



ELECTRIC DRIVES

FOR EVERY DEMAND



Low voltage electrical machines

IEC motors with squirrel-cage rotor
for mains and converter-fed operation

IEC motors with slip-ring rotor

Branch-specific versions

Asynchronous generators

Permanent-magnet synchronous motors



www.vem-group.com

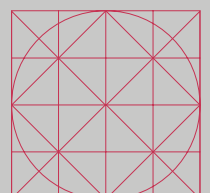



ELECTRIC DRIVES

FOR EVERY DEMAND



Steel and rolling mills



Chemical, oil and gas industry



Power plant technology



Renewable energy



Water management



Shipbuilding



Transportation



Cement and mining industry



Machine and plant engineering



ELECTRIC DRIVES

FOR EVERY DEMAND

There's a saying that less is more. But that is certainly not true in our case. On the contrary. Even the briefest glance into the VEM Catalogue 2017 shows that the product portfolio of the VEM Group has never been broader than it is today. And that is naturally reflected in the impressive scope of the catalogue in front of you. We have structured and modularised the whole VEM product range, and have in this way realised the scalability and adaptability necessary to handle a full spectrum of present and future applications. That refers not only to our drive solutions for outputs ranging from 0.06 kW to 42 MW, but also to variable speed electric drive systems with high energy efficiency ratings, as well as diverse special motors and machines. The expansion of our product range is guided above all by the wishes expressed by customers, and we do everything possible to respond in advance to developments which are only just becoming apparent on the horizon. How do we manage that? There are several explanations. Firstly, we accept no compromises regarding the quality of our work. Our production locations are at the same characterised by a high vertical range of

manufacture, which permits us to react to even unusual customer requests. Close partnerships and valuable exchanges are also cultivated with scientific institutions, colleges and universities.

And last but not least: We possess more than 130 years of experience in electrical engineering. Around 30 million electric machines bearing the VEM badge are currently in use all over the world. They are found aboard ships, in trains and trams, and in chemical plants and rolling mills. VEM generators produce electricity in hydropower plants and wind farms.

The essential message we would like to convey: We are firmly committed to innovation, and already for that reason open to all ideas and suggestions from our customers. You are free to view this catalogue also as orientation for what the future holds in store. We definitely look forward to discussing current and coming developments with you.

Your VEM team

Low voltage electrical machines

Main catalogue 2017

(invalid: Main catalogue 01-2012)

Contents

Introduction	1
Standard motors	2
Transnorm motors	3
Motors for converter-fed operation	4
Water-cooled motors	5
Slip-ring motors	6
Built-in motors	7
Fire-gas motors	8
Roller table motors	9
Explosion-protected motors	10
Motors for operation on ships	11
Permanent magnet synchronous motors	12
Asynchronous generators	13
Built-on components	14
Spare parts	15
Annex	16



Low voltage electrical machines

Contents

Introduction _____	1/2	Motor torque _____	1/20
Information on applicable standards and regulations _____	1/3	Ambient temperature _____	1/20
Technical explanations _____	1/8	Installation altitude _____	1/20
Standards and regulations _____	1/8	Overload capacity _____	1/21
Type designation _____	1/9	Rated efficiency and power factor _____	1/21
Rating plate _____	1/12	Restarting with residual field and phase opposition _____	1/21
Design versions _____	1/12	Motor protection _____	1/21
Cooling and ventilation _____	1/13	Duty cycles _____	1/21
Degree of protection _____	1/13	Paint finish _____	1/25
Vibration response and balancing _____	1/14	Modular construction of different series and modifications _____	1/28
Types of construction _____	1/15	Maintenance _____	1/29
Bearings/bearing lubrication _____	1/16	Inspections _____	1/29
Use of cylindrical roller bearings _____	1/16	Long-term storage (over 12 months) _____	1/29
Loading of bearings and shaft end _____	1/16	Disposal _____	1/30
Bearing monitoring _____	1/17	Fits _____	1/30
Use of insulated bearings _____	1/17	Tolerances _____	1/30
Shaft ends _____	1/18	Noise values, Sound pressure level _____	1/32
True running of the shaft ends _____	1/18	Explanations of modifications _____	1/36
Noise ratings _____	1/18	Overview of modifications _____	1/46
Winding and insulation _____	1/18		
Rated voltage and frequency _____	1/19		
Rated output _____	1/20		

Introduction

Electric machines from VEM are appreciated by millions of users worldwide, and the name VEM is respected as a seal of quality. Large and special machines, as well as standard motors and special drives, are operating reliably in all branches of industry. Plants of all kinds are equipped with motors, generators and drive solutions for the full range of voltages. These products have been demonstrating their strengths for decades, even when exposed to some of the most extreme operating conditions – whether the dust and heat of a rolling mill, explosive atmospheres in the chemical industry, or damp, salt-laden air on the deck of a ship. VEM products comply with all applicable standards and regulations.

Our quality management system is certified and monitored in accordance with ISO 9001:2008 by DNV GL Business

From standard motors to special drives – in use the world over

When you choose our quality products, you can be sure that all challenging aspects such as energy savings and environmentally aware manufacturing have been taken into account. In other words, we supply cost-optimised drive

Assurance, Essen, as well as by IBExU Institut für Sicherheitstechnik GmbH, *Notified Body no. 0637*, as per Article 10(1) of Directive 94/9/EC (new: Directive 2014/34/EU).

The expertise accumulated by our calculation and design departments enables us to tailor our machines to the individual needs of the user. Our designers also work closely with partners from science and research. This cooperation yields products which represent the latest state of the art on the market and thus define the yardstick for coming product generations. At the same time, our companies look back over more than a hundred years of tradition and experience in the manufacturing of electric machines. We supplied hydro-power generators for the first pumped-storage power plants in Germany, for example, and also developed the world's first standard motor series.

Fast and flexible – more than just standard products

With a broad spectrum of low-voltage electric machines, VEM offers versatile, efficient and modular products and system solutions for every branch. In project business, in particular, we supply machines meeting the highest engineering standards to users all over the world.

Our products are characterised by extraordinary reliability, a long service life, effectiveness and environment-friendly operation based on the highest levels of motor efficiency. Extensive modification options promote the universal applicability of VEM drives and permit use in an ever wider range of situations, whether in metallurgy, the chemical

solutions for all individual industrial applications. Our flexibility, the availability of our products and our high delivery reliability support you in your worldwide investment projects.

industry or conveying and transportation systems. Modern manufacturing and comprehensive know-how guarantee fast and reliable deliveries of high-quality drives. Our product range embraces standard and special motors, modern three-phase drives with integrated frequency converter, roller table motors, brake motors, three-phase motors for marine applications, explosion-protected motors, fire gas motors, energy-saving motors, built-in motors, permanent magnet synchronous motors and generators for outputs up to 710 kW.

Industry-wide drive solutions made by VEM – innovative performance for your worldwide installations

Whether as fan or conveyor drives, variable-speed drives for pumps, drive solutions in power generation or compressor drives with outputs of several megawatts, our drives offer convincing product and service quality. Under the trademark VEM, we supply German brand-name products which have earned themselves a considerable share of the worldwide market.

Electric drives are today used throughout industry in the most diverse variants. With their specific properties, they determine the efficiency of countless production processes. The VEM range of three-phase asynchronous motors for low voltages satisfies all customer demands relating to application versatility, improved operating data, environmental compatibility and maximum operating reliability. To this end, VEM motors promise:

- high motor efficiency as the basis for energy-efficient performance
- versions with efficiency classifications IE2, IE3 and IE4 in accordance with IEC/EN 60034-30-1
- universal applications and reduced stock levels thanks to

- IP 55 protection as standard (higher degree of protection up to IP 66 upon request)
- options for terminal box arrangements on the left, top or right
- enhanced service life, reliability and thermal overload capacity to thermal class 155 (F) with thermal reserves as standard (thermal class 180 (H) available as a special version)
- environment-friendly operation based on a low-noise ventilation system
- compliance with East European standards
- free choice between a classic IEC/DIN series and a progressive series based on the mounting dimensions and motor sizes of IEC 60072 (motors without IE classification only)
- facility to incorporate components such as encoders, tachogenerators, brakes, speed monitors or forced ventilation units to solve the customer's individual control tasks

Committed to the environment

Protection and preservation of the environment for the present and all future generations – VEM is fully committed to this responsibility. Together with plant manufacturers, we have been working for many years to promote the use of energy-optimised motors and drive systems, and to maximise energy savings.

Already through its endorsement of the Voluntary Agreement signed between CEMEP and the European Union, as well as support for the EU “Motor Challenge Programme”, VEM documented its clear position with regard to the energy efficiency of its products. This process has been continued purposefully with implementation of Council Directive 2009/125/EC “establishing a framework for the setting of ecodesign requirements for energy-related products”, and is clearly exemplified in conversion of the product range to electric machines with efficiency classifications IE2, IE3 and IE4.

Energy-saving motors from VEM fit into practically every drive concept and are characterised by their significantly

reduced power losses compared to previous standard motors. For many types of the new IE3 series W41R, it has also been possible to pack this increased efficiency into a much smaller housing by using die-cast copper rotors.

Assuming at least 8 hours of operation, energy-saving motors of the efficiency classes IE2, IE3 and IE4 recoup their investment in less than a year. In addition to the specifications contained in standards regarding energy parameters, material-related issues are similarly taken into account, meaning that all critical and proscribed substances (REACH regulations) have been banished from further developments of our motor series. It is a fundamental goal to minimise environmental impacts and to spare natural resources in all phases of the product life cycle.

Sustainability is more than just a buzzword for VEM – it is an inherent component of our corporate philosophy. To achieve more transparent accountability for the environmental policies at the individual locations, the VEM companies are certified to DIN EN ISO 14001 and ISO 50001.

Partners for our worldwide customers

Wherever our customers need electric machines, we are at hand as a partner and offer every necessary support at all phases of a project. It is not important whether you are doing business in Europe, the Middle East, Asia or America. As the VEM market share increases also outside Germany, we are expanding our sales network with a combination of

own subsidiary companies and strategic alliances. Already today, our customers can address their questions to competent and experienced local partners all over the world. Alongside VEM subsidiaries in Finland, Austria, Singapore and Russia, we have established a dense network of sales and service contacts with agents and representatives in more than 40 countries.

Information on applicable standards and regulations

IE-Code

Over the past few years, the worldwide developments relating to energy-saving motors have produced a multitude of country-specific regulations, laws and standards, which makes it difficult to properly compare individual products. The new IEC/EN standard 60034-30 is thus intended to establish a global common basis. In Europe, the standard supersedes the previous “Voluntary Agreement of CEMEP”. Its scope has at the same time been extended to cover an output range from 0.75 kW to 375 kW, not only for 2- and 4-pole motors, but now also to 6-pole versions. When IEC/EN 60034-30-1 came into force, it broadened

the scope of applicability yet again. It currently applies across an output range from 0.12 kW to 1000 kW, and now includes 8-pole motors in the classification. Following the convention used to designate degree of protection (IP = International Protection), the efficiency classes are indicated by the letters IE, standing for International Efficiency:

IE1	Standard Efficiency
IE2	High Efficiency
IE3	Premium Efficiency
IE4	Super Premium Efficiency

Efficiency determination

Parallel to the introduction of the new efficiency classes, the standard describing methods for the determination of efficiency has also been amended. In accordance with IEC/EN 60034-2-1, the additional losses are no longer simply assumed to be 0.5 % of the power input, but instead determined in the manner of IEC 112. The losses determined in this way vary with the motor power and lie between 3.5 % (low power) and 0.5 % of the power input. Consequently, the nominal efficiency may be reduced, even though no actual changes have been made to the motors themselves.

The new limit values have been adapted to this method. IEC/EN 60034-2-1 replaced the previously used IEC/EN 60034-2 with effect from November 2010. As a formal conversion of test results to the new measuring method is not possible, the new stipulations are being introduced in stages. IE-classified motors are always assessed according to IEC/EN 60034-2-1. In the case of motors without classification, the efficiency specifications are in part still based on IEC/EN 60034-2 (indicated accordingly in the present catalogue).

Notes on the application of IEC/EN 60034-30-1 and Commission Regulations (EC) No. 640/2009 and (EU) No. 4/2014

With Commission Regulation (EC) No. 640/2009 of 22nd July 2009, which serves to implement European Directive 2005/32/EC, minimum efficiency classes (Minimum

Efficiency Performance Standard, MEPS) are now stipulated on the basis of EN 60034-30:2009 and are to be gradually introduced in the market for certain types of electric motor.

Which motors are covered by VO (EG) 640/2009 + VO (EG) 4/2014?

Single-speed three-phase asynchronous motors with squirrel-cage rotor for 50 Hz and/or 60 Hz which are designed

- with a rated voltage U_N up to 1000 V;
- with a rated output P_N between 0.75 kW and 375 kW;
- with 2, 4 or 6 poles;

- for duty cycles S1 (continuous duty) or S3 (intermittent periodic duty) with a cyclic duration factor of 80 % or more;
- for direct starting on the mains;
- for rated operating conditions in accordance with EN 60034-1, section 6.

Which motors are excluded from IE classification by EN 60034-30-1?

- Motors which are designed specifically for converter-fed operation in accordance with IEC 60034-25;

- Motors which are fully integrated into a machine (e.g. pumps, fans and compressors) and cannot be tested separately.

Which motors are covered by IEC/EN 60034-30-1?

Single-speed three-phase asynchronous motors with squirrel-cage rotor for 50 Hz and/or 60 Hz which are designed

- with a rated output P_N between **0.12 kW and 1000 kW**;
- with a rated voltage U_N between 50 V and 1 kV;
- with 2, 4, 6 or **8** poles
- for continuous operation at rated output, in which case the temperature increase remains within the range of the specified temperature class;
- for installation at altitudes up to 4000 metres above sea level.

- Motors with 10 or more poles, as well as pole-switching motors;
- Motors with mechanical commutators (e.g. DC motors);
- Motors which are fully integrated into a machine (e.g. pumps, fans and compressors) and cannot be tested separately (IC 418)
- Motors with integrated frequency converter (compact drives) where the motor cannot be tested separately from the converter;
- Brake motors where the brake is an integral component of the internal motor construction and cannot be removed or operated on a separate power supply during efficiency testing;
- Motors which are operated while wholly and permanently immersed in a liquid;
- Fire gas motors from a temperature class >400 °C.

Motors with flanges, feet and/or shaft ends whose mechanical dimensions deviate from those specified in IEC 60072-1 are covered by the present standard. The following motors are excluded:

Which motors are not covered by Commission Regulations (EC) No. 640/2009 and (EU) No. 4/2014?

- a) Motors which are designed to be operated wholly immersed in a liquid;
- b) Motors which are fully integrated into a product (e.g. a gearbox, pump, fan or compressor) such that the energy efficiency cannot be determined separately from the product;
- c) Motors which are designed specifically for operation under the following conditions:
 - i) Altitude more than 4000 metres above sea level;

- ii) Ambient temperatures above 60 °C;
- iii) Maximum operating temperatures above 400 °C;
- iv) Ambient temperatures below -30 °C (any motor) or below 0 °C (water-cooled motor);
- v) Coolant temperatures below 0 °C or above 32 °C at the inlet to a product;
- vi) Potentially explosive atmospheres in the sense of Directive 2014/34/EU
- d) Brake motors

Which deadlines apply for the introduction of minimum efficiency classes?

- Stage 1:** Minimum efficiency class IE2 since 16th June 2011
- Stage 2:** Tightening to IE3 [Premium Efficiency] with effect from 1st January 2015 for the output range 7.5 kW to 375 kW. Optional possibility: "IE2 + converter".
- Stage 3:** Extension of output range to between 0.75 kW and 375 kW with effect from 1st January 2017. The optional possibility "IE2 + converter" remains applicable.

of CE marking that the required nominal efficiency is attained and that the rated efficiency specified on the rating plate is observed. The permissible tolerances specified in IEC/EN 60034-1 continue to apply.

The manufacturer guarantees to the customer by way

New requirements for documentation (taken from Reg. (EC) No. 640/2009 + (EU) No. 4/2014)

From 16th June 2011, the information set out in points 1 to 12 is to be displayed visibly:

- a) in the technical documentation of motors;
- b) in the technical documentation of products into which motors are incorporated;
- c) on freely accessible websites of the manufacturers of motors;
- d) on freely accessible websites of the manufacturers of products into which motors are incorporated.

In the technical documentation, the information must be provided in the order as presented in points 1 to 12. It is not imperative to use the exact wording used in the list. The information may also be presented using graphs, diagrams and symbols.

1. Nominal efficiency (η) at 100 %, 75 % and 50 % of the rated load and voltage (U_N);
2. Efficiency level: "IE2" or "IE3";
3. Year of manufacture;
4. Manufacturer's name or trademark, commercial registration number and place of business;
5. Product model number;

6. Number of poles of the motor;
7. Rated power output(s) or range of rated power output [kW];
8. Rated input frequency(-ies) of the motor (Hz);
9. Rated voltage(s) or range of rated voltage [V];
10. Rated speed(s) or range of rated speed [rpm];
11. Information relevant for disassembly, recycling or disposal at the end-of-life of the product
12. Information on the range of operating conditions for which the motor is specifically designed:
 - (i) altitudes above sea level
 - (ii) ambient air temperatures, also for motors with air cooling
 - (iii) water coolant temperature at the inlet to the product
 - (iv) maximum operating temperature
 - (v) potentially explosive atmospheres

Since 16th June 2011, it is no longer permissible to bring non-classified or IE1 standard motors covered by Commission Regulation (EC) No. 640/2009 onto the market in the EU. The tightened stipulations of Commission Regulation (EU) No. 4/2014 apply since 27th July 2014.

Motors for the North American market

For the US and Canadian markets (insofar as motors according to IEC standards are accepted), approval has been obtained for the motor series from UL (Underwriters' Laboratories Inc.), both for the electrical insulation system and for the motor construction. It is possible to supply motors in accordance with the electrical regulations of NEMA MG1 "Motors and Generators".

The previously applicable Energy Independence and Security Act (EISA) was superseded by the Energy Conservation Program: Energy Conservation Standards for Commercial and Industrial Electric Motors on 1st June 2016. The new legislation raises the required minimum efficiency to the next

higher level for numerous motor types, and its scope of applicability has also been extended to include certain motor types which were not yet covered by the EISA regulations. The responsible legislative authority, the DOE, assesses compliance with the regulations and grants approvals for imports to the US market (CC number) from the point of view of energy efficiency. In this sense, the DOE monitors observance of the minimum requirements by the market. Energy-saving motors from VEM have been granted approval under CC number CC301B for the output range from 5 to 200 hp.

Motor type	Characteristic		Required efficiency class
General purpose electric motor, subtype I	1 to 200 hp standard motor	2, 4, 6 or 8 poles, S1, IM B3, IM B35, IM B34, NEMA Design A or B	NEMA Premium Efficiency
General purpose electric motor, subtype II	U series (old housing 1952–1964)		NEMA Premium Efficiency
	Motor with Design C starting characteristics		
	Close-coupled pump motor		
	Motor without feet	IM B5, IM B10, IM B14	
	Motor with vertical shaft and normal thrust	IM V...	
	8-pole motor		
	Motor ≤ 600 V, but not 230 or 460 V	500 V (50 Hz) 275 V Δ/480 V Y (60 Hz) 480 V (60 Hz) 600 V (60 Hz) 440 V (60 Hz)	
General purpose electric motor	Motor with Design B starting characteristics > 200 to 500 hp	2, 4, 6 or 8 poles, S1, IM B3, IM B35, IM B34, NEMA Design A or B 60 Hz, 230 and/or 460 V	NEMA Premium Efficiency
General purpose electric motor	Motor with Design D starting characteristics		No specification
	Converter-fed motor		
	Intermittent/periodic duty	S3, S4, S5, S6, S7, S8, S9	
	Submersible motor		
	Pole-switching motor		
Size 56 according to NEMA, enclosed version			NEMA Premium Efficiency
Customer-specific version			NEMA Premium Efficiency
Motors for fire extinguishing pumps	1 to 200 hp		NEMA Premium Efficiency

Compliance with foreign regulations

North America

It must always be checked whether motors are to be used in the USA or Canada.

UL approval (UL Files E216022, E216143)

The approval applies for the series **A...**, **B...**, **K...**, **S...**, **W...**, **X...**, **Y...** in sizes 56 to 400.

In addition, the motors are designed electrically to comply with NEMA MG1-12.

Motors are marked accordingly on the rating plate

Additional specifications: Design letter and code letter

The UL certification is thus valid for both the US and Canadian markets.



CSA approval

Motors of the series W41R in sizes between 112 and 315 are approved according to the regulations of the "Canadian Standard Association" (CSA), File No. 184534 – 70014954.

The depicted logo is incorporated into the rating plate.

Built-on and built-in components must also be CSA-listed or else manufactured in compliance with the approval. CSA certification is thus valid for both the US and Canadian markets.



Motors of the series W41R also meet the requirements for "Premium efficiency" in accordance with EISA and CSA C390-10. The series is CSA-certified under File No. 184535 – 70014956.

Neither UL, cULus nor CSA approval has been granted for explosion-protected motors.

Additional regulations apply to motors with legally stipulated minimum efficiency ratings.



China, CCC – China Compulsory Certification

China Compulsory Certification (CCC) was introduced as a mandatory certification and identification system in China in 2002. Under this system, small-power motors exported to China are subject to certification up to a certain rated output.

2-pole, synchronous speed 3000 rpm:	≤ 2.2 kW
4-pole, synchronous speed 1500 rpm:	≤ 1.1 kW
6-pole, synchronous speed 1000 rpm:	≤ 0.75 kW
8-pole, synchronous speed 750 rpm:	≤ 0.55 kW

Since 1st August 2003, the Chinese customs authority has treated CCC as a valid guideline for corresponding motor imports into China.



Customs Union – Russia, Belarus, Kazakhstan

In 2010, it was decided to gradually harmonise the system of certification across the Customs Union (Belarus, Kazakhstan, Russia) and to replace the previous GOST system with so-called Technical Regulations (TR/CU) which are valid for all member states of the Customs Union.

Approved products are identified by way of the new EAC mark of conformity.

It is an imperative prerequisite for a foreign manufacturer to nominate an authorised representative (agency, branch office, sales office, importer) within the Customs Union to assume product liability. The manufacturer must then have a registered TR/CU declaration created and signed by this representative. This declaration is registered with the GOST certification office and must also be presented to customs in a simple copy.



For explosion-protected motors, VEM possesses EAC Ex certificate no. **TC/RU C-DE.ГБ08.B.00859**.

This covers the explosion protection types:

Ex nA (series KPR, KPER, (IE.-)K1.R, W.1R, (IE.-)W41R and (IE.-)W42R)

Ex e (series (IE.-)K1.R, (IE.-)K2.Q and W.1R)

Ex tD (series KPR, KPER, (IE.-)K1.R and W.1R)

Ex d/de (series K8.R, B82 and K8UR)

GAZPROM

VEM possesses approval from GAZPROM/Russia for the motor series A, B, C, G, K, S, W and Y. The number of the approval certificate is **ГО00.DE.1339.H00003**.

Spare motors in EFF2, EFF1 and IE1

Deliveries of motors in this design version are definitively no longer possible. This applies also to the Eff1 design version. Use of the EFF mark was only permitted until 15th June 2011. Since this time, the manufacturing of IE1 motors has only been permissible under the exception clauses specified in Commission Regulation (EC) No. 640/2009. Spare parts can still be supplied without restriction.

Optimised IE2 series WE2R

IE2 motors are available for the whole output range from 0.75 to 355 kW. In the meantime, individual sizes have been optimised and offered parallel to the W.1R series under the type designation WE2R. These types use a new, longer housing. The motors of the WE2R series have replaced the corresponding W.1R types since 2013.

Technical explanations

Standards and regulations

The motors comply with all relevant standards and regulations, in particular with the following:

Title	International	Europe
	IEC	EN
Rotating electrical machines. Rating and performance	IEC 60034-1	EN 60034-1
Methods for determining losses and efficiency of rotating electrical machinery from tests	IEC 60034-2-1	EN 60034-2-1
Efficiency classes of single-speed, three-phase, cage-induction motors	IEC 60034-30-1	EN 60034-30-1
Degree of protection provided by the integral design of rotating electrical machines (IP code) – Classification	IEC 60034-5	EN 60034-5
Methods of cooling (IC code)	IEC 60034-6	EN 60034-6
Classification of types of construction, mounting arrangements and terminal box position (IM code)	IEC 60034-7	EN 60034-7
Terminal markings and direction of rotation	IEC 60034-8	EN 60034-8
Noise limits	IEC 60034-9	EN 60034-9
Starting performance of single-speed three-phase cage induction motors	IEC 60034-12	EN 60034-12
Mechanical vibration of certain machines with shaft heights 56 mm and higher – Measurement, evaluation and limits of vibration severity	IEC 60034-14	EN 60034-14
Mechanical vibration. Balance quality requirements for rotors in a constant (rigid) state	ISO 1940	-
IEC standard voltages	IEC 60038	-
Electrical insulation – Thermal evaluation and designation	IEC 60085	-
General purpose three-phase induction motors having standard dimensions and outputs	IEC 60072-1	EN 50347
Explosive atmospheres Part 0: Equipment – General requirements	IEC 60079-0	EN 60079-0
Explosive atmospheres Part 1: Equipment protection by flameproof enclosures “d”	IEC 60079-1	EN 60079-1
Explosive atmospheres Part 7: Equipment protection by increased safety “e” (new „eb“)	IEC 60079-7	EN 60079-7
Explosive atmospheres Part 15: Equipment protection by type of protection “n” (new: Increased safety „ec“, part 7)	IEC 60079-15	EN 60079-15 (EN 60079-7)
Explosive atmospheres Part 31: Equipment dust ignition protection by enclosure “t”	IEC 60079-31	EN 60079-31
Explosive atmospheres Part 10-2: Classification of areas – Explosive dust atmospheres	IEC 60079-10-2	EN 60079-10-2

VEM motors comply furthermore with various foreign regulations which are either based on IEC 60034-1 or else transpose the latter's stipulations as European standard EN 60034-1.

The following temperature-rise limits apply in conjunction with the aforementioned standards and regulations:

Regulation	Cooling air temperature	Permissible temperature-rise limit in K (measured by resistance method)				
		105 [A]	120 [E]	130 [B]	155 [F]	180 [H]
Thermal class acc. to EN 62114	°C					
EN 60034-1	40	60	75	80	105	125
IEC 60034-1	40	60	75	80	105	125
Great Britain	40	60	75	80	105	125
Italy	40	60	70	80	105	125
Sweden	40	60	70	80	105	125
Norway	40	60	-	80	105	125
Belgium	40	60	75	80	105	125
France	40	60	75	80	105	125
Switzerland	40	60	75	80	105	125

Type designation

The type designation comprises 8 basic parts + a code for special versions, namely

- the **energy efficiency class**,
- the **motor version**,
- the **series code**,
- the **type of cooling**,
- the **size/shaft height**,
- the **foot length** and a **supplementary code for output definition**,
- the **number of poles**,
- the code for the **type of protection in case of explosion-protected motors** and
- the **special version code**,

which are strung together to form a complete motor designation. It is not imperative for each of the 8 elements to be present. In the following, the individual elements are explained together with their possible combinations. **Deviations from the type designation are only permissible for certified series, for example CSA-certified motors are only available as K11R (see Point 10 – Series).**

IE2	-	W	E	1	R		160	M	X	2		Ex e IIC T3	IL	...	HW
1		2	3	4			5	6	7			8	9	...	10

1. Energy efficiency class

Designation	Standard
(none) Not classified	-
IE1 Standard Efficiency	IEC/EN 60034-30-1
IE2 High Efficiency	IEC/EN 60034-30-1
IE3 Premium Efficiency	IEC/EN 60034-30-1
IE4 Super Premium Efficiency	IEC/EN 60034-30-1

2. Motor version

Designation	Description
A	Roller table motor
B	Brake motor (squirrel-cage rotor)
G	Asynchronous generator
K	Squirrel-cage rotor
P	Permanent-magnet synchronous motor
S	Slip-ring rotor
W	Energy-saving motor
Y	Squirrel-cage rotor, housing rotated, terminal box on N end
DS	Three-phase transnorm motor as welded steel construction

3. Series

Designation

	Not specified in case of three-phase transnorm motors as welded steel construction
10	Design generation 1, progressive IEC series
11	Design generation 1, IEC/DIN series
12	Design generation 1, IEC/DIN series, deviating basic type assignment
20	Design generation 2, progressive IEC series
21	Design generation 2, IEC/DIN series
22	Design generation 2, transnorm series
23	Design generation 2, transnorm series, increased output
25	Design generation 2, progressive series, DIN shaft height/output assignments
41	Energy-saving series with efficiency class IE3
42	Energy-saving series with efficiency class IE3, transnorm motors with internal cooling
46	Energy-saving series with efficiency class IE3, altered basic type 60 Hz
5	High-voltage version, 2.2 – 6.6 kV
52	High-voltage version, transnorm motors
E1	Energy-saving series with efficiency class IE2, design generation 1
E2	Energy-saving series with efficiency class IE2, design generation 2 (all sizes/numbers of poles)
E6	Energy-saving series with efficiency class IE2, altered basic type 60 Hz
U0	Design generation 2, progr. IEC series, converter-fed operation, curve A, DIN VDE 0530-25:2009
U1	Design generation 2, IEC/DIN series, converter-fed operation, curve A, DIN VDE 0530-25:2009
U2	Design generation 2, transnorm series, converter-fed operation, curve A, DIN VDE 0530-25:2009
V0	Design generation 2, progr. IEC series, converter-fed operation, curve B, DIN VDE 0530-25:2009
V1	Design generation 2, IEC/DIN series, converter-fed operation, curve B, DIN VDE 0530-25:2009
V2	Design generation 2, transnorm series, converter-fed operation, curve B, DIN VDE 0530-25:2009
V4	Design generation 2, DIN series, converter-fed operation, curve B, DIN VDE 0530-25:2009
P	In combination with 2 nd code element S, motors with slip-ring rotor
PE	In combination with 2 nd code element S for slip-ring rotor, DIN motors
RB	In combination with 2 nd code element A: Roller table motor for mains operation, type of cooling IC 410, 4 th code element not applicable
RC	Ring-ribbed housing In combination with 2 nd code element A: Roller table motor for converter-fed operation, type of cooling IC 410, 4 th code element not applicable
RG	Ring-ribbed housing In combination with 2 nd code element A: Geared roller motor for converter-fed operation, type of cooling IC 410

4. Type of cooling

4.1 Standard series

	Designation	Type of cooling
A	Open-circuit air cooling	IC 01, IC 06
B	Water cooling	IC 71W, IC 31W
WM	Water jacket cooling for three-phase transnorm motors as welded steel construction, series DS..	IC 71W, IC 31W
F, f	Rib cooling with built-on forced-ventilation fan	IC 416
O, o	Rib cooling without own fan	IC 410
R	Rib cooling with own fan	IC 411
U	Closed-circuit air cooling	IC 511

4.2 Slip-ring rotor, crane and steelworks versions

	Designation	Type of cooling
E	Rib cooling with built-on forced-ventilation fan	IC 416
H	Rib cooling with own fan	IC 411
T	Rib cooling without own fan	IC 410

5. Size

56, 53, 71, 80, 90, 100, 112, 132, 160, 180, 200, 225, 250, 280, 315, 355, 400
 ARB: 22 (132), 33 (125), 54 (170) und 65 (200)
 Figures in brackets: Shaft height in mm

6. Foot length

Foot length	Designation	Supplementary code	Supplementary code for output definition
S	short	X	Designation Higher output in case of two outputs/foot length
M	medium	Y	Reduced output*)
L	long	Z	Higher output in case of three outputs/foot length *) increased output for size 315

7. Number of poles

2p= Synchronous speed n (at 50 Hz) [rpm]

2	3000
4	1500
6	1000
8	750
10	600
12	500
16	375
20	300
24	250

Hyphen as separator in case of pole-switching motors, descending number of poles

8. Codes for special design versions

8.1 Codes for type of protection for explosion-protected equipment (always specified immediately after the number of poles!)

Code	Type of protection
Ex e IIC T1/T2, T3 or T4	Increased safety "e"
Ex eb IIC T1/T2, T3 oder T4	Increased safety "eb" acc. to EN 60079-7:2015
Ex nA IIC T1/T2, T3 or T4	Non sparking "n" to EN 60079-15:2010
Ex ec IIC T1/T2, T3 oder T4	Increased safety "ec" acc. to EN 60079-7:2015
Ex II 2D	Protection by enclosure "tb"
Ex II 3D	Protection by enclosure "tc"
Ex eb IIC T. 2D	Increased safety "eb" or protection by enclosure "tb"
Ex eb IIC T. 3D	Increased safety "eb" or protection by enclosure "tc"
Ex ec IIC T. 2D	"ec" or protection by enclosure "tb"
Ex ec IIC T. 3D	"ec" or protection by enclosure "tc"
Ex d(e) IIC (B) T4, T5 or T6	Flameproof enclosure "d" or "de"

8.2 Efficiency class for certified design versions which exclude marking by way of code element 1

Marking in accordance with the table under Point 1 as a suffix

8.3 Fire gas class

VEM category	Class acc. to DIN EN 12101-3	Operating time/stress temperature in case of emergency
FV (formerly FV0)	F _{f200} (60)	1 hour at 200 °C
FV1	F ₂₀₀	2 hours at 200 °C
FV2, FV2-1	F _{f250} (60)	1 hour at 250 °C
	F ₃₀₀	1 hour at 300 °C
FV3, FV3-1	F _{f250}	2 hours at 250 °C
	F ₃₀₀	2 hours at 300 °C
FV4-2, FV4-4	F ₄₀₀	2 hours at 400 °C
	F _{f400} (90)	1,5 hours at 400 °C
	F _{f400} (60)	1 hour at 400 °C
FV4-3	F ₄₀₀	2 hours at 400 °C
FV5	F ₆₀₀	1 hour at 600 °C

9. Codes for special versions

TWH	Thermal winding protection with NTC thermistor
TPM	Thermal winding protection with PTC thermistor
WE	Special shaft
....

For further special versions, see overview of modifications

Rating plate

In the normal standard version, the motor rating plate displays information in the German and English languages. Other languages are possible, though an extra charge must be made for non-EU languages.

The rating plate displays the most important rating data, such as the type designation and motor number, output, rated voltage and frequency, rated current, type of construction, type of protection, power factor, speed, thermal class, IE code with efficiency rating, and explosion protection type.

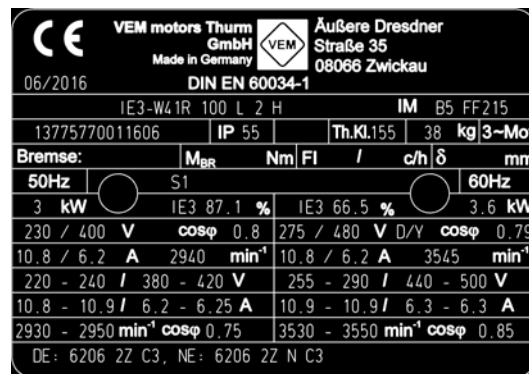
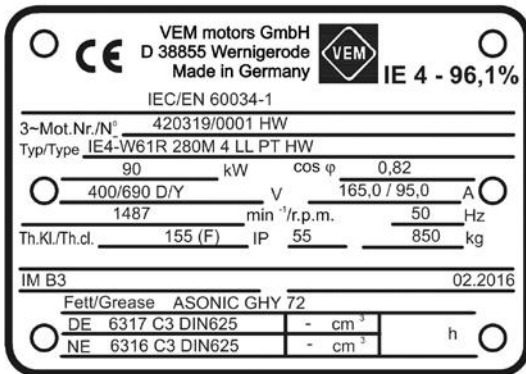

Design versions

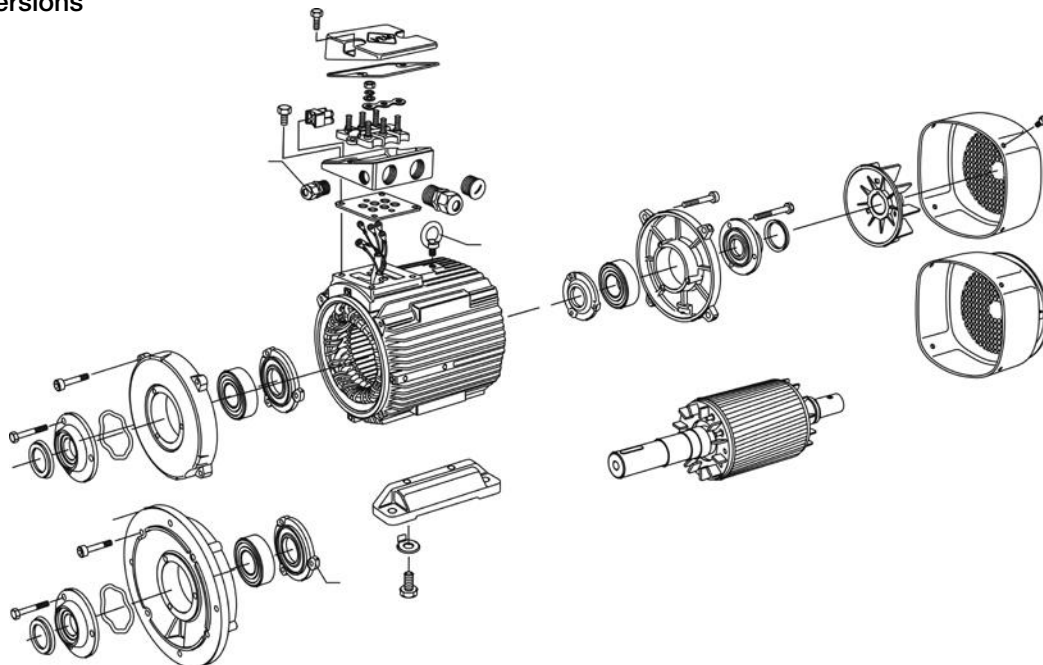

Motors comprise the following main components:

- Stator housing with laminated core and winding
- End shields with bearings
- Die-cast rotor (aluminium or copper)
- Fan with fan cowl
- Terminal box

The motor space is defined by the housing, the two end shields, the outer bearing cover, the shaft seal and the

The scope of information may vary according to motor type. In the case of motors with relubrication system, the relubrication interval and the grease amount per lubrication cycle are also specified either on the rating plate itself or on an additional plate. Rating plates are attached to the housing using grooved pins such that they are permanently secure. They can be made of aluminium or stainless steel (extra charge). Consultation is necessary if additional plates are required.

terminal box gasket. Stator housings are always manufactured in grey cast iron, with radially or horizontally/vertically arranged cooling ribs. A flange surface with a corresponding opening to the housing inner is cast-on for mounting of the terminal box and terminal base. The flange surface is covered by the terminal box gasket. The terminal box can be arranged on the right, on the left or on the top.

In the case of heavy-duty roller table motors, ring-ribbed housings are used.

Shaft height	Series	Material for housing end shields feet	Foot mounting	
63 to 132 T	KPER, K21R, W.2R	Grey cast iron	Bolted	
100 LX	KPER, K21R, W.2R		Cast-on	
132 to 280	K11R, K21R, W.1R, W.2R		Bolted	
315	K11R, K21R, W.1R, W.2R, PE.R		Cast-on	
355, 400	K22R, W22R, WE1R, WE2R, W41R, W42R		Cast-on	
56 to 100	KPR, K20R		Cast-on	
112 to 250	K10R, K20R		Bolted	
280 to 315	K10R, K20R		Cast-on	
225 to 280	K21B, K23B		Grey cast iron	Bolted
315 to 400	WE1B, W21B, W4.R		Sheet steel	Welded
132 to 200	ARB	Grey cast iron	Cast-on	
112 to 400	ARC		Cast-on	
355 to 630	DS, DSf, DSo, DSWM	Sheet steel	Welded	
132 to 250 M	SPER, SPEH	Grey cast iron	Bolted	
250 MX to 315	S11R, S11H		Cast-on	
132 to 225	SPR, SPH		Bolted	
250 to 280	S10R, S10H		Cast-on	

Cooling and ventilation

The motors are fitted with radial fans made from plastic or cast aluminium alloy, which provide cooling independently of the running direction of the motor (IC 411 to IEC/EN 60034-6). For noise reasons, 2-pole motors with shaft height 355/400 can only be supplied with low-noise, direction-dependent fans. If requested by the customer, 2-pole motors with

smaller shaft heights can also be fitted with a low-noise, direction-dependent fan. When installing the motors, a minimum clearance between the fan cowl and the wall (dimension BI) must be observed to ensure correct cooling. The fan cowl is always manufactured in sheet steel.

Degree of protection

Overview of possible degrees of protection in accordance with IEC/EN 60034-5, EN 60529:

Against penetration of foreign objects	Not protected	≥ 1,0 mm	Dust-proof	Dust-tight
Against contact with hazardous parts	Not protected	Wire	Wire	
	1 st numeral → 0	4	5	6
Against harmful ingress of water	2 nd numeral			
Not protected	0	IP 00		
Splashed water	4	IP 44	IP 54	
Water jets	5		IP 55	IP 65
Powerful water jets	6		IP 56	IP 66
Temporary immersion	7		IP 57S ¹⁾	IP 67

¹⁾ S ... Standstill

The motors possess condensate drain holes in the end shields (by request only for shaft heights up to 132 T); these holes are closed with plastic plugs.

In case of motors with a shaft end pointing upwards, the user must take appropriate precautions to prevent the penetration of water along the shaft.

On flange motors of construction types IM V3 / IM V36 , a drain hole is provided as standard to prevent the collecting of liquid in the flange end. Where motors are to be used or stored outdoors, a corresponding roof or additional covers are recommended in order to avoid long-term exposure to direct sunlight, rain, snow and dust, and to eliminate the risk of the fan freezing up due to direct snowfall or icing. In such cases, it is recommended to consult the manufacturer for technical clarification.

Vibration response and balancing

The permissible vibration severities for electric motors are specified in standard IEC/EN 60034-14. VEM motors already meet or remain below the limit values specified for vibration severity grade A (normal, without designation on

The machines are suitable for use in tropical environments. Guide value of 60 % relative humidity at coolant temperature 40 °C
Ambient temperature: -20 °C to +40 °C
Installation altitude: ≤ 1000 metres above sea level

The use of non-rusting bolts and screws (option) is recommended if the motor is to be used outdoors or in a corrosive environment. Any deviating ambient conditions are specified on the motor rating plate.
The specifications on the rating plate shall then apply.

the rating plate) in their basic versions. Vibration severity grade B (special code “SGB” in the type designation) can be supplied at extra charge.
IEC/EN 60034-14 recommends the following values:

Vibration severity grade	Shaft height H	56 ≤ H ≤ 132			132 ≤ H ≤ 280			280 > H		
		S _{eff} [µm]	V _{eff} [mms ⁻¹]	a _{eff} [ms ²]	S _{eff} [µm]	V _{eff} [mms ⁻¹]	a _{eff} [ms ²]	S _{eff} [µm]	V _{eff} [mms ⁻¹]	a _{eff} [ms ²]
A	Free suspension	25	1,6	2,5	35	2,2	3,5	45	2,8	4,4
	Rigid mounting	21	1,3	2,0	29	1,8	2,8	37	2,3	3,6
B	Free suspension	11	0,7	1,1	18	1,1	1,7	29	1,8	2,8
	Rigid mounting	-	-	-	14	0,9	1,4	24	1,5	2,4

Grade A is applicable for machines with no special vibration requirements.

This grade is essentially equivalent to the old grade N in case of free suspension. For motors from size 250, the limit values are tightened from 3.5 mm/s to 2.8 mm/s. This corresponds to the former limit value for R at speeds > 1800 rpm.

Grade B is applicable for machines with special vibration requirements.

This grade is essentially equivalent to the old grade S in case of free suspension.

The corner frequencies for vibration displacement/vibration velocity and vibration velocity/vibration acceleration are 10 Hz and 250 Hz, respectively. It must be noted that the measured values may deviate from the actual values by ±10 % due to the tolerances of the measuring devices.

With regard to the routine testing of machines with speeds between 600 and 3600 rpm, IEC/EN 60034-14 states that it is sufficient to measure the vibration velocity.

All rotors are balanced dynamically with a half-key in place. This balancing is documented on the rating plate by way of the letter “H” after the motor number. Upon request, it is possible to perform balancing with a full key. This is subsequently indicated by the letter “F” after the motor number.

In case of converter-fed operation with frequencies greater than 60 Hz, special balancing is required to observe the specified limit values (high-speed version, special code “HS” in the type designation).

Types of construction

The most common types of construction are shown in the table below. Further types of construction can be supplied upon request. The type of construction is indicated on the rating plate in accordance with Code I, IEC/EN 60034-7. Standard motors which are ordered in a basic type in sizes 56 to 200 can also be operated with the following derived types of construction:



IM B3 in IM B5, IM B7, IM B8 and IM V6
 IM B35 in IM 2051, IM 2061, IM 2071 and IM V36
 IM B34 in IM 2151, IM 2161, IM 2171 and IM 2131
 IM B5 in IM V3
 IM B14 in IM V19

Motors of types IM V5, IM V1 or IM V18 can be designed with an optional protective canopy to prevent small parts falling into the motor. In accordance with the regulations,

explosion-protected motors of these types are either provided with a protective canopy as standard, or else the user must make provisions to prevent small parts falling into the motor. With types of construction with the shaft end pointing upwards, it is the responsibility of the user to provide a suitable cover to prevent small parts falling into the fan cowl (see also standard IEC/EN 60079-0).

The cooling air flow must not be hindered by the cover. From size 225, it is necessary to consult the manufacturer regarding types of construction IM V5, IM V6, IM B6, IM B7 and IM B8. The types of construction IM B5 and IM V3 are not available for frame sizes from 315 L.

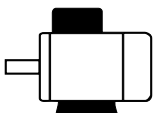
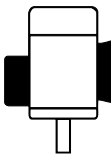
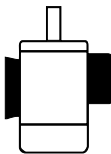
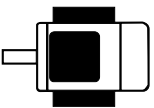
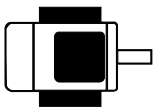
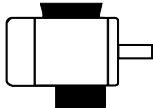
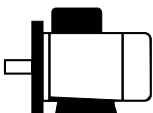
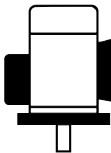
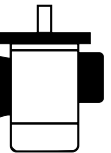
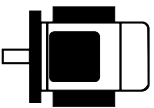
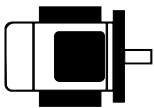
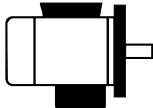
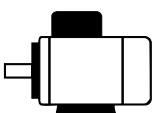
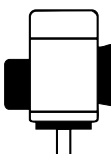
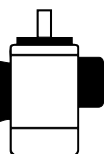
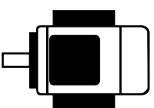
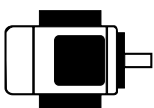
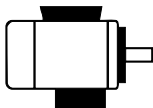
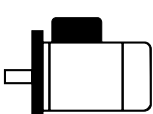
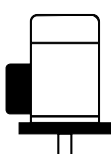
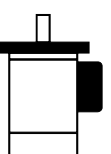
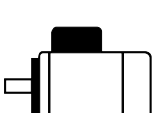
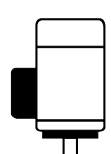
To facilitate connection to the mains power supply, the terminal box can be rotated by 90° with all types of construction (with the exception of motors with an inclined terminal box 630 or 1000, where the terminal box can only be rotated by 180°).

Basic type of construction	Derived types of construction				
IM B3 IM 1001 	IM V5 IM 1011 	IM V6 IM 1031 	IM B6 IM 1051 	IM B7 IM 1061 	IM B8 IM 1071 
IM B35 IM 2001 	IM V15 IM 2011 	IM V36 IM 2031 	– IM 2051 	– IM 2061 	– IM 2071 
IM B34 IM 2101 	– IM 2111 	– IM 2131 	– IM 2151 	– IM 2161 	– IM 2171 
IM B5 IM 3001 	IM V1 IM 3011 	IM V3 IM 3031 			
IM B14 IM 3601 	IM V18 IM 3611 	IM V19 IM 3631 			

Bearings/bearing lubrication

VEM motors are fitted with anti-friction bearings from leading manufacturers. The nominal service lifetime of the bearings is at least 10,000 hours for 2-pole motors or 20,000 hours for motors with 4 or more poles, assuming full exploitation of the maximum permissible load. The nominal service lifetime of the bearings for motors installed in a horizontal position without additional axial load is 40,000 hours in coupled operation.

Under average operating conditions, with loads below the maximum permissible load, a nominal service life Lh10 of 10,000 hours can be achieved.

The design versions

- fixed bearing at N-end,
- without fixed bearing (floating bearing arrangement),
- permanent lubrication,
- relubrication device,
- heavy-duty bearing at D-end (for increased lateral forces),
- light-duty bearings,

as well as

- anti-friction bearing assignments
- disc and wave spring assignments
- V-ring assignments and
- illustrations of the bearing arrangements

can be taken from the bearing overviews. The corresponding flat grease nipples are specified in the tables of the design drawings. The bearings of motors in normal versions with two deep-groove ball bearings are preloaded by way of disc or wave springs. Exceptions to this rule are versions with cylindrical roller bearings at the D-end (heavy-duty bearing arrangement VL). The arrangement “fixed bearing at N-end” is available as an option for motors of the type “without fixed bearing”. Fixed bearings at the D-end are possible upon request.

The most important prerequisite for achievement of the nominal bearing lifetime is correct lubrication, i.e. use of the correct type of grease for the given application, filling with the correct amount of grease, and observance of the relubrication intervals.

The bearings of motors in sizes 56 to 160 are provided with lifetime lubrication. These bearings must be replaced in good time in accordance with maximum service life of the grease. For motors from size 180, the bearings must be relubricated in good time in accordance with maximum service life of the grease.

Under normal loads and operating conditions, a motor can be operated for approximately 10,000 hours in the case of 2-pole versions or approximately 20,000 hours in the case of versions with more than 2 poles before the grease in the anti-friction bearings must be replaced, unless agreed otherwise. The condition of the grease should nevertheless be checked from time to time already before this threshold is reached. In the case of permanently lubricated bearings, replacement of the bearing or grease should be planned at the latest after 4 years due to the gradually reduced lubricating properties of the grease over time. The specified numbers of operating hours apply only for operation at rated speed.

In case of converter-fed operation, the specified lubrication intervals must be reduced by approximately 25 % on account of the increased motor temperatures. If the nominal speed is exceeded in converter-fed operation, the relubrication interval is shortened approximately in inverse proportion to the increase in speed.

The bearing must be cleaned thoroughly using a suitable solvent before refilling with new grease. The same type of grease must be used. If the original type is not available, only the equivalent types specified by the motor manufacturer may be used as alternatives. It is important that the space in the bearing is only filled to approximately two-thirds of its capacity. Complete filling of the bearing and bearing cover with grease will lead to increased bearing temperatures and consequently increased wear.

Bearings fitted with a relubrication device are relubricated via the grease nipple while the motor is running. The appropriate amount of grease is specified for the particular motor. The relubrication intervals can be taken from the following table.

IEC/DIN series	Size	2-pole version	4-pole version or greater
	Transnorm series		
132 to 280	100 to 250	2000 h	4000 h
315	280 to 315	2000 h	4000 h
355, 400	-	2000 h	3000 h

Use of cylindrical roller bearings

Relatively large radial forces or masses can be taken up at the end of the motor shaft where cylindrical roller bearings are used (“heavy-duty bearing arrangement” VL). Examples: Belt drives, pinions or heavy couplings. The minimum radial force at the shaft end must be a quarter of the permissible radial force. The permissible shaft end load is to be taken into account. The relevant specifications can be taken from the selection data tables and diagrams.

Important note:

If the radial force falls below the minimum value, damage to the bearings may result already within a few hours. Test runs without load are only permissible for short periods.

If the specified minimum radial force is not reached, we recommend the use of deep-groove ball bearings (“light-duty bearing arrangement” LL). The bearings can be changed upon request.

Loading of bearings and shaft end

The international standardisation of asynchronous motors means that the dimensioning of bearings and shafts can

only be varied within certain limits. Consequently, an optimum design size has been selected.

Permissible shaft end loading

The permissible shaft end loading is determined by the following main criteria:

- Permissible bending of the shaft
- Shaft end fatigue strength
- Bearing lifetime

The following load diagram applies:

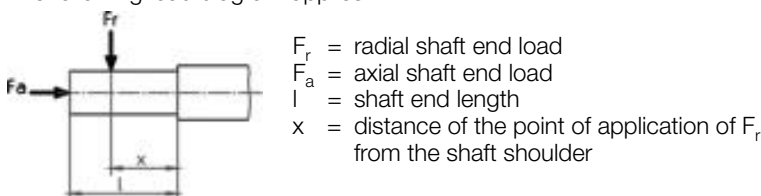

Type-specific values for the permissible axial shaft end load F_a and the permissible radial shaft end load $F_{r0.5}$ (at point of application $x : l = 0.5$), $F_{r1.0}$ (at point of application $x : l = 1.0$) for the basic version and for the heavy-duty bearing arrangement with horizontal and vertical mounting of the motor are given in the tables in Chapter 2. The permissible axial shaft loads for sizes 315 L, 315 LX, 355 and 400 are available upon request. The permissible radial loads for motors mounted in horizontal and vertical positions are specified as dependent on the position of the point of application on the shaft end (taking into account the direction of the radial force in relation to gravity). The permissible loads given refer to installation of the motor practically free of vibration and load application planes as specified above. Verification of the shaft loading for size 355 can be provided by the manufacturer upon request. In general, the loads F_r and F_a are dependent on the transmission members used, i.e. on the axial and radial forces occurring at these transmission members, as well as their masses.

The forces are calculated in accordance with mechanical equations, e.g. for drive belt pulleys

$$F_r = 2 \cdot 10^7 \cdot \frac{P}{n \cdot D} \quad \text{where}$$

Bearing monitoring

To permit monitoring of the condition of the bearings, motors can be fitted with or prepared for the fitting of temperature, shock pulse and vibration sensors. PT100-type temperature sensors can be mounted at the bearing points in 2-, 3- or 4-wire configurations. The sensors are connected at the main terminal box or else in a separate box mounted either on the main terminal box or on the motor housing,

Use of insulated bearings

When motors are operated on the mains, magnetic asymmetries result in a voltage along the shaft. This shaft voltage causes compensating currents to flow between the rotor and stator via the anti-friction bearings. If the voltage exceeds a threshold of 500 mV, the bearings may be damaged. The design of VEM standard motors ensures that this value can never be exceeded.

Such effects may be intensified in case of converter-fed

The permissible shaft end load (radial and axial forces) is based on a nominal bearing lifetime of 20,000 hours and a safety factor of > 2.0 regarding fatigue failure.

- F_r = Radial force in N
 P = Nominal output of the motor in kW (transmission power)
 n = Nominal speed of the motor
 D = Belt pulley diameter in mm
 c = Pretensioning factor as specified by the belt manufacturer (for V-belts normally 2.5)

In practice, the radial force F_r is not always effective at $x : l = 0.5$. The permissible radial force can be calculated by way of linear interpolation over the range from $x : l = 0.5$ to $x : l = 1.0$.

If the calculated shaft loads are greater than the permissible load, it is necessary to modify the drive elements. Possible modifications include:

- Selection of a larger belt pulley diameter
- Use of V-belts instead of flat belts
- Selection of a different pinion diameter or bevel angle
- Selection of a different coupling version, etc.

In general, it should be ensured that the resulting point of application of force F_r does not lie beyond the shaft end as far as possible. If no solution can be found, the manufacturer would be glad to investigate special constructions with which problems of this kind can be handled.

depending on the individual design. For monitoring of the wear of the anti-friction bearings, shock pulse sensors [SPM] can be mounted on the end shields from size 132. This permits monitoring by way of mobile recording units. It is also possible to use hard-wired shock pulse or vibration sensors to enable remote monitoring.

operation. The converter design is a decisive influencing factor. Pulse-controlled converters produce especially high-frequency voltages and currents dependent on the pulse frequency and the pulse modulation. Output filters in the converter minimise these effects. To avoid bearing damage, motors for converter-fed operation from size 315 MY are always fitted with an insulated bearing on the non-drive end.

In addition to this measure, it is always imperative to provide for proper earthing of the motor housing in order to drain the currents circulating between the converter and stator.

Shaft ends

IEC 60034-7 defines the two sides of a motor as follows:

D-end (DS): Drive side of the motor (drive side)
 N-end (NS): Side of the motor opposite the drive (non-drive side)

Centre holes in accordance with DIN 332, sheets 1 and 2, form DS.

The keys and keyways are machined in accordance with DIN 6885 sheet 1, form A or B for frame sizes 56–112 and in accordance with DIN 6885 sheet 1, form A for frame sizes 132–355. The lengths of the keys comply with EN 50347 for shaft heights 132–355.

Threads for fitting and pulling fixtures

Shaft end diameter	Thread
from 7 to 10 mm	M3
from 10 to 13 mm	M4
from 13 to 16 mm	M5
from 16 to 21 mm	M6
from 21 to 24 mm	M8
from 24 to 30 mm	M10
from 30 to 38 mm	M12
from 38 to 50 mm	M16
from 50 to 85 mm	M20
from 85 to 130 mm	M24

True running of the shaft ends

The true running of the shaft ends complies with the requirements of EN 50347. The relevant values can be reduced

Noise ratings

Noise levels are measured at rated output, rated voltage and rated frequency in accordance with EN ISO 3741. IEC/EN 60034-9 stipulates that the noise level in dB(A) is to be specified as the spatial mean value of the sound pressure level L_{pA} measured at a distance of 1 metre from the machine contour.

The A-weighted sound power level L_{WA} over the measuring surface L_S ($d = 1$ m) is calculated with

$$L_{WA} = L_{pA} + L_S \quad (\text{dB})$$

Winding and insulation

VEM motors of the series W.../K2.../S.../P.../A... are designed for thermal class 155 [F] as standard. High-quality enamelled wires and insulating sheet materials are used in conjunction with low-solvent resin impregnation. The standard insulation system accommodates rated voltages up to 725 V [mains feed]. It guarantees high mechanical and electrical strength, and provides for a long service life.

Motors are available in three versions:

For converter-fed operation without filter up to 420 V converter output voltage
 For converter-fed operation without filter up to 500 V converter output voltage, curve A to DIN VDE 0530-25:2009
 For converter-fed operation without filter up to 690 V converter output voltage, curve B to DIN VDE 0530-25:2009

The motors are always supplied with the shaft key inserted.

The second shaft is able to transmit the full nominal output in the case of a coupled drive. The output transmitted by the second shaft end in the case of belt, chain and pinion drives can be notified upon request. Slotted drive elements, such as belt pulleys or couplings, must be balanced with a half-key to at least balance quality grade G 6.3 according to DIN ISO 1940-1.

The measuring surface level is dependent on the machine geometry and is for

Frame size	L_S (dB)
56 – 132	12
160 – 225	13
250 – 315	14
355	15

The noise values for the main series are presented in tabular form. For machines in 60 Hz versions, a value 4 dB(A) higher than the table value can be taken as a guideline. Binding specifications for 60 Hz upon request. Consultation is necessary with regard to special series.

According to VIK recommendation 04.2011, point 6.7 / NAMUR recommendation NE38, motors may be subjected to a maximum peak voltage of 1350 V in accordance with DIN IEC/TS 60034-17, figure 6, and a rate of voltage rise du/dt of 1.5 kV/ μ s at the motor terminals. Higher peak voltages must be agreed.

Accordingly, converter-fed VIK motors from size 132 [except 132 T] to 400 are designed as K2.R/W..R/PE.R motors unless other peak voltages are agreed separately.

Rated voltage and frequency

In their basic versions, motors are supplied for the following rated voltages and frequencies:

230/400 V Δ/Y , 50 Hz
 400/690 V Δ/Y , 50 Hz
 500 V, 50 Hz

275/480 V Δ/Y , 60 Hz
 600 V, 60 Hz

The motors can be operated without modification of the rated output on mains systems where the voltage at rated frequency deviates by up to +5 % from the nominal value (rated voltage range A). At rated voltage, the frequency in these mains systems may deviate by ± 2 % from the nominal value. The aforementioned standard voltages to DIN IEC 60038 are taken to define the design point. Special voltages and frequencies are possible by customer request.

Motors of the series K21./K20. which are to be suitable for a mains voltage to DIN IEC 60038 with an overall tolerance of ± 10 % are selected according to the corresponding rated voltage as listed in the technical tables. The rated voltage range limited by U_U and U_O is similarly specified there.

An additional tolerance of ± 5 % applies at these voltage limits. In accordance with IEC/EN 60034-1, it is permissible for the temperature to exceed the limit values for the corresponding thermal class by up to 10 K during operation at the voltage limits.

For motors of sizes 56 to 112 (DIN)/56 to 100 (progressive series), the current for the upper voltage range U_O is set such that, given normal setting of the motor circuit-breaker to $1.05 \times I_n$, the breaker will also not be tripped in no-load operation and at ± 5 % tolerance.

Motors with IE classifications can also be supplied for an extended voltage range. In this case, the preferred form of marking is to specify the corresponding range in accordance with IEC/EN 60034-1.

When the rated voltage is indicated alongside the specification of

Zone A or B

in accordance with IEC/EN 60034-1, it is only necessary to specify the efficiency class (IE code) and the efficiency rating at this voltage, e. g.

400/690 V (Zone B) Δ/Y .

Voltage selection according to VIK Recommendation 1, Three-Phase Asynchronous Motors – Technical Requirements (excerpt from VIK Recommendation 1 as per March 2011),

Voltage

230 V/400 V*	± 5 %**	50 Hz, Δ/Y
400 V/690 V*	± 5 %**	50 Hz, Δ/Y
290 V/500 V		50 Hz, Δ/Y

* Rated voltage in accordance with DIN IEC 60038

** Rated voltage range

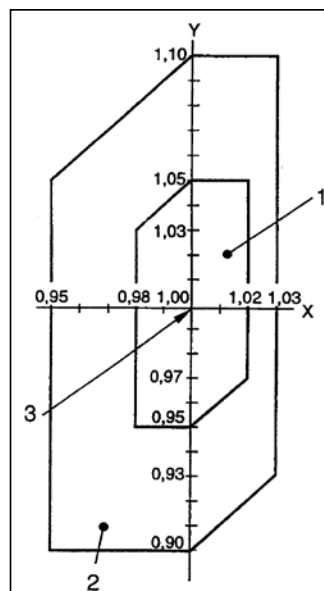

Voltage and frequency limits for motors in accordance with IEC/EN 60034-1

In accordance with IEC/EN 60034-1, a voltage tolerance of ± 10 % applies.

An alternative possibility is a marking such as

400/690 V ± 5 % (Zone A) Δ/Y .

This variant is used especially for explosion-protected motors complying with the VIK recommendation of 2011. In this case, assuming a voltage of 400 V, an overall voltage tolerance of ± 10 % and a **frequency tolerance of only ± 2 % of Range A according to IEC/EN 60034-1 would apply.**

The torque must be maintained without limitations across a further tolerance range of ± 5 %. No rated voltage range is required for motors with a rated voltage of 290 V/500 V.

In the case of explosion-protected motors for which a rated voltage range is specified, the motor warming at the tolerance limits (rated range limit plus additionally ± 5 %) must not exceed the permissible limit temperature. The specified permissible voltage tolerances of the motor must be observed.

Notes on marking of the IE classification (according to IEC/EN 60034-30-1)

Motors with more than one rated voltage/frequency/output combination may be assigned a rated efficiency and a rated efficiency class for each rated voltage/frequency/output combination. As a minimum requirement, however, the lowest efficiency value and the associated IE code (of all rated voltage/frequency/output combinations) must always be indicated on the rating plate. All efficiency values (50%, 75% and 100 % load) and their corresponding IE codes must be specified in the product documentation (catalogue or operating instructions). Rated voltage/frequency combi-

nations with the same magnetic flux and output, for example 230/400 V (delta/star) or 230/460 V (double-star/star), must only be assigned one rated efficiency and one efficiency class (IE code).

NOTE: In Japan, for example, the rating combination “200 V/50 Hz – 200 V/60 Hz – 220 V/60 Hz” is typical, while in Europe, the rating combination “380 V/50 Hz – 400 V/50 Hz – 415 V/50 Hz – 460 V/60 Hz” is sometimes used. For these examples, there will be either three or four efficiency ratings, respectively, and several different IE codes may apply.

Rated output

The specified rated output applies for continuous operation to IEC/EN 60034-1 and refers to a coolant temperature of 40 °C, installation at an altitude ≤ 1,000 m above sea level, operating frequency 50 Hz and rated voltage. The series K11R/ K21R, K10R/K20R and W... possess thermal reserves which permit the following type-dependent continuous loads:

- Output up to 10 % above rated output at coolant temperature 40 °C
- Rated output up to coolant temperature 50 °C
- Rated output at altitudes up to 2,500 m

In such cases, consultation with the manufacturer is recommended.

Alternative conditions do not apply in the case of explosion-protected motors. Such motors may only be operated up to the values specified on the rating plate.

Motor torque

The rated torque (in Nm) delivered at the motor shaft amounts to

$$M = 9550 \cdot \frac{P}{n}$$

where P = Rated output in kW
n = Speed in rpm

In the motor selection data, the starting, pull-up and break-down torques are given as multiples of the rated torque.

If the voltage deviates from its rated value, this results in an approximately quadratic change in the torque.

Ambient temperature

All VEM motors are suitable for ambient temperatures from -20 °C to +40 °C in their basic versions. Motors can be used at ambient temperatures down to -40 °C, provided they have been ordered specifically for such conditions.

In case of deviating ambient temperatures at installation sites below 1,000 m above sea level, the following factors are applied to determine the permissible output, depending on the thermal class:

Coolant temperature °C	10	15	20	25	30	35	40	45	50	55	60	70
Thermal class factor F	1.21	1.17	1.14	1.10	1.07	1.03	1.00	0.95	0.90	0.85	0.80	0.68

Factors for adjustment of the permissible output in case of deviating coolant temperatures

If frequent moisture condensation is to be expected at the place of motor installation, we recommend the use of a space heater or other suitable precautions.

Installation altitude

Unless specified otherwise by the customer, it is assumed that the place of installation is not more than 1,000 m above sea level. If the machine is to be operated at an altitude above 1,000 m but below 4,000 m above sea level, the rated output is subject to the adjustment factors specified in the table to the right:

In case of installation at altitudes > 4,000 m, the limit values for temperature rise must be agreed separately between the manufacturer and the customer.

Altitude above sea level in m	Coolant temperature in °C					
	< 30	30–40	45	50	55	60
1000	1.07	1.00	0.95	0.90	0.85	0.80
1500	1.04	0.97	0.93	0.89	0.84	0.79
2000	1.00	0.94	0.90	0.86	0.82	0.77
2500	0.96	0.90	0.86	0.83	0.78	0.74
3000	0.92	0.86	0.82	0.79	0.75	0.70
3500	0.88	0.82	0.79	0.75	0.71	0.67
4000	0.82	0.77	0.74	0.71	0.67	0.63

Adjustment factors for altitude/coolant temperature

Overload capacity

In accordance with IEC/EN 60034-1, all motors can be subjected to the following overload conditions:

- 1.5 x rated current for a duration of 2 minutes
- 1.6 x rated torque for a duration of 15 seconds

Rated efficiency and power factor

The efficiency η and the power factor $\cos \varphi$ are given in the lists of motor selection data.

Restarting with residual field and phase opposition

When an electric machine is switched off, a voltage system remains effective in its winding for a short time on account of the decaying magnetic field. Restarting could result in

Motor protection

Upon request, the following motor protection variants are possible:

- Motor protection with PTC thermistors as temperature sensors in the stator winding
- Bi-metal temperature sensor as normally closed or normally open contact in the stator winding (not for explosion-protected motors for the gas sector)

Duty cycles

Special duty cycles for switched operation, short-time operation or electric braking are possible upon request. IEC/EN 60034-1 defines the following nominal duty cycles, which take into account thermal and mechanical conditions:

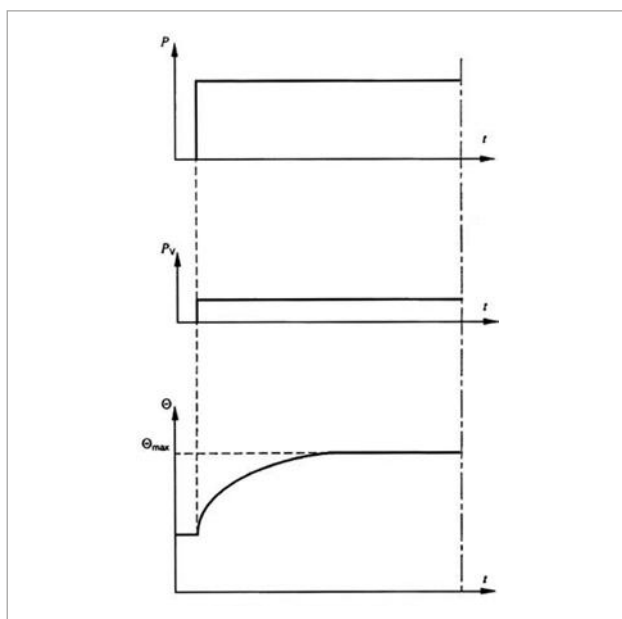

Both conditions apply for rated voltage and rated frequency

In the case of motors with IE classification, values are specified for the efficiency at 100/75/50 % load.

transient electrodynamic reactions in the machine. VEM motors can be restarted against a 100 % residual field after mains failure.

- KTY silicon sensors
- Resistance thermometer for winding or bearing temperature monitoring
- Bearing vibration diagnosis

Duty cycle S1 – Continuous duty

Operation with a constant load which remains effective for a sufficient duration for the machine to reach thermal equilibrium. If no duty cycle is indicated on the rating plate, the motor is designed for continuous duty S1.

In the motor selection data lists, the rated data are specified for this duty cycle.

P	Load
P_V	Electrical losses
Θ	Temperature
Θ_{max}	Maximum temperature
t	Time

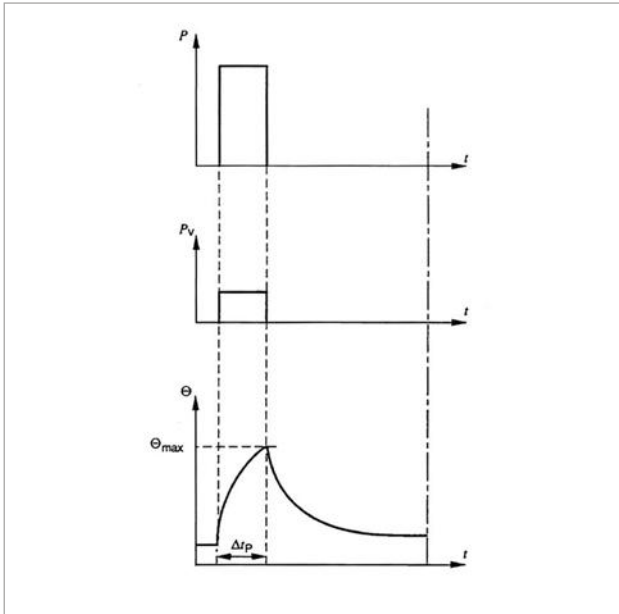

Duty cycle S2 – Short-time duty

Operation with a constant load which does not remain effective for a sufficient duration for the machine to reach thermal equilibrium, and a subsequent period of standstill with de-energised windings which is sufficient for the machine temperature to fall back to a level which deviates from the temperature of the coolant by less than 2 K. In case of duty cycle S2, the duration of operation must be specified.

- P Load
- P_V Electrical losses
- Θ Temperature
- Θ_{max} Maximum temperature
- t Time
- Δt_p Duration of operation at constant load

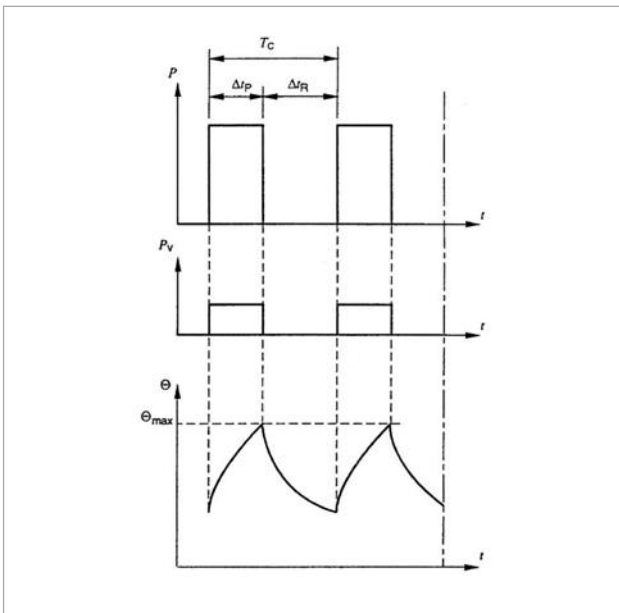

Duty cycle S3 – Intermittent periodic duty

Operation which comprises a succession of identical cycles, each of which consists of a period of operation with constant load and a period of standstill with de-energised windings, where the starting current does not significantly influence the temperature rise. The specification of this duty cycle must be accompanied by indication of the cyclic duration factor. Periodic duty means that the state of thermal equilibrium is not reached during the period of the load.

- P Load
- P_V Electrical losses
- Θ Temperature
- Θ_{max} Maximum temperature
- t Time
- T_C Cycle duration
- Δt_p Duration of operation at constant load
- Δt_R Duration of standstill with de-energised windings
- Cyclic duration factor = $\Delta t_p / T_C$

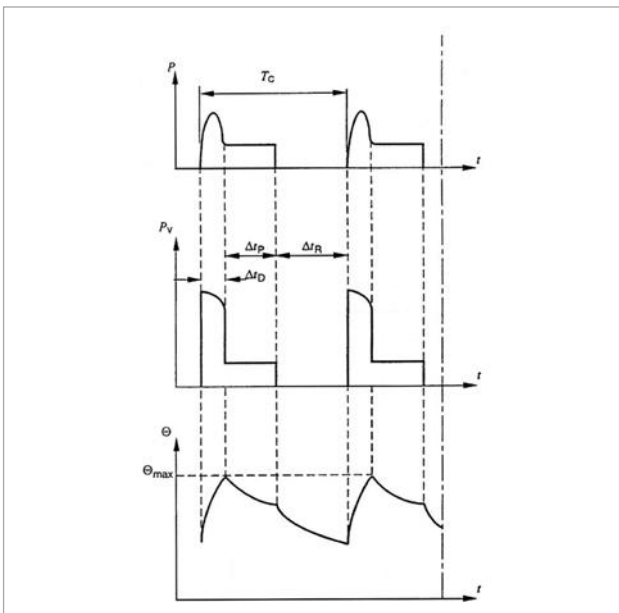

Duty cycle S4 – Intermittent periodic duty with starting

Operation which comprises a succession of identical cycles, each of which consists of a distinct starting period, a period of operation with constant load and a period of standstill with de-energised windings. The specification of this duty cycle must be accompanied by indication of the cyclic duration factor, the mass moment of inertia of the motor and the mass moment of inertia of the load, with the latter both referring to the motor shaft. Periodic duty means that the state of thermal equilibrium is not reached during the period of the load.

- P Load
- P_V Electrical losses
- Θ Temperature
- Θ_{max} Maximum temperature
- t Time
- T_C Cycle duration
- Δt_D Starting period
- Δt_p Duration of operation at constant load
- Δt_R Duration of standstill with de-energised windings
- Cyclic duration factor = $(\Delta t_D + \Delta t_p) / T_C$

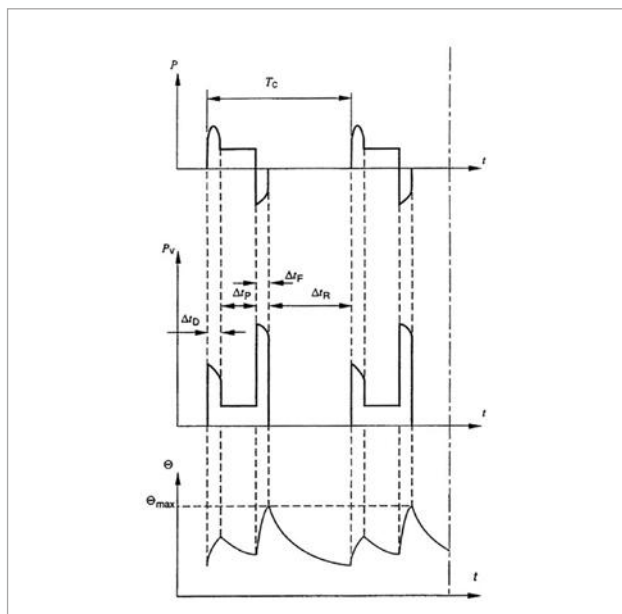

Duty cycle S5 – Intermittent periodic duty with electric braking

Operation which comprises a succession of identical cycles, each of which consists of a starting period, a period of operation with constant load, a period of electric braking and a period of standstill with de-energised windings. The specification of this duty cycle must be accompanied by indication of the cyclic duration factor, the mass moment of inertia of the motor and the mass moment of inertia of the load, with the latter both referring to the motor shaft. Periodic duty means that the state of thermal equilibrium is not reached during the period of the load.

P	Load
P _v	Electrical losses
Θ	Temperature
Θ _{max}	Maximum temperature
t	Time
T _C	Cycle duration
Δ t _D	Starting period
Δ t _P	Duration of operation at constant load
Δ t _F	Duration of electrical braking
Δ t _R	Duration of standstill with de-energised windings
	Cyclic duration factor = (Δ t _D + Δ t _P + Δ t _F)/T _C

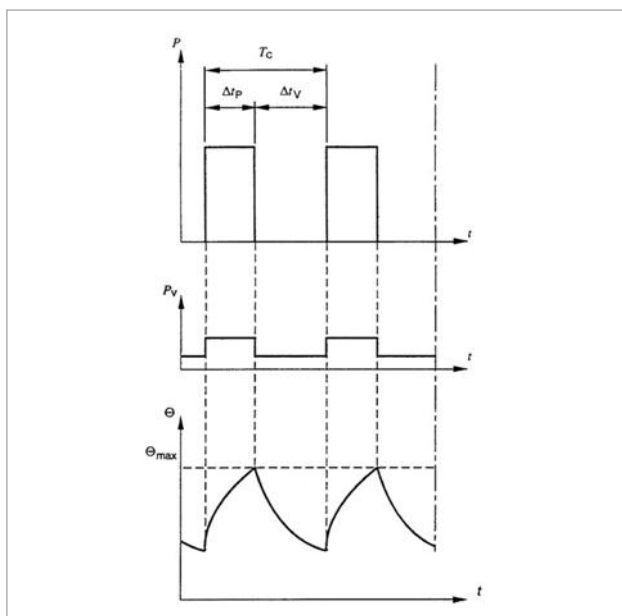

Duty cycle S6 – Continuous operation periodic duty

Operation which comprises a succession of identical cycles, each of which consists of a period of operation with constant load and a period of no-load operation. No standstill with de-energised windings occurs. The specification of this duty cycle must be accompanied by indication of the cyclic duration factor. Periodic duty means that the state of thermal equilibrium is not reached during the period of the load.

P	Load
P _v	Electrical losses
Θ	Temperature
Θ _{max}	Maximum temperature
t	Time
T _C	Cycle duration
Δ t _D	Starting period
Δ t _P	Duration of operation at constant load
Δ t _V	Duration of no-load operation
	Cyclic duration factor = Δ t _P /T _C

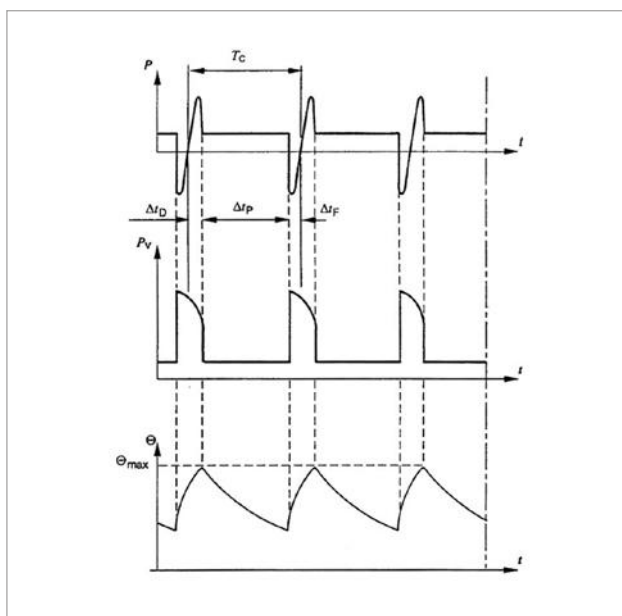

Duty cycle S7 – Continuous operation periodic duty with electric braking

Operation which comprises a succession of identical cycles, each of which consists of a starting period, a period of operation with constant load and a period of electric braking. No standstill with de-energised windings occurs. The specification of this duty cycle must be accompanied by indication of the mass moment of inertia of the motor and the mass moment of inertia of the load (both referring to the motor shaft).

P	Load
P _v	Electrical losses
Θ	Temperature
Θ _{max}	Maximum temperature
t	Time
T _C	Cycle duration
Δ t _D	Starting period
Δ t _P	Duration of operation at constant load
Δ t _F	Duration of electrical braking
	Cyclic duration factor = 1

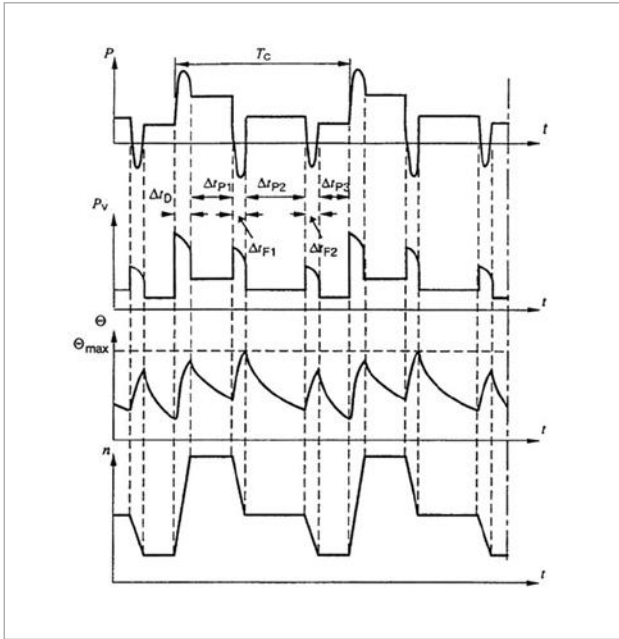

Duty cycle S8 – Continuous operation periodic duty with related changes in load and speed

Operation which comprises a succession of identical cycles, each of which consists of a period of operation with constant load and at a certain speed, followed by one or more periods of operation with other constant loads in accordance with different speeds. (This may be the case with pole-changing asynchronous motors, for example.) No standstill with de-energised windings occurs. The specification of this duty cycle must be accompanied by indication of the mass moments of inertia of the motor and load (both referring to the motor shaft), as well as the load, speed and cyclic duration factor for each relevant speed.

- P Load
- P_v Electrical losses
- Θ Temperature
- Θ_{max} Maximum temperature
- n Speed
- t Time
- T_c Cycle duration
- Δt_D Starting period
- Δt_P Duration of operation at constant load (P1, P2, P3)
- Δt_F Duration of electrical braking (F1, F2)

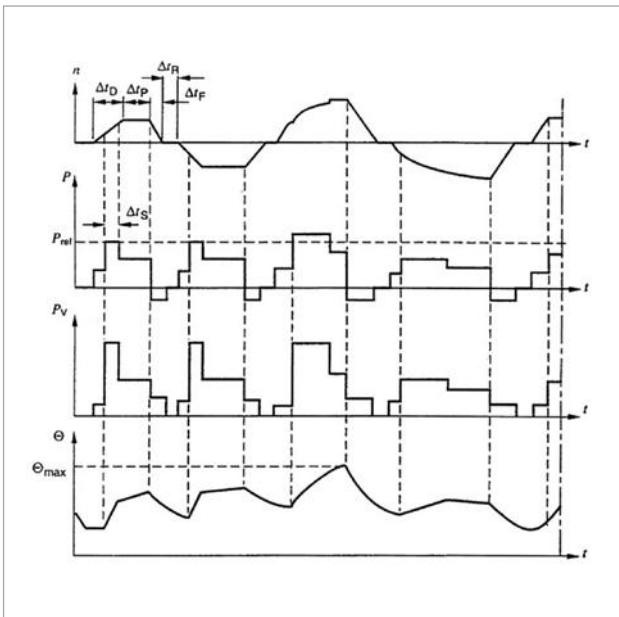

Duty cycle S9 – duty with non-periodic load and speed variations

Operation characterised by no more than four discrete loads (or equivalent loads), each of which remains effective for a sufficient duration for the machine to reach thermal equilibrium. The smallest load within this duty cycle may be zero (no-load operation or standstill with de-energised windings). For this duty cycle, a suitable constant load corresponding to duty cycle S1 must be selected as the reference value for the individual loads.

- P Load
- P_{ref} Reference load
- P_v Electrical losses
- Θ Temperature
- Θ_{max} Maximum temperature
- n Speed
- t Time
- Δt_D Starting period
- Δt_P Duration of operation at constant load
- Δt_F Duration of electrical braking
- Δt_R Duration of standstill with de-energised windings
- Δt_S Duration of overload

Duty cycle S10 – Operation with discrete constant loads and speeds

Operation characterised by no more than four discrete loads (or equivalent loads), each of which remains effective for a sufficient duration for the machine to reach thermal equilibrium. The smallest load within this duty cycle may be zero (no-load operation or standstill with de-energised windings).

For this duty cycle, a suitable constant load corresponding to duty cycle S1 must be selected as the reference value for the individual loads.

Paint finish

An attractive appearance combined with resilient corrosion protection, while at the same time taking into account all relevant demands relating to environmental protection and occupational health and safety – that is the essential objective to be met by all paint finishes applied to our motors. Paint finishes must withstand the most diverse stresses and influences in order to ensure long-term reliable protection. With the switch to low-solvent paint systems, VEM has adapted its production to the tightened demands of the 31st Ordinance on Implementation of the Federal Immission Control Act (Ordinance regarding the reduction of VOC emissions resulting from the use of organic solvents in specific installations – German Solvent Ordinance) [31. BImSchV] and is thus making an active contribution to the improvement of environmental protection.

Normal paint finish

- Suitable for climate group “Moderate” in accordance with IEC 60721-2-1
- Indoor and outdoor installation, moderate climate (short-time exposure to relative humidity up to 100 % at temperatures up to +30 °C; continuous exposure to relative humidity up to 85 % at up to +25 °C)

Special paint finish

- Suitable for climate group “Worldwide” in accordance with IEC 60721-2-1
- Outdoor installation in atmospheres with a general tendency to increased stress, tropical climate (short-time exposure to relative humidity up to 100 % at temperatures up to +35 °C; continuous exposure to relative humidity up to 98 % at up to +30 °C)

VEM paint systems provide lasting, high-performance corrosion protection. Their functional capabilities have been proven in exacting and comprehensive test series.

Customer-specific paint systems are always subject to prior consultation.

Nr.	Designation	Installation conditions
01/ 01S	„M“ Moderate Thermal class 155/180	Normal finish “M”, climate group “Moderate M” to DIN IEC 721-2 1 Indoor installation, outdoor installation under cover Corrosion class “C2 – Low” according to EN ISO 12944-2:1998 Finish 01 in RAL 7031 for thermal classes F and H Finish 01S for special colours, thermal class F only
02/ 02S	„W“ worldwide Thermal class 155/180	Climate-specific finish “W”, climate group “Worldwide” to DIN IEC 721-2-1 Outdoor installation in temperate climates, installation in damp rooms, industrial atmosphere, tropical climates, desert climates, cold climates, agriculture (MO, AS, SS, TII), VIK version, Roller table motors ARB, ARC, A100, A110, A10G, A11G, Corrosion class “C2–C3 – Low to medium” acc. to EN ISO 12944-2:1998, Finish 02 in RAL 7031 for thermal classes F and H, Finish 02S for special colours, thermal class F only
03	Customer request	Special paint system to customer specification
04	Special finish “Marine/ports”	Special finish for marine climates and port environments
06	“M”/“W” Thermal class 180	Climate-specific finish “M and W” to DIN IEC 721-2-1 special colours for thermal class H Corrosion class “C2–C3 – Low to medium” acc. to EN ISO 12944-2:1998 Finish 06 for special colours, thermal class H
07	Special finish “Chemicals” Thermal class 180	Special finish suitable for decontamination, extreme chemical and thermal resilience, high corrosion protection, Corrosion class “C3 – Medium” acc. to EN ISO 12944-2:1998
08	Primed	Motors without winding, built-on motors, primed motors with core in place
09 L	Light-duty offshore finish	Outdoor installation, UV-resistant, high corrosion protection, Corrosion class “C3–C4 – Medium to high” acc. to EN ISO 12944-2:1998
09 S	Heavy-duty offshore finish	Offshore applications, drilling rigs, further enhanced corrosion protection, UV-resistant, Corrosion class “C4/C5 – High to very high” (industry, marine) acc. to EN ISO 12944-2:1998
10 L	General Ex finish > 200 µm, light-duty offshore version	General Ex finish > 200 µm, Outdoor installation, UV-resistant, high corrosion protection Corrosion class “C3–C4 – Medium to high” acc. to EN ISO 12944-2:1998
10 S	General Ex finish > 200 µm, heavy-duty offshore version	General Ex finish > 200 µm, Offshore applications, drilling rigs, further enhanced corrosion protection, UV-resistant, Corrosion class “C4/C5 – High to very high” (industry, marine) acc. to EN ISO 12944-2:1998

01 Moderate WK F/H RAL 7031	01 S Moderate WK F	02 worldwide WK F/H RAL 7031 Special colour	04 Special finish	06 Moderate/ worldwide WK H RAL 7031 Special colour	07 Special finish	08 Primed	08 S Unpainted (component primer only)	09 L Light-duty offshore finish	09 S Heavy-duty offshore finish	10 L Special finish	10 S Special finish
Heat, indoors, outdoors under cover	Heat, indoors, outdoors under cover	Heat, outdoors, indoors with high humidity	Marine climate, ports	Heat, humidity, outdoors	Chemicals, heat, humidity, high corrosion protection	Prepared for further painting	Prepared for further painting	UV-resis- tant, outdoors, high corrosion protection	Offshore marine climate, further enhanced corrosion protection	General Ex finish > 200 µm, high corrosion protection	General Ex finish > 200 µm, further enhanced corrosion protection
> 60 µm	> 60 µm	> 90 µm	> 150 µm	> 130 µm	> 140 µm	> 60 µm		> 210 µm	> 240 µm	> 210 µm	> 240 µm
up to 120 °C short-time 160 °C	up to 100 °C short-time 120 °C	up to 120 °C short-time 160 °C	up to 100 °C short-time 140 °C	up to 120 °C short-time 160 °C	up to 120 °C short-time 160 °C			up to 100 °C short-time 140 °C	up to 100 °C short-time 140 °C	up to 100 °C short-time 140 °C	up to 100 °C short-time 140 °C
KK C2	KK C2	KK C2 – C3	KK C3 – C4	KK C2 – C3	KK C3			KK C4	KK C5	KK C4	KK C5
2K-EP TC 30 µm	2K-PUR TC 30 µm	2K-PUR TC 60 µm	2K-EP primer 80 µm	2K-EP primer. 40 µm	2K-EP primer. 40 µm	1K-primer 30 µm		2K-EP primer 100 µm	2K-EP primer 110 µm	2K-EP 40 µm	2K-EP 50 µm
Grey cast iron/fan cowls: Water-thinned primers, approx. 30 µm			KTL primer approx. 30 µm	Grey cast iron/fan cowls: Water-thinned primers, approx. 30 µm				KTL primer approx. 30 µm	2K-EP zinc dust 50 µm	KTL primer approx. 30 µm	2K-EP zinc dust 50 µm
Surfaces must be dry and free of dirt, rust, grease, scale and release agent / Aluminium terminal boxes and aluminium terminal box covers: Washed and Metaclean or HAKUPUR 700											

Paint systems used by VEM motors Thurm GmbH, motor sizes 56...132

01 Moderate WK F/H RAL 7031	01 S Moderate WK F	02 worldwide WK F/H RAL 7031	02 S worldwide WK F Special colour*	04 Special finish	06 Moderate/ worldwide WK H Special colour*	07 Special finish	08 Primed	09 L Light-duty offshore finish	09 S Heavy-duty offshore finish	10 L Special finish	10 S Special finish
Heat, indoors, outdoors under cover	Heat, indoors, outdoors under cover	Heat, outdoors, indoors with high humidity	Heat, outdoors, indoors with high humidity	Marine climate, ports	Heat, humidity, outdoors	Chemicals, Heat, humidity, high corrosion protection	Prepared for further painting	UV-resis- tant, out- doors, high corrosion protection	Offshore marine climate, further enhanced corrosion protection	General Ex finish > 200 µm, high corrosion protection	General Ex finish > 200 µm, further enhanced corrosion protection
> 70 µm	> 70 µm	> 110 µm	> 110 µm	> 150 µm	> 110 µm	> 150 µm	> 70 µm	> 210 µm	> 240 µm	> 210 µm	> 240 µm
up tp 120 °C short-time 180 °C	up tp 100 °C short-time 120 °C	up tp 120 °C short-time 180 °C	up tp 100 °C short-time 120 °C	up tp 80–90 °C short-time 130 °C	up tp 120 °C short-time 180 °C	up tp 120 °C short-time 180 °C		up tp 100 °C short-time 140 °C	up tp 100 °C short-time 140 °C	up tp 100 °C short-time 140 °C	up tp 100 °C short-time 140 °C
KK C2	KK C2	KK C2 – C3	KK C2 – C3	KK C3 – C4	KK C2 – C3	KK C3		KK C4	KK C5	KK C4	KK C5
2K-EP TC 40 µm	2K-PUR TC 40 µm	2K-EP primer 40 µm	2K-EP primer 40 µm	2K-EP, ceramic- filled 120 µm	2K-EP TC 40 µm	2K-EP primer 80 µm	2K-EP primer 40 µm	2K-EP primer 100 µm	2K-EP primer 110 µm	2K-EP primer 40 µm	2K-EP primer 50 µm
Grey cast iron/fan cowls: Water-thinned primers, approx. 30 µm Sheet steel terminal boxes: Powder-coated											
Grit blasting with SA 2.5/SIS 055900 for grey cast iron parts Cleaning/pickling for sheet metal parts										2K-EP zinc dust 50 µm	2K-EP zinc dust 50 µm
								2K-PUR TC 80 µm	2K-PUR TC 80 µm	2K-PUR TC 40 µm	2K-PUR TC 40 µm
								2K-PU conductive paint, min. 100 µm		2K-PU conductive paint, min. 100 µm	
								2K-PU conductive paint, min. 100 µm		2K-PU conductive paint, min. 100 µm	

1

Special colour*: Paint finish 01 not available in RAL 1000 to 2011, RAL 7047, 9001, 9002, 9005, 9010, 9011, 9016, 9017 and light ivory textured paint 1015, KK

Paint systems used by VEM motors GmbH, motor sizes 160...400

The specified layer thicknesses are the target thicknesses which are normally attained by the painting process. Certain process-inherent fluctuations are inevitable, however, due to the geometric properties of the final product and the realisation of spray painting by hand.

Coating thickness measurements performed for our customers indicate merely the average value from several individual measurements.

If no colour is specified, all motors are supplied in **RAL 7031 "Blue grey"**.

If a different colour is required, the corresponding RAL number and colour designation must be specified at the time of ordering.

A top coat is only applied to the inside of the fan cowl and the N-end of the motor with paint systems 04 and 07. With paint system 09L/10L, only the N-end of the motor receives a top coat. Paint systems 09S/10S comprise printing of the inside of the fan cowl and full realisation of the paint coating (up to 200 µm) also on the N-end of the motor.

Modular construction of different series and modifications

The design concepts of the different series provide for the optional incorporation of components such as encoders, tacho generators, brakes, speed monitors or forced ventilation units to solve the customer's individual control tasks.

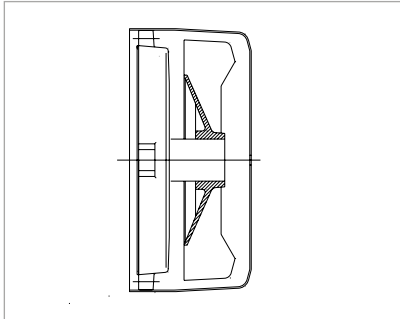

Standard version
Type of cooling IC 411, self-ventilated

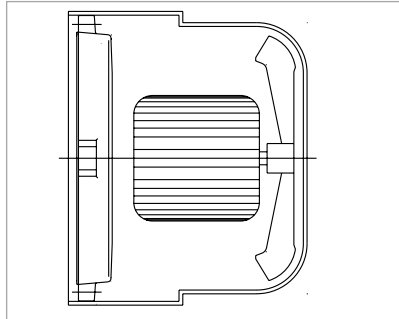

Special version
Type of cooling IC 416, forced ventilation

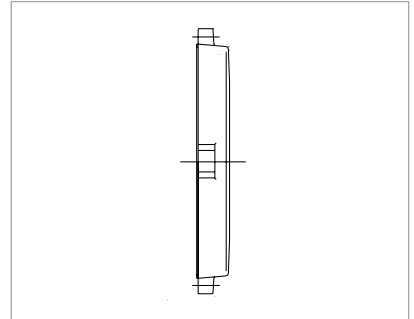

Special version
Type of cooling IC 410, non-ventilated

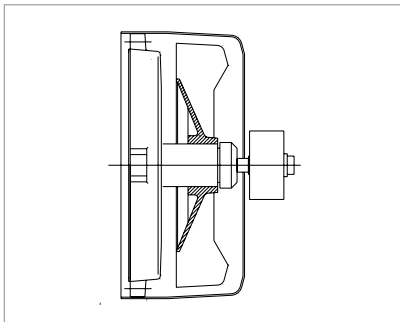

Special version
Type of cooling IC 411, self-ventilated with built-on incremental encoder

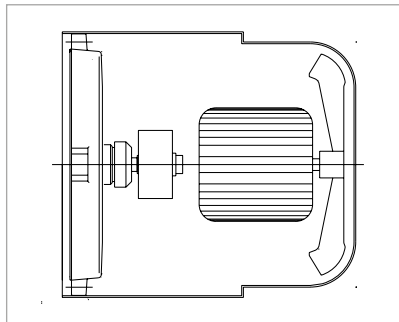

Special version
Type of cooling IC 416, forced ventilation with built-on incremental encoder

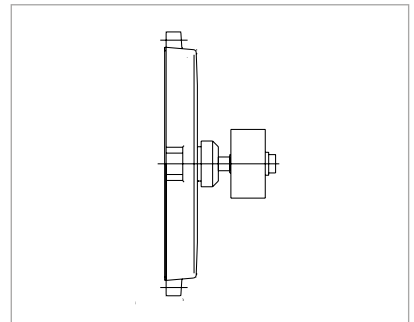

Special version
Type of cooling IC 410, non-ventilated with built-on incremental encoder

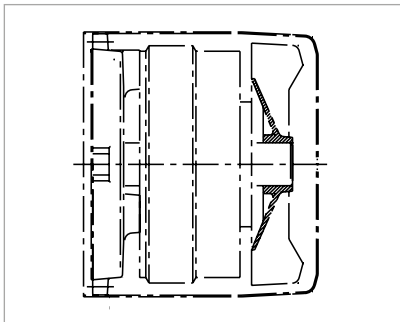

Special version
Type of cooling IC 411, self-ventilated with built-on brake

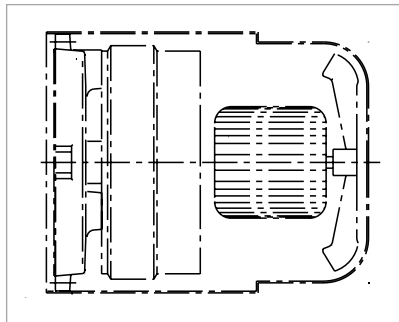

Special version
Type of cooling IC 416, forced ventilation with built-on brake

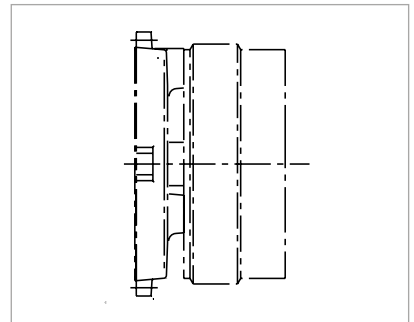

Special version
Type of cooling IC 410, non-ventilated with built-on brake

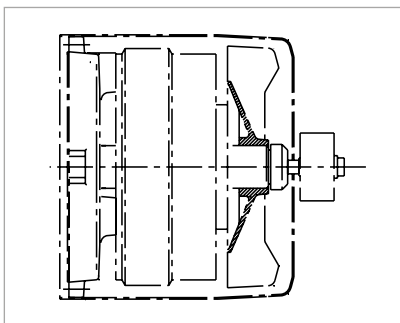

Special version
Type of cooling IC 411, self-ventilated with built-on brake and incremental encoder

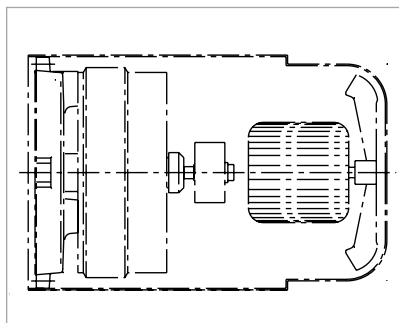

Special version
Type of cooling IC 416, forced ventilation with built-on brake and incremental encoder

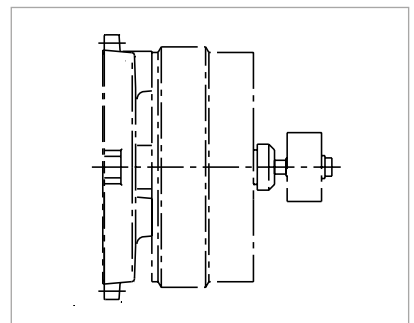

Special version
Type of cooling IC 410, non-ventilated with built-on brake and incremental encoder

Maintenance

Attention is drawn expressly to the safety notes and instructions, and here in particular to the procedures for safe isolation, safeguarding against accidental restarting, and checking the proper disconnection of all components connected to a voltage source. When a motor is disconnected from the mains supply for maintenance purposes, particular care must be taken to ensure that any auxiliary circuits, e.g. space heaters, forced ventilation fans or brakes, are similarly disconnected from their power supply. If it is necessary to dismantle the motor to perform maintenance work, the sealing compound left on the centring edges must be removed. New sealing compound of a

suitable type is to be used for sealing when the motor is reassembled. Any copper sealing rings must always be refitted.

Careful and regular maintenance and inspection is imperative, so as to be able to detect and rectify any arising problems in good time before further damage is caused. As the operating conditions are not exactly defined, it is only possible to specify general maintenance intervals, under the assumption of trouble-free operation. These intervals must always be adapted in accordance with the local circumstances (contamination, loads, etc.).

What is to be done?	Regular interval	Max. interval
Initial inspection	After approx. 500 operating hours	At the latest after six months
Check of air passages and motor surface	Depending on types of local contamination	
Relubrication (option)	See rating plate or lubrication plate	
Main inspection	Approx. 8000 operating hours	Once a year
Drain condensation	Depending on climatic conditions	

Inspections

Initial inspection

In accordance with the specifications, an initial inspection of the motor should be performed after approx. 500 operating hours, but at the latest after six months.

The following checks are to be performed with the motor at standstill:

- Check the foundation. There must be no cracks or other damage such as depressions or the like.

The following checks are to be performed with the motor running:

- Check the electrical parameters.
- Check the bearing temperatures. It is to be determined whether the permissible bearing temperatures are exceeded during operation of the motor.
- Check for unusual noises during operation. An acoustic check is performed to determine whether the quiet running of the motor has deteriorated.

If the checks reveal any deviations from the values specified in the operating and maintenance manual, or any other defects or errors, these deviations and defects must be rectified immediately.

Main inspection

In accordance with the specifications, a main inspection should be performed once a year or after approx. 10,000 operating hours.

The following checks are to be performed with the motor at standstill:

- Check the foundation. There must be no cracks or other damage such as depressions or the like.
- Check the alignment of the motor. The alignment must lie within the specified tolerances.

Long-term storage (over 12 months)

If long-term storage is necessary, motors must be protected from vibration and kept in closed, dry rooms at temperatures between -20 and +40 °C and in an atmosphere free from aggressive gases, vapours, dusts and salts. Motors should preferably be transported and stored in their original

- Check the mounting screws and bolts. All screws and bolts which are used to make mechanical and electrical joints and connections must be properly tight (see also the table of tightening torques for screws and bolts under Section 11 "Commissioning" of the operating and maintenance manual).
- Check the cables and the insulation materials. It is to be checked whether the cables and the insulation materials used are in a good and proper condition. They must not display discolouration, and in particular not burn marks, and must not be broken, cracked or otherwise damaged.
- Check the insulation resistance. When checking the insulation resistance of the winding, observe the specifications given in the operating and maintenance manual (Section 9).
- Depending on the grease quality and the bearings of the motor, it may also be necessary to replace the grease of the anti-friction bearings after 10,000 operating hours (see also Section 13 "Bearings and lubrication" of the operating and maintenance manual). Otherwise, the specified relubrication intervals for the anti-friction bearings must be observed separately, as they deviate from the inspection intervals.

The following checks are to be performed with the motor running:

- Check the electrical parameters.
- Check the bearing temperatures. It is to be determined whether the permissible bearing temperatures are exceeded during operation of the motor.
- Check for unusual noises during operation. An acoustic check is performed to determine whether the quiet running of the motor has deteriorated.

If the checks reveal any deviations from the values specified in the operating and maintenance manual, or any other defects or errors, these deviations and defects must be rectified immediately.

packaging. Storage and transport resting on the fan cowl is not permissible. Unprotected metal surfaces, for example shaft ends and flanges, are to be provided with long-term corrosion protection, in addition to the temporary corrosion protection applied before motors leave the factory.

If the motors are subject to condensation under the given ambient conditions, precautions are to be taken to protect the motors against moisture. In such cases, the motors must be specially packed in air-tight welded foil or under plastic foil with appropriate desiccants. Desiccant sachets are also to be placed in the motor terminal boxes.

For transport, the ring bolts/load beams of the motors are to be used together with appropriate lifting tackle. The ring

Disposal

The applicable national regulations are to be observed with regard to disposal of the machines.

It is furthermore to be ensured that oils and greases are collected for disposal in accordance with the corresponding regulations on waste oils. They must not be contaminated with solvents, cold cleaners and paint residues. The individual materials should be segregated for recycling. The most important components are grey cast iron (housing), steel (shaft, stator and rotor lamination, small parts), aluminium (rotor), copper (windings) and plastics (insulation materials, such as polyamide, polypropylene, etc.). Electronic components such as circuit boards (converter, sensors, etc.) are recycled separately.

Fits: Shaft ends

Shaft ends	up to Ø 48	k6
	from Ø 55	m6
Mating parts		H7

Tolerances – Electrical parameters

According to DIN EN 60034-1, the following tolerances are permissible:

Efficiency (when determined indirectly)	-0,15 (1- η) at $P_N \leq 150$ kW -0,1 (1- η) at $P_N > 150$ kW
Power factor	$\frac{1-\cos\varphi}{6}$ min. 0,02 max. 0,07
Total losses (applicable for machines with rated outputs ≥ 150 kW)	+10 %
Slip (with nominal load and at operating temperature)	± 20 % at $P_N \geq 1$ kW ± 30 % at $P_N < 1$ kW
Starting current (with intended starting circuit)	+20 % no lower limit
Starting torque	-15 % and +25 %
Pull-up torque	-15 %
Breakdown torque	-10 % (M_K/M_N still at least 1.6 after application of this tolerance)
Moment of inertia	± 10 %
Noise level (sound pressure level at measuring surface)	+3 dB (A)

These tolerances are applicable to the warranted values for three-phase asynchronous motors, taking into account necessary manufacturing tolerances and possible deviations in the raw materials used. The standard includes the following notes:

1. It is not intended that warranties necessarily have to be given for all or any of the items involved. Quotations including warranted values subject to tolerances should say so, and the tolerances should be in accordance with the table.

bolts/load beams are only intended for lifting of the bare motor without additional built-on parts such as base plate, gearing, etc.

Motors with reinforced bearings are supplied with a transport brace. The transport brace on the shaft end should only be removed after assembly of the motor and prior to the first starting.

Warranty, repairs, spare parts

Our authorised service workshops are responsible for all warranty repairs, unless expressly agreed otherwise. They can also be contacted in connection with any other repairs which may become necessary. Information on our customer service network can be requested from our central offices. An overview of the available spare parts is to be found in Chapter 15. Maintenance in accordance with the instructions given in the section "Maintenance" is not considered a breach of the warranty stipulations. It thus cannot be deemed to release the manufacturer from any agreed warranty obligations.

- Attention is drawn to variations in the interpretations of the terms "warranty" and "guarantee". In some countries, a distinction is made between declared and typical values.
- Where a tolerance is stated in only one direction, the value is not limited in the other direction.

Tolerances – Mechanical parameters

Dimension symbol to DIN EN 50347	Meaning of dimension	Fit or tolerance
B [a]	Spacing of fixing holes for housing feet in axial direction	±1 mm
P [a ₁]	Diameter or width across corners of flange	- 1 mm
A [b]	Spacing of fixing holes for housing feet transverse to axial direction	±1 mm
N [b ₁]	Diameter of centring edge of mounting flange	up to diameter 230 mm j6 from diameter 250 mm h6
D, DA [d, d ₁]	Diameter of cylindrical shaft end	up to diameter 48 mm k6 from diameter 55 mm m6
M [e ₁]	Pitch circle diameter of mounting flange	±0,8 mm
AB [f], AC [g]	Greatest width of motor (without terminal box)	+2 %
H [h]	Shaft height (bottom edge of foot to centre of shaft end)	up to 25–0,5 mm over 250–1 mm
L, LC [k, k ₁]	Total motor length	+1 %
HD [p]	Total motor height (bottom edge of foot, housing or flange to highest point of motor)	+2 %
K, K' [s, s ₁]	Diameter of mounting holes of foot or flange	+3 %
GA, GC [t, t ₁]	Bottom edge shaft end to top edge key	+0,2 mm
F, FA [u, u ₁]	Width of key	h9
C, CA [w ₁ , w ₂]	Distance from centre of first foot mounting hole to shaft shoulder or flange face	±3,0 mm
	Distance from shaft shoulder to flange face with fixed bearing at D-end	±0,5 mm
	Distance from shaft shoulder to flange face	±3,0 mm
m	Motor mass	-5 to +10 %

Noise values, Sound pressure level L_{pA}

for motors IE3-W41R, IE3-W42R in normal version

IE3-	L_{pA} dB	IE3-	L_{pA} dB	IE3-	L_{pA} dB	IE3-	L_{pA} dB
2-pole		4-pole		6-pole		8-pole	
W41R 56 G 2	46						
W42R 63 K 2	46	W42R 63 K 4		W41R 63 G 6	38		
W41R 63 K 2	48	W41R 63 G 4	40				
W41R 63 G 2	48						
W42R 71 K 2	50	W42R 71 K 4	46	W42R 71 K 6	42	W41R 71 G 8	38
W41R 71 K 2	53	W41R 71 K 4	46	W41R 71 K 6	42		
W41R 71 GY 2	53	W41R 71 GY 4	46	W41R 71 GY 6	42		
W41R 71 G 2	53	W41R 71 G 4	46	W41R 71 G 6	42		
W42R 80 K 2	53	W41R 80 K 4	50	W41R 80 K 6	46	W42R 80 K 8	46
W41R 80 K 2	55	W41R 80 G 4	50	W41R 80 G 6	46	W41R 80 G 8	46
W41R 80 GY 2	55	W41R 80 GX 4	50				
WE1R 80 G 2	55						
W42R 90 S 2	58	W41R 90 SY 4	54	W41R 90 SY 6	51	W42R 90 SY 8	50
W41R 90 S 2	60	W41R 90 S 4	54	W41R 90 S 6	51	W41R 90 S 8	50
W41R 90 LY 2	60	W41R 90 L 4	54	W41R 90 L 6	51	W41R 90 L 8	50
W41R 90 L 2	60	W41R 90 LX 4	54				
W42R 100 LY 2	63	W41R 100 LY 4	58	W41R 100 LX 6	52	W41R 100 LY 8	52
W41R 100 L 2	63	W41R 100 L 4	58			W21R 100 L 8	52
		W41R 100 LW 4	58			W21R 100 LW 8	52
		W41R 100 L 4	58			W21R 100 LX 8	52
		W41R 100 LZ 4	58				
W41R 112 MY 2	67	W41R 112 MW4	60	W41R 112 MV 6	56	W21R 112 M 8	56
W41R 112 M 2	67	W41R 112 M 4	60	W41R 112 MZ 6	56	W41R 112 MZ 8	56
W40R 112 M 2	67						
W41R 112 MX 2	67						
W41R 132 S 2T	70			W41R 132 S 6	58	W41R 132 S 8	65
W41R 132 S 2	70						
		W41R 112 M4	58	W41R 112 M6	55		
		W41R 132 S4	56	W41R 132 S6	55	W41R 132 S8	56
W41R 132 SX2	66						
		W41R 132 M4	56	W41R 132 M6	55	W41R 132 M8	56
		W41R 132 MX4	-	W41R 132 MX6	56	W41R 132 MX8	-
W41R 160 M2	68	W41R 160 M4	61	W41R 160 M6	56	W41R 160 M8	58
W41R 160 MX2	68					W41R 160 MX8	58
W41R 160 L2	68	W41R 160 L4	61	W41R 160 L6	57	W41R 160 L8	62
W41R 180 M2	72	W41R 180 M4	62				
		W41R 180 L4	62	W41R 180 L6	61	W41R 180 L8	58
W41R 200 L2	74	W41R 200 L4	66	W41R 200 L6	63	W41R 200 L8	59
W41R 200 LX2	74	W41R 200 LX4	-	W41R 200 LX6	63		
		W41R 225 S4	66			W41R 225 S8	60
W41R 225 M2	72	W41R 225 M4	66	W41R 225 M6	64	W41R 225 M8	58
W41R 250 M2	74	W41R 250 M4	65	W41R 250 M6	65	W41R 250 M8	59
W41R 280 S2	74	W41R 280 S4	65	W41R 280 S6	73	W41R 280 S8	63
W41R 280 M2	74	W41R 280 M4	68	W41R 280 M6	73	W41R 280 M8	63
W41R 315 S2	75	W41R 315 S4	68	W41R 315 S6	71	W41R 315 S8	65
W41R 315 M2	75	W41R 315 M4	68	W41R 315 M6	71	W41R 315 M8	74
W41R 315 MX2	76	W41R 315 MX4	70	W41R 315 MX6	72	W41R 315 MX8	74
W41R 315 MY2	76	W41R 315 MY4	70			W41R 315 MY8	74
W41R 315 L2	76	W41R 315 L4	76	W41R 315 L6	72	W41R 315 L8	74
W41R 315 LX2	76	W41R 315 LX4	76				
		W41R 355 MY4	78			W41R 355 MY8	72
W41R 355 M2G	77 ¹⁾	W41R 355 M4	78	W41R 355 M6	72	W41R 355 M8	72
W42R 355 MX2G	77 ¹⁾	W42R 355 MX4	78	W42R 355 MX6	72	W42R 355 MX8	72
W42R 355 L2G	77 ¹⁾	W42R 355 L4	78	W42R 355 L6	72	W42R 355 L8	72
W42R 355 LX2G	77 ¹⁾	W42R 355 LX4	78	W42R 355 LX6	72		
				W42R 400 MY6	78		
W42R 400 M2G	79 ¹⁾	W42R 400 M4	78	W42R 400 M6	78	W42R 400 M	***)
W42R 400 MX2G	79 ¹⁾	W42R 400 MX4	78	W42R 400 MX6	78	W42R 400 MX	***)
W42R 400 L 2G	79 ¹⁾	W42R 400 L 4	78	W42R 400 L 6	78		

¹⁾ With axial fan, direction-dependent version

The noise values specified in the tables refer to operation at rated output, rated voltage and 50 Hz, with a tolerance of +3 dB.

Noise measurements in accordance with DIN EN ISO 1680

***) upon request

Noise values, Sound pressure level L_{pA}

for motors IE2-W..R in normal version

IE2-	L_{pA} dB	IE2-	L_{pA} dB	IE2-	L_{pA} dB	IE-	L_{pA} dB
2-pole		4-pole		6-pole		8-pole	
WE2R 56 G 2	46						
W21R 56 G 2	46						
WE2R 63 K 2	46	WE2R 63 K 4	40				
W21R 63 K 2	48	W21R 63 K 4	40				
WE2R 63 G 2	46	WE1R 63 GY 4	40				
W21R 63 G 2	48	W21R 63 G 4	40	WE2R 63 G 6	38		
WE2R 71 K 2	50	WE2R 71 K 4	46	WE2R 71 K 6	42		
W21R 71 K 2	53	W21R 71 K 4	46	W21R 71 K 6	42		
WE2R 71 G 2	50	WE1R 71 GY 4	46	WE2R 71 G 6	42	WE2R 71 G 8	38
W21R 71 G 2	53	W21R 71 G 4	46	W21R 71 G 6	42		
WE2R 80 K 2	53	WE2R 80 K 4	50	WE2R 80 K 6	46	WE2R 80 K 8	46
W21R 80 K 2	55	W21R 80 K 4	50	W21R 80 K 6	46		
WE2R 80 G 2	53	WE1R 80 GY 4	50	WE1R 80 GY 6	46		
W41R 80 G 2	55	W21R 80 G 4	50	W21R 80 G 6	46	WE2R 80 G 8	46
WE2R 90 S 2	58	WE2R 90 S 4	54	WE2R 90 S 6	51	WE2R 90 S 8	50
W21R 90 S 2	60	WE1R 90 S 4	54	W21R 90 S 6	51	W21R 90 S 8	50
WE2R 90 L 2	58	WE1R 90 LW 4	54	WE1R 90 LW 6	51	WE2R 90 L 8	50
WE1R 90 L 2	60	WE1R 90 L 4	54	W21R 90 L 6	51	W21R 90 L 8	50
WE2R 100 LY 2		W21R 100 S 4	58	WE2R 100 LW 6	52	WE2R 100 L 8	52
WE1R 100 L 2	63	WE1R 100 L 4	58	W21R 100 LX 6	62	W21R 100 L 8	52
		WE1R 100 LW 4	58	W21R 100 LV 6	55	WE2R 100 LY 8	52
		WE1R 100 LX 4	58			W21R 100 LX 8	52
WE1R 112 M 2	64	WE1R 112 MZ 4	60	WE1R 112 MX 6	54	WE2R 112 M 8	56
WE1R 112 MX 2	64	WE2R 112 M 4	60	W21R 112 MV 6	54	W21R 112 MV 8	56
WE1R 112 ML 2	64	WE1R 112 MW4	60	WE1R 112 MZ 6	54		
WE1R 112 MV 2	64	WE1R 112 MX 4	60	WE1R 112 M 6	54		
WE1R 112 MW 2	70						
WE1R 132 SY 2T	66	WE2R 132 SY 4	63	WE1R 132 SX6T	54		
WE1R 132 S 2T	66	WE2R 132 S 4	63	W21R 132 S 6	54	W21R 132 S 8	65
WE2R 132 S 2	66			WE2R 132 M 6	54	WE2R 132 M 8	65
WE1R 132 S 2T	70						
WE1R 132 SX2	66	WE1R 132 S4	58	WE1R 132 S6	55	WE1R 132 S8	57
		WE2R 132 S4	57	WE1R 132 M6	55	WE1R 132 M8	59
		WE1R 132 M4	58	WE2R 132 M6	55	WE2R 132 M8	57
				WE1R 132 MX6	56		
WE1R 160 M2	67	WE1R 160 M4	62	WE1R 160 M6	55	WE1R 160 M8	58
WE1R 160 MX2	67	WE2R 160 M4	57	WE2R 160 M6	55	WE1R 160 MX8	58
WE1R 160 L2	67	WE1R 160 L4	62	WE1R 160 L6	57	WE2R 160 MX8	58
		WE2R 160 L4	61	WE2R 160 L6	62	WE1R 160 L8	58
WE1R 180 M2	72	WE1R 180 M4	63	WE1R 180 L6	62	WE1R 180 L8	58
		WE2R 180 M4	63	WE2R 180 L6	57	WE2R 180 L8	58
		WE1R 180 L4	63				
WE1R 200 L2	72	WE1R 200 L4	66	WE1R 200 L6	62	WE1R 200 L8	58
WE2R 200 LX2	72			WE1R 200 LX6	64		
				WE2R 200 LX6	62		
WE1R 225 M2	74	WE1R 225 S4	67	WE1R 225 M6	64	WE1R 225 S8	60
		WE1R 225 M4	67	WE2R 225 M6	65	WE2R 225 S8	59
		WE2R 225 M4	67			WE1R 225 M8	59
						WE2R 225 M8	61
WE1R 250 M2	74	WE1R 250 M4	68	WE1R 250 M6	65	WE1R 250 M8	61
		WE2R 250 M4	67	WE2R 250 M6	65	WE2R 250 M8	58
WE1R 280 S2	75	WE1R 280 S4	70	WE1R 280 S6	65	WE1R 280 S8	61
WE1R 280 M2	75	WE1R 280 M4	70	WE1R 280 M6	73	WE1R 280 M8	65
WE1R 315 S2	78	WE1R 315 S4	71	WE1R 315 S6	73	WE1R 315 S8	65
WE1R 315 M2	78	WE1R 315 M4	71	WE1R 315 M6	73	WE1R 315 M8	65
WE1R 315 MX2	78	WE1R 315 MX4	71	WE1R 315 MX6	71	WE1R 315 MX8	74
WE1R 315 MY2	79	WE1R 315 MY4	76	WE1R 315 MY6	71	WE1R 315 MY8	74
WE1R 315 L2	79	WE1R 315 L4	76	WE1R 315 L6	71	WE1R 315 L8	74
WE1R 315 LX2	79	WE1R 315 LX4	76	WE1R 315 LX6	71	WE1R 315 LX8	74
WE2R 355 M2G	77 ¹⁾	WE2R 355 M4	78	WE2R 355M6	72	WE2R 355M8	72
WE2R 355 MX2G	77 ¹⁾	WE2R 355 MX4	78	WE2R 355MX6	72	WE2R 355MX8	72
WE2R 355 LY2G	77 ¹⁾	WE2R 355 LY4	78	WE2R 355LY6	72	WE2R 355LY8	72
WE2R 355 L2G	77 ¹⁾	WE2R 355L4	78				

¹⁾ With axial fan, direction-dependent version

The noise values specified in the tables refer to operation at rated output, rated voltage and 50 Hz, with a tolerance of +3 dB. Noise measurements in accordance with DIN EN ISO 1680

Noise values, Sound pressure level L_{pA}

for motors (IE1-)K21R, (IE1-)KU1R, (IE1-)K22R in normal version

	L_{pA} dB	L_{pA} dB	L_{pA} dB	L_{pA} dB
	2-pole	4-pole	6-pole	8-pole
63 K	46	41	40	-
63 G	46	41	40	-
71 K	48	42	41	37
71 G	48	42	41	37
80 K	52	44	41	40
80 G	52	44	41	40
90 S	56	49	43	42
90 L	56	49	43	42
100 L	59	50	49	47
100 LX	-	50	-	47
112 M	61	53	51	50
112 MX	61	-	-	-
132 S	65	58	54	52
132 SX	65	-	-	-
132 M	-	60	54	52
132 MX	-	-	56	-
160 M	66	60	56	57
160 MX	67	-	-	57
160 L	67	62	61	57
180 M	-	62	-	-
180 L	-	-	61	58
180 M	70	-	-	-
180 L	-	64	-	-
200 L	73	64	62	61
200 LX	73	-	62	-
225 S	-	66	-	59
225 M	74	66	63	59
250 M	74	68	63	63
280 S	75	69	65	61
280 M	75	69	65	61
315 S	78	72	68	65
315 M	78	72	68	65
315 MX	79	76	70	65
315 MY	79	76	68	66
315 L	79	76	68	66
315 LX	79	76	68	66
355 MY, M, MX ²⁾	77 ¹⁾	77	70	68
355 LY, L ²⁾	77 ¹⁾	77	70	68

¹⁾ With axial fan, direction-dependent version

²⁾ Series (IE1-)K22R

Low-noise version ¹⁾

	L_{pA} dB
	2-pole
200 LX	65
225 S	-
225 M	65
250 M	65
280 S	66
280 M	66
315 S	68
315 M	68
315 MX	68
315 MY	68
315 L	70
315 LX	68

Low voltage electrical machines

The noise values specified in the tables refer to operation at rated output, rated voltage and 50 Hz, with a tolerance of +3 dB. Noise measurements in accordance with DIN EN ISO 1680

Noise values, Sound pressure level L_{pA}

for motors (IE1-)K20R, (IE1-)KU0R in normal version

	L_{pA} dB	L_{pA} dB	L_{pA} dB	L_{pA} dB
	2-pole	4-pole	6-pole	8-pole
56 K	46	41	40	-
56 G	46	41	40	-
63 K	48	42	41	37
63G	48	42	41	37
71 K	52	44	41	40
71 G	52	44	41	40
80 K	56	49	43	42
80 G	56	49	43	42
90 L	59	50	49	47
100 S	61	50	-	47
100 L	61	53	51	50
100 LX	-	-	-	-
112 M	65	58	54	52
112 MX	-	-	54	52
132 S	66	60	56	57
132 M	66	60	56	57
160 S	67	62	61	57
160 M	67	62	61	58
180 S	70	64	62	61
180 M	73	64	62	61
200 M	73	66	63	59
200 L	74	66	-	-
225 M	74	68	63	63
250 S	75	69	65	61
250 M	75	69	65	61
280 S	78	72	68	65
280 M	78	72	68	65
315 S	79	76	70	65
315 M	79	76	68	66
315 L	79	76	68	66
315 LX	79	76	68	66

The noise values specified in the tables refer to operation at rated output, rated voltage and 50 Hz, with a tolerance of +3 dB.
Noise measurements in accordance with DIN EN ISO 1680

Explanations of modifications

Electrical/winding monitoring

Code	Modification	Description
101	Other voltage and/or frequency/special winding	Version for voltages or frequencies other than those specified by IEC/DIN or for special windings according to customer's request
102	Multi-voltage type (12 terminals)	Version for a multi-voltage motor in ratio 1:2 with $\Delta\Delta/\Delta$ circuit
335	Multi-voltage type 1:2 (9 terminals)	Version for a multi-voltage motor in ratio 1:2 with YY/Y circuit
103	1 x PT 100 (winding protection) four-wire circuit	One PT 100 temperature sensor of four-wire circuit type in the winding overhang of the drive side for protection of the winding
130	1 x PT 100 (winding protection) two-wire circuit	One PT 100 temperature sensor of two-wire circuit type in the winding overhang of the drive side for protection of the winding
379	1 x PT 100 (winding protection) two-wire circuit for converter-fed operation > 420 V (KU, KV, BM)	One PT 100 temperature sensor of two-wire circuit type in the winding overhang of the drive side for protection of the winding, suitable for converter-fed operation at voltages > 420 V
391	3 x PT 100 (winding protection) four-wire circuit	Three PT 100 temperature sensors of four-wire circuit type in each phase for the protection of the winding
392	3 x PT 100 (winding protection) two-wire circuit	Three PT 100 temperature sensors of two-wire circuit type in each phase for the protection of the winding
393	3 x PT 100 (winding protection) two-wire circuit for converter-fed operation > 420 V (KU, KV, BM)	Three PT 100 temperature sensors of two-wire circuit type in each phase for the protection of the winding, suitable for converter-fed operation at voltages > 420 V
480	1 x PT 1000 (winding protection) two-wire circuit	One PT 1000 temperature sensor of two-wire circuit type in the winding overhang of the drive side for protection of the winding
105	Y/ Δ start for one speed (9 terminals)	Modification for pole-changing motors with two windings
106	Y/ Δ start for two speeds (12 terminals)	Modification for pole-changing motors with two windings
128	3 PTC resistors	Three PTC resistor temperature sensors (PTC positive temperature coefficient), temperature-dependent semiconductor resistors with positive temperature coefficient, 1 sensor installed in each phase
371	3 PTC resistors for converter-fed operation > 420 V (KU, KV, BM)	as above, but special version for increased voltage loads in converter-fed operation
129	6 PTC resistors	Six PTC resistor temperature sensors, temperature-dependent semiconductor resistors with positive temperature coefficient, 1 sensor installed in each phase on each side of the motor
372	6 PTC resistors for converter-fed operation > 420 V (KU, KV, BM)	as above, but special version for increased voltage loads in converter-fed operation
87	Temperature sensor KTY 84-130 (1 pc.)	One temperature sensor on a semiconductor basis in the winding overhang of the drive side for protection of the winding
377	Temperature sensor KTY 84-130 (1 pc.) for converter-fed operation > 420 V (KU, KV, BM)	One temperature sensor on a semiconductor basis in the winding overhang of the drive side for protection of the winding, suitable for increased voltage loads in converter-fed operation
131	3 microtherm switches	One triple set of microtherm switches in the winding overhang of the drive side for protection of the winding
378	3 microtherm switches for converter-fed operation > 420 V (KU, KV, BM)	One triple set of microtherm switches in the winding overhang of the drive side for protection of the winding, suitable for increased voltage loads in converter-fed operation
388	6 microtherm switches	Two triple sets of microtherm switches in the winding overhang of the drive side for protection of the winding
389	6 microtherm switches for converter-fed operation > 420 V (KU, KV, BM)	Two triple sets of microtherm switches in the winding overhang of the drive side for protection of the winding, suitable for increased voltage loads in converter-fed operation

Note: Explanations of footnotes see page 1/56.

Code	Modification	Description
139	Anti-condensation heating/heating tape (110 V or 220 V, 50 Hz)	Version with anti-condensation heating or a heating tape for standard applications
336	Anti-condensation heating tape Ex 2G/2D (110V/220V)	Version with anti-condensation heating or a heating tape for explosion-protected motors
171	Thermal class 180 [H/F] (old: class H utilised to F)	Version in thermal class 180 with an insulation that is utilised to maximum TC 155
185	Thermal class 180 (old: class H)	Version in thermal class H according to F with insulation optimised for operation at increased temperatures
261	Version for voltages up to 1,000 V (mains operation)	Version for a motor operation on mains voltages > 725 V up to 1,000 V
444	K21R 56–132 T with special designation SP.2945	Version for converter-fed operation with max. load $\ddot{U} \leq 1,350 \text{ V}$ und $du/dt \leq 1 \text{ kV}/\mu\text{s}$
426	Converter-fed operation without filter up to 500 V	Version for converter-fed operation up to 500 V (curve A to EC TS 60034-26), so-called KU version with special insulation
366	Converter-fed operation without filter up to 690 V	Version for converter-fed operation up to 690 V (curve B to EC TS 60034-26), so-called KV version with special insulation
164	Generator version	Version for generator operation with a winding specially modified for this mode of operation
363	Auxiliary traction motor for converter operation (BMU)	Version for use as auxiliary traction motor (see below) for converter-fed operation
77	Auxiliary traction motor (BM) (incorporates TII and vibration-resistant design)	Version for use as auxiliary traction motor with the modifications TII and vibration-resistant design, as well as with special terminal leads and two-fold impregnation of the winding

Terminal connections/cable entry

Code	Modification	Description
97	Terminal box, side-mounted (right, left) Terminal box, inclined type	Version with terminal box mounted on side of motor, either right or left
98	Terminal box, rotated (entry D-end/N-end/left)	Version with terminal box mounted on top of the motor housing but rotated relative to the shaft axis
156	Terminal lead length greater than 1,000 mm (with 6 conductors each: for each 500 mm or part thereof) (for built-in motors only)	Supplement for terminal lead cable lengths exceeding 1,000 mm or, in the case of versions with six conductors, for each 500 mm or part thereof; applies to built-in motors only
158	Without terminal box, with cover plate	Version of motor without terminal box but with a cover plate fitted instead; the cable price is charged separately
159	Without terminal box, with cover box	Version of motor without terminal box but with a cover box fitted instead; the cable price is charged separately
337	Without terminal box, with cover box/flat connectors up to 1 m cable	Version of motor without terminal box but with a cover box fitted instead and additional flat connectors for the cables; the cable price is charged separately
187	Next larger terminal box	Version with the next larger terminal box fitted by customer request
188	Additional terminal box (without accessories)	Additional terminal box which is supplied without any accessories
196	Terminal box for auxiliary connections	Additional terminal box in which the auxiliary connections are accommodated
279	Terminal box in grey cast iron, 25/63 A	Terminal box made of grey cast iron with a standard connection face but larger cable cross-sections, suitable for 25 A or 63 A
289	VIK terminal box	Terminal box complying with the requirements of VIK Recommendation 1, Three-Phase Asynchronous Motors, Technical Requirements, 04.2005
302	1,000 A terminal box ¹⁾	Terminal box whose terminal board is suitable for a 1,000 A connection (busbars)
310	630 A terminal box ²⁾	Terminal box whose terminal board is suitable for a 630 A connection
168	Housing rotated in longitudinal direction	Y version, connections are located on fan side

Code	Modification	Description
357	Terminal box, N-end	Terminal box on N-end shield
441	IP 56 terminal box	Terminal box version in IP 56 to IEC/EN 60034-5 (EN 60529), IP 5x ... Protected against dust in harmful amounts, full protection against contact, IP x6 ... Protection against strong water jets
442	IP 65 terminal box	Terminal box version in IP 65 to IEC/EN 60034-5 (EN 60529), IP 6x ... Dust-tight, full protection against contact, IP x5 ... Protection against water jets (nozzle) from any angle
469	IP 66 terminal box	Terminal box version in IP 65 to IEC/EN 60034-5 (EN 60529), IP 6x ... Dust-tight, full protection against contact, IP x5 ... Protection against strong water jets





Types of protection/standards and regulations

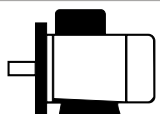

Code	Modification	Description
144	VEM power station design according to EW-N 8269 (KA)	Version with flexible terminal leads, climate-resistant rotor, terminal box dimensions according to VIK specifications, metallic cable glands and paint finish 02
314	VIK version	Version according to VIK Recommendation 1, Three-Phase Asynchronous Motors, Technical Requirements 03.2011
470	VIK Ex version	Version for explosion-protected motors according to VIK Recommendation 1, Three-Phase Asynchronous Motors, Technical Requirements 03.2011
374	Degree of protection IP 54	Degree of protection according to IEC/EN 60034-5: IP5x dust-proof, IPx4 splash water
125	Degree of protection IP 56	Degree of protection according to IEC/EN 60034-5: IP5x dust-proof, IPx6 strong water jets
85	Degree of protection IP 57 S	Degree of protection according to IEC/EN 60034-5: IP5x dust-proof, IPx7 S temporary immersion at standstill
170	Degree of protection IP 65	Degree of protection according to IEC/EN 60034-5: IP6x dust-tight, IPx5 water jets
169	Degree of protection IP 66	Degree of protection according to IEC/EN 60034-5: IP6x dust-tight, IPx6 strong water jets
137	Marine version IP 55	Marine version for below-deck operation, degree of protection IP 55, according to classification society ...
138	Marine version IP 56	Marine version for on-deck operation, degree of protection IP 56, according to classification society ...
307	Special marine version according to EW-N 8278 (mechanical)	Marine version according to works standard, without direct classification reference
361	Vertical design (marine version)	Special bearing concept with Q bearings for vertical types used in marine applications
382	Combined approval for USA, Canada (cULus)	Version meeting both the US regulations (UL 1004) and Canadian regulations (CSA C22.2.100)
387	Approval for USA (UL)	Version meeting the US regulations (UL 1004)
192	CSA version	Version meeting the Canadian regulations
194	NEMA version (electrical)	Version which meets the US regulations (NEMA-MG 1) with respect to the electrical properties
197	Rheinbraun standard EM 2.2	Version according to RB standard EM 2 (edition 04/99, Annex 1 of 04/99), EW-N 8231
252	Kali + Salz (E 5.09)	Version according to design standard E 5.09 of Kali + Salz AG, EW-N 8298
353	Version for port cranes according to EW-N 8233	Version according to EW-N 8233 with brake, cable entry on the right, welded fan cowl, climate-resistant rotor, special terminal board, two-fold impregnation (Joule heat and vacuum), paint system 04
191	Shell version (SH)	Version according to regulation DEP 33.66.05.31-Gen (edition February 2012), EW-N 8272
459	VEMoCHEM (VC)	Motor in chemical industry design, EW-N 8238 (includes VIK version)
471	Low-temperature version -45 °C, without shaft seals	Version in materials suitable for low temperatures to -45 °C, EW-N 8245

Note: Explanations of footnotes see page 1/56.

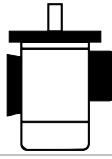
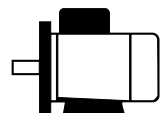
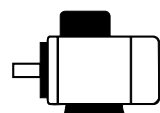
Code	Modification	Description
472	Low-temperature version -50 °C, without shaft seals	Version in materials suitable for low temperatures to -50 °C, EW-N 8245
473	Low-temperature version -60 °C, without shaft seals	Version in materials suitable for low temperatures to -60 °C, EW-N 8245

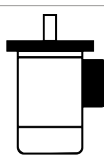
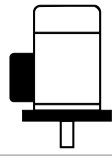
Types of construction

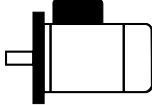
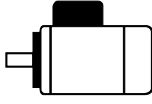
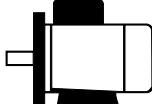
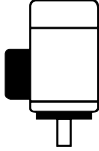
Code	Modification	Description
110	Without centring flange	Centring flange according to DIN EN 50347 not provided
375	Deviating flange according to catalogue	Flange assignment deviating from catalogue and DIN EN 50347
111	Version with welded feet (steel feet)	Steel feet instead of grey cast iron for the types IM B6, IM B7, IM B8, IM V5 ⁴⁾ , IM V6 ⁴⁾
369	Vertical version with Q bearings (required from 315 MY)	Special bearings to take up high axial forces; alternatively, a double bearing with two angular ball bearings may be used
112	IM B35	 Foot/flange design according to Code I, IEC/EN 60034-7, flange with through-holes [FF]
476	IM V15	 Foot/flange design according to Code I, IEC/EN 60034-7, flange with through-holes [FF], shaft end pointing down
476	IM V36	 Foot/flange design according to Code I, IEC/EN 60034-7, flange with through-holes [FF], shaft end pointing up
339	IM B35 K	 Foot/flange design according to Code I, IEC/EN 60034-7, smaller FF flange deviating from DIN EN 50347
113	IM B34	 Foot/flange design according to Code I, IEC/EN 60034-7, flange with threaded holes [FT]
114	IM B5	 Flange design according to Code I, IEC/EN 60034-7, flange with through-holes [FF]
362	IM V3	 Flange design according to Code I, IEC/EN 60034-7, flange with through-holes [FF], shaft end pointing down
356	IM V1	 Flange design according to Code I, IEC/EN 60034-7, flange with through-holes [FF], shaft end pointing up
117	Fan cowl with protective canopy	Version designed to prevent foreign objects falling into the fan of vertically mounted motors. The fan cowl is provided with a protective canopy larger in size than the circle of the air inlet openings.

Code	Modification	Description
338	IM B5 K	 <p>Flange design according to Code I, IEC/EN 60034-7, smaller FF flange deviating from DIN EN 50347</p>
115	IM B14, IM V18, IM V19	 <p>Flange design according to Code I, IEC/EN 60034-7, flange with threaded holes [FT]</p>
142	IM 2202 (IM B17, 2 nd shaft end included)	 <p>Flange on D- and N-ends of the motor; N-end flange designed as cast iron fan cowl</p>
352	Type B5 / furnace flange (standard dimension)/ aluminium fan	Special flange for furnace ventilation with integrated cooling wheel
288	PAD-mounted 8 foot holes under 45 deg	Motor without feet, mounted by way of threaded rods, threaded holes under 45 deg
475	IM V18	 <p>Flange design according to Code I, IEC/EN 60034-7, flange with threaded holes [FT], shaft end pointing down</p>
475	IM V19	 <p>Flange design according to Code I, IEC/EN 60034-7, flange with threaded holes [FT], shaft end pointing up</p>
481	Sheet-steel fan cowl	Sheet-steel fan cowl
330	Plastic fan cowl	Plastic fan cowl
428	Flange ring K21R, P(a1)=660/800	Flange assignment deviating from DIN, FF740 instead of FF600
429	Steel flange K22R 355, P(a1)=1000 mm	Flange in welded steel version, FF940

Note: Explanations of footnotes see page 1/56.

Mechanical modifications

Code	Modification	Description
107	Special shaft	Shorter, thicker or thinner shaft, deviating from catalogue, 2 nd shaft end included
108	Special shaft, 1 tapered shaft end	Special shaft with tapered shaft end, taper 1:10
427	Special shaft, 2 tapered shaft ends	Special shaft with two tapered shaft ends, taper 1:10
109	High-resistance rotor (Si 10)	High-resistance rotor
419	Shaft certificate (3.2)	Shaft certificate (3.2), required by some classification societies
116	Aluminium fan	Special fan in cast light-metal construction (EN AC-ALSiCu1Mg according to DIN EN 1706, material number EN AC 45300)
190	Grey cast iron fan	Special fan in grey cast iron construction (EN GJL-200 according to DIN EN 156 ¹)
195	Multi-wing fan (low-noise version)	Special low-noise unidirectional fan
330	Plastic fan cowl	Fan cover made of PC moulding compound, MR-09 B5 according to DIN 7744
333	Protective cover for encoder	Cover for protection of the incremental encoder
383	Vibration intensity B	Version with reduced vibration velocity in accordance with EN 60034-14
165	Balancing against zero	Precision balancing according to EW-N 8204 with very low vibration velocity
166	High-speed version (HS)	Version for motors which are intended for the use at speeds higher than those resulting from frequencies 50/60 Hz (e.g. converter-fed operation) and thus specially balanced
376	Balancing with full key	Version in which balancing is carried out with a full key instead of a half key
143	Type of cooling IC 418, non-ventilated version (K21R/K11R-O) (FAN)	Version of the motor without own fan in the cooling air flow
146	External earthing terminal on housing	Version with an additional external earthing terminal mounted on the housing
445	Type of cooling IC 410	Non-ventilated motor without own fan
161	Construction plant version (incl. TII, vibration-resistant)	Motors are vibration-resistant [see 163] and fitted with dust-proof bearings. Motors are always manufactured in combination with climate protection TII
162	Version for the textile industry	Version with a special ventilation system which reduces the accumulation of fibrous materials carried along by the cooling air, as well as IP 55, thermal class F according to B and thermal winding protection
163	Vibration-resistant version	Motors can be used under sinusoidal vibrations with a vibration load up to 4g at a frequency of 20 to 60 Hz. The winding overhang is specially stabilised for the anticipated load. The terminal leads are of flexible type and the screwed joints are locked by suitable means
177	Flange accuracy R according to DIN 42955	Version with reduced concentricity and axial eccentricity tolerance R according to DIN 42955
199	Condensate drain plug	Screw plug for closing the condensate drain hole
201	Condensate drain holes with felt plug (2 pcs.)	Hole at the lowest point of the housing or end shield (depending on type of motor) for draining the condensate accumulating in the motor interior, closed with a felt plug
280	Additional foot holes at the top of the housing	Foot holes are provided additionally at the top of the motor housing
285	Fan cowl with screen cut out	Version in which the screen is cut out from the fan cowl
294	Housing with load bracket thread (2 pcs.)	Version with two load bracket threads
322	Special fan	Fan deviating from standard design
331	Foot contact face, milled	Version in which foot contact faces are milled on the housing
411	Housing with ring nut (lifting eye)	Version with a ring nut
386	CRFID transponder (memory version)	Version equipped with an RFID transponder
463	Memory version retrofit kit (RFID transponder)	Retrofit kit for an RFID transponder
474	Earthing ring for bearing insulated on both sides	Earthing ring to prevent bearing currents

Corrosion protection/paint finish

Code	Modification	Description
133	Special paint colour	Colour specified by the customer
452	Special paint colours which are not available as paint system 01 (incl. paint system 02)	Colour specified by the customer
135	Paint system 02;02S "Worldwide" (open air, humid interior), corrosion class C2-C3 to EN ISO 12944-2:1998	Two-component EP primer and water-based top coat, layer thickness $\geq 110 \mu\text{m}$
354	Paint system 04 (marine/port climate)	Two-component EP ceramic-filled, layer thickness $\geq 150 \mu\text{m}$
368	Paint system 06 (heat, humidity, open air), corrosion class C2-C3 to EN ISO 12944-2:1998	Two-component EP primer and top coat, layer thickness $\geq 110 \mu\text{m}$
134	Paint system 07 (chemicals, heat, humidity, suitable for decontamination), corrosion class C3 to EN ISO 12944-2:1998	Double two-component EP primer and two-component EP top coat, layer thickness $\geq 150 \mu\text{m}$
443	Paint system 09L "Offshore" (UV-resistant), corrosion class C3 to EN ISO 12944-2:1998	Two-component EP water-based primer and two-component EP-PUR top coat, layer thickness $\geq 210 \mu\text{m}$
311	Paint system 09S "Offshore" (UV-resistant), corrosion class C4/5 to EN ISO 12944-2:1998	Two-component EP zinc-dust primer, and two-component EP intermediate coat (containing iron mica) and two-component EP-PUR top coat, layer thickness $\geq 240 \mu\text{m}$
460	Paint system 10L "Offshore", explosion-protection version (greater than $200 \mu\text{m}$)	General Ex version, layer thickness $\leq 200 \mu\text{m}$; outdoor installation, UV-resistant, high corrosion protection, corrosion class C3-C4 medium to high to EN ISO 12944-2:1998
461	Paint system 10S "Offshore", explosion-protection version (greater than $200 \mu\text{m}$)	General Ex version, layer thickness $\leq 200 \mu\text{m}$; offshore applications, drilling rigs, further enhanced corrosion protection, UV resistant, corrosion class C4/C5 high to very high (industry, marine) to EN ISO 12944-2:1998
136	Protection against enhanced climatic demands (TII)	Version with climate-resistant rotor, clamping bolts and standard parts with protective coating, stainless steel rating plate, paint system 02
412	Climate-resistant rotor	Rotor with a protective coating, suitable for tropical climates
173	Layer thicknesses per increase by $30 \mu\text{m}$	Supplement for paint layer thicknesses other than as specified for the VEM paint systems
200	External screws and bolts in stainless steel	All external screws and bolts made of stainless steel
286	Fan cowl or N-end bearing cover or N-end shield painted on inside	Supplement for an additional layer of anticorrosion protection on the fan cowl or N-end bearing cover or N-end shield
287	Fan spray-coated with epoxy resin varnish	Supplement for an epoxy resin varnish coating for the fan
351	Paint system acc. to special-drawing 3135	Paint system based on customer specifications and documented in special drawing 3135, usually with synthetic primer ($30 \mu\text{m}$) followed by paint coat as specified by the customer
315	Zinc-plated fan cowl	Supplement for zinc-plated fan cowl

Note: Explanations of footnotes see page 1/56.

Built-on components

Code	Modification	Description
96	Centric mounting of encoder (bell/intermediate flange, shaft end, coupling) (K21F, K21O)	Supplement for the centric mounting of an incremental encoder
99	Centric mounting by way of a flange end shield, N-end (IM 2202)	Supplement for the centric mounting of an incremental encoder by way of a flange end shield on the N-end
367	Centric mounting by way of combined mount	Supplement for motors of frame size 315 where an incremental encoder is to be mounted centrally
100	Mounting of tacho and incremental encoder (under fan cowl), plug-on version without equipment	Supplement for the mounting of tacho and incremental encoder under the fan cowl
418	Mounting for Harting connector/switch	Connector system from Harting, socket (without plug)/switch
150	Mounting for backstop (without lock)	Supplement for the mounting of a backstop
358	Brake mounting	Supplement for the mounting of a motor brake
479	External fan mounting	Supplement for the mounting of an external fan
465	Gearbox mounting	Supplement for the mounting of a gearbox

Bearings

Code	Modification	Description
95	Oil-tight design (radial shaft seal, N-end fixed bearing)	Supplement for oil-tight design with radial shaft seal and fixed bearing on N-end
118	Radial sealing ring, D-end (incl. N-end fixed bearing)	Supplement for fitting of a radial sealing ring on the D-end, including a fixed bearing on the N-end
119	Fixed bearing, D-end	Supplement for a fixed bearing on the D-end
390	Fixed bearing, D-end, play-free	Supplement for a play-free fixed bearing on the D-end
120	Fixed bearing, N-end	Supplement for a fixed bearing on the N-end
121	Angular ball bearing, D-end	Supplement for an angular ball bearing on the D-end
122	Increased transverse forces, D-end (fixed bearing at N-end included)	Supplement for a motor design taking into account increased transverse forces on the D-end, including a fixed bearing on the N-end
415	Insulated roller bearing	Supplement for the fitting of an insulated roller bearing
340	Reinforced bearing, D-end (fixed bearing series 42.. included)	Supplement for a reinforced bearing on the D-end, including a fixed bearing from series 42..
332	Labyrinth seal	Supplement for the fitting of a labyrinth seal
342	Bearing sealing with combined seal, D-end	Supplement for the fitting of a combined seal for sealing of the bearing on the D-end
151	Bearing monitoring with temperature sensor for each bearing point (D-end/N-end) (without additional terminal box)	Supplement for the fitting of a temperature sensor for bearing monitoring for each bearing point, without requiring an additional terminal box
153	Bearing monitoring with PT 100 (2 conductors) for each bearing point	Supplement for the fitting of a bearing temperature monitoring facility with one PT 100 in two-wire circuit design for each bearing point
154	Bearing monitoring with PT 100 (4 conductors) for each bearing point	Supplement for the fitting of a bearing temperature monitoring facility with one PT 100 in four-wire circuit design for each bearing point
193	Relubricating device ^{6) 8)}	Version with relubricating device
262	Insulated bearing, N-end	Fitting of an insulated bearing on the N-end
413	Insulated bearing, D-end	Fitting of an insulated bearing on the D-end
278	Flat lubricating nipple in stainless steel (for both ends)	Fitting of a flat lubricating nipple on the D- and N-ends
394	Tapered lubricating nipple (for both ends)	Fitting of a tapered lubricating nipple on the D- and N-ends
321	Tapered lubricating nipple of stainless steel (for both ends)	Fitting of a stainless steel tapered lubricating nipple on the D- and N-ends
283	Fixed SPM sensor with accessories (for each bearing point)	Fitting of a fixed SPM sensor with accessories for each bearing point
284	SPM prepared without nipple	Motor is prepared for the installation of an SPM sensor
152	SPM bearing monitoring with nipple (2 pieces)	Fitting of a bearing monitoring facility with SPM sensor
434	SPM bearing monitoring with stainless steel nipple (2 pieces)	Fitting of a bearing monitoring facility with SPM sensor

Code	Modification	Description
467	Fixed SPM sensor with accessories (for each bearing point)	Fitting of a bearing monitoring facility with SPM sensor
306	Bearing sealing with radial shaft seal 9RB	Supplement for bearing sealing with a radial shaft seal 9RB
323	Double bearing seal, D-end (2 radial shaft seals + grease chamber) ⁷⁾	Supplement for a double bearing seal on the D-end, with 2 radial shaft seals and grease chamber
364	Axial shaft seal	Supplement for the fitting of an axial shaft seal
365	Gamma ring	Supplement for the fitting of a gamma ring
127	Special grease	Supplement for the use of a special grease

Miscellaneous

Code	Modification	Description
147	Second rating plate, loose	Supplement for provision of a second rating plate, enclosed as loose item
148	Customer rating plate	Supplement for the creation of a rating plate according to customer specifications
414	Position plate	Supplement for the mounting of a position plate
149	Stainless steel rating plate	Supplement for a stainless steel rating plate
253	Silicone-free design	Supplement for a motor design free of silicone
410	Handling costs for supplied items	Supplement to cover the costs of handling tools/equipment supplied by the customer
431	Coolant temperature ≥ 100 °C	Version for coolant temperatures ≥ 100 °C

Note: Explanations of footnotes see page 1/56.

Overview of modifications

IEC/DIN (IE1-)K21. (IE2-)WE1./WE2./W21. (IE3-)W41./W42.	Price- Code Transform (IE1-)K20. (IE2-)WE0./W20. Chapter	Standard motors	Pole-switching motors	Transform motors	Motors for converter-fed operation	Water-cooled motors	Slip-ring motors	Built-in motors	Fire-gas motors	Roller table motors, light-duty series	Roller table motors, ARB	Roller table motors, AFC	Roller table motors, DS..	Type of protection "eb" - Increased safety	Type of protection "d/de" - Flameproof enclosure	Type of protection "ec" - Increased safety	Protection by enclosure "fb", Zone 21	Protection by enclosure "fc", Zone 22	Motors for marine operation	Permanent magnet synchronous motors	Asynchronous generators
		2	2	3	4	5	6	7	8	9	9	9	9	10	10	10	10	10	11	12	13
Efficiency class acc. to IEC/EN 60034-30-1																					
	without classification	•	•	-	•	•	•	•	•	•	•	•	•	•	•	•	•	•	•	•	•
	Standard Efficiency IE1	•	-	-	•	-	-	•	•	•	-	-	-	•	-	-	-	-	•	-	-
	High Efficiency IE2	•	-	•	•	•	-	•	•	•	-	-	-	•	•	•	•	•	•	-	-
	Premium Efficiency IE3	•	-	•	•	•	-	•	•	•	-	-	-	•	•	•	•	•	•	-	-
	Super Premium Efficiency IE4	•	-	•	-	•	-	-	-	-	-	-	-	•	-	•	•	•	-	•	-
Electrical/Winding monitoring																					
	101 different voltage and/or frequency/special winding	•	•	•	•	•	•	•	•	•	•	•	•	•	•	•	•	•	•	•	•
	102 voltage-changeable (12 terminals)	•	-	•	•	•	•	•	•	•	•	•	•	-	-	-	-	-	•	-	-
	335 voltage-changeable 1:2 (9 terminals)	•	•	•	•	•	•	•	•	•	•	•	•	-	•	-	-	-	•	-	-
	103 1 x PT 100 (winding protection) 4-wires-connection	•	•	•	•	•	•	•	•	•	•	•	•	•	•	•	•	•	•	•	•
	130 1 x PT 100 (winding protection) 2-wires-connection	•	•	•	•	•	•	•	•	•	•	•	•	•	•	•	•	•	•	•	•
	379 1 x PT 100 (winding protection) 2-wires-connection for converter feeding > 420 V (KU, KV, BM)	•	•	•	•	•	•	•	•	•	•	•	•	•	•	•	•	•	•	•	•
	391 3 x PT 100 (winding protection) 4-wires-connection	•	•	•	•	•	•	•	•	•	•	•	•	•	•	•	•	•	•	•	•
	392 3 x PT 100 (winding protection) 2-wires-connection	•	•	•	•	•	•	•	•	•	•	•	•	•	•	•	•	•	•	•	•
	393 3 x PT 100 (winding protection) 2-wires-connection for converter feeding > 420 V (KU, KV, BM)	•	•	•	•	•	•	•	•	•	•	•	•	•	•	•	•	•	•	•	•
	480 1 x PT 1000 (winding protection) two-wire circuit	•	•	•	•	•	•	•	•	•	•	•	•	•	•	•	•	•	•	•	•
	105 star/delta starting for 1 speed (9 terminals)	-	•	-	-	-	-	-	-	-	-	-	-	-	-	-	-	-	-	-	-
	106 star/delta starting for 2 speeds (12 terminals)	-	•	-	-	-	-	-	-	-	-	-	-	-	-	-	-	-	-	-	-
	128 3 PTC	•	•	•	•	•	•	•	•	•	•	•	•	•	•	•	•	•	•	•	•
	371 3 PTC for converter feeding > 420 V (KU, KV, BM)	•	•	•	•	•	•	•	•	•	•	•	•	•	•	•	•	•	•	•	•
	129 6 PTC	•	•	•	•	•	•	•	•	•	•	•	•	•	•	•	•	•	•	•	•
	372 6 PTC for converter feeding > 420 V (KU, KV, BM)	•	•	•	•	•	•	•	•	•	•	•	•	•	•	•	•	•	•	•	•
	87 temperature sensor KTY 84-130 (1 pc.)	•	•	•	•	•	•	•	•	•	•	•	•	•	•	•	•	•	•	•	•
	377 temperature sensor KTY 84-130 (1 pc.) for converter feeding > 420 V (KU, KV, BM)	•	•	•	•	•	•	•	•	•	•	•	•	•	•	•	•	•	•	•	•
	131 3 Microtherm switches	•	•	•	•	•	•	•	•	•	•	•	•	-	•	-	•	•	•	•	•
	378 3 Microtherm switches for converter feeding > 420 V (KU, KV, BM)	•	•	•	•	•	•	•	•	•	•	•	•	-	•	-	•	•	•	•	•
	388 6 Microtherm switches	•	•	•	•	•	•	•	•	•	•	•	•	-	•	-	•	•	•	•	•
	389 6 Microtherm switches for converter feeding > 420 V (KU, KV, BM)	•	•	•	•	•	•	•	•	•	•	•	•	-	•	-	•	•	•	•	•
	139 anti-condensation heating/heating tape (110 V or 220 V, 50 Hz)	•	•	•	•	•	•	•	•	•	•	•	•	-	-	-	-	-	•	•	•
	336 anti-condensations heating Ex 2G/2D (110 V/220 V)	-	-	-	-	-	-	-	-	-	-	-	-	-	-	-	-	-	-	-	-
	171 insulation class H (cold) (used acc. to F)	•	•	•	•	•	•	•	•	•	•	•	•	•	•	•	•	•	•	•	•
	185 insulation class H (hot), insulation class H	•	•	•	•	•	•	•	•	•	•	•	•	-	-	-	-	-	•	•	•
	261 insulation for voltages 1000 V (mains operation)	•	•	•	•	•	•	•	•	•	•	•	•	-	•	-	•	•	•	•	•
	444 K21R 56-132 T with special mark SP.2945, Ü ≤1.350 V and du/dt ≤1kV/mys	•	-	-	-	-	-	-	-	-	-	-	-	-	-	-	-	-	-	-	-
	426 Inverter operation without filter up to 500 V, curve A acc. to IEC TS 60034-25	•	-	•	•	•	-	•	•	•	•	•	•	•	•	•	•	•	•	•	•
	366 Inverter operation without filter up to 690 V, curve B acc. to IEC TS 60034-26	•	•	•	•	•	•	•	•	•	•	•	•	-	•	•	•	•	•	•	•
	293 insulation class F/B special sheet steel	•	•	•	•	•	•	•	•	•	•	•	•	-	-	-	-	-	•	•	•
	164 version as a generator	-	-	-	-	-	-	-	-	-	-	-	-	-	-	-	-	-	-	•	•
	363 auxiliary railway motor converter feeding (BMU)	•	•	-	•	•	•	•	•	•	•	•	•	-	-	-	-	-	•	-	-
	77 auxiliary railway motor (BM) (include TII+vibration-proof version)	•	•	-	•	•	•	-	•	•	•	•	•	-	-	-	-	-	•	-	-

		IEC/DIN													Price-											
		(IE1-)K21.													Code											
		(IE2-)WE1./WE2./W21.													(IE1-)K20.											
		(IE3-)W41./W42.													(IE2-)WE0./W20.											
		Chapter																								
56	63	71	80	90	100	100 LX, 112	132 T	132	160	180	200	225	250	280	315 S-MX	315 MY	315 L, LX	355 MY, M	355 MX, LY, L	400	450	500	560	630		
.	56	63	71	80	90	100		112	132	160	180	200	225	250	280	315 S-MX	315 L, LX	
Efficiency class acc. to IEC/EN 60034-30-1																										
X	X	X	X	X	X	X	X	X	X	X	X	X	X	X	X	X	X	X	X	X	X	X	X	X	X	
without classification																										
X	X	X	X	X	X	X	X	X	X	X	X	X	X	X	X	X	X	X	X	X	X	X	X	X	X	
Standard Efficiency IE1																										
X	X	X	X	X	X	X	X	X	X	X	X	X	X	X	X	X	X	X	X	X	X	X	X	X	X	
High Efficiency IE2																										
X	X	X	X	X	X	X	X	X	X	X	X	X	X	X	X	X	X	X	X	X	X	X	X	X	X	
Premium Efficiency IE3																										
-	-	-	-	X	X	X	X	X	X	X	X	X	X	X	X	X	X	X	X	X	X	X	X	X	X	
Super Premium Efficiency IE4																										
Electrical/Winding monitoring																										
X	X	X	X	X	X	X	X	X	X	X	X	X	X	X	X	X	X	X	X	X	X	X	X	X	X	
different voltage and/or frequency/special winding																										
A	X	X	X	X	X	X	X	X	X	X	X	X	X	X	X	X	X	X	X	X	X	X	X	X	X	
voltage-changeable (12 terminals)																										
-	X	X	X	X	X	X	X	-	-	-	-	-	-	-	-	-	-	-	-	-	-	-	-	-	-	
voltage-changeable 1:2 (9 terminals)																										
X	X	X	X	X	X	X	X	X	X	X	X	X	X	X	X	X	X	X	X	X	X	X	X	X	X	
1 x PT 100 (winding protection) 4-wires-connection																										
X	X	X	X	X	X	X	X	X	X	X	X	X	X	X	X	X	X	X	X	X	X	X	X	X	X	
1 x PT 100 (winding protection) 2-wires-connection																										
-	-	-	-	-	-	-	X	X	X	X	X	X	X	X	X	X	X	X	X	X	X	X	X	X	X	
1 x PT 100 (winding protection) 2-wires-connection for converter feeding > 420 V (KU, KV, BM)																										
A	A	A	A	A	A	A	A	X	X	X	X	X	X	X	X	X	X	X	X	X	X	X	X	X	X	
3 x PT 100 (winding protection) 4-wires-connection																										
A	A	A	A	A	A	A	A	X	X	X	X	X	X	X	X	X	X	X	X	X	X	X	X	X	X	
3 x PT 100 (winding protection) 2-wires-connection																										
-	-	-	-	-	-	-	X	X	X	X	X	X	X	X	X	X	X	X	X	X	X	X	X	X	X	
3 x PT 100 (winding protection) 2-wires-connection for converter feeding > 420 V (KU, KV, BM)																										
-	-	-	-	-	-	-	X	X	X	X	X	X	X	X	X	X	X	X	X	X	X	X	X	X	X	
1 x PT 1000 (winding protection) two-wire circuit																										
-	-	-	-	-	-	-	X	X	X	X	X	X	X	X	X	X	X	X	X	X	X	X	X	X	X	
star/delta starting for 1 speed (9 terminals)																										
-	-	-	X	X	X	X	X	X	X	X	X	X	X	X	X	X	X	X	X	X	X	X	X	X	X	
star/delta starting for 2 speeds (12 terminals)																										
X	X	X	X	X	X	X	X	X	X	X	X	X	X	X	X	X	X	X	X	X	X	X	X	X	X	
3 PTC																										
X	X	X	X	X	X	X	X	X	X	X	X	X	X	X	X	X	X	X	X	X	X	X	X	X	X	
3 PTC for converter feeding > 420 V (KU, KV, BM)																										
X	X	X	X	X	X	X	X	X	X	X	X	X	X	X	X	X	X	X	X	X	X	X	X	X	X	
6 PTC																										
X	X	X	X	X	X	X	X	X	X	X	X	X	X	X	X	X	X	X	X	X	X	X	X	X	X	
6 PTC for converter feeding > 420 V (KU, KV, BM)																										
X	X	X	X	X	X	X	X	X	X	X	X	X	X	X	X	X	X	X	X	X	X	X	X	X	X	
temperature sensor KTY 84-130 (1 pc.)																										
-	-	-	-	-	-	-	X	X	X	X	X	X	X	X	X	X	X	X	X	X	X	X	X	X	X	
temperature sensor KTY 84-130 (1 pc.) for converter feeding > 420 V (KU, KV, BM)																										
X	X	X	X	X	X	X	X	X	X	X	X	X	X	X	X	X	X	X	X	X	X	X	X	X	X	
3 Microtherm switches																										
-	-	-	-	-	-	-	X	X	X	X	X	X	X	X	X	X	X	X	X	X	X	X	X	X	X	
3 Microtherm switches for converter feeding > 420 V (KU, KV, BM)																										
X	X	X	X	X	X	X	X	X	X	X	X	X	X	X	X	X	X	X	X	X	X	X	X	X	X	
6 Microtherm switches																										
-	-	-	-	-	-	-	X	X	X	X	X	X	X	X	X	X	X	X	X	X	X	X	X	X	X	
6 Microtherm switches for converter feeding > 420 V (KU, KV, BM)																										
X	X	X	X	X	X	X	X	X	X	X	X	X	X	X	X	X	X	X	X	X	X	X	X	X	X	
anti-condensation heating/heating tape (110 V or 220 V, 50 Hz)																										
X	X	X	X	X	X	X	X	X	X	X	X	X	X	X	X	X	X	X	X	X	X	X	X	X	X	
anti-condensations heating Ex 2G/2D (110 V/220 V)																										
-	-	-	-	-	-	-	X	X	X	X	X	X	X	X	X	X	X	X	X	X	X	X	X	X	X	
insulation class H (cold) (used acc. to F)																										
X	X	X	X	X	X	X	X	X	X	X	X	X	X	X	X	X	X	X	X	X	X	X	X	X	X	
insulation class H (hot), insulation class H																										
-	-	A	A	A	A	A	A	X	X	X	X	X	X	X	X	X	X	X	X	X	X	X	X	X	X	
insulation for voltages 1000 V (mains operation)																										
X	X	X	X	X	X	X	X	-	-	-	-	-	-	-	-	-	-	-	-	-	-	-	-	-	-	
K21R 56-132 T with special mark SP.2945, U ≤ 1.350 V and du/dt ≤ 1kV/mys																										
X	X	X	X	X	X	X	X	X	X	X	X	X	X	X	X	X	X	X	X	X	X	X	X	X	X	
Inverter operation without filter up to 500 V, curve A acc. to IEC TS 60034-25																										
-	-	-	-	-	-	-	X	X	X	X	X	X	X	X	X	X	X	X	X	X	X	X	X	X	X	
Inverter operation without filter up to 690 V, curve B acc. to IEC TS 60034-26																										
-	-	-	-	-	-	-	X	X	X	X	X	X	X	X	X	X	X	X	X	X	X	X	X	X	X	
insulation class F/B special sheet steel																										
-	-	-	-	-	-	-	X	X	X	X	X	X	X	X	X	X	X	X	X	X	X	X	X	X	X	
version as a generator																										
X	X	X	X	X	X	X	A	X	X	X	X	X	X	X	X	X	X	X	X	X	X	X	X	X	X	
auxiliary railway motor converter feeding (BMU)																										
X	X	X	X	X	X	X	A	X	X	X	X	X	X	X	X	X	X	X	X	X	X	X	X	X	X	
auxiliary railway motor (BM) (include TII+vibration-proof version)																										

Price-Code	Transnorm (IE1-)K20. (IE2-)WE0./W20. Chapter	Standard motors	Pole-switching motors	Transnorm motors	Motors for converter-fed operation	Water-cooled motors	Slip-ring motors	Built-in motors	Fire-gas motors	Roller table motors, light-duty series	Roller table motors, ARB	Roller table motors, AFC	Roller table motors, DS..	Type of protection "eb" - Increased safety	Type of protection "d/de" - Flameproof enclosure	Type of protection "ec" - Increased safety	Protection by enclosure "tb", Zone 21	Protection by enclosure "tc", Zone 22	Motors for marine operation	Permanent magnet synchronous motors	Asynchronous generators
Connection system/cable entry																					
97	terminal box right, left hand side	•	•	•	•	•	•	-	•	•	•	•	•	•	•	•	•	•	•	•	•
	terminal box sloping version	-	-	•	•	•	•	-	•	•	•	•	•	•	•	•	•	•	•	•	•
98	terminal box turned (gland towards D-/N-end/left-hand side)	•	•	•	•	•	•	-	•	•	•	•	•	•	•	•	•	•	•	•	•
156	lead length larger than 1000 mm (for 6 wires, for each started-on 500 mm) (only for built-in motors)	•	•	•	•	•	•	-	•	•	•	•	•	-	-	-	-	-	•	•	•
158	without terminal box, with cover plate (without cable price)	•	•	•	•	•	•	-	•	•	•	•	•	-	-	•	-	•	•	•	•
159	without terminal box, with cover box (without cable price)	•	•	•	•	•	•	-	•	•	•	•	•	-	-	•	-	•	•	•	•
337	without terminal box, with cover box/flat connection system for max. 1m cable	•	•	•	•	•	•	-	•	•	•	•	•	-	-	•	-	•	•	•	•
187	terminal box next larger size	•	•	•	•	•	•	-	•	•	•	•	•	•	•	•	•	•	•	•	•
188	additional terminal box (without accessories)	•	•	•	•	•	•	-	•	•	•	•	•	•	•	•	•	•	•	•	•
196	terminal box for auxiliary contacts	•	•	•	•	•	•	-	•	•	•	•	•	•	•	•	•	•	•	•	•
279	terminal box grey cast-iron 25/63 A	•	•	•	•	•	•	-	•	•	•	•	•	•	•	•	•	•	•	•	•
279	VIK terminal box	•	•	-	•	-	-	-	•	•	•	•	-	•	•	•	•	•	•	•	•
289	1000 A terminal box	•	•	•	•	•	•	-	•	•	•	•	•	•	•	•	•	•	•	•	•
310	630 A terminal box	-	-	•	•	-	-	-	•	•	•	•	•	•	•	•	•	•	•	•	•
302	housing rotated in longitudinal direction	-	-	•	•	-	-	-	•	•	•	•	•	•	•	•	•	•	•	•	•
168	terminal box N-end	•	•	-	•	•	-	•	•	•	•	•	•	•	•	•	•	•	•	•	•
357	KK N-Seite	•	•	•	•	•	•	-	•	•	•	•	•	-	•	•	•	•	•	•	•
441	terminal box IP 56	•	•	•	•	•	•	-	•	•	•	•	•	•	•	•	•	•	•	•	•
442	terminal box IP 65	•	•	•	•	•	•	-	•	•	•	•	•	•	•	•	•	•	•	•	•
469	terminal box IP 66	•	•	•	•	•	•	-	•	•	•	•	•	•	•	•	•	•	•	•	•
Types of protection/Standards and regulations																					
144	VEM version for power plans acc. to EW-N 8269 (KA)	•	•	•	•	•	•	-	•	•	•	•	•	•	•	•	•	•	•	•	•
314	VIK version	•	•	•	•	•	•	-	•	•	•	•	•	-	-	-	-	-	•	•	•
470	Ex VIK version	-	-	-	-	-	-	-	-	-	-	-	-	-	-	-	-	-	•	-	-
374	Degree of protection IP 54	•	•	•	•	•	•	-	•	•	•	•	•	•	•	•	•	•	•	•	•
125	Degree of protection IP 56	•	•	•	•	•	•	-	•	•	•	•	•	•	•	•	•	•	•	•	•
85	IP 57 S	•	•	•	•	•	•	-	•	•	•	•	•	•	•	•	•	•	•	•	•
170	Degree of protection IP 65	•	•	•	•	•	•	-	•	•	•	•	•	•	•	•	•	•	•	•	•
169	Degree of protection IP 66	•	•	•	•	•	•	-	•	•	•	•	•	•	•	•	•	•	•	•	•
137	marine version IP 55	•	•	•	•	•	•	-	•	•	•	•	•	•	•	•	•	•	•	•	•
138	marine version IP 56	•	•	•	•	•	•	-	•	•	•	•	•	•	•	•	•	•	•	•	•
307	special marine version acc. to EWN 8278 (mechanical)	•	•	•	•	•	•	-	•	•	•	•	•	•	•	•	•	•	•	•	•
361	vertical design (in case of ship)	•	•	•	•	•	•	-	•	•	•	•	•	•	•	•	•	•	•	•	•
382	combined approval for USA, Canada (c UL us)	•	•	•	•	•	•	-	•	•	•	•	•	•	-	-	-	-	•	•	•
387	Approval for USA (UL)	•	•	•	•	•	•	-	•	•	•	•	•	•	-	-	-	-	•	-	-
192	CSA version	•	•	•	•	•	•	-	•	•	•	•	•	•	-	-	-	-	•	-	-
194	NEMA version (electrically)	•	•	•	•	•	•	-	•	•	•	•	•	•	-	-	-	-	•	•	•
197	Rheinbraun standard EM 2.2	•	•	•	•	•	•	-	•	•	•	•	•	•	-	-	-	-	•	•	•
252	Kali + Satz (E 5.09)	•	•	•	•	•	•	-	•	•	•	•	•	•	-	-	-	-	•	•	•
353	Version for harbour cranes according to EW-N 8233	•	•	•	•	•	•	-	•	•	•	•	•	•	-	-	-	-	•	•	•
191	Shell-design (SH)	•	•	•	•	•	•	-	•	•	•	•	•	•	•	•	•	•	•	•	•
459	VEMoCHEM (VC)	•	•	•	•	•	•	-	•	•	•	•	•	•	•	•	•	•	•	•	•
471	Design for low temperature application -45 °C without shaft seals	•	•	•	•	•	•	-	•	•	•	•	•	•	-	-	-	-	-	-	•
472	Design for low temperature application -50 °C without shaft seals	•	•	•	•	•	•	-	•	•	•	•	•	•	•	-	-	-	-	-	•
473	Design for low temperature application -60 °C without shaft seals	•	•	•	•	•	•	-	•	•	•	•	•	•	•	-	-	-	-	-	•

																IEC/DIN											
																(IE1-)K21.											
																(IE2-)WE1./WE2./W21.											
																(IE3-)W41./W42.											
56	63	71	80	90	100	100 LX, 112	132 T	132	160	180	180	200	225	250	280	315 S-MX	315 MY	315 L, LX	355 MY, M	355 MX, LY, L	400	450	500	560	630	Price- Transm Code (IE1-)K20. (IE2-)WE0./W20. Chapter	
.	56	63	71	80	90	100		112	132	160	180	200	225	250	280	315 S-MX	315 MY	315 L, LX		
Connection system/cable entry																											
X	X	X	X	X	X	X	X	X	X	X	X	X	X	X	X	X	X	X	X	K	K	K	X	X	X	terminal box right, left hand side	97
K	K	K	K	K	K	K	K	K	K	K	K	K	K	K	K	K	K	K	O	O	O	O	K	K	K	terminal box sloping version	
X	X	X	X	X	X	X	X	X	X	X	X	X	X	X	X	X	X	X	A	A	A	A	A	A	A	terminal box turned (gland towards D-/N-end/left-hand side)	98
X	X	X	X	X	X	X	X	X	X	X	X	X	X	X	X	X	X	X	X	X	X	-	-	-	-	lead length larger than 1000 mm (for 6 wires, for each started-on 500 mm) (only for built-in motors)	156
-	-	-	-	-	-	-	-	X	X	X	X	X	X	X	X	X	X	A	K	K	K	K	K	K	K	without terminal box, with cover plate (without cable price)	158
X	X	X	X	X	X	X	X	X	X	X	X	X	X	X	X	X	X	A	A	A	A	A	A	A	A	without terminal box, with cover box (without cable price)	159
X	X	X	X	X	X	X	X	-	-	-	-	-	-	-	-	-	-	-	-	-	-	-	-	-	-	without terminal box, with cover box/flat connection system for max. 1m cable	337
X	X	X	X	X	X	X	X	X	X	X	X	X	X	X	X	X	X	X	X	K	K	K	K	K	K	terminal box next larger size	187
X	X	X	X	X	X	X	X	X	X	X	X	X	X	X	X	X	X	X	X	X	X	X	X	X	X	additional terminal box (without accessories)	188
-	-	-	-	-	-	-	-	X	X	X	X	X	X	X	X	X	X	X	X	X	X	X	X	X	X	terminal box for auxiliary contacts	196
X	X	X	X	X	X	X	X	X	X	X	X	X	X	X	X	X	X	X	X	X	X	X	X	X	X	terminal box grey cast-iron 25/63 A	279
-	-	-	-	-	-	-	-	X	X	-	-	-	-	-	-	-	-	-	-	-	-	-	-	-	-	VIK terminal box	279
-	-	-	-	-	-	-	-	X	X	X	X	X	X	X	X	X	X	X	X	X	X	X	X	X	X	1000 A terminal box	289
-	-	-	-	-	-	-	-	-	-	-	-	-	-	-	-	X	X	N	N	O	-	-	-	-	-	630 A terminal box	310
-	-	-	-	-	-	-	-	-	-	-	-	-	-	-	-	X	X	X	N	N	-	-	-	-	-	housing rotated in longitudinal direction	302
K	K	K	K	K	K	K	K	X	X	X	X	X	X	X	X	X	X	X	X	K	K	K	X	X	X	terminal box N-end	168
X	X	X	X	X	X	X	X	K	K	K	K	K	K	K	K	K	K	K	K	K	K	K	X	X	X	KK N-Seite	357
X	X	X	X	X	X	X	X	X	X	X	X	X	X	X	X	X	X	X	X	X	X	X	X	X	X	terminal box IP 56	441
X	X	X	X	X	X	X	X	X	X	X	X	X	X	X	X	X	X	X	X	X	X	X	X	X	X	terminal box IP 65	442
X	X	X	X	X	X	X	X	X	X	X	X	X	X	X	X	X	X	X	X	X	X	X	X	X	X	terminal box IP 66	469
Types of protection/Standards and regulations																											
X	X	X	X	X	X	X	X	X	X	X	X	X	X	X	X	X	X	X	X	X	X	X	X	X	X	VEM version for power plans acc. to EW-N 8269 (KA)	144
X	X	X	X	X	X	X	X	X	X	X	X	X	X	X	X	X	X	X	X	X	X	X	X	X	X	VIK version	314
X	X	X	X	X	X	X	X	X	X	X	X	X	X	X	X	X	X	X	X	X	X	X	X	X	X	Ex VIK version	470
-	-	-	-	-	-	-	-	X	X	X	X	X	X	X	X	X	X	X	X	X	X	X	X	X	X	Degree of protection IP 54	374
X	X	X	X	X	X	X	X	X	X	X	X	X	X	X	X	X	X	X	X	X	X	X	X	X	X	Degree of protection IP 56	125
-	-	-	-	-	-	-	-	X	X	X	X	X	X	X	X	X	X	X	X	X	X	X	X	X	X	IP 57 S	85
X	X	X	X	X	X	X	X	X	X	X	X	X	X	X	X	X	X	X	X	X	X	X	X	X	X	Degree of protection IP 65	170
X	X	X	X	X	X	X	X	X	X	X	X	X	X	X	X	X	X	X	X	X	X	X	X	X	X	Degree of protection IP 66	169
-	-	-	-	-	-	-	-	X	X	X	X	X	X	X	X	X	X	X	X	X	X	X	X	X	X	marine version IP 55	137
-	-	-	-	-	-	-	-	X	X	X	X	X	X	X	X	X	X	X	X	X	X	X	X	X	X	marine version IP 56	138
-	-	-	-	-	-	-	-	X	X	X	X	X	X	X	X	X	X	X	X	X	X	X	X	X	X	special marine version acc. to EWN 8278 (mechanical)	307
-	-	-	-	-	-	-	-	-	-	-	-	X	X	X	X	X	X	X	X	X	X	X	X	X	X	vertical design (in case of ship)	361
X	X	X	X	X	X	X	X	X	X	X	X	X	X	X	X	X	X	X	X	X	X	-	-	-	-	combined approval for USA, Canada (c UL us)	382
X	X	X	X	X	X	X	X	X	X	X	X	X	X	X	X	X	X	X	X	X	X	-	-	-	-	Approval for USA (UL)	387
-	-	-	-	-	-	-	-	X	X	X	X	X	X	X	X	X	X	-	-	-	-	-	-	-	-	CSA version	192
X	X	X	X	X	X	X	X	X	X	X	X	X	X	X	X	X	X	X	X	X	X	X	X	X	X	NEMA version (electrically)	194
-	-	-	-	-	-	-	-	X	X	X	X	X	X	X	X	X	X	X	X	X	X	X	X	X	X	Rheinbraun standard EM 2.2	197
-	-	-	-	-	-	-	-	X	X	X	X	X	X	X	X	X	X	X	X	X	X	X	X	X	X	Kali + Salz (E 5.09)	252
-	-	-	-	-	-	-	-	X	X	X	X	X	X	X	X	X	A	A	A	A	A	A	A	A	A	Version for harbour cranes according to EW-N 8233	353
-	-	-	-	-	-	-	-	X	X	X	X	X	X	X	X	X	X	X	X	X	X	-	-	-	-	Shell-design (SH)	191
-	-	-	-	-	-	-	-	X	X	X	X	X	X	X	X	X	X	X	X	X	X	-	-	-	-	VEMoCHEM (VC)	459
X	X	X	X	X	X	X	X	X	X	X	X	X	X	X	X	X	X	X	X	X	X	X	X	X	X	Design for low temperature application -45 °C without shaft seals	471
X	X	X	X	X	X	X	X	X	X	X	X	X	X	X	X	X	X	X	X	X	X	X	X	X	X	Design for low temperature application -50 °C without shaft seals	472
X	X	X	X	X	X	X	X	X	X	X	X	X	X	X	X	X	X	X	X	X	X	X	X	X	X	Design for low temperature application -60 °C without shaft seals	473

IEC/DIN (IE1-)K21. (IE2-)WE1./WE2./W21. (IE3-)W41./W42.	Price- Code Transnorm (IE1-)K20. (IE2-)WE0./W20. Chapter	Standard motors	Pole-switching motors	Transnorm motors	Motors for converter-fed operation	Water-cooled motors	Slip-ring motors	Built-in motors	Fire-gas motors	Roller table motors, light-duty series	Roller table motors, ARB	Roller table motors, AFC	Roller table motors, DS..	Type of protection "eb" - Increased safety	Type of protection "d/de" - Flameproof enclosure	Type of protection "ec" - Increased safety	Protection by enclosure "tb", Zone 21	Protection by enclosure "tc", Zone 22	Motors for marine operation	Permanent magnet synchronous motors	Asynchronous generators
		2	2	3	4	5	6	7	8	9	9	9	9	10	10	10	10	10	11	12	13
Types of mounting																					
110	Flange without centring spigot	•	•	•	•	•	•	-	•	•	•	•	•	•	•	•	•	•	•	•	•
375	Deviating flange according to catalogue	•	•	•	•	•	•	-	•	•	•	•	•	•	•	•	•	•	•	•	•
111	Version with welded feet (steel feet), types of construction IM B6, IM B7, IM B8, IM V5 ⁴ , IM V6 ⁴)	•	•	•	•	•	•	-	•	•	•	•	•	•	•	•	•	•	•	•	•
369	Version in vertical construction with Q bearings (required as of 315 MY)	•	•	•	•	•	•	-	•	•	•	•	•	•	•	•	•	•	•	•	•
112	IM B35	•	•	•	•	•	•	-	•	•	•	•	•	•	•	•	•	•	•	•	•
476	IM V15 ⁴ , IM V36	•	•	•	•	•	•	-	•	•	•	•	•	•	•	•	•	•	•	•	•
339	IM B35K	•	•	•	•	•	•	-	•	•	•	•	•	•	•	•	•	•	•	•	•
113	IM B34	•	•	•	•	•	•	-	•	•	•	•	•	•	•	•	•	•	•	•	•
114	IM B5	•	•	•	•	•	•	-	•	•	•	•	•	•	•	•	•	•	•	•	•
362	IM V3 ⁴)	•	•	•	•	•	•	-	•	•	•	•	•	•	•	•	•	•	•	•	•
356	IM V1 ⁴)	•	•	•	•	•	•	-	•	•	•	•	•	•	•	•	•	•	•	•	•
117	Canopy for fan cover	•	•	•	•	-	•	-	•	-	-	•	•	•	•	•	•	•	•	•	•
338	IM B5 K	•	•	•	•	•	•	-	•	•	•	•	•	•	•	•	•	•	•	•	•
115	IM B14, IM V18, IM V19	•	•	•	•	•	•	-	•	•	•	•	•	•	•	•	•	•	•	•	•
142	IM 2202 (IM B17, 2nd shaft end included)	•	•	•	•	•	•	-	•	•	•	•	•	•	•	•	•	•	•	•	•
352	Type of construction B5/Furnace flange (standard design)/Aluminium fan	•	•	•	•	•	•	-	•	•	•	•	•	-	-	-	-	-	•	•	•
288	PAD-mounted 8 foot holes under 45 deg	•	•	•	•	•	•	-	•	•	•	•	•	-	-	-	-	-	•	•	•
475	IM V18, IM V19	•	•	•	•	•	•	-	•	•	•	•	•	•	•	•	•	•	•	•	•
481	Fan cover made of steel sheet	•	•	•	•	-	•	-	•	-	-	•	•	•	•	•	•	•	•	•	•
428	Flange ring K21R a = 660/800	•	•	•	•	•	•	•	•	•	•	•	•	•	-	•	•	•	•	•	•
429	Steel flange K22R 355 a=1000	•	•	•	•	•	•	•	•	•	•	•	•	•	-	•	•	•	•	•	•

		IEC/DIN (IE1-)K21. (IE2-)WE1./WE2./W21. (IE3-)W41./W42.																Price- Transnorm Code (IE1-)K20. (IE2-)WE0./W20. Chapter										
		56	63	71	80	90	100	100 LX, 112	132 T	132	160	180	200	225	250	280	315 S-MX	315 MY	315 L, LX	355 MY, M	355 MX, LY, L	400	450	500	560	630		
		.	56	63	71	80	90	100		112	132	160	180	200	225	250	280	315 S-MX	315 L, LX		
		Types of mounting																										
-	-	-	-	-	-	-	-	-	-	X	X	X	X	X	X	X	X	X	X	A	A	A	A	A	A	A	Flange without centring spigot	110
X	X	X	X	X	X	X	X	X	X	X	X	X	X	X	X	X	X	X	X	X	X	X	X	X	X	X	Deviating flange according to catalogue	375
-	-	-	-	-	-	-	-	-	-	X	X	X	X	X	X	-	-	-	-	-	-	-	-	N	N	N	Version with welded feet (steel feet), types of construction IM B6, IM B7, IM B8, IM V5 ⁴ , IM V6 ⁴)	111
-	-	-	-	-	-	-	-	-	-	X	X	X	X	X	X	X	X	X	X	X	X	X	-	-	-	-	Version in vertical construction with Q bearings (required as of 315 MY)	369
X	X	X	X	X	X	X	X	X	X	X	X	X	X	X	X	X	X	X	X	X	X	X	X	X	X	X	IM B35	112
X	X	X	X	X	X	X	X	X	X	X	X	X	X	X	X	X	X	X	X	X	X	X	X	A	A	A	IM V15 ⁴ , IM V36	476
-	X	X	X	X	X	X	-	-	-	-	-	-	-	-	-	-	-	-	-	-	-	-	-	-	-	-	IM B35K	339
X	X	X	X	X	X	X	X	X	X	A	A	A	A	A	A	A	A	A	A	A	A	A	A	A	A	A	IM B34	113
X	X	X	X	X	X	X	X	X	X	X	X	X	X	X	X	X	X	X	X	X	X	X	X	K	K	K	IM B5	114
X	X	X	X	X	X	X	X	X	X	X	X	X	X	X	X	X	X	A	A	A	A	A	A	A	A	A	IM V3 ⁴)	362
X	X	X	X	X	X	X	X	X	X	X	X	X	X	X	X	X	X	X	X	X	X	X	X	X	X	X	IM V1 ⁴)	356
X	X	X	X	X	X	X	X	X	X	X	X	X	X	X	X	X	X	X	X	X	X	X	X	X	X	X	Canopy for fan cover	117
-	X	X	X	X	X	X	-	-	-	-	-	-	-	-	-	-	-	-	-	-	-	-	-	-	-	-	IM B5 K	338
X	X	X	X	X	X	X	X	X	X	X	X				A	A	A	A	A	A	-	-	-	-	-	-	IM B14, IM V18, IM V19	115
-	-	-	-	-	-	-	-	-	X	X	X	X	X	X	X	X	-	-	-	-	-	-	-	-	-	-	IM 2202 (IM B17, 2nd shaft end included)	142
-	-	X	X	X	X	X	X	-	-	-	-	-	-	-	-	-	-	-	-	-	-	-	-	-	-	-	Type of construction B5/Furnace flange (standard design)/Aluminium fan	352
-	-	-	-	-	-	-	-	X	X	X	X	X	X	X	X	X	X	X	X	-	-	-	-	-	-	-	PAD-mounted 8 foot holes under 45 deg	288
X	X	X	X	X	X	X	X	X	X	X	-	-	-	-	-	-	-	-	-	-	-	-	-	-	-	-	IM V18, IM V19	475
X	X	X	X	X	X	X	X	X	X	X	X	X	X	X	X	X	X	X	X	X	X	X	X	X	X	X	Fan cover made of steel sheet	481
-	-	-	-	-	-	-	-	-	-	-	-	-	-	-	-	-	X	X	X	-	-	-	-	-	-	-	Flange ring K21R a=660/800	428
-	-	-	-	-	-	-	-	-	-	-	-	-	-	-	-	-	-	-	X	X	X	-	-	-	-	-	Steel flange K22R 355 a=1000	429

IEC/DIN (IE1-)K21. (IE2-)WE1./WE2./W21. (IE3-)W41./W42.	Price- Code Transnorm (IE1-)K20. (IE2-)WE0./W20. Chapter	Standard motors	Pole-switching motors	Transnorm motors	Motors for converter-fed operation	Water-cooled motors	Slip-ring motors	Built-in motors	Fire-gas motors	Roller table motors, light-duty series	Roller table motors, ARB	Roller table motors, AFC	Roller table motors, DS..	Type of protection "eb" - Increased safety	Type of protection "d/de" - Flameproof enclosure	Type of protection "ec" - Increased safety	Protection by enclosure "fb", Zone 21	Protection by enclosure "fc", Zone 22	Motors for marine operation	Permanent magnet synchronous motors	Asynchronous generators
		2	2	3	4	5	6	7	8	9	9	9	9	10	10	10	10	10	11	12	13
Mechanical versions																					
107	Special shaft (shorter, thicker and thinner, 2nd shaft end included) Standard steel, same bearing size)	•	•	•	•	•	•	•	•	•	•	•	•	•	•	•	•	•	•	•	•
108	Special shaft, 1 tapered shaft end (1:10)	•	•	•	•	•	•	•	•	•	•	•	•	•	•	•	•	•	•	•	•
427	Special shaft, 2 tapered shaft ends (1:10)	•	•	•	•	•	•	•	•	•	•	•	•	•	•	•	•	•	•	•	•
419	Shaft certificate 3.2 (required from some classification societies)	•	•	•	•	•	•	•	•	•	•	•	•	•	•	•	•	•	•	•	•
109	High-resistance rotor (Si 10)	•	•	•	•	•	•	-	•	•	•	•	•	-	-	-	-	-	•	•	•
116	Aluminium fan	•	•	•	•	-	•	-	•	•	-	-	•	•	•	•	•	•	•	•	•
190	Grey cast iron fan	•	•	•	•	-	•	-	•	•	-	-	•	•	•	•	•	•	•	•	•
195	Multi-wing fan (low-noise version)	•	•	•	•	-	•	-	•	•	-	-	•	•	•	•	•	•	•	•	•
330	Fan cover made of plastic	•	•	•	•	-	•	-	-	-	-	-	-	-	-	-	-	-	-	•	•
333	Protective cover for encoder	•	•	•	•	•	•	-	•	•	•	•	•	•	•	•	•	•	•	•	•
383	Vibration intensity B	•	•	•	•	•	•	-	•	•	•	•	•	•	•	•	•	•	•	•	•
165	Balancing against zero	•	•	•	•	•	•	-	•	•	•	•	•	•	•	•	•	•	•	•	•
166	High-speed version (HS)	•	•	•	•	•	•	-	•	•	•	•	•	•	•	•	•	•	•	•	•
376	Balancing with full key	•	•	•	•	•	•	-	•	•	•	•	•	•	•	•	•	•	•	•	•
143	Cooling type IC 418 (Non-ventilated version (K21R/K11R-0) (FAN))	•	•	•	•	•	•	-	•	•	•	•	•	-	-	-	-	-	•	•	•
445	Cooling type IC 410 (Non-ventilated version)	•	•	•	•	•	•	-	•	•	•	•	•	-	-	-	-	-	•	•	•
146	External earthing terminal on housing	•	•	•	•	•	•	-	•	•	•	•	•	•	•	•	•	•	•	•	•
161	Dredger version (incl. TII, vibration-resistant)	•	•	•	•	•	•	-	•	•	•	•	•	•	•	•	•	•	•	•	•
162	Version for the textile industry	•	•	•	•	•	•	-	-	-	-	-	-	-	-	-	-	-	•	•	•
163	Vibration-resistant version	•	•	•	•	•	•	-	•	•	•	•	•	•	•	•	•	•	•	•	•
177	Flange accuracy R according to DIN 42955	•	•	•	•	•	•	-	•	•	•	•	•	•	•	•	•	•	•	•	•
199	Condensate drain plug (1 piece)	•	•	•	•	•	•	-	•	•	•	•	•	•	•	•	•	•	•	•	•
201	Condensate drain holes with felt plug (2 pieces)	•	•	•	•	•	•	-	•	•	•	•	•	-	-	-	-	-	•	•	•
455	Condensate drain plug (1 piece) Ex	•	•	•	•	•	•	-	•	•	•	•	•	•	•	•	•	•	•	•	•
280	Additional foot holes at the top of the housing	•	•	•	•	•	•	-	•	•	•	•	•	•	•	•	•	•	•	•	•
425	8 threaded holes in the housing on terminal box side	•	•	•	•	•	•	-	•	•	•	•	•	•	•	•	•	•	•	•	•
285	Screen cut out from fan cover	•	•	•	•	•	•	-	•	•	•	•	•	-	-	-	-	-	•	•	•
294	Housing with load bracket thread (2 pieces)	•	•	•	•	•	•	-	•	•	•	•	•	•	•	•	•	•	•	•	•
322	Special fan	•	•	•	•	•	•	-	•	•	•	•	•	-	-	•	-	•	•	•	•
331	Foot contact face, milled	•	•	•	•	•	•	-	•	•	•	•	•	•	•	•	•	•	•	•	•
411	Housing with ring nut (lifting eye bolt)	•	•	•	•	•	•	-	•	•	•	•	•	•	•	•	•	•	•	•	•
420	Housing in GGG50	•	•	•	•	•	•	-	•	•	•	•	•	•	•	•	•	•	•	•	•
421	End shield on D- or N-side in GGG50 (up to shaft size 132 T in GGG40)	•	•	•	•	•	•	-	•	•	•	•	•	•	•	•	•	•	•	•	•
422	Flanged end shield in GGG50	•	•	•	•	•	•	-	•	•	•	•	•	•	•	•	•	•	•	•	•
423	Bearing cover made of steel (each piece)	•	•	•	•	•	•	-	•	•	•	•	•	•	•	•	•	•	•	•	•
186	Tensioning rail (1 set= 2 pcs)	•	•	•	•	•	•	-	•	•	•	•	•	•	•	•	•	•	•	•	•
432	Foundation block (Form A without cams 1 set= 4 pcs)	•	•	•	•	•	•	-	•	•	•	•	•	•	•	•	•	•	•	•	•
433	additional eye bolt	•	•	•	•	•	•	-	•	•	•	•	•	•	•	•	•	•	•	•	•
386	RFID-Transponder (Memory design)	•	•	•	•	•	•	-	•	•	•	•	•	•	•	•	•	•	•	•	•
463	Retrofit set for memory design (RFID-Transponder)	•	•	•	•	•	•	-	•	•	•	•	•	•	•	•	•	•	•	•	•
474	Earthing ring for insulated bearings on both sides	•	•	•	•	•	•	-	•	•	•	•	•	•	•	•	•	•	•	•	•

											IEC/DIN																
											(IE1-)K21.																
											(IE2-)WE1./WE2./W21.																
											(IE3-)W41./W42.																
56	63	71	80	90	100	100 LX, 112	132 T	132	160	180	200	225	250	280	315 S-MX	315 MY	315 L, LX	355 MY, M	355 MX, LY, L	400	450	500	560	630	Price- Transm Code (IE1-)K20. (IE2-)WE0./W20. Chapter		
.	56	63	71	80	90	100		112	132	160	180	200	225	250	280	315 S-MX	315 L, LX			
Mechanical versions																											
X	X	X	X	X	X	X	X	X	X	X	X	X	X	X	X	X	X	X	X	X	X	X	X	X	X	Special shaft (shorter, thicker and thinner, 2nd shaft end included) Standard steel, same bearing size)	107
X	X	X	X	X	X	X	X	X	X	X	X	X	X	X	X	X	X	X	X	X	X	X	X	X	X	Special shaft, 1 tapered shaft end (1:10)	108
-	-	-	-	-	-	-	-	X	X	X	X	X	X	X	X	X	X	X	X	X	X	X	X	X	X	Special shaft, 2 tapered shaft ends (1:10)	427
-	-	-	-	-	-	-	-	X	X	X	X	X	X	X	X	X	X	X	X	X	X	X	X	X	X	Shaft certificate 3.2 (required from some classification societies)	419
X	X	X	X	X	X	X	X	X	X	X	X	X	X	X	X	X	X	X	X	X	-	-	-	-	-	High-resistance rotor (Si 10)	109
X	X	X	X	X	X	X	X	X	X	X	X	X	X	X	X	X	X	X	X	X	-	-	-	-	-	Aluminium fan	116
-	-	-	-	-	-	-	-	-	-	X	X	X	X	X	X	X	X	-	-	-	-	-	-	-	-	Grey cast iron fan	190
-	-	-	-	-	-	-	-	X	X	X	X	X	X	X	X	X	X	X	X	X	X	X	X	X	X	Multi-wing fan (low-noise version)	195
-	-	-	-	-	-	-	-	X	X	X	X	-	-	-	-	-	-	-	-	-	-	-	-	-	-	Fan cover made of plastic	330
-	-	-	-	-	-	-	-	X	X	X	X	X	X	X	X	X	X	X	X	X	X	X	X	X	X	Protective cover for encoder	333
X	X	X	X	X	X	X	X	X	X	X	X	X	X	X	X	X	X	X	X	X	X	X	X	X	X	Vibration intensity B	383
-	-	-	-	-	-	-	-	X	X	X	X	X	X	X	X	X	X	X	X	X	X	X	X	X	X	Balancing against zero	165
-	-	-	-	-	-	-	-	X	X	X	X	X	X	X	X	X	X	X	X	X	X	X	X	X	X	High-speed version (HS)	166
-	-	-	-	-	-	-	-	X	X	X	X	X	X	X	X	X	X	X	X	X	X	X	X	X	X	Balancing with full key	376
X	X	X	X	X	X	X	X	X	X	X	X	X	X	X	X	X	X	X	X	X	X	X	X	X	X	Cooling type IC 418 (Non-ventilated version (K21R/K11R-0) (FAN))	143
X	X	X	X	X	X	X	X	X	X	X	X	X	X	X	X	X	X	X	X	X	X	X	X	X	X	Cooling type IC 410 (Non-ventilated version)	445
X	X	X	X	X	X	X	X	X	X	X	X	X	X	X	X	X	X	X	X	X	X	X	X	X	X	External earthing terminal on housing	146
-	-	-	-	-	-	-	-	X	X	X	X	X	X	X	X	X	X	X	X	X	X	X	X	X	X	Dredger version (incl. TII, vibration-resistant)	161
X	X	X	X	X	X	X	X	X	X	X	X	X	X	X	X	X	X	-	-	-	-	-	-	-	-	Version for the textile industry	162
X	X	X	X	X	X	X	X	X	X	X	X	X	X	X	X	X	X	-	-	-	-	-	-	-	-	Vibration-resistant version	163
X	X	X	X	X	X	X	X	X	X	X	X	X	X	X	X	X	X	X	X	X	X	X	X	X	X	Flange accuracy R according to DIN 42955	177
X	X	X	X	X	X	X	X	X	X	X	X	X	X	X	X	X	X	X	X	X	X	X	X	X	X	Condensate drain plug (1 piece)	199
X	X	X	X	X	X	X	X	X	X	X	X	X	X	X	X	X	X	X	X	X	X	X	X	X	X	Condensate drain holes with felt plug (2 pieces)	201
X	X	X	X	X	X	X	X	X	-	-	-	-	-	-	-	-	-	-	-	-	-	-	-	-	-	Condensate drain plug (1 piece) Ex	455
-	-	-	-	-	-	-	-	X	X	X	X	X	X	X	X	X	X	-	-	-	-	-	-	-	-	Additional foot holes at the top of the housing	280
-	-	-	-	-	-	-	-	X	X	X	X	X	X	X	X	X	X	X	X	X	X	X	X	X	X	8 threaded holes in the housing on terminal box side	425
X	X	X	X	X	X	X	X	X	X	X	X	X	X	X	X	X	X	X	X	X	X	X	X	X	X	Screen cut out from fan cover	285
-	-	-	-	-	-	-	-	-	-	-	-	-	-	X	N	N	N	N	N	N	A	A	A	A	A	Housing with load bracket thread (2 pieces)	294
-	-	-	-	-	-	-	-	X	X	X	X	X	X	X	X	X	X	X	X	X	X	X	X	X	X	Special fan	322
-	-	-	-	-	-	-	-	X	X	X	X	X	X	-	-	-	-	-	-	-	-	-	-	-	-	Foot contact face, milled	331
-	-	-	-	-	-	-	-	X	X	X	X	X	X	A	A	A	A	A	A	A	A	A	A	A	A	Housing with ring nut (lifting eye bolt)	411
A	A	A	A	A	A	A	A	A	X	X	X	X	X	X	X	X	X	X	X	X	X	X	X	X	X	Housing in GGG50	420
A	A	A	A	A	A	A	A	A	X	X	X	X	X	X	X	X	X	X	X	X	X	X	X	X	X	End shield on D- or N-side in GGG50 (up to shaft size 132 T in GGG40)	421
A	A	A	A	A	A	A	A	A	X	X	X	X	X	X	X	X	X	X	X	X	X	X	X	X	X	Flanged end shield in GGG50	422
-	-	-	-	-	-	-	-	X	X	X	X	X	X	X	X	X	X	X	X	X	X	N	N	N	N	Bearing cover made of steel (each piece)	423
-	-	-	-	-	-	-	-	X	X	X	X	X	X	X	X	X	X	X	X	X	X	X	X	X	X	Tensioning rail (1 set = 2 pcs)	186
-	-	-	-	-	-	-	-	X	X	X	X	X	X	X	X	X	X	X	X	X	X	X	X	X	X	Foundation block (Form A without cams 1 set = 4 pcs)	432
-	-	-	-	-	-	-	-	X	X	X	-	-	-	-	-	-	-	-	-	-	-	-	-	-	-	additional eye bolt	433
-	-	-	-	-	-	-	-	X	X	X	X	X	X	X	X	X	X	X	X	X	X	X	X	X	X	RFID-Transponder (Memory design)	386
-	-	-	-	-	-	-	-	X	X	X	X	X	X	X	X	X	X	X	X	X	X	X	X	X	X	Retrofit set for memory design (RFID-Transponder)	463
-	-	-	-	-	-	-	-	-	-	-	-	-	-	-	X	X	X	X	X	X	X	X	X	X	X	Earthing ring for insulated bearings on both sides	474

Price-Code	Transnorm (IE1-)K20. (IE2-)WE0./W20. Chapter	Standard motors	Pole-switching motors	Transnorm motors	Motors for converter-fed operation	Water-cooled motors	Slip-ring motors	Built-in motors	Fire-gas motors	Roller table motors, light-duty series	Roller table motors, ARB	Roller table motors, AFC	Roller table motors, DS..	Type of protection "eb" - Increased safety	Type of protection "d/de" - Flameproof enclosure	Type of protection "ec" - Increased safety	Protection by enclosure "fb", Zone 21	Protection by enclosure "fc", Zone 22	Motors for marine operation	Permanent magnet synchronous motors	Asynchronous generators
Corrosion protection/painting																					
133	Special colours	•	•	•	•	•	•	-	•	•	•	•	•	•	•	•	•	•	•	•	•
452	Special colours, not available in colour system 01 (incl. colour system 02)	•	•	•	•	•	•	-	•	•	•	•	•	•	•	•	•	•	•	•	•
135	Colour system 02; 02S „worldwide“ (outdoors, indoors with high humidity) Corrosion class KK C2-C3 acc, to EN ISO 12944-2:1998	•	•	•	•	•	•	-	•	•	•	•	•	•	•	•	•	•	•	•	•
354	Colour system 04 (maritime/harbour climate)	•	•	•	•	•	•	-	•	•	•	•	•	•	•	•	•	•	•	•	•
446	Colour system 05 (special paint for thermal class H)	•	•	•	•	•	•	-	•	•	•	•	•	•	•	•	•	•	•	•	•
368	Colour system 06 (higher temperatures, humidity, outdoors) Corrosion class KK C2-C3 acc, to EN ISO 12944-2:1998	•	•	•	•	•	•	-	•	•	•	•	•	•	•	•	•	•	•	•	•
134	Colour system 07 (chemistry, higher temperatures, humidity, decontaminable) Corrosion class KK C3 acc, to EN ISO 12944-2:1998	•	•	•	•	•	•	-	•	•	•	•	•	•	•	•	•	•	•	•	•
443	Colour system 09L „Offshore“ (UV resistant) Corrosion class KK C3 acc, to EN ISO 12944-2:1998	•	•	•	•	•	•	-	•	•	•	•	•	-	-	-	-	-	•	•	•
311	Colour system 09S „Offshore“ (UV resistant) Corrosion class KK C4/5 acc, to EN ISO 12944-2:1998	•	•	•	•	•	•	-	•	•	•	•	•	-	-	-	-	-	•	•	•
460	Colour system 010L „Offshore“ Ex (> 200 mym)	-	-	-	-	-	-	-	-	-	-	-	-	•	•	•	•	•	•	-	-
461	Colour system 010S „Offshore“ Ex (> 200 mym)	-	-	-	-	-	-	-	-	-	-	-	-	•	•	•	•	•	•	-	-
136	Protection against elevated climatic requirements (TII)	•	•	•	•	•	•	-	•	•	•	•	•	•	•	•	•	•	•	•	•
412	Climate-resistant rotor	•	•	•	•	•	•	-	•	•	•	•	•	•	•	•	•	•	•	•	•
173	Layer thicknesses increased by 30 µm each	•	•	•	•	•	•	-	•	•	•	•	•	•	•	•	•	•	•	•	•
200	Stainless steel external bolts	•	•	•	•	•	•	-	•	•	•	•	•	•	•	•	•	•	•	•	•
286	Fan cover or N-bearing cover or N-end shield painted on the inside	•	•	•	•	•	•	-	•	•	•	•	•	•	•	•	•	•	•	•	•
287	Fan sprayed with epoxy resin varnish	•	•	•	•	•	•	-	•	•	•	•	•	•	•	•	•	•	•	•	•
351	Paint system acc, to special-drawing 3135	•	•	•	•	•	•	-	•	•	•	•	•	•	•	•	•	•	•	•	•
315	Zinc-plated fan cover	•	•	•	•	•	•	-	•	•	•	•	•	•	•	•	•	•	•	•	•
424	Flange free of grease and paint residues	•	•	•	•	•	•	-	•	•	•	•	•	•	•	•	•	•	•	•	•
Attachments																					
96	Centric attachment of encoder (bell/intermediate flange, shaft end, coupling) (K21F, K210)	•	•	•	•	•	•	-	•	•	•	•	•	•	•	•	•	•	•	•	•
99	Centric attachment by means of a flange end shield, N-side (IM 2202)	•	•	•	•	•	•	-	•	•	•	•	•	•	•	•	•	•	•	•	•
367	Centric attachment by means of combined mount	•	•	•	•	•	•	-	•	•	•	•	•	•	•	•	•	•	•	•	•
100	Attachment of tachometer and encoder (behind fan cover) (put-on version without aggregate)	•	•	•	•	•	•	-	•	•	•	•	•	•	•	•	•	•	•	•	•
418	Installation of Harting connector/switch (without plug)	•	•	•	•	•	•	-	•	•	•	•	•	•	-	-	-	-	-	-	•
150	Attachment of backstop (without lock)	•	•	•	•	•	•	-	•	•	•	•	•	•	•	•	•	•	•	•	•
358	Brake attachment	•	•	•	•	•	•	-	-	-	•	•	•	•	•	•	•	•	•	•	•
479	Attachment of external fan	•	•	•	•	-	•	-	-	•	•	•	•	•	•	•	•	•	•	•	•
465	Attachment of gear	•	•	•	•	•	•	-	-	•	•	•	•	-	-	-	-	-	•	•	•

											IEC/DIN (IE1-)K21. (IE2-)WE1./WE2./W21. (IE3-)W41./W42.															
56	63	71	80	90	100	100 LX, 112	132 T	132	160	180	200	225	250	280	315 S-MX	315 MY	315 L, LX	355 MY, M	355 MX, LY, L	400	450	500	560	630		
											Price- Transm Code (IE1-)K20. (IE2-)WE0./W20. Chapter															
Corrosion protection/painting																										
X	X	X	X	X	X	X	X	X	X	X	X	X	X	X	X	X	X	X	X	X	X	X	X	X	Special colours	133
X	X	X	X	X	X	X	X	X	X	X	X	X	X	X	X	X	X	X	X	X	X	X	X	X	Special colours, not available in colour system 01 (incl. colour system 02)	452
X	X	X	X	X	X	X	X	X	X	X	X	X	X	X	X	X	X	X	X	X	X	X	X	X	Colour system 02; 02S „worldwide“ (outdoors, indoors with high humidity) Corrosion class KK C2-C3 acc, to EN ISO 12944-2:1998	135
-	-	-	-	-	-	-	-	X	X	X	X	X	X	X	X	X	X	X	X	X	X	X	X	X	Colour system 04 (maritime/harbour climate)	354
-	-	-	-	-	-	-	-	X	X	X	X	X	X	X	X	X	X	X	X	X	X	X	X	X	Colour system 05 (special paint for thermal class H)	446
X	X	X	X	X	X	X	X	X	X	X	X	X	X	X	X	X	X	X	X	X	X	X	X	X	Colour system 06 (higher temperatures, humidity, outdoors) Corrosion class KK C2-C3 acc, to EN ISO 12944-2:1998	368
X	X	X	X	X	X	X	X	X	X	X	X	X	X	X	X	X	X	X	X	X	X	X	X	X	Colour system 07 (chemistry, higher temperatures, humidity, decontaminable) Corrosion class KK C3 acc, to EN ISO 12944-2:1998	134
A	A	A	A	A	A	A	A	A	X	X	X	X	X	X	X	X	X	X	X	X	X	X	X	X	Colour system 09L „Offshore“ (UV resistant) Corrosion class KK C3 acc, to EN ISO 12944-2:1998	443
A	A	A	A	A	A	A	A	A	X	X	X	X	X	X	X	X	X	X	X	X	X	X	X	X	Colour system 09S „Offshore“ (UV resistant) Corrosion class KK C4/5 acc, to EN ISO 12944-2:1998	311
A	A	A	A	A	A	A	A	A	X	X	X	X	X	X	X	X	X	X	X	X	X	X	X	X	Colour system 010L „Offshore“ Ex (> 200 mym)	460
A	A	A	A	A	A	A	A	A	X	X	X	X	X	X	X	X	X	X	X	X	X	X	X	X	Colour system 010S „Offshore“ Ex (> 200 mym)	461
X	X	X	X	X	X	X	X	X	X	X	X	X	X	X	X	X	X	X	X	X	X	X	X	X	Protection against elevated climatic requirements (TII)	136
X	X	X	X	X	X	X	X	X	X	X	X	X	X	X	X	X	X	X	X	X	X	X	X	X	Climate-resistant rotor	412
X	X	X	X	X	X	X	X	X	X	X	X	X	X	X	X	X	X	X	X	X	X	X	X	X	Layer thicknesses increased by 30 µm each	173
-	X	X	X	X	X	X	X	X	X	X	X	X	X	X	X	X	X	X	X	X	X	X	X	X	Stainless steel external bolts	200
X	X	X	X	X	X	X	X	X	X	X	X	X	X	X	X	X	X	X	X	X	X	X	X	X	Fan cover or N-bearing cover or N-end shield painted on the inside	286
-	-	-	-	-	-	-	-	X	X	X	X	X	X	X	X	X	X	X	X	X	X	X	X	X	Fan sprayed with epoxy resin varnish	287
X	X	X	X	X	X	X	X	-	-	-	-	-	-	-	-	-	-	-	-	-	-	-	-	-	Paint system acc, to special-drawing 3135	351
X	X	X	X	X	X	X	X	X	X	X	X	X	X	X	X	X	X	X	X	X	X	X	X	X	Zinc-plated fan cover	315
X	X	X	X	X	X	X	X	X	X	X	X	X	X	X	X	X	X	X	X	X	X	X	X	X	Flange free of grease and paint residues	424
Attachments																										
A	A	A	A	A	A	A	A	X	X	X	X	X	X	X	X	X	X	X	X	X	X	X	X	X	Centric attachment of encoder (bell/intermediate flange, shaft end, coupling) (K21F, K21O)	96
A	A	A	A	A	A	A	A	X	X	X	X	X	X	X	X	K	K	K	K	K	K	K	K	K	Centric attachment by means of a flange end shield, N-side (IM 2202)	99
X	X	X	X	X	X	X	X	X	X	X	X	X	X	X	X	A	A	A	A	A	A	A	A	A	Centric attachment by means of combined mount	367
A	A	A	A	A	A	A	A	X	X	X	X	X	X	X	X	X	X	X	X	X	X	X	X	X	Attachment of tachometer and encoder (behind fan cover) (put-on version without aggregate)	100
-	-	-	-	-	-	-	-	X	X	X	A	A	A	A	A	A	A	A	A	A	A	A	A	A	Installation of Harting connector/switch (without plug)	418
-	-	-	-	-	-	-	-	X	X	X	X	X	X	X	X	X	X	X	X	X	X	X	X	X	Attachment of backstop (without lock)	150
X	X	X	X	X	X	X	X	X	X	X	X	X	X	X	X	X	X	X	X	X	X	X	X	X	Brake attachment	358
X	X	X	X	X	X	X	X	X	X	X	X	X	X	X	X	X	X	X	X	X	X	X	X	X	Attachment of external fan	479
-	-	-	-	-	-	-	-	X	X	X	X	X	X	X	X	X	X	X	X	X	X	X	X	X	Attachment of gear	465

IEC/DIN (IE1-)K21. (IE2-)WE1./WE2./W21. (IE3-)W41./W42.	Price- Code Transnorm (IE1-)K20. (IE2-)WE0./W20. Chapter	Standard motors 2	Pole-switching motors 2	Transnorm motors 3	Motors for converter-fed operation 4	Water-cooled motors 5	Slip-ring motors 6	Built-in motors 7	Fire-gas motors 8	Roller table motors, light-duty series 9	Roller table motors, ARB 9	Roller table motors, AFC 9	Roller table motors, DS.. 9	Type of protection "eb" - Increased safety 10	Type of protection "d/de" - Flameproof enclosure 10	Type of protection "ec" - Increased safety 10	Protection by enclosure "fb", Zone 21 10	Protection by enclosure "fc", Zone 22 10	Motors for marine operation 11	Permanent magnet synchronous motors 12	Asynchronous generators 13
95 Oil-tight design (radial shaft sealing ring, N-side fixed bearing)		•	•	•	•	•	•	-	•	•	•	•	•	•	•	•	•	•	•	•	•
118 Radial sealing ring, D-side (incl. N-side fixed bearing)		•	•	•	•	•	•	-	•	•	•	•	•	•	•	•	•	•	•	•	•
119 Fixed bearing D-side		•	•	•	•	•	•	-	•	•	•	•	•	•	•	•	•	•	•	•	•
390 Fixed bearing, D-side, backlash-free		•	•	•	•	•	•	-	•	•	•	•	•	•	•	•	•	•	•	•	•
120 Fixed bearing N-side		•	•	•	•	•	•	-	•	•	•	•	•	•	•	•	•	•	•	•	•
121 Angular contact bearing D-side		•	•	•	•	•	•	-	•	•	•	•	•	•	•	•	•	•	•	•	•
122 Elevated transverse forces, D-side (incl. of fixed bearing, N-side)		•	•	•	•	•	•	-	•	•	•	•	•	•	•	•	•	•	•	•	•
415 Insulated roller bearing		•	•	•	•	•	•	-	•	•	•	•	•	•	•	•	•	•	•	•	•
340 Reinforced bearing, D-side (inclusive of fixed bearing series 42..)		•	•	•	•	•	•	-	•	•	•	•	•	•	•	•	•	•	•	•	•
332 Labyrinth seal		•	•	•	•	•	•	-	•	•	•	•	•	•	•	•	•	•	•	•	•
342 Bearing sealing with combined seal, D-side		•	•	•	•	•	•	-	•	•	•	•	•	•	•	•	•	•	•	•	•
151 Bearing control with a temperature sensor for each bearing point (D-side/N-side) (without additional terminal box)		•	•	•	•	•	•	-	•	•	•	•	•	•	•	•	•	•	•	•	•
153 Bearing control with PT100 (2 conductors) for each bearing point		•	•	•	•	•	•	-	•	•	•	•	•	•	•	•	•	•	•	•	•
154 Bearing control with PT100 (4 conductors) for each bearing point		•	•	•	•	•	•	-	•	•	•	•	•	•	•	•	•	•	•	•	•
193 Relubricating device ^{6) 8)}		•	•	•	•	•	•	-	•	•	•	•	•	•	•	•	•	•	•	•	•
262 Insulated bearing, N-side		•	•	•	•	•	•	-	•	•	•	•	•	•	•	•	•	•	•	•	•
413 Insulated bearing, D-side		•	•	•	•	•	•	-	•	•	•	•	•	•	•	•	•	•	•	•	•
278 Flat lubricating nipple, stainless steel (for both sides)		•	•	•	•	•	•	-	•	•	•	•	•	•	•	•	•	•	•	•	•
394 Tapered lubricating nipple (for both sides)		•	•	•	•	•	•	-	•	•	•	•	•	•	•	•	•	•	•	•	•
321 Tapered lubricating nipple of stainless steel (for both sides)		•	•	•	•	•	•	-	•	•	•	•	•	•	•	•	•	•	•	•	•
283 SPM bearing control with accessories (vIB) (per bearing arrangement)		•	•	•	•	•	•	-	•	•	•	•	•	•	•	•	•	•	•	•	•
284 SPM prepared without nipple		•	•	•	•	•	•	-	•	•	•	•	•	•	•	•	•	•	•	•	•
152 SPM bearing control (with nipple) (2 pieces)		•	•	•	•	•	•	-	•	•	•	•	•	•	•	•	•	•	•	•	•
434 SPM bearing control (with stainless steel nipple) (2 pieces)		•	•	•	•	•	•	-	•	•	•	•	•	•	•	•	•	•	•	•	•
467 SPM bearing control with accessories (per bearing arrangement)		•	•	•	•	•	•	-	•	•	•	•	•	•	•	•	•	•	•	•	•
306 Bearing seal with radial shaft sealing ring 9RB		•	•	•	•	•	•	-	•	•	•	•	•	•	•	•	•	•	•	•	•
323 Double bearing seal, D-side (2 radial shaft sealing rings & grease compartment) ⁷⁾		•	•	•	•	•	•	-	•	•	•	•	•	•	•	•	•	•	•	•	•
364 Axial shaft sealing ring		•	•	•	•	•	•	-	•	•	•	•	•	•	•	•	•	•	•	•	•
365 γ-ring		•	•	•	•	•	•	-	•	•	•	•	•	•	•	•	•	•	•	•	•
127 Special grease		•	•	•	•	•	•	-	•	•	•	•	•	•	•	•	•	•	•	•	•
Miscellaneous																					
147 2nd rating plate, loose		•	•	•	•	•	•	•	•	•	•	•	•	•	•	•	•	•	•	•	•
148 Customer's rating plate		•	•	•	•	•	•	•	•	•	•	•	•	•	•	•	•	•	•	•	•
414 Position plate		•	•	•	•	•	•	•	•	•	•	•	•	•	•	•	•	•	•	•	•
149 Stainless steel rating plate		•	•	•	•	•	•	•	•	•	•	•	•	•	•	•	•	•	•	•	•
253 Silicon-free design		•	•	•	•	•	•	•	•	•	•	•	•	•	•	•	•	•	•	•	•
410 Handling costs for items supplied by customer		•	•	•	•	•	•	-	•	•	•	•	•	•	•	•	•	•	•	•	•
431 Coolant temperature ≥ 100 °C		•	•	•	•	•	•	•	•	•	•	•	•	•	•	•	•	•	•	•	•

- N... standard version
- X... special version at extra charge
- O... without extra charge
- A... upon request
- K... not available
- not applicable

¹⁾ K22. 355 MX2, 4 is standard version
²⁾ K22. 355 MY, M und MX6, 8 is standard version
³⁾ Product range from Thurm suitable for converter operation
⁴⁾ additionally Q-bearing for IM V15, IM V3, IM V1, IM V5, IM V6 (from size 315 MY necessary)
⁵⁾ only possible for 200 LX2
⁶⁾ relubrication device D-end not possible due to design version K21. 132 S, SX, M6, 8 und K21. 160 M, MX8
⁷⁾ not possible when lubrication device is installed
⁸⁾ Lubrication device standard for all motors from size K21. 315 MX upwards

														IEC/DIN													
														(IE1-)K21.													
														(IE2-)WE1./WE2./W21.													
														(IE3-)W41./W42.													
56	63	71	80	90	100	100 LX, 112	132 T	132	160	180	200	225	250	280	315 S-MX	315 MY	315 L, LX	355 MY, M	355 MX, LY, L	400	450	500	560	630			
.	56	63	71	80	90	100		112	132	160	180	200	225	250	280	315 S-MX	315 L, LX			
																										Price- Transm Code (IE1-)K20. (IE2-)WE0./W20. Chapter	
																										Bearing arrangement	
X	X	X	X	X	X	X	X	X	X	X	X	X	X	X	X	X	X	A	A	A	A	A	A	A	A	Oil-tight design (radial shaft sealing ring, N-side fixed bearing)	95
X	X	X	X	X	X	X	X	X	X	X	X	X	X	X	X	X	X	X	X	X	X	X	X	X	X	Radial sealing ring, D-side (incl. N-side fixed bearing)	118
X	X	X	X	X	X	X	X	X	X	X	X	X	X	X	X	X	X	X	X	X	X	X	X	X	X	Fixed bearing D-side	119
-	-	-	-	-	-	-	-	X	X	X	X	X	A	A	A	A	A	A	A	A	A	A	A	A	Fixed bearing, D-side, backlash-free	390	
X	X	X	X	X	X	X	X	X	X	X	N	N	N	N	N	N	N	N	N	N	N	N	N	N	Fixed bearing N-side	120	
X	X	X	X	X	X	X	X	X	X	X	X	X	X	X	X	X	X	X	X	X	X	X	X	X	Angular contact bearing D-side	121	
X	X	X	X	X	X	X	X	X	X	X	X	X	X	X	X	X	X	X	X	X	X	X	X	X	Elevated transverse forces, D-side (incl. of fixed bearing, N-side)	122	
-	-	-	-	-	-	-	-	-	-	-	-	-	-	-	X	X	X	X	X	X	X	X	X	X	Insulated roller bearing	415	
-	-	X	X	X	X	X	X	-	-	-	-	-	-	-	-	-	-	-	-	-	-	-	-	-	Reinforced bearing, D-side (inclusive of fixed bearing series 42..)	340	
-	-	-	-	-	-	-	-	X	X	X	X	X	X	X	X	X	X	X	X	X	X	X	X	X	Labyrinth seal	332	
X	X	X	X	X	X	X	X	X	X	X	X	X	X	X	X	X	X	A	A	A	A	A	A	A	Bearing sealing with combined seal, D-side	342	
-	-	-	-	-	-	-	-	X	X	X	X	X	X	X	X	X	X	X	X	X	X	X	X	X	Bearing control with a temperature sensor for each bearing point (D-side/N-side) (without additional terminal box)	151	
-	-	-	-	-	-	-	-	X	X	X	X	X	X	X	X	X	X	X	X	X	X	X	X	X	Bearing control with PT100 (2 conductors) for each bearing point	153	
-	-	-	-	-	-	-	-	X	X	X	X	X	X	X	X	X	X	X	X	X	X	X	X	X	Bearing control with PT100 (4 conductors) for each bearing point	154	
K	K	K	K	K	K	K	K	X	X	X	X	X	X	X	X	N	N	N	N	N	N	N	N	N	Relubricating device ⁶⁾	193	
X	X	X	X	X	X	X	X	X	X	X	X	X	X	X	X	X	X	X	X	X	X	X	X	X	Insulated bearing, N-side	262	
								X	X	X	X	X	X	X	X	X	X	X	X	X	X	X	X	X	Insulated bearing, D-side	413	
-	-	-	-	-	-	-	-	X	X	X	X	X	X	X	X	X	X	X	X	X	X	X	X	X	Flat lubricating nipple, stainless steel (for both sides)	278	
-	-	-	-	-	-	-	-	X	X	X	X	X	X	X	X	X	X	X	X	X	X	X	X	X	Tapered lubricating nipple (for both sides)	394	
-	-	-	-	-	-	-	-	X	X	X	X	X	X	X	X	X	X	X	X	X	X	X	X	X	Tapered lubricating nipple of stainless steel (for both sides)	321	
-	-	-	-	-	-	-	-	-	-	-	-	-	-	X	X	X	X	X	X	X	X	X	X	X	SPM bearing control with accessories (vIB) (per bearing arrangement)	283	
-	-	-	-	-	-	-	-	X	X	X	X	X	X	X	X	X	X	X	X	X	X	X	X	X	SPM prepared without nipple	284	
-	-	-	-	-	-	-	-	X	X	X	X	X	X	X	X	X	X	X	X	X	X	X	X	X	SPM bearing control (with nipple) (2 pieces)	152	
-	-	-	-	-	-	-	-	X	X	X	X	X	X	X	X	X	X	X	X	X	X	X	X	X	SPM bearing control (with stainless steel nipple) (2 pieces)	434	
-	-	-	-	-	-	-	-	X	X	X	X	X	X	X	X	X	X	X	X	X	X	X	X	X	SPM bearing control with accessories (per bearing arrangement)	467	
-	-	-	-	-	-	-	-	X	X	X	X	X	X	X	X	X	X	X	X	X	X	X	X	X	Bearing seal with radial shaft sealing ring 9RB	306	
-	-	-	-	-	-	-	-	X	X	X	X	X	X	X	X	X	X	X	X	X	X	X	X	X	Double bearing seal, D-side (2 radial shaft sealing rings & grease compartment) ⁷⁾	323	
X	X	X	X	X	X	X	X	X	X	X	X	X	X	X	X	X	X	X	X	X	X	X	X	X	Axial shaft sealing ring	364	
X	X	X	X	X	X	X	X	X	X	X	X	X	X	X	X	N	N	K	K	K	K	K	K	K	γ-ring	365	
X	X	X	X	X	X	X	X	A	A	A	A	A	A	A	A	A	A	A	A	A	A	A	A	A	Special grease	127	
																										Miscellaneous	
X	X	X	X	X	X	X	X	X	X	X	X	X	X	X	X	X	X	X	X	X	X	X	X	X	X	2nd rating plate, loose	147
O	O	O	O	O	O	O	O	O	O	O	O	O	O	O	O	O	O	O	O	O	O	O	O	O	O	Customer's rating plate	148
X	X	X	X	X	X	X	X	X	X	X	X	X	X	X	X	X	X	X	X	X	X	X	X	X	X	Position plate	414
X	X	X	X	X	X	X	X	X	X	X	X	X	X	X	X	X	X	X	X	X	X	X	X	X	X	Stainless steel rating plate	149
X	X	X	X	X	X	X	X	X	X	X	X	X	X	X	X	X	X	X	X	X	X	X	X	X	X	Silicon-free design	253
X	X	X	X	X	X	X	X	X	X	X	X	X	X	X	X	X	X	X	X	X	X	X	X	X	X	Handling costs for items supplied by customer	410
X	X	X	X	X	X	X	X	X	X	X	X	X	X	X	X	X	X	X	X	X	X	X	X	X	X	Coolant temperature ≥ 100 °C	431



VEM MOTOR

Standard motors

Contents

Product description	2/2
Overview of technical data	2/5
Motor selection data	
Series W4.R	
for Premium Efficiency IE3	2/6
Series WE.R	
for High Efficiency IE2	2/14
Series K2.R	
for Standard Efficiency IE1	2/26
Series K2.R	
10- to 24-pole motors	2/30
Series K21R-S2	
for duty type S2, 10/30/60 min	2/32
Series K21R-S3	
for duty type S3, 25/40/60 %c.d.f.	2/40
Series K21R-S6	
for duty type S6, 25/40/60/80 %c.d.f.	2/48
Series K2.R for two speeds	2/56
Series K2.R for three speeds	2/75
Series K2.R for four speeds	2/83
Bearings	2/84
Terminal boxes	2/106
Dimensions	2/109

Product description

Electric drives are today used throughout industry in the most diverse variants. With their specific properties, they determine the efficiency of countless production processes. The VEM range of three-phase asynchronous motors satisfies all customer demands relating to application versatility, improved operating data, environmental compatibility and maximum operating reliability. Aimed at the broad European market, VEM motors promise:

- high motor efficiency as the basis for energy-efficient performance
- universal applications and reduced stock levels thanks to IP 55 protection as standard (higher degrees of protection up to IP 66 upon request)
- options for terminal box arrangements on the left, top or right
- enhanced service life, reliability and thermal overload capacity to thermal class F with corresponding thermal reserves as standard (thermal class H available as a special version)
- environment-friendly operation based on a low-noise ventilation system
- compliance with East European standards
- free choice between a classic IEC/DIN series and a progressive series based on the mounting dimensions and motor sizes of IEC 60072
- facility to incorporate components such as encoders, tachogenerators, brakes, speed monitors or forced ventilation units to solve the customer's individual control tasks.

Environment-friendly power generation, the use of renewable energy sources and increased energy awareness are factors which create new challenges for manufacturers of asynchronous motors. In response to the corresponding market trends, VEM has taken steps to achieve compliance with energy efficiency classification IE3 across the whole range of standard motors. Motors for other energy efficiency classes, such as IE2 or IE1, remain available in accordance with the exceptions defined in the European Commission regulations (EC) No. 640/2009 and (EU) No. 4/2014 or else the local regulations of the intended markets (see also the section "International efficiency classification" in Chapter 1).

VEM has remained true to its proven concept of grey cast iron housings for the new standard motor series. This robust, low-vibration construction permits use in the most varied applications. The range of modular built-on accessories has also been extended continuously over the past years, guaranteeing fast deliveries and universal modification options for standard motors. For optimum motor efficiency, the mid-size range incorporates copper die cast rotors manufactured on the basis of the very latest production technologies.

The mounting dimensions of all efficiency classes correspond to those defined in IEC 60072-1 and EN 50347.

Motor design

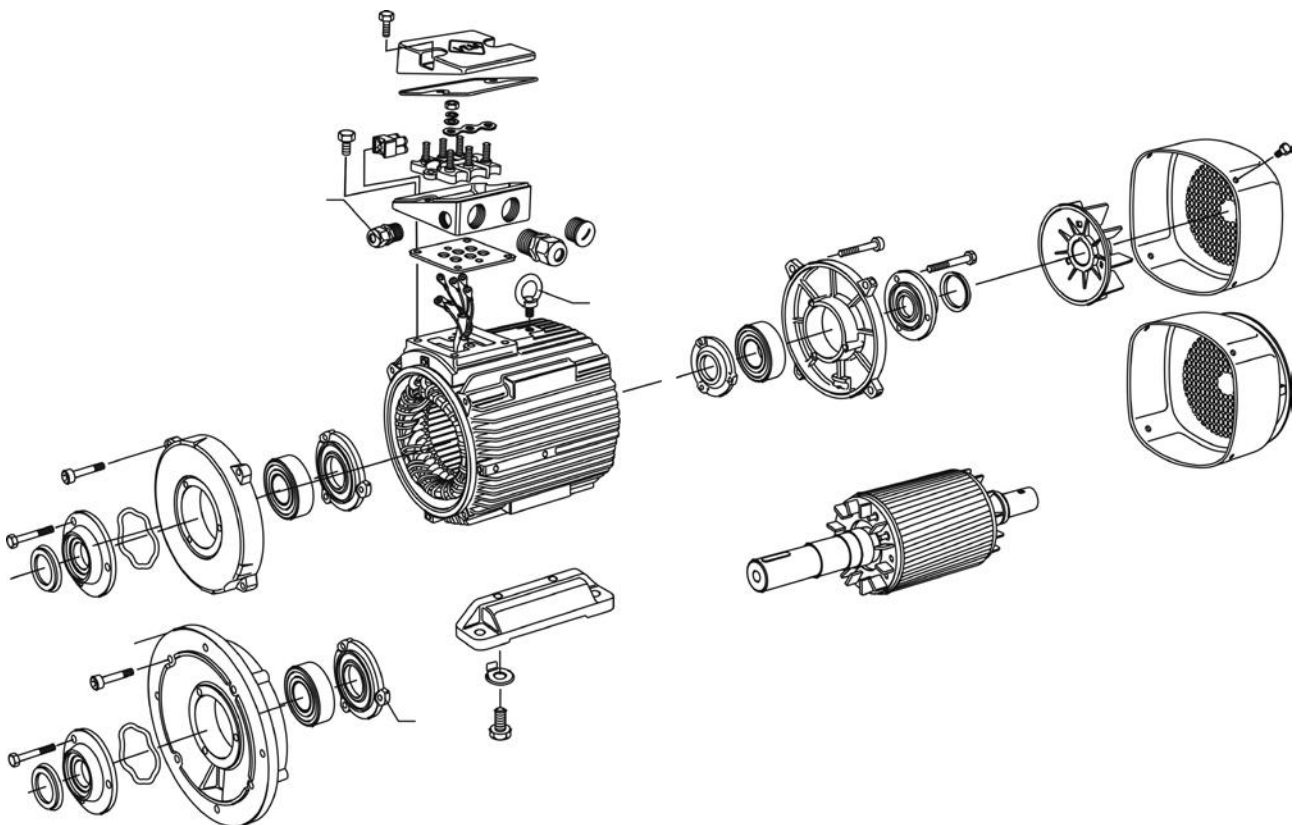

Figure: Design of a VEM standard motor

Motors comprise the following main components:

- Stator housing with laminated core and winding
- End shields with bearings
- Die-cast rotor (aluminium or copper)
- Fan with fan cowl
- Terminal box

The motor space is defined by the housing, the two end shields, the outer bearing cover, the shaft seal and the terminal box gasket. Stator housings – as already

described – are always manufactured in grey cast iron, with radially or horizontally/vertically arranged cooling ribs. A flange surface with a corresponding opening to the housing inner is cast-on for mounting of the terminal box and terminal base. The flange surface is covered by the terminal box gasket. The terminal box can be arranged on the right, on the left or on the top.

Cooling and ventilation

The motors are fitted with radial fans made from plastic or cast aluminium alloy, which provide cooling independently of the running direction of the motor (IC 411 to IEC/EN 60034-6). If requested by the customer, 2-pole motors with smaller shaft heights can also be provided with a low-noise, direction-dependent fan. In size 355, 2-pole motors are supplied with direction-dependent fans as standard.

When installing the motors, a minimum clearance between the fan cowl and the wall (dimension B1) must be observed to ensure correct cooling. Fan cowls are manufactured either in sheet steel or – in the mid-size range – in dimensionally stable, impact-resistant plastic, which enables construction of an especially quiet-running motor version.

Type/Size	Material			
	Fan		Fan cowl	
	Standard	Special version ¹⁾	Standard	Special version ¹⁾
K.../ W... 56-132	Plastic	Cast aluminium	Sheet steel	-
K.../ W... 132-225	Plastic	Cast aluminium	Plastic	Sheet steel
K.../ W... 250-315	Plastic	Cast aluminium	Sheet steel	-
K.../ W... 355	Cast aluminium	-	Sheet steel	-

¹⁾ Possible at extra charge, upon request

Pole-changing motors

Pole-changing motors are incorporated into drives with either constant or quadratically increasing load torque, as appropriate to the load torque behaviour of the driven machine. The different characteristics are distinguished accordingly in the selection tables. Motors are designed for a single rated voltage, e.g. 230 V, 400 V or 690 V, and are intended for direct starting via the pole sequence. Versions for 60 Hz frequency or special voltages in accordance with IEC 60038 are possible.

Pole-changing is realised with

- two separate windings (two speeds)
- one winding with Dahlander connection (two speeds)
- two separate windings, one with Dahlander connection (three speeds)
- two separate windings, both with Dahlander connection (four speeds)

While a winding with Dahlander connection can only achieve a speed ratio of 1:2, the option of two separate windings enables the realisation of further speed stages, albeit with lower outputs compared to the corresponding basic version. Single windings are configured with star (Y) or delta (Δ) connection, Dahlander windings with Δ/YY or Y/YY connection.

The applicable assignments between connection configurations and numbers of poles are indicated in the motor selection data. Star-delta starting can be realised for the largest pole number (slowest speed) if the operating connection is Δ. In case of two separate windings with at least one Δ connection, the non-live Δ connection must be opened.

Efficiency specifications

For all classified series with designations starting "IE.-", energy efficiency is determined in accordance with IEC/EN 60034-2-1. The motor efficiencies satisfy at least the respective limit values specified in IEC/EN 60034-30-1.

Fields of application

Thanks to the multitude of available options, VEM standard motors can be used in all fields and branches of industry. They are suitable for use both in demanding environments, such as those of the chemical and petrochemical industry, and under practically all climatic conditions, including offshore applications. The wide mains voltage range permits worldwide use.

In addition to general mechanical engineering, applications are to be found in the following fields, among many others:

- Fans
- Pumps
- Compressors
- Conveyors, cranes and hoists
- Packaging machines
- Automation and drive systems
- Manufacturing industry
- Pharmaceuticals industry
- Chemical industry
- Print and paper industry
- Process industry

Overview of technical data

The most important technical data are summarised in the following table.
Further information can be taken from the catalogue section "Introduction" (Chapter 1).

Product group	Squirrel-cage rotor, IEC/DIN
Rated output	0.06 kW to 500 kW (IE1-, IE2-, IE3-versions with 2, 4, 6 and 8 poles)
Sizes	56 to 355
Efficiency classification/ efficiency determination	IEC/EN 60034-30-1 / IEC/EN 60034-2-1, ≤ 1 kW direct measurement, > 1 kW residual loss method
Housing material	Grey cast iron
Rated torque	0.4 Nm to 3600 Nm
Method of connection	Single-speed motors are designed in star-delta configuration as standard.
Stator winding insulation	Thermal class 155, optional 155 [F(B)], 180 to IEC/EN 60034-1
Degree of protection	IP 55 to IEC/EN 60034-5, optionally IP 56 or higher
Type of cooling	IC 411, IC 416, IC 71W (IC 31W) to IEC/EN 60034-6
Coolant temperature/ installation altitude	Standard -20 °C to +40 °C, Altitude 1000 m above sea level
Rated voltage	Standard voltages to EN 60038 50 Hz: 230 V, 400 V, 500 V, 690 V, 60 Hz: 275 V, 460 V, 480 V, 600 V Voltage ranges A and B to IEC/EN 60034-1 (230 V, 50 Hz and 275 V, 60 Hz from size 315 prior consultation necessary)
Duty types	S1, continuous duty, Short-time duty S2, 10/30/60 min Duty type S3/S6, 25/40/60 %c.d.f.
Types of construction	IM B3, IM B35, IM B5 and derived types to IEC/EN 60034-7
Paint finish	Normal finish "Moderate", colour RAL 7031, blue-grey Special finish "Worldwide", colour RAL 7031, blue-grey
Vibration severity grade	Grade "A" as standard for machines with no special vibration requirements
Shaft ends	to DIN 748 (IEC 60072), balanced with half-key
Limit speeds	Please refer to the section of "Limit speeds" in catalogue section "Motors for converter-fed operation", Chapter 4.
Bearing design	Please refer to the tables of bearing design data.
Motor mass	Please refer to the technical selection lists.
Terminal boxes	Please refer to the section "Terminal boxes".
Documentation	An operating and maintenance manual, a terminal plan and a safety data sheet are supplied with each motor.
Tolerances	Please refer to the section "Tolerances" in catalogue section "Introduction", Chapter 1.
Options	Please refer to the section "Overview of modifications" in catalogue section "Introduction", Chapter 1.

Motor selection data

Three-phase motors with squirrel-cage rotor, Premium Efficiency IE3

with surface cooling, duty type S1, continuous duty
for rated voltage, thermal class 155 (F), degree of protection IP 55, 50 Hz

Motor selection data													Design point 400 V, 50 Hz		
Type	P _B kW	M _B Nm	n _B rpm	η _B IEC/EN 60034-2-1			cosφ _B -	I _B A	I _A /I _B -	M _A /M _B -	M _S /M _B -	M _K /M _B -	J kgm ²	m kg	
				100 %	75 %	50 %									
				400 V											
Synchronous speed 3000 rpm – 2-pole version															
IE3-W41R 56 G2	0.12	0.4	2830	IE3-	60.8	59.4	55.9	0.77	0.32	4.5	2.1	2.1	2.3	0.00013	4.5
IE3-W42R 63 K2	0.18	0.6	2790	IE3-	65.9	63.1	58.8	0.76	0.51	4.1	1.9	1.9	2.2	0.00013	4.9
IE3-W41R 63 G2	0.25	0.9	2825	IE3-	69.7	70.1	67.1	0.83	0.58	4.9	2.4	2.2	2.7	0.00025	6.3
IE3-W42R 71 K2	0.37	1.2	2840	IE3-	73.8	74.1	71.7	0.82	0.83	5.8	2.8	2.7	3.2	0.00032	7.6
IE3-W41R 71 GY2	0.55	1.8	2870	IE3-	77.8	77.5	74.4	0.79	1.23	6.3	2.9	2.9	3.5	0.00057	10
IE3-W42R 80 K2	0.75	2.50	2870	IE3-	80.7	80.7	78.2	0.81	1.65	6.4	2.6	2.6	3.5	0.00072	11.5
IE3-W41R 80 GY2	1.1	3.66	2870	IE3-	82.7	83.8	82.6	0.86	2.22	7.0	2.8	2.7	3.4	0.00132	15
IE3-W42R 90 S2	1.5	4.94	2900	IE3-	84.2	85.4	83.2	0.81	3.12	7.9	3.5	3.5	4.4	0.0017	19
IE3-W41R 90 LY2	2.2	7.30	2880	IE3-	85.9	85.7	83.9	0.88	4.25	8.0	2.5	2.3	2.9	0.00275	23.5
IE3-W41R 100 LY2	3	9.81	2920	IE3-	87.1	88	86.3	0.82	6.0	7.7	2.3	2.2	3.5	0.0045	31
IE3-W41R 112 MY2	4	13.10	2920	IE3-	88.1	87.5	86.9	0.84	7.9	8.3	2.3	2.1	3.3	0.0055	38
IE3-W41R 132 S2T	5.5	18.0	2925	IE3-	89.2	89.4	87.7	0.80	11.1	8.3	2.6	2.5	3.8	0.0068	48
IE3-W41R 132 SX2	7.5	24.0	2925	IE3-	90.1	89.4	87.9	0.87	14.0	8.0	2.5	2.1	3.3	0.0168	75
IE3-W41R 160 M2	11	36.0	2950	IE3-	91.4	91.7	90.5	0.90	19.5	8.0	2.2	1.8	3.2	0.0575	125
IE3-W41R 160 MX2	15	49.0	2950	IE3-	91.9	92.0	91.3	0.91	26.0	7.9	2.2	1.7	3.1	0.0675	145
IE3-W41R 160 L2	18.5	60.0	2960	IE3-	92.4	92.5	91.4	0.90	32.0	9.2	2.6	2.1	3.6	0.078	160
IE3-W41R 180 M2C	22	71	2975	IE3-	92.7	92.6	91.5	0.91	37.5	8.9	1.9	1.4	3.3	0.1717	214
IE3-W41R 200 L2	30	97	2965	IE3-	93.3	92.2	90.6	0.88	52.5	8.6	2.1	1.6	3.3	0.36	305
IE3-W41R 200 LX2C	37	119	2980	IE3-	93.7	92.9	91.7	0.89	64.0	8.7	1.7	1.3	3.2	0.4757	310
IE3-W41R 225 M2	45	145	2960	IE3-	94.0	93.7	93.0	0.89	77.5	8.8	2.3	1.9	3.2	0.375	375
IE3-W41R 250 M2	55	177	2970	IE3-	94.6	94.4	93.6	0.91	92	8.9	2.2	1.9	3.2	0.65	510
IE3-W41R 280 S2	75	241	2967	IE3-	94.7	94.5	93.9	0.89	128	8.1	1.9	1.9	2.8	0.65	500
IE3-W41R 280 M2	90	289	2970	IE3-	95	94.5	94	0.90	152	8.4	2.2	1.9	3.1	0.675	545
IE3-W41R 315 S2	110	354	2970	IE3-	95.2	94.5	93.5	0.89	187	10.0	1.9	1.7	3.0	1.21	750
IE3-W41R 315 M2	132	423	2980	IE3-	95.4	95.0	94.5	0.89	224	10.0	2.0	1.8	3.0	1.44	815
IE3-W41R 315 MX2	160	513	2980	IE3-	95.7	95.7	95.0	0.9	268	8.5	2.3	1.7	2.6	2.37	1095
IE3-W41R 315 MY2	200	641	2980	IE3-	95.8	95.9	95.5	0.91	331	8.3	2.6	1.6	2.4	2.82	1200
IE3-W41R 315 L2	250	800	2985	IE3-	96.0	96.0	95.9	0.92	409	8.4	2.5	1.4	2.3	3.66	1460
IE3-W41R 315 LX2	315	1008	2985	IE3-	95.8	95.8	95.8	0.92	516	8.5	2.8	1.6	2.5	4.43	1700

Size 355/400: See Chapter 3 „Transnorm motors“.

Three-phase motors with squirrel-cage rotor, Premium Efficiency IE3

with surface cooling, duty type S1, continuous duty
for rated voltage, thermal class 155 (F), degree of protection IP 55, 50 Hz

Motor selection data													Design point 400 V, 50 Hz		
Type	P _B kW	M _B Nm	n _B rpm	η _B IEC/EN 60034-2-1			cosφ _B -	I _B A	I _A /I _B -	M _A /M _B -	M _S /M _B -	M _K /M _B -	J kgm ²	m kg	
				100 %	75 %	50 %									
				400 V											
Synchronous speed 1500 rpm – 4-pole version															
IE3-W42R 63 K4	0.12	0.8	1365	IE3-	64.8	64.5	59.7	0.72	0.37	3.2	1.9	1.8	2.2	0.00024	5.2
IE3-W41R 63 G4	0.18	1.2	1415	IE3-	69.9	67.2	61.2	0.67	0.55	4.4	1.8	1.8	2.7	0.0005	7.1
IE3-W42R 71 K4	0.25	1.7	1395	IE3-	73.5	71.2	66.7	0.70	0.72	3.9	2.1	2.1	2.5	0.0005	7.8
IE3-W41R 71 GY4	0.37	2.5	1425	IE3-	77.3	76.8	73	0.69	1	4.9	2.4	2.4	3	0.00087	9.9
IE3-W41R 80 K4	0.55	3.7	1430	IE3-	80.8	81	80.1	0.80	1.25	6	2.4	2.3	2.7	0.00207	14.5
IE3-W41R 80 G4	0.75	4.96	1445	IE3-	82.5	82.3	79.6	0.77	1.70	7.0	3.1	3.1	3.7	0.0026	17.0
IE3-W41R 90 SY4	1.1	7.30	1440	IE3-	84.1	82.6	79.7	0.76	2.5	6.7	2.8	2.7	3.7	0.004	22.5
IE3-W41R 90 L4	1.5	9.91	1445	IE3-	85.3	83.2	80.7	0.77	3.35	7.2	3.2	3.0	3.5	0.0045	28
IE3-W41R 100 LY4	2.2	14.4	1455	IE3-	86.7	85.2	81.7	0.77	4.80	9.3	3.2	3.0	3.6	0.009	36
IE3-W41R 100 LX4	3	19.7	1455	IE3-	87.7	86.3	84.5	0.77	6.50	9.0	3.3	3.1	3.9	0.011	45
IE3-W41R 112 MW4	4	26	1460	IE3-	88.6	87.9	86.2	0.85	8.0	8.7	2.6	2.4	4.1	0.017	56
IE3-W41R 132 S4	5.5	35	1480	IE3-	91.0	90.2	87.8	0.73	12.0	9.9	3.4	2.8	5.4	0.035	90
IE3-W41R 160 M4	11	71	1475	IE3-	91.4	91.5	90.5	0.83	21.0	7.5	2.5	2.0	3.2	0.078	125
IE3-W41R 160 L4C	15	96	1490	IE3-	92.8	92.5	91.0	0.83	28.0	10.5	2.8	2.4	3.9	0.1567	175
IE3-W41R 180 M4	18.5	120	1475	IE3-	92.7	92.9	92.0	0.84	34.5	6.9	1.9	1.7	3.0	0.168	210
IE3-W41R 180 L4	22	142	1480	IE3-	93.0	93.0	92.1	0.84	40.5	7.6	2.2	2.0	3.2	0.203	240
IE3-W41R 200 L4C	30	193	1485	IE3-	93.6	92.4	92.4	0.85	54.5	7.0	1.6	1.4	2.6	0.411	327
IE3-W41R 225 S4C	37	237	1490	IE3-	93.9	93.8	93.2	0.85	67.0	7.4	1.9	1.4	2.7	0.4675	367
IE3-W41R 225 M4	45	290	1482	IE3-	94.2	94.3	94.0	0.82	84	8.1	2.6	2.1	2.6	0.619	450
IE3-W41R 250 M4	55	354	1485	IE3-	94.7	94.8	94.4	0.83	101	8.1	2.1	1.8	2.5	0.95	550
IE3-W41R 280 S4	75	482	1485	IE3-	95.0	94.6	94.2	0.83	137	8.2	2.1	1.8	2.5	1.1	617
IE3-W41R 280 M4	90	578	1487	IE3-	95.2	94.7	94.0	0.83	164	9.2	2.1	1.9	2.7	1.96	785
IE3-W41R 315 S4	110	706	1487	IE3-	95.4	95.0	94.3	0.82	203	9.5	1.9	1.7	2.7	1.96	760
IE3-W41R 315 M4	132	849	1485	IE3-	95.6	95.4	95.0	0.83	240	9.0	2.2	1.9	2.7	2.27	850
IE3-W41R 315 MX4	160	1026	1490	IE3-	95.8	95.5	95.0	0.84	287	9.5	2.1	2.0	3.2	4.01	1120
IE3-W41R 315 MY4	200	1282	1490	IE3-	96.0	95.8	95.5	0.87	346	9.5	2.1	1.7	2.7	4.82	1250
IE3-W41R 315 L4	250	1602	1490	IE3-	96.2	96.2	96.0	0.87	431	9.4	2.2	1.8	2.7	5.93	1450
IE3-W41R 315 LX4	315	2019	1490	IE3-	96.0	96.0	96.0	0.87	544	9.5	2.3	1.7	2.9	6.82	1630

Size 355/400: See Chapter 3 „Transnorm motors“.

Three-phase motors with squirrel-cage rotor, Premium Efficiency IE3

with surface cooling, duty type S1, continuous duty
for rated voltage, thermal class 155 (F), degree of protection IP 55, 50 Hz

Motor selection data											Design point 400 V, 50 Hz					
Type	P_B	M_B	n_B	IEC/EN 60034-2-1	η_B			$\cos\phi_B$	I_B	I_A/I_B	M_A/M_B	M_S/M_B	M_K/M_B	J	m	
	kW	Nm	rpm		100 %	75 %	50 %	-	400 V	-	-	-	-	kgm ²	kg	
									A							
Synchronous speed 1000 rpm – 6-pole version																
IE3-W41R 63 G6	0.12	1.23	930	IE3-	57.7	60.0	54	0.56	0.5	2.8	1.9	1.8	2.1	0.00045	6.7	
IE3-W42R 71 KY6	0.18	1.89	910	IE3-	63.9	62.0	56.5	0.55	0.75	2.9	1.7	1.7	2.1	0.0006	8.3	
IE3-W41R 71 GY6	0.25	2.54	940	IE3-	68.6	65.3	58.5	0.63	0.84	4	2.2	2.2	2.9	0.0013	10	
IE3-W41R 80 K6	0.37	3.72	950	IE3-	73.5	72.9	69.2	0.7	1.03	4	1.9	1.9	2.4	0.00325	15	
IE3-W41R 80 G6	0.55	5.53	950	IE3-	77.2	75.9	72.4	0.69	1.5	4.1	2.1	2.1	2.5	0.00425	18	
IE3-W41R 90 SY6	0.75	7.50	955	IE3-	78.9	78.3	75.1	0.71	1.95	4.9	2.4	2.3	2.6	0.00625	24	
IE3-W41R 90 L6	1.1	11.00	955	IE3-	81.0	81.0	78.5	0.72	2.75	5.4	2.5	2.4	2.8	0.0072	30	
IE3-W41R 100 LX6	1.5	15.00	955	IE3-	82.5	83.5	81.5	0.76	3.45	5.9	2.3	2.2	2.8	0.0139	36	
IE3-W41R 112 MV6	2.2	22.00	955	IE3-	84.3	83.6	80.9	0.74	5.15	5.7	2.4	2.3	2.9	0.0155	48	
IE3-W41R 132 S6	3	30.0	965	IE3-	86.3	86.7	85.6	0.82	6.1	6.2	2.0	1.3	3.1	0.029	70	
IE3-W41R 132 M6	4	40.0	965	IE3-	86.8	87.0	86.0	0.80	8.3	4.8	1.7	1.4	2.4	0.043	75	
IE3-W41R 132 MX6	5.5	54.0	970	IE3-	88.6	88.6	87.2	0.80	11.0	6.0	2.1	1.7	3.0	0.053	105	
IE3-W41R 160 M6	7.5	73.0	980	IE3-	90.2	90.0	88.3	0.83	14.5	6.4	2.4	2.0	3.0	0.145	145	
IE3-W41R 160 L6C	11	107.0	985	IE3-	91.4	91.2	89.8	0.85	20.5	6.8	2.2	2	2.8	0.166	168	
IE3-W41R 180 L6C	15	145.0	985	IE3-	91.2	91.3	90.2	0.87	27.5	6.8	2	1.7	2.7	0.3396	214	
IE3-W41R 200 L6	18.5	180.0	980	IE3-	91.8	91.7	90.5	0.87	33.5	7.2	2.3	2	3	0.514	310	
IE3-W41R 200 LX6C	22	213.0	985	IE3-	92.2	91.5	90	0.87	39.5	7.6	2.1	1.7	2.9	0.6476	321	
IE3-W41R 225 M6	30	291	984	IE3-	92.9	92.2	91.0	0.84	55.5	7.2	2.7	2.2	2.9	0.92	400	
IE3-W41R 250 M6	37	359	985	IE3-	93.3	93.2	92.3	0.86	66.5	7.1	2.8	2.0	2.7	1.48	545	
IE3-W41R 280 S6	45	434	990	IE3-	93.7	93.5	91.5	0.86	80.5	8.5	2.1	1.8	2.8	2.63	695	
IE3-W41R 280 M6	55	531	990	IE3-	94.2	94.1	93.1	0.85	99	9.0	2.2	1.9	3.1	3.33	815	
IE3-W41R 315 S6	75	723	990	IE3-	94.6	94.0	93.5	0.86	133	8.2	1.8	1.4	2.3	5.55	1060	
IE3-W41R 315 M6	90	868	990	IE3-	94.9	94.0	93.0	0.86	159	8.5	2.2	1.7	2.8	6	1100	
IE3-W41R 315 MX6	110	1.061	990	IE3-	95.1	95.0	94.5	0.86	194	8.5	2.5	1.7	2.7	6.67	1210	
IE3-W41R 315 L6	132	1.267	995	IE3-	95.4	95.0	94.5	0.87	230	9.0	2.8	2.0	3.2	8.6	1550	

Size 355/400: See Chapter 3 „Transnorm motors“.

Three-phase motors with squirrel-cage rotor, Premium Efficiency IE3

with surface cooling, duty type S1, continuous duty
for rated voltage, thermal class 155 (F), degree of protection IP 55, 50 Hz

Motor selection data												Design point 400 V, 50 Hz			
Type	P_B	M_B	n_B	IEC/EN 60034-2-1	η_B			$\cos\phi_B$	I_B	I_A/I_B	M_A/M_B	M_S/M_B	M_K/M_B	J	m
	kW	Nm	rpm		100 %	75 %	50 %	-	400 V	-	-	-	-	kgm ²	kg
									A						
Synchronous speed 750 rpm – 8-pole version															
IE3-W41R 71 G8	0.12	1.67	685	IE3-	50.7	48.8	43	0.64	0.48	2.6	1.7	1.7	2	0.0013	9.9
IE3-W42R 80 K8	0.18	2.53	680	IE3-	58.7	56.3	49.8	0.61	0.73	2.6	1.6	1.6	2	0.00175	12
IE3-W41R 80 G8	0.25	3.39	705	IE3-	64.1	64.3	58.4	0.59	0.93	3	1.4	1.4	2.1	0.003	14
IE3-W42R 90 SY8	0.37	5.01	705	IE3-	69.3	67	61.2	0.56	1.39	3.1	1.6	1.6	2.2	0.00375	18.5
IE3-W41R 90 L8	0.55	7.50	700	IE3-	73.0	70.6	66.3	0.64	1.72	3.6	1.8	1.8	2.3	0.0072	26
IE3-W41R 100 LY8	0.75	10.1	710	IE3-	75.0	74.1	70.0	0.64	2.21	4.2	2.0	2.0	2.7	0.009	28
IE3-W41R 100 LW8	1.1	14.69	715	IE3-	77.7	76.8	73	0.66	3.09	4.7	2.3	2.3	3	0.009	35
IE3-W41R 112 M8	1.5	20.5	700	IE3-	79.7	78.7	76	0.65	4.25	3.8	1.6	1.5	2.1	0.0155	48
IE3-W42R 132 S8	2.2	29.2	720	IE3-	81.9	81.8	78.6	0.67	5.75	5.3	2.3	2.2	3.2	0.023	55
IE3-W41R 132 M8	3	40	720	IE3-	83.5	83.5	81.4	0.72	7	3.9	1.6	1.4	2.1	0.043	74
IE3-W41R 160 M8	4	52	735	IE3-	87	86.7	83.8	0.71	9.4	5.4	2.5	2.2	2.9	0.113	119
IE3-W41R 160 MX8	5.5	72	730	IE3-	87.5	87.5	85.6	0.73	12.5	4.7	1.9	1.7	2.5	0.145	143
IE3-W41R 160 L8	7.5	98	733	IE3-	87.9	87.6	85.6	0.73	17	5.1	2.1	1.8	2.7	0.166	155
IE3-W41R 180 L8	11	145	725	IE3-	89.3	89	87.1	0.75	23.5	5.4	2.1	1.9	2.8	0.228	175
IE3-W41R 200 L8	15	196	730	IE3-	89.6	90	89	0.80	30	5.3	1.8	1.7	2.5	0.324	235
IE3-W41R 225 S8	18.5	240	735	IE3-	90.1									0.514	310
IE3-W41R 225 M8	22	286	735	IE3-	91.5	91.6	90.6	0.79	44	5.7	2.3	2	2.5	0.825	360
IE3-W41R 250 M8	30	391	732	IE3-	91.3	91.9	91.4	0.81	58.5	5.4	2	1.8	2.3	0.92	420
IE3-W41R 280 S8	37	479	738	IE3-	92	92	90.8	0.78	74.5	5.9	2.3	1.8	2.4	1.55	555
IE3-W41R 280 M8	45	581	740	IE3-	93	93	92.4	0.78	89.5	6.5	1.7	1.5	2.4	2.63	700
IE3-W41R 315 S8	55	707	743	IE3-	93.3	93.3	92.4	0.78	109	7.0	1.9	1.7	2.5	3.33	805
IE3-W41R 315 M8	75	965	742	IE3-	93.8	94.2	93.8	0.81	142	7.0	1.9	1.7	2.3	5.55	1120
IE3-W41R 315 MX8	90	1157	743	IE3-	94.3	94.4	93.6	0.8	172	7.9	2.4	2.0	2.7	6	1185
IE3-W41R 315 MY8	110	1419	740	IE3-	93.8	94.0	93.8	0.82	206	6.5	1.9	1.5	2.1	6.76	1250
IE3-W41R 315 L8	132	1703	740	IE3-	94.2	94.2	93.5	0.8	253	8.0	2.4	1.9	2.7	8.71	1450

Size 355/400: See Chapter 3 „Transnorm motors“.

Three-phase motors with squirrel-cage rotor, Premium Efficiency IE3

with surface cooling, duty type S1, continuous duty
for rated voltage, thermal class 155 (F), degree of protection IP 55, 50/60 Hz

Motor selection data														Design point 400 V, 50 Hz 460 V, 60 Hz			
Type	U_B	f_B	P_B	M_B	n_B	η_B			$\cos\phi_B$	I_B	I_A/I_B	M_A/M_B	M_S/M_B	M_K/M_B	J	m	
	V	Hz	kW	Nm	rpm	IEC/EN 60034-2-1 100 % 75 % 50 %			-	A	-	-	-	-	kgm ²	kg	
Synchronous speed 3000 rpm/3600 rpm – 2-pole version																	
IE3-W41R 56 G2	400	50	0.12	0.4	2830	IE3-	60.8	59.4	55.9	0.77	0.32	4.5	2.1	2.1	2.3	0.00013	4.5
	460	60	0.14	0.39	3410	IE3-	71.4	62	66.5	0.82	0.3	5.2	2	2	2.3		
IE3-W42R 63 K2	400	50	0.18	0.62	2790	IE3-	65.9	63.1	58.8	0.76	0.51	4.1	1.9	1.9	2.2	0.00013	4.9
	460	60	0.21	0.59	3400	IE3-	65.9	63.1	58.8	0.76	0.51	4.7	2.4	2.4	2.7		
IE3-W41R 63 G2	400	50	0.25	0.85	2825	IE3-	69.7	70.1	67.1	0.83	0.58	4.9	2.4	2.2	2.7	0.00025	6.3
	460	60	0.3	0.84	3410	IE3-	69.5	70	67.8	0.84	0.58	5.3	2.3	2.2	2.8		
IE3-W42R 71 K2	400	50	0.37	1.24	2840	IE3-	73.8	74.1	71.7	0.82	0.83	5.8	2.8	2.7	3.2	0.00032	7.6
	460	60	0.44	1.23	3430	IE3-	73.4	73.6	71.3	0.84	0.83	6.2	2.9	2.8	3.4		
IE3-W41R 71 GY2	400	50	0.55	1.83	2870	IE3-	77.8	77.5	74.4	0.79	1.23	6.3	2.9	2.9	3.5	0.00057	10
	460	60	0.65	1.79	3460	IE3-	77.0	76.7	73.9	0.81	1.2	6.9	2.9	2.9	3.6		
IE3-W42R 80 K2	400	50	0.75	2.5	2870	IE3-	80.7	80.7	78.2	0.81	1.65	6.4	2.6	2.6	3.5	0.00072	11.5
	460	60	0.9	2.48	3460	IE3-	77.0	76.9	74.7	0.83	1.65	6.9	2.7	2.7	3.6		
IE3-W41R 80 GY2	400	50	1.1	3.66	2870	IE3-	82.7	83.8	82.6	0.86	2.22	7.0	2.8	2.7	3.4	0.00132	15
	460	60	1.3	3.58	3465	IE3-	85.5	85.9	84.6	0.86	2.25	7.3	2.7	2.5	3.5		
IE3-W42R 90 S2	400	50	1.5	4.94	2900	IE3-	84.2	85.4	83.2	0.81	3.12	7.9	3.5	3.5	4.4	0.0017	19
	460	60	1.8	4.93	3490	IE3-	85.5	85.5	83.5	0.83	3.15	8.4	3.3	3.3	4.2		
IE3-W41R 90 LY2	400	50	2.2	7.3	2880	IE3-	85.9	85.7	83.9	0.88	4.25	8.0	2.5	2.3	2.9	0.00275	23.5
	460	60	2.6	7.16	3470	IE3-	86.5	87.2	88.1	0.88	4.3	7.2	2.1	1.8	2.7		
IE3-W41R 100 LY2	400	50	3	9.81	2920	IE3-	87.1	88	86.3	0.82	6	7.7	2.3	2.2	3.5	0.0045	31
	460	60	3.6	9.79	3510	IE3-	88.5	88.8	87.3	0.85	6	6.9	1.9	1.5	3		
IE3-W41R 112 MY2	400	50	4	13.1	2920	IE3-	88.1	87.5	86.9	0.84	7.9	8.3	2.3	2.1	3.3	0.0055	38
	460	60	4.8	13.06	3510	IE3-	89.5	89.9	89.2	0.86	7.8	7.1	1.6	1.4	2.7		
IE3-W41R 132 S2T	400	50	5.5	18	2925	IE3-	89.2	89.4	87.7	0.80	11.1	8.3	2.6	2.5	3.8	0.0068	48
	460	60	6.6	17.91	3520	IE3-	90.2	90.2	88.8	0.83	11.1	7.6	1.9	1.7	3.3		
IE3-W41R 132 SX2	400	50	7.5	24.0	2925	IE3-	90.1	89.4	87.9	0.87	14.0	8.0	2.5	2.1	3.3	0.0168	75
	460	60	9	24	3520	IE3-	90.5	89.5	87.8	0.89	14	7.1	2.3	1.9	3.1		
IE3-W41R 160 M2	400	50	11	36.0	2950	IE3-	91.4	91.7	90.5	0.90	19.5	8.0	2.2	1.8	3.2	0.0575	125
	460	60	13.2	36	3540	IE3-	91	90	87.9	0.91	20	7.3	2	1.6	2		
IE3-W41R 160 MX2	400	50	15	49.0	2950	IE3-	91.9	92.0	91.3	0.91	26.0	7.9	2.2	1.7	3.1	0.0675	145
	460	60	18	48	3545	IE3-	92	92.3	91.2	0.92	26.5	7.4	2	1.6	2.9		
IE3-W41R 160 L2	400	50	18.5	60.0	2960	IE3-	92.4	92.5	91.4	0.90	32.0	9.2	2.6	2.1	3.6	0.078	160
	460	60	22	59	3550	IE3-	92	91.9	90.7	0.91	33	8.5	2.4	1.9	3.3		
IE3-W41R 180 M2C	400	50	22	71	2975	IE3-	92.7	92.6	91.5	0.91	37.5	8.9	1.9	1.4	3.3	0.1717	214
	460	60	26	70	3570	IE3-	92.4	92.0	90.7	0.92	38.5	8.2	1.8	1.3	3.0		
IE3-W41R 200 L2	400	50	30	97	2965	IE3-	93.3	92.2	90.6	0.88	52.5	8.6	2.1	1.6	3.3	0.36	305
	460	60	33	88	3565	IE3-	92.4	91.0	88.6	0.88	51.0	8.5	2.1	1.6	3.2		
IE3-W41R 200 LX2C	400	50	37	119	2980	IE3-	93.7	92.9	91.7	0.89	64.0	8.7	1.7	1.3	3.2	0.4757	310
	460	60	40	107	3575	IE3-	93	91.7	89.5	0.89	60.5	8.8	1.8	1.3	3.2		
IE3-W41R 225 M2	400	50	45	145	2960	IE3-	94.0	93.7	93.0	0.89	77.5	8.8	2.3	1.9	3.2	0.375	375
	460	60	54	145	3553	IE3-	93.6	93.3	92.6	0.89	81.5	8.1	2.1	1.7	2.9		
IE3-W41R 250 M2	400	50	55	177	2970	IE3-	94.6	94.4	93.6	0.91	92	8.9	2.2	1.9	3.2	0.65	510
	460	60	66	177	3568	IE3-	94.1	93.5	92.3	0.92	95.5	8.2	2	1.8	2.9		
IE3-W41R 280 S2	400	50	75	241	2967	IE3-	94.7	94.5	93.9	0.89	128	8.1	1.9	1.9	2.8	0.65	500
	460	60	82	220	3566	IE3-	94.5	94	92.5	0.90	121	8.1	2	1.8	3		
IE3-W41R 280 M2	400	50	90	289	2970	IE3-	95	94.5	94	0.90	152	8.4	2.2		3.1	0.675	545
	460	60	90							upon request							
IE3-W41R 315 S2	400	50	110	354	2970	IE3-	95.2	94.5	93.5	0.89	187	10.0	1.9	1.7	3.0	1.21	750
	460	60	110	294	3570	IE3-	95.0	94.0	92.5	0.89	163	10	2	1.8	3.2		
IE3-W41R 315 M2	400	50	132	423	2980	IE3-	95.4	95.0	94.5	0.89	224	10.0	2.0	1.8	3.0	1.44	815
	460	60	145	387	3580	IE3-	95.4	95.0	94.5	0.89	214	10	2	1.8	3		
IE3-W41R 315 MX2	400	50	160	513	2980	IE3-	95.7	95.7	95.0	0.9	268	8.5	2.3	1.7	2.6	2.37	1095
	460	60	165	440	3585	IE3-	95.4	95	94	0.89	244	9	2.5	1.8	2.8		
IE3-W41R 315 MY2	400	50	200	641	2980	IE3-	95.8	95.9	95.5	0.91	331	8.3	2.6	1.6	2.4	2.82	1200
	460	60	220	587	3580	IE3-	95.8	95.3	94.5	0.91	317	8.5	2.8	1.7	2.7		
IE3-W41R 315 L2	400	50	250	800	2985	IE3-	96.0	96.0	95.9	0.92	409	8.4	2.5	1.4	2.3	3.66	1460
	460	60	280	747	3580	IE3-	96	96	95.5	0.92	458	8.2	2.5	1.4	2.3		
IE3-W41R 315 LX2	400	50	315	1008	2985	IE3-	95.8	95.8	95.8	0.92	516	8.5	2.8	1.6	2.5	4.43	1700
	460	60	340	906	3585	IE3-	95.8	95.8	95.5	0.92	484	9.1	2.9	1.6	2.5		

Size 355/400: See Chapter 3 „Transnorm motors“.

Three-phase motors with squirrel-cage rotor, Premium Efficiency IE3

with surface cooling, duty type S1, continuous duty
for rated voltage, thermal class 155 (F), degree of protection IP 55, 50/60 Hz

Motor selection data															Design point 400 V, 50 Hz 460 V, 60 Hz		
Type	U _B V	f _B Hz	P _B kW	M _B Nm	n _B rpm	η _B IEC/EN 60034-2-1			cosφ _B -	I _B A	I _N /I _B -	M _N /M _B -	M _S /M _B -	M _K /M _B -	J kgm ²	m kg	
						100 %	75 %	50 %									
Synchronous speed 1000 rpm/1200 rpm – 6-pole version																	
IE3-W41R 63 G6	400	50	0.12	1.23	930	IE3-	57.7	60	54	0.56	0.5	2.8	1.9	1.8	2.1	0.00045	6.7
	460	60	0.14	1.18	1130	IE3-	64.0	62.1	56.2	0.54	0.5	3.1	1.8	1.8	2.2		
IE3-W42R 71 KY6	400	50	0.18	1.89	910	IE3-	63.9	62	56.5	0.55	0.75	2.9	1.7	1.7	2.1	0.0006	8.3
	460	60	0.21	1.81	1105	IE3-	67.5	64.6	59.4	0.55	0.73	2.8	1.5	1.5	1.9		
IE3-W41R 71 GY6	400	50	0.25	2.54	940	IE3-	68.6	65.3	58.5	0.63	0.84	4.0	2.2	2.2	2.9	0.0013	10
	460	60	0.3	2.51	1140	IE3-	71.4	68.4	62.4	0.64	0.84	3.9	2.3	2.3	2.7		
IE3-W41R 80 K6	400	50	0.37	3.72	950	IE3-	73.5	72.9	69.2	0.70	1.03	4.0	1.9	1.9	2.4	0.00325	15
	460	60	0.44	3.67	1145	IE3-	75.3	74.8	71.2	0.70	1.03	4.1	1.8	1.8	2.3		
IE3-W41R 80 G6	400	50	0.55	5.53	950	IE3-	77.2	75.9	72.4	0.69	1.5	4.1	2.1	2.1	2.5	0.00425	18
	460	60	0.45	3.67	1170	IE3-	75.3	75.0	69.4	0.58	1.25	5.1	3.0	3.0	3.6		
IE3-W41R 90 SY6	400	50	0.75	7.5	955	IE3-	78.9	78.3	75.1	0.71	1.95	4.9	2.4	2.3	2.6	0.00625	24
	460	60	0.9	7.47	1150	IE3-	82.5	79.6	76.9	0.72	1.95	5.1	2.3	2.1	2.6		
IE3-W41R 90 L6	400	50	1.1	11	955	IE3-	81	81	78.5	0.72	2.7	5.4	2.5	2.4	2.8	0.0072	30
	460	60	0.92	7.51	1170	IE3-	82.3	80.02	74.53	0.62	2.26	6.8	3.5	3	4.2		
IE3-W41R 100 LX6	400	50	1.5	15	955	IE3-	82.5	83.5	81.5	0.76	3.45	5.9	2.3	2.2	2.8	0.0139	36
	460	60	0.92	7.45	1180	IE3-	82.8	80	79.7	0.57	2.45	7.7	3.6	3.6	5.1		
IE3-W41R 132 M6	400	50	4	40.0	965	IE3-	86.8	87.0	86.0	0.80	8.3	4.8	1.7	1.4	2.4	0.043	75
	460	60	4.5	37	1170	IE3-	89.5	88.7	87.6	0.80	7.9	4.8	1.7	1.5	2.4		
IE3-W41R 132 MX6	400	50	5.5	54.0	970	IE3-	88.6	88.6	87.2	0.80	11.0	6.0	2.1	1.7	3.0	0.053	105
	460	60	5.7	46	1175	IE3-	91	89.8	87.5	0.79	10	6.5	2.2	1.9	3.2		
IE3-W41R 160 M6	400	50	7.5	73.0	980	IE3-	90.2	90.0	88.3	0.83	14.5	6.4	2.4	2.0	3.0	0.145	145
	460	60	9	73	1175	IE3-	91.3	90.6	89	0.85	14.6	6	2.2	1.9	2.8		
IE3-W41R 160 L6C	400	50	11	107.0	985	IE3-	91.4	91.2	89.8	0.85	20.5	6.8	2.2	2	2.8	0.166	168
	460	60	13	105	1185	IE3-	91.7	91.4	90	0.86	20.5	6.5	2.1	1.9	2.6		
IE3-W41R 180 L6C	400	50	15	145.0	985	IE3-	91.2	91.3	90.2	0.87	27.5	6.8	2	1.7	2.7	0.3396	214
	460	60	18.5	149	1185	IE3-	93	91.9	90.5	0.85	29.5	6.2	1.8	1.5	2.5		
IE3-W41R 200 L6	400	50	18.5	180.0	980	IE3-	91.8	91.7	90.5	0.87	33.5	7.2	2.3	2	3	0.514	310
	460	60	22	178	1180	IE3-	93	91.7	90.5	0.87	34	6.7	2.1	1.8	2.8		
IE3-W41R 200 LX6C	400	50	22	213.0	985	IE3-	92.2	91.5	90	0.87	39.5	7.6	2.1	1.7	2.9	0.6476	321
	460	60	22	177	1190	IE3-	93	91.4	89.4	0.87	34	6.5	2.4	1.9	3.2		
IE3-W41R 225 M6	400	50	30	291	984	IE3-	92.9	92.2	91.0	0.84	55.5	7.2	2.7	2.2	2.9	0.92	400
	460	60	30							upon request							
IE3-W41R 250 M6	400	50	37	359	985	IE3-	93.3	93.2	92.3	0.86	66.5	7.1	2.8	2.0	2.7	1.48	545
	460	60	40	322	1185	IE3-	94.1	93.3	92	0.86	62	7.2	2.9	2	2.8		
IE3-W41R 280 S6	400	50	45	434	990	IE3-	93.7	93.5	91.5	0.86	80.5	8.5	2.1	1.8	2.8	2.63	695
	460	60	45							upon request							
IE3-W41R 280 M6	400	50	55	531	990	IE3-	94.2	94.1	93.1	0.85	99	9.0	2.2	1.9	3.1	3.33	815
	460	60	55	440	1195	IE3-	94.5	94	92.5	0.85	86	9.5	2.5	2.2	3.4		
IE3-W41R 315 S6	400	50	75	723	990	IE3-	94.6	94.0	93.5	0.86	133	8.2	1.8	1.4	2.3	5.55	1060
	460	60	85							upon request							
IE3-W41R 315 M6	400	50	90	868	990	IE3-	94.9	94.0	93.0	0.86	159	8.5	2.2	1.7	2.8	6	1100
	460	60	99							upon request							
IE3-W41R 315 MX6	400	50	110	1.061	990	IE3-	95.1	95.0	94.5	0.86	194	8.5	2.5	1.7	2.7	6.67	1210
	460	60	120							upon request							
IE3-W41R 315 L6	400	50	132	1.267	995	IE3-	95.4	95.0	94.5	0.87	230	9.0	2.8	2.0	3.2	8.6	1550
	460	60	132	1055	1195	IE3-	95.8	95.3	94.4	0.84	206	9.5	3	2.2	3.5		

Size 355/400: See Chapter 3 „Transnorm motors“.

Three-phase motors with squirrel-cage rotor, Premium Efficiency IE3

with surface cooling, duty type S1, continuous duty
for rated voltage, thermal class 155 (F), degree of protection IP 55, 50/60 Hz

Motor selection data															Design point 400 V, 50 Hz 460 V, 60 Hz		
Type	U _B	f _B	P _B	M _B	n _B	η _B			cosφ _B	I _B	I _A /I _B	M _A /M _B	M _G /M _B	M _K /M _B	J	m	
						IEC/EN 60034-2-1			400 V								
						100 %	75 %	50 %	-	A	-	-	-	-	kgm ²	kg	
Synchronous speed 750 rpm/900 rpm – 8-pole version																	
IE3-W41R 71 G8	400	50	0.12	1.67	685	IE3-	50.7	48.8	43	0.64	0.48	2.6	1.7	1.7	2	0.0013	9.9
	460	60	0.14	1.59	840	IE3-	59.5	59.1	52.7	0.61	0.47	2.8	1.8	1.8	2.1		
IE3-W42R 80 K8	400	50	0.18	2.53	680	IE3-	58.7	56.3	49.8	0.61	0.73	2.6	1.6	1.6	2	0.00175	12
	460	60	0.21	2.39	840	IE3-	64.0	59	51.1	0.55	0.77	2.9	1.9	1.9	2.4		
IE3-W41R 80 G8	400	50	0.25	3.39	705	IE3-	64.1	64.3	58.4	0.59	0.93	3.0	1.4	1.4	2.1	0.003	14
	460	60	0.3	3.33	860	IE3-	68.0	65.8	59.8	0.55	0.98	3.1	1.3	1.3	2.2		
IE3-W41R 90 S8	400	50	0.37	4.98	710	IE3-	69.3	69	64.4	0.63	1.2	3.6	2.1	2.1	2.3	0.00625	25
	460	60	0.44	4.91	855	IE3-	72	69.3	64.8	0.63	1.22	3.2	1.6	1.6	1.9		
IE3-W41R 100 L8	400	50	0.75	10.0	715	IE3-	75	75.9	71.3	0.63	2.25	4.4	2.5	2.5	2.8	0.0123	33.5
	460	60	0.9	9.95	865	IE3-	75.5	78.8	75.5	0.66	2.12	4.8	2.3	2.3	2.8		
IE3-W41R 100 LW8	400	50	1.1	14.69	715	IE3-	77.7	76.8	73	0.66	3.09	4.7	2.3	2.3	3	0.009	35
	460	60	1.25	13.8	865	IE3-	78.5	77.4	73.5	0.65	2.98	5.1	2.3	2.3	3.2		
IE3-W41R 112 M8	400	50	1.5	20.5	700	IE3-	79.7	78.7	76	0.65	4.25	3.8	1.6	1.5	2.1	0.0155	48
	460	60	1.25	13.72	870	IE3-	80.4	78.3	73.6	0.55	3.7	3.7	2	2	2.9		
IE3-W41R 132 S8	400	50	2.2	29	725	IE3-	84.4	84.5	82.4	0.7	5.4	4.1	1.6	1.5	2.3	0.043	80
	460	60	2.6	28	875	IE3-	85.6	85.7	83.7	0.71	5.4	4.0	1.5	1.4	2.2		
IE3-W41R 132 M8	400	50	3	40	720	IE3-	83.5	83.5	81.4	0.72	7	3.9	1.6	1.4	2.1	0.043	74
	460	60	3							upon request							
IE3-W41R 160 M8	400	50	4	52	735	IE3-	87	86.7	83.8	0.71	9.4	5.4	2.5	2.2	2.9	0.113	119
	460	60	4.8	51	885	IE3-	88.4	87.9	85.4	0.72	9.5	5.1	2.3	2.0	2.6		
IE3-W41R 160 MX8	400	50	5.5	72	730	IE3-	87.5	87.5	85.6	0.73	12.5	4.7	1.9	1.7	2.5	0.145	143
	460	60	5.5							upon request							
IE3-W41R 160 L8	400	50	7.5	98	733	IE3-	87.9	87.6	85.6	0.73	17	5.1	2.1	1.8	2.7	0.166	155
	460	60	7.5							upon request							
IE3-W41R 180 L8	400	50	11	145	725	IE3-	89.3	89	87.1	0.75	23.5	5.4	2.1	1.9	2.8	0.228	175
	460	60	11							upon request							
IE3-W41R 200 L8	400	50	15	196	730	IE3-	89.6	87.6	85.6	0.80	30	5.3	1.8	1.7	2.5	0.324	235
	460	60	18	196	878	IE3-	90.3	90.7	89.7	0.80	31.5	4.9	1.7	1.6	2.3		
IE3-W41R 225 S8	400	50	18.5	240	735	IE3-	90.1								0.514	310	
	460	60	18.5							upon request							
IE3-W41R 225 M8	400	50	22	286	735	IE3-	91.5	91.6	90.6	0.79	44	5.7	2.3	2	2.5	0.825	360
	460	60	22							upon request							
IE3-W41R 250 M8	400	50	30	391	732	IE3-	91.3	91.9	91.4	0.81	58.5	5.4	2	1.8	2.3	0.92	420
	460	60	30							upon request							
IE3-W41R 280 S8	400	50	37	479	738	IE3-	92	92	90.8	0.78	74.5	5.9	2.3	1.8	2.4	1.55	555
	460	60	37							upon request							
IE3-W41R 280 M8	400	50	45	581	740	IE3-	93	93	92.4	0.78	89.5	6.5	1.7	1.5	2.4	2.63	700
	460	60	54	579	890	IE3-	93.6	93	92.4	0.79	91.5	6	1.5	1.3	2.1		
IE3-W41R 315 S8	400	50	55	712	738	IE3-	92	92	90.8	0.78	74.5	5.9	2.3	1.8	2.4	3.33	805
	460	60	55							upon request							
IE3-W41R 315 M8	400	50	75	965	742	IE3-	93.8	94.2	93.8	0.81	142	7.0	1.9	1.7	2.3	5.55	1120
	460	60	75							upon request							
IE3-W41R 315 MX8	400	50	90	1157	743	IE3-	94.3	94.4	93.6	0.8	172	7.9	2.4	2.0	2.7	6	1185
	460	60	108	1152	895	IE3-	94.8	94.7	94.7	0.78	183	8	1.6	1.6	2.6		
IE3-W41R 315 MY8	400	50	110	1419	740	IE3-	93.8	94.0	93.5	0.82	206	6.5	1.9	1.5	2.1	6.76	1250
	460	60	120	1288	890	IE3-	94.2	94.2	94.2	0.82	195	6.6	1.8	1.6	2.2		
IE3-W41R 315 L8	400	50	132	1703	740	IE3-	94.2	94.2	93.5	0.8	253	8.0	2.4	1.9	2.7	8.71	1450
	460	60	132							upon request							

Size 355/400: See Chapter 3 „Transnorm motors“.

Three-phase motors with squirrel-cage rotor, High Efficiency IE2

with surface cooling, duty type S1, continuous duty
for rated voltage, thermal class 155 (F), degree of protection IP 55, 50 Hz



Motor selection data													Design point 400 V, 50 Hz		
Type	P _B kW	M _B Nm	n _B rpm	η _B IEC/EN 60034-2-1			cosφ _B -	I _B 400 V A	I _A /I _B -	M _A /M _B -	M _G /M _B -	M _K /M _B -	J kgm ²	m kg	
				100 %	75 %	50 %									
Synchronous speed 3000 rpm – 2-pole version															
IE2-WE2R 56 G2	0.12	0.40	2830	IE2-	53.6	69.6	60.8	0.77	0.32	4.5	2.1	2.1	2.3	0.00013	4.5
IE2-WE2R 63 K2	0.18	0.62	2790	IE2-	60.4	63.1	57.6	0.76	0.51	4.1	1.9	1.9	2.2	0.00013	4.9
IE2-WE2R 63 G2	0.25	0.86	2775	IE2-	64.8	66.7	61.9	0.8	0.67	4.2	1.9	1.9	2.2	0.00015	5.2
IE2-WE2R 71 K2	0.37	1.28	2750	IE2-	69.5	70.8	69.4	0.84	0.89	4.6	1.8	1.8	2.1	0.00025	6.7
IE2-WE2R 71 G2	0.55	1.89	2775	IE2-	74.1	75.0	72	0.81	1.32	5.1	2.3	2.1	2.6	0.00032	7.6
IE2-WE2R 80 K2	0.75	2.54	2825	IE2-	77.4	77.1	72.9	0.81	1.72	5.9	2.4	2.4	2.4	0.00057	10.7
IE2-WE2R 80 G2	1.1	3.75	2805	IE2-	79.6	78.7	76.4	0.85	2.36	5.6	1.9	1.8	2.2	0.00072	11.5
IE2-WE2R 90 S2	1.5	4.99	2870	IE2-	81.3	82.0	79.4	0.8	3.30	6.6	3.2	3.2	3.7	0.00132	16
IE2-WE2R 90 L2	2.2	7.37	2850	IE2-	83.2	83.0	81.6	0.85	4.55	7.5	2.8	2.3	2.9	0.0017	19.0
IE2-WE2R 100 LY2	3	9.97	2875	IE2-	84.6	85.1	83.6	0.85	6	7.4	2.6	2.3	3.3	0.0045	28.5
IE2-WE1R 112 M2	4	13.20	2900	IE2-	85.8	85.9	84.8	0.81	8.4	7	2.2	2.1	2.9	0.0045	32.0
IE2-WE1R 132 SY2T	5.5	18.20	2890	IE2-	87.0	86.2	86.4	0.84	11	7.2	2.1	1.7	2.8	0.0055	40.0
IE2-WE1R 132 SX2T	7.5	24.90	2880	IE2-	88.1	88.4	87.8	0.84	14.8	6.3	1.5	1.2	2.6	0.0068	48.0
IE2-WE1R 132 SX2	7.5	24.5	2925	IE2-	88.8	89.2	88.3	0.91	13.5	6.7	2.1	1.6	2.9	0.0168	75
IE2-WE1R 160 M2	11.0	35.6	2950	IE2-	90.3	90.3	89.1	0.90	19.5	7.7	2.3	1.7	3.1	0.0258	125
IE2-WE1R 160 MX2	15.0	48.7	2940	IE2-	90.7	90.5	89.1	0.92	26	6.7	1.8	1.4	2.6	0.0675	140
IE2-WE1R 160 L2	18.5	60.2	2935	IE2-	91.0	91.4	91.4	0.91	32	7.2	2.0	1.5	2.8	0.0675	140
IE2-WE1R 180 M2	22	72	2935	IE2-	91.3	90.6	86.4	0.90	38.5	6.2	1.4	1.1	2.4	0.105	173
IE2-WE1R 200 L2	30	97	2945	IE2-	92.0	91.3	90.5	0.91	52	6.9	1.7	1.3	2.6	0.128	210
IE2-WE1R 200 LX2	37	120	2940	IE2-	92.5	92.3	91.6	0.92	63	7.4	1.9	1.4	2.9	0.154	233
IE2-WE2R 200 LX2	37	120	2940	IE2-	92.5	92.3	91.6	0.92	63	7.4	1.9	1.4	2.9	0.154	233
IE2-WE1R 225 M2	45	146	2950	IE2-	92.9	92.2	91.2	0.87	80.5	6.9	1.7	1.1	2.7	0.220	295
IE2-WE1R 250 M2	55	178	2955	IE2-	93.5	93.7	93.2	0.89	95.5	8.2	2.3	1.9	2.8	0.375	385
IE2-WE1R 280 S2	75	241	2970	IE2-	94.1	94.0	91.5	0.90	128	7.9	2.1	1.7	3.0	0.65	500
IE2-WE1R 280 M2	90	289	2970	IE2-	94.4	94.1	91.9	0.91	151	7.7	2.0	1.7	2.8	0.68	550
IE2-WE1R 315 S2	110	353	2975	IE2-	94.5	94.3	93.3	0.89	189	8.0	1.3	1.2	2.4	1.21	730
IE2-WE1R 315 M2	132	424	2975	IE2-	95.0	94.8	94.5	0.89	225	9.2	1.4	1.2	2.4	1.44	820
IE2-WE1R 315 MX2	160	514	2973	IE2-	94.8	94.8	94.8	0.89	274	8.2	1.3	1.3	2.4	1.76	955
IE2-WE1R 315 MY2	200	640	2983	IE2-	95.4	95.0	94.3	0.88	344	9.4	2.8	2.0	3.0	2.82	1200
IE2-WE1R 315 L2	250	800	2984	IE2-	95.4	95.4	95.4	0.92	411	9.0	2.3	1.2	2.3	3.66	1450
IE2-WE1R 315 LX2	315	1008	2985	IE2-	95.4	95.4	95.0	0.92	518	8.5	2.8	1.6	2.5	4.43	1700
IE2-WE2R 355 M2	355	1136	2985	IE2-	95.5	95.5	95.5	0.92	583	7.7	1.3	1.0	2.6	4.20	2000
IE2-WE2R 355 MX2	400	1278	2990	IE2-	95.5	95.5	95.5	0.91	664	9.4	1.8	1.0	3.0	4.50	2200
IE2-WE2R 355 LY2	450	1440	2985	IE2-	95.5	95.5	95.5	0.92	739	7.0	1.3	0.9	2.4	7.10	2400
IE2-WE2R 355 L2	500	1597	2990	IE2-	95.5	95.5	95.5	0.92	821	8.5	1.5	1.2	2.5	7.10	2400

Three-phase motors with squirrel-cage rotor, High Efficiency IE2

with surface cooling, duty type S1, continuous duty
for rated voltage, thermal class 155 (F), degree of protection IP 55, 50 Hz

IE2 | EU REGULATION 640/2009
USE WITH VARIABLE
SPEED DRIVE ONLY!

Motor selection data													Design point 400 V, 50 Hz		
Type	P_B	M_B	n_B	η_B			$\cos\phi_B$	I_B	I_A/I_B	M_A/M_B	M_S/M_B	M_K/M_B	J	m	
				IEC/EN 60034-2-1				400 V							
	kW	Nm	rpm	100 %	75 %	50 %	-	A	-	-	-	-	kgm ²	kg	
Synchronous speed 1500 rpm – 4-pole version															
IE2-WE2R 63 K4	0.12	0.83	1380	IE2-	59.1	55.7	46.8	0.69	0.45	2.8	1.6	1.6	2.1	0.00019	4.8
IE2-WE1R 63 GY4	0.18	1.23	1395	IE2-	64.7	66.3	61.3	0.72	0.54	3.5	1.7	1.7	2.2	0.0004	6.3
IE2-WE2R 71 K4	0.25	1.71	1395	IE2-	68.5	68.1	63.8	0.70	0.73	3.9	2.1	2.1	2.5	0.0005	7.8
IE2-WE1R 71 GY4	0.37	2.48	1425	IE2-	72.7	72.2	68.6	0.69	1.00	4.9	2.4	2.4	3.0	0.00087	9.9
IE2-WE2R 80 K4	0.55	3.71	1415	IE2-	77.1	77.1	73.9	0.72	1.42	4.9	2.6	2.5	2.8	0.00107	11.7
IE2-WE1R 80 GY4	0.75	5.01	1430	IE2-	79.6	78.0	74.7	0.80	1.73	5.7	2.2	2.2	3.1	0.00207	14.5
IE2-WE2R 90 S4	1.1	7.32	1435	IE2-	81.4	80.1	77.0	0.76	2.60	6.3	3.0	3.0	3.8	0.0028	18.5
IE2-WE1R 90 LW4	1.5	9.95	1440	IE2-	82.8	83.8	81.4	0.76	3.40	6.5	2.7	2.7	3.6	0.004	23
IE2-WE1R 100 S4	2.2	14.5	1445	IE2-	84.3	84.9	82.7	0.79	4.67	7.3	2.7	2.5	3.1	0.00725	30
IE2-WE1R 100 LW4	3.0	19.8	1445	IE2-	85.5	85.8	83.6	0.79	6.33	7.8	3.0	2.9	3.6	0.009	36
IE2-WE1R 112 MZ4	4.0	26.4	1445	IE2-	86.6	86.8	84.9	0.80	8.30	8.2	2.8	2.6	3.6	0.013	50
IE2-WE2R 132 SY4	5.5	36.2	1450	IE2-	87.7	87.7	86.4	0.84	10.80	8.0	2.5	2.3	3.8	0.015	58
IE2-WE1R 132 S4	5.5	35.7	1470	IE2-	89.8	89.9	88.4	0.87	10	7.4	2.3	1.9	3.4	0.035	87
IE2-WE1R 132 M4	7.5	48.7	1470	IE2-	89.9	90.0	88.5	0.82	14.5	8.5	2.6	2.1	4.0	0.035	88
IE2-WE1R 160 M4	11.0	71	1475	IE2-	90.6	90.3	88.5	0.82	21.5	8.1	3.1	2.4	3.4	0.078	122
IE2-WE2R 160 M4	11	71.5	1470	IE2-	90.3	90.3	88.5	0.78	22.5	7.8	2.4	2.1	3.9	0.043	105
IE2-WE1R 160 L4	15.0	97	1470	IE2-	90.6	90.9	90.5	0.87	27.5	8.3	2.7	2.2	3.2	0.115	160
IE2-WE2R 160 L4	15	97	1480	IE2-	92.0	92.0	90.6	0.84	28	9.1	3.0	2.5	3.9	0.115	161
IE2-WE1R 180 M4	18.5	120	1475	IE2-	91.5	91.5	90.4	0.86	34	6.8	1.8	1.5	2.7	0.168	207
IE2-WE2R 180 M4	18.5	120	1470	IE2-	91.2	90.6	89.3	0.78	37.5	6.4	2.0	1.6	2.8	0.138	176
IE2-WE1R 180 L4	22	142	1475	IE2-	91.6	91.4	89.9	0.83	42	7.3	2.1	1.7	3.0	0.168	215
IE2-WE1R 200 L4	30	194	1480	IE2-	92.3	91.3	88.2	0.80	58.5	7.3	2.1	1.7	2.9	0.275	277
IE2-WE1R 225 S4	37	240	1475	IE2-	92.7	91.8	90.7	0.84	68.5	7.4	2.2	1.7	2.7	0.313	313
IE2-WE1R 225 M4	45	290	1483	IE2-	93.1	93.0	91.1	0.84	83	7.9	2.3	1.9	2.4	0.525	390
IE2-WE2R 225 M4	45	291	1475	IE2-	93.1	92.9	92.1	0.80	87	7.6	2.6	1.9	3.1	0.356	346
IE2-WE1R 250 M4	55	354	1485	IE2-	94.0	94.1	92.5	0.84	101	8.0	2.0	1.7	2.3	0.95	535
IE2-WE2R 250 M4	55	356	1477	IE2-	93.9	93.8	93.7	0.82	103	7.5	2.4	1.9	2.4	0.62	435
IE2-WE1R 280 S4	75	482	1485	IE2-	94.2	94.4	92.1	0.84	137	7.2	1.8	1.6	2.1	0.95	550
IE2-WE1R 280 M4	90	580	1483	IE2-	94.3	94.5	94.0	0.84	164	7.6	1.8	1.6	2.3	1.10	610
IE2-WE1R 315 S4	110	707	1485	IE2-	94.8	94.8	94.0	0.82	204	8.5	1.8	1.5	2.7	1.96	760
IE2-WE1R 315 M4	132	849	1484	IE2-	95.0	95.0	94.5	0.83	242	8.2	1.8	1.6	2.3	2.27	850
IE2-WE1R 315 MX4	160	1031	1482	IE2-	95.0	95.0	94.5	0.84	289	7.4	1.6	1.4	2.2	2.73	975
IE2-WE1R 315 MY4	200	1282	1490	IE2-	95.1	95.1	94.5	0.87	349	8.5	1.8	1.6	2.5	4.82	1270
IE2-WE1R 315 L4	250	1602	1490	IE2-	95.4	95.4	95.3	0.88	430	9.0	2.2	1.5	2.7	5.93	1450
IE2-WE1R 315 LX4	315	2019	1490	IE2-	95.4	95.4	95.0	0.88	542	9.0	2.4	1.6	2.6	6.82	1630
IE2-WE2R 355 M4	355	2271	1493	IE2-	95.5	95.5	95.0	0.87	617	8.0	1.3	1.0	2.7	7.90	2150
IE2-WE2R 355 MX4	400	2557	1494	IE2-	95.5	95.5	95.5	0.88	687	8.5	1.3	1.0	3.0	9.50	2400
IE2-WE2R 355 LY4	450	2873	1496	IE2-	95.5	95.5	95.5	0.86	791	8.5	1.4	0.8	2.9	10.00	2500
IE2-WE2R 355 L4	500	3198	1493	IE2-	95.5	95.5	95.5	0.84	900	8.0	1.2	0.9	3.0	10.00	2500

Three-phase motors with squirrel-cage rotor, High Efficiency IE2

with surface cooling, duty type S1, continuous duty
for rated voltage, thermal class 155 (F), degree of protection IP 55, 50 Hz



Motor selection data													Design point 400 V, 50 Hz		
Type	P _B kW	M _B Nm	n _B rpm	η _B IEC/EN 60034-2-1			cosφ _B -	I _B A	I _A /I _B -	M _A /M _B -	M _G /M _B -	M _K /M _B -	J kgm ²	m kg	
				100 %	75 %	50 %									
Synchronous speed 1000 rpm – 6-pole version															
IE2-WE2R 63 G6	0.12	1.3	880	IE2-	50.6	47.0	39.5	0.59	0.59	2.6	2.1	2.1	2.3	0.00027	5.7
IE2-WE2R 71 K6	0.18	1.9	920	IE2-	56.6	54.4	48.5	0.52	0.8	2.9	2.0	2.0	2.3	0.0006	8.3
IE2-WE2R 71 G6	0.25	2.6	915	IE2-	61.6	57.5	51.6	0.55	1.1	2.9	2.0	2.0	2.2	0.0006	8.3
IE2-WE2R 80 K6	0.37	3.8	935	IE2-	67.6	68.5	63.3	0.65	1.17	3.7	2.1	2.1	2.6	0.00175	12.5
IE2-WE1R 80 GY6	0.55	5.6	945	IE2-	73.1	72.6	68.4	0.67	1.6	3.8	1.9	1.9	2.4	0.00325	15.0
IE2-WE2R 90 S6	0.75	7.6	945	IE2-	75.9	75.5	72.1	0.67	2.12	4.0	1.8	1.8	2.4	0.00425	19.0
IE2-WE1R 90 LW6	1.1	11.0	955	IE2-	78.1	78.0	75.1	0.69	2.95	4.7	2.5	2.4	2.8	0.00625	24.0
IE2-WE2R 100 L6	1.5	15.1	950	IE2-	79.8	80.4	77.6	0.7	3.85	5.1	2.5	2.4	3.0	0.0072	30.0
IE2-WE1R 112 MX6	2.2	21.9	960	IE2-	81.8	81.9	77.5	0.65	5.9	6.4	3.0	2.9	3.7	0.0139	37.0
IE2-WE1R 132 S6	3.0	29.8	963	IE2-	84.9	85.2	83.9	0.80	6.4	6.0	2.0	1.3	3.0	0.023	55
IE2-WE2R 132 M6	4.0	40	955	IE2-	85.1	86.0	85.2	0.82	8.3	5.7	2.1	2.0	2.9	0.029	66
IE2-WE1R 132 M6	4.0	39.6	965	IE2-	85.5	85.5	83.8	0.79	8.5	5.1	1.8	1.6	2.4	0.043	76
IE2-WE1R 132 MX6	5.5	54	970	IE2-	86.1	85.5	82.4	0.77	12	5.7	2.2	1.7	2.7	0.053	85
IE2-WE1R 160 M6	7.5	73	975	IE2-	87.4	88.1	86.0	0.81	15.5	6.3	2.5	2.1	2.9	0.113	118
IE2-WE2R 160 M6	7.5	74	970	IE2-	87.5	87.6	85.9	0.79	15.5	5.9	2.1	1.8	2.9	0.053	103
IE2-WE1R 160 L6	11.0	108	970	IE2-	88.7	87.9	86.3	0.85	21	5.8	2.2	1.9	2.7	0.145	135
IE2-WE2R 160 L6	11.0	108	975	IE2-	88.9	88.8	87.0	0.81	22	6.8	2.7	2.4	3.1	0.166	155
IE2-WE1R 180 L6	15.0	147	975	IE2-	89.7	88.8	86.7	0.84	28.5	6.2	2.1	1.8	2.8	0.228	185
IE2-WE2R 180 L6	15	148	970	IE2-	89.7	88.8	87.8	0.83	29	5.6	2.3	1.7	2.6	0.166	157
IE2-WE1R 200 L6	18.5	180	980	IE2-	90.4	88.8	86.5	0.85	35	6.6	2.3	1.7	2.9	0.268	208
IE2-WE1R 200 LX6	22	214	980	IE2-	90.9	90.2	88.5	0.86	40.5	6.4	2.2	1.8	2.7	0.443	272
IE2-WE2R 200 LX6	22	215	975	IE2-	90.9	89.9	88.5	0.84	41.5	6.7	2.4	2.0	3.0	0.324	238
IE2-WE1R 225 M6	30	291	985	IE2-	92.0	91.5	90.0	0.86	54.5	7.3	2.5	2.2	2.9	0.825	365
IE2-WE2R 225 M6	30	294	975	IE2-	91.7	91.4	90.6	0.87	54.5	6.7	2.3	1.9	2.8	0.514	308
IE2-WE1R 250 M6	37	359	985	IE2-	92.2	91.7	90.7	0.85	68	6.4	2.7	1.8	2.4	1.28	480
IE2-WE2R 250 M6	37	361	979	IE2-	92.2	92.3	91.8	0.86	67.5	6.6	2.7	2.0	2.6	0.92	407
IE2-WE1R 280 S6	45	437	983	IE2-	93.0	92.7	92.4	0.87	80.5	6.5	2.2	1.7	2.4	1.48	560
IE2-WE1R 280 M6	55	531	990	IE2-	93.5	93.5	93.0	0.85	100	7.6	2.0	1.5	2.5	2.63	710
IE2-WE1R 315 S6	75	723	990	IE2-	93.9	93.7	93.5	0.87	133	7.8	1.9	1.5	2.5	3.33	804
IE2-WE1R 315 M6	90	868	990	IE2-	94.0	94.0	93.5	0.88	157	7.5	1.8	1.5	2.5	3.60	865
IE2-WE1R 315 MX6	110	1061	990	IE2-	94.3	94.3	94.0	0.87	194	7.5	1.8	1.4	2.3	6.67	1210
IE2-WE1R 315 MY6	132	1273	990	IE2-	94.6	94.3	94.0	0.87	231	7.5	1.9	1.4	2.2	6.67	1250
IE2-WE1R 315 L6	160	1543	990	IE2-	94.8	94.5	93.5	0.88	277	7.5	2.0	1.5	2.4	8.60	1430
IE2-WE1R 315 LX6	200	1929	990	IE2-	95.0	95.0	94.5	0.86	353	7.0	1.9	1.5	2.2	8.60	1460
IE2-WE2R 355 M6	250	2402	994	IE2-	95.0	95.0	94.7	0.84	452	7.0	1.5	1.2	2.2	8.20	1850
IE2-WE2R 355 MX6	315	3023	995	IE2-	95.2	95.2	95.2	0.86	555	7.0	1.3	1.1	2.2	12.1	2200
IE2-WE2R 355 LY6	355	3407	995	IE2-	95.0	95.0	94.0	0.77	700	7.5	1.8	1.5	2.6	14.0	2400

Three-phase motors with squirrel-cage rotor, High Efficiency IE2

with surface cooling, duty type S1, continuous duty
for rated voltage, thermal class 155 (F), degree of protection IP 55, 50 Hz

Motor selection data												Design point 400 V, 50 Hz			
Type	P _B kW	M _B Nm	n _B rpm	η _B IEC/EN 60034-2-1			cosφ _B -	I _B 400 V A	I _A /I _B -	M _A /M _B -	M _S /M _B -	M _K /M _B -	J kgm ²	m kg	
				100 %	75 %	50 %									
				Synchronous speed 750 rpm – 8-pole version											
IE2-WE2R 71 G8	0.12	1.7	670	IE2-	39.8	39.8	31.9	0.54	0.73	2.10	1.80	1.80	2.00	0.0006	8
IE2-WE2R 80 K8	0.18	2.5	690	IE2-	45.9	52.2	44.0	0.59	0.78	2.70	1.90	1.90	2.20	0.0013	11
IE2-WE2R 80 G8	0.25	3.4	695	IE2-	50.6	50.4	42.5	0.56	1.12	3.00	2.30	2.30	2.50	0.00175	12
IE2-WE2R 90 S8	0.37	5.1	700	IE2-	56.1	57.3	50.7	0.54	1.60	3.00	1.50	1.50	2.00	0.003	15
IE2-WE2R 90 L8	0.55	7.6	695	IE2-	61.7	61.3	54.9	0.60	2.04	3.30	1.50	1.50	2.00	0.00375	18
IE2-WE2R 100 L8	0.75	10.2	705	IE2-	66.2	64.5	58.7	0.60	2.90	3.10	1.50	1.50	2.00	0.00625	23
IE2-WE1R 100 LY8	1.1	14.9	705	IE2-	70.8	71.2	67.6	0.67	3.25	4.00	2.00	2.00	2.40	0.009	28
IE2-WE1R 112 M8	1.5	20.3	705	IE2-	74.1	73.6	70.1	0.62	4.50	4.20	2.00	2.00	2.70	0.0139	37
IE2-WE1R 132 S8	2.2	29.2	720	IE2-	81.7	81.0	77.5	0.65	6	4.8	2.2	2.0	3.2	0.0180	55
IE2-WE2R 132 M8	3.0	39.8	710	IE2-	80.0	80.8	79.0	0.73	7.4	4.9	1.9	1.9	2.7	0.0290	65
IE2-WE1R 132 M8	3.0	39.8	720	IE2-	82.7	83.0	81.3	0.74	7.1	3.9	1.6	1.3	1.9	0.0430	74
IE2-WE1R 160 M8	4.0	53.2	718	IE2-	84.2	83.7	81.9	0.72	9.5	4.6	1.6	***)	2.5	0.0530	86
IE2-WE1R 160 MX8	5.5	72.0	730	IE2-	86.9	86.6	84.1	0.72	12.5	4.8	2.1	1.8	2.6	0.1130	115
IE2-WE2R 160 MX8	5.5	73	715	IE2-	83.9	84.0	81.9	0.71	13.5	4.3	1.7	1.5	2.5	0.0530	103
IE2-WE1R 160 L8	7.5	99	725	IE2-	87.5	87.0	83.5	0.77	16	5.5	2.0	***)	2.8	0.1450	136
IE2-WE1R 180 L8	11.0	144	727	IE2-	88.2	88.2	86.7	0.78	23	4.9	1.8	1.6	2.4	0.2280	175
IE2-WE2R 180 L8	11	144	730	IE2-	87.9	87.4	85.2	0.67	25.5	4.3	1.9	1.6	2.3	0.1660	157
IE2-WE1R 200 L8	15.0	197	727	IE2-	88.2	88.1	86.4	0.77	32	4.9	1.9	1.7	2.3	0.2680	200
IE2-WE1R 225 S8	18.5	242	730	IE2-	89.6	89.4	87.2	0.78	38	5.4	2.1	2.0	2.8	0.440	265
IE2-WE2R 225 S8	18.5	240	735	IE2-	90.7	90.7	89.4	0.8	37	6.1	2.1	1.9	2.9	0.514	305
IE2-WE1R 225 M8	22	287	733	IE2-	90.6	89.4	89.9	0.78	45	5.6	2.2	1.8	2.6	0.825	380
IE2-WE2R 225 M8	22	286	735	IE2-	90.3	90.3	88.7	0.77	45.5	6.1	2.2	2.0	2.9	0.514	307
IE2-WE1R 250 M8	30	389	737	IE2-	92.1	92.4	91.6	0.79	59.5	5.0	2.0	1.6	2.1	1.350	480
IE2-WE2R 250 M8	30	391	732	IE2-	91.5	91.7	90.9	0.77	61.5	5.6	2.3	2.0	2.5	0.950	405
IE2-WE1R 280 S8	37	479	737	IE2-	92.2	92.1	90.9	0.79	73.5	6.0	2.3	1.9	2.5	1.55	550
IE2-WE1R 280 M8	45	581	740	IE2-	92.7	92.7	92.0	0.79	88.5	6.7	1.8	1.5	2.5	2.63	690
IE2-WE1R 315 S8	55	710	740	IE2-	92.2	92.2	92.1	0.80	108	6.3	1.8	1.5	2.3	2.63	690
IE2-WE1R 315 M8	75	968	740	IE2-	93.5	93.5	93.0	0.81	143	6.0	1.8	1.5	2.1	3.6	880
IE2-WE1R 315 MX8	90	1161	740	IE2-	92.1	91.6	90.1	0.81	174	6.0	1.9	***)	2.2	6	1050
IE2-WE1R 315 MY8	110	1420	740	IE2-	93.8	93.3	91.2	0.81	209	6.5	2.1	***)	2.4	6.76	1250
IE2-WE1R 315 L8	132	1704	740	IE2-	94.4	94.0	93.5	0.83	243	7.5	2.2	1.8	2.5	8.71	1430
IE2-WE1R 315 LX8	160	2065	740	IE2-	94.2	94.2	93.8	0.80	306	7.2	2.2	1.8	2.5	8.71	1430
IE2-WE2R 355 M8	200	2571	743	IE2-	94.7	94.1	91.5	0.77	396	***)	***)	***)	***)	9.5	1850
IE2-WE2R 355 MX8	250	3205	745	IE2-	95.8	95.8	95.5	0.83	454	7.0	1.2	1.0	2.6	13.4	2200
IE2-WE2R 355 LY8	280	3599	743	IE2-	94.8	94.1	91.5	0.78	547	***)	***)	***)	***)	15.8	2400

***) upon request

Three-phase motors with squirrel-cage rotor, High Efficiency IE2

with surface cooling, duty type S1, continuous duty
for rated voltage, thermal class 155 (F), degree of protection IP 55, 50/60 Hz



Motor selection data															Design point 400 V, 50 Hz 460 V, 60 Hz		
Type	U _B V	f _B Hz	P _B kW	M _B Nm	n _B rpm	η _B IEC/EN 60034-2-1			cosφ _B -	I _B A	I _A /I _B -	M _A /M _B -	M _S /M _B -	M _K /M _B -	J kgm ²	m kg	
						100 %	75 %	50 %									
Synchronous speed 3000 rpm/3600 rpm – 2-pole version																	
IE2-WE2R 56 G2	400	50	0.12	0.4	2830	IE2-	53.6	69.6	60.8	0.77	0.32	4.5	2.1	2.1	2.3	0.00013	4.5
	460	60	0.14	0.39	3425	IE2-	59.5	74.1	74.3	0.77	0.32	5.0	2.1	2.1	2.6		
IE2-WE2R 63 K2	400	50	0.18	0.62	2790	IE2-	60.4	63.1	57.6	0.76	0.51	4.1	1.9	1.9	2.2	0.00013	4.9
	460	60	0.21	0.59	3400	IE2-	64.0	67.6	61.1	0.75	0.51	4.7	2.4	2.4	2.7		
IE2-WE2R 63 G2	400	50	0.25	0.86	2775	IE2-	64.8	66.7	61.9	0.8	0.67	4.2	1.9	1.9	2.2	0.00015	5.2
	460	60	0.30	0.85	3390	IE2-	68.0	70.6	65.7	0.80	0.66	4.5	2.0	1.9	2.1		
IE2-WE2R 71 K2	400	50	0.37	1.28	2750	IE2-	69.5	70.8	69.4	0.84	0.89	4.6	1.8	1.8	2.1	0.00025	6.7
	460	60	0.44	1.25	3350	IE2-	72.0	73.7	70.0	0.85	0.88	4.9	1.9	1.9	2.2		
IE2-WE2R 71 G2	400	50	0.55	1.89	2775	IE2-	74.1	75.0	72.0	0.81	1.32	5.1	2.3	2.1	2.6	0.00032	7.6
	460	60	0.65	1.84	3370	IE2-	75.5	76.1	72.6	0.83	1.30	5.6	2.1	2.1	2.6		
IE2-WE2R 80 K2	400	50	0.75	2.54	2825	IE2-	77.4	77.1	72.9	0.81	1.72	5.9	2.4	2.4	2.4	0.00057	10.7
	460	60	0.9	2.52	3415	IE2-	75.5	76.5	71.9	0.82	1.76	5.7	2.6	2.3	2.5		
IE2-WE1R 80 G2	400	50	1.1	3.64	2885	IE2-	79.6	82.1	81.2	0.89	2.15	7.8	2.5	2.3	2.8	0.0017	18
	460	60	1.30	3.58	3470	IE2-	84.0	84.6	81.4	0.89	2.15	8.0	2.4	2.2	2.7		
IE2-WE2R 90 S2	400	50	1.5	4.99	2870	IE2-	81.3	82.0	79.4	0.8	3.3	6.6	3.2	3.2	3.7	0.00132	16
	460	60	1.80	4.98	3455	IE2-	84.0	84.2	82.3	0.82	3.25	7.2	3.0	2.9	3.6		
IE2-WE2R 90 L2	400	50	2.2	7.37	2850	IE2-	83.2	81.5	***)	0.85	4.55	7.5	2.8	2.3	2.9	0.0017	19
	460	60	2.6	7.22	3440	IE2-	85.5	85.8	84.7	0.85	4.50	7.8	2.7	2.7	2.9		
IE2-WE2R 100 LY2	400	50	3	9.97	2875	IE2-	84.6	85.1	83.6	0.85	6	7.4	2.6	2.3	3.3	0.0045	28.5
	460	60	3.00	8.20	3495	IE2-	87.5	86.9	84.7	0.83	5.20	8.4	2.6	2.2	3.8		
IE2-WE1R 112 M2	400	50	4	13.2	2900	IE2-	85.8	86.3	***)	0.81	8.4	7.0	2.2	2.1	2.9	0.0045	32
	460	60	4.00	10.88	3510	IE2-	87.5	87.4	84.8	0.80	7.30	8.0	2.1	2.1	3.1		
IE2-WE1R 132 SY2T	400	50	5.5	18.20	2890	IE2-	87.0	86.2	86.4	0.84	11	7.2	2.1	1.7	2.8	0.0055	40.0
	460	60	5.5	15.01	3500	IE2-	88.5	87.8	85.6	0.84	9.5	8.8	2.4	2.2	3		
IE2-WE1R 132 SX2T	400	50	7.5	24.9	2880	IE2-	88.1	88.0	***)	0.84	14.8	6.3	1.5	1.2	2.6	0.0068	48
	460	60	9.00	24.66	3485	IE2-	89.5	88.7	87.5	0.83	15.40	6.7	1.8	1.7	2.9		
IE2-WE1R 132 SX2	400	50	7.5	24.5	2925	IE2-	88.8	89.2	88.3	0.91	13.5	6.7	2.1	1.6	2.9	0.0168	75
	460	60	9.0	24.5	3505	IE2-	89.5	89.4	88.5	0.90	14.0	6.2	2.1	1.7	2.8		

***) upon request

Three-phase motors with squirrel-cage rotor, High Efficiency IE2

with surface cooling, duty type S1, continuous duty
for rated voltage, thermal class 155 (F), degree of protection IP 55, 50/60 Hz

IE2 | EU REGULATION 640/2009
USE WITH VARIABLE
SPEED DRIVE ONLY!

Motor selection data															Design point 400 V, 50 Hz 460 V, 60 Hz		
Type	U _B V	f _B Hz	P _B kW	M _B Nm	n _B rpm	η _B IEC/EN 60034-2-1			cosφ _B -	I _B A	I _x /I _B -	M _x /M _B -	M _y /M _B -	M _z /M _B -	J kgm ²	m kg	
						100 %	75 %	50 %									
Synchronous speed 3000 rpm/3600 rpm – 2-pole version																	
IE2-WE1R 160 M2	400	50	11.0	35.6	2950	IE2-	90.3	90.3	89.1	0.90	19.5	7.7	2.3	1.7	3.1	0.0258	125
	460	60	13.0	35.0	3550	IE2-	91.0	90.9	89.5	0.91	20.0	7.3	2.0	1.6	2.7		
IE2-WE1R 160 MX2	400	50	15.0	48.7	2940	IE2-	90.7	90.5	89.1	0.92	26	6.7	1.8	1.4	2.6	0.0675	140
	460	60	16.5	44.6	3535	IE2-	90.2	89.7	88.4	0.91	25.0	6.5	1.9	1.4	2.6		
IE2-WE1R 160 L2	400	50	18.5	60.2	2935	IE2-	91.0	91.4	91.4	0.91	32	7.2	2.0	1.5	2.8	0.0675	140
	460	60	22.0	59.6	3525	IE2-	91.6	91.3	89.6	0.92	37.5	7.0	1.8	1.3	2.6		
IE2-WE1R 180 M2	400	50	22	72	2935	IE2-	91.3	90.6	86.4	0.90	38.5	6.2	1.4	1.1	2.4	0.105	173
	460	60	26	70	3545	IE2-	91.7	91.6	90.9	0.90	39.5	6.0	1.5	1.2	2.4		
IE2-WE1R 200 L2	400	50	30	97	2945	IE2-	92.0	91.3	90.5	0.91	52	6.9	1.7	1.3	2.6	0.128	210
	460	60	36	97	3550	IE2-	92.4	92.5	91.6	0.91	54.0	6.0	1.4	1.1	2.3		
IE2-WE1R 200 LX2	400	50	37	120	2940	IE2-	92.5	92.3	91.6	0.92	63	7.4	1.9	1.4	2.9	0.154	233
	460	60	44	119	3545	IE2-	93.0	92.4	92.1	0.91	65.5	6.8	1.9	1.5	2.8		
IE2-WE2R 200 LX2	400	50	37	120	2940	IE2-	92.5	92.3	91.6	0.92	63	7.4	1.9	1.4	2.9	0.154	233
	460	60	44	119	3545	IE2-	93.0	92.4	92.1	0.91	65.5	6.8	1.9	1.5	2.8		
IE2-WE1R 225 M2	400	50	45	146	2950	IE2-	92.9	92.2	91.2	0.87	80.5	6.9	1.7	1.1	2.7	0.220	295
	460	60	54	145	3545	IE2-	93.0	92.5	91.8	0.88	83.0	6.9	1.7	1.4	2.8		
IE2-WE1R 250 M2	400	50	55	178	2955	IE2-	93.5	93.7	93.2	0.89	95.5	8.2	2.3	1.9	2.8	0.375	385
	460	60	66	178	3550	IE2-	93.6	93.7	93.0	0.90	98.5	7.6	2.1	1.8	2.7		
IE2-WE1R 280 S2	400	50	75	241	2970	IE2-	94.1	94.0	91.5	0.90	128	7.9	2.1	1.7	3.0	0.65	500
	460	60	90	241	3570	IE2-	94.5	93.9	92.8	0.91	131	7.3	1.9	1.6	2.8		
IE2-WE1R 280 M2	400	50	90	289	2970	IE2-	94.4	94.1	91.9	0.91	151	7.7	2.0	1.7	2.8	0.68	550
	460	60	110	294	3568	IE2-	94.5	94.0	93.7	0.91	161	7.5	1.9	1.6	2.7		
IE2-WE1R 315 S2	400	50	110	353	2975	IE2-	94.5	94.3	93.3	0.89	189	8.0	1.3	1.2	2.4	1.21	730
	460	60	120	320	3580	IE2-	94.5	94.0	93.0	0.89	179	8.5	1.4	1.3	2.5		
IE2-WE1R 315 M2	400	50	132	424	2975	IE2-	95.0	94.8	94.5	0.89	225	9.2	1.4	1.2	2.4	1.44	820
	460	60	145	387	3580	IE2-	95.0	94.5	94.0	0.90	213	9.4	1.4	1.2	2.4		
IE2-WE1R 315 MX2	400	50	160	514	2973	IE2-	94.8	94.8	94.8	0.89	274	8.2	1.3	1.3	2.4	1.76	955
	460	60	175	467	3575	IE2-	95.4	95.0	94.0	0.90	256	8.2	1.7	1.6	2.7		
IE2-WE1R 315 MY2	400	50	200	640	2983	IE2-	95.4	95.0	94.3	0.88	344	9.4	2.8	2.0	3.0	2.82	1200
	460	60	220	586	3585	IE2-	95.4	95.0	94.0	0.89	325	9.5	2.8	2.0	3.0		
IE2-WE1R 315 L2	400	50	250	800	2984	IE2-	95.4	95.4	95.4	0.92	411	9.0	2.3	1.2	2.3	3.66	1450
	460	60	280	747	3580	IE2-	95.5	95.5	95.5	0.92	400	8.0	2.3	1.4	2.3		
IE2-WE1R 315 LX2	400	50	315	1008	2985	IE2-	95.4	95.4	95.0	0.92	518	8.5	2.8	1.6	2.5	4.43	1700
	460	60	330	879	3585	IE2-	95.4	95.4	95.4	0.92	472	9.0	2.8	1.6	2.5		
IE2-WE2R 355 M2	400	50	355	1136	2985	IE2-	95.5	95.5	95.5	0.92	583	7.7	1.3	1.0	2.6	4.20	2000
	460	60	375	999	3585	IE2-	95.4	95.0	94.5	0.91	542	8.5	1.5	1.3	2.2		
IE2-WE2R 355 MX2	400	50	400	1278	2990	IE2-	95.5	95.5	95.5	0.91	664	9.4	1.8	1.0	3.0	4.50	2200
	460	60	440	1170	3590	IE2-	95.8	95.5	95.0	0.91	633	9.4	1.7	1.1	3.0		
IE2-WE2R 355 LY2	400	50	450	1440	2985	IE2-	95.5	95.5	95.5	0.92	739	7.0	1.3	0.9	2.4	7.10	2400
	460	60	490	1303	3590	IE2-	95.5	95.5	95.0	0.92	700	7.5	1.5	0.9	2.4		
IE2-WE2R 355 L2	400	50	500	1597	2990	IE2-	95.5	95.5	95.5	0.92	821	8.5	1.5	1.2	2.5	7.10	2400
	460	60	550	1467	3580	IE2-	95.5	95.5	95.0	0.92	786	8.5	1.5	1.0	2.4		

Three-phase motors with squirrel-cage rotor, High Efficiency IE2

with surface cooling, duty type S1, continuous duty
for rated voltage, thermal class 155 (F), degree of protection IP 55, 50/60 Hz



Motor selection data															Design point 400 V, 50 Hz 460 V, 60 Hz		
Type	U _B V	f _B Hz	P _B kW	M _B Nm	n _B rpm	IEC/EN 60034-2-1	η _B			cosφ _B -	I _B A	I _N /I _B -	M _N /M _B -	M _S /M _B -	M _R /M _B -	J kgm ²	m kg
							100 %	75 %	50 %								
Synchronous speed 1500 rpm/1800 rpm – 4-pole version																	
IE2-W21R 63 K4	400	50	0.12	0.82	1400	IE2-	59.1	69.1	63.9	0.71	0.35	3.8	2.0	1.9	2.3	0.0004	6.3
	460	60	0.14	0.79	1700	IE2-	64.0	70.3	65.8	0.71	0.35	4.1	2.0	1.9	2.4		
IE2-WE1R 63 GY4	400	50	0.18	1.23	1395	IE2-	64.7	66.3	61.3	0.72	0.54	3.5	1.7	1.7	2.2	0.0004	6.3
	460	60	0.21	1.18	1695	IE2-	68.0	69.3	64.7	0.71	0.53	3.0	1.9	1.9	2.4		
IE2-WE2R 71 K4	400	50	0.25	1.71	1395	IE2-	68.5	68.1	63.8	0.70	0.73	3.9	2.1	2.1	2.5	0.0005	7.8
	460	60	0.30	1.7	1690	IE2-	70.0	73.2	69.4	0.71	0.72	4.1	2.1	2.1	2.5		
IE2-WE1R 71 GY4	400	50	0.37	2.48	1425	IE2-	72.7	72.2	68.6	0.69	1.00	4.9	2.4	2.4	3.0	0.00087	9.9
	460	60	0.44	2.44	1720	IE2-	72.0	78.2	74.6	0.71	0.98	5.2	2.1	2.1	2.9		
IE2-WE2R 80 K4	400	50	0.55	3.71	1415	IE2-	77.1	77.1	73.9	0.72	1.42	4.9	2.6	2.5	2.8	0.00107	11.7
	460	60	0.65	3.67	1715	IE2-	78.0	80.1	77.6	0.75	1.35	5.3	2.5	2.3	2.9		
IE2-WE1R 80 GY4	400	50	0.75	5.01	1430	IE2-	79.6	78.0	74.7	0.80	1.73	5.7	2.2	2.2	3.1	0.00207	14.5
	460	60	0.90	4.98	1725	IE2-	78.0	79.4	76.5	0.81	1.75	6.1	2.2	2.1	3.2		
IE2-WE2R 90 S4	400	50	1.10	7.32	1435	IE2-	81.4	80.1	77.0	0.76	2.60	6.3	3.0	3.0	3.8	0.0028	18.5
	460	60	1.30	7.18	1730	IE2-	84.0	83.6	80.6	0.8	2.5	7.0	3.0	2.8	3.8		
IE2-WE1R 90 LW4	400	50	1.50	9.95	1440	IE2-	82.8	83.8	81.4	0.76	3.40	6.5	2.7	2.7	3.6	0.004	23
	460	60	1.80	9.91	1735	IE2-	84.0	84.9	74.7	0.78	3.40	6.7	2.6	2.5	3.6		
IE2-WE1R 100 L4	400	50	2.20	14.4	1455	IE2-	84.3	85.2	81.7	0.77	4.80	9.3	3.2	3.0	3.6	0.009	36
	460	60	2.60	14.1	1755	IE2-	87.5	86.7	84.7	0.76	4.90	7.7	2.2	2.1	3.4		
IE2-WE1R 100 LW4	400	50	3.00	19.8	1445	IE2-	85.5	85.8	83.6	0.79	6.33	7.8	3.0	2.9	3.6	0.009	36
	460	60	3.60	19.7	1745	IE2-	87.5	88.1	86.5	0.79	6.50	7.6	2.7	2.5	3.8		
IE2-WE1R 112 MZ4	400	50	4.00	26.4	1445	IE2-	86.6	86.8	84.9	0.80	8.30	8.2	2.8	2.6	3.6	0.013	50
	460	60	4.50	24.6	1745	IE2-	87.5	87.5	85.9	0.80	8.05	7.8	2.4	2.3	3.5		
IE2-WE2R 132 SY4	400	50	5.50	36.2	1450	IE2-	87.7	87.7	86.4	0.84	10.80	8.0	2.5	2.3	3.8	0.015	***)
	460	60	6.60	36.12	1745	IE2-	89.5	89.3	88.6	0.87	10.80	7.7	2.1	1.9	3.6		
IE2-WE1R 132 S4	400	50	5.5	35.7	1470	IE2-	89.8	89.9	88.4	0.87	10	7.4	2.3	1.9	3.4	0.035	87
	460	60	6.6	35.7	1765	IE2-	89.8	90.0	88.5	0.88	11	6.6	2.2	1.6	3.0		
IE2-WE1R 132 M4	400	50	7.5	48.7	1470	IE2-	89.9	90.0	88.5	0.82	14.5	8.5	2.6	2.1	4.0	0.035	88
	460	60	9.0	48.6	1770	IE2-	90.8	90.6	89.0	0.83	15	8.1	2.5	2.0	3.8		

***) upon request

Three-phase motors with squirrel-cage rotor, High Efficiency IE2

with surface cooling, duty type S1, continuous duty
for rated voltage, thermal class 155 (F), degree of protection IP 55, 50/60 Hz

IE2

EU REGULATION 640/2009
 USE WITH VARIABLE
 SPEED DRIVE ONLY!

Motor selection data																Design point 400 V, 50 Hz 460 V, 60 Hz	
Type	U _B	f _B	P _B	M _B	n _B	η _B			cosφ _B	I _B	I _A /I _B	M _A /M _B	M _S /M _B	M _K /M _B	J	m	
	V	Hz	kW	Nm	rpm	IEC/EN 60034-2-1			-	A	-	-	-	-	kgm ²	kg	
						100 %	75 %	50 %									
Synchronous speed 1500 rpm/1800 rpm – 4-pole version																	
IE2-WE1R 160 M4	400	50	11.0	71	1475	IE2-	90.6	90.3	88.5	0.82	21.5	8.1	3.1	2.4	3.4	0.078	122
	460	60	13.0	70	1775	IE2-	91.1	90.8	89.2	0.82	22.0	7.7	2.8	2.2	3.2		
IE2-WE2R 160 M4	400	50	11	71.5	1470	IE2-	90.3	90.3	88.5	0.78	22.5	7.8	2.4	2.1	3.9	0.043	105
	460	60	13	70	1765	IE2-	91.3	91.5	90.4	0.80	22.5	7.5	2.3	1.9	3.6		
IE2-WE1R 160 L4	400	50	15.0	97	1470	IE2-	90.6	90.9	90.5	0.87	27.5	8.3	2.7	2.2	3.2	0.115	160
	460	60	18.0	97	1770	IE2-	92.5	92.4	91.4	0.86	28.0	8.0	2.5	2.0	3.0		
IE2-WE2R 160 L4	400	50	15	97	1480	IE2-	92.0	92.0	90.6	0.84	28	9.1	3.0	2.5	3.9	0.115	161
	460	60	18	97	1775	IE2-	92.5	92.4	91.4	0.85	28.5	8.5	2.7	2.3	3.5		
IE2-WE1R 180 M4	400	50	18.5	120	1475	IE2-	91.5	91.5	90.4	0.86	34	6.8	1.8	1.5	2.7	0.168	207
	460	60	22.0	118	1775	IE2-	92.4	91.4	89.9	0.86	35.0	6.3	1.6	1.4	2.5		
IE2-WE2R 180 M4	400	50	18.5	120	1470	IE2-	91.2	90.6	89.3	0.78	37.5	6.4	2.0	1.6	2.8	0.138	176
	460	60	22	118	1775	IE2-	92.4	91.5	90.1	0.80	37.5	6.1	1.9	1.5	2.6		
IE2-WE1R 180 L4	400	50	22	142	1475	IE2-	91.6	91.4	89.9	0.83	42	7.3	2.1	1.7	3.0	0.168	215
	460	60	26	139	1780	IE2-	93.0	91.7	90.0	0.84	42.0	7.2	2.0	1.7	2.9		
IE2-WE1R 200 L4	400	50	30	194	1480	IE2-	92.3	91.3	88.2	0.80	58.5	7.3	2.1	1.7	2.9	0.275	277
	460	60	36	193	1780	IE2-	93.0	92.5	91.4	0.82	59.5	6.8	2.0	1.7	2.8		
IE2-WE1R 225 S4	400	50	37	240	1475	IE2-	92.7	91.8	90.7	0.84	68.5	7.4	2.2	1.7	2.7	0.313	313
	460	60	44	237	1775	IE2-	93.6	92.9	92.1	0.83	71.5	6.5	1.9	1.6	2.5		
IE2-WE1R 225 M4	400	50	45	290	1483	IE2-	93.1	93.0	91.1	0.84	83	7.9	2.3	1.9	2.4	0.525	390
	460	60	49	263	1780	IE2-	93.6	93.0	91.5	0.84	78.0	8.0	2.2	1.8	2.4		
IE2-WE2R 225 M4	400	50	45	291	1475	IE2-	93.1	92.9	92.1	0.80	87	7.6	2.6	1.9	3.1	0.356	346
	460	60	45	242	1775	IE2-	93.6	92.7	91.2	0.80	75.5	8.3	2.9	2.1	3.3		
IE2-WE1R 250 M4	400	50	55	354	1485	IE2-	94.0	94.1	92.5	0.84	101	8.0	2.0	1.7	2.3	0.95	535
	460	60	64	343	1780	IE2-	94.1	93.5	93.0	0.85	100	7.6	1.7	1.5	2.2		
IE2-WE2R 250 M4	400	50	55	356	1477	IE2-	93.9	93.8	93.7	0.82	103	7.5	2.4	1.9	2.4	0.62	435
	460	60	63	339	1777	IE2-	94.1	93.6	93.2	0.83	101	7.2	2.3	1.8	2.3		
IE2-WE1R 280 S4	400	50	75	482	1485	IE2-	94.2	94.4	92.1	0.84	137	7.2	1.8	1.6	2.1	0.95	550
	460	60	90	483	1779	IE2-	94.5	94.2	93.9	0.84	142	6.6	1.7	1.4	2.0		
IE2-WE1R 280 M4	400	50	90	580	1483	IE2-	94.3	94.5	94.0	0.84	164	7.6	1.8	1.6	2.3	1.10	610
	460	60	105	563	1780	IE2-	95.0	94.6	94.1	0.84	166	7.4	1.8	1.6	2.2		
IE2-WE1R 315 S4	400	50	110	707	1485	IE2-	94.8	94.8	94.0	0.82	204	8.5	1.8	1.5	2.7	1.96	760
	460	60	132	707	1784	IE2-	95.2	95.2	94.6	0.85	205	8.0	1.6	1.5	2.2		
IE2-WE1R 315 M4	400	50	132	849	1484	IE2-	95.0	95.0	94.5	0.83	242	8.2	1.8	1.6	2.3	2.27	850
	460	60	145	776	1784	IE2-	95.0	95.0	94.5	0.85	225	8.2	1.9	1.7	2.3		
IE2-WE1R 315 MX4	400	50	160	1031	1482	IE2-	95.0	95.0	94.5	0.84	289	7.4	1.6	1.4	2.2	2.73	975
	460	60	175	939	1780	IE2-	95.1	95.1	94.5	0.85	272	8.0	1.6	1.5	2.2		
IE2-WE1R 315 MY4	400	50	200	1282	1490	IE2-	95.1	95.1	94.5	0.87	349	8.5	1.8	1.6	2.5	4.82	1270
	460	60	220	1174	1790	IE2-	95.4	95.4	95.0	0.87	333	8.8	2.0	1.6	2.6		
IE2-WE1R 315 L4	400	50	250	1602	1490	IE2-	95.4	95.4	95.3	0.88	430	9.0	2.2	1.5	2.7	5.93	1450
	460	60	280	1792	1790	IE2-	95.4	95.4	95.3	0.88	419	8.5	2.2	1.6	2.5		
IE2-WE1R 315 LX4	400	50	315	2019	1490	IE2-	95.4	95.4	95.0	0.88	542	9.0	2.4	1.6	2.6	6.82	1630
	460	60	330	1761	1790	IE2-	95.4	94.5	93.5	0.87	499	9.2	2.5	1.7	1.7		
IE2-WE2R 355 M4	400	50	355	2271	1493	IE2-	95.5	95.5	95.0	0.87	617	8.0	1.3	1.0	2.7	7.90	2150
	460	60	375	1997	1793	IE2-	95.4	95.4	94.5	0.87	567	9.0	1.3	0.9	2.9		
IE2-WE2R 355 MX4	400	50	400	2557	1494	IE2-	95.5	95.5	95.5	0.88	687	8.5	1.3	1.0	3.0	9.50	2400
	460	60	425	2267	1790	IE2-	95.8	95.8	95.5	0.87	640	9.0	1.4	1.0	3.1		
IE2-WE2R 355 LY4	400	50	450	2873	1496	IE2-	95.5	95.5	95.5	0.86	791	8.5	1.4	0.8	2.9	10.00	2500
	460	60	475	2529	1794	IE2-	95.8	95.8	95.5	0.83	750	9.2	1.5	1.0	3.5		
IE2-WE2R 355 L4	400	50	500	3198	1493	IE2-	95.5	95.5	95.5	0.84	900	8.0	1.2	0.9	3.0	10.00	2500
	460	60	525	2795	1794	IE2-	95.8	95.8	95.5	0.83	829	9.0	1.3	1.0	3.3		

Three-phase motors with squirrel-cage rotor, High Efficiency IE2

with surface cooling, duty type S1, continuous duty
for rated voltage, thermal class 155 (F), degree of protection IP 55, 50/60 Hz



Motor selection data															Design point 400 V, 50 Hz 460 V, 60 Hz		
Type	U _B V	f _B Hz	P _B kW	M _B Nm	n _B rpm	η _B IEC/EN 60034-2-1			cosφ _B -	I _B A	I _k /I _B -	M _k /M _B -	M _s /M _B -	M _r /M _B -	J kgm ²	m kg	
						100 %	75 %	50 %									
Synchronous speed 1000 rpm/1200 rpm – 6-pole version																	
IE2-WE2R 63 G6	400	50	0.12	1.3	880	IE2-	50.6	47.0	39.5	0.59	0.59	2.6	2.1	2.1	2.3	0.00027	5.7
	460	60	0.14	1.23	1090	IE2-	50.5	51.0	43.8	0.55	0.60	2.6	1.8	1.8	2.2		
IE2-WE2R 71 K6	400	50	0.18	1.87	920	IE2-	56.6	54.4	48.5	0.52	0.80	2.9	2.0	2.0	2.3	0.0006	8.3
	460	60	0.21	1.8	1115	IE2-	55.0	63.5	57.3	0.52	0.78	2.9	1.6	1.6	2.1		
IE2-WE2R 71 G6	400	50	0.25	2.61	915	IE2-	61.6	57.5	51.6	0.55	1.1	2.9	2.0	2.0	2.2	0.0006	8.3
	460	60	0.30	2.58	1110	IE2-	59.5	62.9	56.7	0.55	1.05	3.1	1.8	1.8	2.2		
IE2-WE2R 80 K6	400	50	0.37	3.78	935	IE2-	67.6	68.5	63.3	0.65	1.17	3.7	2.1	2.1	2.6	0.00175	12.5
	460	60	0.44	3.7	1135	IE2-	64	71.8	67.1	0.66	1.15	4	2	2	2.6		
IE2-WE1R 80 GY6	400	50	0.55	5.56	945	IE2-	73.1	72.6	68.4	0.67	1.62	3.8	1.9	1.9	2.4	0.00325	15
	460	60	0.65	5.49	1130	IE2-	73.0	74	70.2	0.68	1.6	4	2	2	2.2		
IE2-WE2R 90 S6	400	50	0.75	7.58	945	IE2-	75.9	75.5	72.1	0.67	2.12	4.0	1.8	1.8	2.4	0.00425	19
	460	60	0.9	7.51	1145	IE2-	73.0	77.8	74.5	0.68	2.1	4.7	2.1	2.1	2.7		
IE2-WE1R 90 LW6	400	50	1.1	11.0	955	IE2-	78.1	78.0	75.1	0.69	2.95	4.7	2.5	2.4	2.8	0.00625	24
	460	60	-	-	-	-	-	-	-	-	-	-	-	-	-		
IE2-WE2R 100 L6	400	50	1.5	15.1	950	IE2-	79.8	80.4	77.6	0.70	3.85	5.1	2.5	2.4	3.0	0.0072	30
	460	60	0.92	7.5	1180	IE2-	73.0	79.3	75.9	0.5	2.9	5.9	2.9	2.7	3.5		
IE2-WE1R 112 MX6	400	50	2.2	21.9	960	IE2-	81.8	81.9	77.5	0.65	5.9	6.4	3.0	2.9	3.7	0.0139	37
	460	60	-	-	-	-	-	-	-	-	-	-	-	-	-		
IE2-WE1R 132 S6	400	50	3.0	29.8	963	IE2-	83.3	85.2	83.9	0.80	6.40	6.0	2.0	1.3	3.0	0.023	55
	460	60	3.6	29.6	1160	IE2-	87.5	86.8	85.4	0.81	6.4	5.7	1.8	1.2	2.8		
IE2-WE2R 132 M6	400	50	4.0	40.0	955	IE2-	84.6	86.0	85.2	0.82	8.30	5.7	2.1	2.0	2.9	0.029	66
	460	60	4.5	37.2	1155	IE2-	87.5	87.2	86.1	0.82	8	5.7	2.1	1.9	2.9		
IE2-WE1R 132 M6	400	50	4.0	39.6	965	IE2-	85.5	85.5	83.8	0.79	8.5	5.1	1.8	1.6	2.4	0.043	76
	460	60	4.5	36.9	1165	IE2-	87.5	86.0	83.4	0.79	8	5.3	1.8	1.6	2.5		
IE2-WE1R 132 MX6	400	50	5.5	54	970	IE2-	86.1	85.5	82.4	0.77	12	5.7	2.2	1.7	2.7	0.053	85
	460	60	6.6	54	1170	IE2-	89.5	88.5	87.1	0.8	11.5	5.6	1.9	1.7	2.9		

Three-phase motors with squirrel-cage rotor, High Efficiency IE2

with surface cooling, duty type S1, continuous duty
for rated voltage, thermal class 155 (F), degree of protection IP 55, 50/60 Hz

IE2	EU REGULATION 640/2009
	USE WITH VARIABLE SPEED DRIVE ONLY!

Motor selection data															Design point 400 V, 50 Hz 460 V, 60 Hz		
Type	U _B	f _B	P _B	M _B	n _B	IEC/EN 60034-2-1	η _B			cosφ _B	I _B	I _A /I _B	M _A /M _B	M _S /M _B	M _K /M _B	J	m
	V	Hz	kW	Nm	rpm		100 %	75 %	50 %	-	A	-	-	-	-	kgm ²	kg
Synchronous speed 1000 rpm/1200 rpm – 6-pole version																	
IE2-WE1R 160 M6	400	50	7.5	73	975	IE2-	87.4	88.1	86.0	0.81	15.5	6.3	2.5	2.1	2.9	0.113	118
	460	60	9.0	73	1175	IE2-	89.5	88.9	87.0	0.82	16	5.8	2.2	2.0	2.7		
IE2-WE2R 160 M6	400	50	7.5	74	970	IE2-	87.5	87.6	85.9	0.79	15.5	5.9	2.1	1.8	2.9	0.053	103
	460	60	9	73	1170	IE2-	89	89	87.7	0.81	15.5	5.7	1.9	1.7	2.7		
IE2-WE1R 160 L6	400	50	11.0	108	970	IE2-	88.7	87.9	86.3	0.85	21	5.8	2.2	1.9	2.7	0.145	135
	460	60	11.0														
IE2-WE2R 160 L6	400	50	11.0	108	975	IE2-	88.9	88.8	87.0	0.81	22	6.8	2.7	2.4	3.1	0.166	155
	460	60	13	106	1175	IE2-	90.3	89.9	88.1	0.83	22	6.4	2.5	2.2	2.8		
IE2-WE1R 180 L6	400	50	15.0	147	975	IE2-	89.7	88.8	86.7	0.84	28.5	6.2	2.1	1.8	2.8	0.228	185
	460	60	16.5	134	1175	IE2-	90.2	89.8	88.4	0.85	27.0	7.3	2.2	1.9	2.7		
IE2-WE2R 180 L6	400	50	15	148	970	IE2-	89.7	88.8	87.8	0.83	29	5.6	2.3	1.7	2.6	0.166	157
	460	60	15	122	1175	IE2-	90.2	89.5	87.4	0.83	25	6.3	2.5	1.9	2.9		
IE2-WE1R 200 L6	400	50	18.5	180	980	IE2-	90.4	88.8	86.5	0.85	35	6.6	2.3	1.7	2.9	0.268	208
	460	60	22.0	179	1175	IE2-	91.7	90.1	88.5	0.85	35.5	6.6	2.2	1.8	2.7		
IE2-WE1R 200 LX6	400	50	22	214	980	IE2-	90.9	90.2	88.5	0.86	40.5	6.4	2.2	1.8	2.7	0.443	272
	460	60	25	202	1180	IE2-	91.7	91.2	90.0	0.86	40.0	6.4	2.2	1.8	2.7		
IE2-WE2R 200 LX6	400	50	22	215	975	IE2-	90.9	89.9	88.5	0.84	41.5	6.7	2.4	2.0	3.0	0.324	238
	460	60	25	202	1180	IE2-	91.7	90.8	89.5	0.86	40	6.6	2.3	1.9	2.9		
IE2-WE1R 225 M6	400	50	30	291	985	IE2-	92.0	91.5	90.0	0.86	54.5	7.3	2.5	2.2	2.9	0.825	365
	460	60	36	291	1182	IE2-	93.0	92.0	90.5	0.85	57.0	7.1	2.3	2.0	2.6		
IE2-WE2R 225 M6	400	50	30	294	975	IE2-	91.7	91.4	90.6	0.87	54.5	6.7	2.3	1.9	2.8	0.514	308
	460	60	25	201	1185	IE2-	91.7	90.8	88.1	0.86	40	8.2	2.9	2.4	3.7		
IE2-WE1R 250 M6	400	50	37	359	985	IE2-	92.2	91.7	90.7	0.85	68	6.4	2.7	1.8	2.4	1.28	480
	460	60	40	322	1185	IE2-	93.0	92.0	90.5	0.86	63	6.6	2.7	1.8	2.5		
IE2-WE2R 250 M6	400	50	37	361	979	IE2-	92.2	92.3	91.8	0.86	67.5	6.6	2.7	2.0	2.6	0.92	407
	460	60	40	324	1179	IE2-	93	93.4	91.8	0.86	63	6.7	2.7	2.1	2.6		
IE2-WE1R 280 S6	400	50	45	437	983	IE2-	93.0	92.7	92.4	0.87	80.5	6.5	2.2	1.7	2.4	1.48	560
	460	60	49	395	1185	IE2-	93.6	92.4	91.0	0.87	75.5	6.7	2.3	1.9	2.6		
IE2-WE1R 280 M6	400	50	55	531	990	IE2-	93.5	93.5	93.0	0.85	100	7.6	2.0	1.5	2.5	2.63	710
	460	60	64	514	1190	IE2-	94.1	93.5	93.0	0.84	102	8.0	2.1	1.6	2.7		
IE2-WE1R 315 S6	400	50	75	723	990	IE2-	93.9	93.7	93.5	0.87	133	7.8	1.9	1.5	2.5	3.33	804
	460	60	90	722	1190	IE2-	94.1	93.5	93.0	0.87	138	7.5	1.8	1.6	2.5		
IE2-WE1R 315 M6	400	50	90	868	990	IE2-	94.0	94.0	93.5	0.88	157	7.5	1.8	1.5	2.5	3.60	865
	460	60	99	794	1190	IE2-	94.1	94.0	93.5	0.87	152	8.0	2.1	1.6	2.6		
IE2-WE1R 315 MX6	400	50	110	1061	990	IE2-	94.3	94.3	94.0	0.87	194	7.5	1.8	1.4	2.3	6.67	1210
	460	60	110	883	1190	IE2-	95.0	94.6	94.2	0.87	167	8.3	2.0	1.7	2.6		
IE2-WE1R 315 MY6	400	50	132	1273	990	IE2-	94.6	94.3	94.0	0.87	231	7.5	1.9	1.4	2.2	6.67	1250
	460	60	145	1164	1190	IE2-	95.0	95.0	94.5	0.86	223	8.0	2.0	1.5	2.4		
IE2-WE1R 315 L6	400	50	160	1543	990	IE2-	94.8	94.5	93.5	0.88	277	7.5	2.0	1.5	2.4	8.60	1430
	460	60	175	1404	1190	IE2-	95.0	94.8	94.3	0.87	266	8.0	2.0	1.5	2.4		
IE2-WE1R 315 LX6	400	50	200	1929	990	IE2-	95.0	95.0	94.5	0.86	353	7.0	1.9	1.5	2.2	8.60	1460
	460	60	220	1766	1190	IE2-	95.0	95.0	94.5	0.86	338	7.0	1.9	1.5	2.3		
IE2-WE2R 355 M6	400	50	250	2402	994	IE2-	95.0	95.0	94.7	0.84	452	7.0	1.5	1.2	2.2	8.20	1850
	460	60	280	2241	1193	IE2-	95.0	94.5	93.5	0.83	446	8.0	1.7	1.3	2.5		
IE2-WE2R 355 MX6	400	50	315	3023	995	IE2-	95.2	95.2	95.2	0.86	555	7.0	1.3	1.1	2.2	12.1	2200
	460	60	330	2633	1197	IE2-	95.2	95.2	95.2	0.86	506	7.0	1.3	1.1	2.2		
IE2-WE2R 355 LY6	400	50	355	3407	995	IE2-	95.0	95.0	94.0	0.77	700	7.5	1.8	1.5	2.6	14.0	2400
	460	60	375	2997	1195	IE2-	95.0	94.5	93.5	0.76	652	8.0	1.9	1.6	2.8		

Three-phase motors with squirrel-cage rotor, High Efficiency IE2

with surface cooling, duty type S1, continuous duty
for rated voltage, thermal class 155 (F), degree of protection IP 55, 50/60 Hz

Motor selection data															Design point 400 V, 50 Hz 460 V, 60 Hz		
Type	U _B V	f _B Hz	P _B kW	M _B Nm	n _B rpm	η _B IEC/EN 60034-2-1			cosφ _B -	I _B A	I _K /I _B -	M _K /M _B -	M _G /M _B -	M _K /M _B -	J kgm ²	m kg	
						100 %	75 %	50 %									
Synchronous speed 750 rpm/900 rpm – 8-pole version																	
IE2-WE2R 71 G8	400	50	0.12	1.71	670	IE2-	39.8	39.8	31.9	0.54	0.73	2.10	1.80	1.80	2.00	0.0006	8.1
	460	60	0.14	1.62	825	IE2-	40.0	37	30.2	0.52	0.71	2.3	1.9	1.9	2.1		
IE2-WE2R 80 K8	400	50	0.18	2.49	690	IE2-	45.9	52.2	44.0	0.59	0.78	2.70	1.90	1.90	2.20	0.0013	10.5
	460	60	0.21	2.39	840	IE2-	46.0	55.2	48.3	0.61	0.75	2.9	1.5	1.5	2		
IE2-WE2R 80 G8	400	50	0.25	3.43	695	IE2-	50.6	50.4	42.5	0.56	1.12	3.0	2.3	2.3	2.5	0.00175	12
	460	60	0.3	3.41	840	IE2-	52.0	56.1	48.5	0.57	1.09	3	1.9	1.9	2.1		
IE2-WE2R 90 S8	400	50	0.37	5.05	700	IE2-	56.1	57.3	50.7	0.54	1.60	3.00	1.50	1.50	2.00	0.003	15
	460	60	0.44	4.94	850	IE2-	58.0	57.8	52.5	0.55	1.63	3	1.5	1.5	2		
IE2-WE2R 90 L8	400	50	0.55	7.56	695	IE2-	61.7	61.3	54.9	0.60	2.04	3.30	1.50	1.50	2.00	0.00375	18
	460	60	0.65	7.35	845	IE2-	66.0	66.4	61	0.57	2.1	3.1	1.4	1.4	1.9		
IE2-WE2R 100 L8	400	50	0.75	10.2	705	IE2-	66.2	64.5	58.7	0.60	2.90	3.10	1.50	1.50	2.00	0.00625	23
	460	60	0.9	10.11	850	IE2-	66.0	68.7	63	0.59	2.76	3.2	1.4	1.4	1.9		
IE2-WE1R 100 LY8	400	50	1.10	14.9	705	IE2-	70.8	71.2	67.6	0.67	3.25	4.00	2.00	2.00	2.40	0.009	28
	460	60	1.25	14.04	850	IE2-	75.5	76.9	72.7	0.67	3	4.2	1.7	1.7	2.2		
IE2-WE1R 112 MV8	400	50	1.50	20.46	700	IE2-	74.1	78.7	76.0	0.65	4.25	3.8	1.6	1.6	2.1	0.0155	48
	460	60	1.25	13.64	875	IE2-	75.5	77.6	72.7	0.54	3.63	3.8	2	1.9	2.9		
IE2-WE1R 132 M8	400	50	3.0	39.8	720	IE2-	82.7	83.0	81.3	0.74	7.1	3.9	1.6	1.3	1.9	0.0430	74
	460	60	3.6	39.5	870	-	84.2	84.5	83.0	0.75	7.2	3.6	1.4	1.2	1.8		
IE2-WE1R 160 M8	400	50	4.0	53.2	718	IE2-	84.2	83.7	81.9	0.72	9.5	4.6	1.6	***)	2.5	0.0530	86
	460	60	4.0														
IE2-WE1R 160 MX8	400	50	5.5	72.0	730	IE2-	86.9	86.6	84.1	0.72	12.5	4.8	2.1	1.8	2.6	0.1130	115
	460	60	6.6	72	875	-	87.8	87.2	84.6	0.74	12.7	4.9	2.0	1.6	2.4		
IE2-WE2R 160 MX8	400	50	5.5	73	715	IE2-	83.9	84.0	81.9	0.71	13.5	4.3	1.7	1.5	2.5	0.0530	103
	460	60	6.6	73	865	-	86.4	86.7	85.3	0.72	13.5	4.2	1.6	1.4	2.3		
IE2-WE1R 160 L8	400	50	7.5	99	725	IE2-	87.5	87.0	83.5	0.77	16	5.5	2.0	***)	2.8	0.1450	136
	460	60	7.5														

***) upon request

Three-phase motors with squirrel-cage rotor, High Efficiency IE2

with surface cooling, duty type S1, continuous duty
for rated voltage, thermal class 155 (F), degree of protection IP 55, 50/60 Hz

Type	Motor selection data														Design point 400 V, 50 Hz 460 V, 60 Hz		
	U _B	f _B	P _B	M _B	n _B	η _B			cosφ _B	I _B	I _A /I _B	M _A /M _B	M _G /M _B	M _K /M _B	J	m	
	V	Hz	kW	Nm	rpm	IEC/EN 60034-2-1			-	A	-	-	-	-	kgm ²	kg	
						100 %	75 %	50 %									
Synchronous speed 750 rpm/900 rpm – 8-pole version																	
IE2-WE1R 180 L8	400	50	11.0	144	727	IE2-	88.2	88.2	86.7	0.78	23	4.9	1.8	1.6	2.4	0.2280	175
	460	60	13.0	141	878	-	89.4	89.4	87.9	0.78	23.5	4.6	1.7	1.5	2.3		
IE2-WE2R 180 L8	400	50	11	144	730	IE2-	87.9	87.4	85.2	0.67	25.5	4.3	1.9	1.6	2.3	0.1660	157
	460	60	13														
IE2-WE1R 200 L8	400	50	15.0	197	727	IE2-	88.2	88.1	86.4	0.77	32	4.9	1.9	1.7	2.3	0.2680	200
	460	60	18.0	196	878	-	88.9	88.7	87.4	0.78	32.5	4.8	1.8	1.6	2.2		
IE2-WE1R 225 S8	400	50	18.5	242	730	IE2-	89.6	89.4	87.2	0.78	38	5.4	2.1	2.0	2.8	0.440	265
	460	60	22	239	880	-	89.9	89.6	87.5	0.79	39.0	5.2	2.0	1.9	2.7		
IE2-WE2R 225 S8	400	50	18.5	240	735	IE2-	90.7	90.7	89.4	0.8	37	6.1	2.1	1.9	2.9	0.514	305
	460	60	22	237	885	-	91.8	91.5	90.2	0.81	37.0	5.7	2	1.7	2.6		
IE2-WE1R 225 M8	400	50	22	287	733	IE2-	90.6	89.4	89.9	0.78	45	5.6	2.2	1.8	2.6	0.825	380
	460	60	33	356	885	-	91.5	91.0	89.5	0.78	58.0	5.6	2.1	1.8	2.4		
IE2-WE2R 225 M8	400	50	22	286	735	IE2-	90.3	90.3	88.7	0.77	45.5	6.1	2.2	2.0	2.9	0.514	307
	460	60	26	281	883	-	91.3	91.1	89.6	0.79	45.0	5.9	2.1	1.8	2.7		
IE2-WE1R 250 M8	400	50	30	389	737	IE2-	92.1	92.4	91.6	0.79	59.5	5.0	2.0	1.6	2.1	1.350	480
	460	60	37	398	887	-	91.7	91.5	90.0	0.80	63.5	4.7	1.7	1.3	1.8		
IE2-WE2R 250 M8	400	50	30	391	732	IE2-	91.5	91.7	90.9	0.77	61.5	5.6	2.3	2.0	2.5	0.950	405
	460	60	36	391	880	-	91.9	92.3	91.8	0.78	63.0	5.3	2.1	1.8	2.3		
IE2-WE1R 280 S8	400	50	37	479	737	IE2-	92.2	92.1	90.9	0.79	73.5	6.0	2.3	1.9	2.5	1.55	550
	460	60	45	484	888	-	91.7	91.2	89.0	0.79	78.0	6.0	2.1	1.6	2.2		
IE2-WE1R 280 M8	400	50	45	581	740	IE2-	92.7	92.7	92.0	0.79	88.5	6.7	1.8	1.5	2.5	2.63	690
	460	60	45														
IE2-WE1R 315 S8	400	50	55	710	740	IE2-	92.2	92.2	92.1	0.80	108	6.3	1.8	1.5	2.3	2.63	690
	460	60	66	708	890	-	93	93	92.5	0.8	111	5.8	1.6	1.4	2		
IE2-WE1R 315 M8	400	50	75	968	740	IE2-	93.5	93.5	93.0	0.81	143	6.0	1.8	1.5	2.1	3.6	880
	460	60	75														
IE2-WE1R 315 MX8	400	50	90	1161	740	IE2-	92.1	91.6	90.1	0.81	174	6.0	1.9	***)	2.2	6	1050
	460	60	90														
IE2-WE1R 315 MY8	400	50	110	1420	740	IE2-	93.8	93.3	91.2	0.81	209	6.5	2.1	***)	2.4	6.76	1250
	460	60	10														
IE2-WE1R 315 L8	400	50	132	1704	740	IE2-	94.4	94.0	93.5	0.83	243	7.5	2.2	1.8	2.5	8.71	1430
	460	60	132														
IE2-WE1R 315 LX8	400	50	160	2065	740	IE2-	94.2	94.2	93.8	0.80	306	7.2	2.2	1.8	2.5	8.71	1430
	460	60	190	2039	890	-	94.3	94.3	94.0	0.81	312	7.0	2.1	1.7	2.3		
IE2-WE2R 355 M8	400	50	200	2571	743	IE2-	94.7	94.1	91.5	0.77	396			***)		9.5	1850
	460	60	200														
IE2-WE2R 355 MX8	400	50	250	3205	745	IE2-	95.8	95.8	95.5	0.83	454	7.0	1.2	1.0	2.6	13.4	2200
	460	60	250														
IE2-WE2R 355 LY8	400	50	280	3599	743	IE2-	94.8	94.1	91.5	0.78	547			***)		15.8	2400
	460	60	280														

***) upon request

Three-phase motors with squirrel-cage rotor, Standard Efficiency IE1

with surface cooling, duty type S1, continuous duty
for rated voltage, thermal class 155 (F), degree of protection IP 55, 50 Hz



Motor selection data													Design point 400 V, 50 Hz		
Type	P_B	M_B	n_B	η_B			$\cos\phi_B$	I_B	I_A/I_B	M_A/M_B	M_S/M_B	M_K/M_B	J	m	
	kW	Nm	rpm	IEC/EN 60034-2-1			-	400 V	-	-	-	-	kgm ²	kg	
Synchronous speed 3000 rpm – 2-pole version															
IE1-K210 56 K2	0.09	0.3	2840	IE1-	70.2	68.1	64.5	0.74	0.25	4.9	2.3	2.3	2.8	0.00013	4.4
IE1-K21R 56 G2	0.12	0.41	2830	IE1-	70.3	67.0	60.1	0.77	0.32	4.5	2.1	2.1	2.3	0.00013	4.5
IE1-K21R 63 K2	0.18	0.62	2790	IE1-	67.0	65.6	59.8	0.76	0.51	4.1	1.9	1.9	2.2	0.00013	4.9
IE1-K21R 63 G2	0.25	0.85	2800	IE1-	67.7	64.9	56.2	0.72	0.74	4.2	2.2	2.2	2.4	0.00015	5.2
IE1-K21R 71 K2	0.37	1.27	2780	IE1-	71.9	70.8	65.0	0.79	0.94	4.4	2.1	2.1	2.3	0.00025	6.7
IE1-K21R 71 G2	0.55	1.89	2775	IE1-	74.2	75.0	72.0	0.81	1.32	5.1	2.3	2.1	2.6	0.00032	7.6
IE1-K21R 80 K2	0.75	2.54	2825	IE1-	76.8	77.5	74.3	0.82	1.72	5.9	2.4	2.4	2.4	0.00057	10.7
IE1-K21R 80 G2	1.1	3.71	2835	IE1-	76.9	75.9	73.3	0.81	2.55	6.0	2.4	2.3	2.6	0.00072	11.5
IE1-K21R 90 S2	1.5	5	2840	IE1-	81.2	82.2	80.3	0.86	3.1	7.0	2.5	2.5	2.8	0.00132	16.0
IE1-K21R 90 L2	2.2	7.4	2850	IE1-	82.1	83.4	81.9	0.85	4.55	7.5	2.8	2.3	2.9	0.0017	19.0
IE1-K21R 100 L2	3.0	10	2865	IE1-	82.8	83.1	83.3	0.85	6.15	6.8	2.4	2.2	2.8	0.00275	25.0
IE1-K21R 112 M2	4.0	13.2	2900	IE1-	84.9	85.5	84.4	0.81	8.4	7.0	2.2	2.1	2.9	0.0045	32
IE1-K21R 132 S2 T	5.5	18.2	2890	IE1-	85.9	86.2	86.4	0.84	11.0	7.5	2.4	2.2	3.0	0.0055	40
IE1-K21R 132 SX2T	7.5	24.9	2880	IE1-	87.1	87.2	86.6	0.84	14.8	6.3	1.5	1.2	2.6	0.0680	48
IE1-K21R 132 S2	5.5	18.3	2870	IE1-	84.7	85.3	84.9	0.86	11	5.1	1.6	1.4	2.3	0.0081	50
IE1-K21R 132 SX2	7.5	24.8	2890	IE1-	86.1	86.9	85.8	0.85	15	6.5	1.9	1.6	3.0	0.0110	59
IE1-K21R 160 M2	11.0	36.2	2905	IE1-	87.6	87.4	86.6	0.88	20.5	6.6	2.1	1.7	2.8	0.0258	88
IE1-K21R 160 MX2	15.0	48.7	2940	IE1-	88.7	89.0	88.0	0.89	27.5	6.8	2.0	1.5	2.6	0.0575	131
IE1-K21R 160 L2	18.5	60	2925	IE1-	89.3	89.2	88.9	0.90	33	6.0	1.7	1.3	2.2	0.0675	138
IE1-K21R 180 M2	22	72	2935	IE1-	89.9	91.1	90.5	0.90	39	5.4	1.6	1.3	2.4	0.105	178
IE1-K21R 200 L2	30	97	2940	IE1-	90.7	92.1	91.8	0.91	52.5	6.3	1.5	1.2	2.4	0.128	207
IE1-K21R 200 LX2	37	120	2950	IE1-	91.2	92.1	91.9	0.89	66	5.8	1.4	1.0	2.2	0.193	265
IE1-K21R 225 M2	45	146	2940	IE1-	91.7	92.6	92.5	0.90	78.5	6.2	1.4	1.1	2.3	0.220	295
IE1-K21R 250 M2	55	177	2960	IE1-	92.4	92.0	90.0	0.90	95.5	7.2	1.7	1.3	2.5	0.375	383
IE1-K21R 280 S2	75	241	2970	IE1-	93.5	92.4	90.5	0.92	126	7.1	1.9	1.5	2.5	0.650	505
IE1-K21R 280 M2	90	289	2970	IE1-	93.2	92.7	90.5	0.91	153	8.4	2.2	1.8	3.1	0.675	546
IE1-K21R 315 S2	110	353	2975	IE1-	93.5	93.8	93.5	0.90	189	8.5	1.2	1.0	2.3	1.21	720
IE1-K21R 315 M2	132	424	2975	IE1-	93.8	93.8	93.8	0.91	223	8.0	1.4	1.2	2.5	1.44	800
IE1-K21R 315 MX2	160	514	2975	IE1-	94.0	94.0	94.0	0.91	270	8.5	1.5	1.0	2.0	1.76	980
IE1-K21R 315 MY2	200	965	2970	IE1-	94.5	94.5	94.0	0.91	336	8.2	2.6	1.8	2.6	2.82	1170
IE1-K21R 315 L2	250	803	2973	IE1-	94.1	93.2	93.0	0.93	412	7.3	2.1	1.4	2.0	3.66	1460
IE1-K21R 315 LX2	315	1008	2985	IE1-	94.5	94.5	94.5	0.92	523	8.6	2.7	1.7	2.4	4.43	1630
IE1-K22R 355 MY2	315	1007	2988	IE1-	94.5	94.3	93.7	0.88	547	8.6	1.3	1.0	3.0	4.10	1900
IE1-K22R 355 M2	355	1138	2980	IE1-	94.3	94.3	93.8	0.91	597	7.3	1.3	1.0	2.3	4.20	2000
IE1-K22R 355 MX2	400	1278	2990	IE1-	95.0	95.0	95.0	0.90	675	9.5	1.9	1.0	3.0	5.50	2200
IE1-K22R 355 LY2	450	1441	2983	IE1-	94.7	94.5	93.8	0.92	746	7.2	1.3	1.0	2.4	7.10	2400
IE1-K22R 355 L2	500	1600	2985	IE1-	95.0	94.8	94.3	0.92	826	8.2	1.8	0.9	2.6	7.10	2400

Three-phase motors with squirrel-cage rotor, Standard Efficiency IE1

with surface cooling, duty type S1, continuous duty
for rated voltage, thermal class 155 (F), degree of protection IP 55, 50 Hz



Motor selection data													Design point 400 V, 50 Hz		
Type	P_B	M_B	n_B		η_B			$\cos\phi_B$	I_B	I_A/I_B	M_A/M_B	M_S/M_B	M_K/M_B	J	m
	kW	Nm	rpm		IEC/EN 60034-2-1			-	400 V	-	-	-	-	kgm ²	kg
Synchronous speed 1500 rpm – 4-pole version															
IE1-K210 56 K4	0.06	0.41	1410	IE1-	60.1	56.5	49.6	0.60	0.24	3.1	2.3	2.3	2.7	0.00019	4.3
IE1-K21R 56 G4	0.09	0.63	1375	IE1-	61.6	58.7	53.0	0.68	0.31	3.2	1.9	1.9	2.2	0.00019	4.4
IE1-K21R 63 K4	0.12	0.84	1370	IE1-	57.9	51.2	42.2	0.68	0.44	3.2	1.9	1.8	2.2	0.00019	4.8
IE1-K21R 63 G4	0.18	1.26	1360	IE1-	60.6	57.5	49.4	0.66	0.65	3.3	2.0	2.0	2.3	0.00024	5.2
IE1-K21R 71 K4	0.25	1.72	1385	IE1-	64.3	63.2	58.2	0.72	0.78	3.6	1.8	1.8	2.1	0.00040	6.8
IE1-K21R 71 G4	0.37	2.58	1370	IE1-	68.1	66.7	62.0	0.74	1.06	3.8	2.0	2.0	2.2	0.00050	7.8
IE1-K21R 80 K4	0.55	3.75	1400	IE1-	71.9	70.7	64.1	0.69	1.6	4.1	2.1	2.0	2.3	0.00087	10.6
IE1-K21R 80 G4	0.75	5.1	1400	IE1-	73.6	72.2	66.8	0.70	2.1	4.6	2.2	2.1	2.3	0.00107	11.7
IE1-K21R 90 S4	1.1	7.5	1410	IE1-	76.7	76.8	73.6	0.79	2.62	5.5	2.3	2.2	2.5	0.00207	15.5
IE1-K21R 90 L4	1.5	10.2	1400	IE1-	78.6	79.1	76.9	0.81	3.4	5.5	2.5	2.4	2.6	0.00260	18.0
IE1-K21R 100 L4	2.2	14.9	1410	IE1-	80.2	80.7	79.5	0.80	4.95	6.0	2.5	2.3	2.7	0.00400	23.5
IE1-K21R 100 LX4	3.0	20	1430	IE1-	82.4	82.8	80.8	0.79	6.65	6.5	2.5	2.2	2.9	0.00725	30
IE1-K21R 112 M4	4.0	26.6	1435	IE1-	84.1	85.1	83.6	0.78	8.8	6.9	2.6	2.5	3.2	0.009	37
IE1-K21R 132 S4 T	5.5	36.9	1425	IE1-	85.2	86.5	85.8	0.79	11.8	6.3	2.5	2.4	2.9	0.011	47
IE1-K21R 132 S4	5.5	36.5	1440	IE1-	84.7	85.5	84.9	0.87	11	6.2	1.8	1.5	2.7	0.015	51
IE1-K21R 132 M4	7.5	49.2	1455	IE1-	86.2	86.9	86.7	0.83	15	5.4	1.9	1.2	2.5	0.028	73
IE1-K21R 160 M4	11.0	72	1455	IE1-	87.7	88.5	87.8	0.84	21.5	6.5	2.1	1.6	3.0	0.035	92
IE1-K21R 160 L4	15.0	98	1465	IE1-	88.7	88.8	87.9	0.84	29	6.6	2.3	1.7	2.6	0.078	132
IE1-K21R 180 M4	18.5	121	1460	IE1-	89.3	88.8	88.1	0.85	35	6.4	2.2	1.8	2.6	0.090	145
IE1-K21R 180 L4	22	143	1465	IE1-	89.9	90.1	89.5	0.82	43	5.4	1.5	1.3	2.2	0.138	185
IE1-K21R 200 L4	30	196	1465	IE1-	90.7	90.5	89.8	0.84	57	5.6	1.7	1.4	2.3	0.168	211
IE1-K21R 225 S4	37	240	1470	IE1-	92.1	92.6	92.0	0.83	69.5	6.1	1.8	1.4	2.3	0.275	282
IE1-K21R 225 M4	45	293	1465	IE1-	91.7	91.8	91.9	0.84	84.5	5.8	1.5	1.3	2.2	0.313	323
IE1-K21R 250 M4	55	356	1475	IE1-	92.4	92.0	91.0	0.84	102	7.0	2.0	1.6	2.2	0.525	394
IE1-K21R 280 S4	75	484	1480	IE1-	93.0	92.6	90.6	0.84	139	7.0	2.0	1.5	2.2	0.950	540
IE1-K21R 280 M4	90	581	1480	IE1-	93.3	92.8	90.0	0.85	164	7.3	1.8	1.5	2.1	1.10	610
IE1-K21R 315 S4	110	707	1485	IE1-	93.5	93.5	93.5	0.85	200	7.5	1.8	1.3	2.2	1.96	740
IE1-K21R 315 M4	132	849	1485	IE1-	93.8	93.8	93.8	0.86	236	7.0	1.8	1.5	2.2	2.27	840
IE1-K21R 315 MX4	160	1032	1480	IE1-	93.8	93.8	93.8	0.86	286	7.0	1.5	1.3	2.0	2.73	1000
IE1-K21R 315 MY4	200	1286	1485	IE1-	94.3	94.3	94.3	0.87	352	7.5	1.8	1.5	2.4	4.82	1200
IE1-K21R 315 L4	250	1608	1485	IE1-	94.3	94.3	94.3	0.89	430	8.0	1.7	1.3	2.3	5.93	1510
IE1-K21R 315 LX4	315	2023	1487	IE1-	94.5	94.5	94.5	0.88	547	8.6	1.9	1.5	2.3	6.82	1630
IE1-K22R 355 MY4	315	2016	1492	IE1-	94.5	94.5	94.5	0.87	553	7.1	1.4	1.0	2.9	5.60	1950
IE1-K22R 355 M4	355	2271	1493	IE1-	94.5	94.5	93.2	0.87	623	8.1	1.3	0.8	2.7	7.9	2150
IE1-K22R 355 MX4	400	2557	1494	IE1-	94.5	94.4	93.7	0.84	727	8.6	1.3	1.0	3.0	9.5	2400
IE1-K22R 355 LY4	450	2884	1490	IE1-	94.5	94.4	93.7	0.82	838	8.0	1.2	1.0	3.0	10.0	2500
IE1-K22R 355 L4	500	3205	1490	IE1-	94.3	94.0	93.1	0.79	969	7.9	1.1	1.0	3.0	10.00	2500

Three-phase motors with squirrel-cage rotor, Standard Efficiency IE1

with surface cooling, duty type S1, continuous duty
for rated voltage, thermal class 155 (F), degree of protection IP 55, 50 Hz



Motor selection data														Design point 400 V, 50 Hz		
Type		P _B	M _B	n _B		η _B			cosφ _B	I _B	I _A /I _B	M _A /M _B	M _S /M _B	M _K /M _B	J	m
						IEC/EN 60034-2-1				400 V						
		kW	Nm	rpm		100 %	75 %	50 %	-	A	-	-	-	-	kgm ²	kg
Synchronous speed 1000 rpm – 6-pole version																
IE1-K21R 63 K6	IE1-K20R 56 K6	0.09	0.96	895	-	50.4	46.2	38.4	0.56	0.46	2.5	2.0	2.0	2.4	0.00024	4.9
IE1-K21R 63 G6	IE1-K20R 56 G6	0.12	1.3	880	-	52.4	50.1	43.2	0.56	0.59	2.5	2.0	2.0	2.3	0.00027	5.7
IE1-K21R 71 K6	IE1-K20R 63 K6	0.18	1.86	925	-	57.9	53.9	45.4	0.51	0.88	2.8	1.6	1.6	2.1	0.00045	7.4
IE1-K21R 71 G6	IE1-K20R 63 G6	0.25	2.61	915	-	59.6	57.5	49.5	0.55	1.1	2.9	2.0	2.0	2.2	0.00060	8.3
IE1-K21R 80 K6	IE1-K20R 71 K6	0.37	3.86	915	-	66.3	64.5	57.1	0.66	1.22	3.4	2.0	2.0	2.0	0.00130	11.0
IE1-K21R 80 G6	IE1-K20R 71 G6	0.55	5.7	915	-	68.5	67.0	60.7	0.67	1.73	3.7	2.2	2.2	2.4	0.00175	12.5
IE1-K21R 90 S6	IE1-K20R 80 K6	0.75	7.7	935	IE1-	70.5	68.8	63.2	0.64	2.4	4.5	2.4	2.4	2.6	0.00325	16.0
IE1-K21R 90 L6	IE1-K20R 80 G6	1.1	11.2	935	IE1-	73.4	73.0	68.4	0.68	3.18	4.6	2.2	2.2	2.6	0.00425	19.0
IE1-K21R 100 L6	IE1-K20R 90 L6	1.5	15.2	945	IE1-	76.0	75.2	71.1	0.73	3.9	4.6	2.1	2.0	2.4	0.00625	24.0
IE1-K21R 112 M6	IE1-K20R 100 L6	2.2	22.1	950	IE1-	78.1	78.8	75.8	0.76	5.35	5.3	2.2	2.1	2.7	0.01225	33.5
IE1-K21R 132 S6T		3.0	30.6	935	IE1-	81.9	82.8	81.4	0.75	7.05	5.2	2.5	2.5	2.9	0.0139	39.0
IE1-K21R 132 S6	IE1-K20R 112 M6	3.0	30	955	IE1-	80.3	79.9	76.2	0.78	6.9	5.3	1.9	1.8	2.8	0.0180	46
IE1-K21R 132 M6	IE1-K20R 112 MX6	4.0	40	955	IE1-	81.9	81.8	75.4	0.79	8.9	5.7	2.1	1.9	2.9	0.0230	56
IE1-K21R 132 MX6	IE1-K20R 132 S6	5.5	55	960	IE1-	83.1	83.3	81.3	0.79	12	4.8	1.7	1.5	2.4	0.0430	72
IE1-K21R 160 M6	IE1-K20R 132 M6	7.5	75	960	IE1-	84.8	84.9	80.0	0.78	16.5	4.9	1.8	1.5	2.4	0.0530	91
IE1-K21R 160 L6	IE1-K20R 160 S6	11.0	109	965	IE1-	86.4	86.6	84.2	0.84	22	5.1	2.1	1.6	2.2	0.1130	122
IE1-K21R 180 L6	IE1-K20R 160 M6	15.0	148	970	IE1-	87.7	85.9	83.7	0.80	31	5.7	2.2	1.9	2.6	0.1450	142
IE1-K21R 200 L6	IE1-K20R 180 S6	18.5	182	970	IE1-	88.6	88.1	87.1	0.86	35	5.3	1.8	1.5	2.3	0.2280	190
IE1-K21R 200 LX6	IE1-K20R 180 M6	22	216	972	IE1-	89.2	88.8	87.3	0.85	42	5.6	2.0	1.7	2.6	0.2680	208
IE1-K21R 225 M6	IE1-K20R 200 M6	30	295	973	IE1-	90.2	90.1	89.2	0.87	55	6.1	2.0	1.6	2.5	0.4430	284
IE1-K21R 250 M6	IE1-K20R 225 M6	37	361	979	IE1-	91.0	90.6	87.8	0.86	68	6.3	2.2	1.8	2.4	0.8250	376
IE1-K21R 280 S6	IE1-K20R 250 S6	45	439	980	IE1-	91.5	92.0	89.4	0.86	82.5	5.9	2.0	1.6	2.2	1.28	465
IE1-K21R 280 M6	IE1-K20R 250 M6	55	535	982	IE1-	92.1	91.5	89.4	0.87	99	6.5	2.3	1.7	2.4	1.48	575
IE1-K21R 315 S6	IE1-K20R 280 S6	75	727	985	IE1-	92.7	92.0	91.0	0.87	134	7.0	1.8	1.4	2.1	2.63	690
IE1-K21R 315 M6	IE1-K20R 280 M6	90	868	990	IE1-	93.4	93.4	93.0	0.87	160	7.0	2.0	1.7	2.4	3.33	800
IE1-K21R 315 MX6	IE1-K20R 315 S6	110	1067	985	IE1-	93.3	93.3	93.3	0.87	196	6.5	2.0	1.6	2.4	3.60	880
IE1-K21R 315 MY6	IE1-K20R 315 M6	132	1273	990	IE1-	93.5	93.5	93.5	0.87	234	7.0	1.8	1.4	2.1	6.00	1050
IE1-K21R 315 L6	IE1-K20R 315 L6	160	1548	987	IE1-	93.8	93.5	93.0	0.87	283	6.5	1.7	1.2	2.0	6.67	1250
IE1-K21R 315 LX6	IE1-K20R 315 LX6	200	1929	990	IE1-	94.0	94.0	94.0	0.86	357	8.0	2.2	1.5	2.3	8.6	1460
IE1-K22R 355 MY6		200	1920	995	IE1-	94.4	94.4	94.4	0.84	364	7.0	1.5	1.3	2.4	8.1	1550
IE1-K22R 355 M6		250	2402	994	IE1-	94.5	94.2	93.3	0.81	471	7.0	1.8	1.3	2.3	8.2	1850
IE1-K22R 355 MX6		315	3023	995	IE1-	94.5	94.5	93.8	0.83	580	6.8	1.6	1.3	2.5	12.1	2200
IE1-K22R 355 LY6		355	3407	995	IE1-	94.4	94.2	92.4	0.78	696	7.4	1.9	1.4	2.6	14.0	2400

Three-phase motors with squirrel-cage rotor, Standard Efficiency IE1

with surface cooling, duty type S1, continuous duty
for rated voltage, thermal class 155 (F), degree of protection IP 55, 50 Hz



Motor selection data														Design point 400 V, 50 Hz		
Type	P_B	M_B	n_B	η_B			$\cos\phi_B$	I_B	I_A/I_B	M_A/M_B	M_S/M_B	M_K/M_B	J	m		
	kW	Nm	rpm	IEC/EN 60034-2-1			-	400 V	-	-	-	-	kgm ²	kg		
Synchronous speed 750 rpm – 8-pole version																
K21R 71 K8	K20R 63 K8	0.09	1.27	675	-	45.5	42.1	34.8	0.51	0.56	2.1	1.9	1.9	2.1	0.00050	6.6
K21R 71 G8	K20R 63 G8	0.12	1.71	670	-	46.5	42.1	33.7	0.51	0.73	2.3	1.8	1.8	2.1	0.00060	8.1
K21R 80 K8	K20R 71 K8	0.18	2.49	690	-	56.5	53.4	45.0	0.59	0.78	2.8	2.0	2.0	2.2	0.00130	10.5
K21R 80 G8	K20R 71 G8	0.25	3.44	695	-	57.5	54.1	46.1	0.56	1.12	3.0	2.3	2.3	2.5	0.00175	12.0
K21R 90 S8	K20R 80 K8	0.37	5.1	700	-	61.8	59.7	52.8	0.54	1.60	3.0	1.9	1.9	2.1	0.00300	15.0
K21R 90 L8	K20R 80 G8	0.55	7.6	695	-	64.8	62.5	55.8	0.60	2.04	3.2	1.9	1.9	2.2	0.00375	18.0
K21R 100 L8	K20R 90 L8	0.75	10.2	705	-	66.8	64.7	57.9	0.60	2.70	3.3	1.8	1.8	2.2	0.00625	23.0
K21R 100 LX8	K20R 100 S8	1.1	14.9	705	-	72.9	73.3	69.6	0.67	3.25	4.0	2.0	2.0	2.4	0.00900	28.0
K21R 112 M8	K20R 100 L8	1.5	20.3	705	-	75.4	75.7	72.4	0.70	4.10	4.4	2.2	2.1	2.5	0.01225	33.5
K21R 132 S8T		2.2	30.7	685	-	74.1	74.8	72.4	0.68	6.30	3.8	2.0	1.9	2.3	0.01390	39.0
K21R 132 S8	K20R 112 M8	2.2	29.8	705	-	75.5	75.0	72.0	0.76	5.5	4.5	1.7	1.6	2.3	0.01800	46
K21R 132 M8	K20R 112 MX8	3.0	40.6	705	-	78.0	78.0	75.0	0.75	7.4	4.5	1.7	1.6	2.3	0.0230	53
K21R 160 M8	K20R 132 S8	4.0	54	710	-	79.3	79.0	77.0	0.78	9.3	4.0	1.6	1.3	1.9	0.0430	70
K21R 160 MX8	K20R 132 M8	5.5	74	710	-	81.4	81.0	78.0	0.78	12.5	4.5	1.7	1.6	2.1	0.0530	86
K21R 160 L8	K20R 160 S8	7.5	99	725	-	83.0	83.0	79.0	0.78	16.5	4.5	1.8	1.6	2.1	0.1130	114
K21R 180 L8	K20R 160 M8	11.0	146	720	-	85.0	84.0	81.5	0.78	24	4.5	2.0	1.7	2.1	0.1450	136
K21R 200 L8	K20R 180 S8	15.0	198	725	-	86.5	86.0	83.0	0.79	31.5	5.0	2.0	1.7	2.3	0.228	175
	K20R 180 M8	18.5	244	725	-	87.5	86.5	86.0	0.80	38	5.0	1.9	1.7	2.2	0.268	200
K21R 225 S8		18.5	244	725	-	89.2	88.0	86.0	0.83	36	5.5	2.0	1.6	2.2	0.440	265
K21R 225 M8	K20R 200 M8	22	290	725	-	89.2	89.0	88.5	0.84	42.5	5.0	1.8	1.5	2.2	0.440	265
K21R 250 M8	K20R 225 M8	30	393	730	-	89.7	89.5	86.5	0.79	61	5.5	2.2	1.8	2.2	0.825	360
K21R 280 S8	K20R 250 S8	37	481	735	-	90.5	90.0	87.5	0.80	74	5.5	2.0	1.5	2.0	1.35	465
K21R 280 M8	K20R 250 M8	45	585	735	-	91.0	90.5	88.0	0.77	92.5	6.0	2.3	1.8	2.4	1.55	520
K21R 315 S8	K20R 280 S8	55	710	740	-	92.1	91.0	89.5	0.80	108	6.5	1.8	1.6	2.3	2.63	690
K21R 315 M8	K20R 280 M8	75	968	740	-	92.3	92.0	90.5	0.81	145	6.0	2.0	1.6	2.3	3.33	800
K21R 315 MX8	K20R 315 S8	90	1162	740	-	92.5	92.0	90.5	0.81	173	6.0	1.9	1.6	2.2	3.60	880
K21R 315 MY8	K20R 315 M8	110	1420	740	-	93.6	93.0	91.0	0.81	209	6.5	2.1	1.8	2.4	6.00	1100
K21R 315 L8	K20R 315 L8	132	1704	740	-	94.0	93.3	91.0	0.83	244	6.3	2.0	1.7	2.1	6.76	1250
K21R 315 LX8	K20R 315 LX8	160	2065	740	-	94.2	93.5	91.0	0.79	310	7.2	2.2	1.9	2.5	8.71	1430
K22R 355 MY8		160	2054	744	-	93.5	93.3	92.5	0.80	309	6.8	1.3	1.0	2.5	9.3	1700
K22R 355 M8		200	2571	743	-	93.9	93.6	92.8	0.77	399	6.5	1.6	1.0	2.7	9.5	1850
K22R 355 MX8		250	3209	744	-	94.1	93.9	92.8	0.78	492	6.6	1.3	1.0	2.8	13.4	2200
K22R 355 LY8		280	3594	744	-	93.6	93.4	92.3	0.78	554	8.2	1.2	1.0	2.8	15.8	2400

Three-phase motors with squirrel-cage rotor

with surface cooling, duty type S1, continuous duty
Thermal class 155, degree of protection IP 55

Motor selection data												Design point 400 V, 50 Hz	
Type		P _B	M _B	n _B	η _B	cosφ _B	I _B	I _A /I _B	M _A /M _B	M _S /M _B	M _K /M _B	J	m
		kW	Nm	rpm	%	-	400 V A	-	-	-	-	kgm ²	kg
Synchronous speed 600 rpm – 10-pole version													
K21R 80 K10	K20R 71 K10	0.09	1.56	550	35.7	0.56	0.65	2.2	1.7	1.7	1.9	0.00130	11
K21R 80 G10	K20R 71 G10	0.12	2.10	545	43.9	0.58	0.68	2.2	1.6	1.6	1.8	0.00175	13
K21R 90 S10	K20R 80 K10	0.18	3.10	555	50.9	0.51	1.00	2.3	1.6	1.6	1.8	0.00325	16
K21R 90 L10	K20R 80 G10	0.25	4.30	555	49.1	0.49	1.50	2.3	1.5	1.5	1.9	0.00425	19
K21R 100 L10	K20R 90 L10	0.37	6.48	545	53.0	0.53	1.90	2.9	1.5	1.5	1.9	0.00625	24
K21R 100 LX10	K20R 100 S10	0.55	9.21	570	71.7	0.49	2.26	3.1	1.6	1.6	1.9	0.00900	28
K21R 112 M10	K20R 100 L10	0.75	13.1	545	61.2	0.61	2.90	3.4	1.7	1.7	1.9	0.01225	34
K21R 112 MX10	K20R 100 LX10	1.10	19.1	550	67.6	0.61	3.85	3.1	1.4	1.4	2.0	0.01390	37.0
K21R 132 S10	K20R 112 M10	1.1	18.4	570	67.0	0.65	3.6	3.7	1.7	1.6	2.5	0.0180	46
K21R 132 M10	K20R 112 MX10	1.5	25.1	570	71.5	0.65	4.7	3.8	1.8	1.8	2.6	0.0230	53
K21R 132 MX10	K20R 132 S10	2.2	36.5	575	75.0	0.65	6.5	3.7	1.7	1.6	2.2	0.0430	70
K21R 160 M10	K20R 132 M10	3.0	49.8	575	77.0	0.65	8.7	3.7	1.8	1.7	2.2	0.0530	86
K21R 160 L10	K20R 160 S10	5.5	91.3	575	80.5	0.68	14.5	4.0	1.8	1.7	2.1	0.113	114
K21R 180 L10	K20R 160 M10	6.0	99.7	575	82.0	0.68	15.5	3.9	2.0	1.7	2.1	0.145	136
K21R 200 L10	K20R 180 S10	9.0	147	585	83.0	0.65	24.0	4.6	2.3	2.0	2.7	0.228	175
K21R 200 LX10	K20R 180 M10	13	216	575	85.0	0.70	31.5	4.2	1.8	1.6	2.1	0.268	200
K21R 225 M10	K20R 200 M10	17	280	580	85.0	0.70	41	4.3	1.7	1.5	2.1	0.440	265
K21R 250 M10	K20R 225 M10	22	362	580	87.0	0.69	53	3.9	1.9	1.5	1.6	0.825	360
K21R 280 S10	K20R 250 S10	27	441	585	89.5	0.70	62	4.2	1.9	1.4	1.7	1.35	465
K21R 280 M10	K20R 250 M10	34	555	585	89.0	0.71	77.5	4.5	2.0	1.5	2.0	1.55	520
K21R 315 S10	K20R 280 S10	45	728	590	91.0	0.75	95	5.2	1.5	1.5	2.3	2.63	690
K21R 315 M10	K20R 280 M10	55	887	592	92.0	0.74	117	6.3	1.7	1.7	2.7	3.33	800
K21R 315 MX10	K20R 315 M10	75	1214	590	92.0	0.75	157	5.5	1.5	1.5	2.2	3.60	880
K21R 315 L10	K20R 315 L10	90	1449	593	93.0	0.69	202	6.0	1.8	1.5	2.2	6.76	1250
K21R 315 LX10	K20R 315 LX10	110	1765	595	93.5	0.66	257	6.0	1.6	1.5	2.1	8.71	1430
K22R 355 MY10		110	1766	595	94.7	0.74	227	5.3	0.9	0.8	2.3	9.3	1500
K22R 355 M10		132	2119	595	94.8	0.66	305	5.5	1.1	1.0	2.6	9.5	1600
K22R 355 MX10		160	2568	595				***)				9.5	1600
K22R 355 LY10		180	2889	595	95.3	0.74	370	5.7	1.3		2.4	11.6	2100
K22R 355 L10		200	3210	595	94.3	0.72	425	6.0	1.3	1.0	2.5	15.8	2400
Synchronous speed 500 rpm – 12-pole version													
K21R 80 K12	K20R 71 K12	0.1	1.95	440	31.1	0.58	0.72	1.9	1.6	1.6	2.0	0.0	11.0
K21R 80 G12	K20R 71 G12	0.1	2.58	445	42.4	0.47	0.87	2.0	1.9	1.9	2.1	0.0	12.5
K21R 90 S12	K20R 80 K12	0.18	3.82	450	39.2	0.51	1.30	1.8	1.6	1.6	1.9	0.00325	16.0
K21R 90 L12	K20R 80 G12	0.25	5.31	450	44.6	0.49	1.65	2.0	1.5	1.5	1.7	0.00425	19.0
K21R 100 L12	K20R 90 L12	0.37	7.85	450	50.6	0.48	2.20	2.1	1.5	1.5	1.7	0.00625	24.0
K21R 100 LX12	K20R 100 S12	0.55	11.5	455	53.5	0.53	2.80	2.4	1.4	1.4	1.9	0.00900	28.0
K21R 112 M12	K20R 100 L12	0.75	15.9	450	57.1	0.55	3.45	2.5	1.4	1.4	2.0	0.01225	33.5
K21R 132 S12	K20R 112 M12	0.75	15.1	475	60.0	0.57	3.2	3.0	2.2	2.0	2.2	0.0180	46
K21R 132 M12	K20R 112 MX12	1.1	22.4	470	63.0	0.60	4.2	3.2	1.6	1.6	2.4	0.0230	53
K21R 132 MX12	K20R 132 S12	1.5	29.8	480	67.0	0.57	5.7	3.0	1.5	1.5	2.1	0.0430	70
K21R 160 M12	K20R 132 M12	2.2	44.2	475	69.5	0.55	8.3	3.3	1.9	1.8	2.4	0.0530	86
K21R 160 L12	K20R 160 S12	3.0	59.7	480	77.0	0.60	9.4	3.4	2.0	1.7	2.0	0.113	114
K21R 180 L12	K20R 160 M12	5.5	111	475	76.0	0.60	17.5	3.0	1.8	1.7	2.0	0.145	136
K21R 200 L12	K20R 180 S12	6.0	119	480	83.0	0.65	16	3.3	1.6	1.5	1.9	0.228	175
K21R 200 LX12	K20R 180 M12	9.0	179	480	82.0	0.61	26	3.8	1.9	1.8	2.2	0.268	200
K21R 225 M12	K20R 200 M12	13	259	480	83.0	0.68	33	3.6	1.7	1.5	1.9	0.440	265
K21R 250 M12	K20R 225 M12	17	338	480	86.0	0.69	41.5	3.9	1.7	1.5	1.9	0.825	360
K21R 280 S12	K20R 250 S12	20	392	487	88.0	0.68	48	3.8	1.8	1.4	1.7	1.35	465
K21R 280 M12	K20R 250 M12	24	470	488	87.5	0.63	63	4.0	2.1	1.6	1.9	1.55	520
K21R 315 S12	K20R 280 S12	37	721	490	91.0	0.71	82.5	4.2	1.2	1.1	2.0	2.63	690
K21R 315 M12	K20R 280 M12	45	877	490	91.0	0.72	99	4.5	1.2	1.2	1.9	3.33	800
K21R 315 MX12	K20R 315 M12	55	1083	485	91.0	0.74	118	4.5	1.3	1.1	1.9	3.60	880
K21R 315 L12	K20R 315 L12	75	1450	494	92.0	0.55	215	4.5	1.5	1.2	1.9	6.76	1250
K21R 315 LX12	K20R 315 LX12	90	1747	492	93.3	0.67	208	5.0	1.6	1.5	2.2	8.71	1430
K22R 355 MY12		90	1754	490				***)				9.3	1500
K22R 355 M12		110	2122	495	91.7	0.53	327	4.0	1.3	1.0	1.6	9.3	1850
K22R 355 MX12		132	2573	495				***)				9.5	1600
K22R 355 LY12		145	2826	495				***)				15.8	2400
K22R 355 L12		160	3087	495	93.9	0.60	410	4.0	1.1	0.9	1.6	15.8	2400

Low voltage electrical machines

Three-phase motors with squirrel-cage rotor

with surface cooling, duty type S1, continuous duty
Thermal class 155, degree of protection IP 55

Motor selection data											Design point 400 V, 50 Hz		
Type		P_B	M_B	n_B	η_B	$\cos\phi_B$	I_B	I_A/I_B	M_A/M_B	M_S/M_B	M_K/M_B	J	m
		kW	Nm	rpm	%	-	A	-	-	-	-	kgm ²	kg
Synchronous speed 375 rpm – 16-pole version													
K21R 132 S16	K20R 112 M16	0.55	15.0	350	42.0	0.43	4.4	2.0	1.8		2.3	0.0180	46
K21R 132 M16	K20R 112 MX16	0.75	20.5	350	45.0	0.43	5.6	2.0	1.7		2.2	0.0230	53
K21R 160 M16	K20R 132 S16	0.9	24.2	355	49.0	0.38	7.0	2.0	1.3		1.9	0.0430	70
K21R 160 MX16	K20R 132 M16	1.1	29.6	355	51.0	0.37	8.4	2.0	1.4		1.9	0.0530	86
K21R 160 L16	K20R 160 S16	1.5	39.8	360	58.0	0.40	9.3	2.5	1.5		2.2	0.113	114
K21R 180 L16	K20R 160 M16	2.2	58.3	360	65.0	0.44	11.0	2.5	1.4		1.9	0.145	136
K21R 200 L16	K20R 180 S16	3.0	79.6	360	71.0	0.40	15.0	2.8	1.5		2.2	0.228	175
K21R 200 LX16	K20R 180 M16	4.0	106	360	73.0	0.40	20.0	2.8	1.4		2.0	0.268	200
K21R 225 M16	K20R 200 M16	5.5	144	365	74.0	0.41	26.0	2.8	1.3		2.0	0.440	265
K21R 250 M16	K20R 225 M16	7.5	196	365	75.0	0.37	39.0	2.8	1.4		2.0	0.825	360
K21R 280 S16	K20R 250 S16	9.5	245	370	76.0	0.35	51.5	2.8	1.5		2.1	1.35	465
K21R 280 M16	K20R 250 M16	11	284	370	77.0	0.36	57.5	2.9	1.5		2.1	1.55	520
K21R 315 S16	K20R 280 S16	15	387	370	82.0	0.40	66	3.5	1.5		2.0	2.63	690
K21R 315 M16	K20R 280 M16	18.5	478	370	82.0	0.40	81.5	3.7	1.6		2.1	3.33	800
K21R 315 MX16	K20R 315 S16	22	568	370	87.5	0.46	79	3.5	1.5	1.2	1.9	3.60	880
K21R 315 MY16	K20R 315 M16	30	774	370	87.0	0.38	131	3.4	2.1	1.3	2.0	6.00	1050
K21R 315 L16	K20R 315 L16	37	955	370	84.5	0.38	166	3.2	1.2		1.7	6.76	1250
Synchronous speed 300 rpm – 20-pole version													
K21R 160 L20	K20R 160 S20	0.75	24.5	292	51.0	0.32	6.6	2.1	1.6		2.3	0.113	114
K21R 180 L20	K20R 160 M20	1.1	36.1	291	52.0	0.33	9.3	2.1	1.6		2.2	0.145	136
K21R 200 L20	K20R 180 S20	1.5	48.9	293	55.0	0.31	12.5	2.2	1.6		2.4	0.228	175
K21R 200 LX20	K20R 180 M20	1.8	58.9	292	58.0	0.32	14	2.2	1.5		2.2	0.268	200
K21R 225 M20	K20R 200 M20	2.1	68.0	295	61.0	0.28	17.5	2.3	1.5		2.6	0.440	265
K21R 250 M20	K20R 225 M20	3.0	97.1	295	63.0	0.29	23.5	2.3	1.5		2.3	0.825	360
K21R 280 S20	K20R 250 S20	4.0	129	296	62.0	0.25	37	2.2	1.6		2.2	1.35	465
K21R 280 M20	K20R 250 M20	5.5	177	296	67.0	0.27	44	2.2	1.4		2.2	1.55	520
K21R 315 S20	K20R 280 S20	7.5	241	297	79.0	0.25	55	2.4	1.4		2.4	2.63	690
K21R 315 M20	K20R 280 M20	9.5	305	297	72.0	0.25	76	2.4	1.4		2.4	3.33	800
K21R 315 MX20	K20R 315 S20	12	386	297	75.0	0.30	77	2.7	1.4		2.7	3.60	880
K21R 315 MY20	K20R 315 M20	16	516	296	80.0	0.32	90	3.0	1.4		3.0	6.00	1050
K21R 315 L20	K20R 315 L20	18	581	296	82.0	0.34	93	2.8	1.2		2.8	6.76	1250
Synchronous speed 250 rpm – 24-pole version													
K21R 160 L24	K20R 160 S24	0.37	14.7	240	40.0	0.29	4.6	1.6	1.5		2.0	0.113	114
K21R 180 L24	K20R 160 M24	0.55	21.9	240	42.0	0.28	6.8	1.6	1.5		2.0	0.145	136
K21R 200 L24	K20R 180 S24	0.75	29.2	245	44.0	0.28	8.8	1.7	1.4		2.0	0.228	175
K21R 200 LX24	K20R 180 M24	1.1	42.8	245	46.0	0.27	13	1.7	1.4		2.0	0.268	200
K21R 225 M24	K20R 200 M24	1.5	58.5	245	48.0	0.24	19	1.7	1.3		2.1	0.440	265
K21R 250 M24	K20R 225 M24	2.2	85.8	245	53.0	0.23	26	1.7	1.2		1.8	0.825	360
K21R 280 S24	K20R 250 S24	2.6	101	245	54.0	0.21	33	1.7	1.3		1.8	1.35	465
K21R 280 M24	K20R 250 M24	3	117	245	54.0	0.20	40	1.7	1.4		2.0	1.55	520
K21R 315 S24	K20R 280 S24	4	156	245	63.0	0.23	40	2.3	1.6		2.2	2.63	690
K21R 315 M24	K20R 280 M24	5.5	214	245	66.0	0.24	50	2.2	1.4		2.0	3.33	800
K21R 315 MX24	K20R 315 S24	7.5	292	245	65.0	0.23	72.5	2.2	1.4		1.9	3.60	880
K21R 315 MY24	K20R 315 M24	9.5	370	245	69.0	0.22	90.5	2.2	1.2		1.7	6.00	1050
K21R 315 L24	K20R 315 L24	11	429	245	72.0	0.24	92	2.2	1.2		1.7	6.76	1250

Three-phase motors with squirrel-cage rotor

with surface cooling, short-time duty S2, 10/30/60 min
for rated voltage, thermal class 155 (F), degree of protection IP 55, 50 Hz
Efficiency determination according to IEC/EN 60034-2

Motor selection data												Design point 400 V, 50 Hz		
Type		Short-time duty S2	P _B kW	M _B Nm	n _B rpm	η(100%) %	cosφ _B -	I _B 400 V A	I _x /I _B -	M _x /M _B -	M _s /M _B -	M _k /M _B -	J kgm ²	m kg
Synchronous speed 3000 rpm – 2-pole version														
K21R 63 K2	K2OR 56 K2	10 min	0.23	0.8	2710	63.0	0.86	0.61	3.5	1.6	1.5	1.8	0.00013	4.9
		30 min	0.22	0.8	2700	63.0	0.86	0.59	3.6	1.6	1.5	1.9		
		60 min	0.18	0.6	2790	67.1	0.76	0.51	4.1	1.9	1.9	2.2		
K21R 63 G2	K2OR 56 G2	10 min	0.35	1.3	2660	65.0	0.86	0.90	3.7	1.8	1.7	1.9	0.00015	5.2
		30 min	0.33	1.2	2680	65.0	0.85	0.86	3.8	1.9	1.8	2.0		
		60 min	0.25	0.9	2800	68.1	0.72	0.74	4.2	2.2	2.2	2.4		
K21R 71 K2	K2OR 63 K2	10 min	0.45	1.6	2690	68.0	0.88	1.08	3.9	1.5	1.5	1.7	0.00025	6.7
		30 min	0.42	1.5	2720	68.0	0.87	1.02	4.2	1.6	1.6	1.8		
		60 min	0.37	1.3	2780	71.5	0.79	0.94	4.4	2.1	2.1	2.3		
K21R 71 G2	K2OR 63 G2	10 min	0.75	2.7	2680	70.0	0.88	1.76	3.8	1.5	1.5	1.7	0.00032	7.6
		30 min	0.65	2.3	2750	72.0	0.84	1.55	4.3	1.7	1.7	2.0		
		60 min	0.55	1.9	2775	74.3	0.81	1.32	5.1	2.3	2.1	2.6		
K21R 80 K2	K2OR 71 K2	10 min	1.00	3.6	2680	70.0	0.90	2.30	4.3	2.0	1.8	2.0	0.00057	10.7
		30 min	0.90	3.1	2760	72.0	0.87	2.1	4.8	2.2	2.0	2.3		
		60 min	0.75	2.5	2825	77.5	0.81	1.72	5.9	2.4	2.4	2.4		
K21R 80 G2	K2OR 71 G2	10 min	1.5	5.3	2715	73.0	0.88	3.37	4.4	1.6	1.6	1.8	0.00072	11.5
		30 min	1.35	4.7	2760	74.0	0.86	3.05	4.9	1.8	1.8	2.0		
		60 min	1.1	3.7	2835	77.8	0.80	2.55	6.0	2.4	2.3	2.6		
K21R 90 S2	K2OR 80 K2	10 min	2.1	7.2	2800	78.0	0.88	4.42	5.3	1.8	1.6	1.8	0.00132	16.0
		30 min	1.8	6.1	2820	78.0	0.85	3.92	6.0	2.1	1.9	2.1		
		60 min	1.5	5.0	2840	81.2	0.86	3.1	7.0	2.5	2.5	2.8		
K21R 90 L2	K2OR 80 G2	10 min	3	10.4	2760	78.0	0.90	6.20	5.3	2.0	1.8	2.1	0.0017	19.0
		30 min	2.7	9.2	2790	79.0	0.89	5.55	5.9	2.3	2.1	2.4		
		60 min	2.2	7.4	2850	82.0	0.85	4.55	7.5	2.8	2.3	2.9		
K21R 100 L2	K2OR 90 L2	10 min	4.0	13.6	2810	81.5	0.89	8.00	5.4	1.5	1.5	2.0	0.00275	25.0
		30 min	3.6	12.2	2820	81.0	0.88	7.3	5.9	1.6	1.6	2.2		
		60 min	3.0	10.0	2865	83.4	0.84	6.15	6.8	2.4	2.2	2.8		
K21R 112 M2	K2OR 100 S2	10 min	5.5	18.4	2850	83.0	0.86	11.10	5.4	1.5	1.5	2.0	0.0045	32
		30 min	4.8	16.0	2870	83.0	0.85	9.8	6.1	1.5	1.5	2.2		
		60 min	4.0	13.2	2900	85.0	0.81	8.4	7.0	2.2	2.1	2.9		
K21R 132 S 2 T	K2OR 100 L2	10 min	7.2	24.2	2840	84.0	0.88	14.10	5.6	1.6	1.4	2.1	0.0055	38
		30 min	6.5	21.7	2860	84.0	0.87	12.8	6.2	1.8	1.5	2.3		
		60 min	5.5	18.2	2890	86.3	0.84	11	7.5	2.4	2.2	3.0		
K21R 132 S2	K2OR 112MY2	10 min	6.9	23	2868	81.5	0.85	14.5	4.6	1.5	1.3	2.2	0.0081	50
		30 min	6.7	22	2880	81.5	0.85	14	4.8	1.6	1.4	2.3		
		60 min	6.5	22	2883	82.0	0.85	13.5	0.4	1.6	1.4	2.4		
K21R 132 SX2	K2OR 112 M2	10 min	11.5	37	2957	80.5	0.90	23	4.1	1.1	1.1	1.8	0.0110	57
		30 min	10.0	34	2842	82.5	0.89	19.5	4.8	1.3	1.2	2.0		
		60 min	8.8	29	2850	82.5	0.88	17.5	0.5	1.4	1.4	2.3		
K21R 160 L2	K2OR 160 M2	10 min	27.5	91	2880	87.0	0.90	50.5	4.5	1.5	1.1	1.8	0.0675	134
		30 min	24.5	81	2895	88.0	0.91	44	5.2	1.6	1.3	2.0		
		60 min	21.5	71	2910	88.0	0.92	38.5	5.9	1.9	1.5	2.3		
K21R 180 M2	K2OR 180 S2	10 min	30.0	98	2910	87.0	0.90	55.5	4.1	1.3	1.0	1.8	0.105	165
		30 min	29.0	95	2916	88.0	0.90	53	4.2	1.4	1.1	1.9		
		60 min	25.5	83	2928	90.0	0.90	45.5	4.9	1.5	1.2	2.2		
K21R 200 L2	K2OR 180 M2	10 min	43.0	142	2892	91.0	0.92	74	4.5	1.3	1.0	1.8	0.128	195
		30 min	40.0	132	2901	91.0	0.92	69	4.9	1.4	1.1	1.9		
		60 min	35.0	115	2916	91.0	0.92	60.5	5.5	1.6	1.3	2.2		
K21R 200 LX2	K2OR 200 M2	10 min	49.0	160	2916	92.0	0.90	85.5	4.9	1.3	1.0	1.8	0.193	255
		30 min	49.0	160	2922	92.0	0.90	85.5	4.9	1.4	1.0	1.8		
		60 min	43.5	142	2934	92.0	0.90	76	5.5	1.5	1.1	2.0		
K21R 225 M2	K2OR 200 L2	10 min	65.0	213	2910	92.0	0.90	113	4.8	1.4	1.0	1.8	0.220	290
		30 min	60.0	196	2925	92.0	0.90	105	5.2	1.5	1.1	1.9		
		60 min	52.5	171	2940	92.0	0.90	91.5	5.9	1.7	1.3	2.2		
K21R 250 M2	K2OR 225 M2	10 min	76.0	247	2934	91.0	0.87	139	4.7	1.7	1.2	1.8	0.375	360
		30 min	73.0	237	2936	91.0	0.88	132	4.9	1.7	1.3	1.9		
		60 min	64.5	209	2943	92.0	0.90	112	5.8	2.0	1.4	2.1		

Three-phase motors with squirrel-cage rotor

with surface cooling, short-time duty S2, 10/30/60 min
for rated voltage, thermal class 155 (F), degree of protection IP 55, 50 Hz
Efficiency determination according to IEC/EN 60034-2

Motor selection data													Design point 400 V, 50 Hz	
Type	Short-time duty	P_B	M_B	n_B	$\eta(100\%)$	$\cos\phi_B$	I_B	I_A/I_B	M_A/M_B	M_S/M_B	M_K/M_B	J	m	
	S2						400 V							
		kW	Nm	rpm	%	-	A	-	-	-	-	kgm ²	kg	
Synchronous speed 3000 rpm – 2-pole version														
K21R 280 S2	K20R 250 S2	10 min	95.0	316	2868	93.0	0.90	164	4.9	1.3	1.1	1.8	0.650	490
		30 min	95.0	316	2874	93.0	0.91	162	5.0	1.3	1.1	1.8		
		60 min	88.0	292	2880	93.0	0.91	150	5.4	1.4	1.2	1.9		
K21R 280 M2	K20R 250 M2	10 min	130	420	2957	94.0	0.92	217	4.8	1.2	1.0	1.8	0.675	510
		30 min	120	387	2961	94.0	0.92	200	5.3	1.3	1.1	1.9		
		60 min	105	338	2967	94.0	0.91	177	5.9	1.5	1.3	2.2		
K21R 315 S2	K20R 280 S2	10 min	150	484	2958	93.5	0.90	257	5.0	1.3	1.2	1.8	1.21	720
		30 min	145	468	2961	94.0	0.90	247	5.2	1.4	1.3	1.9		
		60 min	125	402	2967	94.0	0.90	213	6.0	1.6	1.5	2.2		
K21R 315 M2	K20R 280 M2	10 min	175	565	2958	94.5	0.89	300	5.1	1.3	1.1	1.8	1.44	800
		30 min	175	564	2961	94.5	0.89	300	5.1	1.3	1.1	1.8		
		60 min	150	483	2967	94.5	0.90	255	6.0	1.5	1.3	2.1		
K21R 315 MX2	K20R 315 S2	10 min	220	710	2958	95.0	0.90	371	4.9	1.4	1.3	1.8	1.76	980
		30 min	210	677	2961	95.0	0.90	355	5.1	1.5	1.4	1.9		
		60 min	185	595	2967	95.0	0.90	312	5.8	1.7	1.6	2.2		
K21R 315 MY2	K20R 315 M2	10 min	300	973	2946	95.0	0.91	501	4.6	1.7	1.5	1.8	2.82	1170
		30 min	265	857	2952	95.0	0.92	438	5.2	2.0	1.7	2.0		
		60 min	230	743	2958	95.0	0.92	380	6.0	2.3	1.9	2.3		
K21R 315 L2	K20R 315 L2	10 min	315	1021	2946	95.5	0.91	523	5.7	1.7	1.1	1.6	3.66	1460
		30 min	330	1068	2952	95.5	0.92	542	5.5	1.6	1.1	1.5		
		60 min	290	936	2958	95.5	0.92	476	6.3	1.8	1.2	1.7		
K21R 315 LX2	K20R 315 LX2	10 min	400	1294	2952	95.5	0.92	657	5.8	1.9	1.1	1.6	4.43	1630
		30 min	400	1294	2952	95.5	0.92	657	5.8	1.9	1.1	1.6		
		60 min	350	1130	2958	95.5	0.92	575	6.6	2.1	1.3	1.8		

Three-phase motors with squirrel-cage rotor

with surface cooling, short-time duty S2, 10/30/60 min
for rated voltage, thermal class 155 (F), degree of protection IP 55, 50 Hz
Efficiency determination according to IEC/EN 60034-2

Motor selection data													Design point 400 V, 50 Hz	
Type		Short-time duty S2	P_B kW	M_B Nm	n_b rpm	$\eta(100\%)$ %	$\cos\phi_B$ -	I_b 400 V A	I_x/I_b -	M_x/M_B -	M_g/M_B -	M_k/M_B -	J kgm ²	m kg
Synchronous speed 1500 rpm – 4-pole version														
K21R 63 K4	K20R 56 K4	10 min	0.15	1.1	1325	56.0	0.78	0.50	2.8	1.4	1.4	1.7	0.00019	4.8
		30 min	0.14	1.0	1340	57.5	0.75	0.47	2.9	1.5	1.5	1.9		
		60 min	0.12	0.8	1370	57.5	0.68	0.44	3.2	1.9	1.8	2.2		
K21R 63 G4	K20R 56 G4	10 min	0.23	1.7	1290	59.0	0.78	0.72	2.9	1.6	1.6	1.7	0.00024	5.2
		30 min	0.22	1.6	1295	58.0	0.77	0.71	2.9	1.7	1.7	1.8		
		60 min	0.18	1.3	1360	61.0	0.66	0.65	3.3	2.0	2.0	2.3		
K21R 71 K4	K20R 63 K4	10 min	0.30	2.1	1340	61.0	0.80	0.89	3.0	1.4	1.4	1.6	0.00040	6.8
		30 min	0.28	2.0	1350	62.0	0.78	0.84	3.2	1.5	1.5	1.7		
		60 min	0.25	1.7	1385	64.6	0.72	0.78	3.6	1.8	1.8	2.1		
K21R 71 G4	K20R 63 G4	10 min	0.45	3.2	1325	64.0	0.81	1.25	3.3	1.5	1.5	1.7	0.00050	7.8
		30 min	0.40	2.8	1350	66.0	0.77	1.14	3.6	1.6	1.6	1.9		
		60 min	0.37	2.6	1370	67.8	0.74	1.06	3.8	2.0	2.0	2.2		
K21R 80 K4	K20R 71 K4	10 min	0.75	5.3	1350	67.0	0.82	1.97	3.3	1.4	1.4	1.7	0.00087	10.6
		30 min	0.70	4.9	1360	68.0	0.80	1.86	3.5	1.5	1.5	1.8		
		60 min	0.55	3.8	1400	71.5	0.69	1.60	4.1	2.1	2.0	2.3		
K21R 80 G4	K20R 71 G4	10 min	1.00	7.0	1360	70.0	0.80	2.58	3.9	1.7	1.7	1.9	0.00107	11.7
		30 min	0.90	6.3	1375	71.0	0.77	2.38	4.2	1.9	1.9	2.1		
		60 min	0.75	5.1	1400	73.5	0.70	2.10	4.6	2.2	2.1	2.3		
K21R 90 S4	K20R 80 K4	10 min	1.5	10.6	1350	70.0	0.89	3.45	4.0	1.3	1.3	1.6	0.00207	15.5
		30 min	1.4	9.8	1360	70.0	0.87	3.32	4.1	1.4	1.4	1.7		
		60 min	1.1	7.5	1410	76.6	0.79	2.62	5.5	2.3	2.2	2.5		
K21R 90 L4	K20R 80 G4	10 min	2	14.2	1345	72.0	0.89	4.50	4.2	1.4	1.4	1.7	0.00260	18.0
		30 min	1.8	12.6	1365	74.0	0.87	4.05	4.6	1.5	1.5	1.9		
		60 min	1.5	10.2	1400	78.8	0.81	3.40	5.5	2.5	2.4	2.6		
K21R 100 L4	K20R 90 L4	10 min	3	20.6	1390	78.0	0.84	6.70	4.8	1.9	1.5	2.0	0.00400	23.5
		30 min	2.8	19.2	1395	78.0	0.83	6.25	5.1	2.0	1.6	2.2		
		60 min	2.2	14.9	1410	81.2	0.79	4.95	6.0	2.5	2.3	2.7		
K21R 100 LX4	K20R 100 S4	10 min	4.0	27.2	1405	79.5	0.84	8.65	5.0	1.5	1.5	1.9	0.00725	30
		30 min	3.8	25.7	1415	79.5	0.84	8.20	5.3	1.6	1.6	2.0		
		60 min	3.0	20.0	1430	82.6	0.79	6.65	6.5	2.5	2.2	2.9		
K21R 112 M4	K20R 100 L4	10 min	5.5	38	1390	81.0	0.84	11.70	5.3	1.6	1.6	2.2	0.00900	37
		30 min	5.0	34	1400	80.0	0.84	10.7	5.8	1.8	1.8	2.4		
		60 min	4.0	27	1435	85.0	0.78	8.80	6.9	2.6	2.5	3.2		
K21R 132 S4	K20R 112 M4	10 min	8.5	58	1397	81.0	0.89	17	4.0	1.2	1.1	1.9	0.01500	50
		30 min	7.3	49	1413	81.5	0.90	14.5	4.7	1.4	1.3	2.2		
		60 min	6.5	44	1425	82.0	0.89	13	5.3	1.6	1.4	2.5		
K21R 132 M4	K20R 132 S4	10 min	12.0	81	1418	82.5	0.88	24	3.8	1.2	1.0	1.8	0.0280	70
		30 min	10.0	67	1436	84.0	0.87	20	4.5	1.5	1.3	2.2		
		60 min	8.8	58	1443	85.0	0.85	17.5	5.1	1.7	1.4	2.5		
K21R 160 M4	K20R 132 M4	10 min	16.0	107	1425	84.0	0.88	31	4.7	1.5	1.3	2.2	0.0350	92
		30 min	14.5	97	1434	85.0	0.88	28	5.2	1.7	1.4	2.5		
		60 min	12.5	83	1445	85.5	0.86	24.5	6.0	1.9	1.7	2.9		
K21R 160 L4	K20R 160 S4	10 min	22.0	147	1428	86.0	0.86	43	4.8	1.7	1.3	2.0	0.0780	120
		30 min	20.5	135	1449	87.0	0.87	39	5.3	1.8	1.4	2.2		
		60 min	17.5	115	1458	88.0	0.86	33.5	6.2	2.1	1.7	2.6		
K21R 180 M4	K20R 160 M4	10 min	29.0	194	1425	87.0	0.86	56	4.3	1.6	1.2	1.8	0.0900	136
		30 min	25.5	168	1448	87.5	0.87	48.5	4.9	1.8	1.4	2.1		
		60 min	21.5	141	1457	88.0	0.86	41	5.8	2.1	1.7	2.5		
K21R 180 L4	K20R 180 S4	10 min	34.0	225	1445	89.0	0.83	66.5	4.1	1.3	1.1	1.7	0.1380	170
		30 min	31.5	207	1452	89.0	0.84	61	4.5	1.4	1.2	1.8		
		60 min	26.0	170	1458	90.0	0.84	49.5	5.5	1.7	1.5	2.2		
K21R 200 L4	K20R 180 M4	10 min	45.0	297	1446	90.0	0.84	86	3.9	1.3	1.1	1.6	0.1680	200
		30 min	40.0	263	1452	90.0	0.86	74.5	4.5	1.5	1.3	1.9		
		60 min	35.0	229	1458	90.0	0.87	64.5	5.2	1.7	1.5	2.1		
K21R 225 S4	K20R 200 M4	10 min	55.0	361	1454	92.0	0.85	102	4.3	1.3	1.1	1.7	0.2750	270
		30 min	51.0	334	1460	92.0	0.85	94	4.6	1.4	1.2	1.8		
		60 min	45.0	294	1463	92.0	0.85	83	5.2	1.6	1.4	2.0		
K21R 225 M4	K20R 200 L4	10 min	65.0	429	1448	93.0	0.83	122	4.3	1.5	1.2	1.7	0.3130	300
		30 min	62.5	411	1452	93.0	0.83	117	4.5	1.6	1.2	1.8		
		60 min	55.0	360	1460	92.0	0.85	102	5.2	1.8	1.4	2.0		

Three-phase motors with squirrel-cage rotor

with surface cooling, short-time duty S2, 10/30/60 min
for rated voltage, thermal class 155 (F), degree of protection IP 55, 50 Hz
Efficiency determination according to IEC/EN 60034-2

Motor selection data													Design point 400 V, 50 Hz	
Type	Short-time duty S2	P_B kW	M_B Nm	n_B rpm	$\eta(100\%)$ %	$\cos\phi_B$ -	I_B 400 V A	I_A/I_B -	M_A/M_B -	M_S/M_B -	M_K/M_B -	J kgm ²	m kg	
Synchronous speed 1500 rpm – 4-pole version														
K21R 250 M4	K20R 225 M4	10 min	75.0	489	1464	92.0	0.85	138	5.0	1.7	1.3	1.7	0.5250	375
		30 min	70.0	456	1467	92.0	0.85	129	5.3	1.9	1.4	1.8		
		60 min	65.0	422	1470	92.0	0.85	120	5.7	2.0	1.5	1.9		
K21R 280 S4	K20R 250 S4	10 min	95.0	618	1467	92.0	0.84	177	5.3	1.6	1.3	1.7	0.9500	520
		30 min	91.0	592	1469	92.0	0.84	170	5.5	1.6	1.4	1.8		
		60 min	85.0	551	1473	93.0	0.85	155	6.1	1.8	1.5	1.9		
K21R 280 M4	K20R 250 M4	10 min	115	745	1474	94.0	0.84	210	5.3	1.6	1.2	1.7	1.10	580
		30 min	110	712	1475	94.2	0.84	201	5.6	1.7	1.3	1.8		
		60 min	105	679	1476	94.0	0.85	190	5.9	1.8	1.4	1.9		
K21R 315 S4	K20R 280 S4	10 min	155	1002	1478	93.5	0.85	282	4.8	1.5	1.3	1.7	1.96	740
		30 min	145	936	1479	94.0	0.85	262	5.2	1.6	1.4	1.8		
		60 min	130	838	1482	94.0	0.85	235	5.8	1.8	1.6	2.0		
K21R 315 M4	K20R 280 M4	10 min	185	1199	1473	94.0	0.85	334	4.8	1.5	1.3	1.7	2.27	840
		30 min	175	1134	1474	94.0	0.85	316	5.1	1.6	1.4	1.8		
		60 min	155	1001	1479	94.0	0.85	280	5.8	1.8	1.5	2.0		
K21R 315 MX4	K20R 315 S4	10 min	205	1329	1473	94.0	0.85	370	4.9	1.4	1.3	1.7	2.73	1000
		30 min	195	1263	1475	94.0	0.86	348	5.2	1.5	1.4	1.8		
		60 min	185	1197	1476	94.0	0.86	330	5.5	1.6	1.5	1.9		
K21R 315 MY4	K20R 315 M4	10 min	275	1781	1475	95.0	0.87	480	4.9	1.4	1.3	1.7	4.82	1200
		30 min	265	1715	1476	95.0	0.87	463	5.0	1.5	1.4	1.8		
		60 min	235	1517	1479	95.0	0.88	406	5.7	1.7	1.5	2.0		
K21R 315 L4	K20R 315 L4	10 min	315	2039	1475	95.5	0.88	541	6.2	1.6	1.3	1.8	5.93	1450
		30 min	305	1973	1476	95.5	0.88	524	6.4	1.6	1.3	1.9		
		60 min	290	1873	1479	95.5	0.88	498	6.8	1.7	1.4	2.0		
K21R 315 LX4	K20R 315 LX4	10 min	390	2510	1484	96.0	0.86	682	6.7	1.5	1.2	2.0	6.82	1630
		30 min	375	2412	1485	96.0	0.87	648	7.1	1.6	1.3	2.1		
		60 min	360	2310	1488	96.0	0.87	622	7.4	1.7	1.3	2.2		

Three-phase motors with squirrel-cage rotor

with surface cooling, short-time duty S2, 10/30/60 min
for rated voltage, thermal class 155 (F), degree of protection IP 55, 50 Hz
Efficiency determination according to IEC/EN 60034-2

Motor selection data													Design point 400 V, 50 Hz	
Type		Short-time duty S2	P _B kW	M _B Nm	n _B rpm	η(100%) %	cosφ _B -	I _B 400 V A	I _x /I _B -	M _x /M _B -	M _y /M _B -	M _k /M _B -	J kgm ²	m kg
Synchronous speed 1000 rpm – 6-pole version														
K21R 63 K6	K20R 56 K6	10 min	0.12	1.4	835	50.0	0.65	0.54	2.1	1.5	1.5	1.6	0.00024	4.9
		30 min	0.11	1.2	850	48.0	0.64	0.52	2.2	1.7	1.7	1.8		
		60 min	0.09	1.0	895	50.5	0.56	0.46	2.5	2.0	2.0	2.4		
K21R 63 G6	K20R 56 G6	10 min	0.15	1.7	845	50.0	0.64	0.68	2.2	1.4	1.4	1.6	0.00027	5.7
		30 min	0.14	1.6	855	50.0	0.62	0.65	2.3	1.5	1.5	1.8		
		60 min	0.12	1.3	880	52.0	0.56	0.59	2.5	2.0	2.0	2.3		
K21R 71 K6	K20R 63 K6	10 min	0.25	2.7	875	56.0	0.65	0.99	2.5	1.5	1.5	1.6	0.00045	7.4
		30 min	0.23	2.5	890	57.0	0.62	0.94	2.6	1.6	1.6	1.8		
		60 min	0.18	1.9	925	58.0	0.51	0.88	2.8	1.6	1.6	2.1		
K21R 71 G6	K20R 63 G6	10 min	0.30	3.3	875	59.0	0.60	1.23	2.6	1.6	1.6	1.8	0.00060	8.3
		30 min	0.28	3.0	880	58.0	0.59	1.18	2.8	1.7	1.7	1.9		
		60 min	0.25	2.6	915	60.0	0.55	1.10	2.9	2.0	2.0	2.2		
K21R 80 K6	K20R 71 K6	10 min	0.45	4.8	900	64.0	0.76	1.34	3.1	1.3	1.3	1.6	0.00130	11.0
		30 min	0.42	4.4	905	64.0	0.74	1.28	3.3	1.4	1.4	1.7		
		60 min	0.37	3.9	915	66.0	0.66	1.22	3.4	2.0	2.0	2.0		
K21R 80 G6	K20R 71 G6	10 min	0.65	6.9	900	65.0	0.75	1.93	3.2	1.5	1.5	1.8	0.00175	12.5
		30 min	0.60	6.3	905	65.0	0.72	1.85	3.4	1.6	1.6	2.0		
		60 min	0.55	5.7	915	68.0	0.67	1.73	3.7	2.2	2.2	2.4		
K21R 90 S6	K20R 80 K6	10 min	1.00	10.4	915	67.5	0.72	2.97	3.5	1.4	1.4	1.9	0.00325	16.0
		30 min	0.90	9.3	925	68.0	0.69	2.75	3.8	1.6	1.6	2.1		
		60 min	0.75	7.7	935	70.0	0.64	2.43	4.5	2.4	2.4	2.6		
K21R 90 L6	K20R 80 G6	10 min	1.5	15.9	900	69.0	0.76	4.15	3.4	1.5	1.5	1.7	0.00425	19.0
		30 min	1.4	14.8	905	68.0	0.75	3.95	3.6	1.6	1.6	1.8		
		60 min	1.1	11.2	935	73.0	0.69	3.15	4.6	2.2	2.2	2.6		
K21R 100 L6	K20R 90 L6	10 min	2	20.9	915	72.0	0.77	5.20	3.6	1.3	1.3	1.6	0.00625	24.0
		30 min	1.8	18.6	925	74.0	0.74	4.75	3.9	1.5	1.5	1.8		
		60 min	1.5	15.2	945	76.4	0.73	3.90	4.6	2.1	2.0	2.4		
K21R 112 M6	K20R 100 L6	10 min	3	31.1	920	76.0	0.84	6.80	4.2	1.5	1.5	1.9	0.01225	33.5
		30 min	2.8	28.9	925	77.0	0.83	6.35	4.5	1.6	1.6	2.0		
		60 min	2.2	22.1	950	79.8	0.74	5.35	5.3	2.2	2.1	2.7		
K21R 132 S6	K20R 112 M6	10 min	5.0	53	908	71.0	0.87	11.5	3.3	1.1	1.0	1.6	0.0180	46
		30 min	4.6	48	915	73.0	0.86	10.5	3.6	1.3	1.1	1.8		
		60 min	3.5	35	943	78.0	0.82	8	4.7	1.7	1.5	2.4		
K21R 132 M6	K20R 112 MX6	10 min	7.0	73	912	72.0	0.86	16.5	3.3	1.3	1.1	1.6	0.0230	53
		30 min	6.2	65	916	76.0	0.86	13.5	4.0	1.4	1.2	1.9		
		60 min	4.7	48	941	79.0	0.82	10.5	5.1	1.9	1.7	2.5		
K21R 132 MX6	K20R 132 S6	10 min	8.0	82	930	77.0	0.85	17.5	3.3	1.3	1.1	1.6	0.0430	70
		30 min	7.3	74	938	79.0	0.85	15.5	3.7	1.4	1.3	1.8		
		60 min	6.5	66	947	81.0	0.84	13.5	4.3	1.6	1.4	2.0		
K21R 160 M6	K20R 132 M6	10 min	12.0	123	932	77.0	0.84	27	3.2	1.2	1.0	1.5	0.0530	86
		30 min	10.5	106	944	81.0	0.84	22.5	3.8	1.4	1.1	1.8		
		60 min	8.8	88	953	82.0	0.84	18.5	4.6	1.7	1.4	2.1		
K21R 160 L6	K20R 160 S6	10 min	16.0	163	939	85.0	0.88	31	3.5	1.3	1.1	1.5	0.1130	114
		30 min	14.0	141	949	85.0	0.87	27.5	4.0	1.5	1.3	1.8		
		60 min	12.5	125	955	85.0	0.87	24.5	4.5	1.7	1.5	2.0		
K21R 180 L6	K20R 160 M6	10 min	24.0	244	940	85.0	0.83	49	3.4	1.5	1.3	1.6	0.1450	136
		30 min	22.5	227	945	85.0	0.83	46	3.6	1.6	1.4	1.8		
		60 min	17.5	174	960	85.0	0.82	36	4.7	2.0	1.9	2.3		
K21R 200 L6	K20R 180 S6	10 min	26.0	263	944	86.0	0.88	49.5	3.9	1.4	1.2	1.7	0.2280	175
		30 min	24.5	246	952	86.0	0.88	46.5	4.2	1.5	1.3	1.8		
		60 min	21.0	209	960	87.0	0.87	40	4.9	1.8	1.5	2.1		
K21R 200 LX6	K20R 180 M6	10 min	35.0	354	943	87.0	0.86	67.5	3.6	1.3	1.1	1.6	0.2680	200
		30 min	33.0	333	947	87.0	0.86	63.5	3.9	1.4	1.2	1.8		
		60 min	25.0	248	962	88.0	0.86	47.5	5.2	1.8	1.6	2.4		
K21R 225 M6	K20R 200 M6	10 min	45.0	452	950	89.0	0.88	83	4.0	1.4	1.1	1.6	0.4430	265
		30 min	41.5	415	955	89.0	0.88	76.5	4.3	1.6	1.2	1.8		
		60 min	35.0	347	964	89.0	0.88	64.5	5.1	1.9	1.4	2.1		
K21R 250 M6	K20R 225 M6	10 min	50.0	497	960	88.0	0.86	95.5	4.1	1.5	1.1	1.7	0.8250	360
		30 min	47.0	466	963	89.0	0.87	87.5	4.5	1.6	1.2	1.8		
		60 min	43.5	430	966	90.0	0.89	78.5	5.0	1.7	1.3	1.9		

Three-phase motors with squirrel-cage rotor

with surface cooling, short-time duty S2, 10/30/60 min
for rated voltage, thermal class 155 (F), degree of protection IP 55, 50 Hz
Efficiency determination according to IEC/EN 60034-2

Motor selection data													Design point 400 V, 50 Hz	
Type	Short-time duty S2	P_B kW	M_B Nm	n_B rpm	$\eta(100\%)$ %	$\cos\phi_B$ -	I_B 400 V A	I_A/I_B -	M_A/M_B -	M_S/M_B -	M_K/M_B -	J kgm ²	m kg	
Synchronous speed 1000 rpm – 6-pole version														
K21R 280 S6	K20R 250 S6	10 min	55.0	539	975	90.0	0.86	103	4.7	1.6	1.2	1.6	1.28	465
		30 min	55.0	539	975	90.0	0.86	103	4.7	1.6	1.2	1.6		
		60 min	52.0	508	978	91.0	0.86	96	5.1	1.7	1.3	1.7		
K21R 280 M6	K20R 250 M6	10 min	72.0	705	975	90.0	0.85	136	4.3	1.6	1.2	1.7	1.48	520
		30 min	67.0	654	978	92.0	0.87	121	4.8	1.7	1.3	1.8		
		60 min	64.0	624	979	92.0	0.87	115	5.1	1.8	1.4	1.9		
K21R 315 S6	K20R 280 S6	10 min	110	1072	980	92.5	0.86	200	4.3	1.4	1.2	1.6	2.63	690
		30 min	100	973	982	93.0	0.86	180	4.8	1.5	1.3	1.8		
		60 min	88	853	985	93.0	0.87	157	5.5	1.7	1.4	2.0		
K21R 315 M6	K20R 280 M6	10 min	130	1267	980	93.0	0.86	235	4.3	1.4	1.2	1.6	3.33	800
		30 min	120	1166	983	93.0	0.86	217	4.7	1.5	1.3	1.8		
		60 min	105	1018	985	94.0	0.87	185	5.5	1.7	1.4	2.0		
K21R 315 MX6	K20R 315 S6	10 min	165	1611	978	93.0	0.86	298	4.5	1.5	1.3	1.7	3.60	880
		30 min	155	1510	980	93.0	0.86	280	4.8	1.6	1.3	1.8		
		60 min	125	1214	983	93.8	0.87	221	6.1	2.0	1.7	2.3		
K21R 315 MY6	K20R 315 M6	10 min	200	1953	978	94.5	0.88	347	4.6	1.6	1.3	1.7	6.00	1050
		30 min	190	1852	980	94.5	0.88	330	4.8	1.7	1.4	1.8		
		60 min	155	1503	985	94.5	0.88	269	5.9	2.0	1.7	2.2		
K21R 315 L6	K20R 315 L6	10 min	220	2148	978	94.5	0.88	382	5.4	1.7	1.4	1.7	6.67	1250
		30 min	210	2046	980	94.5	0.88	364	5.7	1.7	1.4	1.8		
		60 min	185	1794	985	94.5	0.88	321	6.4	2.0	1.6	2.1		
K21R 315 LX6	K20R 315 LX6	10 min	270	2637	978	94.0	0.85	488	5.9	1.6	1.5	2.0	8.6	1460
		30 min	250	2431	982	94.5	0.86	444	6.5	1.7	1.6	2.1		
		60 min	235	2269	989	95.0	0.86	415	7.0	1.9	1.7	2.3		

Three-phase motors with squirrel-cage rotor

with surface cooling, short-time duty S2, 10/30/60 min
for rated voltage, thermal class 155 (F), degree of protection IP 55, 50 Hz
Efficiency determination according to IEC/EN 60034-2

Motor selection data													Design point 400 V, 50 Hz		
Type		Short-time duty S2	P _B kW	M _B Nm	n _B rpm	η(100%) %	cosφ _B -	I _B 400 V A	I _x /I _B -	M _x /M _B -	M _g /M _B -	M _K /M _B -	J kgm ²	m kg	
Synchronous speed 750 rpm – 8-pole version															
K21R 71 K8	K20R 63 K8	10 min	0.105	1.5	655	45.0	0.58	0.58	2.0	1.5	1.5	1.8	0.00050	6.6	
		30 min	0.10	1.4	665	44.0	0.58	0.57	2.1	1.6	1.6	1.8			
		60 min	0.09	1.3	675	45.5	0.51	0.56	2.1	1.9	1.9	2.1			
K21R 71 G8	K20R 63 G8	10 min	0.14	2.0	655	47.0	0.57	0.75	2.1	1.4	1.4	1.8	0.00060	8.1	
		30 min	0.13	1.9	665	46.0	0.56	0.74	2.1	1.5	1.5	1.9			
		60 min	0.12	1.7	670	46.5	0.51	0.73	2.3	1.8	1.8	2.1			
K21R 80 K8	K20R 71 K8	10 min	0.22	3.1	670	56.0	0.68	0.83	2.4	1.3	1.3	1.6	0.00130	10.5	
		30 min	0.21	3.0	675	56.0	0.67	0.81	2.5	1.4	1.4	1.7			
		60 min	0.18	2.5	690	56.5	0.59	0.78	2.8	2.0	2.0	2.2			
K21R 80 G8	K20R 71 G8	10 min	0.35	5.1	655	57.0	0.68	1.30	2.6	1.4	1.4	1.5	0.00175	12.0	
		30 min	0.33	4.8	660	56.0	0.68	1.24	2.7	1.5	1.5	1.7			
		60 min	0.25	3.4	695	58.0	0.56	1.12	3.0	2.3	2.3	2.5			
K21R 90 S8	K20R 80 K8	10 min	0.50	7.0	680	59.0	0.65	1.87	2.6	1.3	1.3	1.6	0.00300	15.0	
		30 min	0.45	6.2	690	60.0	0.62	1.75	2.8	1.4	1.4	1.8			
		60 min	0.37	5.1	700	61.5	0.54	1.6	3.0	1.9	1.9	2.1			
K21R 90 L8	K20R 80 G8	10 min	0.70	9.8	680	64.0	0.64	2.48	2.8	1.4	1.4	1.7	0.00375	18.0	
		30 min	0.65	9.1	685	64.0	0.62	2.37	2.9	1.5	1.5	1.8			
		60 min	0.55	7.6	695	64.5	0.60	2.04	3.2	1.9	1.9	2.2			
K21R 100 L8	K20R 90 L8	10 min	0.95	13.2	690	64.0	0.65	3.30	2.8	1.3	1.3	1.6	0.00625	23.0	
		30 min	0.90	12.4	695	64.0	0.64	3.15	2.9	1.4	1.4	1.7			
		60 min	0.75	10.2	705	67.0	0.60	2.7	3.3	2.0	2.0	2.3			
K21R 100 LX8	K20R 100 S8	10 min	1.5	21.1	680	70.0	0.76	4.05	3.2	1.4	1.4	1.6	0.00900	28.0	
		30 min	1.4	19.5	685	71.0	0.74	3.85	3.4	1.5	1.5	1.8			
		60 min	1.1	14.9	705	73.0	0.67	3.25	4.0	2.0	2.0	2.4			
K21R 112 M8	K20R 100 L8	10 min	2	27.9	685	72.0	0.77	5.20	3.3	1.5	1.5	1.7	0.01225	33.5	
		30 min	1.8	24.9	690	74.0	0.75	4.68	3.7	1.7	1.7	1.9			
		60 min	1.5	20.3	705	75.5	0.70	4.1	4.4	2.2	2.1	2.5			
K21R 132 S8	K20R 112 M8	10 min	2.8	39	694	72.6	0.79	7		1.3	1.2	1.8	0.01800	46	
		30 min	2.8	39	694	72.6	0.79	7		1.3	1.2	1.8			
		60 min	2.6	36	699	73.5	0.77	6.6							
K21R 132 M8	K20R 112 MX8	10 min	3.8	53	686	73.6	0.80	9.3	3.2	1.3	1.2	1.8	0.0230	53	
		30 min	3.8	53	686	73.6	0.80	9.3	3.2	1.3	1.2	1.8			
		60 min	3.5	48	692	75.0	0.77	8.7	3.4	1.4	1.4	1.9			
K21R 160 M8	K20R 132 S8	10 min	4.2	57	704	77.0	0.78	10	3.8	1.5	1.3	1.8	0.0430	70	
		30 min	4.2	57	704	77.0	0.78	10	3.8	1.5	1.3	1.8			
		60 min	4.2	57	704	77.0	0.78	10	3.8	1.5	1.3	1.8			
K21R 160 MX8	K20R 132 M8	10 min	6.4	86	707	79.0	0.78	15	3.5	1.5	1.4	1.8	0.0530	86	
		30 min	6.4	86	707	79.0	0.78	15	3.5	1.5	1.4	1.8			
		60 min	6.4	86	707	79.0	0.78	15	3.5	1.5	1.4	1.8			
K21R 160 L8	K20R 160 S8	10 min	8.8	117	720	81.0	0.78	20	3.7	1.5	1.4	1.8	0.1130	114	
		30 min	8.8	117	720	81.0	0.78	20	3.7	1.5	1.4	1.8			
		60 min	8.8	117	720	81.0	0.78	20	3.7	1.5	1.4	1.8			
K21R 180 L8	K20R 160 M8	10 min	12.8	171	714	84.0	0.79	28	3.9	1.7	1.4	1.8	0.1450	136	
		30 min	12.8	171	714	84.0	0.79	28	3.9	1.7	1.4	1.8			
		60 min	12.8	171	714	84.0	0.79	28	3.9	1.7	1.4	1.8			
K21R 200 L8	K20R 180 S8	10 min	19.2	257	714	84.0	0.80	41	4.0	1.5	1.3	1.8	0.228	175	
		30 min	19.2	257	714	84.0	0.80	41	4.0	1.5	1.3	1.8			
		60 min	17.6	233	720	85.0	0.78	38.5	4.2	1.7	1.4	1.9			
	K20R 180 M8	K20R 180 M8	10 min	23.5	316	711	86.0	0.82	48	4.0	1.6	1.3	1.7	0.268	200
			30 min	23.5	316	711	86.0	0.82	48	4.0	1.6	1.3	1.7		
			60 min	21.5	287	716	86.0	0.82	44	4.3	1.7	1.5	1.9		
K21R 225 S8		10 min	22.5	297	724	87.5	0.83	44.5	4.3	1.6	1.3	1.8	0.440	265	
		30 min	22.5	297	724	87.5	0.83	44.5	4.3	1.6	1.3	1.8			
		60 min	21.5	283	726	88.0	0.82	43	4.4	1.7	1.4	1.9			
K21R 225 M8	K20R 200 M8	10 min	28.0	373	716	87.5	0.84	55	4.0	1.4	1.2	1.7	0.440	265	
		30 min	28.0	373	716	87.5	0.84	55	4.0	1.4	1.2	1.7			
		60 min	25.5	338	720	88.5	0.84	49.5	4.5	1.5	1.3	1.9			
K21R 250 M8	K20R 225 M8	10 min	36.5	479	727	89.0	0.80	74	4.5	1.8	1.5	1.8	0.825	360	
		30 min	36.5	479	727	89.0	0.80	74	4.5	1.8	1.5	1.8			
		60 min	35.0	459	728	90.0	0.80	70	4.7	1.9	1.5	1.9			

Three-phase motors with squirrel-cage rotor

with surface cooling, short-time duty S2, 10/30/60 min
for rated voltage, thermal class 155 (F), degree of protection IP 55, 50 Hz
Efficiency determination according to IEC/EN 60034-2

Motor selection data													Design point 400 V, 50 Hz	
Type	Short-time duty S2	P_B kW	M_B Nm	n_B rpm	$\eta(100\%)$ %	$\cos\phi_B$ -	I_B 400 V A	I_A/I_B -	M_A/M_B -	M_S/M_B -	M_K/M_B -	J kgm ²	m kg	
Synchronous speed 750 rpm – 8-pole version														
K21R 280 S8	K20R 250 S8	10 min	45.0	588	731	90.0	0.80	90	4.5	1.6	1.2	1.6	1.35	465
		30 min	45.0	588	731	90.0	0.80	90	4.5	1.6	1.2	1.6		
		60 min	41.0	535	732	90.0	0.80	82	4.9	1.8	1.3	1.8		
K21R 280 M8	K20R 250 M8	10 min	55.0	717	733	91.0	0.79	110	4.6	1.8	1.2	1.6	1.55	520
		30 min	55.0	717	733	91.0	0.79	110	4.6	1.8	1.2	1.6		
		60 min	50.0	651	734	91.0	0.78	102	5.0	2.0	1.3	1.8		
K21R 315 S8	K20R 280 S8	10 min	73.0	946	737	92.0	0.79	145	4.4	1.5	1.2	1.8	2.63	690
		30 min	73.0	946	737	92.0	0.79	145	4.4	1.5	1.2	1.8		
		60 min	73.0	946	737	92.0	0.79	145	4.4	1.5	1.2	1.8		
K21R 315 M8	K20R 280 M8	10 min	100	1319	724	92.0	0.79	199	4.3	1.5	1.2	1.7	3.33	800
		30 min	100	1319	724	92.0	0.79	199	4.3	1.5	1.2	1.7		
		60 min	95	1250	726	92.0	0.81	184	4.7	1.5	1.2	1.8		
K21R 315 MX8	K20R 315 S8	10 min	110	1429	735	93.0	0.81	211	4.9	1.6	1.4	2.0	3.60	880
		30 min	110	1429	735	93.0	0.81	211	4.9	1.6	1.4	2.0		
		60 min	110	1429	735	93.0	0.81	211	4.9	1.6	1.4	2.0		
K21R 315 MY8	K20R 315 M8	10 min	160	2076	736	92.0	0.80	314	4.0	1.6	1.4	1.8	6.00	1050
		30 min	160	2076	736	92.0	0.80	314	4.0	1.6	1.4	1.8		
		60 min	150	1944	737	93.0	0.80	291	4.3	1.8	1.5	1.9		
K21R 315 L8	K20R 315 L8	10 min	165	2138	737	94.0	0.82	309	5.0	1.6	1.4	1.7	6.76	1250
		30 min	165	2138	737	94.0	0.82	309	5.0	1.6	1.4	1.7		
		60 min	155	2008	737	94.5	0.82	289	5.3	1.7	1.4	1.8		
K21R 315 LX8	K20R 315 LX8	10 min	210	2736	733	93.0	0.77	423	5.2	1.7	1.4	1.9	8.71	1430
		30 min	200	2602	734	94.0	0.77	399	5.5	1.7	1.5	2.0		
		60 min	180	2339	735	95.0	0.78	351	6.3	1.9	1.7	2.2		

Three-phase motors with squirrel-cage rotor

with surface cooling, intermittent periodic duty S3-25 %/40 %/60 %
 for rated voltage, thermal class 155 (F), degree of protection IP 55, 50 Hz
 Efficiency determination according to IEC/EN 60034-2

Motor selection data												Design point 400 V, 50 Hz		
Type	c.d.f. S3	P _B kW	M _B Nm	n _B rpm	η(100%) %	cosφ _B -	I _B 400 V A	I _x /I _B -	M _x /M _B -	M _s /M _B -	M _K /M _B -	J kgm ²	m kg	
Synchronous speed 3000 rpm – 2-pole version														
K210 56 K2	25 %	0.09	0.3	2865	69.0	0.75	0.25	4.9	2.3	2.3	2.8	0.00013	4.4	
	40 %	0.09	0.3	2865	69.0	0.75	0.25	4.9	2.3	2.3	2.8			
	60 %	0.09	0.3	2865	69.0	0.75	0.25	4.9	2.3	2.3	2.8			
K21R 56 G2	25 %	0.12	0.4	2830	69.0	0.78	0.32	4.5	2.1	2.1	2.3	0.00013	4.5	
	40 %	0.12	0.4	2830	69.0	0.78	0.32	4.5	2.1	2.1	2.3			
	60 %	0.12	0.4	2830	69.0	0.78	0.32	4.5	2.1	2.1	2.3			
K21R 63 K2	K20R 56 K2	25 %	0.23	0.8	2700	63	0.86	0.61	3.5	1.6	1.5	1.8	0.00013	4.9
		40 %	0.23	0.8	2710	63	0.86	0.61	3.5	1.6	1.5	1.8		
		60 %	0.22	0.8	2700	63.0	0.86	0.59	3.6	1.6	1.5	1.9		
K21R 63 G2	K20R 56 G2	25 %	0.35	1.3	2660	65	0.86	0.90	3.7	1.8	1.7	1.9	0.00015	5.2
		40 %	0.35	1.3	2660	65	0.86	0.90	3.7	1.8	1.7	1.9		
		60 %	0.33	1.2	2680	65.0	0.85	0.86	3.8	1.9	1.8	2.0		
K21R 71 K2	K20R 63 K2	25 %	0.45	1.6	2690	68	0.88	1.08	3.9	1.5	1.5	1.7	0.00025	6.7
		40 %	0.45	1.6	2690	68	0.88	1.08	3.9	1.5	1.5	1.7		
		60 %	0.42	1.5	2720	68.0	0.87	1.02	4.2	1.6	1.6	1.8		
K21R 71 G2	K20R 63 G2	25 %	0.75	2.7	2640	69	0.90	1.73	3.7	1.6	1.7	1.8	0.00032	7.6
		40 %	0.75	2.7	2680	70	0.88	1.76	3.8	1.5	1.5	1.7		
		60 %	0.65	2.3	2750	72.0	0.84	1.55	4.3	1.7	1.7	2.0		
K21R 80 K2	K20R 71 K2	25 %	1.00	3.6	2680	70	0.90	2.30	4.3	2.0	1.8	2.0	0.00057	10.7
		40 %	1.00	3.6	2680	70	0.90	2.30	4.3	2.0	1.8	2.0		
		60 %	0.90	3.1	2760	72.0	0.87	2.1	4.8	2.2	2.0	2.3		
K21R 80 G2	K20R 71 G2	25 %	1.5	5.3	2715	73	0.88	3.37	4.4	1.6	1.6	1.8	0.00072	11.5
		40 %	1.5	5.3	2715	73	0.88	3.37	4.4	1.6	1.6	1.8		
		60 %	1.35	4.7	2760	74.0	0.86	3.05	4.9	1.8	1.8	2.0		
K21R 90 S2	K20R 80 K2	25 %	2.1	7.3	2750	77.5	0.90	4.35	4.9	1.9	1.7	1.9	0.00132	16.0
		40 %	2.1	7.2	2800	78	0.88	4.35	5.3	1.8	1.6	1.8		
		60 %	1.8	6.1	2820	78.0	0.85	3.92	6.0	2.1	1.9	2.1		
K21R 90 L2	K20R 80 G2	25 %	3	10.4	2760	78	0.90	6.20	5.3	2.0	1.8	2.1	0.0017	19.0
		40 %	3	10.4	2760	78	0.90	6.20	5.3	2.0	1.8	2.1		
		60 %	2.7	9.2	2790	79.0	0.89	5.55	5.9	2.3	2.1	2.4		
K21R 100 L2	K20R 90 L2	25 %	4.0	13.6	2810	81.5	0.89	8.00	5.4	1.5	1.5	2.0	0.00275	25.0
		40 %	4.0	13.6	2810	81.5	0.89	8.00	5.4	1.5	1.5	2.0		
		60 %	3.6	12.2	2820	81.0	0.88	7.3	5.9	1.6	1.6	2.2		
K21R 112 M2	K20R 100 S2	25 %	5.5	18.4	2850	83	0.86	11.10	5.4	1.5	1.5	2.0	0.0045	32
		40 %	5.5	18.4	2850	83	0.86	11.10	5.4	1.5	1.5	2.0		
		60 %	4.8	16.0	2870	83.0	0.85	9.8	6.1	1.5	1.5	2.2		
K21R 132 S2 T	K20R 100 L2	25 %	7.2	24.2	2840	84	0.88	14.10	5.6	1.6	1.4	2.1	0.0055	38
		40 %	7.2	24.2	2840	84	0.88	14.10	5.6	1.6	1.4	2.1		
		60 %	6.5	21.7	2860	84.0	0.87	12.8	6.2	1.8	1.5	2.3		
K21R 132 S2	K20R 112 MY2	25 %	6.9	23	2868	81.5	0.85	14.5	4.6	1.5	1.3	2.2	0.0081	50
		40 %	6.7	22	2880	81.5	0.85	14	4.8	1.6	1.4	2.3		
		60 %	6.5	22	2883	82.0	0.85	13.5	0.4	1.6	1.4	2.4		
K21R 132 SX2	K20R 112 M2	25 %	10.0	33	2860	85.0	0.87	19.5	4.9	1.4	1.0	1.9	0.0110	57
		40 %	10.0	33	2860	85.0	0.87	19.5	4.9	1.4	1.0	1.9		
		60 %	8.8	29	2880	85.5	0.87	17.1	5.6	1.6	1.1	2.1		
K21R 160 M2	K20R 132 M2	25 %	16.5	55	2860	85.0	0.90	31.1	4.5	1.6	1.3	2.0	0.0258	81
		40 %	14.5	48	2875	85.5	0.91	26.9	5.2	1.8	1.5	2.2		
		60 %	12.5	41	2890	86.0	0.90	23.3	6.0	2.1	1.8	2.6		
K21R 160 MX2	K20R 160 S2	25 %	23.0	76	2900	88.0	0.91	41.5	4.6	1.5	1.1	1.9	0.0575	118
		40 %	20.0	66	2910	88.5	0.90	36.2	5.3	1.7	1.3	2.2		
		60 %	17.5	57	2920	88.5	0.90	31.7	6.0	1.9	1.5	2.5		
K21R 160 L2	K20R 160 M2	25 %	27.5	91	2880	87.0	0.90	50.5	4.5	1.5	1.1	1.8	0.0675	134
		40 %	24.5	81	2895	88.0	0.91	44	5.2	1.6	1.3	2.0		
		60 %	21.5	71	2910	88.0	0.92	38.5	5.9	1.9	1.5	2.3		
K21R 180 M2	K20R 180 S2	25 %	30.0	98	2910	87.0	0.90	55.5	4.1	1.3	1.0	1.8	0.105	165
		40 %	29.0	95	2916	88.0	0.90	53	4.2	1.4	1.1	1.9		
		60 %	25.5	83	2928	90.0	0.90	45.5	4.9	1.5	1.2	2.2		

Three-phase motors with squirrel-cage rotor

with surface cooling, intermittent periodic duty S3-25%/40%/60%
for rated voltage, thermal class 155 (F), degree of protection IP 55, 50 Hz
Efficiency determination according to IEC/EN 60034-2

Motor selection data													Design point 400 V, 50 Hz	
Type	c.d.f.	P _B	M _B	n _B	η(100%)	cosφ _B	I _B	I _A /I _B	M _A /M _B	M _S /M _B	M _K /M _B	J	m	
	S3						400 V							
		kW	Nm	rpm	%	-	A	-	-	-	-	kgm ²	kg	
Synchronous speed 3000 rpm – 2-pole version														
K21R 200 L2	K20R 180 M2	25 %	43.0	142	2892	91.0	0.92	74	4.5	1.3	1.0	1.8	0.128	195
		40 %	40.0	132	2901	91.0	0.92	69	4.9	1.4	1.1	1.9		
		60 %	35.0	115	2916	91.0	0.92	60.5	5.5	1.6	1.3	2.2		
K21R 200 LX2	K20R 200 M2	25 %	49.0	160	2916	92.0	0.90	85.5	4.9	1.3	1.0	1.8	0.193	255
		40 %	49.0	160	2922	92.0	0.90	85.5	4.9	1.4	1.0	1.8		
		60 %	43.5	142	2934	92.0	0.90	76	5.5	1.5	1.1	2.0		
K21R 225 M2	K20R 200 L2	25 %	65.0	213	2910	92.0	0.90	113	4.8	1.4	1.0	1.8	0.220	290
		40 %	60.0	196	2925	92.0	0.90	105	5.2	1.5	1.1	1.9		
		60 %	52.5	171	2940	92.0	0.90	91.5	5.9	1.7	1.3	2.2		
K21R 250 M2	K20R 225 M2	25 %	76.0	247	2934	91.0	0.87	139	4.7	1.7	1.2	1.8	0.375	360
		40 %	73.0	237	2936	91.0	0.88	132	4.9	1.7	1.3	1.9		
		60 %	64.5	209	2943	92.0	0.90	112	5.8	2.0	1.4	2.1		
K21R 280 S2	K20R 250 S2	25 %	95.0	316	2868	93.0	0.90	164	4.9	1.3	1.1	1.8	0.650	490
		40 %	95.0	316	2874	93.0	0.91	162	5.0	1.3	1.1	1.8		
		60 %	88.0	292	2880	93.0	0.91	150	5.4	1.4	1.2	1.9		
K21R 280 M2	K20R 250 M2	25 %	130	420	2957	94.0	0.92	217	4.8	1.2	1.0	1.8	0.675	510
		40 %	120	387	2961	94.0	0.92	200	5.3	1.3	1.1	1.9		
		60 %	105	338	2967	94.0	0.91	177	5.9	1.5	1.3	2.2		
K21R 315 S2	K20R 280 S2	25 %	150	484	2958	93.5	0.90	257	5.0	1.3	1.2	1.8	1.21	720
		40 %	145	468	2961	94.0	0.90	247	5.2	1.4	1.3	1.9		
		60 %	125	402	2967	94.0	0.90	213	6.0	1.6	1.5	2.2		
K21R 315 M2	K20R 280 M2	25 %	175	565	2958	94.5	0.89	300	5.1	1.3	1.1	1.8	1.44	800
		40 %	175	564	2961	94.5	0.89	300	5.1	1.3	1.1	1.8		
		60 %	150	483	2967	94.5	0.90	255	6.0	1.5	1.3	2.1		
K21R 315 MX2	K20R 315 S2	25 %	220	710	2958	95.0	0.90	371	4.9	1.4	1.3	1.8	1.76	980
		40 %	210	677	2961	95.0	0.90	355	5.1	1.5	1.4	1.9		
		60 %	185	595	2967	95.0	0.90	312	5.8	1.7	1.6	2.2		
K21R 315 MY2	K20R 315 M2	25 %	300	973	2946	95.0	0.91	501	4.6	1.7	1.5	1.8	2.82	1170
		40 %	265	857	2952	95.0	0.92	438	5.2	2.0	1.7	2.0		
		60 %	230	743	2958	95.0	0.92	380	6.0	2.3	1.9	2.3		
K21R 315 L2	K20R 315 L2	25 %	315	1021	2946	95.5	0.91	523	5.7	1.7	1.1	1.6	3.66	1460
		40 %	330	1068	2952	95.5	0.92	542	5.5	1.6	1.1	1.5		
		60 %	290	936	2958	95.5	0.92	476	6.3	1.8	1.2	1.7		
K21R 315 LX2	K20R 315 LX2	25 %	400	1294	2952	95.5	0.92	657	5.8	1.9	1.1	1.6	4.43	1630
		40 %	400	1294	2952	95.5	0.92	657	5.8	1.9	1.1	1.6		
		60 %	350	1130	2958	95.5	0.92	575	6.6	2.1	1.3	1.8		
K22R 355 MY2		25 %	315	1008	2984	96.8	0.88	534	8.6	1.3	1.0	2.7	4.10	1900
		40 %	315	1008	2984	96.8	0.88	534	8.6	1.3	1.0	2.7		
		60 %	315	1008	2984	96.8	0.88	534	8.6	1.3	1.0	2.7		
K22R 355 M2		25 %	355	1137	2983	96.8	0.91	582	7.3	1.3	1.0	2.7	4.20	2000
		40 %	355	1137	2983	96.8	0.91	582	7.3	1.3	1.0	2.7		
		60 %	355	1137	2983	96.8	0.91	582	7.3	1.3	1.0	2.7		
K22R 355 MX2		25 %	400	1280	2984	96.9	0.91	649	7.5	1.3	1.0	2.6	5.50	2200
		40 %	400	1280	2984	96.9	0.91	649	7.5	1.3	1.0	2.6		
		60 %	400	1280	2984	96.9	0.91	649	7.5	1.3	1.0	2.6		
K22R 355 LY2		25 %	450	1441	2983	97.1	0.91	730	7.7	1.5	1.0	2.6	7.10	2400
		40 %	450	1441	2983	97.1	0.91	730	7.7	1.5	1.0	2.6		
		60 %	450	1441	2983	97.1	0.91	730	7.7	1.5	1.0	2.6		
K22R 355 L2		25 %	500	1599	2986	97.2	0.92	809	8.2	1.8	0.9	2.6	7.10	2400
		40 %	500	1599	2986	97.2	0.92	809	8.2	1.8	0.9	2.6		
		60 %	500	1599	2986	97.2	0.92	809	8.2	1.8	0.9	2.6		

Three-phase motors with squirrel-cage rotor

with surface cooling, intermittent periodic duty S3-25 %/40 %/60 %
for rated voltage, thermal class 155 (F), degree of protection IP 55, 50 Hz
Efficiency determination according to IEC/EN 60034-2

Motor selection data													Design point 400 V, 50 Hz	
Type		c.d.f. S3	P _B kW	M _B Nm	n _B rpm	η(100%) %	cosφ _B -	I _B 400 V A	I _x /I _B -	M _x /M _B -	M _s /M _B -	M _k /M _B -	J kgm ²	m kg
Synchronous speed 1500 rpm – 4-pole version														
K21R 63 K4	K20R 56 K4	25 %	0.15	1.1	1325	56	0.78	0.50	2.8	1.4	1.4	1.7	0.00019	4.8
		40 %	0.15	1.1	1325	56	0.78	0.50	2.8	1.4	1.4	1.7		
		60 %	0.14	1.0	1340	57.5	0.75	0.47	2.9	1.5	1.5	1.9		
K21R 63 G4	K20R 56 G4	25 %	0.23	1.7	1290	59	0.78	0.72	2.9	1.6	1.6	1.7	0.00024	5.2
		40 %	0.23	1.7	1290	59	0.78	0.72	2.9	1.6	1.6	1.7		
		60 %	0.22	1.6	1295	58.0	0.77	0.71	2.9	1.7	1.7	1.8		
K21R 71 K4	K20R 63 K4	25 %	0.30	2.1	1340	61	0.80	0.89	3.0	1.4	1.4	1.6	0.00040	6.8
		40 %	0.30	2.1	1340	61	0.80	0.89	3.0	1.4	1.4	1.6		
		60 %	0.28	2.0	1350	62.0	0.78	0.84	3.2	1.5	1.5	1.7		
K21R 71 G4	K20R 63 G4	25 %	0.45	3.2	1325	64	0.81	1.25	3.3	1.5	1.5	1.7	0.00050	7.8
		40 %	0.45	3.2	1325	64	0.81	1.25	3.3	1.5	1.5	1.7		
		60 %	0.40	2.8	1350	66.0	0.77	1.14	3.6	1.6	1.6	1.9		
K21R 80 K4	K20R 71 K4	25 %	0.75	5.3	1350	67	0.82	1.97	3.3	1.4	1.4	1.7	0.00087	10.6
		40 %	0.75	5.3	1350	67	0.82	1.97	3.3	1.4	1.4	1.7		
		60 %	0.70	4.9	1360	68.0	0.80	1.86	3.5	1.5	1.5	1.8		
K21 80 G4	K20R 71 G4	25 %	1.00	7.0	1360	70	0.80	2.58	3.9	1.7	1.7	1.9	0.00107	11.7
		40 %	1.00	7.0	1360	70	0.80	2.58	3.9	1.7	1.7	1.9		
		60 %	0.90	6.3	1375	71.0	0.77	2.38	4.2	1.9	1.9	2.1		
K21R 90 S4	K20R 80 K4	25 %	1.5	10.6	1350	70	0.89	3.45	4.0	1.3	1.3	1.6	0.00207	15.5
		40 %	1.5	10.6	1350	70	0.89	3.45	4.0	1.3	1.3	1.6		
		60 %	1.4	9.8	1360	70.0	0.87	3.32	4.1	1.4	1.4	1.7		
K21R 90 L4	K20R 80 G4	25 %	2	14.2	1345	72	0.89	4.50	4.2	1.4	1.4	1.7	0.00260	18.0
		40 %	2	14.2	1345	72	0.89	4.50	4.2	1.4	1.4	1.7		
		60 %	1.8	12.6	1365	74.0	0.87	4.05	4.6	1.5	1.5	1.9		
K21R 100 L4	K20R 90 L4	25 %	3	20.8	1380	78	0.86	6.50	4.6	1.8	1.6	1.9	0.00400	23.5
		40 %	3	20.6	1390	77	0.84	6.70	4.8	1.9	1.5	2.0		
		60 %	2.8	19.2	1395	78.0	0.83	6.1	5.1	2.0	1.6	2.2		
K21R 100 LX4	K20R 100 S4	25 %	4.0	27.2	1405	79.5	0.84	8.65	5.0	1.5	1.5	1.9	0.00725	30
		40 %	4.0	27.2	1405	79.5	0.84	8.65	5.0	1.5	1.5	1.9		
		60 %	3.8	25.7	1415	79.5	0.84	8.20	5.3	1.6	1.6	2.0		
K21R 112 M4	K20R 100 L4	25 %	5.5	37.8	1390	81	0.84	11.70	5.3	1.6	1.6	2.2	0.00900	37
		40 %	5.5	37.8	1390	81	0.84	11.70	5.3	1.6	1.6	2.2		
		60 %	5.0	34	1400	80.0	0.84	10.7	5.8	1.8	1.8	2.4		
K21R 132 S4	K20R 112 M4	25 %	8.5	58	1397	81.0	0.89	17	4.0	1.2	1.1	1.9	0.01500	50
		40 %	7.3	49	1413	81.5	0.90	14.5	4.7	1.4	1.3	2.2		
		60 %	6.5	44	1425	82.0	0.89	13	5.3	1.6	1.4	2.5		
K21R 132 M4	K20R 132 S4	25 %	12.0	81	1418	82.5	0.88	24	3.8	1.2	1.0	1.8	0.0280	70
		40 %	10.0	67	1436	84.0	0.87	20	4.5	1.5	1.3	2.2		
		60 %	8.8	58	1443	85.0	0.85	17.5	5.1	1.7	1.4	2.5		
K21R 160 M4	K20R 132 M4	25 %	16.0	107	1425	84.0	0.88	31	4.7	1.5	1.3	2.2	0.0350	92
		40 %	14.5	97	1434	85.0	0.88	28	5.2	1.7	1.4	2.5		
		60 %	12.5	83	1445	85.5	0.86	24.5	6.0	1.9	1.7	2.9		
K21R 160 L4	K20R 160 S4	25 %	22.0	147	1428	86.0	0.86	43	4.8	1.7	1.3	2.0	0.0780	120
		40 %	20.5	135	1449	87.0	0.87	39	5.3	1.8	1.4	2.2		
		60 %	17.5	115	1458	88.0	0.86	33.5	6.2	2.1	1.7	2.6		
K21R 180 M4	K20R 160 M4	25 %	29.0	194	1425	87.0	0.86	56	4.3	1.6	1.2	1.8	0.0900	136
		40 %	25.5	168	1448	87.5	0.87	48.5	4.9	1.8	1.4	2.1		
		60 %	21.5	141	1457	88.0	0.86	41	5.8	2.1	1.7	2.5		
K21R 180 L4	K20R 180 S4	25 %	34.0	225	1445	89.0	0.83	66.5	4.1	1.3	1.1	1.7	0.1380	170
		40 %	31.5	207	1452	89.0	0.84	61	4.5	1.4	1.2	1.8		
		60 %	26.0	170	1458	90.0	0.84	49.5	5.5	1.7	1.5	2.2		
K21R 200 L4	K20R 180 M4	25 %	45.0	297	1446	90.0	0.84	86	3.9	1.3	1.1	1.6	0.1680	200
		40 %	40.0	263	1452	90.0	0.86	74.5	4.5	1.5	1.3	1.9		
		60 %	35.0	229	1458	90.0	0.87	64.5	5.2	1.7	1.5	2.1		
K21R 225 S4	K20R 200 M4	25 %	55.0	361	1454	92.0	0.85	102	4.3	1.3	1.1	1.7	0.2750	270
		40 %	51.0	334	1460	92.0	0.85	94	4.6	1.4	1.2	1.8		
		60 %	45.0	294	1463	92.0	0.85	83	5.2	1.6	1.4	2.0		
K21R 225 M4	K20R 200 L4	25 %	65.0	429	1448	93.0	0.83	122	4.3	1.5	1.2	1.7	0.3130	300
		40 %	62.5	411	1452	93.0	0.83	117	4.5	1.6	1.2	1.8		
		60 %	55.0	360	1460	92.0	0.85	102	5.2	1.8	1.4	2.0		

Three-phase motors with squirrel-cage rotor

with surface cooling, intermittent periodic duty S3-25%/40%/60%
for rated voltage, thermal class 155 (F), degree of protection IP 55, 50 Hz
Efficiency determination according to IEC/EN 60034-2

Motor selection data												Design point 400 V, 50 Hz		
Type	c.d.f.	P _B	M _B	n _B	η(100%)	cosφ _B	I _B	I _x /I _B	M _x /M _B	M _s /M _B	M _k /M _B	J	m	
	S3						400 V							
		kW	Nm	rpm	%	-	A	-	-	-	-	kgm ²	kg	
Synchronous speed 1500 rpm – 4-pole version														
K21R 250 M4	K20R 225 M4	25 %	75.0	489	1464	92.0	0.85	138	5.0	1.7	1.3	1.7	0.5250	375
		40 %	70.0	456	1467	92.0	0.85	129	5.3	1.9	1.4	1.8		
		60 %	65.0	422	1470	92.0	0.85	120	5.7	2.0	1.5	1.9		
K21R 280 S4	K20R 250 S4	25 %	95.0	618	1467	92.0	0.84	177	5.3	1.6	1.3	1.7	0.9500	520
		40 %	91.0	592	1469	92.0	0.84	170	5.5	1.6	1.4	1.8		
		60 %	85.0	551	1473	93.0	0.85	155	6.1	1.8	1.5	1.9		
K21R 280 M4	K20R 250 M4	25 %	115	745	1474	94.0	0.84	210	5.3	1.6	1.2	1.7	1.10	580
		40 %	110	712	1475	94.2	0.84	201	5.6	1.7	1.3	1.8		
		60 %	105	679	1476	94.0	0.85	190	5.9	1.8	1.4	1.9		
K21R 315 S4	K20R 280 S4	25 %	155	1002	1478	93.5	0.85	282	4.8	1.5	1.3	1.7	1.96	740
		40 %	145	936	1479	94.0	0.85	262	5.2	1.6	1.4	1.8		
		60 %	130	838	1482	94.0	0.85	235	5.8	1.8	1.6	2.0		
K21R 315 M4	K20R 280 M4	25 %	185	1199	1473	94.0	0.85	334	4.8	1.5	1.3	1.7	2.27	840
		40 %	175	1134	1474	94.0	0.85	316	5.1	1.6	1.4	1.8		
		60 %	155	1001	1479	94.0	0.85	280	5.8	1.8	1.5	2.0		
K21R 315 MX4	K20R 315 S4	25 %	205	1329	1473	94.0	0.85	370	4.9	1.4	1.3	1.7	2.73	1000
		40 %	195	1263	1475	94.0	0.86	348	5.2	1.5	1.4	1.8		
		60 %	185	1197	1476	94.0	0.86	330	5.5	1.6	1.5	1.9		
K21R 315 MY4	K20R 315 M4	25 %	275	1781	1475	95.0	0.87	480	4.9	1.4	1.3	1.7	4.82	1200
		40 %	265	1715	1476	95.0	0.87	463	5.0	1.5	1.4	1.8		
		60 %	235	1517	1479	95.0	0.88	406	5.7	1.7	1.5	2.0		
K21R 315 L4	K20R 315 L4	25 %	315	2039	1475	95.5	0.88	541	6.2	1.6	1.3	1.8	5.93	1450
		40 %	305	1973	1476	95.5	0.88	524	6.4	1.6	1.3	1.9		
		60 %	290	1873	1479	95.5	0.88	498	6.8	1.7	1.4	2.0		
K21R 315 LX4	K20R 315 LX4	25 %	390	2510	1484	96.0	0.86	682	6.7	1.5	1.2	2.0	6.82	1630
		40 %	375	2412	1485	96.0	0.87	648	7.1	1.6	1.3	2.1		
		60 %	360	2310	1488	96.0	0.87	622	7.4	1.7	1.3	2.2		
K22R 355 MY4		25 %	315	2019	1490	96.5	0.84	560	7.1	1.4	1.0	2.9	5.60	1950
		40 %	315	2019	1490	96.5	0.84	560	7.1	1.4	1.0	2.9		
		60 %	315	2019	1490	96.5	0.84	560	7.1	1.4	1.0	2.9		
K22R 355 M4		25 %	355	2272	1492	96.8	0.85	623	8.1	1.8	1.0	3.1	7.9	2150
		40 %	355	2272	1492	96.8	0.85	623	8.1	1.8	1.0	3.1		
		60 %	355	2272	1492	96.8	0.85	623	8.1	1.8	1.0	3.1		
K22R 355 MX4		25 %	400	2560	1492	96.8	0.84	710	8.6	1.8	1.0	3.4	9.5	2400
		40 %	400	2560	1492	96.8	0.84	710	8.6	1.8	1.0	3.4		
		60 %	400	2560	1492	96.8	0.84	710	8.6	1.8	1.0	3.4		
K22R 355 LY4		25 %	450	2878	1493	96.8	0.82	818	8.0	1.9	1.0	3.6	10.0	2500
		40 %	450	2878	1493	96.8	0.82	818	8.0	1.9	1.0	3.6		
		60 %	450	2878	1493	96.8	0.82	818	8.0	1.9	1.0	3.6		
K22R 355 L4		25 %	500	3205	1490	96.7	0.79	945	7.9	1.9	1.0	3.6	10.0	2500
		40 %	500	3205	1490	96.7	0.79	945	7.9	1.9	1.0	3.6		
		60 %	500	3205	1490	96.7	0.79	945	7.9	1.9	1.0	3.6		

Three-phase motors with squirrel-cage rotor

with surface cooling, intermittent periodic duty S3-25 %/40 %/60 %
for rated voltage, thermal class 155 (F), degree of protection IP 55, 50 Hz
Efficiency determination according to IEC/EN 60034-2

Motor selection data													Design point 400 V, 50 Hz	
Type		c.d.f. S3	P _B kW	M _B Nm	n _B rpm	η(100%) %	cosφ _B -	I _B 400 V A	I _A /I _B -	M _A /M _B -	M _S /M _B -	M _K /M _B -	J kgm ²	m kg
Synchronous speed 1000 rpm – 6-pole version														
K21R 63 K6	K20R 56 K6	25 %	0.12	1.4	835	50	0.65	0.54	2.1	1.5	1.5	1.6	0.00024	4.9
		40 %	0.12	1.4	835	50	0.65	0.54	2.1	1.5	1.5	1.6		
		60 %	0.11	1.2	850	48.0	0.64	0.52	2.2	1.7	1.7	1.8		
K21R 63 G6	K20R 56 G6	25 %	0.15	1.7	845	50	0.64	0.68	2.2	1.4	1.4	1.6	0.00027	5.7
		40 %	0.15	1.7	845	50	0.64	0.68	2.2	1.4	1.4	1.6		
		60 %	0.14	1.6	855	50.0	0.62	0.65	2.3	1.5	1.5	1.8		
K21R 71 K6	K20R 63 K6	25 %	0.25	2.7	875	56	0.65	0.99	2.5	1.5	1.5	1.6	0.00045	7.4
		40 %	0.25	2.7	875	56	0.65	0.99	2.5	1.5	1.5	1.6		
		60 %	0.23	2.5	890	57.0	0.62	0.94	2.6	1.6	1.6	1.8		
K21R 71 G6	K20R 63 G6	25 %	0.30	3.3	875	59	0.60	1.23	2.6	1.6	1.6	1.8	0.00060	8.3
		40 %	0.30	3.3	875	59	0.60	1.23	2.6	1.6	1.6	1.8		
		60 %	0.28	3.0	880	58.0	0.59	1.18	2.8	1.7	1.7	1.9		
K21R 80 K6	K20R 71 K6	25 %	0.45	4.8	900	64	0.76	1.34	3.1	1.3	1.3	1.6	0.00130	11.0
		40 %	0.45	4.8	900	64	0.76	1.34	3.1	1.3	1.3	1.6		
		60 %	0.42	4.4	905	64.0	0.74	1.28	3.3	1.4	1.4	1.7		
K21R 80 G6	K20R 71 G6	25 %	0.65	6.9	900	65	0.75	1.93	3.2	1.5	1.5	1.8	0.00175	12.5
		40 %	0.65	6.9	900	65	0.75	1.93	3.2	1.5	1.5	1.8		
		60 %	0.60	6.3	905	65.0	0.72	1.85	3.4	1.6	1.6	2.0		
K21R 90 S6	K20R 80 K6	25 %	1.00	10.4	915	67.5	0.72	2.97	3.5	1.4	1.4	1.9	0.00325	16.0
		40 %	1.00	10.4	915	67.5	0.72	2.97	3.5	1.4	1.4	1.9		
		60 %	0.90	9.3	925	68.0	0.69	2.75	3.8	1.6	1.6	2.1		
K21R 90 L6	K20R 80 G6	25 %	1.5	15.9	900	69	0.76	4.15	3.4	1.5	1.5	1.7	0.00425	19.0
		40 %	1.5	15.9	900	69	0.76	4.15	3.4	1.5	1.5	1.7		
		60 %	1.4	14.8	905	68.0	0.75	3.95	3.6	1.6	1.6	1.8		
K21R 100 L6	K20R 90 L6	25 %	2	20.9	915	72	0.77	5.20	3.6	1.3	1.3	1.6	0.00625	24.0
		40 %	2	20.9	915	72	0.77	5.20	3.6	1.3	1.3	1.6		
		60 %	1.8	18.6	925	74.0	0.74	4.75	3.9	1.5	1.5	1.8		
K21R 112 M6	K20R 100 L6	25 %	3	31.1	920	76	0.84	6.80	4.2	1.5	1.5	1.9	0.01225	33.5
		40 %	3	31.1	920	76	0.84	6.80	4.2	1.5	1.5	1.9		
		60 %	2.8	28.9	925	77.0	0.83	6.35	4.5	1.6	1.6	2.0		
K21R 132 S6	K20R 112 M6	25 %	5.0	53	908	71.0	0.87	11.5	3.3	1.1	1.0	1.6	0.0180	46
		40 %	4.6	48	915	73.0	0.86	10.5	3.6	1.3	1.1	1.8		
		60 %	3.5	35	943	78.0	0.82	8	4.7	1.7	1.5	2.4		
K21R 132 M6	K20R 112 MX6	25 %	7.0	73	912	72.0	0.86	16.5	3.3	1.3	1.1	1.6	0.0230	53
		40 %	6.2	65	916	76.0	0.86	13.5	4.0	1.4	1.2	1.9		
		60 %	4.7	48	941	79.0	0.82	10.5	5.1	1.9	1.7	2.5		
K21R 132 MX6	K20R 132 S6	25 %	8.0	82	930	77.0	0.85	17.5	3.3	1.3	1.1	1.6	0.0430	70
		40 %	7.3	74	938	79.0	0.85	15.5	3.7	1.4	1.3	1.8		
		60 %	6.5	66	947	81.0	0.84	13.5	4.3	1.6	1.4	2.0		
K21R 160 M6	K20R 132 M6	25 %	12.0	123	932	77.0	0.84	27	3.2	1.2	1.0	1.5	0.0530	86
		40 %	10.5	106	944	81.0	0.84	22.5	3.8	1.4	1.1	1.8		
		60 %	8.8	88	953	82.0	0.84	18.5	4.6	1.7	1.4	2.1		
K21R 160 L6	K20R 160 S6	25 %	16.0	163	939	85.0	0.88	31	3.5	1.3	1.1	1.5	0.1130	114
		40 %	14.0	141	949	85.0	0.87	27.5	4.0	1.5	1.3	1.8		
		60 %	12.5	125	955	85.0	0.87	24.5	4.5	1.7	1.5	2.0		
K21R 180 L6	K20R 160 M6	25 %	24.0	244	940	85.0	0.83	49	3.4	1.5	1.3	1.6	0.1450	136
		40 %	22.5	227	945	85.0	0.83	46	3.6	1.6	1.4	1.8		
		60 %	17.5	174	960	85.0	0.82	36	4.7	2.0	1.9	2.3		
K21R 200 L6	K20R 180 S6	25 %	26.0	263	944	86.0	0.88	49.5	3.9	1.4	1.2	1.7	0.2280	175
		40 %	24.5	246	952	86.0	0.88	46.5	4.2	1.5	1.3	1.8		
		60 %	21.0	209	960	87.0	0.87	40	4.9	1.8	1.5	2.1		
K21R 200 LX6	K20R 180 M6	25 %	35.0	354	943	87.0	0.86	67.5	3.6	1.3	1.1	1.6	0.2680	200
		40 %	33.0	333	947	87.0	0.86	63.5	3.9	1.4	1.2	1.8		
		60 %	25.0	248	962	88.0	0.86	47.5	5.2	1.8	1.6	2.4		
K21R 225 M6	K20R 200 M6	25 %	45.0	452	950	89.0	0.88	83	4.0	1.4	1.1	1.6	0.4430	265
		40 %	41.5	415	955	89.0	0.88	76.5	4.3	1.6	1.2	1.8		
		60 %	35.0	347	964	89.0	0.88	64.5	5.1	1.9	1.4	2.1		
K21R 250 M6	K20R 225 M6	25 %	50.0	497	960	88.0	0.86	95.5	4.1	1.5	1.1	1.7	0.8250	360
		40 %	47.0	466	963	89.0	0.87	87.5	4.5	1.6	1.2	1.8		
		60 %	43.5	430	966	90.0	0.89	78.5	5.0	1.7	1.3	1.9		

Three-phase motors with squirrel-cage rotor

with surface cooling, intermittent periodic duty S3-25%/40%/60%
for rated voltage, thermal class 155 (F), degree of protection IP 55, 50 Hz
Efficiency determination according to IEC/EN 60034-2

Motor selection data												Design point 400 V, 50 Hz		
Type	c.d.f.	P _B	M _B	n _B	η(100%)	cosφ _B	I _B	I _A /I _B	M _A /M _B	M _S /M _B	M _K /M _B	J	m	
	S3						400 V							
		kW	Nm	rpm	%	-	A	-	-	-	-	kgm ²	kg	
Synchronous speed 1000 rpm – 6-pole version														
K21R 280 S6	K20R 250 S6	25 %	55.0	539	975	90.0	0.86	103	4.7	1.6	1.2	1.6	1.28	465
		40 %	55.0	539	975	90.0	0.86	103	4.7	1.6	1.2	1.6		
		60 %	52.0	508	978	91.0	0.86	96	5.1	1.7	1.3	1.7		
K21R 280 M6	K20R 250 M6	25 %	72.0	705	975	90.0	0.85	136	4.3	1.6	1.2	1.7	1.48	520
		40 %	67.0	654	978	92.0	0.87	121	4.8	1.7	1.3	1.8		
		60 %	64.0	624	979	92.0	0.87	115	5.1	1.8	1.4	1.9		
K21R 315 S6	K20R 280 S6	25 %	110	1072	980	92.5	0.86	200	4.3	1.4	1.2	1.6	2.63	690
		40 %	100	973	982	93.0	0.86	180	4.8	1.5	1.3	1.8		
		60 %	88	853	985	93.0	0.87	157	5.5	1.7	1.4	2.0		
K21R 315 M6	K20R 280 M6	25 %	130	1267	980	93.0	0.86	235	4.3	1.4	1.2	1.6	3.33	800
		40 %	120	1166	983	93.0	0.86	217	4.7	1.5	1.3	1.8		
		60 %	105	1018	985	94.0	0.87	185	5.5	1.7	1.4	2.0		
K21R 315 MX6	K20R 315 S6	25 %	165	1611	978	93.0	0.86	298	4.5	1.5	1.3	1.7	3.60	880
		40 %	155	1510	980	93.0	0.86	280	4.8	1.6	1.3	1.8		
		60 %	125	1214	983	93.8	0.87	221	6.1	2.0	1.7	2.3		
K21R 315 MY6	K20R 315 M6	25 %	200	1953	978	94.5	0.88	347	4.6	1.6	1.3	1.7	6.00	1050
		40 %	190	1852	980	94.5	0.88	330	4.8	1.7	1.4	1.8		
		60 %	155	1503	985	94.5	0.88	269	5.9	2.0	1.7	2.2		
K21R 315 L6	K20R 315 L6	25 %	220	2148	978	94.5	0.88	382	5.4	1.7	1.4	1.7	6.67	1250
		40 %	210	2046	980	94.5	0.88	364	5.7	1.7	1.4	1.8		
		60 %	185	1794	985	94.5	0.88	321	6.4	2.0	1.6	2.1		
K21R 315 LX6	K20R 315 LX6	25 %	270	2637	978	94.0	0.85	488	5.9	1.6	1.5	2.0	8.6	1460
		40 %	250	2431	982	94.5	0.86	444	6.5	1.7	1.6	2.1		
		60 %	235	2269	989	95.0	0.86	415	7.0	1.9	1.7	2.3		
K22R 355 MY6		25 %	200	1922	994	96.0	0.88	342	6.6	1.4	1.0	2.5	8.1	1550
		40 %	200	1922	994	96.0	0.88	342	6.6	1.4	1.0	2.5		
		60 %	200	1922	994	96.0	0.88	342	6.6	1.4	1.0	2.5		
K22R 355 M6		25 %	250	2402	994	96.0	0.84	447	7.4	1.6	1.1	2.9	8.2	1650
		40 %	250	2402	994	96.0	0.84	447	7.4	1.6	1.1	2.9		
		60 %	250	2402	994	96.0	0.84	447	7.4	1.6	1.1	2.9		
K22R 355 MX6		25 %	315	3029	993	96.6	0.85	554	8.6	1.7	1.1	2.9	12.1	2200
		40 %	315	3029	993	96.6	0.85	554	8.6	1.7	1.1	2.9		
		60 %	315	3029	993	96.6	0.85	554	8.6	1.7	1.1	2.9		
K22R 355 LY6		25 %	355	3414	993	96.6	0.84	631	7.8	1.8	1.0	3.0	14.0	2400
		40 %	355	3414	993	96.6	0.84	631	7.8	1.8	1.0	3.0		
		60 %	355	3414	993	96.6	0.84	631	7.8	1.8	1.0	3.0		

Three-phase motors with squirrel-cage rotor

with surface cooling, intermittent periodic duty S3-25%/40%/60%
for rated voltage, thermal class 155 (F), degree of protection IP 55, 50 Hz
Efficiency determination according to IEC/EN 60034-2

Motor selection data													Design point 400 V, 50 Hz	
Type	c.d.f.	P _B	M _B	n _B	η(100%)	cosφ _B	I _B	I _A /I _B	M _A /M _B	M _S /M _B	M _K /M _B	J	m	
	S3						400 V							
		kW	Nm	rpm	%	-	A	-	-	-	-	kgm ²	kg	
Synchronous speed 750 rpm – 8-pole version														
K21R 71 K8	K20R 63 K8	25 %	0.105	1.5	655	45	0.58	0.58	2.0	1.5	1.5	1.8	0.00050	6.6
		40 %	0.105	1.5	655	45	0.58	0.58	2.0	1.5	1.5	1.8		
		60 %	0.10	1.4	665	44.0	0.58	0.57	2.1	1.6	1.6	1.8		
K21R 71 G8	K20R 63 G8	25 %	0.14	2.0	655	47	0.57	0.75	2.1	1.4	1.4	1.8	0.00060	8.1
		40 %	0.14	2.0	655	47	0.57	0.75	2.1	1.4	1.4	1.8		
		60 %	0.13	1.9	665	46.0	0.56	0.74	2.1	1.5	1.5	1.9		
K21R 80 K8	K20R 71 K8	25 %	0.22	3.1	670	56	0.68	0.83	2.4	1.3	1.3	1.6	0.00130	10.5
		40 %	0.22	3.1	670	56	0.68	0.83	2.4	1.3	1.3	1.6		
		60 %	0.21	3.0	675	56.0	0.67	0.81	2.5	1.4	1.4	1.7		
K21R 80 G8	K20R 71 G8	25 %	0.35	5.1	655	57	0.68	1.30	2.6	1.4	1.4	1.5	0.00175	12.0
		40 %	0.35	5.1	655	57	0.68	1.30	2.6	1.4	1.4	1.5		
		60 %	0.33	4.8	660	56.0	0.68	1.24	2.7	1.5	1.5	1.7		
K21R 90 S8	K20R 80 K8	25 %	0.50	7.0	680	59	0.65	1.87	2.6	1.3	1.3	1.6	0.00300	15.0
		40 %	0.50	7.0	680	59	0.65	1.87	2.6	1.3	1.3	1.6		
		60 %	0.45	6.2	690	60.0	0.62	1.75	2.8	1.4	1.4	1.8		
K21R 90 L8	K20R 80 G8	25 %	0.70	9.8	680	64	0.64	2.48	2.8	1.4	1.4	1.7	0.00375	18.0
		40 %	0.70	9.8	680	64	0.64	2.48	2.8	1.4	1.4	1.7		
		60 %	0.65	9.1	685	64.0	0.62	2.37	2.9	1.5	1.5	1.8		
K21R 100 L8	K20R 90 L8	25 %	0.95	13.2	690	64	0.65	3.30	2.8	1.3	1.3	1.6	0.00625	23.0
		40 %	0.95	13.2	690	64	0.65	3.30	2.8	1.3	1.3	1.6		
		60 %	0.90	12.4	695	64.0	0.64	3.15	2.9	1.4	1.4	1.7		
K21R 100 LX8	K20R 100 S8	25 %	1.5	21.1	680	70	0.76	4.05	3.2	1.4	1.4	1.6	0.00900	28.0
		40 %	1.5	21.1	680	70	0.76	4.05	3.2	1.4	1.4	1.6		
		60 %	1.4	19.5	685	71.0	0.74	3.85	3.4	1.5	1.5	1.8		
K21R 112 M8	K20R 100 L8	25 %	2	27.9	685	72	0.77	5.20	3.3	1.5	1.5	1.7	0.01225	33.5
		40 %	2	27.9	685	72	0.77	5.20	3.3	1.5	1.5	1.7		
		60 %	1.8	24.9	690	74.0	0.75	4.68	3.7	1.7	1.7	1.9		
K21R 132 S8	K20R 112 M8	25 %	2.8	39	694	72.6	0.79	7	0.0	1.3	1.2	1.8	0.01800	46
		40 %	2.8	39	694	72.6	0.79	7	3.2	1.3	1.2	1.8		
		60 %	2.6	36	699	73.5	0.77	6.6	3.4	1.4	1.3	1.9		
K21R 132 M8	K20R 112 MX8	25 %	3.8	53	686	73.6	0.80	9.3	3.2	1.3	1.2	1.8	0.0230	53
		40 %	3.8	53	686	73.6	0.80	9.3	3.2	1.3	1.2	1.8		
		60 %	3.5	48	692	75.0	0.77	8.7	3.4	1.4	1.4	1.9		
K21R 160 M8	K20R 132 S8	25 %	4.2	57	704	77.0	0.78	10	3.8	1.5	1.3	1.8	0.0430	70
		40 %	4.2	57	704	77.0	0.78	10	3.8	1.5	1.3	1.8		
		60 %	4.2	57	704	77.0	0.78	10	3.8	1.5	1.3	1.8		
K21R 160 MX8	K20R 132 M8	25 %	6.4	86	707	79.0	0.78	15	3.5	1.5	1.4	1.8	0.0530	86
		40 %	6.4	86	707	79.0	0.78	15	3.5	1.5	1.4	1.8		
		60 %	6.4	86	707	79.0	0.78	15	3.5	1.5	1.4	1.8		
K21R 160 L8	K20R 160 S8	25 %	8.8	117	720	81.0	0.78	20	3.7	1.5	1.4	1.8	0.1130	114
		40 %	8.8	117	720	81.0	0.78	20	3.7	1.5	1.4	1.8		
		60 %	8.8	117	720	81.0	0.78	20	3.7	1.5	1.4	1.8		
K21R 180 L8	K20R 160 M8	25 %	12.8	171	714	84.0	0.79	28	3.9	1.7	1.4	1.8	0.1450	136
		40 %	12.8	171	714	84.0	0.79	28	3.9	1.7	1.4	1.8		
		60 %	12.8	171	714	84.0	0.79	28	3.9	1.7	1.4	1.8		
K21R 200 L8	K20R 180 S8	25 %	19.2	257	714	84.0	0.80	41	4.0	1.5	1.3	1.8	0.228	175
		40 %	19.2	257	714	84.0	0.80	41	4.0	1.5	1.3	1.8		
		60 %	17.6	233	720	85.0	0.78	38.5	4.2	1.7	1.4	1.9		
	K20R 180 M8	25 %	23.5	316	711	86.0	0.82	48	4.0	1.6	1.3	1.7	0.268	200
		40 %	23.5	316	711	86.0	0.82	48	4.0	1.6	1.3	1.7		
		60 %	21.5	287	716	86.0	0.82	44	4.3	1.7	1.5	1.9		
K21R 225 S8		25 %	22.5	297	724	87.5	0.83	44.5	4.3	1.6	1.3	1.8	0.440	265
		40 %	22.5	297	724	87.5	0.83	44.5	4.3	1.6	1.3	1.8		
		60 %	21.5	283	726	88.0	0.82	43	4.4	1.7	1.4	1.9		
K21R 225 M8	K20R 200 M8	25 %	28.0	373	716	87.5	0.84	55	4.0	1.4	1.2	1.7	0.440	265
		40 %	28.0	373	716	87.5	0.84	55	4.0	1.4	1.2	1.7		
		60 %	25.5	338	720	88.5	0.84	49.5	4.5	1.5	1.3	1.9		
K21R 250 M8	K20R 225 M8	25 %	36.5	479	727	89.0	0.80	74	4.5	1.8	1.5	1.8	0.825	360
		40 %	36.5	479	727	89.0	0.80	74	4.5	1.8	1.5	1.8		
		60 %	35.0	459	728	90.0	0.80	70	4.7	1.9	1.5	1.9		

Three-phase motors with squirrel-cage rotor

with surface cooling, intermittent periodic duty S3-25%/40%/60%
for rated voltage, thermal class 155 (F), degree of protection IP 55, 50 Hz
Efficiency determination according to IEC/EN 60034-2

Motor selection data													Design point 400 V, 50 Hz	
Type	c.d.f.	P _B	M _B	n _B	η(100%)	cosφ _B	I _B	I _x /I _B	M _x /M _B	M _s /M _B	M _k /M _B	J	m	
	S3						400 V							
		kW	Nm	rpm	%	-	A	-	-	-	-	kgm ²	kg	
Synchronous speed 750 rpm – 8-pole version														
K21R 280 S8	K20R 250 S8	25 %	45.0	588	731	90.0	0.80	90	4.5	1.6	1.2	1.6	1.35	465
		40 %	45.0	588	731	90.0	0.80	90	4.5	1.6	1.2	1.6		
		60 %	41.0	535	732	90.0	0.80	82	4.9	1.8	1.3	1.8		
K21R 280 M8	K20R 250 M8	25 %	55.0	717	733	91.0	0.79	110	4.6	1.8	1.2	1.6	1.55	520
		40 %	55.0	717	733	91.0	0.79	110	4.6	1.8	1.2	1.6		
		60 %	50.0	651	734	91.0	0.78	102	5.0	2.0	1.3	1.8		
K21R 315 S8	K20R 280 S8	25 %	73.0	946	737	92.0	0.79	145	4.4	1.5	1.2	1.8	2.63	690
		40 %	73.0	946	737	92.0	0.79	145	4.4	1.5	1.2	1.8		
		60 %	73.0	946	737	92.0	0.79	145	4.4	1.5	1.2	1.8		
K21R 315 M8	K20R 280 M8	25 %	100	1319	724	92.0	0.79	199	4.3	1.5	1.2	1.7	3.33	800
		40 %	100	1319	724	92.0	0.79	199	4.3	1.5	1.2	1.7		
		60 %	95	1250	726	92.0	0.81	184	4.7	1.5	1.2	1.8		
K21R 315 MX8	K20R 315 S8	25 %	110	1429	735	93.0	0.81	211	4.9	1.6	1.4	2.0	3.60	880
		40 %	110	1429	735	93.0	0.81	211	4.9	1.6	1.4	2.0		
		60 %	110	1429	735	93.0	0.81	211	4.9	1.6	1.4	2.0		
K21R 315 MY8	K20R 315 M8	25 %	160	2076	736	92.0	0.80	314	4.0	1.6	1.4	1.8	6.00	1050
		40 %	160	2076	736	92.0	0.80	314	4.0	1.6	1.4	1.8		
		60 %	150	1944	737	93.0	0.80	291	4.3	1.8	1.5	1.9		
K21R 315 L8	K20R 315 L8	25 %	165	2138	737	94.0	0.82	309	5.0	1.6	1.4	1.7	6.76	1250
		40 %	165	2138	737	94.0	0.82	309	5.0	1.6	1.4	1.7		
		60 %	155	2008	737	94.5	0.82	289	5.3	1.7	1.4	1.8		
K21R 315 LX8	K20R 315 LX8	25 %	210	2736	733	93.0	0.77	423	5.2	1.7	1.4	1.9	8.71	1430
		40 %	200	2602	734	94.0	0.77	399	5.5	1.7	1.5	2.0		
		60 %	180	2339	735	95.0	0.78	351	6.3	1.9	1.7	2.2		
K22R 355 MY8		25 %	160	2051	745	95.2	0.80	303	6.8	1.6	1.2	2.7	9.3	1500
		40 %	160	2051	745	95.2	0.80	303	6.8	1.6	1.2	2.7		
		60 %	160	2051	745	95.2	0.80	303	6.8	1.6	1.2	2.7		
K22R 355 M8		25 %	200	2567	744	95.6	0.77	392	6.5	1.6	1.2	2.7	9.5	1600
		40 %	200	2567	744	95.6	0.77	392	6.5	1.6	1.2	2.7		
		60 %	200	2567	744	95.6	0.77	392	6.5	1.6	1.2	2.7		
K22R 355 MX8		25 %	250	3209	744	95.9	0.79	472	6.6	1.6	1.2	2.8	13.4	2200
		40 %	250	3209	744	95.9	0.79	472	6.6	1.6	1.2	2.8		
		60 %	250	3209	744	95.9	0.79	472	6.6	1.6	1.2	2.8		
K22R 355 LY8		25 %	280	3594	744	95.8	0.74	565	7.2	1.9	1.2	3.0	15.8	2400
		40 %	280	3594	744	95.8	0.74	565	7.2	1.9	1.2	3		
		60 %	280	3594	744	95.8	0.74	565	7.2	1.9	1.2	3		

Three-phase motors with squirrel-cage rotor

with surface cooling, duty type S6, continuous operation with periodic duty 25 %/40 %/60 %/80 % for rated voltage, thermal class 155 (F), degree of protection IP 55, 50 Hz Efficiency determination according to IEC/EN 60034-2

Motor selection data													Design point 400 V, 50 Hz	
Type		c.d.f. S6	P _B kW	M _B Nm	n _B rpm	η(100%) %	cosφ _B -	I _B A	I _x /I _B -	M _x /M _B -	M _s /M _B -	M _k /M _B -	J kgm ²	m kg
Synchronous speed 3000 rpm – 2-pole version														
K21R 63 K2	K20R 56 K2	25 %	0.23	0.8	2700	63	0.86	0.61	3.5	1.6	1.5	1.8	0.00013	4.9
		40 %	0.23	0.8	2710	63	0.86	0.61	3.5	1.6	1.5	1.8		
		60 %	0.22	0.8	2700	63.0	0.86	0.59	3.6	1.6	1.5	1.9		
		80 %	0.18	0.6	2790	67.1	0.76	0.51	4.1	1.9	1.9	2.2		
K21R 63 G2	K20R 56 G2	25 %	0.35	1.3	2660	65	0.86	0.90	3.7	1.8	1.7	1.9	0.00015	5.2
		40 %	0.35	1.3	2660	65	0.86	0.90	3.7	1.8	1.7	1.9		
		60 %	0.33	1.2	2680	65.0	0.85	0.86	3.8	1.9	1.8	2.0		
		80 %	0.25	0.9	2800	68.1	0.72	0.74	4.2	2.2	2.2	2.4		
K21R 71 K2	K20R 63 K2	25 %	0.45	1.6	2690	68	0.88	1.08	3.9	1.5	1.5	1.7	0.00025	6.7
		40 %	0.45	1.6	2690	68	0.88	1.08	3.9	1.5	1.5	1.7		
		60 %	0.42	1.5	2720	68.0	0.87	1.02	4.2	1.6	1.6	1.8		
		80 %	0.37	1.3	2780	71.5	0.79	0.94	4.4	2.1	2.1	2.3		
K21R 71 G2	K20R 63 G2	25 %	0.75	2.7	2640	69	0.90	1.73	3.7	1.6	1.7	1.8	0.00032	7.6
		40 %	0.75	2.7	2680	70	0.88	1.76	3.8	1.5	1.5	1.7		
		60 %	0.65	2.3	2750	72.0	0.84	1.55	4.3	1.7	1.7	2.0		
		80 %	0.55	1.9	2775	74.3	0.81	1.32	5.1	2.3	2.1	2.6		
K21R 80 K2	K20R 71 K2	25 %	1.00	3.6	2680	70	0.90	2.30	4.3	2.0	1.8	2.0	0.00057	10.7
		40 %	1.00	3.6	2680	70	0.90	2.30	4.3	2.0	1.8	2.0		
		60 %	0.90	3.1	2760	72.0	0.87	2.1	4.8	2.2	2.0	2.3		
		80 %	0.75	2.5	2825	77.5	0.81	1.72	5.9	2.4	2.4	2.4		
K21R 80 G2	K20R 71 G2	25 %	1.5	5.3	2715	73	0.88	3.37	4.4	1.6	1.6	1.8	0.00072	11.5
		40 %	1.5	5.3	2715	73	0.88	3.37	4.4	1.6	1.6	1.8		
		60 %	1.35	4.7	2760	74.0	0.86	3.05	4.9	1.8	1.8	2.0		
		80 %	1.1	3.7	2835	77.8	0.80	2.55	6.0	2.4	2.3	2.6		
K21R 90 S2	K20R 80 K2	25 %	2.1	7.3	2750	77.5	0.90	4.35	4.9	1.9	1.7	1.9	0.00132	16.0
		40 %	2.1	7.2	2800	78	0.88	4.35	5.3	1.8	1.6	1.8		
		60 %	1.8	6.1	2820	78.0	0.85	3.92	6.0	2.1	1.9	2.1		
		80 %	1.5	5.0	2840	81.2	0.86	3.1	7.0	2.5	2.5	2.8		
K21R 90 L2	K20R 80 G2	25 %	3	10.4	2760	78	0.90	6.20	5.3	2.0	1.8	2.1	0.0017	19.0
		40 %	3	10.4	2760	78	0.90	6.20	5.3	2.0	1.8	2.1		
		60 %	2.7	9.2	2790	79.0	0.89	5.55	5.9	2.3	2.1	2.4		
		80 %	2.2	7.4	2850	82.0	0.85	4.55	7.5	2.8	2.3	2.9		
K21R 100 L2	K20R 90 L2	25 %	4.0	13.6	2810	81.5	0.89	8.00	5.4	1.5	1.5	2.0	0.00275	25.0
		40 %	4.0	13.6	2810	81.5	0.89	8.00	5.4	1.5	1.5	2.0		
		60 %	3.6	12.2	2820	81.0	0.88	7.3	5.9	1.6	1.6	2.2		
		80 %	3.0	10.0	2865	83.4	0.84	6.15	6.8	2.4	2.2	2.8		
K21R 112 M2	K20R 100 S2	25 %	5.5	18.4	2850	83	0.86	11.10	5.4	1.5	1.5	2.0	0.0045	32
		40 %	5.5	18.4	2850	83	0.86	11.10	5.4	1.5	1.5	2.0		
		60 %	4.8	16.0	2870	83.0	0.85	9.8	6.1	1.5	1.5	2.2		
		80 %	4.0	13.2	2900	85.0	0.81	8.4	7.0	2.2	2.1	2.9		
K21R 132 S2 T	K20R 100 L2	25 %	7.2	24.2	2840	84	0.88	14.10	5.6	1.6	1.4	2.1	0.0055	38
		40 %	7.2	24.2	2840	84	0.88	14.10	5.6	1.6	1.4	2.1		
		60 %	6.5	21.7	2860	84.0	0.87	12.8	6.2	1.8	1.5	2.3		
		80 %	5.5	18.2	2890	86.3	0.84	11	7.5	2.4	2.2	3.0		
K21R 132 S2	K20R 112MY2	25 %	6.9	23	2868	81.5	0.85	14.5	4.6	1.5	1.3	2.2	0.0081	50
		40 %	6.9	23	2868	81.5	0.85	14.5	4.6	1.5	1.3	2.2		
		60 %	6.7	22	2880	81.5	0.85	14	4.8	1.6	1.4	2.3		
		80 %	6.5	22	2883	82.0	0.85	13.5	5.0	1.6	1.4	2.4		
K21R 132 SX2	K20R 112 M2	25 %	11.5	39	2815	80.5	0.90	23	4.1	1.1	1.1	1.8	0.0110	57
		40 %	11.5	39	2815	80.5	0.90	23	4.1	1.1	1.1	1.8		
		60 %	10.0	34	2840	82.5	0.89	19.5	4.8	1.3	1.2	2.0		
		80 %	8.8	29	2860	82.5	0.88	17.5	5.3	1.4	1.4	2.3		
K21R 160 M2	K20R 132 M2	25 %	16.5	55	2845	84.5	0.92	30.5	4.9	1.5	1.2	2.0	0.0258	81
		40 %	16.5	55	2845	84.5	0.92	30.5	4.9	1.5	1.2	2.0		
		60 %	14.5	48	2870	85.0	0.92	27	5.6	1.7	1.4	2.3		
		80 %	12.5	41	2890	86.0	0.92	23	7.0	1.9	1.6	2.6		
K21R 160 MX2	K20R 160 S2	25 %	23.0	76	2890	89.0	0.89	42	4.5	1.5	1.2	1.9	0.0575	118
		40 %	23.0	76	2890	89.0	0.89	42	4.5	1.5	1.2	1.9		
		60 %	20.0	66	2910	88.0	0.91	36	5.3	1.7	1.3	2.2		
		80 %	17.5	57	2925	89.0	0.91	31	7.4	2.0	1.5	2.5		
K21R 160 L2	K20R 160 M2	25 %	27.5	91	2880	87.0	0.90	50.5	4.5	1.5	1.1	1.8	0.0675	134
		40 %	27.5	91	2880	87.0	0.90	50.5	4.5	1.5	1.1	1.8		
		60 %	24.5	81	2895	88.0	0.91	44	5.2	1.6	1.3	2.0		
		80 %	21.5	71	2910	88.0	0.92	38.5	5.9	1.9	1.5	2.3		

Three-phase motors with squirrel-cage rotor

with surface cooling, duty type S6, continuous operation with periodic duty 25 %/40 %/60 %/80 %
 for rated voltage, thermal class 155 (F), degree of protection IP 55, 50 Hz
 Efficiency determination according to IEC/EN 60034-2

Motor selection data													Design point 400 V, 50 Hz	
Type	c.d.f.	P _B	M _B	n _B	η(100%)	cosφ _B	I _B	I _A /I _B	M _A /M _B	M _S /M _B	M _K /M _B	J	m	
	S6						400 V							
		kW	Nm	rpm	%	-	A	-	-	-	-	kgm ²	kg	
Synchronous speed 3000 rpm – 2-pole version														
K21R 180 M2	K20R 180 S2	25 %	30.0	98	2910	87.0	0.90	55.5	4.1	1.3	1.0	1.8	0.105	165
		40 %	30.0	98	2910	87.0	0.90	55.5	4.1	1.3	1.0	1.8		
		60 %	29.0	95	2916	88.0	0.90	53	4.2	1.4	1.1	1.9		
		80 %	25.5	83	2928	90.0	0.90	45.5	4.9	1.5	1.2	2.2		
K21R 200 L2	K20R 180 M2	25 %	43.0	142	2892	91.0	0.92	74	4.5	1.3	1.0	1.8	0.128	195
		40 %	43.0	142	2892	91.0	0.92	74	4.5	1.3	1.0	1.8		
		60 %	40.0	132	2901	91.0	0.92	69	4.9	1.4	1.1	1.9		
		80 %	35.0	115	2916	91.0	0.92	60.5	5.5	1.6	1.3	2.2		
K21R 200 LX2	K20R 200 M2	25 %	49.0	160	2916	92.0	0.90	85.5	4.9	1.3	1.0	1.8	0.193	255
		40 %	49.0	160	2916	92.0	0.90	85.5	4.9	1.3	1.0	1.8		
		60 %	49.0	160	2922	92.0	0.90	85.5	4.9	1.4	1.0	1.8		
		80 %	43.5	142	2934	92.0	0.90	76	5.5	1.5	1.1	2.0		
K21R 225 M2	K20R 200 L2	25 %	65.0	213	2910	92.0	0.90	113	4.8	1.4	1.0	1.8	0.220	290
		40 %	65.0	213	2910	92.0	0.90	113	4.8	1.4	1.0	1.8		
		60 %	60.0	196	2925	92.0	0.90	105	5.2	1.5	1.1	1.9		
		80 %	52.5	171	2940	92.0	0.90	91.5	5.9	1.7	1.3	2.2		
K21R 250 M2	K20R 225 M2	25 %	76.0	247	2934	91.0	0.87	139	4.7	1.7	1.2	1.8	0.375	360
		40 %	76.0	247	2934	91.0	0.87	139	4.7	1.7	1.2	1.8		
		60 %	73.0	237	2936	91.0	0.88	132	4.9	1.7	1.3	1.9		
		80 %	64.5	209	2943	92.0	0.90	112	5.8	2.0	1.4	2.1		
K21R 280 S2	K20R 250 S2	25 %	95.0	316	2868	93.0	0.90	164	4.9	1.3	1.1	1.8	0.650	490
		40 %	95.0	316	2868	93.0	0.90	164	4.9	1.3	1.1	1.8		
		60 %	95.0	316	2874	93.0	0.91	162	5.0	1.3	1.1	1.8		
		80 %	88.0	292	2880	93.0	0.91	150	5.4	1.4	1.2	1.9		
K21R 280 M2	K20R 250 M2	25 %	130	420	2957	94.0	0.92	217	4.8	1.2	1.0	1.8	0.675	510
		40 %	130	420	2957	94.0	0.92	217	4.8	1.2	1.0	1.8		
		60 %	120	387	2961	94.0	0.92	200	5.3	1.3	1.1	1.9		
		80 %	105	338	2968	94.0	0.91	177	5.9	1.5	1.3	2.2		
K21R 315 S2	K20R 280 S2	25 %	150	484	2958	93.5	0.90	257	5.0	1.3	1.2	1.8	1.21	720
		40 %	150	484	2958	93.5	0.90	257	5.0	1.3	1.2	1.8		
		60 %	145	468	2961	94.0	0.90	247	5.2	1.4	1.3	1.9		
		80 %	125	402	2967	94.0	0.90	213	6.0	1.6	1.5	2.2		
K21R 315 M2	K20R 280 M2	25 %	175	565	2958	94.5	0.89	300	5.1	1.3	1.1	1.8	1.44	800
		40 %	175	565	2958	94.5	0.89	300	5.1	1.3	1.1	1.8		
		60 %	175	564	2961	94.5	0.89	300	5.1	1.3	1.1	1.8		
		80 %	150	483	2967	94.5	0.90	255	6.0	1.5	1.3	2.1		
K21R 315 MX2	K20R 315 S2	25 %	220	710	2958	95.0	0.90	371	4.9	1.4	1.3	1.8	1.76	980
		40 %	220	710	2958	95.0	0.90	371	4.9	1.4	1.3	1.8		
		60 %	210	677	2961	95.0	0.90	355	5.1	1.5	1.4	1.9		
		80 %	185	595	2967	95.0	0.90	312	5.8	1.7	1.6	2.2		
K21R 315 MY2	K20R 315 M2	25 %	300	973	2946	95.0	0.91	501	4.6	1.7	1.5	1.8	2.82	1170
		40 %	300	973	2946	95.0	0.91	501	4.6	1.7	1.5	1.8		
		60 %	265	857	2952	95.0	0.92	438	5.2	2.0	1.7	2.0		
		80 %	230	743	2958	95.0	0.92	380	6.0	2.3	1.9	2.3		
K21R 315 L2	K20R 315 L2	25 %	315	1021	2946	95.5	0.91	523	5.7	1.7	1.1	1.6	3.66	1460
		40 %	315	1021	2946	95.5	0.91	523	5.7	1.7	1.1	1.6		
		60 %	330	1068	2952	95.5	0.92	542	5.5	1.6	1.1	1.5		
		80 %	290	936	2958	95.5	0.92	476	6.3	1.8	1.2	1.7		
K21R 315 LX2	K20R 315 LX2	25 %	400	1294	2952	95.5	0.92	657	5.8	1.9	1.1	1.6	4.43	1630
		40 %	400	1294	2952	95.5	0.92	657	5.8	1.9	1.1	1.6		
		60 %	400	1294	2952	95.5	0.92	657	5.8	1.9	1.1	1.6		
		80 %	350	1130	2958	95.5	0.92	575	6.6	2.1	1.3	1.8		

Three-phase motors with squirrel-cage rotor

with surface cooling, duty type S6, continuous operation with periodic duty 25 %/40 %/60 %/80 % for rated voltage, thermal class 155 (F), degree of protection IP 55, 50 Hz
Efficiency determination according to IEC/EN 60034-2

Motor selection data													Design point 400 V, 50 Hz	
Type		c.d.f. S6	P _B kW	M _B Nm	n _B rpm	η(100%) %	cosφ _B -	I _B 400 V A	I _x /I _B -	M _A /M _B -	M _S /M _B -	M _K /M _B -	J kgm ²	m kg
Synchronous speed 1500 rpm – 4-pole version														
K21R 63 K4	K20R 56 K4	25 %	0.15	1.1	1325	56	0.78	0.50	2.8	1.4	1.4	1.7	0.00019	4.8
		40 %	0.15	1.1	1325	56	0.78	0.50	2.8	1.4	1.4	1.7		
		60 %	0.14	1.0	1340	57.5	0.75	0.47	2.9	1.5	1.5	1.9		
		80 %	0.12	0.8	1370	57.5	0.68	0.44	3.2	1.9	1.8	2.2		
K21R 63 G4	K20R 56 G4	25 %	0.23	1.7	1290	59	0.78	0.72	2.9	1.6	1.6	1.7	0.00024	5.2
		40 %	0.23	1.7	1290	59	0.78	0.72	2.9	1.6	1.6	1.7		
		60 %	0.22	1.6	1295	58.0	0.77	0.71	2.9	1.7	1.7	1.8		
		80 %	0.18	1.3	1360	61.0	0.66	0.65	3.3	2.0	2.0	2.3		
K21R 71 K4	K20R 63 K4	25 %	0.30	2.1	1340	61	0.80	0.89	3.0	1.4	1.4	1.6	0.00040	6.8
		40 %	0.30	2.1	1340	61	0.80	0.89	3.0	1.4	1.4	1.6		
		60 %	0.28	2.0	1350	62.0	0.78	0.84	3.2	1.5	1.5	1.7		
		80 %	0.25	1.7	1385	64.6	0.72	0.78	3.6	1.8	1.8	2.1		
K21R 71 G4	K20R 63 G4	25 %	0.45	3.2	1325	64	0.81	1.25	3.3	1.5	1.5	1.7	0.00050	7.8
		40 %	0.45	3.2	1325	64	0.81	1.25	3.3	1.5	1.5	1.7		
		60 %	0.40	2.8	1350	66.0	0.77	1.14	3.6	1.6	1.6	1.9		
		80 %	0.37	2.6	1370	67.8	0.74	1.06	3.8	2.0	2.0	2.2		
K21R 80 K4	K20R 71 K4	25 %	0.75	5.3	1350	67	0.82	1.97	3.3	1.4	1.4	1.7	0.00087	10.6
		40 %	0.75	5.3	1350	67	0.82	1.97	3.3	1.4	1.4	1.7		
		60 %	0.70	4.9	1360	68.0	0.80	1.86	3.5	1.5	1.5	1.8		
		80 %	0.55	3.8	1400	71.5	0.69	1.60	4.1	2.1	2.0	2.3		
K21 80 G4	K20R 71 G4	25 %	1.00	7.0	1360	70	0.80	2.58	3.9	1.7	1.7	1.9	0.00107	11.7
		40 %	1.00	7.0	1360	70	0.80	2.58	3.9	1.7	1.7	1.9		
		60 %	0.90	6.3	1375	71.0	0.77	2.38	4.2	1.9	1.9	2.1		
		80 %	0.75	5.1	1400	73.5	0.70	2.10	4.6	2.2	2.1	2.3		
K21R 90 S4	K20R 80 K4	25 %	1.5	10.6	1350	70	0.89	3.45	4.0	1.3	1.3	1.6	0.00207	15.5
		40 %	1.5	10.6	1350	70	0.89	3.45	4.0	1.3	1.3	1.6		
		60 %	1.4	9.8	1360	70.0	0.87	3.32	4.1	1.4	1.4	1.7		
		80 %	1.1	7.5	1410	76.6	0.79	2.62	5.5	2.3	2.2	2.5		
K21R 90 L4	K20R 80 G4	25 %	2	14.2	1345	72	0.89	4.50	4.2	1.4	1.4	1.7	0.00260	18.0
		40 %	2	14.2	1345	72	0.89	4.50	4.2	1.4	1.4	1.7		
		60 %	1.8	12.6	1365	74.0	0.87	4.05	4.6	1.5	1.5	1.9		
		80 %	1.5	10.2	1400	78.8	0.81	3.40	5.5	2.5	2.4	2.6		
K21R 100 L4	K20R 90 L4	25 %	3	20.8	1380	78	0.86	6.50	4.6	1.8	1.6	1.9	0.00400	23.5
		40 %	3	20.6	1390	77	0.84	6.70	4.8	1.9	1.5	2.0		
		60 %	2.8	19.2	1395	78.0	0.83	6.1	5.1	2.0	1.6	2.2		
		80 %	2.2	14.9	1410	81.2	0.79	4.95	6.0	2.5	2.3	2.7		
K21R 100 LX4	K20R 100 S4	25 %	4.0	27.2	1405	79.5	0.84	8.65	5.0	1.5	1.5	1.9	0.00725	30
		40 %	4.0	27.2	1405	79.5	0.84	8.65	5.0	1.5	1.5	1.9		
		60 %	3.8	25.7	1415	79.5	0.84	8.20	5.3	1.6	1.6	2.0		
		80 %	3.0	20.0	1430	82.6	0.79	6.65	6.5	2.5	2.2	2.9		
K21R 112 M4	K20R 100 L4	25 %	5.5	37.8	1390	81	0.84	11.70	5.3	1.6	1.6	2.2	0.00900	37
		40 %	5.5	37.8	1390	81	0.84	11.70	5.3	1.6	1.6	2.2		
		60 %	5.0	34.1	1400	80.0	0.84	10.7	5.8	1.8	1.8	2.4		
		80 %	4.0	26.6	1435	85.0	0.78	8.80	6.9	2.6	2.5	3.2		
K21R 132 S4	K20R 112 M4	25 %	8.5	58	1397	81.0	0.89	17	4.0	1.2	1.1	1.9	0.01500	50
		40 %	8.5	58	1397	81.0	0.89	17	4.0	1.2	1.1	1.9		
		60 %	7.3	49	1413	81.5	0.90	14.5	4.7	1.4	1.3	2.2		
		80 %	6.5	44	1425	82.0	0.89	13	5.3	1.6	1.4	2.5		
K21R 132 M4	K20R 132 S4	25 %	12.0	81	1418	82.5	0.88	24	3.8	1.2	1.0	1.8	0.0280	70
		40 %	12.0	81	1418	82.5	0.88	24	3.8	1.2	1.0	1.8		
		60 %	10.0	67	1436	84.0	0.87	20	4.5	1.5	1.3	2.2		
		80 %	8.8	58	1443	85.0	0.85	17.5	5.1	1.7	1.4	2.5		
K21R 160 M4	K20R 132 M4	25 %	16.0	107	1425	84.0	0.88	31	4.7	1.5	1.3	2.2	0.0350	92
		40 %	16.0	107	1425	84.0	0.88	31	4.7	1.5	1.3	2.2		
		60 %	14.5	97	1434	85.0	0.88	28	5.2	1.7	1.4	2.5		
		80 %	12.5	83	1445	85.5	0.86	24.5	6.0	1.9	1.7	2.9		
K21R 160 L4	K20R 160 S4	25 %	22.0	147	1428	86.0	0.86	43	4.8	1.7	1.3	2.0	0.0780	120
		40 %	22.0	147	1428	86.0	0.86	43	4.8	1.7	1.3	2.0		
		60 %	20.5	135	1449	87.0	0.87	39	5.3	1.8	1.4	2.2		

Three-phase motors with squirrel-cage rotor

with surface cooling, duty type S6, continuous operation with periodic duty 25 %/40 %/60 %/80 % for rated voltage, thermal class 155 (F), degree of protection IP 55, 50 Hz
Efficiency determination according to IEC/EN 60034-2

Motor selection data													Design point 400 V, 50 Hz	
Type	c.d.f.	P _B	M _B	n _B	η(100%)	cosφ _B	I _B	I _A /I _B	M _A /M _B	M _S /M _B	M _K /M _B	J	m	
	S6						400 V							
		kW	Nm	rpm	%	-	A	-	-	-	-	kgm ²	kg	
Synchronous speed 1500 rpm – 4-pole version														
K21R 180 M4	K20R 160 M4	80 %	17.5	115	1458	88.0	0.86	33.5	6.2	2.1	1.7	2.6	0.0900	136
		25 %	29.0	194	1425	87.0	0.86	56	4.3	1.6	1.2	1.8		
		40 %	29.0	194	1425	87.0	0.86	56	4.3	1.6	1.2	1.8		
		60 %	25.5	168	1448	87.5	0.87	48.5	4.9	1.8	1.4	2.1		
K21R 180 L4	K20R 180 S4	80 %	21.5	141	1457	88.0	0.86	41	5.8	2.1	1.7	2.5	0.1380	170
		25 %	34.0	225	1445	89.0	0.83	66.5	4.1	1.3	1.1	1.7		
		40 %	34.0	225	1445	89.0	0.83	66.5	4.1	1.3	1.1	1.7		
		60 %	31.5	207	1452	89.0	0.84	61	4.5	1.4	1.2	1.8		
K21R 200 L4	K20R 180 M4	80 %	26.0	170	1458	90.0	0.84	49.5	5.5	1.7	1.5	2.2	0.1680	200
		25 %	45.0	297	1446	90.0	0.84	86	3.9	1.3	1.1	1.6		
		40 %	45.0	297	1446	90.0	0.84	86	3.9	1.3	1.1	1.6		
		60 %	40.0	263	1452	90.0	0.86	74.5	4.5	1.5	1.3	1.9		
K21R 225 S4	K20R 200 M4	80 %	35.0	229	1458	90.0	0.87	64.5	5.2	1.7	1.5	2.1	0.2750	270
		25 %	55.0	361	1454	92.0	0.85	102	4.3	1.3	1.1	1.7		
		40 %	55.0	361	1454	92.0	0.85	102	4.3	1.3	1.1	1.7		
		60 %	51.0	334	1460	92.0	0.85	94	4.6	1.4	1.2	1.8		
K21R 225 M4	K20R 200 L4	80 %	45.0	294	1463	92.0	0.85	83	5.2	1.6	1.4	2.0	0.3130	300
		25 %	65.0	429	1448	93.0	0.83	122	4.3	1.5	1.2	1.7		
		40 %	65.0	429	1448	93.0	0.83	122	4.3	1.5	1.2	1.7		
		60 %	62.5	411	1452	93.0	0.83	117	4.5	1.6	1.2	1.8		
K21R 250 M4	K20R 225 M4	80 %	55.0	360	1460	92.0	0.85	102	5.2	1.8	1.4	2.0	0.5250	375
		25 %	75.0	489	1464	92.0	0.85	138	5.0	1.7	1.3	1.7		
		40 %	75.0	489	1464	92.0	0.85	138	5.0	1.7	1.3	1.7		
		60 %	70.0	456	1467	92.0	0.85	129	5.3	1.9	1.4	1.8		
K21R 280 S4	K20R 250 S4	80 %	65.0	422	1470	92.0	0.85	120	5.7	2.0	1.5	1.9	0.9500	520
		25 %	95.0	618	1467	92.0	0.84	177	5.3	1.6	1.3	1.7		
		40 %	95.0	618	1467	92.0	0.84	177	5.3	1.6	1.3	1.7		
		60 %	91.0	592	1469	92.0	0.84	170	5.5	1.6	1.4	1.8		
K21R 280 M4	K20R 250 M4	80 %	85.0	551	1473	93.0	0.85	155	6.1	1.8	1.5	1.9	1.10	580
		25 %	115	745	1474	94.0	0.84	210	5.3	1.6	1.2	1.7		
		40 %	115	745	1474	94.0	0.84	210	5.3	1.6	1.2	1.7		
		60 %	110	712	1475	94.2	0.84	201	5.6	1.7	1.3	1.8		
K21R 315 S4	K20R 280 S4	80 %	105	679	1476	94.0	0.85	190	5.9	1.8	1.4	1.9	1.96	740
		25 %	155	1002	1478	93.5	0.85	282	4.8	1.5	1.3	1.7		
		40 %	155	1002	1478	93.5	0.85	282	4.8	1.5	1.3	1.7		
		60 %	145	936	1479	94.0	0.85	262	5.2	1.6	1.4	1.8		
K21R 315 M4	K20R 280 M4	80 %	130	838	1482	94.0	0.85	235	5.8	1.8	1.6	2.0	2.27	840
		25 %	185	1199	1473	94.0	0.85	334	4.8	1.5	1.3	1.7		
		40 %	185	1199	1473	94.0	0.85	334	4.8	1.5	1.3	1.7		
		60 %	175	1134	1474	94.0	0.85	316	5.1	1.6	1.4	1.8		
K21R 315 MX4	K20R 315 S4	80 %	155	1001	1479	94.0	0.85	280	5.8	1.8	1.5	2.0	2.73	1000
		25 %	205	1329	1473	94.0	0.85	370	4.9	1.4	1.3	1.7		
		40 %	205	1329	1473	94.0	0.85	370	4.9	1.4	1.3	1.7		
		60 %	195	1263	1475	94.0	0.86	348	5.2	1.5	1.4	1.8		
K21R 315 MY4	K20R 315 M4	80 %	185	1197	1476	94.0	0.86	330	5.5	1.6	1.5	1.9	4.82	1200
		25 %	275	1781	1475	95.0	0.87	480	4.9	1.4	1.3	1.7		
		40 %	275	1781	1475	95.0	0.87	480	4.9	1.4	1.3	1.7		
		60 %	265	1715	1476	95.0	0.87	463	5.0	1.5	1.4	1.8		
K21R 315 L4	K20R 315 L4	80 %	235	1517	1479	95.0	0.88	406	5.7	1.7	1.5	2.0	5.93	1450
		25 %	315	2039	1475	95.5	0.88	541	6.2	1.6	1.3	1.8		
		40 %	315	2039	1475	95.5	0.88	541	6.2	1.6	1.3	1.8		
		60 %	305	1973	1476	95.5	0.88	524	6.4	1.6	1.3	1.9		
K21R 315 LX4	K20R 315 LX4	80 %	290	1873	1479	95.5	0.88	498	6.8	1.7	1.4	2.0	6.82	1630
		25 %	390	2510	1484	96.0	0.86	682	6.7	1.5	1.2	2.0		
		40 %	390	2510	1484	96.0	0.86	682	6.7	1.5	1.2	2.0		
		60 %	375	2412	1485	96.0	0.87	648	7.1	1.6	1.3	2.1		
		80 %	360	2310	1488	96.0	0.87	622	7.4	1.7	1.3	2.2		

Three-phase motors with squirrel-cage rotor

with surface cooling, duty type S6, continuous operation with periodic duty 25 %/40 %/60 %/80 % for rated voltage, thermal class 155 (F), degree of protection IP 55, 50 Hz
Efficiency determination according to IEC/EN 60034-2

Motor selection data													Design point 400 V, 50 Hz	
Type	c.d.f.	P _B	M _B	n _B	η(100%)	cosφ _B	I _B	I _x /I _B	M _A /M _B	M _S /M _B	M _K /M _B	J	m	
		S6					400 V							
		kW	Nm	rpm	%	-	A	-	-	-	-	kgm ²	kg	
Synchronous speed 1000 rpm – 6-pole version														
K21R 63 K6	K20R 56 K6	25 %	0.12	1.4	835	50	0.65	0.54	2.1	1.5	1.5	1.6	0.00024	4.9
		40 %	0.12	1.4	835	50	0.65	0.54	2.1	1.5	1.5	1.6		
		60 %	0.11	1.2	850	48.0	0.64	0.52	2.2	1.7	1.7	1.8		
		80 %	0.09	1.0	895	50.5	0.56	0.46	2.5	2.0	2.0	2.4		
K21R 63 G6	K20R 56 G6	25 %	0.15	1.7	845	50	0.64	0.68	2.2	1.4	1.4	1.6	0.00027	5.7
		40 %	0.15	1.7	845	50	0.64	0.68	2.2	1.4	1.4	1.6		
		60 %	0.14	1.6	855	50.0	0.62	0.65	2.3	1.5	1.5	1.8		
		80 %	0.12	1.3	880	52.0	0.56	0.59	2.5	2.0	2.0	2.3		
K21R 71 K6	K20R 63 K6	25 %	0.25	2.7	875	56	0.65	0.99	2.5	1.5	1.5	1.6	0.00045	7.4
		40 %	0.25	2.7	875	56	0.65	0.99	2.5	1.5	1.5	1.6		
		60 %	0.23	2.5	890	57.0	0.62	0.94	2.6	1.6	1.6	1.8		
		80 %	0.18	1.9	925	58.0	0.51	0.88	2.8	1.6	1.6	2.1		
K21R 71 G6	K20R 63 G6	25 %	0.30	3.3	875	59	0.60	1.23	2.6	1.6	1.6	1.8	0.00060	8.3
		40 %	0.30	3.3	875	59	0.60	1.23	2.6	1.6	1.6	1.8		
		60 %	0.28	3.0	880	58.0	0.59	1.18	2.8	1.7	1.7	1.9		
		80 %	0.25	2.6	915	60.0	0.55	1.10	2.9	2.0	2.0	2.2		
K21R 80 K6	K20R 71 K6	25 %	0.45	4.8	900	64	0.76	1.34	3.1	1.3	1.3	1.6	0.00130	11.0
		40 %	0.45	4.8	900	64	0.76	1.34	3.1	1.3	1.3	1.6		
		60 %	0.42	4.4	905	64.0	0.74	1.28	3.3	1.4	1.4	1.7		
		80 %	0.37	3.9	915	66.0	0.66	1.22	3.4	2.0	2.0	2.0		
K21R 80 G6	K20R 71 G6	25 %	0.65	6.9	900	65	0.75	1.93	3.2	1.5	1.5	1.8	0.00175	12.5
		40 %	0.65	6.9	900	65	0.75	1.93	3.2	1.5	1.5	1.8		
		60 %	0.60	6.3	905	65.0	0.72	1.85	3.4	1.6	1.6	2.0		
		80 %	0.55	5.7	915	68.0	0.67	1.73	3.7	2.2	2.2	2.4		
K21R 90 S6	K20R 80 K6	25 %	1.00	10.4	915	67.5	0.72	2.97	3.5	1.4	1.4	1.9	0.00325	16.0
		40 %	1.00	10.4	915	67.5	0.72	2.97	3.5	1.4	1.4	1.9		
		60 %	0.90	9.3	925	68.0	0.69	2.75	3.8	1.6	1.6	2.1		
		80 %	0.75	7.7	935	70.0	0.64	2.43	4.5	2.4	2.4	2.6		
K21R 90 L6	K20R 80 G6	25 %	1.5	15.9	900	69	0.76	4.15	3.4	1.5	1.5	1.7	0.00425	19.0
		40 %	1.5	15.9	900	69	0.76	4.15	3.4	1.5	1.5	1.7		
		60 %	1.4	14.8	905	68.0	0.75	3.95	3.6	1.6	1.6	1.8		
		80 %	1.1	11.2	935	73.0	0.69	3.15	4.6	2.2	2.2	2.6		
K21R 100 L6	K20R 90 L6	25 %	2	20.9	915	72	0.77	5.20	3.6	1.3	1.3	1.6	0.00625	24.0
		40 %	2	20.9	915	72	0.77	5.20	3.6	1.3	1.3	1.6		
		60 %	1.8	18.6	925	74.0	0.74	4.75	3.9	1.5	1.5	1.8		
		80 %	1.5	15.2	945	76.4	0.73	3.90	4.6	2.1	2.0	2.4		
K21R 112 M6	K20R 100 L6	25 %	3	31.1	920	76	0.84	6.80	4.2	1.5	1.5	1.9	0.01225	33.5
		40 %	3	31.1	920	76	0.84	6.80	4.2	1.5	1.5	1.9		
		60 %	2.8	28.9	925	77.0	0.83	6.35	4.5	1.6	1.6	2.0		
		80 %	2.2	22.1	950	79.8	0.74	5.35	5.3	2.2	2.1	2.7		
K21R 132 S6	K20R 112 M6	25 %	5.0	53	908	71.0	0.87	11.5	3.3	1.1	1.0	1.6	0.0180	46
		40 %	5.0	53	908	71.0	0.87	11.5	3.3	1.1	1.0	1.6		
		60 %	4.6	48	915	73.0	0.86	10.5	3.6	1.3	1.1	1.8		
		80 %	3.5	35	943	78.0	0.82	8	4.7	1.7	1.5	2.4		
K21R 132 M6	K20R 112 MX6	25 %	7.0	73	912	72.0	0.86	16.5	3.3	1.3	1.1	1.6	0.0230	53
		40 %	7.0	73	912	72.0	0.86	16.5	3.3	1.3	1.1	1.6		
		60 %	6.2	65	916	76.0	0.86	13.5	4.0	1.4	1.2	1.9		
		80 %	4.7	48	941	79.0	0.82	10.5	5.1	1.9	1.7	2.5		
K21R 132 MX6	K20R 132 S6	25 %	8.0	82	930	77.0	0.85	17.5	3.3	1.3	1.1	1.6	0.0430	70
		40 %	8.0	82	930	77.0	0.85	17.5	3.3	1.3	1.1	1.6		
		60 %	7.3	74	938	79.0	0.85	15.5	3.7	1.4	1.3	1.8		
		80 %	6.5	66	947	81.0	0.84	13.5	4.3	1.6	1.4	2.0		
K21R 160 M6	K20R 132 M6	25 %	12.0	123	932	77.0	0.84	27	3.2	1.2	1.0	1.5	0.0530	86
		40 %	12.0	123	932	77.0	0.84	27	3.2	1.2	1.0	1.5		
		60 %	10.5	106	944	81.0	0.84	22.5	3.8	1.4	1.1	1.8		
		80 %	8.8	88	953	82.0	0.84	18.5	4.6	1.7	1.4	2.1		
K21R 160 L6	K20R 160 S6	25 %	16.0	163	939	85.0	0.88	31	3.5	1.3	1.1	1.5	0.1130	114
		40 %	16.0	163	939	85.0	0.88	31	3.5	1.3	1.1	1.5		
		60 %	14.0	141	949	85.0	0.87	27.5	4.0	1.5	1.3	1.8		

Three-phase motors with squirrel-cage rotor

with surface cooling, duty type S6, continuous operation with periodic duty 25 %/40 %/60 %/80 % for rated voltage, thermal class 155 (F), degree of protection IP 55, 50 Hz
Efficiency determination according to IEC/EN 60034-2

Motor selection data													Design point 400 V, 50 Hz	
Type	c.d.f.	P _B	M _B	n _B	η(100%)	cosφ _B	I _B	I _A /I _B	M _A /M _B	M _S /M _B	M _K /M _B	J	m	
	S6						400 V							
		kW	Nm	rpm	%	-	A	-	-	-	-	kgm ²	kg	
Synchronous speed 1000 rpm – 6-pole version														
K21R 180 L6	K20R 160 M6	80 %	12.5	125	955	85.0	0.87	24.5	4.5	1.7	1.5	2.0	0.1450	136
		25 %	24.0	244	940	85.0	0.83	49	3.4	1.5	1.3	1.6		
		40 %	24.0	244	940	85.0	0.83	49	3.4	1.5	1.3	1.6		
		60 %	22.5	227	945	85.0	0.83	46	3.6	1.6	1.4	1.8		
K21R 200 L6	K20R 180 S6	80 %	17.5	174	960	85.0	0.82	36	4.7	2.0	1.9	2.3	0.2280	175
		25 %	26.0	263	944	86.0	0.88	49.5	3.9	1.4	1.2	1.7		
		40 %	26.0	263	944	86.0	0.88	49.5	3.9	1.4	1.2	1.7		
		60 %	24.5	246	952	86.0	0.88	46.5	4.2	1.5	1.3	1.8		
K21R 200 LX6	K20R 180 M6	80 %	21.0	209	960	87.0	0.87	40	4.9	1.8	1.5	2.1	0.2680	200
		25 %	35.0	354	943	87.0	0.86	67.5	3.6	1.3	1.1	1.6		
		40 %	35.0	354	943	87.0	0.86	67.5	3.6	1.3	1.1	1.6		
		60 %	33.0	333	947	87.0	0.86	63.5	3.9	1.4	1.2	1.8		
K21R 225 M6	K20R 200 M6	80 %	25.0	248	962	88.0	0.86	47.5	5.2	1.8	1.6	2.4	0.4430	265
		25 %	45.0	452	950	89.0	0.88	83	4.0	1.4	1.1	1.6		
		40 %	45.0	452	950	89.0	0.88	83	4.0	1.4	1.1	1.6		
		60 %	41.5	415	955	89.0	0.88	76.5	4.3	1.6	1.2	1.8		
K21R 250 M6	K20R 225 M6	80 %	35.0	347	964	89.0	0.88	64.5	5.1	1.9	1.4	2.1	0.8250	360
		25 %	50.0	497	960	88.0	0.86	95.5	4.1	1.5	1.1	1.7		
		40 %	50.0	497	960	88.0	0.86	95.5	4.1	1.5	1.1	1.7		
		60 %	47.0	466	963	89.0	0.87	87.5	4.5	1.6	1.2	1.8		
K21R 280 S6	K20R 250 S6	80 %	43.5	430	966	90.0	0.89	78.5	5.0	1.7	1.3	1.9	1.28	465
		25 %	55.0	539	975	90.0	0.86	103	4.7	1.6	1.2	1.6		
		40 %	55.0	539	975	90.0	0.86	103	4.7	1.6	1.2	1.6		
		60 %	55.0	539	975	90.0	0.86	103	4.7	1.6	1.2	1.6		
K21R 280 M6	K20R 250 M6	80 %	52.0	508	978	91.0	0.86	96	5.1	1.7	1.3	1.7	1.48	520
		25 %	72.0	705	975	90.0	0.85	136	4.3	1.6	1.2	1.7		
		40 %	72.0	705	975	90.0	0.85	136	4.3	1.6	1.2	1.7		
		60 %	67.0	654	978	92.0	0.87	121	4.8	1.7	1.3	1.8		
K21R 315 S6	K20R 280 S6	80 %	64.0	624	979	92.0	0.87	115	5.1	1.8	1.4	1.9	2.63	690
		25 %	110	1072	980	92.5	0.86	200	4.3	1.4	1.2	1.6		
		40 %	110	1072	980	92.5	0.86	200	4.3	1.4	1.2	1.6		
		60 %	100	973	982	93.0	0.86	180	4.8	1.5	1.3	1.8		
K21R 315 M6	K20R 280 M6	80 %	88	853	985	93.0	0.87	157	5.5	1.7	1.4	2.0	3.33	800
		25 %	130	1267	980	93.0	0.86	235	4.3	1.4	1.2	1.6		
		40 %	130	1267	980	93.0	0.86	235	4.3	1.4	1.2	1.6		
		60 %	120	1166	983	93.0	0.86	217	4.7	1.5	1.3	1.8		
K21R 315 MX6	K20R 315 S6	80 %	105	1018	985	94.0	0.87	185	5.5	1.7	1.4	2.0	3.60	880
		25 %	165	1611	978	93.0	0.86	298	4.5	1.5	1.3	1.7		
		40 %	165	1611	978	93.0	0.86	298	4.5	1.5	1.3	1.7		
		60 %	155	1510	980	93.0	0.86	280	4.8	1.6	1.3	1.8		
K21R 315 MY6	K20R 315 M6	80 %	125	1214	983	93.8	0.87	221	6.1	2.0	1.7	2.3	6.00	1050
		25 %	200	1953	978	94.5	0.88	347	4.6	1.6	1.3	1.7		
		40 %	200	1953	978	94.5	0.88	347	4.6	1.6	1.3	1.7		
		60 %	190	1852	980	94.5	0.88	330	4.8	1.7	1.4	1.8		
K21R 315 L6	K20R 315 L6	80 %	155	1503	985	94.5	0.88	269	5.9	2.0	1.7	2.2	6.67	1250
		25 %	220	2148	978	94.5	0.88	382	5.4	1.7	1.4	1.7		
		40 %	220	2148	978	94.5	0.88	382	5.4	1.7	1.4	1.7		
		60 %	210	2046	980	94.5	0.88	364	5.7	1.7	1.4	1.8		
K21R 315 LX6	K20R 315 LX6	80 %	185	1794	985	94.5	0.88	321	6.4	2.0	1.6	2.1	8.6	1460
		25 %	270	2637	978	94.0	0.85	488	5.9	1.6	1.5	2.0		
		40 %	270	2637	978	94.0	0.85	488	5.9	1.6	1.5	2.0		
		60 %	250	2431	982	94.5	0.86	444	6.5	1.7	1.6	2.1		
		80 %	235	2269	989	95.0	0.86	415	7.0	1.9	1.7	2.3		

Three-phase motors with squirrel-cage rotor

with surface cooling, duty type S6, continuous operation with periodic duty 25 %/40 %/60 %/80 % for rated voltage, thermal class 155 (F), degree of protection IP 55, 50 Hz
 Efficiency determination according to IEC/EN 60034-2

Motor selection data												Design point 400 V, 50 Hz		
Type		c.d.f. S6	P _B kW	M _B Nm	n _B rpm	η(100%) %	cosφ _B -	I _B 400 V A	I _x /I _B -	M _x /M _B -	M _G /M _B -	M _K /M _B -	J kgm ²	m kg
Synchronous speed 750 rpm – 8-pole version														
K21R 71 K8	K20R 63 K8	25 %	0.105	1.5	655	45	0.58	0.58	2.0	1.5	1.5	1.8	0.00050	6.6
		40 %	0.105	1.5	655	45	0.58	0.58	2.0	1.5	1.5	1.8		
		60 %	0.10	1.4	665	44.0	0.58	0.57	2.1	1.6	1.6	1.8		
		80 %	0.09	1.3	675	45.5	0.51	0.56	2.1	1.9	1.9	2.1		
K21R 71 G8	K20R 63 G8	25 %	0.14	2.0	655	47	0.57	0.75	2.1	1.4	1.4	1.8	0.00060	8.1
		40 %	0.14	2.0	655	47	0.57	0.75	2.1	1.4	1.4	1.8		
		60 %	0.13	1.9	665	46.0	0.56	0.74	2.1	1.5	1.5	1.9		
		80 %	0.12	1.7	670	46.5	0.51	0.73	2.3	1.8	1.8	2.1		
K21R 80 K8	K20R 71 K8	25 %	0.22	3.1	670	56	0.68	0.83	2.4	1.3	1.3	1.6	0.00130	10.5
		40 %	0.22	3.1	670	56	0.68	0.83	2.4	1.3	1.3	1.6		
		60 %	0.21	3.0	675	56.0	0.67	0.81	2.5	1.4	1.4	1.7		
		80 %	0.18	2.5	690	56.5	0.59	0.78	2.8	2.0	2.0	2.2		
K21R 80 G8	K20R 71 G8	25 %	0.35	5.1	655	57	0.68	1.30	2.6	1.4	1.4	1.5	0.00175	12.0
		40 %	0.35	5.1	655	57	0.68	1.30	2.6	1.4	1.4	1.5		
		60 %	0.33	4.8	660	56.0	0.68	1.24	2.7	1.5	1.5	1.7		
		80 %	0.25	3.4	695	58.0	0.56	1.12	3.0	2.3	2.3	2.5		
K21R 90 S8	K20R 80 K8	25 %	0.50	7.0	680	59	0.65	1.87	2.6	1.3	1.3	1.6	0.00300	15.0
		40 %	0.50	7.0	680	59	0.65	1.87	2.6	1.3	1.3	1.6		
		60 %	0.45	6.2	690	60.0	0.62	1.75	2.8	1.4	1.4	1.8		
		80 %	0.37	5.1	700	61.5	0.54	1.6	3.0	1.9	1.9	2.1		
K21R 90 L8	K20R 80 G8	25 %	0.70	9.8	680	64	0.64	2.48	2.8	1.4	1.4	1.7	0.00375	18.0
		40 %	0.70	9.8	680	64	0.64	2.48	2.8	1.4	1.4	1.7		
		60 %	0.65	9.1	685	64.0	0.62	2.37	2.9	1.5	1.5	1.8		
		80 %	0.55	7.6	695	64.5	0.60	2.04	3.2	1.9	1.9	2.2		
K21R 100 L8	K20R 90 L8	25 %	0.95	13.2	690	64	0.65	3.30	2.8	1.3	1.3	1.6	0.00625	23.0
		40 %	0.95	13.2	690	64	0.65	3.30	2.8	1.3	1.3	1.6		
		60 %	0.90	12.4	695	64.0	0.64	3.15	2.9	1.4	1.4	1.7		
		80 %	0.75	10.2	705	67.0	0.60	2.7	3.3	2.0	2.0	2.3		
K21R 100 LX8	K20R 100 S8	25 %	1.5	21.1	680	70	0.76	4.05	3.2	1.4	1.4	1.6	0.00900	28.0
		40 %	1.5	21.1	680	70	0.76	4.05	3.2	1.4	1.4	1.6		
		60 %	1.4	19.5	685	71.0	0.74	3.85	3.4	1.5	1.5	1.8		
		80 %	1.1	14.9	705	73.0	0.67	3.25	4.0	2.0	2.0	2.4		
K21R 112 M8	K20R 100 L8	25 %	2	28	685	72	0.77	5.20	3.3	1.5	1.5	1.7	0.01225	33.5
		40 %	2	28	685	72	0.77	5.20	3.3	1.5	1.5	1.7		
		60 %	1.8	25	690	74.0	0.75	4.68	3.7	1.7	1.7	1.9		
		80 %	1.5	20	705	75.5	0.70	4.1	4.4	2.2	2.1	2.5		
K21R 132 S8	K20R 112 M8	25 %	2.8	39	694	72.6	0.79	7		1.3	1.2	1.8	0.01800	46
		40 %	2.8	39	694	72.6	0.79	7		1.3	1.2	1.8		
		60 %	2.8	39	694	72.6	0.79	7	3.2	1.3	1.2	1.8		
		80 %	2.6	36	699	73.5	0.77	6.6	3.4	1.4	1.3	1.9		
K21R 132 M8	K20R 112 MX8	25 %	3.8	37	986	73.6	0.80	9.3	3.2	1.3	1.2	1.8	0.0230	53
		40 %	3.8	53	686	73.6	0.80	9.3	3.2	1.3	1.2	1.8		
		60 %	3.8	53	686	73.6	0.80	9.3	3.2	1.3	1.2	1.8		
		80 %	3.5	48	692	75.0	0.77	8.7	3.4	1.4	1.4	1.9		
K21R 160 M8	K20R 132 S8	25 %	4.2	57	704	77.0	0.78	10	3.8	1.5	1.3	1.8	0.0430	70
		40 %	4.2	57	704	77.0	0.78	10	3.8	1.5	1.3	1.8		
		60 %	4.2	57	704	77.0	0.78	10	3.8	1.5	1.3	1.8		
		80 %	4.2	57	704	77.0	0.78	10	3.8	1.5	1.3	1.8		
K21R 160 MX8	K20R 132 M8	25 %	6.4	86	707	79.0	0.78	15	3.5	1.5	1.4	1.8	0.0530	86
		40 %	6.4	86	707	79.0	0.78	15	3.5	1.5	1.4	1.8		
		60 %	6.4	86	707	79.0	0.78	15	3.5	1.5	1.4	1.8		
		80 %	6.4	86	707	79.0	0.78	15	3.5	1.5	1.4	1.8		
K21R 160 L8	K20R 160 S8	25 %	8.8	117	720	81.0	0.78	20	3.7	1.5	1.4	1.8	0.1130	114
		40 %	8.8	117	720	81.0	0.78	20	3.7	1.5	1.4	1.8		
		60 %	8.8	117	720	81.0	0.78	20	3.7	1.5	1.4	1.8		
		80 %	8.8	117	720	81.0	0.78	20	3.7	1.5	1.4	1.8		
K21R 180 L8	K20R 160 M8	25 %	12.8	171	714	84.0	0.79	28	3.9	1.7	1.4	1.8	0.1450	136
		40 %	12.8	171	714	84.0	0.79	28	3.9	1.7	1.4	1.8		
		60 %	12.8	171	714	84.0	0.79	28	3.9	1.7	1.4	1.8		

Three-phase motors with squirrel-cage rotor

with surface cooling, duty type S6, continuous operation with periodic duty 25 %/40 %/60 %/80 %
for rated voltage, thermal class 155 (F), degree of protection IP 55, 50 Hz
Efficiency determination according to IEC/EN 60034-2

Motor selection data												Design point 400 V, 50 Hz		
Type	c.d.f.	P _B	M _B	n _B	η(100%)	cosφ _B	I _B	I _A /I _B	M _A /M _B	M _S /M _B	M _K /M _B	J	m	
	S6						400 V							
		kW	Nm	rpm	%	-	A	-	-	-	-	kgm ²	kg	
Synchronous speed 750 rpm – 8-pole version														
K21R 200 L8	K20R 180 S8	80 %	12.8	171	714	84.0	0.79	28	3.9	1.7	1.4	1.8	0.228	175
		25 %	19.2	257	714	84.0	0.80	41	4.0	1.5	1.3	1.8		
		40 %	19.2	257	714	84.0	0.80	41	4.0	1.5	1.3	1.8		
		60 %	19.2	257	714	84.0	0.80	41	4.0	1.5	1.3	1.8		
K21R 200 L8	K20R 180 M8	80 %	17.6	233	720	85.0	0.78	38.5	4.2	1.7	1.4	1.9	0.268	200
		25 %	23.5	316	711	86.0	0.82	48	4.0	1.6	1.3	1.7		
		40 %	23.5	316	711	86.0	0.82	48	4.0	1.6	1.3	1.7		
		60 %	23.5	316	711	86.0	0.82	48	4.0	1.6	1.3	1.7		
K21R 225 S8		80 %	21.5	287	716	86.0	0.82	44	4.3	1.7	1.5	1.9	0.440	265
		25 %	22.5	297	724	87.5	0.83	44.5	4.3	1.6	1.3	1.8		
		40 %	22.5	297	724	87.5	0.83	44.5	4.3	1.6	1.3	1.8		
		60 %	22.5	297	724	87.5	0.83	44.5	4.3	1.6	1.3	1.8		
K21R 225 M8	K20R 200 M8	80 %	21.5	283	726	88.0	0.82	43	4.4	1.7	1.4	1.9	0.440	265
		25 %	28.0	373	716	87.5	0.84	55	4.0	1.4	1.2	1.7		
		40 %	28.0	373	716	87.5	0.84	55	4.0	1.4	1.2	1.7		
		60 %	28.0	373	716	87.5	0.84	55	4.0	1.4	1.2	1.7		
K21R 250 M8	K20R 225 M8	80 %	25.5	338	720	88.5	0.84	49.5	4.5	1.5	1.3	1.9	0.825	360
		25 %	36.5	479	727	89.0	0.80	74	4.5	1.8	1.5	1.8		
		40 %	36.5	479	727	89.0	0.80	74	4.5	1.8	1.5	1.8		
		60 %	36.5	479	727	89.0	0.80	74	4.5	1.8	1.5	1.8		
K21R 280 S8	K20R 250 S8	80 %	35.0	459	728	90.0	0.80	70	4.7	1.9	1.5	1.9	1.35	465
		25 %	45.0	588	731	90.0	0.80	90	4.5	1.6	1.2	1.6		
		40 %	45.0	588	731	90.0	0.80	90	4.5	1.6	1.2	1.6		
		60 %	45.0	588	731	90.0	0.80	90	4.5	1.6	1.2	1.6		
K21R 280 M8	K20R 250 M8	80 %	41.0	535	732	90.0	0.80	82	4.9	1.8	1.3	1.8	1.55	520
		25 %	55.0	717	733	91.0	0.79	110	4.6	1.8	1.2	1.6		
		40 %	55.0	717	733	91.0	0.79	110	4.6	1.8	1.2	1.6		
		60 %	55.0	717	733	91.0	0.79	110	4.6	1.8	1.2	1.6		
K21R 315 S8	K20R 280 S8	80 %	50.0	651	734	91.0	0.78	102	5.0	2.0	1.3	1.8	2.63	690
		25 %	73.0	946	737	92.0	0.79	145	4.4	1.5	1.2	1.8		
		40 %	73.0	946	737	92.0	0.79	145	4.4	1.5	1.2	1.8		
		60 %	73.0	946	737	92.0	0.79	145	4.4	1.5	1.2	1.8		
K21R 315 M8	K20R 280 M8	80 %	73.0	946	737	92.0	0.79	145	4.4	1.5	1.2	1.8	3.33	800
		25 %	100	1319	724	92.0	0.79	199	4.3	1.5	1.2	1.7		
		40 %	100	1319	724	92.0	0.79	199	4.3	1.5	1.2	1.7		
		60 %	100	1319	724	92.0	0.79	199	4.3	1.5	1.2	1.7		
K21R 315 MX8	K20R 315 S8	80 %	95	1250	726	92.0	0.81	184	4.7	1.5	1.2	1.8	3.60	880
		25 %	110	1429	735	93.0	0.81	211	4.9	1.6	1.4	2.0		
		40 %	110	1429	735	93.0	0.81	211	4.9	1.6	1.4	2.0		
		60 %	110	1429	735	93.0	0.81	211	4.9	1.6	1.4	2.0		
K21R 315 MY8	K20R 315 M8	80 %	110	1429	735	93.0	0.81	211	4.9	1.6	1.4	2.0	6.00	1050
		25 %	160	2076	736	92.0	0.80	314	4.0	1.6	1.4	1.8		
		40 %	160	2076	736	92.0	0.80	314	4.0	1.6	1.4	1.8		
		60 %	160	2076	736	92.0	0.80	314	4.0	1.6	1.4	1.8		
K21R 315 L8	K20R 315 L8	80 %	150	1944	737	93.0	0.80	291	4.3	1.8	1.5	1.9	6.76	1250
		25 %	165	2138	737	94.0	0.82	309	5.0	1.6	1.4	1.7		
		40 %	165	2138	737	94.0	0.82	309	5.0	1.6	1.4	1.7		
		60 %	165	2138	737	94.0	0.82	309	5.0	1.6	1.4	1.7		
K21R 315 LX8	K20R 315 LX8	80 %	155	2008	737	94.5	0.82	289	5.3	1.7	1.4	1.8	8.71	1430
		25 %	210	2736	733	93.0	0.77	423	5.2	1.7	1.4	1.9		
		40 %	210	2736	733	93.0	0.77	423	5.2	1.7	1.4	1.9		
		60 %	200	2602	734	94.0	0.77	399	5.5	1.7	1.5	2.0		
		80 %	180	2339	735	95.0	0.78	351	6.3	1.9	1.7	2.2		

Three-phase motors with squirrel-cage rotor

Pole-changing, for constant load torque
with Δ-YY-Dahlander winding
with surface cooling, duty type S1, continuous duty
Thermal class 155, degree of protection IP 55

Motor selection data													Design point 400 V, 50 Hz		
Type			P_B	M_B	n_B	η_B	$\cos\phi_B$	I_B	I_A/I_B	M_A/M_B	M_S/M_B	M_K/M_B	J	m	
			kW	Nm	rpm	%	-	A	-	-	-	-	kgm ²	kg	
Synchronous speed 1500/3000 rpm – 4- to 2-pole version															
K21R	63 G	K20R	56 G	0.12	0.82	1405	53.0	0.65	0.55	3.0	1.9	1.9	2.5	0.00024	5.2
	4-2		4-2	0.18	0.61	2840	63.0	0.82	0.50	4.2	2.0	1.8	2.2		4.8 ¹⁾
K21R	71 K	K20R	63 K	0.17	1.16	1405	58.5	0.69	0.61	3.3	1.3	1.3	2.1	0.00040	6.8
	4-2		4-2	0.23	0.77	2840	63.5	0.82	0.64	4.3	1.5	1.5	2.0		6.3 ¹⁾
K21R	71 G	K20R	63 G	0.30	2.06	1390	60.0	0.73	1.00	3.5	1.5	1.5	2.0	0.00050	7.8
	4-2		4-2	0.45	1.55	2770	62.0	0.88	1.20	3.8	1.1	1.1	1.6		7.1 ¹⁾
K21R	80 K	K20R	71 K	0.48	3.29	1395	67.0	0.77	1.35	4.1	1.5	1.5	2.0	0.00087	10.6
	4-2		4-2	0.55	1.84	2855	66.0	0.86	1.40	5.1	1.3	1.3	2.1		9.9 ¹⁾
K21R	80 G	K20R	71 G	0.70	4.78	1400	67.5	0.75	2.00	3.7	1.6	1.6	1.8	0.00107	11.7
	4-2		4-2	0.85	2.84	2860	68.0	0.84	2.15	4.9	1.4	1.4	1.7		11.0 ¹⁾
K21R	90 S	K20R	80 K	1.10	7.45	1410	73.0	0.80	2.71	4.7	1.4	1.4	1.9	0.00207	15.5
	4-2		4-2	1.40	4.70	2845	70.0	0.90	3.20	5.5	1.5	1.5	1.7		14.5 ¹⁾
K21R	90 L	K20R	80 G	1.40	9.48	1410	73.5	0.80	3.45	4.6	1.5	1.5	2.1	0.00260	18.0
	4-2		4-2	1.80	6.02	2855	70.0	0.90	4.15	5.6	1.7	1.7	1.9		17.0 ¹⁾
K21R	100 L	K20R	90 L	2.00	13.6	1405	76.0	0.85	4.50	5.1	1.5	1.5	2.1	0.00400	23.5
	4-2		4-2	2.40	8.00	2865	74.0	0.91	5.10	5.8	1.4	1.4	2.0		22.5 ¹⁾
K21R	100 LX	K20R	100 S	2.60	17.2	1440	80.0	0.80	5.85	6.1	1.7	1.7	2.5	0.00725	30.0
	4-2		4-2	3.10	10.2	2900	76.0	0.87	6.80	7.3	1.6	1.6	2.6		30.0 ¹⁾
K21R	112 M	K20R	100 L	3.70	24.8	1425	80.0	0.86	7.80	5.7	1.5	1.5	2.3	0.00900	37.0
	4-2		4-2	4.40	14.5	2890	77.5	0.90	9.10	7.0	1.6	1.6	2.4		36.0 ¹⁾
K21R	132 S	K20R	112 M	4.2	28.1	1430	83.0	0.87	8.4	6.3	1.7	1.5	2.4	0.015	50
	4-2		4-2	5.3	17.6	2870	80.0	0.92	10.5	6.5	2.1	1.3	2.6		
K21R	132 M	K20R	132 S	5.3	34.9	1450	86.0	0.84	10.5	5.3	1.7	1.4	2.2	0.028	69
	4-2		4-2	6.5	21.3	2910	81.0	0.90	13	6.2	2.0	2.0	2.4		
K21R	160 M	K20R	132 M	7.6	50.2	1445	86.0	0.86	15	5.4	1.7	1.3	2.2	0.035	86
	4-2		4-2	9.5	31.3	2900	83.0	0.92	18	6.5	1.9	1.0	2.4		
K21R	160 L	K20R	160 S	10.5	68.7	1460	88.5	0.88	19.5	5.8	1.7	1.0	2.0	0.078	120
	4-2		4-2	13.0	42.6	2915	86.0	0.91	24	6.2	1.8	0.8	1.9		
K21R	180 M	K20R	160 M	12.5	81.8	1460	89.0	0.89	23	6.1	2.0	1.4	2.3	0.090	136
	4-2		4-2	16.0	52.3	2920	86.0	0.92	29	6.7	1.9	0.8	2.2		
K21R	180 L	K20R	180 S	15.5	101	1470	90.0	0.89	28	6.0	1.4	1.1	2.2	0.138	170
	4-2		4-2	18.5	60.3	2930	89.0	0.93	32.5	7.2	1.4	0.6	2.1		
K21R	200 L	K20R	180 M	21.0	137	1465	91.0	0.89	37.5	6.0	1.5	1.1	2.1	0.168	220
	4-2		4-2	25.0	81.2	2940	90.0	0.93	43	7.4	1.7	0.7	2.3		
K21R	225 S	K20R	200 M	25.0	162	1470	92.3	0.87	45	6.6	1.8	1.4	2.4	0.275	270
	4-2		4-2	31.0	101	2940	90.0	0.91	54.5	7.2	1.6	0.8	2.2		
K21R	225 M	K20R	200 L	30.0	194	1475	92.3	0.87	54	7.0	1.8	1.4	2.4	0.313	300
	4-2		4-2	37.0	120	2945	90.0	0.91	65	8.0	1.7	0.7	2.5		
K21R	250 M	K20R	225 M	37.0	240	1475	92.5	0.86	67	6.9	1.7	1.3	2.1	0.525	375
	4-2		4-2	45.0	145	2955	87.0	0.91	82	7.8	1.7	0.5	2.1		
K21R	280 S	K20R	250 S	48.0	310	1480	93.2	0.84	88.5	7.5	1.6	1.4	2.3	0.950	520
	4-2		4-2	60.0	193	2965	89.5	0.91	106	8.1	1.3	0.8	2.5		
K21R	280 M	K20R	250 M	60.0	387	1480	93.5	0.85	109	6.9	1.6	1.4	2.1	1.11	580
	4-2		4-2	70.0	225	2965	90.0	0.92	122	8.2	1.2	0.8	2.2		
K21R	315 S	K20R	280 S	75.0	482	1485	94.5	0.84	136	6.9	1.6	1.4	2.2	1.96	740
	4-2		4-2	90.0	289	2975	93.0	0.92	152	8.0	1.7	1.2	2.8		
K21R	315 M	K20R	280 M	95.0	611	1485	95.0	0.85	170	7.8	1.7	1.6	2.3	2.27	840
	4-2		4-2	115	370	2970	93.0	0.91	196	8.5	1.8	1.0	3.2		
K21R	315 MX	K20R	315 S	110	707	1485	95.0	0.85	197	8.0	1.7	1.5	2.3	2.73	1000
	4-2		4-2	132	424	2970	93.5	0.91	224	8.5	1.8	1.0	2.9		
K21R	315 MY	K20R	315 M	135	865	1490	95.8	0.86	237	8.0	2.0	1.5	2.8	4.82	1200
	4-2		4-2	165	529	2980	94.8	0.92	273	8.5	2.1	1.1	2.9		
K21R	315 L	K20R	315 L	145	929	1490	95.7	0.87	251	8.0	1.7	1.2	2.3	5.93	1450
	4-2		4-2	190	609	2980	93.8	0.93	314	9.8	1.5	1.1	2.7		
K21R	315 LX	K20R	315 LX	160	1025	1490	95.6	0.87	278	8.5	1.7	1.4	2.4	6.82	1630
	4-2		4-2	220	705	2980	93.2	0.94	362	10.0	2.0	1.0	2.4		

¹⁾ Weights for K20R

Three-phase motors with squirrel-cage rotor

Pole-changing, enhanced output, for constant load torque
with Δ -YY-Dahlander winding
with surface cooling, duty type S1, continuous duty
Thermal class 155, degree of protection IP 55

Motor selection data													Design point 400 V, 50 Hz						
Type				P_B	M_B	n_B	η_B	$\cos\phi_B$	I_B	I_A/I_B	M_A/M_B	M_S/M_B	M_K/M_B	J	m				
									400 V										
									kW	Nm	rpm	%	-	A	-	-	-	kgm ²	kg
Synchronous speed 1500/3000 rpm – 4- to 2-pole version																			
K21R	132 S	K20R	112 M	4.9	32.6	1435	83.0	0.85	10	6.3	1.8	1.5	2.4	0.015	50				
	4-2		4-2	5.9	19.5	2890	79.0	0.89	12	6.5	1.8	1.3	2.5						
K21R	132 M	K20R	132 S	6.8	45.1	1440	86.0	0.83	14	4.9	1.6	1.3	2.0	0.028	69				
	4-2		4-2	8.0	26.4	2895	81.0	0.88	16	5.4	1.9	1.3	2.2						
K21R	160 M	K20R	132 M	9.5	63.0	1440	87.0	0.84	19	5.4	1.7	1.3	2.2	0.035	86				
	4-2		4-2	11.0	36.2	2900	81.0	0.87	22.5	6.3	2.0	1.1	2.4						
K21R	160 L	K20R	160 S	12.5	81.8	1460	88.5	0.87	23.5	5.8	1.7	1.3	2.0	0.078	120				
	4-2		4-2	15.0	49.1	2915	85.0	0.86	29.5	6.0	1.8	1.0	1.9						
K21R	180 M	K20R	160 M	15.0	98.1	1460	89.0	0.87	28	6.1	2.1	1.4	2.3	0.090	136				
	4-2		4-2	19.0	62.1	2920	85.0	0.87	37	6.2	1.9	0.9	2.2						
K21R	180 L	K20R	180 S	18.5	121	1465	90.0	0.85	35	6.2	1.6	1.2	2.2	0.138	170				
	4-2		4-2	22.0	71.6	2935	88.0	0.89	40.5	7.0	1.5	0.7	2.2						
K21R	200 L	K20R	180 M	25.0	162	1470	91.0	0.85	46.5	7.0	2.0	1.5	2.4	0.168	220				
	4-2		4-2	30.0	97.2	2950	88.0	0.89	55.5	7.4	1.8	0.9	2.4						
K21R	225 S	K20R	200 M	30.0	195	1470	92.0	0.85	55.5	6.6	1.8	1.3	2.3	0.275	270				
	4-2		4-2	35.0	114	2945	90.0	0.89	63	7.2	1.6	0.8	2.2						
K21R	225 M	K20R	200 L	36.0	235	1460	91.5	0.85	67	7.0	1.8	1.4	2.4	0.313	300				
	4-2		4-2	43.0	140	2940	90.0	0.90	76.5	7.6	1.7	0.7	2.5						
K21R	250 M	K20R	225 M	47.0	304	1475	93.0	0.84	87	7.0	1.8	1.3	2.0	0.525	375				
	4-2		4-2	54.0	174	2955	90.0	0.88	98.5	7.7	1.7	0.7	2.2						
K21R	280 S	K20R	250 S	60.0	386	1485	94.5	0.86	107	7.0	1.5	1.3	2.4	0.950	520				
	4-2		4-2	72.0	232	2965	92.5	0.89	126	8.1	1.4	0.8	2.6						
K21R	280 M	K20R	250 M	75.0	484	1480	94.5	0.86	133	7.2	1.8	1.4	2.2	1.11	580				
	4-2		4-2	85.0	274	2960	92.0	0.90	148	8.2	1.4	0.8	2.4						
K21R	315 S	K20R	280 S	85.0	547	1485	94.5	0.84	155	8.0	1.9	1.4	2.6	1.96	740				
	4-2		4-2	95.0	305	2975	93.0	0.91	162	9.0	2.0	1.1	3.5						
K21R	315 M	K20R	280 M	95.0	611	1485	94.0	0.85	172	9.0	2.0	1.4	3.0	2.27	840				
	4-2		4-2	115	370	2970	93.0	0.91	196	9.5	2.0	1.1	3.8						
K21R	315 MX	K20R	315 S	110	707	1485	95.0	0.85	197	9.0	1.7	1.5	2.5	2.73	1000				
	4-2		4-2	132	424	2970	93.5	0.91	224	9.5	1.8	1.0	2.9						
K21R	315 MY	K20R	315 M	135	865	1490	95.8	0.85	239	9.0	2.0	1.5	2.8	4.82	1300				
	4-2		4-2	165	529	2980	94.8	0.92	273	10.0	2.1	1.1	2.9						

Three-phase motors with squirrel-cage rotor

Pole-changing, for quadratically increasing load torque
 Fan drives with Y-YY-Dahlander winding
 with surface cooling, duty type S1, continuous duty
 Thermal class 155, degree of protection IP 55

Motor selection data														Design point 400 V, 50 Hz	
Type				P_B	M_B	n_B	η_B	$\cos\phi_B$	I_B	I_A/I_B	M_A/M_B	M_S/M_B	M_K/M_B	J	m
									400 V						
				kW	Nm	rpm	%	-	A	-	-	-	-	kgm ²	kg
Synchronous speed 1500/3000 rpm – 4- to 2-pole version															
K21R	71 K	K20R	63 K	0.08	0.54	1415	59.0	0.70	0.28	3.6	1.3	1.3	1.9	0.00040	6.8
	4-2L		4-2L	0.30	1.01	2830	56.0	0.82	0.95	4.2	1.1	1.1	1.8		6.3 ¹⁾
K21R	71 G	K20R	63 G	0.12	0.82	1405	67.0	0.77	0.34	3.1	1.5	1.5	1.8	0.00050	7.8
	4-2L		4-2L	0.48	1.64	2795	65.0	0.88	1.21	4.2	1.6	1.6	1.9		7.1 ¹⁾
K21R	80 K	K20R	71 K	0.18	1.22	1415	70.0	0.79	0.47	4.4	1.7	1.7	2.0	0.00087	10.6
	4-2L		4-2L	0.70	2.36	2830	66.0	0.88	1.75	5.1	1.8	1.8	2.1		9.9 ¹⁾
K21R	80 G	K20R	71 G	0.25	1.70	1405	73.0	0.79	0.63	4.6	1.5	1.5	2.0	0.00107	11.7
	4-2L		4-2L	0.90	3.03	2840	69.0	0.86	2.19	5.8	2.0	2.0	2.1		11.0 ¹⁾
K21R	90 S	K20R	80 K	0.37	2.45	1440	74.0	0.83	0.87	4.9	1.4	1.4	2.1	0.00207	15.5
	4-2L		4-2L	1.50	5.04	2840	71.0	0.89	3.45	5.0	1.5	1.5	1.7		14.5 ¹⁾
K21R	90 L	K20R	80 G	0.50	3.34	1430	78.0	0.83	1.12	4.6	1.5	1.5	2.2	0.00260	18.0
	4-2L		4-2L	2.00	6.73	2840	73.0	0.89	4.45	5.5	1.5	1.5	1.8		17.0 ¹⁾
K21R	100 L	K20R	90 L	0.70	4.66	1435	78.0	0.84	1.55	5.3	1.5	1.5	2.3	0.00400	23.5
	4-2L		4-2L	2.80	9.35	2860	74.0	0.89	6.10	6.3	1.5	1.5	2.0		22.5 ¹⁾
K21R	100 LX	K20R	100 S	0.90	5.91	1455	80.0	0.82	2.00	6.1	1.5	1.5	2.3	0.00725	30.0
	4-2L		4-2L	3.60	11.9	2890	76.5	0.89	7.70	6.7	1.9	1.9	2.5		30.0 ¹⁾
K21R	112 M	K20R	100 L	1.20	7.96	1440	80.0	0.85	2.50	5.3	1.5	1.5	2.2	0.009	37.0
	4-2L		4-2L	4.80	16.0	2870	74.0	0.92	10.2	7.0	1.5	1.5	2.1		36.0 ¹⁾
K21R	132 S	K20R	112 M	1.5	9.88	1450	82.0	0.88	3	5.2	1.4	1.2	2.2	0.015	50
	4-2L		4-2L	5.5	18.3	2870	78.0	0.92	11	6.0	1.9	1.0	2.5		
K21R	132 M	K20R	132 S	2.2	14.4	1460	82.0	0.87	4.5	5.2	1.4	1.0	1.9	0.028	69
	4-2L		4-2L	8.2	27.0	2900	76.0	0.88	17.5	6.0	2.0	1.1	2.4		
K21R	160 M	K20R	132 M	3.3	21.7	1450	86.0	0.87	6.4	5.0	1.3	1.0	1.8	0.038	86
	4-2L		4-2L	12.0	39.7	2890	83.0	0.88	23.5	6.6	1.8	1.0	2.4		
K21R	160 L	K20R	160 S	4.3	28.2	1460	83.0	0.89	8.4	5.8	1.8	1.1	2.0	0.078	120
	4-2		4-2	17.0	55.7	2915	80.0	0.89	34.5	6.5	1.6	0.8	2.5		
K21R	180 M	K20R	160 M	5.5	35.7	1470	89.0	0.87	10.5	5.8	1.7	1.2	2.2	0.090	136
	4-2L		4-2L	20.0	65.4	2920	82.0	0.86	41	6.5	1.8	1.0	2.5		
K21R	180 L	K20R	180 S	6.4	41.3	1480	88.5	0.89	11.5	6.0	1.5	1.1	2.2	0.138	170
	4-2L		4-2L	24.0	78.1	2935	85.0	0.88	46.5	7.0	2.0	0.9	2.6		
K21R	200 L	K20R	180 M	7.8	50.5	1475	90.0	0.89	14	6.5	1.5	1.2	2.4	0.168	220
	4-2L		4-2L	30.0	97.5	2940	88.0	0.90	54.5	7.5	2.1	1.3	2.8		
K21R	225 S	K20R	200 M	9.5	61.1	1485	89.5	0.88	17.5	7.0	1.8	1.5	2.6	0.275	270
	4-2L		4-2L	37.0	120	2950	86.0	0.86	72	8.0	2.4	1.5	3.0		
K21R	225 M	K20R	200 L	12.0	77.4	1480	92.0	0.88	21.5	6.5	1.4	1.1	2.4	0.313	300
	4-2L		4-2L	45.0	146	2950	88.0	0.88	84	7.5	2.0	1.0	2.6		
K21R	250 M	K20R	225 M	15.0	96.8	1480	90.0	0.85	28.5	6.2	1.5	0.9	1.8	0.525	375
	4-2L		4-2L	55.0	178	2950	88.0	0.88	103	7.5	2.2	0.7	2.4		
K21R	280 S	K20R	250 S	20.0	128	1485	91.5	0.81	39	6.0	1.1	0.9	1.7	0.950	520
	4-2L		4-2L	75.0	242	2965	90.0	0.88	137	8.0	2.0	1.3	2.4		
K21R	280 M	K20R	250 M	24.0	154	1485	92.0	0.82	46	6.1	1.1	0.9	1.7	1.10	580
	4-2L		4-2L	90.0	290	2965	91.0	0.91	157	8.0	2.0	1.3	2.4		
K21R	315 S	K20R	280 S	29.0	186	1490	94.0	0.81	55	6.9	1.1	1.0	1.9	1.96	740
	4-2L		4-2L	110	353	2975	93.0	0.89	192	9.6	1.6	1.2	3.0		
K21R	315 M	K20R	280 M	35.0	225	1488	94.0	0.81	66.5	7.0	1.4	1.2	1.7	2.27	840
	4-2L		4-2L	132	424	2975	92.6	0.90	229	9.6	1.6	0.8	2.6		
K21R	315 MY	K20R	315 M	50.0	320	1490	95.0	0.86	88.5	7.2	1.4	1.0	2.2	4.82	1200
	4-2L		4-2L	160	513	2980	94.5	0.91	269	12.0	2.4	1.2	3.5		

¹⁾ Weights for K20R

Three-phase motors with squirrel-cage rotor

Pole-changing, for quadratically increasing load torque
 Fan drives with two separate windings in Y-Y configuration
 with surface cooling, duty type S1, continuous duty
 Thermal class 155, degree of protection IP 55

Motor selection data												Design point 400 V, 50 Hz											
Type			P_B	M_B	n_B	η_B	$\cos\phi_B$	I_B	I_A/I_B	M_A/M_B	M_S/M_B	M_K/M_B	J	m									
												400 V											
												kW	Nm	rpm	%	-	A	-	-	-	-	kgm ²	kg
Synchronous speed 1000/3000 rpm – 6- to 2-pole version																							
K21R	132 S	K20R	112 M	0.55	5.36	980	65.0	0.61	2	5.2	1.5	2.9	0.015	50									
	6-2L		6-2L	4.5	14.9	2890	82.0	0.89	8.9	6.6	2.2	2.4											
K21R	132 M	K20R	132 S	0.8	7.76	985	69.5	0.64	2.6	4.9	1.4	2.8	0.028	69									
	6-2L		6-2L	7.0	23.6	2830	86.0	0.93	12.5	6.2	1.7	2.2											
K21R	160 M	K20R	132 M	1.2	11.7	982	72.0	0.69	3.5	5.0	1.3	2.5	0.035	86									
	6-2L		6-2L	9.0	29.6	2900	87.5	0.93	16	6.5	1.8	2.3											
K21R	160 L	K20R	160 S	1.5	14.5	985	80.0	0.76	3.6	6.2	1.7	2.8	0.078	120									
	6-2L		6-2L	13.0	42.8	2900	87.0	0.93	23	6.2	1.8	2.2											
K21R	180 M	K20R	160 M	2.0	19.4	983	81.0	0.79	4.5	5.7	1.5	2.5	0.090	136									
	6-2L		6-2L	17.0	55.8	2910	88.0	0.93	30	6.8	2.1	2.4											
K21R	180 L	K20R	180 S	2.5	24.1	989	76.5	0.72	6.6	5.8	1.3	2.7	0.138	170									
	6-2L		6-2L	22.0	71.8	2925	89.5	0.93	38	7.0	2.0	2.4											
K21R	200 L	K20R	180 M	3.5	33.8	988	80.5	0.74	8.5	6.0	1.5	2.7	0.168	220									
	6-2L		6-2L	27.0	88.3	2920	90.0	0.93	46.5	6.7	1.8	2.2											
K21R	225 S	K20R	200 M	4.0	38.6	990	85.0	0.73	9.3	6.5	1.6	2.8	0.275	270									
	6-2L		6-2L	32.0	104	2950	90.0	0.93	55	7.8	1.9	2.6											
K21R	225 M	K20R	200 L	4.5	43.4	990	84.0	0.74	10.5	6.4	1.6	2.7	0.313	300									
	6-2L		6-2L	37.0	120	2950	90.5	0.93	63.5	7.7	1.9	2.5											
K21R	250 M	K20R	225 M	5.0	48.2	990	82.0	0.78	11.5	6.6	1.8	2.5	0.525	375									
	6-2L		6-2L	45.0	146	2945	91.0	0.93	76.5	7.0	1.9	2.2											
K21R	280 S	K20R	250 S	6.5	62.6	992	86.0	0.76	14.5	7.4	2.2	2.7	0.950	520									
	6-2L		6-2L	55.0	177	2965	91.0	0.93	94	7.5	1.5	2.5											
K21R	280 M	K20R	250 M	8.0	77.2	989	86.0	0.76	17.5	7.0	1.9	2.7	1.11	580									
	6-2L		6-2L	75.0	242	2960	91.5	0.93	127	7.0	1.6	2.3											
K21R	315 S	K20R	280 S	10.0	96.6	989	85.5	0.81	21	6.9	1.9	2.3	1.96	740									
	6-2L		6-2L	90.0	290	2960	92.0	0.93	152	7.2	1.3	2.4											
K21R	315 M	K20R	280 M	13.0	125	990	83.5	0.82	27.5	6.8	1.8	2.3	2.27	840									
	6-2L		6-2L	110	354	2965	93.0	0.93	184	7.5	1.5	2.5											
K21R	315 MX	K20R	315 S	16.0	154	992	82.0	0.77	36.5	7.7	2.0	2.8	2.73	1000									
	6-2L		6-2L	132	426	2960	93.5	0.93	219	7.8	1.7	2.5											
K21R	315 MY	K20R	315 M	20.0	192	993	84.5	0.83	41	7.1	2.0	2.4	4.82	1200									
	6-2L		6-2L	160	515	2970	93.5	0.93	266	8.0	1.8	2.7											

¹⁾ Delta configuration possible upon request

Three-phase motors with squirrel-cage rotor

Pole-changing, for constant load torque
 with two separate windings in Y-Y configuration
 with surface cooling, duty type S1, continuous duty
 Thermal class 155, degree of protection IP 55

Motor selection data															Design point 400 V, 50 Hz	
Type				P _B	M _B	n _B	η _B	cosφ _B	I _B	I _A /I _B	M _A /M _B	M _S /M _B	M _K /M _B	J	m	
			kW	Nm	rpm	%	-	A	-	-	-	-	-	kgm ²	kg	
Synchronous speed 1000/1500 rpm – 6- to 4-pole version																
K21R	71 K	K20R	63 K	0.10	1.03	925	37.0	0.69	0.57	2.4	1.2	1.2	1.8	0.00045	7.8	
	6-4		6-4	0.15	1.00	1440	54.0	0.70	0.57	3.2	1.2	1.2	1.8		7.1 ¹⁾	
K21R	71 G	K20R	63 G	0.13	1.35	920	41.0	0.68	0.67	2.4	1.3	1.3	1.8	0.00060	8.1	
	6-4		6-4	0.20	1.34	1430	53.0	0.73	0.75	3.2	1.2	1.2	1.8		7.4 ¹⁾	
K21R	80 K	K20R	71 K	0.20	2.03	940	49.0	0.69	0.86	2.8	1.5	1.5	2.0	0.00130	11.0	
	6-4		6-4	0.28	1.86	1440	56.0	0.69	1.05	3.5	1.3	1.3	2.0		10.0 ¹⁾	
K21R	80 G	K20R	71 G	0.25	2.51	950	59.0	0.66	0.93	2.8	1.6	1.6	2.1	0.00175	12.5	
	6-4		6-4	0.37	2.44	1450	70.0	0.73	1.05	3.9	1.4	1.4	2.1		11.0 ¹⁾	
K21R	90 S	K20R	80 K	0.35	3.52	950	63.0	0.73	1.10	3.4	1.3	1.3	1.7	0.00325	16.0	
	6-4		6-4	0.60	3.95	1450	69.0	0.78	1.60	4.5	1.3	1.3	1.8		15.0 ¹⁾	
K21R	90 L	K20R	80 G	0.50	5.05	945	63.0	0.74	1.55	3.4	1.5	1.5	1.7	0.00425	19.0	
	6-4		6-4	0.90	5.99	1435	68.0	0.81	2.35	4.3	1.4	1.4	1.7		18.0 ¹⁾	
K21R	100L	K20R	90 L	0.80	7.96	960	72.0	0.73	2.20	4.1	1.4	1.4	1.9	0.00625	24.0	
	6-4		6-4	1.20	7.93	1445	74.0	0.83	2.80	4.9	1.2	1.2	1.8		24.0 ¹⁾	
K21R	100 LX	K20R	100 S	1.10	10.9	965	72.0	0.74	3.00	4.1	1.3	1.3	2.0	0.00900	28.0	
	6-4		6-4	1.60	10.5	1450	73.0	0.83	3.80	4.9	1.3	1.3	1.8		28.0 ¹⁾	
K21R	112 M	K20R	100 L	1.60	16.1	950	70.0	0.79	4.15	5.5	1.4	1.4	2.0	0.01225	33.5	
	6-4		6-4	2.40	16.0	1435	75.0	0.87	5.30	5.5	1.6	1.6	2.0		32.5 ¹⁾	
K21R	132 S	K20R	112 M	1.5	14.8	970	74.0	0.79	3.7	5.3	1.4	1.3	2.5	0.018	46	
	6-4		6-4	2.2	14.5	1445	74.5	0.91	4.7	5.4	1.1	1.0	2.2			
K21R	132 M	K20R	112 MX	2.2	21.7	965	75.0	0.80	5.3	5.6	1.4	1.3	2.6	0.023	53	
	6-4		6-4	3.0	19.8	1450	78.0	0.90	6.2	6.1	1.4	1.0	2.4			
K21R	132 MX	K20R	132 S	2.6	25.6	970	79.0	0.83	5.7	5.2	1.7	1.5	2.4	0.043	70	
	6-4		6-4	3.8	24.9	1460	81.0	0.90	7.5	5.5	1.4	1.1	2.2			
K21R	160 M	K20R	132 M	3.4	33.5	970	81.0	0.83	7.3	5.9	1.7	1.5	2.5	0.053	86	
	6-4		6-4	5.0	32.7	1460	82.0	0.91	9.7	5.8	1.4	1.0	2.2			
K21R	160 L	K20R	160 S	5.5	54.1	970	81.0	0.87	11.5	5.2	1.6	1.3	2.1	0.113	114	
	6-4		6-4	7.5	49.2	1455	82.0	0.91	14.5	5.2	1.3	1.1	2.2			
K21R	180 L	K20R	160 M	7.5	73.8	970	83.0	0.88	15	5.4	1.7	1.4	2.1	0.145	138	
	6-4		6-4	10.5	68.7	1460	83.0	0.91	20	5.6	1.5	1.0	2.0			
K21R	200 L	K20R	180 S	9.0	87.7	980	86.0	0.88	17	6.0	1.7	1.1	2.3	0.228	175	
	6-4		6-4	12.5	81.2	1470	84.0	0.90	24	5.8	1.5	0.7	2.4			
K21R	200 LX	K20R	180 M	11.0	107	980	86.0	0.88	21	7.2	2.1	1.5	2.7	0.268	200	
	6-4		6-4	15.0	97.5	1470	86.0	0.91	27.5	7.5	1.6	1.0	2.6			
K21R	225 M	K20R	200 M	15.0	146	980	88.0	0.90	27.5	7.3	2.3	1.7	2.8	0.443	265	
	6-4		6-4	20.0	130	1475	88.0	0.92	35.5	8.0	1.9	1.3	3.0			
K21R	250 M	K20R	225 M	18.0	175	985	89.0	0.88	33	7.5	2.8	2.3	2.7	0.825	360	
	6-4		6-4	25.0	162	1470	89.0	0.91	44.5	6.3	1.7	1.1	2.3			
K21R	280 S	K20R	250 S	22.0	212	990	89.0	0.88	40.5	7.8	2.5	1.9	2.6	1.28	465	
	6-4		6-4	30.0	193	1482	89.0	0.91	53.5	7.5	1.9	1.1	2.4			
K21R	280 M	K20R	250 M	27.0	261	988	89.5	0.89	49	8.0	2.7	2.0	2.6	1.48	520	
	6-4		6-4	37.0	240	1475	89.5	0.92	65	6.1	1.6	0.8	1.9			
K21R	315 S	K20R	280 S	37.0	357	990	91.5	0.88	66.5	9.0	2.6	2.4	3.2	2.63	690	
	6-4		6-4	50.0	322	1485	91.0	0.91	87	7.5	1.6	1.3	2.7			
K21R	315 M	K20R	280 M	45.0	434	990	91.5	0.86	82.5	8.1	2.0	1.8	2.6	3.33	800	
	6-4		6-4	60.0	386	1485	92.0	0.91	103	6.7	1.4	0.8	2.1			
K21R	315 MX	K20R	315 S	60.0	579	990	91.4	0.88	108	8.0	2.3	2.1	3.0	3.60	880	
	6-4		6-4	90.0	579	1485	90.5	0.88	163	8.0	1.8	1.3	3.0			
K21R	315 MY	K20R	315 M	75.0	724	990	92.8	0.88	133	8.0	2.2	2.0	2.8	6.00	1050	
	6-4		6-4	110	706	1488	91.5	0.87	199	8.0	2.0	1.5	3.0			
K21R	315 L	K20R	315 L	100					upon request					6.76	1250	
	6-4		6-4	150												

¹⁾ Weights for K20R
 Delta configuration possible upon request

Three-phase motors with squirrel-cage rotor

Pole-changing, enhanced output, for constant load torque
 with two separate windings in Y-Y configuration
 with surface cooling, duty type S1, continuous duty
 Thermal class 155, degree of protection IP 55

Motor selection data													Design point 400 V, 50 Hz		
Type				P_B	M_B	n_B	η_B	$\cos\phi_B$	I_B	I_A/I_B	M_A/M_B	M_S/M_B	M_K/M_B	J	m
									400 V						
									A	-	-	-	-	kgm ²	kg
Synchronous speed 1000/1500 rpm – 6- to 4-pole version															
K21R	132 S	K20R	112 M	2.0	20.0	955	69.0	0.86	4.9	4.3	1.2	1.0	1.9	0.018	46
	6-4		6-4	3.1	20.4	1450	76.0	0.86	6.8	6.6	1.7	1.3	2.6		
K21R	132 M	K20R	112 MX	2.6	27.9	960	71.0	0.86	6.6	5.1	1.3	1.2	2.4	0.023	53
	6-4		6-4	4.2	28.3	1450	75.0	0.88	9.4	6.6	1.9	1.4	2.6		
K21R	132 MX	K20R	132 S	3.3	32.3	975	80.0	0.82	7.3	5.2	1.6	1.4	2.5	0.043	70
	6-4		6-4	4.9	31.9	1465	78.0	0.85	10.5	6.7	1.9	1.4	2.6		
K21R	160 M	K20R	132 M	4.5	44.3	970	79.0	0.81	10	5.2	1.6	1.3	2.5	0.053	86
	6-4		6-4	6.9	45.0	1465	78.0	0.89	14.5	6.6	1.8	1.4	2.4		
K21R	160 L	K20R	160 S	6.5	64.0	970	82.0	0.85	13.5	6.2	2.0	1.6	2.6	0.113	114
	6-4		6-4	9.5	62.4	1455	82.0	0.88	19	6.8	1.7	1.5	2.6		
K21R	180 L	K20R	160 M	9.5	93.1	975	84.0	0.87	19	5.3	1.6	1.2	2.0	0.145	138
	6-4		6-4	14.0	91.9	1455	84.0	0.90	26.5	5.7	1.7	1.3	2.1		
K21R	200 L	K20R	180 S	13.5	132	975	86.0	0.88	25.5	6.5	2.0	1.5	2.5	0.228	175
	6-4		6-4	16.0	104	1470	82.0	0.85	33	6.3	1.7	1.3	2.5		
K21R	200 LX	K20R	180 M	15.0	146	980	87.0	0.88	28.5	7.0	2.2	1.5	2.7	0.268	200
	6-4		6-4	18.0	117	1475	82.0	0.85	37.5	7.7	2.0	1.4	2.8		
K21R	225 M	K20R	200 M	20.0	196	975	88.0	0.89	37	7.2	2.1	1.5	2.8	0.443	265
	6-4		6-4	26.0	170	1465	88.0	0.90	47.5	7.0	1.6	1.2	2.2		
K21R	250 M	K20R	225 M	25.0	244	980	89.0	0.88	46	6.9	2.2	1.5	2.5	0.825	360
	6-4		6-4	35.0	227	1470	89.0	0.89	64	6.4	1.6	1.1	2.2		
K21R	280 S	K20R	250 S	30.0	290	987	89.0	0.87	56	7.5	2.4	1.7	2.4	1.28	465
	6-4		6-4	40.0	257	1485	84.5	0.82	83.5	7.8	2.0	1.3	2.5		
K21R	280 M	K20R	250 M	37.0	359	985	89.5	0.90	66.5	6.8	2.0	1.5	2.2	1.48	520
	6-4		6-4	45.0	289	1485	88.0	0.87	85	6.2	1.6	1.1	2.0		
K21R	315 S	K20R	280 S	55.0	532	988	91.5	0.88	98.5	7.5	2.4	1.9	2.7	2.63	690
	6-4		6-4	63.0	407	1480	91.0	0.89	112	7.5	1.6	1.1	2.7		
K21R	315 M	K20R	280 M	65.0	627	990	92.0	0.89	115	7.7	2.0	1.6	2.5	3.33	800
	6-4		6-4	80.0	513	1490	89.0	0.83	156	8.2	1.8	1.1	2.7		
K21R	315 MX	K20R	315 S	80.0	773	988	90.5	0.89	143	8.0	2.2	1.7	2.8	3.60	880
	6-41)		6-4 ¹⁾	100	642	1487	90.0	0.88	182	9.0	2.1	1.3	3.0		
K21R	315 MY	K20R	315 M	100	965	990	92.0	0.88	178	8.5	2.2	1.8	2.8	6.00	1050
	6-4		6-4	120	770	1488	88.0	0.83	237	8.0	1.9	1.5	2.9		
K21R	315 L	K20R	315 L	100	965	990								6.76	1250
	6-4		6-4	150	965	1485				upon request					

¹⁾ Only available in WKL
 Delta configuration possible upon request

Three-phase motors with squirrel-cage rotor

Pole-changing, for quadratically increasing load torque
 Fan drives with two separate windings in Y-Y configuration
 with surface cooling, duty type S1, continuous duty
 Thermal class 155, degree of protection IP 55

Motor selection data															Design point 400 V, 50 Hz				
Type			P_B	M_B	n_B	η_B	$\cos\phi_B$	I_B	I_A/I_B	M_A/M_B	M_S/M_B	M_K/M_B	J	m					
									400 V										
									kW	Nm	rpm	%	-	A	-	-	-	kgm ²	kg
Synchronous speed 1000/1500 rpm – 6- to 4-pole version																			
K21R	71 K	K20R	63 K	0.06	0.61	940	36.0	0.69	0.35	2.3	1.3	1.3	1.7	0.00045	7.8				
	6-4L		6-4L	0.18	1.22	1415	62.0	0.73	0.58	3.4	1.4	1.4	1.8		7.1 ¹⁾				
K21R	71 G	K20R	63 G	0.08	0.81	945	37.5	0.67	0.46	2.4	1.4	1.4	1.8	0.00060	8.1				
	6-4L		6-4L	0.25	1.70	1405	61.0	0.78	0.76	3.2	1.3	1.3	1.7		7.4 ¹⁾				
K21R	80 K	K20R	71 K	0.12	1.21	950	48.0	0.69	0.52	2.5	1.3	1.3	1.8	0.00130	11.0				
	6-4L		6-4L	0.40	2.71	1410	60.0	0.77	1.25	3.8	1.4	1.4	1.8		10.0 ¹⁾				
K21R	80 G	K20R	71 G	0.16	1.60	955	53.0	0.69	0.63	3.0	1.3	1.3	1.7	0.00175	12.5				
	6-4L		6-4L	0.55	3.69	1425	65.0	0.79	1.55	4.1	1.4	1.4	1.8		11.5 ¹⁾				
K21R	90 S	K20R	80 K	0.25	2.51	950	57.0	0.73	0.87	3.1	1.4	1.4	1.7	0.00325	16.0				
	6-4L		6-4L	0.75	5.03	1425	68.5	0.83	1.90	4.8	1.5	1.5	1.8		15.0 ¹⁾				
K21R	90 L	K20R	80 G	0.37	3.70	955	59.0	0.73	1.25	3.4	1.3	1.3	1.6	0.00425	19.0				
	6-4L		6-4L	1.10	7.37	1425	71.0	0.83	2.70	4.7	1.5	1.5	1.8		18.0 ¹⁾				
K21R	100 L	K20R	90 L	0.50	4.95	965	63.0	0.71	1.60	3.9	1.5	1.5	1.9	0.00625	24.0				
	6-4L		6-4L	1.50	9.95	1440	76.0	0.83	3.45	5.2	1.5	1.5	1.9		24.0 ¹⁾				
K21R	100 LX	K20R	100 S	0.75	7.38	970	67.0	0.69	2.35	4.4	1.4	1.4	2.0	0.00900	28.0				
	6-4L		6-4L	2.00	13.3	1440	74.5	0.85	4.55	6.1	1.8	1.8	2.4		28.0 ¹⁾				
K21R	112 M	K20R	100 L	1.00	9.90	965	66.0	0.77	2.85	4.0	1.2	1.2	1.7	0.01225	33.5				
	6-4L		6-4L	3.00	19.9	1440	77.0	0.82	6.85	6.0	1.8	1.8	2.5		32.5 ¹⁾				
K21R	132 S	K20R	112 M	1.5	14.8	970	68.5	0.80	4	4.3	1.2	1.1	2.2	0.018	46				
	6-4L		6-4L	3.7	24.5	1445	73.5	0.86	8.5	5.1	1.2	1.1	2.3						
K21R	132 MX	K20R	132 S	2.2	21.5	975	77.5	0.82	5	5.0	1.7	1.2	2.4	0.043	70				
	6-4L		6-4L	6	39.2	1460	77.5	0.83	13.5	5.8	2.0	1.4	2.9						
K21R	160 M	K20R	132 M	3	29.4	975	76.5	0.84	6.7	4.6	1.4	1.1	2.0	0.053	86				
	6-4L		6-4L	8.2	54.2	1445	80.0	0.88	17	5.4	1.6	1.1	2.1						
K21R	160 L	K20R	160 S	4.4	43.1	975	78.0	0.81	10	4.8	1.7	1.5	2.1	0.078	120				
	6-4L		6-4L	13	85.6	1450	85.0	0.87	25.5	4.9	1.5	1.2	1.9						
K21R	180 M	K20R	160 M	5.4	52.5	982	79.0	0.76	13	5.2	1.9	1.6	2.5	0.090	136				
	6-4L		6-4L	16	105	1450	86.0	0.88	30.5	4.9	1.5	1.2	1.9						
K21R	180 L	K20R	180 S	6.7	65.3	980	82.0	0.81	14.5	4.7	1.4	1.3	2.1	0.138	170				
	6-4L		6-4L	20	130	1470	89.0	0.84	38.5	5.8	1.7	1.5	2.5						
K21R	200 L	K20R	180 M	9	87.3	985	84.0	0.79	19.5	5.0	1.4	1.3	2.1	0.168	220				
	6-4L		6-4L	26	169	1470	90.0	0.85	49	6.4	1.6	1.5	2.5						
K21R	225 S	K20R	200 M	12	117	982	84.0	0.79	26	5.0	1.3	1.2	2.0	0.275	270				
	6-4L		6-4L	34	220	1475	90.5	0.82	66	6.4	1.9	1.4	2.5						
K21R	225 M	K20R	200 L	14	136	985	86.0	0.78	30	5.4	1.8	1.5	2.3	0.313	300				
	6-4L		6-4L	40	259	1475	91.0	0.86	74	6.5	1.9	1.6	2.5						
K21R	250 M	K20R	225 M	18	174	988	86.0	0.75	40.5	5.5	1.7	1.5	2.0	0.525	375				
	6-4L		6-4L	50	323	1478	92.0	0.85	92.5	7.0	1.9	1.3	2.3						
K21R	280 S	K20R	250 S	23	222	988	86.0	0.74	52	5.4	1.5	1.1	1.8	0.950	520				
	6-4L		6-4L	68	439	1480	92.0	0.84	127	7.0	1.8	1.6	2.4						
K21R	280 M	K20R	250 M	28	271	988	88.0	0.73	63	5.5	1.6	1.4	1.9	1.11	580				
	6-4L		6-4L	80	515	1485	93.0	0.84	148	7.0	2.0	1.8	2.6						
K21R	315 S	K20R	280 S	34	329	988	87.0	0.73	77.5	5.5	1.4	1.3	1.8	1.96	740				
	6-4L		6-4L	95	611	1485	93.5	0.84	175	7.0	1.6	1.3	2.2						
K21R	315 M	K20R	280 M	40	386	990	88.0	0.73	90	6.0	1.3	1.3	1.7	2.27	840				
	6-4L		6-4L	115	740	1485	94.0	0.85	208	7.5	1.9	1.7	2.4						
K21R	315 MX	K20R	315 S	45	434	990	89.0	0.73	100	6.5	1.3	1.2	1.7	2.73	1000				
	6-4L		6-4L	125	804	1485	94.0	0.85	226	7.5	1.9	1.7	2.4						
K21R	315 MY	K20R	315 M	55	530	992	91.5	0.77	113	6.4	1.5	1.3	2.0	4.82	1200				
	6-4L		6-4L	145	931	1487	94.5	0.87	255	7.0	1.6	1.4	2.3						
K21R	315 L	K20R	315 L	55	528	995								5.93	1450				
	6-4L		6-4L	185	1186	1490				upon request									

¹⁾ Weights for K20R
 Delta configuration possible upon request

Three-phase motors with squirrel-cage rotor

Pole-changing, for constant load torque
 with two separate windings in Y-Y configuration
 with surface cooling, duty type S1, continuous duty
 Thermal class 155, degree of protection IP 55

Motor selection data													Design point 400 V, 50 Hz		
Type				P_B	M_B	n_B	η_B	$\cos\phi_B$	I_B	I_A/I_B	M_A/M_B	M_S/M_B	M_K/M_B	J	m
400 V															
				kW	Nm	rpm	%	-	A	-	-	-	-	kgm ²	kg
Synchronous speed 750/3000 rpm – 8- to 2-pole version															
K21R	71 K	K20R	63 K	0.025	0.33	720	17.0	0.57	0.37	1.8	2.9		4.0	0.00040	6.8
	8-2		8-2	0.09	0.29	2950	28.5	0.65	0.71	3.5	1.9		4.0		6.3 ¹⁾
K21R	71 G	K20R	63 G	0.04	0.54	705	27.5	0.62	0.34	2.0	1.7		2.4	0.00050	7.8
	8-2		8-2	0.16	0.52	2945	50.5	0.66	0.69	4.3	1.8		2.6		7.1 ¹⁾
K21RW	80 K	K20RW	71 K	0.075	1.07	670	34.5	0.55	0.56	2.0	2.6		2.6	0.00087	10.6
	8-2		8-2	0.30	1.00	2855	57.5	0.77	1.00	4.6	2.5		2.6		9.9 ¹⁾
K21RW	80 G	K20RW	71 G	0.11	1.59	660	37.0	0.56	0.77	2.0	2.3		2.4	0.00107	11.7
	8-2		8-2	0.45	1.51	2850	60.0	0.80	1.35	4.8	2.2		2.3		11.0 ¹⁾
K21RW	90 S	K20RW	80 K	0.18	2.55	675	43.0	0.60	1.05	2.3	2.2		2.3	0.00207	15.5
	8-2		8-2	0.75	2.55	2805	66.0	0.87	1.89	5.0	2.0		1.9		14.5 ¹⁾
K21RW	90 L	K20RW	80 G	0.25	3.59	665	44.0	0.61	1.35	2.6	2.4		2.8	0.00260	18.0
	8-2		8-2	1.00	3.40	2810	69.0	0.89	2.35	5.8	2.2		1.8		17.0 ¹⁾
K21RW	100 L	K20RW	90 L	0.33	4.60	685	46.5	0.54	1.90	2.6	2.8		2.9	0.00400	23.5
	8-2		8-2	1.30	4.38	2835	72.0	0.87	3.00	5.8	2.0		2.1		22.5 ¹⁾
K21RW	100 LX	K20RW	100 S	0.55	7.72	680	53.0	0.61	2.45	2.8	1.9		2.3	0.00725	30.0
	8-2		8-2	2.20	7.40	2840	73.0	0.87	5.00	6.1	2.4		2.5		30.0 ¹⁾
K21RW	112 M	K20RW	100 L	0.75	10.5	680	57.0	0.60	3.15	3.0	1.9		2.4	0.00900	37.0
	8-2		8-2	3.00	10.1	2840	75.0	0.90	6.45	6.1	2.0		2.0		36.0 ¹⁾
K21RW	112 MX	K20RW	100 LX	1.0	14.4	665	60.0	0.64	3.75	2.8	1.9		2.0	0.0111	45
	8-2		8-2	4.0	13.5	2820	75.0	0.91	8.45	6.1	2.1		2.0		44.0 ¹⁾
K21R	132 S	K20R	112 M	1.1	14.5	725	61.5	0.57	4.5	3.7	1.5		2.4	0.015	50
	8-2		8-2	4.5	15.1	2850	78.0	0.92	9.1	6.0	1.8		2.1		
K21R	132 M	K20R	132 S	1.3	17.0	730	64.0	0.50	5.9	3.6	1.5		2.6	0.028	69
	8-2		8-2	5.5	18.1	2910	80.5	0.85	11.50	6.3	1.6		2.4		
K21R	160 M	K20R	132 M	1.8	23.5	730	68.5	0.50	7.6	3.8	1.5		2.6	0.035	86
	8-2		8-2	7.5	24.5	2920	83.0	0.89	14.5	7.0	1.7		2.5		
K21R	160 L	K20R	160 S	2.7	35.1	735	77.5	0.54	9.3	4.6	1.7		2.8	0.078	120
	8-2		8-2	11.0	35.9	2930	84.5	0.87	21.5	7.2	1.8		2.6		
K21R	180 M	K20R	160 M	3.7	48.1	735	76.0	0.59	12	4.4	1.5		2.5	0.090	136
	8-2		8-2	15.0	48.9	2930	84.5	0.84	30.5	7.1	1.9		2.7		
K21R	180 L	K20R	180 S	4.6	59.8	735	78.0	0.55	15.5	4.3	1.4		2.5	0.138	170
	8-2		8-2	18.5	60.2	2935	86.5	0.90	34.5	6.9	1.5		2.4		
K21R	200 L	K20R	180 M	5.5	71.5	735	80.0	0.52	19	4.6	1.6		2.7	0.168	200
	8-2		8-2	22.0	71.3	2945	88.0	0.92	39	7.8	1.7		2.8		
K21R	225 S	K20R	200 M	7.5	96.8	740	82.0	0.47	28	4.6	1.6		2.8	0.275	270
	8-2		8-2	30.0	97.2	2950	88.5	0.90	54.5	7.8	1.7		2.6		
K21R	225 M	K20R	200 L	9.2	119	740	82.5	0.50	32	4.6	1.5		2.6	0.313	300
	8-2		8-2	37.0	120	2950	89.0	0.90	66.5	7.8	1.7		2.6		
K21R	250 M	K20R	225 M	11.0	142	740	83.5	0.58	33	5.4	1.7		2.7	0.525	375
	8-2		8-2	45.0	146	2950	90.0	0.91	79.5	8.1	1.6		2.7		
K21R	280 S	K20R	250 S	13.0	168	740	85.0	0.60	37	6.5	2.0		2.8	0.95	520
	8-2		8-2	55.0	178	2955	92.0	0.92	94	7.6	1.4		2.4		
K21R	280 M	K20R	250 M	18.0	232	740	86.0	0.63	48	6.2	2.0		2.6	1.11	580
	8-2		8-2	75.0	242	2960	92.0	0.92	128	8.3	1.6		2.6		
K21R	315 S	K20R	280 S	22.0	284	740	87.5	0.64	56.5	6.6	2.0		2.6	1.96	740
	8-2		8-2	90.0	290	2965	92.0	0.92	153	8.1	1.2		2.7		
K21R	315 M	K20R	280 M	24.5	317	740	87.0	0.64	63.5	6.7	2.0		2.7	2.27	840
	8-2		8-2	100	322	2965	92.5	0.92	170	8.9	1.2		2.7		
K21R	315 MX	K20R	315 S	28	361	740	87.0	0.68	68.5	6.2	1.9		2.3	2.73	1000
	8-2		8-2	110	354	2965	92.0	0.92	188	8.1	1.3		2.6		
K21R	315 MY	K20R	315 M	37	474	745	88.5	0.67	90	6.6	2.0		2.6	4.82	1200
	8-2		8-2	145	466	2970	92.4	0.93	244	8.5	1.4		2.7		
K21R	315 L	K20R	317 L	42.5	545	745	89.0	0.65	106	6.5	1.9		2.7	5.93	1450
	8-2		8-2	170	546	2975	93.0	0.93	284	8.5	1.4		2.7		

¹⁾ Weights for K20R
 Delta configuration possible upon request

Three-phase motors with squirrel-cage rotor

Pole-changing, for quadratically increasing load torque
 Fan drives with two separate windings in Y-Y configuration
 with surface cooling, duty type S1, continuous duty
 Thermal class 155, degree of protection IP 55

Motor selection data													Design point 400 V, 50 Hz											
Type			P_B	M_B	n_B	η_B	$\cos\phi_B$	I_B	I_A/I_B	M_A/M_B	M_S/M_B	M_K/M_B	J	m										
													400 V											
													kW	Nm	rpm	%	-	A	-	-	-	-	kgm ²	kg
Synchronous speed 750/3000 rpm – 8- to 2-pole version																								
K21R	132 S	K20R	112 M	0.42	5.46	735	55.0	0.57	1.9	3.5	1.4		2.8	0.015	50									
	8-2L		8-2L	4.5	15.0	2870	82.0	0.94	8.4	6.6	2.2		2.4											
K21R	132 M	K20R	132 S	0.65	8.45	735	58.0	0.57	2.8	3.5	1.4		2.6	0.028	69									
	8-2L		8-2L	7.0	23.6	2830	86.0	0.93	12.5	6.2	1.7		2.2											
K21R	160 M	K20R	132 M	0.8	10.4	735	59.0	0.57	3.4	3.6	1.4		2.6	0.035	86									
	8-2L		8-2L	9.0	29.6	2900	87.5	0.93	16	6.5	1.8		2.3											
K21R	160 L	K20R	160 S	1.2	15.6	735	70.0	0.69	3.6	4.0	1.5	1.3	2.0	0.078	120									
	8-2L		8-2L	13.0	42.4	2925	84.0	0.87	25.5	6.2	1.8	0.8	2.3											
K21R	180 M	K20R	160 M	1.5	19.5	735	68.0	0.71	4.5	4.0	1.6	1.4	2.2	0.090	136									
	8-2L		8-2L	17.0	55.8	2910	85.5	0.92	31	6.0	1.6	0.9	2.0											
K21R	180 L	K20R	180 S	1.9	24.5	740	68.0	0.61	6.6	4.2	1.3		2.5	0.138	170									
	8-2L		8-2L	22.0	71.8	2925	89.5	0.93	38	7.0	2.0		2.4											
K21R	200 L	K20R	180 M	2.5	32.2	740	74.0	0.63	7.7	4.6	1.4		2.5	0.168	220									
	8-2L		8-2L	27.0	88.3	2920	90.0	0.93	46.5	6.7	1.8		2.2											
K21R	225 S	K20R	200 M	3.2	41.3	740	79.0	0.59	9.9	4.8	1.5		2.6	0.275	270									
	8-2L		8-2L	32.0	104	2950	90.0	0.93	55	7.8	1.9		2.6											
K21R	225 M	K20R	200 L	3.6	46.5	740	77.0	0.62	11	4.6	1.3		2.4	0.313	300									
	8-2L		8-2L	37.0	120	2950	90.5	0.93	63.5	7.7	1.9		2.5											
K21R	250 M	K20R	225 M	4.0	51.6	740	79.0	0.66	11	5.5	1.8		2.5	0.525	375									
	8-2L		8-2L	45.0	146	2945	91.0	0.93	76.5	7.0	1.9		2.2											
K21R	280 S	K20R	250 S	5.2	67.1	740	82.0	0.64	14.5	6.0	2.0		2.5	0.950	520									
	8-2L		8-2L	55.0	177	2965	91.0	0.93	94	7.5	1.5		2.5											
K21R	280 M	K20R	250 M	6.5	83.9	740	83.0	0.66	17	5.4	1.7		2.3	1.11	580									
	8-2L		8-2L	75.0	242	2960	91.5	0.93	127	7.0	1.6		2.3											
K21R	315 S	K20R	280 S	8.0	103	740	84.0	0.69	20	6.3	2.0		2.3	1.96	740									
	8-2L		8-2L	90.0	290	2960	92.0	0.93	152	7.2	1.3		2.4											
K21R	315 M	K20R	280 M	10.0	128	745	81.0	0.69	26	6.0	1.9		2.3	2.27	840									
	8-2L		8-2L	110	354	2965	93.0	0.93	184	7.5	1.5		2.5											
K21R	315 MX	K20R	315 S	13.0	167	745	80.0	0.65	36	6.3	2.1		2.5	2.73	1000									
	8-2L		8-2L	132	612	2060	93.5	0.93	219	7.8	1.7		2.5											
K21R	315 MY	K20R	315 M	17.0	218	745	83.0	0.67	44	7.2	2.4		2.6	4.82	1200									
	8-2L		8-2L	160	515	2970	93.5	0.93	266	8.0	1.8		2.7											

Delta configuration possible upon request

Three-phase motors with squirrel-cage rotor

Pole-changing, for quadratically increasing load torque
 Fan drives with two separate windings in Y-Y configuration
 with surface cooling, duty type S1, continuous duty
 Thermal class 155, degree of protection IP 55

Motor selection data															Design point 400 V, 50 Hz					
Type				P_B	M_B	n_B	η_B	$\cos\phi_B$	I_B	I_A/I_B	M_A/M_B	M_S/M_B	M_K/M_B	J	m					
									400 V											
									kW	Nm	rpm	%	-	A	-	-	-	-	kgm ²	kg
Synchronous speed 750/1500 rpm – 8- to 4-pole version																				
K21R	71 K	K20R	63 K	0.09	1.30	660	31.0	0.64	0.66	2.0	2.0	2.0	2.1	0.00050	6.6					
	8-4		8-4	0.12	0.79	1445	61.0	0.59	0.48	4.0	2.4	2.4	3.0	0.00060	6.6 ¹⁾					
K21R	71 G	K20R	63 G	0.12	1.74	660	35.5	0.63	0.77	2.2	1.9	1.9	2.1	0.00060	8.3					
	8-4		8-4	0.20	1.34	1425	65.5	0.72	0.61	4.2	1.8	1.8	2.3	0.00060	7.6 ¹⁾					
K21R	80 K	K20R	71 K	0.18	2.51	685	44.0	0.70	0.85	2.5	1.6	1.6	2.0	0.00130	10.5					
	8-4		8-4	0.30	2.05	1400	67.0	0.87	0.74	3.8	1.4	1.4	1.6	0.00130	9.9 ¹⁾					
K21R	80 G	K20R	71 G	0.25	3.56	670	45.0	0.69	1.17	2.4	1.3	1.3	1.7	0.00175	12.0					
	8-4		8-4	0.40	2.73	1400	73.0	0.84	0.94	4.1	1.3	1.3	1.8	0.00175	11.3 ¹⁾					
K21R	90 S	K20R	80 K	0.35	4.78	700	53.5	0.65	1.45	2.8	1.5	1.5	1.8	0.00300	15.0					
	8-4		8-4	0.55	3.70	1420	70.0	0.88	1.30	4.3	1.4	1.4	1.9	0.00300	14.0 ¹⁾					
K21R	90 L	K20R	80 G	0.44	6.05	695	56.0	0.60	1.89	2.8	1.5	1.5	1.8	0.00375	18.0					
	8-4		8-4	0.75	5.08	1410	72.0	0.86	1.74	4.2	1.3	1.3	1.7	0.00375	17.0 ¹⁾					
K21R	100 L	K20R	90 L	0.70	9.28	720	62.5	0.55	2.95	3.5	1.8	1.8	2.3	0.00625	24.0					
	8-4		8-4	1.10	7.22	1455	78.5	0.85	2.35	6.0	1.9	1.9	2.3	0.00625	24.0 ¹⁾					
K21R	100 LX	K20R	100 S	1.00	13.5	705	70.0	0.68	3.00	3.7	1.5	1.5	2.0	0.00900	28.0					
	8-4		8-4	1.50	10.1	1420	84.0	0.85	3.00	5.6	1.3	1.3	2.0	0.00900	28.0 ¹⁾					
K21R	112 M	K20R	100 L	1.40	19.0	705	68.5	0.66	4.40	4.0	1.8	1.8	2.3	0.01225	33.5					
	8-4		8-4	2.20	14.6	1435	78.5	0.90	4.50	5.8	1.3	1.3	2.2	0.01225	32.5 ¹⁾					
K21R	132 S	K20R	112 M	1.7	22.9	710	72.0	0.72	4.7	4.3	1.7	1.5	2.5	0.018	46					
	8-4		8-4	2.6	17.3	1435	79.0	0.91	5.2	5.8	1.5	1.3	2.5	0.018	46					
K21R	132 M	K20R	112 MX	2.2	29.4	715	72.0	0.71	6.2	4.4	1.8	1.7	2.6	0.023	53					
	8-4		8-4	3.7	24.7	1430	78.0	0.93	7.4	5.4	1.4	1.2	2.3	0.023	53					
K21R	132 MX	K20R	132 S	3.1	40.8	725	76.0	0.70	8.4	4.1	1.6	1.5	2.3	0.043	70					
	8-4		8-4	4.8	31.6	1450	82.0	0.91	9.3	5.6	1.5	1.1	2.3	0.043	70					
K21R	160 M	K20R	132 M	4.3	57.0	720	77.0	0.71	11.5	4.3	1.7	1.6	2.4	0.053	86					
	8-4		8-4	6.5	42.8	1450	83.0	0.91	12.5	6.2	1.7	1.3	2.4	0.053	86					
K21R	160 L	K20R	160 S	6.2	81.7	725	82.0	0.76	14.5	4.7	1.8	1.6	2.2	0.113	114					
	8-4		8-4	9.0	59.1	1455	83.0	0.91	17	6.0	1.7	1.3	2.4	0.113	114					
K21R	180 L	K20R	160 M	8.5	113	720	83.0	0.79	18.5	4.3	1.7	1.5	2.0	0.145	138					
	8-4		8-4	12.5	82.3	1450	85.0	0.91	23.5	5.4	1.6	1.2	2.0	0.145	138					
K21R	200 L	K20R	180 S	11.0	144	730	86.0	0.78	23.5	5.0	1.8	1.5	2.1	0.228	175					
	8-4		8-4	16.0	105	1460	86.0	0.91	29.5	6.2	1.8	1.2	2.2	0.228	175					
K21R	200 LX	K20R	180 M	13.0	170	730	87.0	0.79	27.5	5.3	1.9	1.6	2.3	0.268	220					
	8-4		8-4	19.0	124	1460	88.0	0.92	34	6.9	1.6	1.2	2.7	0.268	220					
K21R	225 M	K20R	200 M	17.5	229	730	88.0	0.78	37	5.7	2.2	1.8	2.4	0.443	265					
	8-4		8-4	25.0	162	1470	88.0	0.92	44.5	7.4	2.1	1.0	2.6	0.443	265					
K21R	250 M	K20R	225 M	24.0	314	730	89.0	0.81	48	5.6	2.0	1.6	2.2	0.825	360					
	8-4		8-4	30.0	195	1470	89.0	0.92	53	8.2	2.5	1.4	2.8	0.825	360					
K21R	280 S	K20R	250 S	28.0	364	735	90.0	0.78	57.5	5.4	2.1	1.5	1.9	1.28	465					
	8-4		8-4	38.0	246	1475	89.5	0.90	68	7.2	2.1	1.2	2.4	1.28	465					
K21R	280 M	K20R	250 M	34.0	441	737	90.5	0.79	68.5	5.4	2.1	1.5	2.1	1.48	520					
	8-4		8-4	45.0	291	1478	90.0	0.90	80	7.7	2.4	1.3	2.5	1.48	520					
K21R	315 S	K20R	280 S	42.0	542	740	92.0	0.81	81.5	5.7	1.6	1.3	2.0	2.63	690					
	8-4		8-4	55.0	355	1480	92.0	0.92	94	8.5	1.9	1.2	2.5	2.63	690					
K21R	315 M	K20R	280 M	55.0	710	740	92.5	0.79	109	5.8	1.7	1.5	2.1	3.33	800					
	8-4		8-4	75.0	482	1485	92.5	0.91	129	7.7	2.0	1.3	2.6	3.33	800					
K21R	315 MX	K20R	315 S	70.0	901	742	92.5	0.76	144	7.0	2.3	1.8	2.5	3.60	880					
	8-4		8-4	105	675	1485	91.5	0.89	186	8.5	2.5	1.6	3.0	3.60	880					
K21R	315 MY	K20R	315 M	85.0	1097	740	93.8	0.78	168	7.0	2.3	1.9	2.7	6.00	1050					
	8-4		8-4	125	804	1485	92.6	0.90	216	8.5	2.5	1.6	2.8	6.00	1050					
K21R	315 L	K20R	315 L	120	1570	730								6.76	1250					
	8-4		8-4	150	965	1485				upon request				6.76	1250					

¹⁾ Weights for K20R

Three-phase motors with squirrel-cage rotor

Pole-changing, enhanced output, for constant load torque with Δ-YY-Dahlander winding with surface cooling, duty type S1, continuous duty
Thermal class 155, degree of protection IP 55

Motor selection data													Design point 400 V, 50 Hz		
Type				P_B	M_B	n_B	η_B	$\cos\phi_B$	I_B	I_A/I_B	M_A/M_B	M_S/M_B	M_K/M_B	J	m
				kW	Nm	rpm	%	-	A	-	-	-	-	kgm ²	kg
Synchronous speed 750/1500 rpm – 8- to 4-pole version															
K21R	132 S	K20R	112 M	2.2	29.8	705	71.0	0.75	6	3.5	1.5	1.5	2.1	0.018	46
	8-4		8-4	3.3	22.1	1425	76.0	0.93	6.7	4.6	1.3	1.2	2.0		
K21R	132 M	K20R	112 MX	2.6	35.0	710	73.0	0.72	7.1	4.1	1.7	1.7	2.5	0.023	53
	8-4		8-4	4.2	28.0	1430	79.0	0.93	8.3	4.9	1.4	1.3	2.3		
K21R	132 MX	K20R	132 S	4.0	53.0	720	76.0	0.68	11	3.5	1.6	1.5	2.1	0.043	70
	8-4		8-4	6.0	40.0	1445	80.0	0.89	12	4.8	1.5	1.2	2.1		
K21R	160 M	K20R	132 M	5.0	66.8	715	76.0	0.71	13.5	4.4	1.8	1.7	2.2	0.053	86
	8-4		8-4	7.8	51.8	1440	83.0	0.91	15	5.5	1.6	1.2	2.2		
K21R	160 L	K20R	160 S	7.0	92.2	725	82.0	0.76	16	4.5	2.0	1.6	2.2	0.113	114
	8-4		8-4	11.0	72.5	1450	83.0	0.92	21	5.4	1.8	1.3	2.3		
K21R	180 L	K20R	160 M	10.0	132	725	83.0	0.75	23	4.8	2.0	1.7	2.2	0.145	138
	8-4		8-4	16.0	106	1445	85.0	0.90	30	5.4	1.8	1.2	2.3		
K21R	200 L	K20R	180 S	15.0	198	725	86.0	0.80	31.5	4.0	1.6	1.4	1.9	0.228	175
	8-4		8-4	21.0	138	1455	85.0	0.91	39	5.5	1.7	1.1	2.1		
K21R	200 LX	K20R	180 M	17.5	232	720	86.0	0.76	38.5	4.7	1.8	1.5	2.2	0.268	200
	8-4		8-4	25.0	166	1440	84.0	0.89	48.5	6.2	1.5	1.1	2.5		
K21R	225 M	K20R	200 M	22.0	290	725	87.0	0.79	46	5.1	2.0	1.7	2.2	0.443	265
	8-4		8-4	30.0	197	1455	87.0	0.89	56	6.6	1.9	0.9	2.4		
K21R	250 M	K20R	225 M	28.0	366	730	90.0	0.77	58.5	5.2	2.0	1.6	2.2	0.825	360
	8-4		8-4	38.0	247	1470	89.5	0.90	68	7.1	2.5	1.4	2.8		
K21R	280 S	K20R	250 S	35.0	455	735	91.0	0.78	71	4.8	2.0	1.5	1.8	1.28	465
	8-4		8-4	50.0	324	1475	89.0	0.90	90	6.1	2.0	1.2	2.3		
K21R	280 M	K20R	250 M	45.0	585	735	90.0	0.79	91.5	5.5	2.1	1.5	2.2	1.48	520
	8-4		8-4	60.0	389	1475	90.0	0.88	109	7.2	1.9	1.3	2.6		
K21R	315 S	K20R	280 S	55.0	710	740	92.0	0.79	109	6.0	1.6	1.5	2.2	2.63	690
	8-4		8-4	80.0	516	1480	91.0	0.91	139	7.0	1.7	1.3	2.4		
K21R	315 M	K20R	280 M	75.0	968	740	92.0	0.79	149	5.1	1.6	1.3	1.9	3.33	800
	8-4		8-4	100	643	1485	91.0	0.90	176	7.0	1.9	1.2	2.4		
K21R	315 MX	K20R	315 S	80.0	1032	740	93.0	0.77	161	6.5	2.0	1.7	2.5	3.60	880
	8-4		8-4	115	740	1485	91.5	0.90	202	7.5	1.9	1.3	2.8		
K21R	315 MY	K20R	315 M	100	1291	740	93.7	0.80	193	6.5	1.9	1.7	2.3	6.00	1050
	8-4		8-4	140	900	1485	92.7	0.91	240	7.5	2.0	1.4	2.5		
K21R	315 L	K20R	315 L	120	1549	740								6.76	1250
	8-4		8-4	150	965	1485				upon request					

Three-phase motors with squirrel-cage rotor

Pole-changing, for quadratically increasing load torque
 Fan drives with Y-YY-Dahlander winding
 with surface cooling, duty type S1, continuous duty
 Thermal class 155, degree of protection IP 55

Motor selection data													Design point 400 V, 50 Hz		
Type	P_B	M_B	n_B	η_B	$\cos\phi_B$	I_B	I_A/I_B	M_A/M_B	M_S/M_B	M_K/M_B	J	m			
	kW	Nm	rpm	%	-	A	-	-	-	-	kgm ²	kg			
Synchronous speed 750/1500 rpm – 8- to 4-pole version															
K21R	71 K	K20R	63 K	0.05	0.70	680	39.0	0.62	0.30	1.9	1.4	1.4	1.7	0.00050	7.8
	8-4L		8-4L	0.20	1.34	1430	61.0	0.67	0.71	3.8	1.7	1.7	2.2		7.1 ¹⁾
K21R	71 G	K20R	63 G	0.075	1.07	670	40.0	0.62	0.44	2.1	1.2	1.2	1.7	0.00060	8.3
	8-4L		8-4L	0.30	2.01	1425	60.0	0.67	1.08	3.7	1.4	1.4	2.1		7.6 ¹⁾
K21R	80 K	K20R	71 K	0.12	1.65	695	50.0	0.70	0.49	2.6	1.2	1.2	2.0	0.00130	10.5
	8-4L		8-4L	0.50	3.41	1400	65.0	0.85	1.31	3.8	1.3	1.3	2.0		9.9 ¹⁾
K21R	80 G	K20R	71 G	0.18	2.51	685	56.0	0.66	0.70	2.6	1.5	1.5	1.8	0.00175	12.0
	8-4L		8-4L	0.70	4.76	1405	68.0	0.83	1.79	4.2	1.6	1.6	2.0		11.3 ¹⁾
K21R	90 S	K20R	80 K	0.25	3.41	700	59.0	0.63	0.97	2.7	1.1	1.1	1.5	0.00300	15.0
	8-4L		8-4L	1.00	6.72	1420	70.0	0.81	2.55	4.5	1.5	1.5	1.8		14.0 ¹⁾
K21R	90 L	K20R	80 G	0.37	5.12	690	63.0	0.64	1.33	2.6	1.2	1.2	1.4	0.00375	18.0
	8-4L		8-4L	1.50	10.2	1400	70.0	0.84	3.70	1.6	1.7	1.7	1.9		17.0 ¹⁾
K21R	100 L	K20R	90 L	0.50	6.82	700	61.0	0.60	1.80	2.8	1.2	1.2	1.9	0.00400	23.5
	8-4L		8-4L	2.00	13.5	1415	74.0	0.81	4.80	5.0	1.3	1.3	1.6		22.5 ¹⁾
K21R	100 LX	K20R	100 S	0.65	8.74	710	68.0	0.58	2.38	3.2	1.3	1.3	2.0	0.00725	30.0
	8-4L		8-4L	2.50	16.6	1440	81.0	0.81	5.50	7.0	1.4	1.4	2.0		30.0 ¹⁾
K21R	112 M	K20R	100 L	0.90	12.1	710	69.0	0.57	3.30	3.3	1.7	1.7	2.3	0.00900	37.0
	8-4L		8-4L	3.60	23.9	1440	81.0	0.81	7.90	6.3	2.2	2.2	2.5		36.0 ¹⁾
K21R	132 M	K20R	112 MX	1.1	14.6	720	65.0	0.67	3.6	4.4	2.0	2.0	3.1	0.023	53
	8-4L		8-4L	4.5	29.7	1445	71.0	0.83	11	6.1	1.9	1.8	3.4		
K21R	132 MX	K20R	132 S	1.8	24.2	710	76.0	0.79	4.5	3.6	1.3	1.0	1.7	0.043	70
	8-4L		8-4L	6.5	43.1	1440	80.0	0.91	13	5.8	2.0	1.0	2.2		
K21R	160 M	K20R	132 M	2.3	30.5	720	80.0	0.76	5.5	3.6	1.5	1.2	1.7	0.053	86
	8-4L		8-4L	9.0	59.5	1445	79.5	0.88	18.5	5.4	1.8	1.2	2.3		
K21R	160 L	K20R	160 S	3.5	46.1	725	82.0	0.68	9.1	3.2	1.5	1.0	1.6	0.078	120
	8-4LF		8-4LF	12.5	81.5	1465	86.0	0.83	25.5	7.0	2.4	1.9	2.9		
K21R	180 M	K20R	160 M	4.5	59.3	725	83.0	0.69	11.5	4.0	1.5	1.3	1.8	0.090	136
	8-4LF		8-4LF	16.0	104	1470	87.0	0.82	32.5	7.5	2.4	1.8	3.0		
K21R	180 L	K20R	180 S	5.0	65.4	730	84.0	0.67	13	5.0	1.8	1.5	2.1	0.138	170
	8-4LF		8-4LF	20.0	130	1475	88.0	0.82	40	6.2	1.8	1.2	2.2		
K21R	200 L	K20R	180 M	7.2	94.2	730	87.0	0.69	17.5	5.3	1.9	1.6	2.3	0.168	220
	8-4LF		8-4LF	26.0	169	1470	89.0	0.83	51	6.9	1.6	1.2	2.7		
K21R	225 S	K20R	200 M	9.5	123	735	87.5	0.67	23.5	5.7	2.2	1.8	2.4	0.275	270
	8-4LF		8-4LF	35.0	226	1478	89.0	0.78	73	7.4	2.1	1.0	2.6		
K21R	225 M	K20R	200 L	11.5	149	735	89.0	0.67	28	5.6	2.0	1.6	2.2	0.313	300
	8-4LF		8-4LF	42.0	271	1478	90.0	0.78	86.5	8.2	2.5	1.4	2.8		
K21R	250 M	K20R	225 M	12.0	155	740	89.0	0.63	31	5.4	2.1	1.5	1.9	0.53	375
	8-4LF		8-4LF	48.0	309	1485	91.0	0.82	93	7.2	2.1	1.2	2.4		
K21R	280 S	K20R	250 S	14.0	181	738	90.0	0.80	28	5.4	2.1	1.5	2.1	1.28	465
	8-4L		8-4L	50.0	323	1480	86.0	0.86	97.5	7.7	2.4	1.3	2.5		
K21R	280 M	K20R	250 M	17.0	220	738	90.0	0.82	33	5.7	1.6	1.3	2.0	1.48	520
	8-4L		8-4L	60.0	388	1478	88.0	0.88	112	8.5	1.9	1.2	2.5		
K21R	315 S	K20R	280 S	21.0	270	742	92.0	0.78	42	5.8	1.7	1.5	2.1	2.63	690
	8-4L		8-4L	80.0	515	1485	91.0	0.89	143	7.7	2.0	1.3	2.6		
K21R	315 M	K20R	280 M	28.0	361	740	92.0	0.80	55	7.0	2.3	1.8	2.5	3.33	800
	8-4L		8-4L	95.0	611	1485	91.0	0.91	166	8.5	2.5	1.6	3.0		
K21R	315 MX	K20R	315 S	36.0	465	740	92.5	0.78	72	7.0	2.3	1.9	2.7	3.60	880
	8-4L		8-4L	110	707	1485	90.0	0.87	203	8.5	2.5	1.6	2.8		
K21R	315 MY	K20R	315 M	44.0	570	738	93.3	0.80	85	7.0	2.3	1.8	2.5	6.00	1050
	8-4L		8-4L	135	869	1485	93.0	0.90	233	8.5	2.5	1.6	2.7		
K21R	315 L	K20R	315 L	48.0	618	742								6.67	1250
	8-4L		8-4L	160	1026	1490				upon request					
K21R	315 LX	K20R	315 LX	55.0	705	745								8.60	1630
	8-4L		8-4L	220	1409	1491				upon request					

¹⁾ Weights for K20R

Three-phase motors with squirrel-cage rotor

Pole-changing, for quadratically increasing load torque
 Fan drives with two separate windings in Y-Y configuration
 with surface cooling, duty type S1, continuous duty
 Thermal class 155, degree of protection IP 55

Motor selection data													Design point 400 V, 50 Hz		
Type				P_B	M_B	n_B	η_B	$\cos\phi_B$	I_B	I_A/I_B	M_A/M_B	M_S/M_B	M_K/M_B	J	m
									400 V						
				kW	Nm	rpm	%	-	A	-	-	-	-	kgm ²	kg
Synchronous speed 750/1500 rpm – 8- to 4-pole version															
K21R	80 K	K20R	71 K	0.09	1.25	690	36.0	0.66	0.55	2.0	1.6	1.5	1.9	0.00087	10.6
	8-4L		8-4L	0.37	2.49	1420	61.0	0.76	1.15	3.7	1.3	1.3	1.8		9.9 ¹⁾
K21R	80 G	K20R	71 G	0.12	1.66	690	40.0	0.67	0.65	2.20	1.35	1.35	1.80	0.00107	11.7
	8-4L		8-4L	0.50	3.39	1410	66.5	0.79	1.37	4.0	1.50	1.45	1.90		11.0 ¹⁾
K21R	90 S	K20R	80 K	0.18	2.40	715	44.0	0.60	0.98	2.50	1.35	1.35	1.00	0.00325	16.0
	8-4L		8-4L	0.75	5.03	1425	69.0	0.81	1.94	4.10	1.30	1.25	1.70		15.0 ¹⁾
K21R	90L	K20R	80G	0.25	3.32	720	51.0	0.56	1.26	2.60	1.40	1.35	1.90	0.00425	19.0
	8-4L		8-4L	1.00	6.65	1435	70.0	0.80	2.58	4.90	1.60	1.50	1.85		18.0 ¹⁾
K21R	100 L	K20R	90 L	0.37	4.87	725	60.0	0.55	1.62	3.00	1.90	1.80	2.10	0.00625	24.0
	8-4L		8-4L	1.50	9.95	1440	75.5	0.81	3.55	5.20	1.40	1.30	1.85		24.0 ¹⁾
K21R	100 LX	K20R	100S	0.50	6.63	720	53.0	0.64	2.12	3.30	1.20	1.20	2.30	0.00900	28.0
	8-4L		8-4L	2.20	14.64	1435	72.0	0.82	5.40	5.40	1.60	1.60	2.50		28.0 ¹⁾
K21R	112 M	K20R	100 L	0.62	8.22	720	52.0	0.65	2.65	3.20	1.40	1.40	2.10	0.01225	33.5
	8-4L		8-4L	3.00	20.0	1435	76.0	0.82	6.95	6.00	2.10	2.00	2.60		32.5 ¹⁾
K21R	132 S	K20R	112 M	0.9	11.9	720	65.0	0.65	3.7	4.0	1.4	1.4	2.3	0.015	50
	8-4LZ		8-4LZ	3.6	23.6	1455	80.0	0.80	6.2	5.9	1.5	1.0	2.9		
K21R	132 M	K20R	132 S	1.1	14.3	735	65.0	0.55	4.4	3.8	2.1	1.9	2.8	0.028	69
	8-4LZ		8-4LZ	4.5	29.6	1455	83.0	0.82	9.5	5.0	1.3	1.1	2.2		
K21R	160 M	K20R	132 M	1.4	18.2	735	69.0	0.54	5.4	4.0	2.2	2.1	2.8	0.035	86
	8-4LZ		8-4LZ	6.0	39.0	1470	84.5	0.82	12.5	6.4	1.8	1.4	2.7		
K21R	160 L	K20R	160 S	2.2	28.6	735	75.5	0.67	6.3	4.3	1.7	1.5	2.2	0.078	120
	8-4LZ		8-4LZ	9.0	58.5	1470	87.0	0.87	17	6.6	2.0	1.6	2.6		
K21R	180 M	K20R	160 M	3.0	39.0	735	80.0	0.64	8.5	4.8	2.2	1.8	2.5	0.090	136
	8-4LZ		8-4LZ	11.0	70.7	1485	87.0	0.86	21	7.2	2.0	1.7	2.9		
K21R	180 L	K20R	180 S	4.5	58.1	740	80.5	0.65	12.5	4.5	1.7	1.6	2.3	0.138	170
	8-4LZ		8-4LZ	16.0	104	1475	89.0	0.85	30.5	6.8	1.9	1.7	2.7		
K21R	200 L	K20R	180 M	5.0	64.5	740	82.0	0.65	13.5	5.0	1.7	1.7	2.7	0.168	220
	8-4LZ		8-4LZ	18.5	120	1475	90.5	0.86	34.5	7.3	1.9	1.5	2.9		
K21R	225 S	K20R	200 M	7.0	90.4	740	84.0	0.56	21.5	5.3	2.2	2.0	3.0	0.275	270
	8-4LZ		8-4LZ	28.0	181	1480	90.0	0.80	56	7.4	2.0	1.8	3.0		
K21R	225 M	K20R	200 L	9.5	123	740	84.0	0.55	29.5	5.2	2.3	2.1	3.1	0.313	300
	8-4LZ		8-4LZ	35.0	226	1480	90.0	0.78	72	7.6	2.2	1.8	3.1		
K21R	250 M	K20R	225 M	11.5	149	737	85.5	0.65	30	4.5	1.4	1.2	1.6	0.525	375
	8-4LZ		8-4LZ	42.0	271	1480	92.5	0.84	78	7.8	2.2	1.6	2.6		
K21R	280 S	K20R	250 S	14.0	181	740	88.0	0.63	36.5	4.6	1.4	1.1	1.6	0.950	520
	8-4LZ		8-4LZ	48.0	309	1485	93.5	0.85	87	8.3	2.2	1.8	2.6		
K21R	280 M	K20R	250 M	19.0	245	740	86.0	0.63	50.5	4.4	1.3	1.1	1.6	1.11	580
	8-4LZ		8-4LZ	70.0	456	1465	92.0	0.82	134	8.0	2.4	1.9	2.7		
K21R	315 S	K20R	280 S	23.0	297	740	86.5	0.63	61	5.0	1.2	1.2	1.6	1.96	740
	8-4LZ		8-4LZ	83.0	534	1485	93.5	0.88	146	6.7	1.4	1.3	1.9		
K21R	315 M	K20R	280 M	28.0	360	742	88.0	0.68	67.5	5.9	1.9		2.3	2.27	840
	8-4LZ		8-4LZ	95.0	611	1485	92.5	0.87	170	7.8	1.9		2.5		
K21R	315 MX	K20R	315 S	36.0	463	742	85.5	0.61	99.5	5.0	1.4	1.3	1.7	2.73	1000
	8-4LZ		8-4LZ	110	708	1483	93.5	0.84	202	6.4	1.3	1.3	2.0		
K21R	315 MY	K20R	315 M	40.0	513	745	87.0	0.65	102	6.0	1.5		1.8	4.82	1200
	8-4LZ		8-4LZ	160	1029	1485	94.0	0.86	286	8.0	1.6		2.2		

¹⁾ Weights for K20R

Delta configuration possible upon request

Three-phase motors with squirrel-cage rotor

Pole-changing, for constant load torque
with two separate windings in Y-Y configuration
with surface cooling, duty type S1, continuous duty
Thermal class 155, degree of protection IP 55

Motor selection data													Design point 400 V, 50 Hz											
Type				P_B	M_B	n_B	η_B	$\cos\phi_B$	I_B	I_A/I_B	M_A/M_B	M_S/M_B	M_K/M_B	J	m									
													400 V											
													kW	Nm	rpm	%	-	A	-	-	-	-	kgm ²	kg
Synchronous speed 750/1500 rpm – 8- to 6-pole version																								
K21R	132 S	K20R	112 M	1.3	17.2	720	65.0	0.70	4.1	4.2	1.5		2.3	0.018	46									
	8-6		8-6	1.8	17.7	970	75.0	0.73	4.7	6.0	1.7		2.5											
K21R	132 M	K20R	112 MX	2.3	30.5	720	69.0	0.71	6.8	4.0	1.5		2.3	0.023	53									
	8-6		8-6	3.0	29.6	970	74.0	0.74	7.9	5.2	1.6		2.6											
K21R	132 MX	K20R	132 S	2.8	37.1	720	73.0	0.74	7.5	4.4	1.8		2.5	0.043	70									
	8-6		8-6	4.0	39.6	965	76.0	0.81	9.4	4.6	1.5		2.4											
K21R	160 M	K20R	132 M	4.0	53.4	715	73.5	0.76	10.5	4.3	1.7		2.4	0.053	86									
	8-6		8-6	5.5	53.9	975	78.5	0.81	12.5	4.8	1.5		2.4											
K21R	160 L	K20R	160 S	6.0	79.6	720	80.0	0.76	14	5.0	1.9		2.5	0.113	114									
	8-6		8-6	8.0	78.4	975	82.0	0.77	18.5	6.0	1.8		2.4											
K21R	180 L	K20R	160 M	8.0	106	720	81.0	0.81	17.5	5.2	2.0		2.5	0.145	138									
	8-6		8-6	10.5	103	970	83.0	0.85	21.5	5.1	1.7		2.2											
K21R	200 L	K20R	180 S	10.5	139	720	83.0	0.83	22	5.0	1.8		2.2	0.228	175									
	8-6		8-6	13.0	127	975	85.0	0.83	26.5	5.9	1.7		2.3											
K21R	200 LX	K20R	180 M	11.0	144	730	84.0	0.74	25.5	6.4	2.2		2.5	0.268	200									
	8-6		8-6	15.0	146	980	85.0	0.79	32	6.4	2.0		2.5											
K21R	225 M	K20R	200 M	14.0	182	735	86.0	0.81	29	6.5	2.0		2.6	0.443	265									
	8-6		8-6	18.5	179	985	86.0	0.83	37.5	7.0	3.0		3.0											
K21R	250 M	K20R	225 M	19.0	247	735			upon request					0.825	360									
	8-6		8-6	25.0	242	985																		
K21R	280 S	K20R	250 S	24.0	310	740	89.0	0.83	47	6.0	2.0		2.5	1.28	465									
	8-6		8-6	30.0	291	985	89.0	0.87	56	6.8	2.0		2.5											
K21R	280 M	K20R	250 M	30.0	387	740	89.0	0.81	60	6.6	2.2		2.3	1.48	520									
	8-6		8-6	38.0	368	985	89.0	0.82	75	7.0	2.0		2.3											
K21R	315 S	K20R	280 S	36.0	463	742	91.0	0.79	72.5	7.0	2.4		2.6	2.63	690									
	8-6		8-6	45.0	435	988	92.0	0.86	82	5.9	1.3		2.2											
K21R	315 M	K20R	280 M	60.0	774	740	90.0	0.77	125	7.3	2.1		2.3	3.33	800									
	8-6		8-6	80.0	773	988	92.0	0.85	148	6.5	1.7		2.4											
K21R	315 MX	K20R	315 S	65.0	839	740	90.0	0.81	129	6.4	2.0		2.1	3.60	880									
	8-6		8-6	87.0	839	990	90.0	0.85	164	7.0	1.8		2.4											
K21R	315 MY	K20R	315 M	80.0	1032	740	92.0	0.80	157	7.2	2.5		2.5	6.00	1050									
	8-6		8-6	110	1061	990	92.0	0.86	201	6.8	1.5		1.9											
K21R	315 L	K20R	315 L	80.0	1032	740			upon request					6.76	1250									
	8-6		8-6	120	1158	990																		

Delta configuration possible upon request

Three-phase motors with squirrel-cage rotor

Pole-changing, for quadratically increasing load torque
 Fan drives with two separate windings in Y-Y configuration
 with surface cooling, duty type S1, continuous duty
 Thermal class 155, degree of protection IP 55

Motor selection data														Design point 400 V, 50 Hz			
Type	P_B	M_B	n_B	η_B	$\cos\phi_B$	I_B	I_A/I_B	M_A/M_B	M_S/M_B	M_K/M_B	J	m					
						400 V											
						kW	Nm	rpm	%	-	A	-	-	-	-	kgm ²	kg
Synchronous speed 750/1000 rpm – 8- to 6-pole version																	
K21R	71 G	K20R	63 G	0.05	0.70	685	30.0	0.65	0.37	1.9	1.7	1.7	2.0	0.00060	8.3		
	8-6L		8-6L	0.11	1.17	895	36.0	0.79	0.56	2.1	1.2	1.2	1.4		7.6 ¹⁾		
K21R	80 K	K20R	71 K	0.09	1.20	715	34.0	0.64	0.60	2.3	1.7	1.7	2.4	0.00130	11		
	8-6L		8-6L	0.18	1.79	960	48.0	0.60	0.90	3.1	2.0	1.8	2.6		10 ¹⁾		
K21R	80 G	K20R	71 G	0.12	1.64	700	44.0	0.68	0.58	2.4	1.5	1.5	1.9	0.00175	12.5		
	8-6L		8-6L	0.25	2.51	950	57.0	0.67	0.94	3.4	1.7	1.7	2.1		11.5 ¹⁾		
K21R	90 S	K20R	80 K	0.24	3.23	710	47.0	0.70	1.05	2.4	1.1	1.0	1.5	0.00325	16.0		
	8-6L		8-6L	0.48	4.83	950	63.5	0.68	1.60	3.3	1.3	1.3	1.8		15.0 ¹⁾		
K21R	90 L	K20R	80 G	0.33	4.47	705	48.0	0.66	1.50	2.6	1.3	1.3	1.8	0.00425	19.0		
	8-6L		8-6L	0.66	6.63	950	65.0	0.66	2.25	3.7	1.6	1.6	2.0		18.0 ¹⁾		
K21R	100 L	K20R	90 L	0.45	6.05	710	51.5	0.68	1.85	2.8	1.5	1.5	1.7	0.00625	24.0		
	8-6L		8-6L	0.90	9.14	940	66.0	0.77	2.55	3.5	1.3	1.2	1.6		24.0 ¹⁾		
K21R	100 LX	K20R	100 S	0.60	8.24	695	53.5	0.75	2.15	2.8	1.5	1.5	1.7	0.00900	28.0		
	8-6L		8-6L	1.20	12.6	910	70.5	0.83	2.95	3.5	1.3	1.2	1.6		28.0 ¹⁾		
K21R	112 M	K20R	100 L	0.80	10.7	715	59.5	0.67	2.90	3.6	1.5	1.5	2.3	0.01225	33.5		
	8-6L		8-6L	1.60	16.0	955	76.0	0.76	4.00	4.7	1.5	1.5	2.3		32.5 ¹⁾		
K21R	112 MX	K20R	100 LX	1.00	13.6	700	63.0	0.75	3.05	3.2	1.2	1.1	1.6	0.01390	37.0		
	8-6L		8-6L	2.20	22.4	940	75.0	0.78	5.45	4.4	1.4	1.3	1.9		36.0 ¹⁾		
K21R	132 S	K20R	112 M	1.0	13.4	710	60.0	0.79	3.05	3.6	1.1	1.0	1.9	0.018	46		
	8-6L		8-6L	2.2	22.0	955	71.5	0.81	5.45	5.0	1.4	1.3	2.5				
K21R	132 M	K20R	112 MX	1.7	22.7	715	61.5	0.74	5.4	4.5	1.9	1.9	2.9	0.023	53		
	8-6L		8-6L	3.5	35.2	950	73.0	0.81	8.5	4.5	1.3	1.2	2.4				
K21R	132 MX	K20R	132 S	2.2	29.0	725	70.0	0.74	6.1	4.4	1.6	1.5	2.4	0.043	70		
	8-6L		8-6L	4.5	44.3	970	76.5	0.78	11	5.5	1.8	1.6	2.7				
K21R	160 M	K20R	132 M	2.5	32.7	730	72.0	0.75	6.7	4.5	1.7	1.7	2.4	0.053	86		
	8-6L		8-6L	5.5	54.4	965	81.0	0.83	12	5.1	1.6	1.4	2.3				
K21R	160 L	K20R	160 S	4.5	58.9	730	78.0	0.80	10.5	5.0	1.9	1.8	2.5	0.113	114		
	8-6L		8-6L	9.0	88.6	970	82.0	0.84	19	5.0	1.5	1.3	2.2				
K21R	180 L	K20R	160 M	6.0	78.5	730	77.0	0.83	13.5	4.6	1.7	1.5	2.1	0.145	138		
	8-6L		8-6L	12.0	118	970	83.5	0.86	24	5.5	1.6	1.3	2.3				
K21R	200 L	K20R	180 S	7.0	91.6	730	78.0	0.85	15	4.3	1.3	1.3	1.8	0.228	175		
	8-6L		8-6L	17.0	168	965	86.5	0.87	32.5	4.8	1.3	1.4	2.0				
K21R	200 LX	K20R	180 M	10.0	131	730	80.0	0.82	22	5.7	2.0	1.2	2.6	0.268	200		
	8-6L		8-6L	21.0	208	965	87.0	0.87	40	5.2	1.7	1.7	2.2				
K21R	225 M	K20R	200 M	12.0	156	735	82.0	0.85	25	6.3	2.0	1.7	2.7	0.443	265		
	8-6L		8-6L	26.0	253	980	87.0	0.85	50.5	6.9	2.2	1.7	3.0				
K21R	250 M	K20R	225 M	15.0	198	725	85.0	0.85	30	4.4	1.6	1.4	1.7	0.825	360		
	8-6L		8-6L	35.0	343	975	89.0	0.87	65	5.4	1.6	1.3	2.0				
K21R	280 S	K20R	250 S	20.0	258	740	86.0	0.82	41	6.5	2.1	1.6	2.6	1.28	465		
	8-6L		8-6L	45.0	436	985	90.0	0.83	87	6.5	2.1	1.4	2.6				
K21R	280 M	K20R	250 M	25.0	323	740	86.0	0.82	51	5.2	1.8	1.6	2.1	1.48	520		
	8-6L		8-6L	55.0	533	985	90.5	0.86	102	5.7	1.8	1.4	2.1				
K21R	315 S	K20R	280 S	30.0	384	745	89.5	0.79	61	6.3	2.0	1.4	2.3	2.63	690		
	8-6L		8-6L	65.0	627	990	93.0	0.85	119	7.1	1.8	1.3	2.6				
K21R	315 M	K20R	280 M	35.0	451	740	88.0	0.84	68.5	4.2	1.7	1.4	2.0	3.33	800		
	8-6L		8-6L	75.0	724	990	92.0	0.86	137	7.4	1.9	1.6	2.6				
K21R	315 MX	K20R	315 S	40.0	516	740	91.0	0.79	80.5	4.0	1.4	1.2	1.7	3.60	880		
	8-6L		8-6L	85.0	820	990	92.0	0.82	163	6.5	1.5	1.4	2.2				
K21R	315 MY	K20R	315 M	55.0	705	745	90.0	0.81	109	4.5	1.5	1.2	1.9	6.00	1050		
	8-6L		8-6L	115	1109	990	94.0	0.82	215	7.0	1.6	1.4	2.3				

¹⁾ Weights for K20R
 Delta configuration possible upon request

Three-phase motors with squirrel-cage rotor

Pole-changing, for quadratically increasing load torque
 Fan drives with two separate windings in Y-Y configuration
 with surface cooling, duty type S1, continuous duty
 Thermal class 155, degree of protection IP 55

Motor selection data													Design point 400 V, 50 Hz		
Type				P_B	M_B	n_B	η_B	$\cos\phi_B$	I_B	I_A/I_B	M_A/M_B	M_S/M_B	M_K/M_B	J	m
				kW	Nm	rpm	%	-	A	-	-	-	-	kgm ²	kg
Synchronous speed 500/3000 rpm – 12- to 2-pole version															
K21R	132 S	K20R	112 M	0.25	4.92	485	34.0	0.54	2	2.2	1.7		2.5	0.015	50
	12-2L		12-2L	4.5	15.0	2870	82.0	0.93	8.5	6.6	2.2		2.4		
K21R	132 M	K20R	132 S	0.35	6.82	490	42.0	0.43	2.8	2.3	1.6		2.5	0.028	69
	12-2L		12-2L	7.0	23.1	2890	84.0	0.93	13	5.8	1.5		2.0		
K21R	160 M	K20R	132 M	0.45	8.77	490	44.0	0.44	3.4	2.4	1.5		2.5	0.035	86
	12-2L		12-2L	9.0	29.7	2895	86.0	0.93	16	6.2	1.7		2.2		
K21R	160 L	K20R	160 S	0.55	10.6	495	46.0	0.44	3.9	2.9	2.0		2.5	0.078	120
	12-2L		12-2L	12.0	39.3	2915	87.0	0.93	21.5	6.8	2.0		2.3		
K21R	180 M	K20R	160 M	0.65	12.7	490	53.0	0.47	3.8	3.0	1.7		2.5	0.090	136
	12-2L		12-2L	13.0	42.5	2920	87.0	0.93	23	7.0	2.0		2.3		
K21R	180 L	K20R	180 S	0.8	15.4	495	46.0	0.47	5.3	2.7	1.4		2.5	0.138	170
	12-2L		12-2L	17.0	55.4	2930	89.0	0.93	29.5	6.9	1.7		2.3		
K21R	200 L	K20R	180 M	1.1	21.2	495	52.0	0.44	6.9	2.9	1.7		2.5	0.168	200
	12-2L		12-2L	22.0	71.5	2940	90.0	0.93	38	8.0	2.0		2.5		
K21R	225 S	K20R	200 M	1.5	28.9	495	59.0	0.37	9.9	3.0	1.6		2.5	0.275	270
	12-2L		12-2L	28.0	91.1	2935	90.0	0.93	48.5	6.3	1.5		2.0		
K21R	225 M	K20R	200 L	1.7	32.8	495	57.0	0.38	11.5	3.0	1.6		2.5	0.313	300
	12-2L		12-2L	34.0	110	2940	90.0	0.93	58.5	6.8	1.6		2.1		
K21R	250 M	K20R	225 M	2.0	38.6	495	62.0	0.42	11	3.8	2.0		2.5	0.525	375
	12-2L		12-2L	39.0	127	2940	90.0	0.92	68	5.8	1.4		2.0		
K21R	280 S	K20R	250 S	2.5	48.2	495	67.0	0.40	13.5	4.0	2.1		2.5	0.950	520
	12-2L		12-2L	50.0	161	2965	90.0	0.92	87	8.3	1.7		2.5		
K21R	280 M	K20R	250 M	3.5	67.5	495	71.0	0.45	16	3.8	1.6		2.2	1.11	580
	12-2L		12-2L	68.0	219	2960	90.0	0.92	119	7.7	1.6		2.2		
K21R	315 S	K20R	280 S	4.0	77.1	495	72.0	0.45	18	4.8	2.3		2.5	1.96	740
	12-2L		12-2L	80.0	258	2965	91.0	0.93	136	8.0	1.5		2.5		
K21R	315 M	K20R	280 M	4.5	86.8	495	71.0	0.49	18.5	4.6	2.0		2.4	2.27	840
	12-2L		12-2L	90.0	290	2960	92.0	0.92	153	6.8	1.3		2.2		
K21R	315 MX	K20R	315 S	5.5	106	495	71.0	0.50	22.5	4.5	2.0		2.3	2.73	1000
	12-2L		12-2L	105	338	2970	92.0	0.93	177	9.5	2.0		2.5		
K21R	315 MY	K20R	315 M	6.5	125	496	74.0	0.50	25.5	4.7	2.1		2.3	4.82	1200
	12-2L		12-2L	125	402	2970	92.0	0.93	211	7.7	1.7		2.5		

Delta configuration possible upon request

Three-phase motors with squirrel-cage rotor

Pole-changing, for constant load torque
with Δ-YY-Dahlander winding
with surface cooling, duty type S1, continuous duty
Thermal class 155, degree of protection IP 55

Motor selection data													Design point 400 V, 50 Hz		
Type				P _B	M _B	n _B	η _B	cosφ _B	I _B	I _A /I _B	M _A /M _B	M _S /M _B	M _K /M _B	J	m
				kW	Nm	rpm	%	-	A	-	-	-	-	kgm ²	kg
Synchronous speed 500/1000 rpm – 12- to 6-pole version															
K21R	90 L	K20R	80 G	0.20	4.11	465	40.0	0.48	1.50	2.1	2.1	2.1	2.3	0.00425	19.0
	12-6		12-6	0.40	3.98	960	73.0	0.67	1.18	4.5	1.8	1.8	2.3		18.0 ¹⁾
K21R	100 L	K20R	90 L	0.30	6.37	450	41.0	0.53	2.00	1.9	1.3	1.2	1.6	0.00625	24.0
	12-6		12-6	0.60	6.00	955	71.0	0.73	1.67	3.8	1.6	1.5	1.8		24.0 ¹⁾
K21R	100 LX	K20R	100 S	0.50	10.4	460	49.5	0.57	2.60	2.6	1.7	1.7	2.3	0.00900	28.0
	12-6		12-6	1.00	10.1	950	71.5	0.80	2.55	4.5	1.5	1.5	2.1		28.0 ¹⁾
K21R	112 M	K20R	100 L	0.60	12.2	470	49.0	0.49	3.60	2.8	2.5	2.5	2.9	0.01225	33.5
	12-6		12-6	1.20	11.9	965	76.0	0.72	3.15	5.5	2.0	1.9	2.6		32.5 ¹⁾
K21R	112 MX	K20R	100 LX	0.80	16.8	455	52.0	0.56	3.95	2.5	1.8	1.8	2.1	0.01390	37.0
	12-6		12-6	1.50	14.9	960	76.0	0.77	3.70	4.9	1.8	1.6	2.3		36.0 ¹⁾
K21R	132 S	K20R	112 M	0.7	14.1	475	55.0	0.55	3.3	2.9	1.7	1.6	2.5	0.018	46
	12-6		12-6	1.0	9.85	970	79.0	0.78	2.3	6.0	1.8	1.7	2.9		
K21R	132 M	K20R	112 MX	0.9	18.1	475	56.0	0.52	4.5	3.0	1.9	1.9	2.9	0.023	53
	12-6		12-6	1.4	13.8	970	81.0	0.79	3.2	6.2	1.9	1.9	3.0		
K21R	132 MX	K20R	132 S	1.3	25.9	480	62.0	0.53	5.7	2.4	1.6	1.5	2.2	0.043	70
	12-6		12-6	2.0	19.6	975	82.0	0.82	4.3	5.5	1.7	1.4	2.7		
K21R	160 M	K20R	132 M	1.9	38.2	475	64.0	0.57	7.5	3.0	1.6	1.5	1.9	0.053	86
	12-6		12-6	3.0	29.7	965	83.0	0.84	6.2	5.4	1.6	1.4	2.1		
K21R	160 L	K20R	160 S	3.2	63.7	480	73.0	0.60	10.5	3.3	1.7	1.5	2.0	0.113	114
	12-6		12-6	5.0	49.0	975	84.0	0.88	9.8	5.5	1.7	1.4	2.3		
K21R	180 L	K20R	160 M	4.5	89.5	480	75.0	0.60	14.5	3.1	1.9	1.7	1.9	0.145	138
	12-6		12-6	7.5	73.8	970	85.0	0.88	14.5	5.8	1.8	1.5	2.1		
K21R	200 L	K20R	180 S	5.5	108	485	82.0	0.60	16	3.9	1.9	1.3	2.2	0.228	175
	12-6		12-6	8.8	85.8	980	88.0	0.87	16.5	6.3	1.8	1.4	2.4		
K21R	200 LX	K20R	180 M	6.5	128	485	81.0	0.60	19.5	4.4	2.0	1.8	2.4	0.268	200
	12-6		12-6	10.5	102	980	87.0	0.87	20	6.8	2.0	1.5	2.7		
K21R	225 M	K20R	200 M	9.0	177	485	83.0	0.62	25	4.4	2.2	2.0	2.7	0.443	265
	12-6		12-6	14.0	136	980	88.0	0.87	26.5	7.1	2.4	1.6	3.0		
K21R	250 M	K20R	225 M	11.0	217	485	86.0	0.65	28.5	4.1	1.7	1.4	1.8	0.825	360
	12-6		12-6	17.5	171	980	89.0	0.88	32.5	6.3	1.8	1.3	2.3		
K21R	280 S	K20R	250 S	13.5	263	490	87.0	0.62	36	4.3	2.1	1.6	1.9	1.28	465
	12-6		12-6	21.0	203	987	90.0	0.87	38.5	7.0	2.0	1.4	2.3		
K21R	280 M	K20R	250 M	16.5	320	492	87.0	0.60	45.5	4.9	2.3	1.9	2.4	1.48	520
	12-6		12-6	26.0	251	990	90.5	0.87	47.5	7.8	2.4	1.7	2.7		
K21R	315 S	K20R	280 S	22.0	425	494	88.0	0.60	60	4.6	1.6	1.4	2.1	2.63	690
	12-6		12-6	35.0	338	990	92.0	0.85	64.5	6.7	1.6	1.3	2.3		
K21R	315 M	K20R	280 M	32.0	620	493	89.5	0.60	86	4.2	1.7	1.4	2.0	3.33	800
	12-6		12-6	48.0	463	991	93.5	0.86	86	7.4	1.9	1.6	2.6		
K21R	315 MX	K20R	315 S	48.0	936	490	89.5	0.66	117	4.0	1.4	1.2	1.7	3.60	880
	12-6		12-6	70.0	677	987	92.6	0.87	125	6.5	1.5	1.4	2.2		
K21R	315 MY	K20R	315 M	55.0	1072	490	90.0	0.68	130	4.5	1.5	1.2	1.9	6.00	1050
	12-6		12-6	85.0	824	985	92.6	0.88	151	7.0	1.6	1.4	2.3		
K21R	315 L	K20R	315 L	65.0	1267	490								6.76	1250
	12-6		12-6	95.0	921	985				upon request					

¹⁾ Weights for K20R

Three-phase motors with squirrel-cage rotor

Pole-changing, for constant load torque
 with Δ -YY-Dahlander winding
 with surface cooling, duty type S1, continuous duty
 Thermal class 155, degree of protection IP 55

Motor selection data														Design point 400 V, 50 Hz	
Type				P_B	M_B	n_B	η_B	$\cos\phi_B$	I_B	I_A/I_B	M_A/M_B	M_S/M_B	M_K/M_B	J	m
										400 V					
				kW	Nm	rpm	%	-	A	-	-	-	-	kgm ²	kg
Synchronous speed 500/1000 rpm – 12- to 6-pole version															
K21R	132 S	K20R	112 M	0.9	18.2	473	56.0	0.66	3.5	2.8	1.5	1.4	1.8	0.018	46
	12-6		12-6	1.3	13.1	950	77.0	0.85	2.9	4.8	1.4	1.3	2.0		
K21R	132 M	K20R	112 MX	1.1	22.4	470	57.0	0.59	4.7	2.9	1.5	1.5	2.5	0.023	53
	12-6		12-6	1.7	17.0	955	79.0	0.84	3.7	5.1	1.5	1.5	2.3		
K21R	132 MX	K20R	132 S	1.6	32.2	475	61.0	0.54	7	2.3	1.4	1.3	1.9	0.043	70
	12-6		12-6	2.5	24.7	965	81.0	0.85	5.2	4.9	1.5	1.2	2.3		
K21R	160 M	K20R	132 M	2.3	46.7	470	59.0	0.57	9.9	2.9	1.5	1.4	1.7	0.053	86
	12-6		12-6	3.6	36.0	955	81.0	0.83	7.7	5.2	1.6	1.4	2.0		
K21R	160 L	K20R	160 S	3.7	74.2	476	71.0	0.60	12.5	3.1	1.6	1.4	1.8	0.113	114
	12-6		12-6	6.0	59.2	968	83.0	0.87	12	3.1	1.6	1.3	1.8		
K21R	180 L	K20R	160 M	5.5	110	476	74.0	0.63	17	5.6	1.6	1.4	1.5	0.145	138
	12-6		12-6	9.0	89.2	963	84.0	0.86	18	5.3	1.6	1.4	1.8		
K21R	200 L	K20R	180 S	7.5	150	478	80.0	0.64	21	3.5	1.6	1.1	1.7	0.228	175
	12-6		12-6	11.0	108	975	87.0	0.88	20.5	5.3	1.5	1.1	1.9		
K21R	200 LX	K20R	180 M	9.5	189	480	80.0	0.63	27	3.9	1.6	1.4	1.8	0.268	200
	12-6		12-6	15.0	147	975	87.0	0.89	28	5.9	1.7	1.1	2.1		
K21R	225 M	K20R	200 M	11.0	218	482	82.0	0.63	30.5	4.1	2.1	1.9	2.4	0.443	265
	12-6		12-6	18.0	177	973	88.0	0.87	34	6.0	2.1	1.4	2.4		
K21R	250 M	K20R	225 M	13.0	256	485	81.0	0.61	38	3.8	1.8	1.4	2.0	0.825	360
	12-6		12-6	22.0	215	978	88.0	0.88	41	6.5	1.9	1.4	2.3		
K21R	280 S	K20R	250 S	16.0	313	488	86.0	0.61	44	4.3	2.2	1.7	1.9	1.28	465
	12-6		12-6	28.0	273	981	89.0	0.87	52	6.6	1.9	1.3	2.0		
K21R	280 M	K20R	250 M	20.0	392	487	86.0	0.61	55	4.8	2.4	2.0	2.3	1.48	520
	12-6		12-6	35.0	339	987	90.0	0.88	64	7.1	2.3	1.6	2.3		
K21R	315 S	K20R	280 S	27.0	522	494	89.0	0.62	70.5	4.4	1.6	1.4	2.1	2.63	690
	12-6		12-6	50.0	485	985	92.0	0.88	89	5.7	1.4	1.1	2.0		
K21R	315 M	K20R	280 M	35.0	681	491	89.0	0.59	96	4.3	1.8	1.5	1.9	3.33	800
	12-6		12-6	60.0	582	985	92.0	0.86	109	7.3	1.8	1.5	2.4		
K21R	315 MX	K20R	315 S	52.0	1011	491	89.0	0.63	134	4.5	1.8	1.6	2.0	3.60	880
	12-6		12-6	80.0	776	985	92.0	0.87	144	7.4	1.8	1.7	2.5		
K21R	315 MY	K20R	315 M	58.0	1128	491	90.0	0.66	141	4.9	1.8	1.4	2.1	6.00	1050
	12-6		12-6	95.0	921	985	93.0	0.88	168	7.3	1.7	1.5	2.3		

Three-phase motors with squirrel-cage rotor

Pole-changing, for quadratically increasing load torque
 Fan drives with Y-YY-Dahlander winding
 with surface cooling, duty type S1, continuous duty
 Thermal class 155, degree of protection IP 55

Motor selection data													Design point 400 V, 50 Hz		
Type				P_B	M_B	n_B	η_B	$\cos\phi_B$	I_B	I_A/I_B	M_A/M_B	M_S/M_B	M_K/M_B	J	m
				kW	Nm	rpm	%	-	400 V A	-	-	-	-	kgm ²	kg
Synchronous speed 500/1000 rpm – 12- to 6-pole version															
K21R	80 K	K20R	71 K	0.04	0.87	440	28.0	0.65	0.32	1.6	1.5		1.7	0.00130	11.0
	12-6L		12-6L	0.20	2.03	940	53.0	0.74	0.74	3.0	1.4		2.0		10.0 ¹⁾
K21R	80 G	K20R	71 G	0.075	1.69	425	36.0	0.69	0.44	1.9	1.2		1.4	0.00175	12.5
	12-6L		12-6L	0.30	3.06	935	60.0	0.72	1.00	3.5	1.5		2.0		11.5 ¹⁾
K21R	90 S	K20R	80 K	0.10	2.10	455	35.0	0.55	0.75	1.7	1.0		1.2	0.00325	16.0
	12-6L		12-6L	0.40	3.96	965	58.5	0.58	1.70	3.9	1.8		2.3		15.0 ¹⁾
K21R	90 L	K20R	80 G	0.12	2.49	460	40.0	0.49	0.88	1.8	1.2		1.6	0.00425	19.0
	12-6L		12-6L	0.55	5.44	965	66.0	0.60	2.00	4.1	2.0		2.6		18.0 ¹⁾
K21R	100 L	K20R	90 L	0.18	3.74	460	46.0	0.52	1.09	1.9	1.4		1.6	0.00625	24.0
	12-6L		12-6L	1.10	11.2	940	72.0	0.77	2.85	4.0	1.4		1.8		24.0 ¹⁾
K21R	100 LX	K20R	100 S	0.33	7.00	450	49.0	0.62	1.55	2.5	1.4		2.2	0.00900	28.0
	12-6L		12-6L	1.30	13.0	955	65.0	0.69	4.20	4.6	1.4		2.0		28.0 ¹⁾
K21R	112 M	K20R	100 L	0.45	9.55	450	52.0	0.63	2.00	2.9	1.2		1.5	0.01225	33.5
	12-6L		12-6L	1.80	18.0	955	69.0	0.74	5.10	4.5	1.5		2.0		32.5 ¹⁾
K21R	112 MX	K20R	100 LX	0.40	8.21	465	57.0	0.49	2.07	2.4	1.3	1.2	1.9	0.01390	37.0
	12-6L		12-6L	2.50	25.3	945	74.0	0.77	6.4	4.6	1.6	1.3	2.1		36.0 ¹⁾
K21R	132 S	K20R	112 M	0.35	7.11	470	61.0	0.61	1.4	3.0	1.7		2.2	0.018	46
	12-6L		12-6L	1.7	17.09	950	77.0	0.85	3.7	4.4	1.4		2.0		
K21R	132 M	K20R	112 MX	0.5	10.2	470	58.0	0.60	2.1	2.7	1.4		1.9	0.023	53
	12-6L		12-6L	2.3	23.1	950	78.0	0.83	5.1	5.0	1.5		2.3		
K21R	132 MX	K20R	132 S	0.7	13.9	480	69.0	0.59	2.5	2.5	1.4		1.8	0.043	70
	12-6L		12-6L	3.3	32.7	965	82.0	0.85	6.8	4.7	1.6		2.2		
K21R	160 M	K20R	132 M	0.9	17.9	480	71.0	0.58	3.2	2.5	1.4		1.5	0.053	86
	12-6L		12-6L	4.4	43.7	960	82.0	0.85	9.1	5.0	1.6		2.0		
K21R	160 L	K20R	160 S	1.1	21.7	485	75.0	0.60	3.5	3.0	1.9		1.8	0.113	114
	12-6L		12-6L	5.5	53.6	980	84.0	0.83	11.5	6.5	2.5		2.7		
K21R	180 L	K20R	160 M	2.0	39.4	485	77.0	0.60	6.2	3.1	1.9		1.8	0.145	138
	12-6L		12-6L	9.0	88.2	975	84.0	0.84	18.5	6.2	2.3		2.6		
K21R	200 L	K20R	180 S	2.3	45.3	485	82.0	0.60	6.7	4.0	1.9		2.5	0.228	175
	12-6L		12-6L	10.0	97.5	980	88.5	0.85	19	6.5	1.6		2.5		
K21R	200 LX	K20R	180 M	3.0	59.1	485	83.0	0.62	8.4	4.4	1.7		2.2	0.268	200
	12-6L		12-6L	13.0	127	980	88.0	0.85	25	6.7	2.0		2.6		
K21R	225 M	K20R	200 M	3.9	76.3	488	83.0	0.67	10	3.6	1.3		1.8	0.443	265
	12-6L		12-6L	17.0	166	980	87.0	0.88	32	5.0	1.4		2.1		
K21R	250 M	K20R	225 M	5.0	97.4	490	83.0	0.58	15	4.8	2.1		2.3	0.825	360
	12-6L		12-6L	22.0	213	985	89.5	0.83	42.5	7.9	2.2		2.5		
K21R	280 S	K20R	250 S	6.0	117	490	85.0	0.59	17.5	4.0	1.8		2.1	1.28	465
	12-6L		12-6L	26.0	251	990	90.0	0.84	49.5	6.2	1.6		2.3		
K21R	280 M	K20R	250 M	7.5	146	490	88.0	0.70	17.5	3.7	1.6		1.8	1.48	520
	12-6L		12-6L	30.0	289	990	90.5	0.88	54.5	6.0	1.5		2.3		
K21R	315 S	K20R	280 S	12.0	234	490	87.0	0.63	31.5	4.2	1.5		1.9	2.63	690
	12-6L		12-6L	52.0	502	990	91.0	0.85	97	6.8	1.9		2.1		
K21R	315 M	K20R	280 M	15.0	292	490	90.0	0.63	38	5.2	2.3		1.8	3.33	800
	12-6L		12-6L	60.0	579	990	93.0	0.87	107	7.7	2.2		2.4		
K21R	315 MX	K20R	315 S	18.0	347	495	90.0	0.60	48	5.2	2.3		1.9	3.60	880
	12-6L		12-6L	80.0	772	990	93.0	0.88	141	7.2	2.0		2.2		
K21R	315 MY	K20R	315 M	20.0	390	490	90.0	0.63	51	5.0	2.0		1.7	6.00	1050
	12-6L		12-6L	90.0	868	990	93.0	0.86	162	6.5	1.7		1.8		

¹⁾ Weights for K20R

Three-phase motors with squirrel-cage rotor

Pole-changing, for constant load torque
with two separate windings in Y-Δ-YY configuration
with surface cooling, duty type S1, continuous duty
Thermal class 155, degree of protection IP 55

Motor selection data														Design point 400 V, 50 Hz		
Type				P_B	M_B	n_B	η_B	$\cos\phi_B$	I_B	I_A/I_B	M_A/M_B	M_S/M_B	M_K/M_B	J	m	
									400 V							
									A	-	-	-	-	kgm ²	kg	
Synchronous speed 750/1500/3000 rpm - 8-, 4-, 2-pole version																
K21R	80 G	K20R	71 G	0.10	1.36	700	37.0	0.59	0.66	2.3	1.5	1.5	2.3	0.00107	11.7	
	8-4-2		8-4-2	0.18	1.17	1465	55.5	0.60	0.78	3.9	1.7	1.7	3.0			11.0 ¹⁾
				0.30	0.98	2925	64.0	0.80	0.85	5.0	1.2	1.0	2.0			
K21RW	100 L	K20RW	90 L	0.37	5.35	660	50.0	0.67	1.60	2.4	1.8	1.8	1.8	0.00400	23.5	
	8-4-2		8-4-2	0.75	5.03	1425	70.5	0.73	2.10	4.8	2.2	2.0	2.45			22.5 ¹⁾
				1.50	5.22	2745	66.5	0.95	3.45	4.1	1.4	1.1	1.4			
K21RW	100 LX	K20RW	100 S	0.55	7.72	680	53.0	0.61	2.45	2.8	2.2	2.2	2.3	0.00725	30.0	
	8-4-2		8-4-2	1.50	10.2	1405	72.0	0.81	3.70	4.7	2.0	1.8	2.1			30.0 ¹⁾
				1.80	6.03	2850	71.0	0.89	4.15	5.6	2.1	1.7	2.1			
K21RW	112 M	K20RW	100 L	0.70	9.69	690	59.0	0.56	3.05	3.0	2.7	2.7	2.7	0.009	37.0	
	8-4-2		8-4-2	2.00	13.5	1410	75.0	0.80	4.80	5.0	2.0	1.7	2.1			36.0 ¹⁾
				2.40	7.96	2880	75.0	0.87	5.3	6.1	2.0	1.4	2.0			
K21R	132 S	K20R	112 M	1.1	14.6	720	66.0	0.74	3.3	3.6	1.4	1.3	2.3	0.018	46	
	8-4-2		8-4-2	1.5	9.81	1460	76.0	0.89	3.2	5.6	1.3	1.0	2.3			
				1.8	5.93	2900	69.0	0.92	4.1	5.3	1.5	1.0	2.3			
K21R	132 M	K20R	112 MX	1.6	21.2	720	65.0	0.75	4.7	4.1	1.4	1.3	2.4	0.023	53	
	8-4-2		8-4-2	2.2	14.5	1450	77.0	0.91	4.5	4.8	1.1	1.0	2.2			
				2.8	9.22	2900	71.0	0.93	6.1	4.9	1.1	0.8	2.1			
K21R	132 MX	K20R	132 S	2.2	29.0	725	72.0	0.75	5.9	4.1	1.6	1.4	2.2	0.043	70	
	8-4-2		8-4-2	2.8	18.2	1470	79.0	0.89	5.7	6.2	1.6	1.1	2.5			
				3.5	11.4	2920	69.0	0.92	8.0	5.9	1.5	0.9	2.2			
K21R	160 M	K20R	132 M	2.8	36.9	725	73.0	0.75	7.4	3.4	1.6	1.5	2.0	0.053	86	
	8-4-2		8-4-2	3.8	24.7	1470	81.0	0.90	7.5	5.1	1.4	1.1	2.3			
				4.5	14.7	2930	72.0	0.91	9.9	5.6	1.3	0.9	2.5			
K21R	160 L	K20R	160 S	3.7	48.4	730	78.0	0.72	9.5	3.8	1.5	1.3	1.8	0.078	120	
	8-4-2		8-4-2	5.2	33.7	1475	84.0	0.87	10.5	6.4	1.5	1.2	2.5			
				6.5	21.0	2950	80.0	0.92	12.5	7.1	1.7	0.7	2.2			
K21R	180 M	K20R	160 M	4.4	57.6	730	80.0	0.72	11.0	4.0	1.6	1.4	1.8	0.090	136	
	8-4-2		8-4-2	6.5	42.1	1475	85.0	0.88	12.5	6.1	1.5	1.2	2.3			
				7.5	24.3	2950	80.0	0.92	14.5	7.2	1.7	0.8	2.5			
K21R	180 L	K20R	180 S	5.3	69.3	730	83.0	0.71	13.0	3.7	1.2	1.1	1.8	0.138	170	
	8-4-2		8-4-2	7.7	49.7	1480	87.0	0.83	15.5	7.5	1.7	1.4	2.9			
				9.2	29.7	2960	83.0	0.92	17.5	8.5	2.0	0.9	2.6			
K21R	200 L	K20R	180 M	7.0	91.6	730	82.0	0.69	18	4.0	1.2	1.1	1.9	0.168	200	
	8-4-2		8-4-2	10.5	67.8	1480	89.0	0.89	19	7.0	1.4	1.1	2.5			
				12.5	40.6	2940	85.0	0.93	23	8.6	1.6	0.6	2.7			

¹⁾ Weights for K20R

Three-phase motors with squirrel-cage rotor

Pole-changing, for constant load torque
with two separate windings in Y-Δ-YY configuration
with surface cooling, duty type S1, continuous duty
Thermal class 155, degree of protection IP 55

Motor selection data													Design point 400 V, 50 Hz		
Type				P_B	M_B	n_B	η_B	$\cos\phi_B$	I_B	I_A/I_B	M_A/M_B	M_S/M_B	M_K/M_B	J	m
				kW	Nm	rpm	%	-	400 V A	-	-	-	-	kgm ²	kg
Synchronous speed 750/1500/3000 rpm – 8-, 4- to 6-pole version															
K21R	225 S 8-4-2	K20R	200 M 8-4-2	8.8	114	735	86.0	0.66	22.5	4.6	1.4	1.3	2.0	0.275	270
				12.5	80.7	1480	89.0	0.86	23.5	8.0	1.6	1.3	2.9		
				15.5	49.9	2970	83.0	0.93	29.0	9.0	1.7	0.7	3.0		
K21R	225 M 8-4-2	K20R	200 L 8-4-2	11.0	143	735	86.0	0.67	27.5	4.6	1.4	1.4	2.0	0.313	300
				15.5	100	1480	90.0	0.86	29.0	7.7	1.5	1.2	2.8		
				19.0	61.1	2970	83.0	0.93	35.5	8.8	1.8	0.7	2.7		
K21R	250 M 8-4-2	K20R	225 M 8-4-2	13.0	168	740	88.0	0.63	34.0	5.0	1.7	1.3	1.8	0.525	375
				19.0	122	1485	90.0	0.84	36.5	7.3	1.6	1.3	2.3		
				23.0	73.9	2970	82.0	0.92	44.0	8.3	1.6	0.5	2.3		
K21R	280 S 8-4-2	K20R	250 S 8-4-2	18.0	233	740	89.5	0.60	48.5	5.0	1.7	1.4	1.8	0.95	520
				25.0	161	1487	90.5	0.82	48.5	6.9	1.2	1.1	2.3		
				31.0	99.7	2970	84.0	0.92	58.0	8.3	1.1	0.9	2.6		
K21R	280 M 8-4-2	K20R	250 M 8-4-2	22.0	284	740	89.0	0.60	59.5	4.7	1.5	1.2	1.6	1.10	580
				30.0	193	1487	90.5	0.82	58.5	6.4	1.3	1.1	2.1		
				38.0	122	2970	84.0	0.91	72.0	7.7	1.4	0.8	2.4		
K21R	315 S 8-4-2	K20R	280 S ¹⁾ 8-4-2	30.0	385	745	88.0	0.55	89.5	5.6	1.5		2.3	1.96	740
				44.0	283	1485	89.0	0.89	80.0	8.5	1.4		2.6		
				54.0	173	2975	89.5	0.92	94.5	9.2	1.2		2.9		
K21R	315 M 8-4-2	K20R	280 M ¹⁾ 8-4-2	35.0	449	745	88.0	0.56	103	5.6	1.5		2.3	2.27	840
				50.0	320	1490	89.5	0.89	90.5	8.5	1.4		2.6		
				62.0	199	2975	90.0	0.93	107	9.3	1.2		2.9		
K21R	315 MX 8-4-2	K20R	315 S ¹⁾ 8-4-2	40.0	513	745	88.5	0.59	111	5.4	1.3		2.2	2.73	1000
				60.0	386	1485	90.0	0.90	107	8.0	1.5		2.5		
				75.0	241	2975	90.5	0.93	129	9.0	1.2		2.9		
K21R	315 MY 8-4-2	K20R	315 M ¹⁾ 8-4-2	48.0	615	745	90.0	0.63	122	5.9	1.5		2.3	4.82	1200
				70.0	449	1490	91.0	0.91	122	8.0	1.5		2.5		
				84.0	269	2985	91.5	0.93	142	9.1	1.2		2.9		
K21R	315 L 8-4-2	K20R	315 L ¹⁾ 8-4-2	55.0	705	745	91.0	0.65	134	5.8	1.5		2.1	5.93	1450
				80.0	513	1490	91.5	0.91	139	8.3	1.6		2.5		
				100.0	320	2985	92.0	0.94	167	9.5	1.2		3.0		

¹⁾ Provisional operating values

Three-phase motors with squirrel-cage rotor

Pole-changing, for quadratically increasing load torque
 Fan drives with two separate windings in Y-Y-YY configuration
 with surface cooling, duty type S1, continuous duty
 Thermal class 155, degree of protection IP 55

Motor selection data														Design point 400 V, 50 Hz		
Type				P_B	M_B	n_B	η_B	$\cos\phi_B$	I_B	I_A/I_B	M_A/M_B	M_S/M_B	M_K/M_B	J	m	
				kW	Nm	rpm	%	-	A	-	-	-	-	kgm ²	kg	
Synchronous speed 750/1500/3000 rpm – 8-, 4- to 2-pole version																
K21RW	80 K	K20RW	71 K	0.04	0.55	695	24.0	0.63	0.39	1.8	2.0	2.0	2.5	0.00087	10.6	
	8-4-2L		8-4-2L	0.12	0.85	1355	63.0	0.81	0.34	3.2	1.5	1.4	1.6		9.9 ¹⁾	
K21R	80 G	K20R	71 G	0.05	0.67	715	24.0	0.68	0.44	2.0	1.25	1.2	2.5	0.00107	11.7	
			8-4-2L	8-4-2L	0.15	0.99	1440	70.0	0.75	0.41	4.3	1.6	1.5	2.2		11.0 ¹⁾
					0.5	1.64	2910	68.0	0.79	1.35	5.7	2.5	2.3	3.6		
K21R	90 S	K20R	80 K	0.06	0.79	725	21.0	0.77	0.54	1.9	1.2	1.1	2.2	0.00207	15.5	
			8-4-2L	8-4-2L	0.20	1.32	1445	73.0	0.80	0.5	5.1	1.7	1.6	2.4		14.5 ¹⁾
					0.9	2.99	2870	72.0	0.91	2	5.3	1.3	1.2	2.0		
K21R	90 L	K20R	80 G	0.11	1.48	710	28.0	0.77	0.74	2.1	1.2	1.1	2.0	0.00260	18.0	
			8-4-2L	8-4-2L	0.30	1.99	1440	75.0	0.82	0.7	5.2	1.7	1.7	2.4		17.0 ¹⁾
					1.2	3.98	2880	75.0	0.91	2.55	5.9	1.6	1.3	2.2		
K21R	100 L	K20R	90 L	0.15	1.99	720	30.0	0.74	0.98	2.1	1.2	1.1	1.7	0.00400	23.5	
			8-4-2L	8-4-2L	0.37	2.43	1455	76.0	0.78	0.9	5.6	1.7	1.6	2.3		22.5 ¹⁾
					1.7	5.64	2880	73.0	0.91	3.7	6.0	1.7	1.3	1.8		
K21R	100 LX	K20R	100 S	0.18	2.37	725	32.0	0.72	1.15	2.1	1.1	1.1	1.7	0.00725	30.0	
			8-4-2L	8-4-2L	0.45	2.93	1465	80.0	0.75	1.08	5.4	2.2	2.0	2.8		30.0 ¹⁾
					2.2	7.24	2900	78.0	0.90	4.5	6.9	1.7	1.2	2.0		
K21R	112 M	K20R	100 L	0.22	2.90	725	32.0	0.71	1.4	2.3	1.1	1.0	1.6	0.009	37.0	
			8-4-2L	8-4-2L	0.55	3.59	1465	80.0	0.75	1.32	7.0	2.2	2.0	3.1		36.0 ¹⁾
					3.0	9.88	2900	80.0	0.92	5.9	6.7	1.7	1.2	2.0		
K21R	132 S	K20R	112 M	0.23	3.02	728	59.0	0.69	0.8	3.5	1.4		2.5	0.018	46	
			8-4-2L	8-4-2L	0.7	4.56	1465	77.0	0.88	1.5	6.3	1.4		2.7		
					2.7	8.87	2908	64.0	0.89	6.8	4.5	1.3		2.2		
K21R	132 M	K20R	112 MX	0.35	4.60	727	60.0	0.69	1.2	4.2	1.3		2.5	0.023	53	
			8-4-2L	8-4-2L	1.0	6.57	1455	78.0	0.89	2.1	6.4	1.5		3.0		
					4.0	13.2	2900	67.0	0.90	9.6	4.9	1.4		2.4		
K21R	132 MX	K20R	132 S	0.45	5.85	735	70.0	0.71	1.3	5.0	1.8		2.7	0.043	70	
			8-4-2L	8-4-2L	1.3	8.44	1470	80.0	0.89	2.6	7.0	1.5		2.8		
					5.2	17.1	2905	72.0	0.88	12.0	5.0	1.3		2.1		
K21R	160 M	K20R	132 M	0.6	7.85	730	70.0	0.77	1.6	4.0	1.5		2.2	0.053	86	
			8-4-2L	8-4-2L	1.8	11.7	1475	83.0	0.87	3.6	7.7	2.1		3.4		
					7.0	22.9	2925	71.0	0.83	17.0	6.0	1.9		2.8		
K21R	160 L	K20R	160 S	0.9	11.8	730	76.0	0.74	2.3	4.0	1.5		2.0	0.078	120	
			8-4-2L	8-4-2L	2.9	18.8	1475	84.0	0.88	5.7	6.4	1.8		2.5		
					11.0	35.7	2945	80.0	0.91	22.0	6.5	1.8		2.5		

¹⁾ Weights for K20R

Three-phase motors with squirrel-cage rotor

Pole-changing, for quadratically increasing load torque
 Fan drives, with two separate windings in Y-Y-YY configuration
 with surface cooling, duty type S1, continuous duty
 Thermal class 155, degree of protection IP 55

Motor selection data												Design point 400 V, 50 Hz								
Type				P_B	M_B	n_B	η_B	$\cos\phi_B$	I_B	I_A/I_B	M_A/M_B	M_S/M_B	M_K/M_B	J	m					
										400 V										
										kW	Nm	rpm	%	-	A	-	-	-	kgm ²	kg
Synchronous speed 750/1500/3000 rpm – 8-, 4- to 2-pole version																				
K21R	180 M	K20R	160 M	1.2	15.7	731	77.2	0.73	3.1	4.3	1.7		2.1	0.09	136					
	8-4-2L		8-4-2L	3.8	24.6	1476	85.5	0.89	7.2	6.6	1.9		2.6							
				15.0	48.7	2942	83.5	0.92	28.0	6.3	1.7		2.8							
K21R	180 L	K20R	180 S	1.4	18.1	737	79.7	0.66	3.8	4.5	1.4		2.3	0.138	170					
	8-4-2L		8-4-2L	4.3	27.7	1482	86.4	0.85	8.5	7.4	1.5		3.1							
				16.0	51.6	2959	84.7	0.91	30.0	7.6	1.5		2.3							
K21R	200 L	K20R	180 M ¹⁾	2.0	25.8	740	73.0	0.48	8.2	4.3	1.3		2.8	0.168	220					
	8-4-2L		8-4-2L	6.3	40.8	1475	88.0	0.88	11.5	5.8	1.1		2.2							
				24.0	78.0	2940	88.0	0.92	43.0	6.5	1.1		2.5							
K21R	225 S	K20R	200 M ¹⁾	2.5	32.2	740	74.0	0.48	10.0	4.4	1.2		3.2	0.275	270					
	8-4-2L		8-4-2L	8.0	51.8	1475	88.0	0.89	14.5	6.6	1.1		2.7							
				30.0	97.3	2945	87.0	0.87	57.0	6.9	1.2		2.9							
K21R	225 M	K20R	200 L ¹⁾	3.5	45.2	740	74.0	0.51	13.5	4.3	1.1		2.8	0.313	300					
	8-4-2L		8-4-2L	12.0	78.2	1465	89.0	0.90	21.5	5.5	1.0		2.3							
				40.0	130	2940	88.0	0.87	75.5	6.6	1.1		2.9							
K21R	250 M	K20R	225 M ¹⁾	4.0	51.3	745	69.0	0.54	15.5	4.9	1.4		2.7	0.525	375					
	8-4-2L		8-4-2L	13.0	83.9	1480	90.0	0.88	23.5	6.5	1.3		2.4							
				50.0	162	2940	89.5	0.90	89.5	6.5	1.1		2.6							
K21R	280 S	K20R	250 S ¹⁾	5.0	64.1	745	74.5	0.57	17.0	4.8	1.2		2.4	0.95	520					
	8-4-2L		8-4-2L	16.0	103	1485	91.0	0.87	29.0	6.8	1.2		2.4							
				60.0	193	2965	91.0	0.91	105	7.3	1.0		2.6							
K21R	280 M	K20R	250 M ¹⁾	6.0	76.9	745	75.0	0.56	20.5	4.9	1.2		2.5	1.1	580					
	8-4-2L		8-4-2L	19.0	122	1485	91.0	0.88	34.0	7.1	1.3		2.4							
				73.0	234	2970	91.5	0.91	127	7.6	1.1		2.7							
K21R	315 S	K20R	280 S ¹⁾	7.5	96.1	745	77.5	0.57	24.5	5.6	1.3		2.6	1.96	740					
	8-4-2L		8-4-2L	23.0	147	1490	91.0	0.88	41.5	8.6	1.4		2.7							
				88.0	282	2975	91.0	0.91	153	8.7	1.0		3.1							
K21R	315 M	K20R	280 M ¹⁾	8.5	109	745	79.0	0.56	27.5	5.7	1.4		2.7	2.27	840					
	8-4-2L		8-4-2L	27.0	174	1485	91.5	0.89	48.0	7.9	1.3		2.6							
				103	331	2975	91.5	0.92	177	8.4	1.0		2.9							
K21R	315 MX	K20R	315 S ¹⁾	10.0	128	745	79.5	0.57	32.0	5.7	1.3		2.6	2.73	1000					
	8-4-2L		8-4-2L	30.0	193	1485	91.0	0.89	53.5	7.5	1.3		2.5							
				110	353	2975	92.0	0.92	188	8.6	1.1		3.0							
K21R	315 MY	K20R	315 M ¹⁾	12.0	154	745	83.5	0.65	32.0	6.2	1.5		2.5	4.82	1200					
	8-4-2L		8-4-2L	35.0	224	1490	92.0	0.90	61.0	6.6	1.3		2.2							
				120	385	2980	93.0	0.93	200	8.0	1.0		2.7							
K21R	315 L	K20R	315 L ¹⁾	15.0	192	745	84.0	0.65	39.5	6.1	1.4		2.5	5.93	1450					
	8-4-2L		8-4-2L	42.0	269	1490	92.0	0.90	73.0	7.5	1.4		2.4							
				145	464	2985	93.0	0.93	242	9.3	1.2		3.0							

¹⁾ Provisional operating values

Three-phase motors with squirrel-cage rotor

Pole-changing, for constant load torque
with two separate windings in Δ -Y-YY configuration
with surface cooling, duty type S1, continuous duty
Thermal class 155, degree of protection IP 55, 50 Hz

Motor selection data													Design point 400 V, 50 Hz		
Type				P_B	M_B	n_B	η_B	$\cos\phi_B$	I_B	I_A/I_B	M_A/M_B	M_S/M_B	M_K/M_B	J	m
				kW	Nm	rpm	%	-	A	-	-	-	-	kgm ²	kg
Synchronous speed 750/1000/1500 rpm – 8-, 6- to 4-pole version															
K21R	100 LX 8-6-4	K20R	100 S 8-6-4	0.60	7.85	730	56.0	0.53	2.85	4.0		upon request		0.00900	28
				0.8	7.88	970	66.0	0.66	2.65	4.5	1.8	1.3	2.2		28.0 ¹⁾
				1.1	7.20	1460	72.0	0.82	2.65	6.5		upon request			
K21R	112 M 8-6-4	K20R	100 L 8-6-4	0.9	11.9	725	59.5	0.52	4.2	3.8	2.5	2.3	3.2	0.01225	33.5
				1.2	11.8	970	65.0	0.72	3.7	4.1	1.3	1.0	1.7		32.5 ¹⁾
				1.8	11.9	1450	78.0	0.85	3.9	6.1	1.6	1.5	2.2		
K21R	132 S 8-6-4	K20R	112 M 8-6-4	0.9	11.7	730	63.0	0.65	3.2	4.0	1.7	1.6	2.8	0.018	46
				1.1	10.8	970	71.0	0.75	3.0	4.0	1.2	1.1	2.5		
				1.4	9.16	1460	77.0	0.88	3.0	6.0	1.4	1.3	2.6		
K21R	132 M 8-6-4	K20R	112 MX 8-6-4	1.2	15.9	720	63.0	0.73	3.8	3.7	1.6	1.6	2.3	0.023	53
				1.5	14.8	970	70.0	0.76	4.1	4.0	1.3	1.2	2.5		
				2.0	13.2	1450	74.0	0.93	4.2	4.3	1.2	1.1	2.2		
K21R	132 MX 8-6-4	K20R	132 S 8-6-4	1.6	20.8	735	66.0	0.65	5.4	4.2	1.9	1.7	2.6	0.043	70
				2.1	20.5	980	76.0	0.75	5.3	5.0	1.5	1.3	2.6		
				2.8	18.3	1460	79.0	0.90	5.7	5.9	1.3	1.0	2.3		
K21R	160 M 8-6-4	K20R	132 M 8-6-4	2.3	30.1	730	71.0	0.67	7.0	4.4	1.9	1.7	2.7	0.053	86
				2.9	28.3	980	78.0	0.79	6.8	5.0	1.5	1.3	2.6		
				3.9	25.4	1465	80.0	0.90	7.8	6.0	1.3	1.0	2.3		
K21R	160 L 8-6-4	K20R	160 S 8-6-4	3.4	44.5	730	78.0	0.78	8.1	4.9	1.7	1.6	2.5	0.113	114
				4.0	39.0	980	80.0	0.84	8.6	5.1	1.2	1.1	2.1		
				5.8	37.9	1460	80.0	0.93	11.5	5.2	1.2	0.9	2.0		
K21R	180 L 8-6-4	K20R	160 M 8-6-4	4.8	62.8	730	78.0	0.79	11.0	4.7	1.6	1.4	2.1	0.145	138
				5.5	53.6	980	82.0	0.85	11.5	5.5	1.3	1.0	2.1		
				8.0	52.3	1460	80.0	0.93	15.5	4.8	1.2	0.7	1.8		
K21R	200 L 8-6-4	K20R	180 S 8-6-4	5.9	76.7	735	82.0	0.81	13.0	5.7	1.9	1.5	2.4	0.228	175
				6.6	64.0	985	85.0	0.84	13.5	6.3	1.6	1.3	2.5		
				9.0	58.5	1470	83.0	0.94	16.5	6.6	1.7	1.0	2.4		
K21R	200 LX 8-6-4	K20R	180 M 8-6-4	7.0	91.0	735	83.0	0.78	15.5	6.0	2.0	1.7	2.7	0.268	200
				7.9	76.6	985	86.0	0.82	16.0	7.1	1.8	1.4	3.0		
				11.0	71.5	1470	85.0	0.94	20.0	6.8	1.8	1.4	2.6		

¹⁾ Weights for K20R

Three-phase motors with squirrel-cage rotor

Pole-changing, for constant load torque
with two separate windings in Δ-Y-YY configuration
with surface cooling, duty type S1, continuous duty
Thermal class 155, degree of protection IP 55

Motor selection data													Design point 400 V, 50 Hz		
Type				P_B	M_B	n_B	η_B	$\cos\phi_B$	I_B	I_A/I_B	M_A/M_B	M_S/M_B	M_K/M_B	J	m
				kW	Nm	rpm	%	-	A	-	-	-	-	kgm ²	kg
Synchronous speed 750/1500/3000 rpm – 8-, 6- to 4-pole version															
K21R	225 M 8-6-4	K20R	200 M	9.5	132	735	85.0	0.79	20.5	6.8	2.2	1.8	2.6	0.443	265
			8-6-4	10.5	102	985	87.0	0.83	21.0	7.3	2.0	1.6	3.0		
				15.0	97.1	1475	86.0	0.92	27.5	7.6	2.1	1.1	2.7		
K21R	250 M 8-6-4	K20R	225 M	11.5	148	740	85.0	0.79	24.5	7.1	2.4	1.8	2.8	0.825	360
			8-6-4	13.0	125	990	89.0	0.84	25.0	8.2	2.2	1.8	3.1		
				18.5	119	1480	86.0	0.92	33.5	8.1	2.2	1.2	2.6		
K21R	280 S 8-6-4	K20R	250 S	14.0	181	740	88.0	0.80	28.5	6.5	2.2	1.6	2.4	1.28	465
			8-6-4	16.0	154	992	89.0	0.84	31.0	7.4	1.9	1.3	2.7		
				20.0	129	1483	86.0	0.92	36.5	7.9	2.0	1.0	2.5		
K21R	280 M 8-6-4	K20R	250 M	17.0	219	742	88.0	0.77	36.0	7.3	2.6	2.0	2.9	1.48	520
			8-6-4	20.0	193	990	89.0	0.84	38.5	7.7	2.2	1.4	2.9		
				25.0	161	1485	87.0	0.92	45.0	9.8	2.6	1.4	3.0		
K21R	315 S 8-6-4	K20R	280 S	24.0	308	744	88.0	0.77	51.0	7.0	2.2	1.9	2.8	2.63	690
			8-6-4	27.0	260	992	91.0	0.80	53.5	8.0	1.9	1.6	3.2		
				37.0	238	1487	89.0	0.92	65.0	8.5	1.9	1.4	2.8		
K21R	315 M 8-6-4	K20R	280 M	30.0	386	742	89.0	0.79	61.5	6.5	1.8	1.6	2.4	3.33	800
			8-6-4	36.0	347	992	91.5	0.84	67.5	6.5	1.4	1.2	2.4		
				45.0	289	1485	89.0	0.92	79.5	7.5	1.6	1.1	2.4		
K21R	315 MX 8-6-4	K20R	315 S	45.0	580	741	90.5	0.80	89.5	7.0	2.2	1.7	2.4	3.6	880
			8-6-4	55.0	531	990	91.8	0.86	101	6.0	1.2	1.0	2.1		
				68.0	437	1485	91.0	0.93	116	8.0	2.0	1.4	2.4		
K21R	315 MY 8-6-4	K20R	315 M	55.0	707	743	92.6	0.80	107	7.5	2.2	1.9	2.6	6	1050
			8-6-4	68.0	655	992	93.4	0.86	122	7.0	1.7	1.3	2.6		
				80.0	513	1488	92.3	0.92	136	8.5	2.2	1.5	2.7		

Three-phase motors with squirrel-cage rotor

Pole-changing, for quadratically increasing load torque
 Fan drives, with two separate windings in Y-Y-YY configuration
 with surface cooling, duty type S1, continuous duty
 Thermal class 155, degree of protection IP 55, 50 Hz

Motor selection data														Design point 400 V, 50 Hz	
Type		P_B	M_B	n_B	η_B	$\cos\phi_B$	I_B	I_A/I_B	M_A/M_B	M_S/M_B	M_K/M_B	J	m		
		kW	Nm	rpm	%	-	A	-	-	-	-	kgm ²	kg		
Synchronous speed 750/1000/1500 rpm – 8-, 6- to 4-pole version															
K21R	80 K	K20R	71 K	0.05	0.67	715	32.0	0.71	0.32	2.0	1.2	1.2	1.8	0.00130	11.0
	8-6-4L		8-6-4L	0.06	0.59	970	46.0	0.63	0.3	2.8	1.6	1.6	2.4	10.0 ¹⁾	
				0.21	1.38	1450	58.0	0.76	0.69	3.6	1.1	1.1	1.8		
K21R	80 G	K20R	71 G	0.09	1.25	690	38.0	0.68	0.5	2.1	1.3	1.3	1.8	0.00175	12.5
	8-6-4L		8-6-4L	0.12	1.21	945	52.0	0.72	0.46	2.8	1.3	1.2	1.8	11.5 ¹⁾	
				0.37	2.47	1430	62.0	0.76	1.12	3.7	1.1	1.1	1.9		
K21R	90 S	K20R	80 K	0.15	2.00	715	49.0	0.59	0.74	2.4	1.4	1.4	2.0	0.00325	16.0
	8-6-4L HL		8-6-4L HL	0.22	2.18	965	50.0	0.70	0.9	3.0	1.2	1.2	1.9	15.0 ¹⁾	
				0.7	4.67	1430	67.0	0.80	1.87	4.0	1.2	1.2	1.6		
K21R	90 L	K20R	80 G	0.22	2.98	705	55.0	0.63	0.92	2.7	1.4	1.4	2.0	0.00425	19.0
	8-6-4L HL		8-6-4L HL	0.3	2.97	965	55.0	0.71	1.11	3.2	1.2	1.2	2.0	18.0 ¹⁾	
				0.95	6.37	1425	71.0	0.82	2.36	4.4	1.2	1.2	2.0		
K21R	100 L	K20R	90 L	0.37	4.94	715	60.0	0.61	1.45	2.8	1.4	1.3	1.7	0.00625	24.0
	8-6-4L HL		8-6-4L HL	0.55	5.41	970	62.0	0.71	1.8	3.0	1.2	1.1	1.7	24.0 ¹⁾	
				1.5	9.91	1445	70.0	0.81	3.8	4.7	1.2	1.1	1.8		
K21R	100 LX	K20R	100 S	0.45	6.01	715	65.0	0.64	1.55	3.5	1.4	1.4	2.1	0.00900	28.0
	8-6-4L HL		8-6-4L HL	0.7	6.89	970	63.0	0.71	2.26	4.2	1.2	1.1	2.0	28.0 ¹⁾	
				1.9	12.6	1435	69.0	0.84	4.7	4.8	1.1	1.1	1.9		
K21R	112 M	K20R	100 L	0.75	10.1	710	66.0	0.68	2.4	3.6	1.6	1.6	2.2	0.01225	33.5
	8-6-4L HL		8-6-4L HL	1.1	10.9	965	63.0	0.80	3.35	3.7	1.1	1.1	1.7	32.5 ¹⁾	
				2.6	17.2	1440	66.5	0.85	6.6	5.0	1.4	1.4	2.7		
K21R	132 S	K20R	112 M	0.75	9.88	725	65.0	0.70	2.4	3.9	1.4		2.5	0.018	46
	8-6-4L		8-6-4L	1.1	10.7	980	63.0	0.66	3.8	4.6	1.4		2.9		
				3.0	19.7	1458	73.1	0.85	7.0	5.0	1.2		2.2		
K21R	132 M	K20R	112 MX	1.0	13.2	725	67.0	0.68	3.2	4.6	1.7		2.8	0.023	53
	8-6-4L		8-6-4L	1.4	13.6	980	68.5	0.75	3.9	4.9	1.4		2.8		
				4.0	26.3	1455	69.0	0.85	9.8	6.1	1.7		2.7		
K21R	132 MX	K20R	132 S	1.2	15.7	730	77.3	0.68	3.3	4.7	1.6		2.9	0.043	70
	8-6-4L		8-6-4L	1.7	16.5	983	68.8	0.71	5.0	4.7	1.1		2.6		
				5.0	32.6	1463	79.8	0.88	10.5	6.0	1.5		3.0		
K21R	160 M	K20R	132 M	1.9	25.1	723	79.0	0.75	4.6	4.3	1.4		2.4	0.053	86
	8-6-4L		8-6-4L	2.5	24.3	983	70.0	0.70	7.4	4.9	1.4		2.8		
				7.5	49.3	1453	80.0	0.90	15.0	5.7	1.6		2.7		
K21R	160 L	K20R	160 S	2.5	32.8	729	83.0	0.80	5.4	5.8	2.2		2.6	0.113	114
	8-6-4L		8-6-4L	4.0	38.8	984	76.0	0.77	9.9	5.3	1.3		2.7		
				11.0	72.4	1450	83.0	0.92	21.0	5.7	1.8		2.5		
K21R	180 L	K20R	160 M	3.5	56.3	722	83.0	0.84	7.2	4.9	1.8		2.1	0.145	138
	8-6-4L		8-6-4L	5.0	48.5	985	74.0	0.76	13.0	5.4	1.2		2.6		
				14.0	92.8	1441	83.0	0.94	26.0	5.3	1.8		2.3		

¹⁾ Weights for K20R

Three-phase motors with squirrel-cage rotor

Pole-changing, for quadratically increasing load torque
 Fan drives, with two separate windings Y-Y-YY configuration
 with surface cooling, duty type S1, continuous duty
 Thermal class 155, degree of protection IP 55, 50 Hz

Motor selection data													Design point 400 V, 50 Hz			
Type				P_B	M_B	n_B	η_B	$\cos\phi_B$	I_B	I_A/I_B	M_A/M_B	M_S/M_B	M_K/M_B	J	m	
				kW	Nm	rpm	%	-	A	-	-	-	-	kgm ²	kg	
Synchronous speed 750/1000/1500 rpm – 8-, 6- to 4-pole version																
K21R	200 L	K20R	180 S	4.0	52.0	735	84.0	0.78	8.8	6.0	2.1		2.8	0.228	175	
	8-6-4L		8-6-4L	6.5	63.0	985	80.0	0.82	14.5	6.0	1.5		2.7			
K21R	200 LX	K20R	180 M	5.5	71.5	735	86.0	0.80	11.5	5.1	1.4		2.6	0.268	200	
			8-6-4L	8-6-4L	7.5	72.4	990	76.0	0.78	18.5	6.1	1.4				2.8
					22.0	144	1460	84.0	0.90	42.0	6.1	1.7				2.9
K21R	225 M	K20R	200 M	7.0	91.0	735	86.5	0.82	14.0	6.2	1.7		3.2	0.443	265	
	8-6-4L		8-6-4L	10.0	97.0	985	81.5	0.83	21.5	6.8	1.5		2.9			
				30.0	196	1460	86.0	0.92	54.5	7.1	1.8		3.5			
K21R	250 M	K20R	225 M	8.0	103	738	88.0	0.81	16.0	5.7	1.5		2.7	0.825	360	
	8-6-4L		8-6-4L	12.0	116	988	84.0	0.85	24.5	6.6	1.4		2.6			
				35.0	227	1472	87.0	0.93	62.5	6.5	1.7		3.0			
K21R	280 S	K20R	250 S	10.0	129	740	89.0	0.81	20.0	5.7	2.0		2.4	1.28	465	
	8-6-4L		8-6-4L	15.0	145	990	88.0	0.85	29.0	6.5	1.6		2.6			
				44.0	285	1475	89.0	0.92	78.0	7.0	2.0		2.5			
K21R	280 M	K20R	250 M	16.0	206	740	90.0	0.82	31.5	5.6	1.6		2.6	1.48	520	
	8-6-4L		8-6-4L	22.0	212	993	86.0	0.81	45.5	6.8	1.5		2.8			
				65.0	421	1475	88.0	0.90	118	6.9	1.9		3.2			
K21R	315 S	K20R	280 S	18.0	231	744	91.5	0.77	37.0	5.6	1.6		2.3	2.63	690	
	8-6-4L		8-6-4L	28.0	689	995	85.5	0.79	59.5	7.4	1.5		2.9			
				80.0	515	1485	90.5	0.90	142	6.9	1.9		2.7			
K21R	315 M	K20R	280 M	23.0	295	745	92.5	0.79	45.5	7.0	1.8		2.5	3.33	800	
	8-6-4L		8-6-4L	35.0	336	995	87.5	0.83	69.5	8.5	1.6		3.0			
				100	643	1485	91.5	0.90	175	9.2	2.0		2.9			
K21R	315 MX	K20R	315 S	25.0	323	740	90.0	0.82	49.0	5.5	1.5		1.9	3.6	880	
	8-6-4L		8-6-4L	35.0	336	995	87.5	0.84	69.0	7.0	1.2		2.3			
				100	645	1480	91.5	0.92	171	8.5	2.0		2.4			
K21R	315 MY	K20R	315 M	28.0	360	742	92.6	0.83	52.5	5.8	1.4		2.3	6	1050	
	8-6-4L		8-6-4L	42.0	404	992	88.6	0.87	78.5	6.8	1.4		2.4			
				110	709	1482	92.3	0.93	185	7.1	1.4		2.4			

Three-phase motors with squirrel-cage rotor

Pole-changing, for constant load torque
with two separate windings Δ - Δ -YY-YY configuration
with surface cooling, duty type S1, continuous duty
Klasse 155, degree of protection IP 55, 50 Hz

Motor selection data													Design point 400 V, 50 Hz							
Type				P_B	M_B	n_B	η_B	$\cos\phi_B$	I_B	I_A/I_B	M_A/M_B	M_S/M_B	M_K/M_B	J	m					
									400 V											
									kW	Nm	rpm	%	-	A	-	-	-	-	kgm ²	kg
Synchronous speed 500/750/1000/1500 rpm – 12-, 8-, 6- to 4-pole version																				
K21R	160 L	K20R	160 S	1.9	37.8	480	64.0	0.70	6.1	2.9	1.4	1.3	1.7	0.113	114					
12-8-6-4		12-8-6-4		2.5	32.5	735	76.0	0.74	6.4	4.5	1.4	1.3	2.3							
				3.0	29.4	975	76.0	0.89	6.4	4.5	1.1	1.0	1.9							
				3.7	24.0	1475	81.0	0.92	7.2	6.2	1.2	0.9	2.3							
K21R	180 L	K20R	160 M	2.6	51.7	480	66.0	0.70	8.1	3.2	1.5	1.3	1.7	0.145	138					
12-8-6-4		12-8-6-4		3.6	46.8	735	79.0	0.76	8.7	4.8	1.5	1.4	2.1							
				4.0	39.2	975	78.0	0.90	8.2	4.8	1.3	1.0	1.9							
				5.4	35.0	1475	82.0	0.92	10.5	6.0	1.5	0.9	2.2							
K21R	200 L	K20R	180 S	3.2	63.0	485	75.0	0.66	9.3	4.0	2.0	1.8	2.4	0.228	175					
12-8-6-4		12-8-6-4		4.2	54.2	740	80.0	0.74	10.0	5.8	1.8	1.5	2.8							
				5.0	48.7	980	83.0	0.89	9.8	6.3	1.8	1.3	2.4							
				6.5	41.9	1480	82.0	0.91	12.5	7.4	1.6	0.9	3.0							
K21R	200 LX	K20R	180 M	3.8	74.1	490	75.0	0.64	11.5	4.3	1.9	1.6	2.3	0.268	200					
12-8-6-4		12-8-6-4		5.0	64.5	740	81.0	0.72	12.5	5.9	1.8	1.6	2.9							
				5.9	57.2	985	83.0	0.87	12.0	6.6	1.8	1.5	2.6							
				7.7	49.7	1480	84.0	0.90	14.5	7.6	1.7	1.1	2.8							
K21R	225 M	K20R	200 M	5.2	101	490	78.0	0.64	15.0	4.7	2.1	1.9	2.5	0.443	265					
12-8-6-4		12-8-6-4		6.9	89.1	740	84.0	0.76	15.5	6.0	1.6	1.4	2.6							
				8.1	78.5	985	86.0	0.88	15.5	7.3	1.9	1.4	2.8							
				10.5	67.8	1480	85.0	0.92	19.5	7.3	1.5	0.7	2.5							
K21R	250 M	K20R	225 M	6.5	127	490	81.0	0.67	17.5	4.2	1.7	1.4	1.7	0.825	360					
12-8-6-4		12-8-6-4		8.5	110	740	85.0	0.77	18.5	5.8	1.7	1.4	2.2							
				10.0	97.5	980	85.0	0.88	19.5	6.3	1.8	1.2	2.1							
				13.0	83.9	1480	85.0	0.92	24.0	7.0	1.5	0.7	2.2							
K21R	280 S	K20R	250 S	7.8	151	492	82.0	0.65	21.0	4.6	2.1	1.6	2.1	1.28	465					
12-8-6-4		12-8-6-4		10.0	128	745	86.0	0.74	22.5	6.4	2.0	1.5	2.7							
				12.0	116	990	86.0	0.88	23.0	6.8	2.0	1.4	2.4							
				15.5	99.5	1488	85.0	0.91	29.0	7.9	1.9	0.9	2.6							
K21R	280 M	K20R	250 M	9.6	186	493	82.0	0.65	26.0	4.4	2.1	1.7	2.2	1.48	520					
12-8-6-4		12-8-6-4		12.5	161	743	86.0	0.75	28.0	6.3	2.1	1.5	2.7							
				15.0	145	990	87.0	0.89	28.0	7.2	2.1	1.4	2.3							
				19.0	122	1488	85.0	0.92	35.0	8.1	1.9	0.9	2.7							
K21R	315 S	K20R	280 s	13.0	251	495	84.0	0.62	36.0	4.9	1.8	1.6	2.2	2.630	690					
12-8-6-4		12-8-6-4		17.0	218	744	89.0	0.74	37.5	6.5	1.4	1.3	2.5							
				20.0	193	991	89.0	0.87	37.5	7.5	1.7	1.4	2.4							
				26.0	167	1488	86.0	0.91	48.0	8.0	1.2	0.8	2.5							
K21R	315 M	K20R	280 M	18.0	348	494	84.0	0.64	48.5	4.4	1.6	1.4	2.0	3.33	800					
12-8-6-4		12-8-6-4		22.0	282	745	90.0	0.74	47.5	6.3	1.3	1.2	2.5							
				26.0	250	992	90.0	0.87	48.0	7.5	1.8	1.4	2.4							
				32.0	205	1490	90.0	0.91	56.5	8.1	1.4	0.9	2.5							
K21R	315 MX	K20R	315 S	26.0	504	493	85.0	0.66	67.0	4.5	1.5	1.4	1.8	3.60	880					
12-8-6-4		12-8-6-4		32.0	411	744	89.0	0.75	69.0	6.0	1.3	1.2	2.2							
				38.0	366	991	90.0	0.88	69.5	7.0	1.6	1.2	2.1							
				45.0	288	1490	90.0	0.92	78.5	7.5	1.3	0.7	2.5							
K21R	315 MY	K20R	315 M	32.0	624	490	87.0	0.70	76.0	4.3	1.4	1.1	1.6	6.00	1050					
12-8-6-4		12-8-6-4		38.0	487	745	92.4	0.76	78.0	6.5	1.8	1.6	2.5							
				45.0	434	990	91.4	0.89	80.0	7.0	1.6	1.5	2.1							
				55.0	352	1491	92.5	0.92	93.5	8.5	1.6	1.4	2.8							

Bearings

Series IE3-W4.R Standard version

Type	Anti-friction bearing	D-end				N-end			Figure		Fixed bearing	
		V-ring	γ-ring	Wave spring	Disc spring	Anti-friction bearing	V-ring	γ-ring	Wave spring	NS		DS
IE3-W41R 56 G2	6201 2Z C3	-	-	-	-	6201 2Z C3	-	-	32	1	2	without
IE3-W42R 63 K2, 4	6201 2Z C3	-	-	-	-	6201 2Z C3	-	-	32	1	2	without
IE3-W41R 63 G2, 4, 6	6202 2Z C3	-	-	-	-	6202 2Z C3	-	-	35	1	2	without
IE3-W42R 71 K2, 4, KY6	6202 2Z C3	-	-	-	-	6202 2Z C3	-	-	35	1	2	without
IE3-W41R 71 GY2, 4, 6, G8	6204 2Z C3	-	-	-	-	6204 2Z C3	-	-	47	1	2	without
IE3-W42R 80 K2, 8	6204 2Z C3	-	-	-	-	6204 2Z C3	-	-	47	1	2	without
IE3-W41R 80 K2, 4, 6, GY2	6205 2Z C3	-	-	-	-	6205 2Z C3	-	-	52	1	2	without
IE3-W41R 80 G2, 4, 6, GY4	6205 2Z C3	-	-	-	-	6205 2Z C3	-	-	52	1	2	without
IE3-W42R 90 S2, SY8	6205 2Z C3	-	-	-	-	6205 2Z C3	-	-	52	1	2	without
IE3-W41R 90 S2, 8, SY4, 6	6205 2Z C3	-	-	-	-	6205 2Z C3	-	-	52	1	2	without
IE3-W41R 90 LY2	6205 2Z C3	-	-	-	-	6205 2Z C3	-	-	52	1	2	without
IE3-W41R 90 S4, 6	6205 2Z C3	-	-	-	-	6205 2Z C3	-	-	52	1	2	without
IE3-W41R 90 L2, 4, 6, 8	6205 2Z C3	-	-	-	-	6205 2Z C3	-	-	52	1	2	without
IE3-W41R 90 LX4	6205 2Z C3	-	-	-	-	6205 2Z C3	-	-	52	1	2	without
IE3-W41R 100 L8, LY2, 8	6206 2Z C3	-	-	-	-	6206 2Z C3	-	-	62	1	2	without
IE3-W41R 100 LY4	6206 2Z C3	-	-	-	-	6206 2Z C3	-	-	62	1	2	without
IE3-W41R 100 L2	6206 2Z C3	-	-	-	-	6206 2ZN C3	-	-	62	1	2	without
IE3-W41R 100 LW8, LX6, 8	6206 2ZN C3	-	-	-	-	6206 2ZN C3	-	-	62	1	2	without
IE3-W41R 100 L4, LX4	6206 2Z C3	-	-	-	-	6206 2ZN C3	-	-	62	1	2	without
IE3-W41R 100 LW4, LZ4	6206 2Z C3	-	-	-	-	6206 2ZN C3	-	-	62	1	2	without
IE3-W41R 112 MY2	6206 2Z C3	-	-	-	-	6206 2ZN C3	-	-	62	1	2	without
IE3-W41R 112 M2, 8, MV6	6206 2Z C3	-	-	-	-	6206 2ZN C3	-	-	62	1	2	without
IE3-W41R 112 MZ6, 8	6206 2ZN C3	-	-	-	-	6206 2ZN C3	-	-	62	1	2	without
IE3-W41R 112 M4	6207 2ZN C3	-	-	-	-	6207 2ZN C3	-	-	72	1	2	without
IE3-W41R 112 MW4, W40R 112 M2	6207 2ZN C3	-	-	-	-	6207 2ZN C3	-	-	72	1	2	without
IE3-W41R 132 S2T	6208 2ZN C3	-	-	80	-	6206 2Z C3	-	-	-	3	5	without
IE3-W41R 132 S2	6208 2ZN C3	-	-	80	-	6207 2ZN C3	-	-	-	3	5	without
IE3-W41R 132 S6	6208 2ZN C3	-	-	80	-	6207 2ZN C3	-	-	-	3	5	without
IE3-W41R 132 SX2, 6; S4, 8; M4, 6, 8	6308 ZZ C3	-	RB40	90	-	6308 ZZ C3	-	RB40	-	6	8	N-end
IE3-W41R 160 M2, 4, 6, 8; MX2, 8	6310 ZZ C3	-	RB50	110	-	6309 ZZ C3	-	RB45	-	6	8	N-end
IE3-W41R 160 L2, 8; L4C, L6C	6310 ZZ C3	-	RB50	110	-	6309 ZZ C3	-	RB45	-	6	8	N-end
IE3-W41R 180 M2C, M4, L4, L6C, L8	6310 C3	50A	-	110	-	6310 C3	50A	-	-	6	8	N-end
IE3-W41R 200 L2; LX2C, LX6C, L4C, L6	6312 C3	60A	-	-	130	6312 C3	60A	-	-	6	8	N-end
IE3-W41R 200 L8	6310 C3	50A	-	110	-	6310 C3	50A	-	-	6	8	N-end
IE3-W41R 225 M2	6313 C3	65A	-	-	140	6313 C3	65A	-	-	6	8	N-end
IE3-W41R 225 S4C	6313 C3	65A	-	-	140	6312 C3	60A	-	-	6	8	N-end
IE3-W41R 225 M4, 6, 8	6314 C3	70A	-	-	150	^{6313 C3}	65A	-	-	6	8	N-end
IE3-W41R 225 S8	6312 C3	60A	-	-	130	6312 C3	60A	-	-	6	8	N-end
IE3-W41R 250 M2	6314 C3	70A	-	-	150	6314 C3	70A	-	-	6	8	N-end
IE3-W41R 250 M4, 6	6316 C3	80A	-	-	170	6314 C3	70A	-	-	6	8	N-end
IE3-W41R 250 M8	6314 C3	70A	-	-	150	6313 C3	65A	-	-	6	8	N-end
IE3-W41R 280 S2, M2	6314 C3	70A	-	-	150	6314 C3	70A	-	-	6	8	N-end
IE3-W41R 280 S4, 8	6316 C3	80A	-	-	170	6314 C3	70A	-	-	6	8	N-end
IE3-W41R 280 M4, 6, 8; S6	6317 C3	85A	-	-	180	6316 C3	80A	-	-	6	8	N-end
IE3-W41R 315 S2, M2	6316 C3	80A	-	-	170	6316 C3	80A	-	-	6	8	N-end
IE3-W41R 315 MX2, MY2, L2, LX2	6317 C3	85A	-	-	180	6317 C3(1)	85A	-	-	6	8	N-end
IE3-W41R 315 S4, M4	6317 C3	85A	-	-	180	6316 C3	80A	-	-	6	8	N-end
IE3-W41R 315 S6; M6, 8; MX4, 6, 8	6320 C3	-	RB100	-	215	6317 C3(1)	85A	-	-	18	19	N-end
IE3-W41R 315 MY4, 6, 8; L4, 8; LX4	6320 C3	-	RB100	-	215	6317 C3(1)	85A	-	-	18	19	N-end
IE3-W41R 315 S8	6317 C3	85A	-	-	180	6316 C3	80A	-	-	18	19	N-end
IE3-W41R 355 M2	6317 C3	-	RB85A	-	180	6317 C3(1)	85A	-	-	18	19	N-end
IE3-W41R 355 M4, 6, 8	6324 C3	-	RB120	-	260	6317 C3(1)	85A	-	-	18	19	N-end

¹⁾ For types for vertical mounting Q317 C3; figures 18, 21
 IE3-W41R from 2-pole 315 MX, 4-pole 315 MX, 6-pole 315 S with relubrication device as standard
 IE3-W41R 315 M8, MX8, MY8, L8; IE3-W41R 355 M8 with relubrication device as standard

Series IE3-W41R Reinforced Bearings

Type	Anti-friction bearing	D-end		Anti-friction bearing	N-end		Figure		Fixed bearing
		V-ring	γ-ring		V-ring	γ-ring	DS	NS	
IE3-W41R 132 SX2	NU 308 E	-	RB40	6308 ZZ C3	-	RB40	7	9	N-end
IE3-W41R 132 M6; MX6	NU 308 E	-	RB45	6308 ZZ C3	-	RB40	7	9	N-end
IE3-W41R 132 S8; M8	NU 308 E	-	RBRB45	6308 ZZ C3	-	RB40	7	9	N-end
IE3-W41R 160 M2, 4, 6, 8; MX2, 8	NU 310 E	-	RB50	6309 ZZ C3	-	RB45	7	9	N-end
IE3-W41R 160 L2, 8; L4C, L6C	NU 310 E	-	RB50	6309 ZZ C3	-	RB45	7	9	N-end
IE3-W41R 180 M2C, M4, L6C; L4, 8	NU 310 E	50A	-	6310 C3	50A	-	7	9	N-end
IE3-W41R 200 L2, 6; LX2C; LX6C, L4C	NU 312 E	60A	-	6312 C3	60A	-	7	9	N-end
IE3-W41R 200 L8	NU 310 E	50A	-	6310 C3	50A	-	7	9	N-end
IE3-W41R 225 M2	NU 313 E	65A	-	6313 C3	60A	-	7	9	N-end
IE3-W41R 225 S4C	NU 313 E	65A	-	6312 C3	60A	-	7	9	N-end
IE3-W41R 225 M4, 6, 8	NU 314 E	70A	-	6313 C3	65A	-	7	9	N-end
IE3-W41R 225 S8	NU 312 E	60A	-	6312 C3	60A	-	7	9	N-end
IE3-W41R 250 M2	NU 314 E	70A	-	6314 C3	70A	-	7	9	N-end
IE3-W41R 250 M4, 6	NU 316 E	80A	-	6314 C3	70A	-	7	9	N-end
IE3-W41R 250 M8	NU 314 E	70A	-	6313 C3	65A	-	7	9	N-end
IE3-W41R 280 S2, M2	NU 314 E	70A	-	6314 C3	70A	-	7	9	N-end
IE3-W41R 280 S4, 8	NU 316 E	80A	-	6314 C3	70A	-	7	9	N-end
IE3-W41R 280 S6, M4, 6, 8	NU 317 E	85A	-	6316 C3	80A	-	7	9	N-end
IE3-W41R 315 S2, M2	NU 316 E	80A	-	6316 C3	80A	-	7	9	N-end
IE3-W41R 315 MX2, MY2, L2, LX2	NU 317 E	85A	-	6317 C31)	85A	-	7	9	N-end
IE3-W41R 315 S4, M4	NU 317 E	85A	-	6316 C3	80A	-	7	9	N-end
IE3-W41R 315 L4, 8; LX4, S6	NU 320 E	-	RB100	6317 C31)	85A	-	20	19	N-end
IE3-W41R 315 M6, 8; MX4, 6, 8; MY4, 6, 8	NU 320 E	-	RB100	6317 C31)	85A	-	20	19	N-end
IE3-W41R 315 S8	NU 317 E	85A	-	6316 C3	80A	-	20	19	N-end
IE3-W41R 355 M2	NU 317 E	-	RB85	6317 C31)	85A	-	20	19	N-end
IE3-W41R 355 M4, 6, 8	NU 324 E	-	RB120	6317 C31)	85A	-	20	19	N-end

¹⁾ For types for vertical mounting Q317 C3; figures 18, 21

IE3-W41R from 2-pole 315 MX, 4-pole 315 MX, 6-pole 315 S with relubrication device as standard

IE3-W41R 315 M8, MX8, MY8, L8; IE3-W41R 355 M8 with relubrication device as standard

Series IE3-W41R Relubrication device

Type	D-end						N-end		Figure				Fixed bearing	
	Anti-friction bearing						Anti-friction bearing		DS	NS	DS	NS		
	Light-duty bearings	Reinforced bearings	V-ring	γ-ring	Wave spring ¹⁾	Disc spring ¹⁾	V-ring	γ-ring	Light-duty bearings	Light-duty bearings	Reinforced bearings	Reinforced bearings		
IE3-W41R 132 SX2, MX6	6308 C3	NU 308	-	RB40	90	-	6308 C3	-	RB40	13	14	15	14	N-end
IE3-W41R 160 M2, 4, 8	6310 C3	NU 310 E	-	RB50	110	-	6309 C3	-	RB45	13	14	15	14	N-end
IE3-W41R 160 MX2, 8; L2, 8; L4C	6310 C3	NU 310 E	-	RB50	110	-	6309 C3	-	RB45	13	14	15	14	N-end
IE3-W41R 160 M6	6310 C3	NU 310 E	-	50	110	-	6309 C3	-	RB45	13	14	15	14	N-end
IE3-W41R 160 L6C	6310 C3	NU 310 E	-	50	110	-	6309 C3	-	RB45	13	14	15	14	N-end
IE3-W41R 180 M2C; M4; L4, 8; L6C	6310 C3	NU 310 E	-	RB50	110	-	6310 C3	50A	-	13	14	15	14	N-end
IE3-W41R 200 L2, 6; LX2C, LX6C; L4C	6312 C3	NU 312 E	-	RB60	-	130	6312 C3	60A	-	13	14	15	14	N-end
IE3-W41R 200 L8	6310 C3	NU 310 E	-	RB50	110	-	6310 C3	50A	-	13	14	15	14	N-end
IE3-W41R 225 M2	6313 C3	NU 313 E	-	RB65	-	140	6313 C3	65A	-	13	14	15	14	N-end
IE3-W41R 225 S4C	6313 C3	NU 313 E	-	RB65	-	140	6312 C3	60A	-	13	14	15	14	N-end
IE3-W41R 225 M4, 6, 8	6314 C3	NU 314 E	-	RB70	-	150	6313 C3	65A	-	13	14	15	14	N-end
IE3-W41R 225 S8	6312 C3	NU 312 E	-	RB60	-	130	6312 C3	60A	-	13	14	15	14	N-end
IE3-W41R 250 M2	6314 C3	NU 314 E	-	RB70	-	150	6314 C3	70A	-	13	14	15	14	N-end
IE3-W41R 250 M4, 6	6316 C3	NU 316 E	-	RB80	-	170	6314 C3	70A	-	13	14	15	14	N-end
IE3-W41R 250 M8	6314 C3	NU 314 E	-	RB70	-	150	6313 C3	65A	-	13	14	15	14	N-end
IE3-W41R 280 S2, M2	6314 C3	NU 314 E	-	RB70	-	150	6314 C3	70A	-	13	14	15	14	N-end
IE3-W41R 280 S4, 8	6316 C3	NU 316 E	-	RB80	-	170	6314 C3	70A	-	13	14	15	14	N-end
IE3-W41R 280 M4, 6, 8; S6	6317 C3	NU 317 E	-	RB85	-	180	6316 C3	80A	-	13	14	15	14	N-end
IE3-W41R 315 S2, M2	6316 C3	NU 316 E	-	RB80	-	170	6316 C3	80A	-	13	14	15	14	N-end
IE3-W41R 315 S4, 8; M4	6317 C3	NU 317 E	-	RB85	-	180	6316 C3	80A	-	13	14	15	14	N-end
IE3-W41R 315 L2, 4, 8; LX2, 4							see basic version							
IE3-W41R 315 M6, 8; MX2, 4, 6, 8; MY2, 4, 6, 8							see basic version							
IE3-W41R 355 M2, 4, 6, 8; S6							see basic version							

¹⁾ Light-duty bearings only

Series IE2-W..R Standard version

Type	Anti-friction bearing	D-end					Anti-friction bearing	N-end				Figure		Fixed bearing
		Felt ring	V-ring	γ-ring	Wave spring	Disc spring		Felt ring	V-ring	γ-ring	Wave spring	DS	NS	
IE2-W21R 56 K2, 4, G2, 4, WE2R 56 G2	6201 2Z C3	11 x 19 x 4	-	-	-	-	6201 2Z C3	12 x 25 x 1	-	-	32	1	2	without
IE2-WE2R 63 K2, 4, G2, 6	6201 2Z C3	11 x 19 x 4	-	-	-	-	6201 2Z C3	12 x 25 x 1	-	-	32	1	2	without
IE2-W21R 63 K2, 4, G2, 4, WE1R 63 GY4	6202 2Z C3	14 x 21 x 4	-	-	-	-	6202 2Z C3	15 x 28 x 1	-	-	35	1	2	without
IE2-WE2R 71 K2, 4, 6, G2, 6, 8	6202 2Z C3	14 x 21 x 4	-	-	-	-	6202 2Z C3	15 x 28 x 1	-	-	35	1	2	without
IE2-W21R 71 K2, 4, 6, G2, 4, 6, WE1R 71 GY4	6204 2Z C3	19 x 26 x 4	-	-	-	-	6204 2Z C3	20 x 36 x 2	-	-	47	1	2	without
IE2-WE2R 80 K2, 4, 6, 8, G2, 8	6204 2Z C3	19 x 26 x 4	-	-	-	-	6204 2Z C3	20 x 36 x 2	-	-	47	1	2	without
IE2-W21R 80 K2, 4, 6, 8, WE1R 80 GY4, 6	6205 2Z C3	24.2 x 35 x 4	-	-	-	-	6205 2Z C3	25 x 40 x 2	-	-	52	1	2	without
IE2-WE(2)1R 80 G2, 4, 6	6205 2Z C3	24.2 x 35 x 4	-	-	-	-	6205 2Z C3	25 x 40 x 2	-	-	52	1	2	without
IE2-WE2R 90 S2, 8	6205 2Z C3	24 x 35 x 4	-	-	-	-	6205 2Z C3	25 x 40 x 2	-	-	52	1	2	without
IE2-WE2R 90 S4, 6	6205 2Z C3	24 x 35 x 4	-	-	-	-	6205 2Z C3	25 x 40 x 2	-	-	52	1	2	without
IE2-WE2R 90 L2, 8	6205 2Z C3	24 x 35 x 4	-	-	-	-	6205 2Z C3	25 x 40 x 2	-	-	52	1	2	without
IE2-WE(2)1R 90 S2, 4, 6, 8	6205 2Z C3	24.2 x 35 x 4	-	-	-	-	6205 2Z C3	25 x 40 x 2	-	-	52	1	2	without
IE2-WE1R 90 L2, LW4, 6	6205 2Z C3	24.2 x 35 x 4	-	-	-	-	6205 2Z C3	25 x 40 x 2	-	-	52	1	2	without
IE2-WE(2)1R 90 L4, 6, 8	6205 2Z C3	24.2 x 35 x 4	-	-	-	-	6205 2Z C3	25 x 40 x 2	-	-	52	1	2	without
IE2-WE2R 100 L8	6206 2Z C3	29 x 40 x 4	-	-	-	-	6205 2Z C3	25 x 40 x 2	-	-	52	1	2	without
IE2-WE2R 100 L6, LY2	6206 2Z C3	29 x 40 x 4	-	-	-	-	6205 2Z C3	25 x 40 x 2	-	-	52	1	2	without
IE2-WE(2)1R 100 L2, 8, S4, LY8	6206 2Z C3	29 x 40 x 4	-	-	-	-	6206 2Z C3	30 x 50 x 2	-	-	62	1	2	without
IE2-WE1R 100 LX4	6206 2Z C3	29 x 40 x 4	-	-	-	-	6206 2Z C3	30 x 50 x 2	-	-	62	1	2	without
IE2-WE1R 100 L4, LW4	6206 2Z C3	29 x 40 x 4	-	-	-	-	6206 2Z C3	30 x 50 x 2	-	-	62	1	2	without
IE2-W21R 100 LX6, 8	6206 2Z C3	29 x 40 x 4	-	-	-	-	6206 2Z C3	30 x 50 x 2	-	-	62	1	2	without
IE2-WE1R 112 M2	6206 2Z C3	29 x 40 x 4	-	-	-	-	6206 2Z C3	30 x 50 x 2	-	-	62	1	2	without
IE2-WE1R 112 MX2	6206 2Z C3	29 x 40 x 4	-	-	-	-	6206 2Z C3	30 x 50 x 2	-	-	62	1	2	without
IE2-WE1R 112 MX6, M8	6206 2Z C3	29 x 40 x 4	-	-	-	-	6206 2Z C3	30 x 50 x 2	-	-	62	1	2	without
IE2-WE1R 112 MV2	6206 2Z C3	29 x 40 x 4	-	-	-	-	6206 2Z C3	30 x 50 x 2	-	-	62	1	2	without
IE2-W21R 112 MV6, 8	6206 2Z C3	29 x 40 x 4	-	-	-	-	6206 2Z C3	30 x 50 x 2	-	-	62	1	2	without
IE2-WE1R 112 MZ4	6206 2Z C3	29 x 40 x 4	-	-	-	-	6206 2Z C3	30 x 50 x 2	-	-	62	1	2	without
IE2-WE1R 112 MZ6	6206 2Z C3	29 x 40 x 4	-	-	-	-	6206 2Z C3	30 x 50 x 2	-	-	62	1	2	without
IE2-WE1R 132 SY2T	6208 2Z C3	39 x 50 x 4	-	-	80	-	6206 2Z C3	30 x 50 x 2	-	-	-	3	5	without
IE2-WE1R 132 S2T, SX2T	6208 2Z C3	39 x 50 x 4	-	-	80	-	6206 2Z C3	30 x 50 x 2	-	-	-	3	5	without
IE2-WE1R 132 SX6T	6208 2Z C3	39 x 50 x 4	-	-	80	-	6206 2Z C3	30 x 50 x 2	-	-	-	3	5	without
IE2-WE1R 112 M4	6207 2Z C3	34 x 45 x 4	-	-	-	-	6207 2Z C3	34 x 45 x 4	-	-	72	1	2	without
IE2-WE1R 132 S2, 6, 8, WE2R 132 SY4	6208 2Z C3	39 x 50 x 4	-	-	72	-	6207 2Z C3	34 x 45 x 4	-	-	-	3	5	without
IE2-WE2R 132 S4	6208 2Z C3	39 x 50 x 4	-	-	72	-	6207 2Z C3	34 x 45 x 4	-	-	-	3	5	without
IE2-WE2R 132 M6, 8	6208 2Z C3	39 x 50 x 4	-	-	72	-	6207 2Z C3	34 x 45 x 4	-	-	-	3	5	without
IE2-WE1R 132 SX2, S4, M4, 6, MX6	6308 ZZ C3	-	-	RB40	90	-	6308 ZZ C3	-	-	RB40	-	6	8	N-end
IE2-WE1R 132 M8	6308 ZZ C3	-	-	RB40	90	-	6308 ZZ C3	-	-	RB40	-	6	8	N-end
IE2-WE1R 160 M2, 4	6310 ZZ C3	-	-	RB50	110	-	6309 ZZ C3	-	-	RB45	-	6	8	N-end
IE2-WE(2)1R 160 MX2, L2, 4	6310 ZZ C3	-	-	RB50	110	-	6309 ZZ C3	-	-	RB45	-	6	8	N-end
IE2-WE1R 160 M6, L6, 8, MX8	6310 ZZ C3	-	-	RB50	110	-	6309 ZZ C3	-	-	RB45	-	6	8	N-end
IE2-WE1R 160 M8	6309 ZZ C3	-	-	RB45	100	-	6308 ZZ C3	-	-	RB40	-	6	8	N-end
IE2-WE1R 180 M2, M4, L4, 6	6310 C3	-	50A	-	110	-	6310 C3	-	50A	-	-	6	8	N-end
IE2-WE1R 180 L8	6310 ZZ C3	-	-	RB50	110	-	6310 ZZ C3	-	-	RB50	-	6	8	N-end
IE2-WE(2)1R 200 L2, 6, 8, LX2	6312 C3	-	60A	-	-	130	6310 C3	-	50A	-	-	6	8	N-end
IE2-WE1R 200 L4, LX6	6312 C3	-	60A	-	-	130	6312 C3	-	60A	-	-	6	8	N-end
IE2-WE1R 225 M2	6312 C3	-	60A	-	-	140	6312 C3	-	60A	-	-	6	8	N-end
IE2-WE1R 225 S4, 8	6313 C3	-	65A	-	-	140	6312 C3	-	60A	-	-	6	8	N-end
IE2-WE1R 225 M4, 6	6314 C3	-	70A	-	-	140	6313 C3	-	65A	-	-	6	8	N-end
IE2-WE1R 225 M8	6314 C3	-	70A	-	-	150	6313 C3	-	65A	-	-	6	8	N-end
IE2-WE1R 250 M2	6313 C3	-	65A	-	-	140	6313 C3	-	65A	-	-	6	8	N-end
IE2-WE1R 250 M4	6314 C3	-	70A	-	-	150	6313 C3	-	65A	-	-	6	8	N-end
IE2-WE1R 250 M6	6316 C3	-	70A	-	-	150	6314 C3	-	70A	-	-	6	8	N-end
IE2-WE1R 250 M8	6316 C3	-	80A	-	-	170	6314 C3	-	70A	-	-	6	8	N-end

¹⁾ For types for vertical mounting Q317 C3; figures 18, 21

(IE2-)WE1R 315 M6; MX; MY; L; LX with relubrication device as standard

Series IE2-W..R
Standard version

Type	Anti-friction bearing	D-end					N-end				Figure		Fixed bearing	
		Felt ring	V-ring	γ-ring	Wave spring	Disc spring	Felt ring	V-ring	γ-ring	Wave spring	DS	NS		
IE2-WE1R 280 S2, M2	6314 C3	-	70A	-	-	150	6314 C3	-	70A	-	-	6	8	N-end
IE2-WE1R 280 S4, M4	6316 C3	-	80A	-	-	170	6314 C3	-	70A	-	-	6	8	N-end
IE2-WE1R 280 S6, 8	6316 C3	-	80A	-	-	170	6314 C3	-	70A	-	-	6	8	N-end
IE2-WE1R 280 M6	6317 C3	-	85A	-	-	170	6316 C3	-	80A	-	-	6	8	N-end
IE2-WE1R 280 M8	6317 C3	-	85A	-	-	180	6316 C3	-	80A	-	-	6	8	N-end
IE2-WE1R 315 S2, M2	6316 C3	-	80A	-	-	170	6316 C3	-	80A	-	-	6	8	N-end
IE2-WE1R 315 S4,6; M4	6317 C3	-	85A	-	-	180	6316 C3	-	80A	-	-	6	8	N-end
IE2-WE1R 315 M6, MX4	6220 C3	-	-	RB100	-	180	6316 C3	-	80A	-	-	13	16	N-end
IE2-WE1R 315 MX2	6317 C3	-	-	RB85	-	180	6316 C3	-	80A	-	-	13	16	N-end
IE2-WE1R 315 MY2, L2, LX2	6317 C3	-	-	RB85	-	180	6317 C3 ¹⁾	-	85A	-	-	18	19	N-end
IE2-WE1R 315 L4,6; LX4,6, MX6	6320 C3	-	-	RB100	-	215	6317 C3 ¹⁾	-	85A	-	-	18	19	N-end
IE2-WE1R 315 S8	6317 C3	-	85A	-	-	180	6316 C3	-	80A	-	-	6	8	N-end
IE2-WE1R 315 M8	6220 C3	-	-	RB100	-	180	6316 C3	-	80A	-	-	13	16	N-end
IE2-WE1R 315 MX8	6320 C3	-	-	RB100	-	215	6317 C3 ¹⁾	-	85A	-	-	18	19	N-end
IE2-WE1R 315 MY8	6320 C3	-	-	RB100	-	215	6317 C3 ¹⁾	-	85A	-	-	18	19	N-end
IE2-WE1R 315 L8, LX8	6320 C3	-	-	RB100	-	215	6317 C3 ¹⁾	-	85A	-	-	18	19	N-end

Series IE2-W.1R
Reinforced Bearings

Type	Anti-friction bearing	D-end		Anti-friction bearing	N-end			Figure		Fixed bearing
		V-ring	γ-ring		Felt ring	V-ring	γ-ring	DS	NS	
IE2-WE1R 132 SX2, S4, M4, 6, 8; MX6	NU 308 E	-	RB40	6308 ZZ C3	-	-	RB40	7	9	N-end
IE2-WE1R 160 M2, 4, 6, 8	NU 310 E	-	RB50	6309 ZZ C3	-	-	RB45	7	9	N-end
IE2-WE1R 160 L2, 4, 8	NU 310 E	-	RB50	6309 ZZ C3	-	-	RB45	7	9	N-end
IE2-WE1R 160 MX2, 8	NU 310 E	-	RB50	6309 ZZ C3	-	-	RB45	7	9	N-end
IE2-WE1R 180 M2, M4, L4, L6	NU 310 E	50A	-	6310 C3	-	50A	-	7	9	N-end
IE2-WE1R 180 L8	NU 310 E	-	RB50	6310 ZZ C3	-	-	RB50	7	9	N-end
IE2-WE1R 200 L2, 6, 8; LX2	NU 312 E	60A	-	6310 C3	-	50A	-	7	9	N-end
IE2-WE1R 200 L4, LX6	NU 312 E	60A	-	6312 C3	-	60A	-	7	9	N-end
IE2-WE1R 225 M2	NU 312 E	60A	-	6312 C3	-	60A	-	7	9	N-end
IE2-WE1R 225 S4, 8	NU 313 E	65A	-	6312 C3	-	60A	-	7	9	N-end
IE2-WE1R 225 M4, 6, 8	NU 314 E	70A	-	6313 C3	-	65A	-	7	9	N-end
IE2-WE1R 250 M2	NU 313 E	65A	-	6313 C3	-	65A	-	7	9	N-end
IE2-WE1R 250 M4	NU 314 E	70A	-	6313 C3	-	65A	-	7	9	N-end
IE2-WE1R 250 M6	NU 316 E	80A	-	6314 C3	-	65A	-	7	9	N-end
IE2-WE1R 250 M8	NU 316 E	80A	-	6314 C3	-	70A	-	7	9	N-end
IE2-WE1R 280 S2, M2	NU 314 E	70A	-	6314 C3	-	70A	-	7	9	N-end
IE2-WE1R 280 S4, 6, 8; M4	NU 316 E	80A	-	6314 C3	-	70A	-	7	9	N-end
IE2-WE1R 280 M6, 8	NU 317 E	85A	-	6316 C3	-	80A	-	7	9	N-end
IE2-WE1R 315 S2,M2	NU 316 E	80A	-	6316 C3	-	80A	-	7	9	N-end
IE2-WE1R 315 S4,6, 8; M4	NU 317 E	85A	-	6316 C3	-	80A	-	7	9	N-end
IE2-WE1R 315 MX4, M6	NU 2220 E	-	RB100	6316 C3	-	80A	-	15	16	N-end
IE2-WE1R 315 MX2	NU 317 E	-	RB85	6316 C3	-	80A	-	15	16	N-end
IE2-WE1R 315 MY2, L2, LX2	NU 317 E	-	RB85	6317 C3 ¹⁾	-	85A	-	20	19	N-end
IE2-WE1R 315 L4,6; LX4,6; MX6, 8	NU 320 E	-	RB100	6317 C3 ¹⁾	-	85A	-	20	19	N-end
IE2-WE1R 315 M8	NU 2220 E	-	RB100	6316 C3	-	80A	-	15	16	N-end
IE2-WE1R 315 MY8, L8, LX8	NU 320 E	-	RB100	6317 C3 ¹⁾	-	85A	-	20	19	N-end

¹⁾ For types for vertical mounting Q317 C3; figures 18, 21
(IE2-)WE1R 315 M6; MX; MY; L; LX with relubrication device as standard

Series IE2-W.1R Relubrication device

Type	D-end						N-end			Figure				Fixed bearing
	Anti-friction bearing		V-ring	γ-ring	Wave spring ¹⁾	Disc spring ¹⁾	Anti-friction bearing	V-ring	DS	NS	DS	NS		
	Light-duty bearings	Reinforced bearings											Light-duty bearings	
IE2-WE1R 132 SX2	6308 C3	NU 308 E	-	RB40	90	-	6308 C3	40A	13	14	15	14	N-end	
IE2-WE1R 132 S4, M4,6; MX6	6308 C3	NU 308 E	-	RB40	90	-	6308 C3	40A	13	14	15	14	N-end	
IE2-WE1R 132 S6, 8					not possible at D-end for design reasons									
IE2-WE1R 132 M8	6308 C3	NU 308 E		RB40	90	-	6308 C3	40A	13	14	15	14	N-end	
IE2-WE1R 160 M2, 4, 6	6310 C3	NU 310 E	-	RB50	110	-	6309 C3	45A	13	14	15	14	N-end	
IE2-WE(2)1R 160 MX2, L2, 4, 6	6310 C3	NU 310 E	-	RB50	110	-	6309 C3	45A	13	14	15	14	N-end	
IE2-WE1R 160 M8					not possible at D-end for design reasons									
IE2-WE1R 160 MX8, L8	6310 C3	NU 310 E	-	RB50	110	-	6309 2Z C3	-	13	14	15	14	N-end	
IE2-WE1R 180 M2, 4; L4, 6	6310 C3	NU 310 E	-	RB50	110	-	6310 C3	50A	13	14	15	14	N-end	
IE2-WE1R 180 L8	6310 C3	NU 310 E	-	RB50	110	-	6310 2Z C3	-	13	14	15	14	N-end	
IE2-WE(2)1R 200 L2, 6, 8; LX2	6312 C3	NU 312 E	-	RB60	-	130	6310 C3	50A	13	14	15	14	N-end	
IE2-WE1R 200 L4, LX6	6312 C3	NU 312 E	-	RB60	-	130	6312 C3	60A	13	14	15	14	N-end	
IE2-WE1R 225 M2	6312 C3	NU 312 E	-	RB60	-	130	6312 C3	60A	13	14	15	14	N-end	
IE2-WE1R 225 S4, 8	6313 C3	NU 313 E	-	RB65	-	140	6312 C3	60A	13	14	15	14	N-end	
IE2-WE1R 225 M4, 6	6314 C3	NU 314 E	-	RB70	-	150	6313 C3	60A	13	14	15	14	N-end	
IE2-WE1R 225 M8	6314 C3	NU 314 E	-	RB70	-	150	6313 C3	65A	13	14	15	14	N-end	
IE2-WE1R 250 M2	6313 C3	NU 313 E	-	RB65	-	140	6313 C3	65A	13	14	15	14	N-end	
IE2-WE1R 250 M4	6314 C3	NU 314 E	-	RB70	-	150	6313 C3	65A	13	14	15	14	N-end	
IE2-WE1R 250 M6, 8	6316 C3	NU 316 E	-	RB80	-	170	6314 C3	70A	13	14	15	14	N-end	
IE2-WE1R 280 S2, M2	6314 C3	NU 314 E	-	RB70	-	150	6314 C3	70A	13	14	15	14	N-end	
IE2-WE1R 280 S4, 6, 8; M4	6316 C3	NU 316 E	-	RB80	-	170	6314 C3	70A	13	14	15	14	N-end	
IE2-WE1R 280 M6, 8	6317 C3	NU 317 E	-	RB85	-	180	6316 C3	80A	13	14	15	14	N-end	
IE2-WE1R 315 S2,M2	6316 C3	NU 316 E	-	RB80	-	170	6316 C3	80A	13	14	15	14	N-end	
IE2-WE1R 315 S4,6; M4	6317 C3	NU 317 E	-	RB85	-	180	6316 C3	80A	13	14	15	14	N-end	
IE2-WE1R 315 M6, 8							see basic version							
IE2-WE1R 315 MX2, 4, 6, 8							see basic version							
IE2-WE1R 315 MY2, 8							see basic version							
IE2-W21R 315 LX2, 4, 6, 8							see basic version							
IE2-WE1R 315 S8	6317 C3	NU 317 E	-	RB85	-	180	6316 C3	80A	13	14	15	14	N-end	
IE2-WE1R 315 L2, 4, 6, 8							see basic version							

¹⁾ Light-duty bearings only

Series IE2-WE2R
Standard version

Type	Anti-friction bearing	D-end				Anti-friction bearing	N-end		Figure		Fixed bearing
		V-ring	γ-ring	Wave spring	Disc spring		V-ring	γ-ring	DS	NS	
IE2-WE2R 132 S4	6208 ZZ C3		RB40	80	-	6207 ZZ C3		RB35	6	8	N-end
IE2-WE2R 160 M4	6309 ZZ C3		RB45	100	-	6308 ZZ C3		RB40	6	8	N-end
IE2-WE2R 160 L4	6310 ZZ C3	-	RB50	110	-	6309 ZZ C3	-	RB45	6	8	N-end
IE2-WE2R 180 M4	6310 C3	50A	-	110	-	6310 C3	50A	-	6	8	N-end
IE2-WE2R 200 LX2	6312 C3	60A	-	-	130	6310 C3	50A	-	6	8	N-end
IE2-WE2R 225 M4	6313 C3	65A	-	-	140	6312 C3	60A	-	6	8	N-end
IE2-WE2R 250 M4	6314 C3	70A	-	-	150	6313 C3	65A	-	6	8	N-end
IE2-WE2R 132 M6, 8	6208 ZZ C3		RB40	80	-	6207 ZZ C3		RB35	6	8	N-end
IE2-WE2R 160 M6, MX8	6309 ZZ C3		RB45	100	-	6308 ZZ C3		RB40	6	8	N-end
IE2-WE2R 180 L6	6310 ZZ C3	-	RB50	110	-	6309 ZZ C3	-	RB45	6	8	N-end
IE2-WE2R 180 L8	6310 ZZ C3	-	RB50	110	-	6309 ZZ C3	-	RB50	6	8	N-end
IE2-WE2R 200 LX6	6312 C3	60A	-	-	130	6310 C3	50A	-	6	8	N-end
IE2-WE2R 225 M6, 8; S8	6313 C3	65A	-	-	140	6312 C3	60A	-	6	8	N-end
IE2-WE2R 250 M6, 8	6314 C3	70A	-	-	150	6313 C3	65A	-	6	8	N-end

Series IE2-WE2R
Reinforced Bearings

Type	Anti-friction bearing	D-end				Anti-friction bearing	N-end		Figure		Fixed bearing
		V-ring	γ-ring	Wave spring	Disc spring		V-ring	γ-ring	DS	NS	
IE2-WE2R 132 S4; M6, 8	NU 208 E	-	RB40	80	-	6207 ZZ C3	-	RB35	7	9	N-end
IE2-WE2R 160 M4, 6; MX8	NU 309 E	-	RB45	100	-	6308 ZZ C3	-	RB40	7	9	N-end
IE2-WE2R 160 L4	NU 310 E	-	RB50	110	-	6309 ZZ C3	-	RB45	7	9	N-end
IE2-WE2R 180 M4	NU 310 E	50A	-	110	-	6310 C3	50A	-	7	9	N-end
IE2-WE2R 180 L6, 8	NU 310 E	-	RB50	110	-	6309 ZZ C3	-	RB45	7	9	N-end
IE2-WE2R 200 LX2, 6	NU 312 E	60A	-	-	130	6310 C3	50A	-	7	9	N-end
IE2-WE2R 225 M4, 6, 8; S8	NU 313 E	65A	-	-	140	6312 C3	60A	-	7	9	N-end
IE2-WE2R 250 M4, 6, 8	NU 314 E	70A	-	-	150	6313 C3	65A	-	7	9	N-end

Series IE2-WE2R
Relubrication device

Type	Anti-friction bearing		D-end				Anti-friction bearing	N-end		Figure				Fixed bearing
	Light-duty bearings	Reinforced bearings	V-ring	γ-ring	Wave spring ¹⁾	Disc spring ¹⁾		V-ring	γ-ring	DS	NS	DS	NS	
IE2-WE2R 132 S4; M6, 8														
IE2-WE2R 160 M4, 6; MX8														
IE2-WE2R 160 L4	6310 C3	NU 310 E	-	RB50	110	-	6309 C3	-	RB45	13	14	15	14	N-end
IE2-WE2R 180 M4	6310 C3	NU 310 E	-	RB50	110	-	6310 C3	50A	-	13	14	15	14	N-end
IE2-WE2R 180 L6, 8	6310 C3	NU 310 E	-	RB50	110	-	6309 C3	-	RB45	13	14	15	14	N-end
IE2-WE2R 200 LX2, 6	6312 C3	NU 312 E	-	RB60	-	130	6310 C3	50A	-	13	14	15	14	N-end
IE2-WE2R 225 M4, 6, 8	6313 C3	NU 313 E	-	RB65	-	140	6312 C3	60A	-	13	14	15	14	N-end
IE2-WE2R 225 S8	6313 C3	NU 312 E	-	RB60	-	140	6312 C3	60A	-	13	14	15	14	N-end
IE2-WE2R 250 M4, 6, 8	6314 C3	NU 314 E	-	RB70	-	150	6313 C3	65A	-	13	14	15	14	N-end

¹⁾ Light-duty bearings only

Series K21R Standard version

Type	D-end						N-end				Figure		Fixed bearing	
	Anti-friction bearing	V-ring	γ-ring	Felt ring	Wave spring	Disc spring	Anti-friction bearing	V-ring	γ-ring	Wave spring	Felt ring	DS		NS
K21R 56	6201 ZZ C3	-	-	11.5 x 19	-	-	6201 ZZ C3	-	-	32	12 x 22	1	2	without
K21R 63	6201 ZZ C3	-	-	11.5 x 19	-	-	6201 ZZ C3	-	-	32	12 x 22	1	2	without
K21R 71	6202 ZZ C3	-	-	14.5 x 21	-	-	6202 ZZ C3	-	-	35	15 x 24	1	2	without
(IE1-)K21R 80	6204 ZZ C3	-	-	19.5 x 26	-	-	6204 ZZ C3	-	-	47	20 x 32	1	2	without
(IE1-)K21R 90	6205 ZZ C3	-	-	24.5 x 35	-	-	6205 ZZ C3	-	-	52	25 x 40	1	2	without
(IE1-)K21R 100	6206 ZZ C3	-	-	29.2 x 40	-	-	6205 ZZ C3	-	-	52	25 x 40	1	2	without
(IE1-)K21R 100 LX	6206 ZZ C3	-	-	29.2 x 40	-	-	6206 ZZ C3	-	-	62	30 x 50	1	2	without
(IE1-)K21R 112 M	6206 ZZ C3	-	-	29.2 x 40	-	-	6206 ZZ C3	-	-	62	30 x 50	1	2	without
(IE1-)K21R 132 S2, 4T	6208 ZZ C3	-	-	39 x 60	-	-	6206 ZZ C3	-	-	62	30 x 50	1	2	without
(IE1-)K21R 132 S, SX2, M6, 8	6208 ZZ C3	-	RB40	-	80	-	6207 ZZ C3	-	RB35	-	-	6	8	N-end
(IE1-)K21R 132 M4, MX6	6308 ZZ C3	-	RB40	-	90	-	6308 ZZ C3	-	RB40	-	-	6	8	N-end
(IE1-)K21R 160 M, MX6	6309 ZZ C3	-	RB45	-	100	-	6308 ZZ C3	-	RB40	-	-	6	8	N-end
(IE1-)K21R 160 MX2, L	6310 ZZ C3	-	RB50	-	110	-	6309 ZZ C3	-	RB45	-	-	6	8	N-end
(IE1-)K21R 180 M4, L6, 8	6310 ZZ C3	-	RB50	-	110	-	6309 ZZ C3	-	RB45	-	-	6	8	N-end
(IE1-)K21R 180 M2, L4	6310 C3	50A	-	-	110	-	6310 C3	50A	-	-	-	6	8	N-end
(IE1-)K21R 200 L, LX6	6312 C3	60A	-	-	-	130	6310 C3	50A	-	-	-	6	8	N-end
(IE1-)K21R 200 LX2	6312 C3	60A	-	-	-	130	6312 C3	60A	-	-	-	6	8	N-end
(IE1-)K21R 225 M2	6312 C3	60A	-	-	-	130	6312 C3	60A	-	-	-	6	8	N-end
(IE1-)K21R 225 S4,8, M4, 6, 8	6313 C3	65A	-	-	-	140	6312 C3	60A	-	-	-	6	8	N-end
(IE1-)K21R 250 M2	6313 C3	65A	-	-	-	140	6313 C3	65A	-	-	-	6	8	N-end
(IE1-)K21R 250 M4, 6, 8	6314 C3	70A	-	-	-	150	6313 C3	65A	-	-	-	6	8	N-end
(IE1-)K21R 280 S2, M2	6314 C3	70A	-	-	-	150	6314 C3	70A	-	-	-	6	8	N-end
(IE1-)K21R 280 S4, 6, 8, M4, 6, 8	6316 C3	80A	-	-	-	170	6314 C3	70A	-	-	-	6	8	N-end
(IE1-)K21R 315 S2, M2	6316 C3	80A	-	-	-	170	6316 C3	80A	-	-	-	6	8	N-end
(IE1-)K21R 315 S4, 6, 8, M4, 6, 8	6317 C3	85A	-	-	-	180	6316 C3	80A	-	-	-	6	8	N-end
(IE1-)K21R 315 MX2	6317 C3	-	RB85	-	-	180	6316 C3	80A	-	-	-	13	16	N-end
(IE1-)K21R 315 MX4, 6, 8	6220 C3	-	RB100	-	-	180	6316 C3	80A	-	-	-	13	16	N-end
(IE1-)K21R 315 MY2	6317 C3	-	RB85	-	-	180	6317 C3 ¹⁾	85A	-	-	-	18	19	N-end
(IE1-)K21R 315 MY4, 6, 8	6320 C3	-	RB100	-	-	215	6317 C3 ¹⁾	85A	-	-	-	18	19	N-end
(IE1-)K21R 315 L2, LX2	6317 C3	-	RB85	-	-	180	6317 C3 ¹⁾	85A	-	-	-	18	19	N-end
(IE1-)K21R 315 L4, 6, 8, LX4, 6, 8	6320 C3	-	RB100	-	-	215	6317 C3 ¹⁾	85A	-	-	-	18	19	N-end
(IE1-)K22R 355 MY/M/MX/LY/L 2	6317 C3	-	RB85	-	-	180	6317 C3 ¹⁾	85A	-	-	-	18	19	N-end
(IE1-)K22R 355 MY/M/MX/LY/L 4, 6, 8	6324 C3	-	RB120	-	-	260	6317 C3 ¹⁾	85A	-	-	-	18	19	N-end

¹⁾ For types for vertical mounting Q317 C3; figures 18, 21
From size (IE1-)K21R 315 MX with relubrication device as standard

Series K20R Standard version

Type	Anti-friction bearing	D-end					Anti-friction bearing	N-end				Figure		Fixed bearing
		V-ring	γ-ring	Felt ring	Wave spring	Disc spring		V-ring	γ-ring	Wave spring	Felt ring	DS	NS	
K20R 56	6201 ZZ C3	-	-	11.5 x 19	-	-	6201 ZZ C3	-	-	32	12 x 22	1	2	without
K20R 63	6202 ZZ C3	-	-	14.5 x 21	-	-	6202 ZZ C3	-	-	35	15 x 24	1	2	without
(IE1)-K20R 71	6204 ZZ C3	-	-	19.5 x 26	-	-	6204 ZZ C3	-	-	47	20 x 32	1	2	without
(IE1)-K20R 80	6205 ZZ C3	-	-	24.2 x 35	-	-	6205 ZZ C3	-	-	52	25 x 40	1	2	without
(IE1)-K20R 90	6205 ZZ C3	-	-	24.5 x 35	-	-	6205 ZZ C3	-	-	52	25 x 40	1	2	without
(IE1)-K20R 100	6206 ZZ C3	-	-	29.2 x 40	-	-	6206 ZZ C3	-	-	62	30 x 50	1	2	without
(IE1)-K20R 112 M2, 4, 6, 8	6207 ZZ C3	-	RB35	-	72	-	6207 ZZ C3	-	RB35	-	-	6	8	N-end
(IE1)-K20R 112 MX6, 8	6207 ZZ C3	-	RB35	-	72	-	6207 ZZ C3	-	RB35	-	-	6	8	N-end
(IE1)-K20R 132 S, M	6308 ZZ C3	-	RB40	-	90	-	6308 ZZ C3	-	RB40	-	-	6	8	N-end
(IE1)-K20R 160 S, M	6310 ZZ C3	-	RB50	-	110	-	6309 ZZ C3	-	RB45	-	-	6	8	N-end
(IE1)-K20R 180 S2, M2	6310 C3	50A	-	-	110	-	6310 C3	50A	-	-	-	6	8	N-end
(IE1)-K20R 180 S4, 6, 8, M4, 6, 8	6312 C3	60A	-	-	-	130	6310 C3	50A	-	-	-	6	8	N-end
(IE1)-K20R 200 M2, L2	6312 C3	60A	-	-	-	130	6312 C3	60A	-	-	-	6	8	N-end
(IE1)-K20R 200 M4, 6, 8, L4, 6, 8	6313 C3	65A	-	-	-	140	6312 C3	60A	-	-	-	6	8	N-end
(IE1)-K20R 225 M2	6313 C3	65A	-	-	-	140	6313 C3	65A	-	-	-	6	8	N-end
(IE1)-K20R 225 M4, 6, 8	6314 C3	70A	-	-	-	150	6313 C3	65A	-	-	-	6	8	N-end
(IE1)-K20R 250 S2, M2	6314 C3	70A	-	-	-	150	6314 C3	70A	-	-	-	6	8	N-end
(IE1)-K20R 250 S4, 6, 8, M4, 6, 8	6316 C3	80A	-	-	-	170	6314 C3	70A	-	-	-	6	8	N-end
(IE1)-K20R 280 S2, M2	6316 C3	80A	-	-	-	170	6316 C3	80A	-	-	-	6	8	N-end
(IE1)-K20R 280 S4, 6, 8, M4, 6, 8	6317 C3	85A	-	-	-	180	6316 C3	80A	-	-	-	6	8	N-end
(IE1)-K20R 315 S2	6317 C3	-	RB85	-	-	180	6316 C3	80A	-	-	-	13	16	N-end
(IE1)-K20R 315 S4, 6, 8	6220 C3	-	RB100	-	-	180	6316 C3	80A	-	-	-	13	16	N-end
(IE1)-K20R 315 M2, L2, LX2	6317 C3	-	RB85	-	-	180	6317 C3 ¹⁾	85A	-	-	-	18	19	N-end
(IE1)-K20R 315 M4, 6, 8, L4, 6, 8, LX4, 6, 8	6320 C3	-	RB100	-	-	215	6317 C3 ¹⁾	85A	-	-	-	18	19	N-end

¹⁾ For types for vertical mounting Q317 C3; figures 18, 21
From size IE1-K20R 315 with relubrication device as standard

Series K21R Reinforced Bearings

Type	Anti-friction bearing	D-end		N-end		Figure		Fixed bearing
		V-ring	γ-ring	V-ring	DS	NS		
							Anti-friction bearing	
(IE1-)K21R 132 S, SX2, M6, 8 VL	NU 208 E	40A	-	6207 RS C3	-	4	10	N-end
(IE1-)K21R 132 M4, MX6 VL	NU 308 E	40A	-	6308 RS C3	-	4	10	N-end
(IE1-)K21R 160 M, MX8 VL	NU 309 E	45A	-	6308 RS C3	-	4	10	N-end
(IE1-)K21R 160 MX2, L VL	NU 310 E	50A	-	6309 RS C3	-	7	10	N-end
(IE1-)K21R 180 M4, L6, 8 VL	NU 310 E	50A	-	6309 RS C3	-	7	10	N-end
(IE1-)K21R 180 M2, L4 VL	NU 310 E	50A	-	6310 C3	50A	7	9	N-end
(IE1-)K21R 200 L, LX6 VL	NU 312 E	60A	-	6310 C3	50A	7	9	N-end
(IE1-)K21R 200 LX2 VL	NU 312 E	60A	-	6312 C3	60A	7	9	N-end
(IE1-)K21R 225 M2 VL	NU 312 E	-	RB60	6312 C3	60A	7	9	N-end
(IE1-)K21R 225 S4, 8, M4, 6, 8 VL	NU 313 E	-	RB65	6312 C3	60A	7	9	N-end
(IE1-)K21R 250 M2 VL	NU 313 E	-	RB65	6313 C3	65A	7	9	N-end
(IE1-)K21R 250 M4, 6, 8 VL	NU 314 E	-	RB70	6313 C3	65A	7	9	N-end
(IE1-)K21R 280 S2, M2 VL	NU 314 E	-	RB70	6314 C3	70A	7	9	N-end
(IE1-)K21R 280 S4, 6, 8, M4, 6, 8 VL	NU 316 E	-	RB80	6314 C3	70A	7	9	N-end
(IE1-)K21R 315 S2, M2 VL	NU 316 E	-	RB80	6316 C3	80A	7	9	N-end
(IE1-)K21R 315 S4, 6, 8, M4, 6, 8 VL	NU 317 E	-	RB85	6316 C3	80A	7	9	N-end
(IE1-)K21R 315 MX2 VL	NU 317 E	-	RB85	6316 C3	80A	15	16	N-end
(IE1-)K21R 315 MX4, 6, 8 VL	NU 2220 E	-	RB100	6316 C3	80A	15	16	N-end
(IE1-)K21R 315 MY2 VL	NU 317 E	-	RB85	6317 C3 ¹⁾	85A	20	19	N-end
(IE1-)K21R 315 MY4, 6, 8 VL	NU 320 E	-	RB100	6317 C3 ¹⁾	85A	20	19	N-end
(IE1-)K21R 315 L2, LX2 VL	NU 317 E	-	RB85	6317 C3 ¹⁾	85A	20	19	N-end
(IE1-)K21R 315 L4, 6, 8, LX4, 6, 8 VL	NU 320 E	-	RB100	6317 C3 ¹⁾	85A	20	19	N-end
(IE1-)K22R 355 MY/M/MX/LY/L 2	NU 317 E	-	RB85	6317 C3 ¹⁾	85A	20	19	N-end
(IE1-)K22R 355 MY/M/MX/LY/L 4, 6, 8 VL	NU 324 E	-	RB120	6317 C3 ¹⁾	85A	20	19	N-end

¹⁾ For types for vertical mounting Q317 C3; figures 20, 21
From size (IE1-)K21R 315 MX with relubrication device as standard

Series K20R Reinforced Bearings

Type	Anti-friction bearing	D-end		N-end		Figure		Fixed bearing
		V-ring	γ-ring	V-ring	DS	NS		
							Anti-friction bearing	
(IE1-)K20R 112 M2, 4, 6, 8 VL	NU 207 E	35A	-	6207 RS C3	-	4	10	N-end
(IE1-)K20R 112 MX6, 8 VL	NU 207 E	35A	-	6207 RS C3	-	4	10	N-end
(IE1-)K20R 132 S, M VL	NU 308 E	40A	-	6308 RS C3	-	4	10	N-end
(IE1-)K20R 160 S, M VL	NU 310 E	50A	-	6309 RS C3	-	7	10	N-end
(IE1-)K20R 180 S2, M2 VL	NU 310 E	50A	-	6310 C3	50A	7	9	N-end
(IE1-)K20R 180 S4, 6, 8, M4, 6, 8 VL	NU 312 E	60A	-	6310 C3	50A	7	9	N-end
(IE1-)K20R 200 M2, L2 VL	NU 312 E	-	RB60	6312 C3	60A	7	9	N-end
(IE1-)K20R 200 M4, 6, 8, L4, 6, 8 VL	NU 313 E	-	RB65	6312 C3	60A	7	9	N-end
(IE1-)K20R 225 M2 VL	NU 313 E	-	RB65	6313 C3	65A	7	9	N-end
(IE1-)K20R 225 M4, 6, 8 VL	NU 314 E	-	RB70	6313 C3	65A	7	9	N-end
(IE1-)K20R 250 S2, M2 VL	NU 314 E	-	RB70	6314 C3	70A	7	9	N-end
(IE1-)K20R 250 S4, 6, 8, M4, 6, 8 VL	NU 316 E	-	RB80	6314 C3	70A	7	9	N-end
(IE1-)K20R 280 S2, M2 VL	NU 316 E	-	RB80	6316 C3	80A	7	9	N-end
(IE1-)K20R 280 S4, 6, 8, M4, 6, 8 VL	NU 317 E	-	RB85	6316 C3	80A	7	9	N-end
(IE1-)K20R 315 S2 VL	NU 317 E	-	RB85	6316 C3	80A	15	16	N-end
(IE1-)K20R 315 S4, 6, 8 VL	NU 2220 E	-	RB100	6316 C3	80A	15	16	N-end
(IE1-)K20R 315 M2, L2, LX2 VL	NU 317 E	-	RB85	6317 C3 ¹⁾	85A	20	19	N-end
(IE1-)K20R 315 M4, 6, 8, L4, 6, 8, LX4, 6, 8 VL	NU 320 E	-	RB100	6317 C3 ¹⁾	85A	20	19	N-end

¹⁾ For types for vertical mounting Q317 C3; figures 20, 21
From size (IE1-)K20R 315 with relubrication device as standard

Series K21R Relubrication device

Type	D-end						N-end		Figure					Fixed bearing
	Anti-friction bearing		V-ring	γ-ring	Wave spring ¹⁾	Disc spring ¹⁾	Anti-friction bearing	V-ring	DS	NS	DS	NS		
	Light-duty Bearings	Reinforced Bearings							Light-duty Bearings	Light-duty Bearings	Reinforced Bearings	Reinforced Bearings		
(IE1-)K21R 132 S, SX2, M6, 8					not possible at D-end for design reasons									
(IE1-)K21R 132 M4, MX6	6308 C3	NU308 E		RB40	90		6308 C3	40A	13	14	15	14	N-end	
(IE1-)K21R 160 M, MX8					not possible at D-end for design reasons									
(IE1-)K21R 160 MX2, L	6310 C3	NU 310 E	-	RB50	110	-	6309 C3	45A	13	14	15	14	N-end	
(IE1-)K21R 180 M4, L6, 8	6310 C3	NU 310 E	-	RB50	110	-	6309 C3	45A	13	14	15	14	N-end	
(IE1-)K21R 180 M2, L4	6310 C3	NU 310 E	-	RB50	110	-	6310 C3	50A	13	14	15	14	N-end	
(IE1-)K21R 200 L, LX6	6312 C3	NU 312 E	-	RB60	-	130	6310 C3	50A	13	14	15	14	N-end	
(IE1-)K21R 200 LX2	6312 C3	NU 312 E	-	RB60	-	130	6312 C3	60A	13	14	15	14	N-end	
(IE1-)K21R 225 M2	6312 C3	NU 312 E	-	RB60	-	130	6312 C3	60A	13	14	15	14	N-end	
(IE1-)K21R 225 S4, 8, M4, 6, 8	6313 C3	NU 313 E	-	RB65	-	140	6312 C3	60A	13	14	15	14	N-end	
(IE1-)K21R 250 M2	6313 C3	NU 313 E	-	RB65	-	140	6313 C3	65A	13	14	15	14	N-end	
(IE1-)K21R 250 M4, 6, 8	6314 C3	NU 314 E	-	RB70	-	150	6313 C3	65A	13	14	15	14	N-end	
(IE1-)K21R 280 S2, M2	6314 C3	NU 314 E	-	RB70	-	150	6314 C3	70A	13	14	15	14	N-end	
(IE1-)K21R 280 S4, 6, 8, M4, 6, 8	6316 C3	NU 316 E	-	RB80	-	170	6314 C3	70A	13	14	15	14	N-end	
(IE1-)K21R 315 S2, M2	6316 C3	NU 316 E	-	RB80	-	170	6316 C3	80A	13	14	15	14	N-end	
(IE1-)K21R 315 S4, 6, 8, M4, 6, 8	6317 C3	NU 317 E	-	RB85	-	180	6316 C3	80A	13	14	15	14	N-end	
(IE1-)K21R 315 MX2													see basic version	
(IE1-)K21R 315 MX4, 6, 8													see basic version	
(IE1-)K21R 315 MY2													see basic version	
(IE1-)K21R 315 MY4, 6, 8													see basic version	
(IE1-)K21R 315 L2, LX2													see basic version	
(IE1-)K21R 315 L4, 6, 8, LX4, 6, 8													see basic version	
(IE1-)K22R 355 MY/M/MX/LY/L 2													see basic version	
(IE1-)K22R 355 MY/M/MX/LY/L 4, 6, 8													see basic version	

¹⁾ Light-duty bearings only

Series K20R Relubrication device

Type	D-end						N-end		Figure					Fixed bearing
	Anti-friction bearing		V-ring	γ-ring	Wave spring ¹⁾	Disc spring ¹⁾	Anti-friction bearing	V-ring	DS	NS	DS	NS		
	Light-duty Bearings	Reinforced Bearings							Light-duty Bearings	Light-duty Bearings	Reinforced Bearings	Reinforced Bearings		
(IE1-)K20R 132 S, M	6308 C3	NU 308 E	-	RB40	90	-	6308 C3	40A	13	14	15	14	N-end	
(IE1-)K20R 160 S, M	6310 C3	NU 310 E	-	RB50	110	-	6309 C3	45A	13	14	15	14	N-end	
(IE1-)K20R 180 S2, M2	6310 C3	NU 310 E	-	RB50	110	-	6310 C3	50A	13	14	15	14	N-end	
(IE1-)K20R 180 S4, 6, 8, M4, 6, 8	6312 C3	NU 312 E	-	RB60	-	130	6310 C3	50A	13	14	15	14	N-end	
(IE1-)K20R 200 M2, L2	6312 C3	NU 312 E	-	RB60	-	130	6312 C3	60A	13	14	15	14	N-end	
(IE1-)K20R 200 M4, 6, 8, L4, 6, 8	6313 C3	NU 313 E	-	RB65	-	140	6312 C3	60A	13	14	15	14	N-end	
(IE1-)K20R 225 M2	6313 C3	NU 313 E	-	RB65	-	140	6313 C3	65A	13	14	15	14	N-end	
(IE1-)K20R 225 M4, 6, 8	6314 C3	NU 314 E	-	RB70	-	150	6313 C3	65A	13	14	15	14	N-end	
(IE1-)K20R 250 S2, M2	6314 C3	NU 314 E	-	RB70	-	150	6314 C3	70A	13	14	15	14	N-end	
(IE1-)K20R 250 S4, 6, 8, M4, 6, 8	6316 C3	NU 316 E	-	RB80	-	170	6314 C3	70A	13	14	15	14	N-end	
(IE1-)K20R 280 S2, M2	6316 C3	NU 316 E	-	RB80	-	170	6316 C3	80A	13	14	15	14	N-end	
(IE1-)K20R 280 S4, 6, 8, M4, 6, 8	6317 C3	NU 317 E	-	RB85	-	180	6316 C3	80A	13	14	15	14	N-end	

¹⁾ Light-duty bearings only

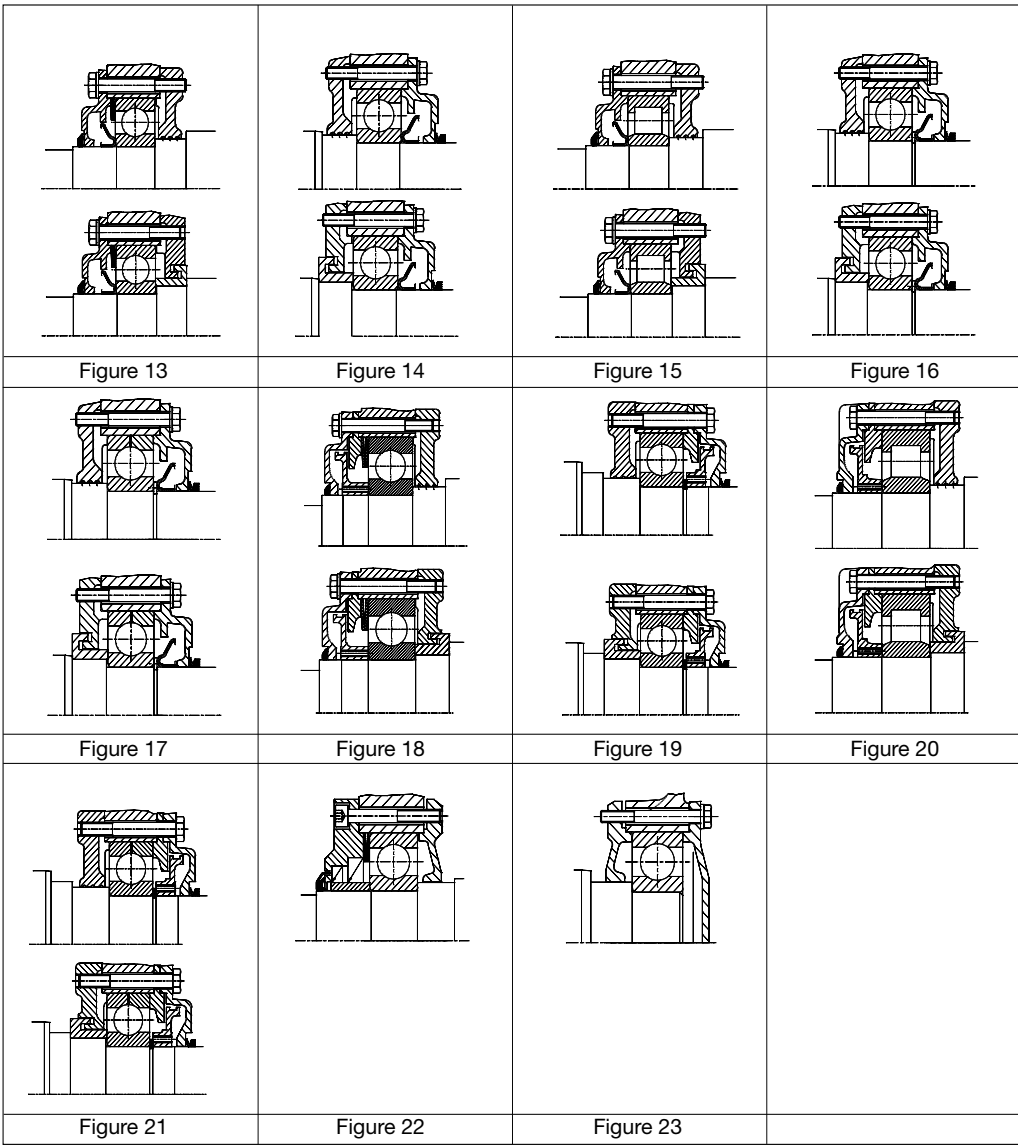
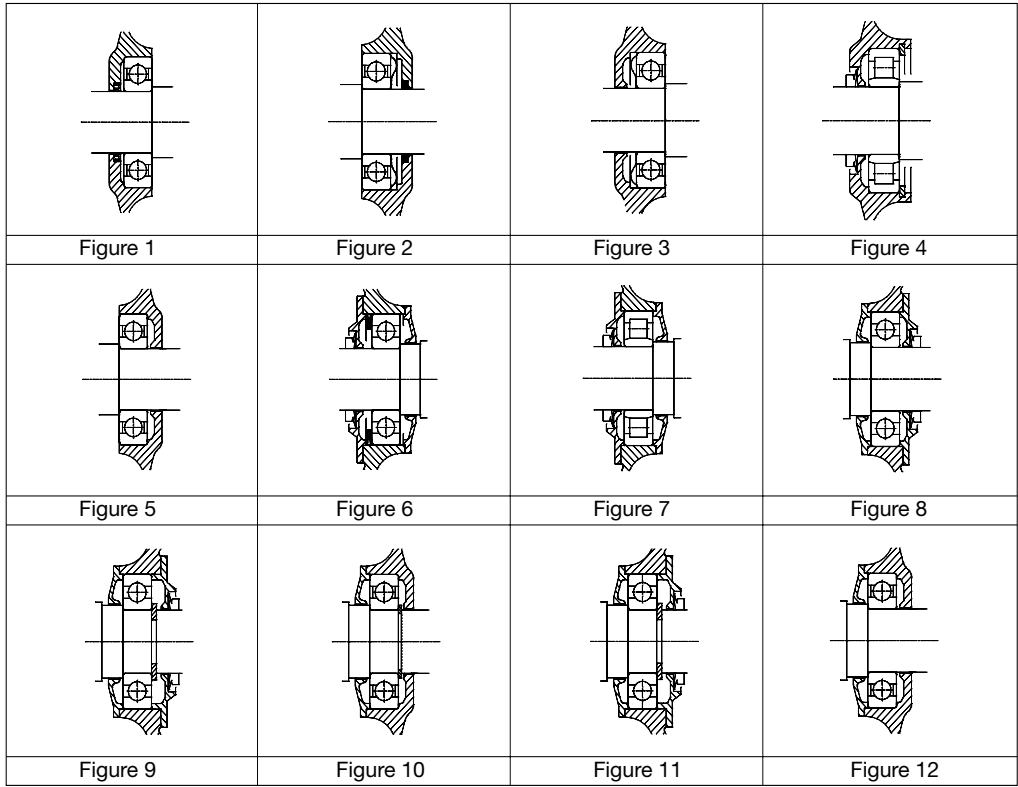

Standard version

Vertical shaft, permissible axial and radial forces (values in kN)

IE3-W4.R	Series/Size		2-pole			4-pole			6-pole			8-pole		
	IE2-WE.R	(IE1-)K21R	F _a	F _{r0.5}	F _{r1.0}	F _a	F _{r0.5}	F _{r1.0}	F _a	F _{r0.5}	F _{r1.0}	F _a	F _{r0.5}	F _{r1.0}
IE3-W41R 56/W42R 63	IE2-WE2R 56/WE2R 63	(IE1-)K21R 56/63	0.05	0.32		0.09	0.39		0.16	0.39	-	-		
IE3-W41R 63/W42R 71	IE2-WE1R 63/WE2R 71	(IE1-)K21R 71	0.07	0.34		0.12	0.43		0.19	0.43	0.25	0.43		
IE3-W41R 71/W42R 80	IE2-WE1R 71/WE2R 80	(IE1-)K21R 80	0.13	0.58		0.24	0.73		0.36	0.73	0.46	0.73		
IE3-W41R 80	IE2-WE1R 80	(IE1-)K20R 80	0.13	0.6		0.2	0.77		0.36	0.77	0.44	0.77		
IE3-W42R 90	IE2-WE2R 90	(IE1-)K21R 90	0.13	0.6		0.2	0.77		0.36	0.77	0.44	0.77		
IE3-W41R 90	IE2-WE1R 90	(IE1-)K21R 100	0.15	0.58		0.24	0.86		0.34	0.86	0.44	0.86		
IE3-W41R 100 /112/132..T	IE2-WE1R 100 /112 /132..T/ WE2R 100	(IE1-)K21R 100/112	0.17	0.77		0.31	0.98		0.42	0.98	0.52	0.98		
IE3-W41R 112 MW	IE2-WE1R 112 M	(IE1-)K20R 112 MX	-	-		0.85	1.4	1.2	-	-	-	-	-	-
IE3-W42R 132 S	IE2-WE2R 132 / W21R 132	(IE1-)K20R 112 M	0.75	1.15	1.0	0.9	1.4	1.2	1.1	1.6	1.4	1.3	1.75	1.5
IE3-W41R 132 S	IE2-WE1R 132 S	(IE1-)K21R 132 S	0.7	1.2	1.06	0.9	1.5	1.33	1.1	1.75	1.55	1.25	1.9	1.68
IE3-W41R 132 SX	IE2-WE1R 132 SX	(IE1-)K21R 132 SX	0.7	1.2	1.06	-	-	-	-	-	-	-	-	-
IE3-W41R 132 M	IE2-WE1R 132 M	(IE1-)K21R 132 M	-	-	-	1.4	2.1	1.9	1.05	1.7	1.5	1.25	1.9	1.68
IE3-W41R 132 MX	IE2-WE1R 132 MX	(IE1-)K21R 132 MX	-	-	-	-	-	-	1.65	2.4	2.1	-	-	-
IE3-W41R 160 M	IE2-WE1R 160 M	(IE1-)K21R 160 M	0.95	2.1	1.9	1.3	2.6	2.3	1.5	3.0	2.7	1.75	3.3	2.8
	IE2-WE2R 160 M		-	-	-	1.0	2.3	2.1	1.2	2.7	2.4	-	-	-
IE3-W41R 160 MX	IE2-WE1R 160 MX	(IE1-)K21R 160 MX	1.2	2.4	2.1	-	-	-	-	-	1.75	3.3	2.7	
IE3-W41R 160 L	IE2-WE1R 160 L	(IE1-)K21R 160 L	1.1	2.5	2.2	1.5	3.1	2.7	1.8	3.6	3.2	2.1	3.9	3.5
	IE2-WE2R 160 L		-	-	-	1.2	2.7	2.4	1.4	3.2	2.8	-	-	-
IE3-W41R 180 M	IE2-WE1R 180 M	(IE1-)K21R 180 M	1.4	2.5	2.2	1.5	3.1	2.7	-	-	-	-	-	-
	IE2-WE2R 180 M		-	-	-	1.5	2.8	2.5	-	-	-	-	-	-
IE3-W41R 180 L	IE2-WE1R 180 L	(IE1-)K21R 180 L	-	-	-	1.9	3.2	2.8	1.8	3.6	3.2	2.1	3.9	3.5
	IE2-WE2R 180 L		-	-	-	-	-	-	1.4	3.2	2.8	-	-	-
IE3-W41R 200 L	IE2-WE1R 200 L	(IE1-)K21R 200 L	1.3	3.4	3.0	1.8	4.2	3.7	2.0	4.9	4.3	2.4	5.4	4.8
IE3-W41R 200 LX	IE2-WE1R 200 LX	(IE1-)K21R 200 LX	1.9	3.4	3.0	-	-	-	2.0	4.8	4.2	-	-	-
	IE2-WE2R 200 LX		1.5	3.1	2.7	-	-	-	1.6	4.3	3.7	-	-	-
IE3-W41R 225 S	IE2-WE1R 225 S	(IE1-)K21R 225 S	-	-	-	2.3	4.6	4.1	-	-	-	3.2	6.0	5.3
IE3-W41R 225 M	IE2-WE1R 225 M	(IE1-)K21R 225 M	1.7	3.4	3.0	2.2	4.8	4.2	2.7	5.4	4.8	3.3	5.9	5.2
	IE2-WE2R 225 M		-	-	-	1.7	4.3	3.7	2.1	4.8	4.3	-	-	-
IE3-W41R 250 M	IE2-WE1R 250 M	(IE1-)K21R 250 M	1.8	3.8	3.4	2.4	5.3	4.7	3.0	6.1	5.4	3.3	6.7	5.9
	IE2-WE2R 250 M		-	-	-	1.9	4.7	4.2	2.4	5.4	4.8	-	-	-
IE3-W41R 280 S	IE2-WE1R 280 S	(IE1-)K21R 280 S	2.0	5.5	5.0	3.0	8.1	7.4	3.8	9.3	8.6	4.0	10.3	9.5
IE3-W41R 280 M	IE2-WE1R 280 M	(IE1-)K21R 280 M	2.0	5.6	5.1	2.3	8.2	7.6	3.0	9.5	8.9	3.0	10.6	9.9
IE3-W41R 315 S	IE2-WE1R 315 S	(IE1-)K21R 315 S	2.5	6.5	6.0	3.0	8.3	7.5	3.0	9.5	8.7	4.0	10.5	9.6
IE3-W41R 315 M	IE2-WE1R 315 M	(IE1-)K21R 315 M	2.5	6.6	6.1	3.0	8.4	7.8	3.0	9.7	9.1	4.0	10.8	10.2
IE3-W41R 315 MX	IE2-WE1R 315 MX	(IE1-)K21R 315 MX	2.0	7.0	6.5	1.5	11.4	7.3	2.3	12.9	12.1	3.0	14.3	13.5
IE3-W41R 315 MY	IE2-WE1R 315 MY	(IE1-)K21R 315 MY	1.5	7.0	6.6	1.5	11.5	10.9	1.5	13.5	13.0	2.0	15.1	14.8

Reinforced Bearings

Vertical shaft, permissible axial and radial forces (values in kN)

IE3-W4.R	Series/Size		2-pole			4-pole			6-pole			8-pole		
	IE2-WE.R	(IE1-)K21R	F _a	F _{r0.5}	F _{r1.0}	F _a	F _{r0.5}	F _{r1.0}	F _a	F _{r0.5}	F _{r1.0}	F _a	F _{r0.5}	F _{r1.0}
IE3-W41R 132 S	IE2-WE1R 132 S	(IE1-)K21R 132 S	0.7	2.4	1.12	0.9	3.0	2.66	2.2	3.5	3.1	1.25	3.8	3.36
IE3-W41R 132 SX	IE2-WE1R 132 SX	(IE1-)K21R 132 SX	0.7	2.4	1.12	-	-	-	-	-	-	-	-	-
IE3-W41R 132 M	IE2-WE1R 132 M	(IE1-)K21R 132 M	-	-	-	1.4	4.2	3.8	1.05	3.4	3.0	1.25	3.8	3.36
IE3-W41R 132 MX	IE2-WE1R 132 MX	(IE1-)K21R 132 MX	-	-	-	-	-	-	1.65	4.8	4.2	-	-	-
IE3-W41R 160 M	IE2-WE1R 160 M	(IE1-)K21R 160 M	0.95	4.2	3.8	1.3	5.2	4.6	3.0	6.0	5.4	1.75	6.6	5.6
	IE2-WE2R 160 M		-	-	-	1.0	4.1	3.7	2.4	4.8	4.3	-	-	-
IE3-W41R 160 MX	IE2-WE1R 160 MX	(IE1-)K21R 160 MX	1.2	4.8	4.2	-	-	-	-	-	-	1.75	6.6	5.4
IE3-W41R 160 L	IE2-WE1R 160 L	(IE1-)K21R 160 L	1.1	4.9	4.3	1.5	6.0	5.3	1.8	7.0	6.2	2.1	7.6	6.8
	IE2-WE2R 160 L		-	-	-	1.2	4.8	4.2	1.4	5.6	4.9	-	-	-
IE3-W41R 180 M	IE2-WE1R 180 M	(IE1-)K21R 180 M	1.4	4.9	4.3	1.5	6.0	5.3	-	-	-	-	-	-
	IE2-WE2R 180 M		-	-	-	1.5	4.9	4.4	-	-	-	-	-	-
IE3-W41R 180 L	IE2-WE1R 180 L	(IE1-)K21R 180 L	-	-	-	1.9	6.2	5.5	1.8	7.0	6.2	2.1	7.6	6.8
	IE2-WE2R 180 L		-	-	-	-	-	-	1.6	5.6	4.9	-	-	-
IE3-W41R 200 L	IE2-WE1R 200 L	(IE1-)K21R 200 L	1.3	6.6	5.9	1.8	8.2	7.2	2.0	9.6	8.4	2.4	10.5	9.4
IE3-W41R 200 LX	IE2-WE1R 200 LX	(IE1-)K21R 200 LX	1.9	6.6	5.7	-	-	-	2.0	9.1	8.0	-	-	-
	IE2-WE2R 200 LX		1.5	5.2	4.5	-	-	-	1.6	7.2	6.4	-	-	-
IE3-W41R 225 S	IE2-WE1R 225 S	(IE1-)K21R 225 S	-	-	-	2.3	8.7	7.8	-	-	-	3.2	11.4	10.1
IE3-W41R 225 M	IE2-WE1R 225 M	(IE1-)K21R 225 M	1.7	6.6	5.7	2.2	9.1	8.0	2.7	10.3	9.1	3.3	11.2	9.9
	IE2-WE2R 225 M		-	-	-	1.7	7.2	6.4	2.1	8.2	7.2	-	-	-
IE3-W41R 250 M	IE2-WE1R 250 M	(IE1-)K21R 250 M	1.8	7.0	6.3	2.4	9.8	8.7	3.0	12.3	10.0	3.3	12.4	10.0
	IE2-WE2R 250 M		-	-	-	1.9	7.8	6.9	2.4	9.8	8.0	-	-	-
IE3-W41R 280 S	IE2-WE1R 280 S	(IE1-)K21R 280 S	2.0	7.8	6.8	1.4	20.1	15.8	1.9	21.6	16.1	2.3	23.6	15.3
IE3-W41R 280 M	IE2-WE1R 280 M	(IE1-)K21R 280 M	1.1	7.8	6.8	1.3	20.1	15.8	1.8	21.0	13.6	2.3	20.8	13.5
IE3-W41R 315 S	IE2-WE1R 315 S	(IE1-)K21R 315 S	1.9	8.8	7.7	1.3	19.8	17.5	1.9	22.4	18.7	2.4	24.0	17.5
IE3-W41R 315 M	IE2-WE1R 315 M	(IE1-)K21R 315 M	1.7	8.8	7.7	1.2	20.0	17.7	1.5	22.6	17.7	2.1	23.8	17.4
IE3-W41R 315 MX	IE2-WE1R 315 MX	(IE1-)K21R 315 MX	0.9	19.0	16.8	0.8	27.0	23.9	0.8	28.6	18.5	1.2	28.6	18.5
IE3-W41R 315 MY	IE2-WE1R 315 MY	(IE1-)K21R 315 MY	0.5	19.5	17.3	0.5	19.5	17.3	1.5	24.0	16.6	2.0	24.0	16.6

For sizes 315 L, LX and 355 upon request

Series K20R

Basic version

Horizontal shaft, permissible axial and radial forces (values in kN)

Size	2-pole			4-pole			6-pole			8-pole		
	F _a	F _{r0,5}	F _{r1,0}	F _a	F _{r0,5}	F _{r1,0}	F _a	F _{r0,5}	F _{r1,0}	F _a	F _{r0,5}	F _{r1,0}
(IE1-)K20R 56	0.05	0.32		0.09	0.39		0.16	0.39		-	-	
(IE1-)K20R 63	0.07	0.34		0.12	0.43		0.19	0.43		0.25	0.43	
(IE1-)K20R 71	0.13	0.58		0.24	0.73		0.36	0.73		0.46	0.73	
(IE1-)K20R 80	0.13	0.60		0.20	0.77		0.36	0.77		0.44	0.77	
(IE1-)K20R 90	0.15	0.58		0.24	0.86		0.34	0.86		0.44	0.86	
(IE1-)K20R 100	0.17	0.77		0.31	0.98		0.42	0.98		0.52	0.98	
(IE1-)K20R 112 M	0.75	1.1	1.0	1.05	1.35	1.19	1.2	1.55	1.4	1.4	1.7	1.5
(IE1-)K20R 112 MX	-	-	-	-	-	-	1.2	1.55	1.4	1.4	1.7	1.5
(IE1-)K20R 132 S	-	-	-	0.8	1.95	1.7	1.0	2.35	2.1	1.1	2.6	2.3
(IE1-)K20R 132 M	0.7	1.6	1.4	0.8	1.95	1.7	1.0	2.35	2.1	1.1	2.6	2.3
(IE1-)K20R 160 S	1.7	2.3	2.0	1.9	3.0	2.7	2.3	3.4	3.0	2.5	3.8	3.7
(IE1-)K20R 160 M	1.5	2.3	2.0	1.9	3.0	2.7	2.3	3.4	3.0	2.5	3.8	3.7
(IE1-)K20R 180 S	1.7	2.3	2.0	2.4	4.1	3.6	2.8	4.6	4.1	3.0	5.1	4.5
(IE1-)K20R 180 M	1.7	2.3	2.0	2.4	4.1	3.6	2.8	4.6	4.1	3.0	5.1	4.5
(IE1-)K20R 200 M	2.4	3.2	2.8	3.0	4.4	3.9	3.5	5.0	4.4	4.3	5.6	5.0
(IE1-)K20R 200 L	2.4	3.2	2.8	3.0	4.4	3.9	-	-	-	-	-	-
(IE1-)K20R 225 M	1.9	2.5	2.2	3.5	5.1	4.5	3.8	5.8	5.1	4.5	6.4	5.7
(IE1-)K20R 250 S	3.5	5.05	4.6	4.5	7.5	6.8	5.0	8.7	8.0	6.0	9.6	8.9
(IE1-)K20R 250 M	4.0	5.1	4.6	4.5	7.5	6.9	5.0	8.7	8.05	6.0	9.7	9.0
(IE1-)K20R 280 S	4.5	5.9	5.4	6.0	7.3	6.7	7.0	8.5	7.6	7.5	9.5	8.7
(IE1-)K20R 280 M	4.5	5.9	5.4	6.0	7.3	6.8	7.0	8.3	7.8	7.5	9.4	8.8
(IE1-)K20R 315 S	4.5	6.0	5.6	5.0	10.0	9.4	6.0	11.3	10.6	6.0	12.8	12.0
(IE1-)K20R 315 M	6.0	9.6	9.0	6.0	9.6	9.0	7.0	11.1	10.7	7.5	12.5	12.3

Series K20R

Reinforced Bearings

Horizontal shaft, permissible axial and radial forces (values in kN)

Size	2-pole			4-pole			6-pole			8-pole		
	F _a	F _{r0,5}	F _{r1,0}	F _a	F _{r0,5}	F _{r1,0}	F _a	F _{r0,5}	F _{r1,0}	F _a	F _{r0,5}	F _{r1,0}
(IE1-)K20R 112 M	0.75	2.2	2.4	1.05	2.7	2.38	1.2	3.1	2.8	1.4	3.4	3.0
(IE1-)K20R 112 MX	-	-	-	-	-	-	1.2	3.1	2.8	1.4	3.4	3.0
(IE1-)K20R 132 S	-	-	-	0.8	3.9	3.4	1.0	4.7	4.2	1.1	5.2	4.6
(IE1-)K20R 132 M	0.7	3.2	2.8	0.8	3.9	3.4	1.0	4.7	4.2	1.1	5.2	4.6
(IE1-)K20R 160 S	1.7	2.3	2.6	1.9	3.0	2.7	2.3	3.4	3.0	2.5	3.8	3.7
(IE1-)K20R 160 M	1.5	2.3	2.6	1.9	3.0	2.7	2.3	3.4	3.0	2.5	3.8	3.7
(IE1-)K20R 180 S	1.7	4.5	5.1	2.4	8.0	7.0	2.8	9.0	8.0	3.0	9.9	8.8
(IE1-)K20R 180 M	1.7	4.5	5.1	2.4	8.0	7.0	2.8	9.0	8.0	3.0	9.9	4.5
(IE1-)K20R 200 M	2.4	6.1	6.8	3.0	8.4	7.4	3.5	9.5	8.4	4.3	10.6	9.5
(IE1-)K20R 200 L	2.4	6.1	6.8	3.0	8.4	7.4	-	-	-	-	-	-
(IE1-)K20R 225 M	1.9	4.6	5.2	3.5	9.4	8.3	3.8	10.7	9.4	4.5	11.8	10.5
(IE1-)K20R 250 S	2.9	7.0	8.0	3.1	19.5	15.4	3.5	21.8	16.3	3.8	23.8	15.6
(IE1-)K20R 250 M	2.6	6.5	7.4	3.1	19.4	15.3	3.5	22.0	14.2	4.3	22.8	14.9
(IE1-)K20R 280 S	3.5	7.9	7.2	3.7	18.8	16.6	4.5	21.3	16.6	5.0	23.5	17.3
(IE1-)K20R 280 M	2.9	7.7	8.8	3.8	19.0	16.8	4.6	21.5	15.8	5.2	23.7	17.4
(IE1-)K20R 315 S	3.4	18.3	16.2	3.6	26.0	22.4	4.1	28.5	19.7	4.5	31.5	20.3
(IE1-)K20R 315 M	3.6	18.3	16.2	4.4	25.5	16.5	4.7	27.5	17.7	5.6	27.5	19.0

For size 315 L upon request

Series K20R

Basic version

Vertical shaft, permissible axial and radial forces (values in kN)

Size	2-pole			4-pole			6-pole			8-pole		
	F _a	F _{r0,5}	F _{r1,0}	F _a	F _{r0,5}	F _{r1,0}	F _a	F _{r0,5}	F _{r1,0}	F _a	F _{r0,5}	F _{r1,0}
(IE1-)K20R 56	0.05	0.32		0.09	0.39		0.16	0.39		-	-	
(IE1-)K20R 63	0.07	0.34		0.12	0.43		0.19	0.43		0.25	0.43	
(IE1-)K20R 71	0.13	0.58		0.24	0.73		0.36	0.73		0.46	0.73	
(IE1-)K20R 80	0.13	0.60		0.20	0.77		0.36	0.77		0.44	0.77	
(IE1-)K20R 90	0.15	0.58		0.24	0.86		0.34	0.86		0.44	0.86	
(IE1-)K20R 100	0.17	0.77		0.31	0.98		0.42	0.98		0.52	0.98	
(IE1-)K20R 112 M	0.75	1.15	1.0	0.9	1.4	1.2	1.1	1.6	1.4	1.3	1.75	1.5
(IE1-)K20R 112 MX	-	-	-	-	-	-	1.05	1.6	1.4	1.25	1.75	1.5
(IE1-)K20R 132 S	-	-	-	0.7	2.0	1.8	0.8	2.3	2.0	0.9	2.6	2.3
(IE1-)K20R 132 M	0.5	1.65	1.45	0.65	2.15	1.9	0.75	2.45	2.2	0.85	2.7	2.4
(IE1-)K20R 160 S	1.1	2.4	2.1	1.6	3.05	2.7	1.8	3.5	3.1	2.2	3.9	3.5
(IE1-)K20R 160 M	1.2	2.4	2.1	1.6	3.05	2.7	1.8	3.6	3.2	2.1	4.0	3.5
(IE1-)K20R 180 S	1.4	2.5	2.1	1.8	4.1	3.6	2.1	4.8	4.2	2.5	5.2	4.6
(IE1-)K20R 180 M	1.3	2.6	2.3	1.8	4.3	3.8	2.0	5.0	4.4	2.4	5.4	4.8
(IE1-)K20R 200 M	1.8	3.4	3.0	2.4	4.7	4.2	2.75	5.4	4.8	3.2	5.9	5.2
(IE1-)K20R 200 L	1.7	3.4	3.0	2.2	4.8	4.2	-	-	-	-	-	-
(IE1-)K20R 225 M	1.5	2.8	2.5	2.5	5.4	4.8	3.0	6.2	5.5	3.5	6.8	6.0
(IE1-)K20R 250 S	2.0	5.5	5.0	3.0	8.1	7.4	3.8	9.3	8.6	4.0	10.3	9.5
(IE1-)K20R 250 M	2.0	5.6	5.1	2.3	8.2	7.6	3.0	9.5	8.9	3.0	10.6	9.9
(IE1-)K20R 280 S	2.5	6.5	6.0	3.0	8.3	7.5	3.0	9.5	8.7	4.0	10.5	9.6
(IE1-)K20R 280 M	2.5	6.6	6.1	3.0	8.4	7.8	3.0	9.7	9.1	4.0	10.8	10.2
(IE1-)K20R 315 S	2.0	7.0	6.5	1.5	11.4	7.3	2.3	12.9	12.1	3.0	14.3	13.5
(IE1-)K20R 315 M	1.5	7.0	6.6	1.5	11.5	10.9	1.5	13.5	13.0	2.0	15.1	14.8

2

Series K20R

Reinforced Bearings

Vertical shaft, permissible axial and radial forces (values in kN)

Size	2-pole			4-pole			6-pole			8-pole		
	F _a	F _{r0,5}	F _{r1,0}	F _a	F _{r0,5}	F _{r1,0}	F _a	F _{r0,5}	F _{r1,0}	F _a	F _{r0,5}	F _{r1,0}
(IE1-)K20R 112 M	0.75	2.3	2.0	0.9	2.8	2.4	1.1	3.2	2.8	1.3	3.5	3.0
(IE1-)K20R 112 MX	-	-	-	-	-	-	1.05	3.2	2.8	1.25	3.5	3.0
(IE1-)K20R 132 S	-	-	-	0.7	4.0	3.6	0.8	4.6	4.0	0.9	5.2	4.6
(IE1-)K20R 132 M	0.5	3.3	2.9	0.65	4.3	3.8	0.75	4.9	4.4	0.85	5.4	4.8
(IE1-)K20R 160 S	1.1	4.7	4.1	1.6	5.9	5.3	1.8	6.8	6.0	2.2	7.6	6.8
(IE1-)K20R 160 M	1.2	4.7	4.1	1.6	5.9	5.3	1.8	7.0	6.2	2.1	7.8	6.8
(IE1-)K20R 180 S	1.4	4.9	4.1	1.8	8.0	7.0	2.1	9.4	8.2	2.5	10.1	9.0
(IE1-)K20R 180 M	1.3	5.1	4.5	1.8	8.4	7.4	2.0	9.8	8.6	2.4	10.5	9.4
(IE1-)K20R 200 M	1.8	6.5	5.7	2.4	8.9	8.0	2.75	10.3	9.1	3.2	11.2	9.9
(IE1-)K20R 200 L	1.7	6.5	5.7	2.2	9.1	8.0	-	-	-	-	-	-
(IE1-)K20R 225 M	1.5	5.3	4.8	2.5	10.3	9.1	3.0	11.8	10.5	3.5	12.9	11.4
(IE1-)K20R 250 S	1.9	7.8	6.8	1.4	20.4	16.0	1.8	22.6	17.0	2.2	23.8	15.4
(IE1-)K20R 250 M	1.1	8.0	8.0	1.3	20.1	15.8	1.8	20.8	13.4	2.2	20.6	13.3
(IE1-)K20R 280 S	1.9	9.1	8.1	1.4	19.8	17.5	1.9	22.4	18.7	2.4	24.1	17.7
(IE1-)K20R 280 M	1.7	9.3	8.1	1.2	20.1	17.8	1.5	22.5	17.6	2.1	23.9	17.6
(IE1-)K20R 315 S	0.9	19.2	17.0	0.8	27.0	23.1	0.8	28.5	18.4	1.5	28.5	18.4
(IE1-)K20R 315 M	0.5	20.5	18.1	0.5	20.5	13.2	1.4	24.0	15.5	2.0	24	15.5

For size 315 L upon request

Series IE3-W41R Bearings with backstop

Type	Basic type			D-end				N-end				Fixed bearing	Backstop (Ringspann)
			Anti-friction bearing	V-ring	γ-ring	Wave spring	Disc spring	Anti-friction bearing	V-ring	γ-ring			
IE3-W41R 132 SX2	W40R	132	6308 ZZ C3	-	RB40	90	-	6308 ZZ C3	-	RB40	N-end	FXM66DX	
IE3-W41R 132 S4	W40R	132	6308 ZZ C3	-	RB40	90	-	6308 ZZ C3	-	RB40	N-end	FXM66DX	
IE3-W41R 132 M4	W40R	132	6308 ZZ C3	-	RB40	90	-	6308 ZZ C3	-	RB40	N-end	FXM66DX	
IE3-W41R 160 M2	W40R	160	6310 ZZ C3	-	RB50	110	-	6309 ZZ C3	-	RB45	N-end	FXM66DX	
IE3-W41R 160 MX2	W40R	160	6310 ZZ C3	-	RB50	110	-	6309 ZZ C3	-	RB45	N-end	FXM66DX	
IE3-W41R 160 L2	W40R	160	6310 ZZ C3	-	RB50	110	-	6309 ZZ C3	-	RB45	N-end	FXM66DX	
IE3-W41R 160 M4	W40R	160	6310 ZZ C3	-	RB50	110	-	6309 ZZ C3	-	RB45	N-end	FXM66DX	
IE3-W41R 160 L4C	W40R	160	6310 ZZ C3	-	RB50	110	-	6309 ZZ C3	-	RB45	N-end	FXM66DX	
IE3-W41R 180 M2C	W40R	180	6310 C3	50A	-	110	-	6310 C3	50A	-	N-end	FXM86DX	
IE3-W41R 200 L2	W40R	200	6312 C3	60A	-	-	130	6312 C3	60A	-	N-end	FXM85SX	
IE3-W41R 200 LX2C	W40R	200	6312 C3	60A	-	-	130	6312 C3	60A	-	N-end	FXM85SX	
IE3-W41R 225 M2	W40R	225	6313 C3	65A	-	-	140	6313 C3	65A	-	N-end	FXM86DX	
IE3-W41R 250 M2	W40R	250	6314 C3	70A	-	-	150	6314 C3	70A	-	N-end	FXM100SX	
IE3-W41R 180 M4	W40R	180	6310 C3	50A	-	110	-	6310 C3	50A	-	N-end	FXM86DX	
IE3-W41R 180 L4	W40R	180	6310 C3	50A	-	110	-	6310 C3	50A	-	N-end	FXM86DX	
IE3-W41R 200 L4C	W40R	200	6312 C3	60A	-	-	130	6312 C3	60A	-	N-end	FXM85SX	
IE3-W41R 225 S4C	W40R	200	6313 C3	65A	-	-	140	6312 C3	60A	-	N-end	FXM85SX	
IE3-W41R 225 M4	W40R	225	6314 C3	70A	-	-	150	6313 C3	65A	-	N-end	FXM86DX	
IE3-W41R 250 M4	W40R	250	6316 C3	80A	-	-	170	6314 C3	70A	-	N-end	FXM100SX	
IE3-W41R 132 S6	W40R	112	6208 ZZ C3	-	RB40	80	-	6207 ZZ C3	-	RB35	N-end	FXM51DX	
IE3-W41R 132 M6	W40R	132	6308 ZZ C3	-	RB40	90	-	6308 ZZ C3	-	RB40	N-end	FXM66DX	
IE3-W41R 132 MX6	W40R	132	6308 ZZ C3	-	RB40	90	-	6308 ZZ C3	-	RB40	N-end	FXM66DX	
IE3-W41R 160 M6	W40R	160	6310 ZZ C3	-	RB50	110	-	6309 ZZ C3	-	RB45	N-end	FXM66DX	
IE3-W41R 160 L6C	W40R	160	6310 ZZ C3	-	RB50	110	-	6309 ZZ C3	-	RB45	N-end	FXM66DX	
IE3-W41R 180 L6C	W40R	180	6310 C3	50A	-	110	-	6310 C3	50A	-	N-end	FXM86DX	
IE3-W41R 200 L6	W40R	200	6312 C3	60A	-	-	130	6312 C3	60A	-	N-end	FXM85SX	
IE3-W41R 200 LX6C	W40R	200	6312 C3	60A	-	-	130	6312 C3	60A	-	N-end	FXM85SX	
IE3-W41R 225 M6	W40R	225	6314 C3	70A	-	-	150	6313 C3	65A	-	N-end	FXM86DX	
IE3-W41R 250 M6	W40R	250	6316 C3	80A	-	-	170	6314 C3	70A	-	N-end	FXM100SX	
IE3-W41R 280 S2	W40R	250	6314 C3	70A	-	-	150	6314 C3	70A	-	N-end	FXM100SX	
IE3-W41R 280 M2	W40R	250	6314 C3	70A	-	-	150	6314 C3	70A	-	N-end	FXM100SX	
IE3-W41R 280 S4	W40R	250	6316 C3	80A	-	-	170	6314 C3	70A	-	N-end	FXM100SX	
IE3-W41R 280 M4	W40R	280	6317 C3	85A	-	-	180	6316 C3	80A	-	N-end	FXM120SX	
IE3-W41R 280 S6, M6	W40R	280	6317 C3	85A	-	-	180	6316 C3	80A	-	N-end	FXM120SX	
IE3-W41R 315 S2, M2	W40R	280	6316 C3	80A	-	-	170	6316 C3	80A	-	N-end	FXM120SX	
IE3-W41R 315 MX2	W40R	315	6317 C3	85A	-	-	180	6317 C3 ¹⁾	85A	-	N-end	FXM120SX	
IE3-W41R 315 MY2, L2, LX2	W40R	315	6317 C3	85A	-	-	180	6317 C3 ¹⁾	85A	-	N-end	FXM120SX	
IE3-W41R 315 S4, M4	W40R	280	6317 C3	85A	-	-	180	6316 C3	80A	-	N-end	FXM120SX	
IE3-W41R 315 MX4	W40R	315	6320 C3	-	RB100	-	215	6317 C3 ¹⁾	85A	-	N-end	FXM120SX	
IE3-W41R 315 MY4	W40R	315	6320 C3	-	RB100	-	215	6317 C3 ¹⁾	85A	-	N-end	FXM120SX	
IE3-W41R 315 L4, LX4	W40R	315	6320 C3	-	RB100	-	215	6317 C3 ¹⁾	85A	-	N-end	FXM120SX	
IE3-W41R 315 S6	W40R	315	6320 C3	-	RB100	-	215	6317 C3 ¹⁾	85A	-	N-end	FXM120SX	
IE3-W41R 315 M6, MX6, MY6	W40R	315	6320 C3	-	RB100	-	215	6317 C3 ¹⁾	85A	-	N-end	FXM120SX	
IE3-W41R 355 M2	W40R	355	6317 C3	-	RB85A	-	180	6317 C3 ¹⁾	85A	-	N-end	FXM120SX	
IE3-W41R 355 M4, 6	W40R	355	6324 C3	-	RB120	-	260	6317 C3 ¹⁾	85A	-	N-end	FXM120SX	

¹⁾ For types for vertical mounting Q317 C3; figures 18, 21
IE3-W41R from 2-pole 315 MX, 4-pole 315 MX, 6-pole 315 S with relubrication device as standard

Type	Basic type	D-end				Anti-friction bearing		N-end		Fixed bearing	Backstop (Ringspann)	
		Anti-friction bearing	V-ring	γ-ring	Wave spring	Disc spring	V-ring	γ-ring				
IE3-W41R 132 S8	W40R	132	6308 ZZ C3	-	RB40	90	-	6308 ZZ C3	-	RB40	N-end	FXM66DX
IE3-W41R 132 M8	W40R	132	6308 ZZ C3	-	RB40	90	-	6308 ZZ C3	-	RB40	N-end	FXM66DX
IE3-W41R 160 M8	W40R	160	6310 ZZ C3	-	RB50	110	-	6309 ZZ C3	-	RB45	N-end	FXM66DX
IE3-W41R 160 MX8	W40R	160	6310 ZZ C3	-	RB50	110	-	6309 ZZ C3	-	RB45	N-end	FXM66DX
IE3-W41R 160 L8	W40R	160	6310 ZZ C3	-	RB50	110	-	6309 ZZ C3	-	RB45	N-end	FXM66DX
IE3-W41R 180 L8	W40R	180	6310 C3	50A	-	110	-	6310 C3	50A	-	N-end	FXM86DX
IE3-W41R 200 L8	W40R	180	6310 C3	50A	-	110	-	6310 C3	50A	-	N-end	FXM86DX
IE3-W41R 225 S8	W40R	200	6312 C3	60A	-	-	130	6312 C3	60A	-	N-end	FXM85SX
IE3-W41R 225 M8	W40R	225	6314 C3	70A	-	-	150	6313 C3	65A	-	N-end	FXM86SX
IE3-W41R 250 M8	W40R	225	6314 C3	70A	-	-	150	6313 C3	65A	-	N-end	FXM86SX
IE3-W41R 280 S8	W40R	250	6316 C3	80A	-	-	170	6314 C3	70A	-	N-end	FXM100SX
IE3-W41R 280 M8	W40R	280	6317 C3	85A	-	-	180	6316 C3	80A	-	N-end	FXM120SX
IE3-W41R 315 S8	W40R	280	6317 C3	85A	-	-	180	6316 C3	80A	-	N-end	FXM120SX
IE3-W41R 315 M8, MX8, MY8, L8	W40R	315	6320 C3	-	RB100	-	215	6317 C3 ¹⁾	85A	-	N-end	FXM120SX
IE3-W41R 355 M8	W40R	355	6324 C3	-	RB120	-	260	6317 C3 ¹⁾	85A	-	N-end	FXM120SX

¹⁾ For types for vertical mounting Q317 C3; figures 18, 21
IE3-W41R ab 315 M with relubrication device as standard

Series IE2-W..R Bearings with backstop

Type	Basic type	Anti-friction bearing	D-end					N-end				Figure		Fixed bearing	Backstop (Ringspann)	
			Felt ring	V-ring	γ-ring	Wave spring	Disc spring	Felt ring	V-ring	γ-ring	Wave spring	DS	NS			
IE2-WE1R 132 S2	112	6208 ZZ C3	-	-	RB40	80	-	6207 ZZ C3	-	-	RB35	-	6	8	N-end	FXM51DX
IE2-WE1R 132 SX2	132	6308 ZZ C3	-	-	RB40	90	-	6308 ZZ C3	-	-	RB40	-	6	8	N-end	FXM66DX
IE2-WE1R 132 S4, M4, M6, MX6	132	6308 ZZ C3	-	-	RB40	90	-	6308 ZZ C3	-	-	RB40	-	6	8	N-end	FXM66DX
IE2-WE1R 132 S6	112	6208 ZZ C3	-	-	RB40	80	-	6207 ZZ C3	-	-	RB35	-	6	8	N-end	FXM51DX
IE2-WE1R 160 M2, M4	160	6310 ZZ C3	-	-	RB50	110	-	6309 ZZ C3	-	-	RB45	-	6	8	N-end	FXM66DX
IE2-WE(2)1R 160 MX2, L2, L4	160	6310 ZZ C3	-	-	RB50	110	-	6309 ZZ C3	-	-	RB45	-	6	8	N-end	FXM66DX
IE2-WE1R 160 M6	160	6310 ZZ C3	-	-	RB50	110	-	6309 ZZ C3	-	-	RB45	-	6	8	N-end	FXM66DX
IE2-WE1R 160 L6	160	6310 ZZ C3	-	-	RB50	110	-	6309 ZZ C3	-	-	RB45	-	6	8	N-end	FXM66DX
IE2-WE1R 180 M2, M4, L4, L6	180	6310 C3	-	50A	-	110	-	6310 C3	-	50A	-	-	6	8	N-end	FXM86DX
IE2-WE(2)1R 200 L2, LX2	180	6312 C3	-	60A	-	-	130	6310 C3	-	50A	-	-	6	8	N-end	FXM86DX
IE2-WE1R 200 L4, LX6	200	6312 C3	-	60A	-	-	130	6312 C3	-	60A	-	-	6	8	N-end	FXM85SX
IE2-W21R 200 L6	180	6312 C3	-	60A	-	-	130	6310 C3	-	50A	-	-	6	8	N-end	FXM86DX
IE2-WE1R 225 M2	200	6312 C3	-	60A	-	-	140	6312 C3	-	60A	-	-	6	8	N-end	FXM85SX
IE2-WE1R 225 S4	200	6313 C3	-	65A	-	-	140	6312 C3	-	60A	-	-	6	8	N-end	FXM85SX
IE2-WE1R 225 M4, M6	225	6314 C3	-	70A	-	-	140	6313 C3	-	65A	-	-	6	8	N-end	FXM86DX
IE2-WE1R 250 M2	225	6313 C3	-	65A	-	-	140	6313 C3	-	65A	-	-	6	8	N-end	FXM86DX
IE2-WE1R 250 M4	225	6314 C3	-	70A	-	-	150	6313 C3	-	65A	-	-	6	8	N-end	FXM86DX
IE2-W21R 250 M6	250	6316 C3	-	70A	-	-	150	6314 C3	-	70A	-	-	6	8	N-end	FXM100SX
IE2-WE1R 280 S2, M2	250	6314 C3	-	70A	-	-	150	6314 C3	-	70A	-	-	6	8	N-end	FXM100SX
IE2-WE1R 280 S4, M4	250	6316 C3	-	80A	-	-	170	6314 C3	-	70A	-	-	6	8	N-end	FXM100SX
IE2-WE1R 280 S6	250	6316 C3	-	80A	-	-	170	6314 C3	-	70A	-	-	6	8	N-end	FXM100SX
IE2-WE1R 280 M6	280	6317 C3	-	85A	-	-	170	6316 C3	-	80A	-	-	6	8	N-end	FXM120SX
IE2-WE1R 315 S2, M2	280	6316 C3	-	80A	-	-	170	6316 C3	-	80A	-	-	6	8	N-end	FXM120SX
IE2-WE1R 315 S4,6, M4	280	6317 C3	-	85A	-	-	180	6316 C3	-	80A	-	-	6	8	N-end	FXM120SX
IE2-WE1R 315 M6	280	6220 C3	-	-	RB100	-	180	6316 C3	-	80A	-	-	13	16	N-end	FXM120SX
IE2-WE1R 315 MX2	280	6317 C3	-	-	RB85	-	180	6316 C3	-	80A	-	-	13	16	N-end	FXM120SX
IE2-WE1R 315 MX4	280	6220 C3	-	-	RB100	-	180	6316 C3	-	80A	-	-	13	16	N-end	FXM120SX
IE2-WE1R 315 MX6	315	6320 C3	-	-	RB100	-	215	6317 C3 ¹⁾	-	85A	-	-	18	19	N-end	FXM120SX
IE2-WE1R 315 MY2	315	6317 C3	-	-	RB85	-	180	6317 C3 ¹⁾	-	85A	-	-	18	19	N-end	FXM120SX
IE2-WE1R 315 L2, LX2	315	6317 C3	-	-	RB85	-	180	6317 C3 ¹⁾	-	85A	-	-	18	19	N-end	FXM120SX
IE2-WE1R 132 S8	112	6208 ZZ C3	-	-	RB40	80	-	6207 ZZ C3	-	-	RB35	-	6	8	N-end	FXM51DX
IE2-WE1R 132 M8	132	6308 ZZ C3	-	-	RB40	90	-	6308 ZZ C3	-	-	RB40	-	6	8	N-end	FXM66DX
IE2-WE1R 160 M8	132	6309 ZZ C3	-	-	RB45	100	-	6308 ZZ C3	-	-	RB40	-	6	8	N-end	FXM66DX
IE2-WE1R 160 MX8, L8	160	6310 ZZ C3	-	-	RB50	110	-	6309 ZZ C3	-	-	RB45	-	6	8	N-end	FXM66DX
IE2-WE1R 180 L8	160	6310 ZZ C3	-	-	RB50	110	-	6310 ZZ C3	-	-	RB50	-	6	8	N-end	FXM66DX
IE2-WE1R 200 L8	180	6312 C3	-	60A	-	-	130	6310 C3	-	50A	-	-	6	8	N-end	FXM86DX
IE2-WE1R 225 S8	200	6313 C3	-	65A	-	-	140	6312 C3	-	60A	-	-	6	8	N-end	FXM85SX
IE2-WE1R 225 M8	225	6314 C3	-	70A	-	-	150	6313 C3	-	65A	-	-	6	8	N-end	FXM86DX
IE2-WE1R 250 M8	250	6316 C3	-	80A	-	-	170	6314 C3	-	70A	-	-	6	8	N-end	FXM100SX
IE2-WE1R 280 S8	250	6316 C3	-	80A	-	-	170	6314 C3	-	70A	-	-	6	8	N-end	FXM100SX
IE2-WE1R 280 M8	280	6317 C3	-	85A	-	-	180	6316 C3	-	80A	-	-	6	8	N-end	FXM120SX
IE2-WE1R 315 S8	280	6317 C3	-	85A	-	-	180	6316 C3	-	80A	-	-	6	8	N-end	FXM120SX
IE2-WE1R 315 M8	280	6220 C3	-	-	RB100	-	180	6316 C3	-	80A	-	-	13	16	N-end	FXM120SX
IE2-WE1R 315 MX8	315	6320 C3	-	-	RB100	-	215	6317 C3 ¹⁾	-	85A	-	-	18	19	N-end	FXM120SX
IE2-WE1R 315 MY8	315	6320 C3	-	-	RB100	-	215	6317 C3 ¹⁾	-	85A	-	-	18	19	N-end	FXM120SX
IE2-WE1R 315 L8, LX8	315	6320 C3	-	-	RB100	-	215	6317 C3 ¹⁾	-	85A	-	-	18	19	N-end	FXM120SX

¹⁾ For types for vertical mounting Q317 C3; figures 18, 21
W21R 315 M; MX; MY; L; LX with relubrication device as standard

Series IE2-WE2R Bearings with backstop

Type	Basic type	D-end				N-end		Fixed bearing	Backstop (Ringspann)		
		Anti-friction bearing	V-ring	γ-ring	Wave spring	Disc spring	Anti-friction bearing			V-ring	γ-ring
IE2-WE2R 132 S4	112	6208 ZZ C3		RB40	80	-	6207 ZZ C3		RB35	N-end	FXM51DX
IE2-WE2R 160 M4	132	6309 ZZ C3		RB45	100	-	6308 ZZ C3		RB40	N-end	FXM66DX
IE2-WE2R 160 L4	160	6310 ZZ C3	-	RB50	110	-	6309 ZZ C3	-	RB45	N-end	FXM66DX
IE2-WE2R 180 M4	180	6310 C3	50A	-	110	-	6310 C3	50A	-	N-end	FXM86DX
IE2-WE2R 200 LX2	180	6312 C3	60A	-	-	130	6310 C3	50A	-	N-end	FXM86DX
IE2-WE2R 225 M4	200	6313 C3	65A	-	-	140	6312 C3	60A	-	N-end	FXM85SX
IE2-WE2R 250 M4	225	6314 C3	70A	-	-	150	6313 C3	65A	-	N-end	FXM86DX
IE2-WE2R 132 M6	112	6208 ZZ C3		RB40	80	-	6207 ZZ C3		RB35	N-end	FXM51DX
IE2-WE2R 160 M6	132	6309 ZZ C3		RB45	100	-	6308 ZZ C3		RB40	N-end	FXM66DX
IE2-WE2R 180 L6	160	6310 ZZ C3	-	RB50	110	-	6309 ZZ C3	-	RB45	N-end	FXM66DX
IE2-WE2R 200 LX6	180	6312 C3	60A	-	-	130	6310 C3	50A	-	N-end	FXM86DX
IE2-WE2R 225 M6	200	6313 C3	65A	-	-	140	6312 C3	60A	-	N-end	FXM85SX
IE2-WE2R 250 M6	225	6314 C3	70A	-	-	150	6313 C3	65A	-	N-end	FXM86DX
IE2-WE2R 132 M8	112	6208 ZZ C3		RB40	80	-	6207 ZZ C3		RB35	N-end	FXM51DX
IE2-WE2R 160 MX8	132	6309 ZZ C3		RB45	100	-	6308 ZZ C3		RB40	N-end	FXM66DX
IE2-WE2R 180 L8	160	6310 ZZ C3	-	RB50	110	-	6309 ZZ C3	-	RB50	N-end	FXM66DX
IE2-WE2R 225 S8	200	6313 C3	65A	-	-	140	6312 C3	60A	-	N-end	FXM85SX
IE2-WE2R 225 M8	200	6313 C3	65A	-	-	140	6312 C3	60A	-	N-end	FXM85SX
IE2-WE2R 250 M8	225	6314 C3	70A	-	-	150	6313 C3	65A	-	N-end	FXM86DX

Series K21R Bearings with backstop

Type	Anti-friction bearing	D-end					Anti-friction bearing	N-end				Fixed bearing	Backstop (Ringspann)
		V-ring	γ-ring	Felt ring	Wave spring	Disc spring		V-ring	γ-ring	Wave spring	Felt ring		
K21R 63	6201 ZZ C3	-	-	11.5 x 19	-	-	6201 ZZ C3	-	-	32	12 x 22	without	without
K21R 71	6202 ZZ C3	-	-	14.5 x 21	-	-	6202 ZZ C3	-	-	35	15 x 24	without	without
(IE1-)K21R 80	6204 ZZ C3	-	-	19.5 x 26	-	-	6204 ZZ C3	-	-	47	20 x 32	without	without
(IE1-)K21R 90	6205 ZZ C3	-	-	24.5 x 35	-	-	6205 ZZ C3	-	-	52	25 x 40	without	without
(IE1-)K21R 100	6206 ZZ C3	-	-	29.2 x 40	-	-	6205 ZZ C3	-	-	52	25 x 40	without	without
(IE1-)K21R 100 LX	6206 ZZ C3	-	-	29.2 x 40	-	-	6206 ZZ C3	-	-	62	30 x 50	without	without
(IE1-)K21R 112 M	6206 ZZ C3	-	-	29.2 x 40	-	-	6206 ZZ C3	-	-	62	30 x 50	without	without
(IE1-)K21R 132 S2, 4T	6208 ZZ C3	-	-	39 x 60	-	-	6206 ZZ C3	-	-	62	30 x 50	without	without
(IE1-)K21R 132 S, SX2, M6, 8	6208 ZZ C3	-	RB40	-	80	-	6207 ZZ C3	-	RB35	-	-	N-end	FXM51DX
(IE1-)K21R 132 M4, MX6	6308 ZZ C3	-	RB40	-	90	-	6308 ZZ C3	-	RB40	-	-	N-end	FXM66DX
(IE1-)K21R 160 M, MX8	6309 ZZ C3	-	RB45	-	100	-	6308 ZZ C3	-	RB40	-	-	N-end	FXM66DX
(IE1-)K21R 160 MX2, L	6310 ZZ C3	-	RB50	-	110	-	6309 ZZ C3	-	RB45	-	-	N-end	FXM66DX
(IE1-)K21R 180 M4, L6, 8	6310 ZZ C3	-	RB50	-	110	-	6309 ZZ C3	-	RB45	-	-	N-end	FXM66DX
(IE1-)K21R 180 M2, L4	6310 C3	50A	-	110	-	6310 C3	50A	-	-	-	-	N-end	FXM86DX
(IE1-)K21R 200 L, LX6	6312 C3	60A	-	-	130	6310 C3	50A	-	-	-	-	N-end	FXM86DX
(IE1-)K21R 200 LX2	6312 C3	60A	-	-	130	6312 C3	60A	-	-	-	-	N-end	FXM85SX
(IE1-)K21R 225 M2	6312 C3	60A	-	-	130	6312 C3	60A	-	-	-	-	N-end	FXM85SX
(IE1-)K21R 225 S4, 8, M4, 6, 8	6313 C3	65A	-	-	140	6312 C3	60A	-	-	-	-	N-end	FXM85SX
(IE1-)K21R 250 M2	6313 C3	65A	-	-	140	6313 C3	65A	-	-	-	-	N-end	FXM86DX
(IE1-)K21R 250 M4, 6, 8	6314 C3	70A	-	-	150	6313 C3	65A	-	-	-	-	N-end	FXM86DX
(IE1-)K21R 280 S2, M2	6314 C3	70A	-	-	150	6314 C3	70A	-	-	-	-	N-end	FXM100SX
(IE1-)K21R 280 S4, 6, 6, M4, 6, 8	6316 C3	80A	-	-	170	6314 C3	70A	-	-	-	-	N-end	FXM100SX
(IE1-)K21R 315 S2, M2	6316 C3	80A	-	-	170	6316 C3	80A	-	-	-	-	N-end	FXM120SX
(IE1-)K21R 315 S4, 6, 8, M4, 6, 8	6317 C3	85A	-	-	180	6316 C3	80A	-	-	-	-	N-end	FXM120SX
(IE1-)K21R 315 MX2	6317 C3	-	RB85	-	180	6316 C3	80A	-	-	-	-	N-end	FXM120SX
(IE1-)K21R 315 MX4, 6, 8	6220 C3	-	RB100	-	180	6316 C3	80A	-	-	-	-	N-end	FXM120SX
(IE1-)K21R 315 MY2	6317 C3	-	RB85	-	180	6317 C3 ¹⁾	85A	-	-	-	-	N-end	FXM120SX
(IE1-)K21R 315 MY4, 6, 8	6320 C3	-	RB100	-	215	6317 C3 ¹⁾	85A	-	-	-	-	N-end	FXM120SX
(IE1-)K21R 315 L2, LX2	6317 C3	-	RB85	-	180	6317 C3 ¹⁾	85A	-	-	-	-	N-end	FXM120SX
(IE1-)K21R 315 L4, 6, 8 Lx4, 6, 8	6320 C3	-	RB100	-	215	6317 C3 ¹⁾	85A	-	-	-	-	N-end	FXM120SX
(IE1-)K22R 355 MY/M/MX/LY/L 2	6317 C3	-	RB85	-	180	6317 C3 ¹⁾	85A	-	-	-	-	N-end	FXM120SX
(IE1-)K22R 355 MY/M/MX/LY/L 4, 6, 8	6324 C3	-	RB120	-	260	6317 C3 ¹⁾	85A	-	-	-	-	N-end	FXM120SX

¹⁾ For types for vertical mounting Q317 C3; figures 18, 21
From size IE1-K20R 315 with relubrication device as standard

Series K20R

Bearings with backstop

Type	Anti-friction bearing	D-end					Anti-friction bearing	N-end					Fixed bearing	Backstop (Ringspann)
		V-ring	γ-ring	Felt ring	Wave spring	Disc spring		V-ring	γ-ring	Wave spring	Felt ring			
K20R 56	6201 ZZ C3	-	-	11.5 x 19	-	-	6201 ZZ C3	-	-	32	12 x 22	without	without	
K20R 63	6202 ZZ C3	-	-	14.5 x 21	-	-	6202 ZZ C3	-	-	35	15 x 24	without	without	
(IE1)-K20R 71	6204 ZZ C3	-	-	19.5 x 26	-	-	6204 ZZ C3	-	-	47	20 x 32	without	without	
(IE1)-K20R 80	6205 ZZ C3	-	-	24.2 x 35	-	-	6205 ZZ C3	-	-	52	25 x 40	without	without	
(IE1)-K20R 90	6205 ZZ C3	-	-	24.5 x 35	-	-	6205 ZZ C3	-	-	52	25 x 40	without	without	
(IE1)-K20R 100	6206 ZZ C3	-	-	29.2 x 40	-	-	6206 ZZ C3	-	-	62	30 x 50	without	without	
(IE1)-K20R 112 M2, 4, 6, 8	6207 ZZ C3	-	RB35	-	72	-	6207 ZZ C3	-	RB35	-	-	N-end	FXM51DX	
(IE1)-K20R 112 MX6, 8	6207 ZZ C3	-	RB35	-	72	-	6207 ZZ C3	-	RB35	-	-	N-end	FXM51DX	
(IE1)-K20R 132 S, M	6308 ZZ C3	-	RB40	-	90	-	6308 ZZ C3	-	RB40	-	-	N-end	FXM66DX	
(IE1)-K20R 160 S, M	6310 ZZ C3	-	RB50	-	110	-	6309 ZZ C3	-	RB45	-	-	N-end	FXM66DX	
(IE1)-K20R 180 S2, M2	6310 C3	50A	-	-	110	-	6310 C3	50A	-	-	-	N-end	FXM86DX	
(IE1)-K20R 180 S4, 6, 8, M4, 6, 8	6312 C3	60A	-	-	-	130	6310 C3	50A	-	-	-	N-end	FXM86DX	
(IE1)-K20R 200 M2, L2	6312 C3	60A	-	-	-	130	6312 C3	60A	-	-	-	N-end	FXM85SX	
(IE1)-K20R 200 M4, 6, 8, L4, 6, 8	6313 C3	65A	-	-	-	140	6312 C3	60A	-	-	-	N-end	FXM85SX	
(IE1)-K20R 225 M2	6313 C3	65A	-	-	-	140	6313 C3	65A	-	-	-	N-end	FXM86DX	
(IE1)-K20R 225 M4, 6, 8	6314 C3	70A	-	-	-	150	6313 C3	65A	-	-	-	N-end	FXM86DX	
(IE1)-K20R 250 S2, M2	6314 C3	70A	-	-	-	150	6314 C3	70A	-	-	-	N-end	FXM100SX	
(IE1)-K20R 250 S4, 6, 8, M4, 6, 8	6316 C3	80A	-	-	-	170	6314 C3	70A	-	-	-	N-end	FXM100SX	
(IE1)-K20R 280 S2, M2	6316 C3	80A	-	-	-	170	6316 C3	80A	-	-	-	N-end	FXM120SX	
(IE1)-K20R 280 S4, 6, 8, M4, 6, 8	6317 C3	85A	-	-	-	180	6316 C3	80A	-	-	-	N-end	FXM120SX	
(IE1)-K20R 315 S2	6317 C3	-	RB85	-	-	180	6316 C3	80A	-	-	-	N-end	FXM120SX	
(IE1)-K20R 315 S4, 6, 8	6220 C3	-	RB100	-	-	180	6316 C3	80A	-	-	-	N-end	FXM120SX	
(IE1)-K20R 315 M2, L2, LX2	6317 C3	-	RB85	-	-	180	6317 C3 ¹⁾	85A	-	-	-	N-end	FXM120SX	
(IE1)-K20R 315 M4, 6, 8, LX4, 6, 8	6320 C3	-	RB100	-	-	215	6317 C3 ¹⁾	85A	-	-	-	N-end	FXM120SX	

¹⁾ For types for vertical mounting Q317 C3; figures 18, 21
From size IE1-K20R 315 with relubrication device as standard

Terminal boxes

Standard design, sealed cable glands, power station design, VIK design

Type	Material	Adapter flange	Dimensions				Cable gland thread	Max. cable diameter	Terminal mounting	Number of terminals	Thread of terminal stud	Thread of protective conductor	Figure
			AG	LL	AH	BE							
Standard version													
			x	z	-	-	r	..r _{max}					
KA 05	Alu	-	92	92	-	-	M20 x 1.5	Ø 13 mm	K1M4	6	M4	M4	
KA 05	Alu	-	92	92	-	-	M25 x 1.5	Ø 17 mm	K1M4	6	M4	M4	
KA 05-13	Alu	-	104	112	-	-	M20 x 1.5	Ø 13 mm	K1M4	6	M4	M4	
KA 05-13	Alu	-	104	112	-	-	M25 x 1.5	Ø 17 mm	K1M4	6	M4	M4	
KA 05-13	Alu	-	104	112	-	-	M32 x 1.5	Ø 21 mm	K1M4	6	M4	M4	
25 A	Alu	-	156	145	-	-	M32 x 1.5	Ø 21 mm	SB 5/K1M5	6	M5	M6	01
25 A SS	GG-15	-	143	134	-	-	M32 x 1.5	Ø 21 mm	SB 5/K1M5	6	M5	M6	01
63/25 A	Alu	-	193	167	-	-	M40 x 1.5	Ø 28 mm	SB 5/K1M5	6	M5	M6	01
63 A	Alu	-	193	167	-	-	M40 x 1.5	Ø 28 mm	SB 6/K1M6	6	M6	M6	01
63 A	GG-15	-	174	162	-	-	M40 x 1.5	Ø 28 mm	SB 6/K1M6	6	M6	M6	01
63 A	Alu	-	193	167	-	-	M50 x 1.5	Ø 35 mm	SB 6/K1M6	6	M6	M6	01
63 A	GG-15	-	174	162	-	-	M50 x 1.5	Ø 35 mm	SB 6/K1M6	6	M6	M6	01
100 A	GG-15	-	213	207	-	-	M50 x 1.5	Ø 35 mm	SB 8	6	M8	M8	01
200/100 A	GG-15	-	282	242	-	-	M63 x 1.5	Ø 45 mm	SB 8	6	M8	M8	01
200 A	GG-15	-	282	242	-	-	M63 x 1.5	Ø 45 mm	SB 10	6	M10	M10	01
400 A	GG-15	-	315	294	-	-	M63 x 1.5	Ø 45 mm	SB 12	6	M12	M10	02
400 B	GG-15	-	415	340	265	-	M63 x 1.5	Ø 45 mm	KM 12	6	M12	LK	03
400 B	GG-15	-	415	340	265	-	M72 x 2	Ø 56.5 mm	KM 12	6	M12	LK	03
630 A	GG-15	straight	496	390	301	140	M72 x 2	Ø 56.5 mm	KLP 630-20	6	M20	LK	04G
630 A	GG-15	inclined	496	390	301	140	M72 x 2	Ø 56.5 mm	KLP 630-20	6	M20	LK	04S
1000 A	GG-15	straight	615	474	385	200	M72 x 2	Ø 56.5 mm	KLSO 1000	6	StS	LK	05G
1000 A	GG-15	inclined	615	474	385	200	M72 x 2	Ø 56.5 mm	KLSO 1000	6	StS	LK	05S
1000 A	GG-15	straight	615	474	385	200	M80 x 2	Ø 68 mm	KLSO 1000	6	StS	LK	05G
1000 A	GG-15	inclined	615	474	385	200	M80 x 2	Ø 68 mm	KLSO 1000	6	StS	LK	05S
Sealed cable glands													
VGK 200 A	GG-15	-	387	242	-	-	Ø 66	Ø 66 mm	SB 10	6	M10	M10	06
VGK 400 A	GG-15	-	422	296	-	-	Ø 95	Ø 95 mm	SB 12	6	M12	M10	06
Power station design													
25 A KA	GG-15	-	143	134	-	-	M32 x 1.5	Ø 21 mm	KL 155	6	M5	M6	07
63 A KA	GG-15	-	184	172	-	-	M40 x 1.5	Ø 28 mm	KL 155	6	M5	M6	07
63 A KA	GG-15	-	184	172	-	-	M40 x 1.5	Ø 28 mm	K1 M6	6	M6	M6	07
63/100 A KA	GG-15	-	223	214	-	-	M50 x 1.5	Ø 35 mm	K1 M6	6	M6	M6	07
100 A KA	GG-15	-	213	207	-	-	M50 x 1.5	Ø 35 mm	K1 M8	6	M8	M8	07
200 A KA	GG-15	-	285	258	-	-	M63 x 1.5	Ø 45 mm	K1 M10	6	M10	M10	07
200 B KA	GG-15	-	330	270	200	-	M63 x 1.5	Ø 45 mm	K1 M10	6	M10	LK	03
400 A KA	GG-15	-	315	306	-	-	M63 x 1.5	Ø 45 mm	KM 12	6	M12	M10	07
VIK design													
KA 05-13	Alu	-	104	112	-	-	M20 x 1.5	Ø 13 mm	K1M4	6	M4	M4	
KA 05-13	Alu	-	104	112	-	-	M25 x 1.5	Ø 17 mm	K1M4	6	M4	M4	
KA 05-13	Alu	-	104	112	-	-	M32 x 1.5	Ø 21 mm	K1M4	6	M4	M4	
25 AV Ex e II	GG-15	-	143	134	-	-	M32 x 1.5	Ø 21 mm	KL 155	6	M5	M6	07
63 AV Ex e II	GG-15	-	184	172	-	-	M40 x 1.5	Ø 28 mm	KL 155	6	M5	M6	07
100/63 AV Ex e IIC	GG-15	-	223	214	-	-	M40 x 1.5	Ø 28 mm	KM 8/6	6	M6	M6	08
100/63 AV Ex e IIC	GG-15	-	223	214	-	-	M50 x 1.5	Ø 35 mm	KM 8/6	6	M6	M6	08
200 A-SB Ex e IIC	GG-15	-	335	270	200	-	M50 x 1.5	Ø 35 mm	KM 10/8	6	LK	LK	09
200 A-SB Ex e IIC	GG-15	-	335	270	200	-	M63 x 1.5	Ø 45 mm	KM 10/8	6	LK	LK	09
400 A-SB Ex e IIC	GG-15	-	415	340	265	-	M63 x 1.5	Ø 45 mm	KM 16/12	6	LK	LK	09
630 A Ex e IIC	GG-15	straight	496	390	301	140	M75 x 1.5	Ø 45 mm	KLP 630-20	6	LK	LK	10G
630 A Ex e IIC	GG-15	inclined	496	390	301	140	M75 x 1.5	Ø 45 mm	KLP 630-20	6	LK	LK	10S
1000 A Ex e IIC	GG-15	straight	615	474	385	200	M80 x 1.5	Ø 68 mm	KLSO 1000	6	StS	LK	11G
1000 A Ex e IIC	GG-15	inclined	615	474	385	200	M80 x 1.5	Ø 68 mm	KLSO 1000	6	StS	LK	11S

StS... Busbars
LK... Terminal tabs

Standard design, sealed cable glands, power station design

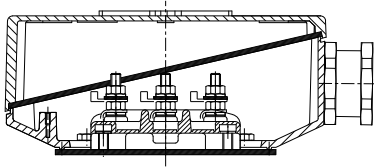

Figure 01

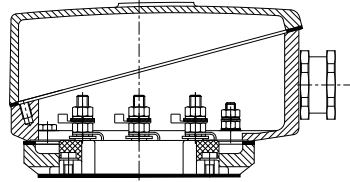
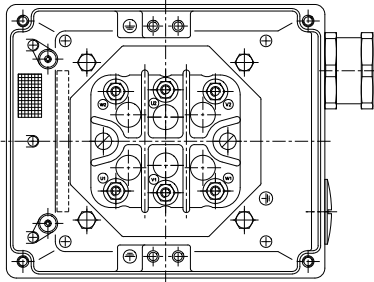

Figure 02

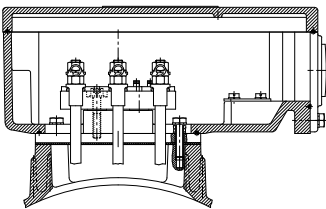
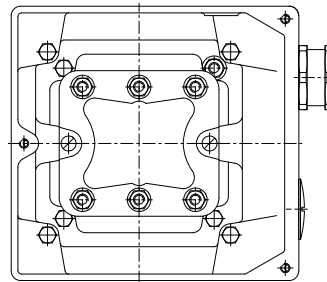

Figure 03

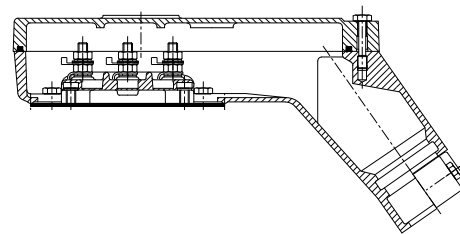
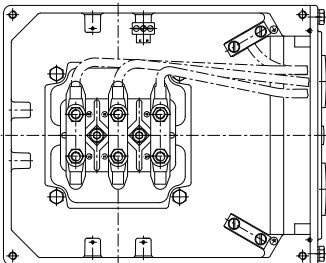

Figure 06

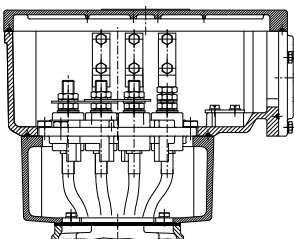
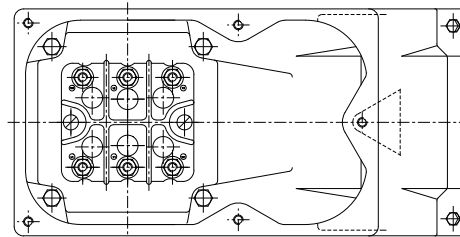

Figure 04G

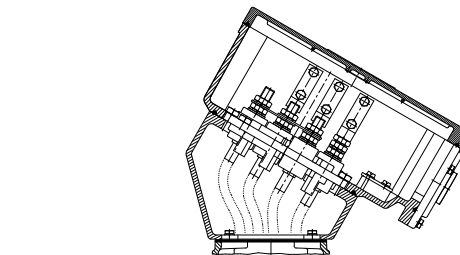
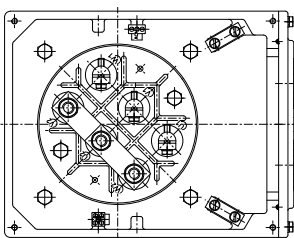
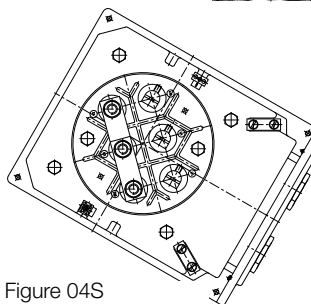

Figure 04S



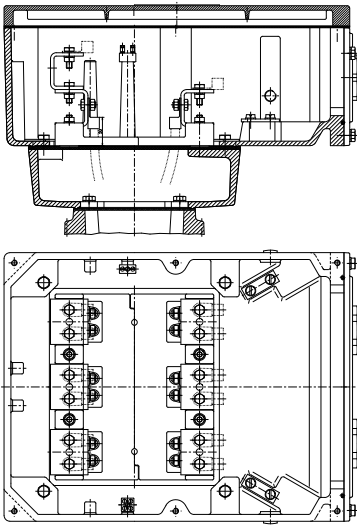

Figure 05G

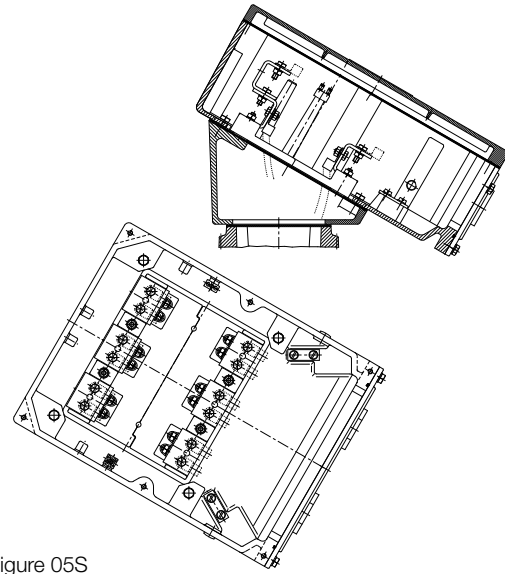

Figure 05S

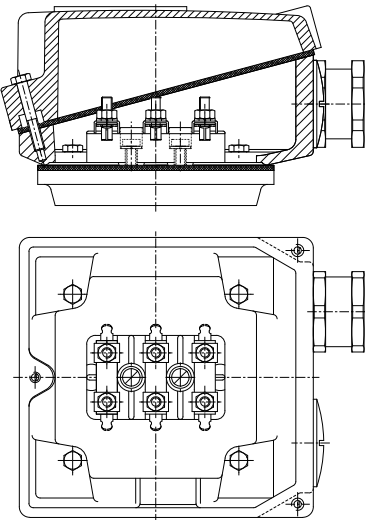

Figure 07

Dimensions

Flange dimensions

Flanges with threaded holes

Flange type to E DIN EN 50347	Flange type to DIN 42948	LA c ₁	M e ₁	N b ₁	P a ₁	S s ₁	T f ₁
FT 65	C 80	6,5	65	50	80	M5	2,5
FT 75	C 90	8	75	60	90	M5	2,5
FT 85	C 105	8,5	85	70	105	M6	2,5
FT 100	C 120	8	100	80	120	M6	3
FT 115	C 140	10	115	95	140	M8	3
FT 130	C 160	10	130	110	160	M8	3,5
FT 165	C 200	12	165	130	200	M10	3,5
FT 215	C 250	12	215	180	250	M12	4

Flanges with through-holes

Flange type to E DIN EN 50347	Flange type to DIN 42948	LA c ₁	M e ₁	N b ₁	P a ₁	S s ₁	T f ₁
FF 100	A 120	9	100	80	120	7	3
FF 115	A 140	9	115	95	140	9	3
FF 130	A 160	9	130	110	160	9	3,5
FF 165	A 200	10	165	130	200	11	3,5
FF 215	A 250	11	215	180	250	14	4
FF 265	A 300	12	265	230	300	14	4
FF 300	A 350	13	300	250	350	18	5
FF 350	A 400	15	350	300	400	18	5
FF 400	A 450	16	400	350	450	18	5
FF 500	A 550	18	500	450	550	18	5
FF 600	A 660	22	600	550	660	22	6
FF 740	A 800	25	740	680	800	22	6

According to DIN EN 50347, the different sizes of FF flanges possess through-holes, while FT flanges possess threaded holes. The flange designations A and C defined in DIN 42948 remain valid.

Flange assignments which deviate from the standard are specified in the flange assignment tables.

For tolerances for the dimension N (b₁), refer to the corresponding dimension tables
LA (c₁) depth of engagement

Flange variants

Type of construction IM B5/IM 3001

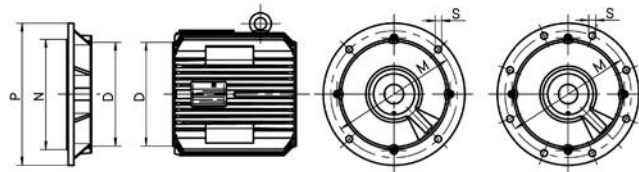

		IE3-W42R				IE3-W40R																							
		63	71	80	90																								
		IE3-W41R																											
D in mm		88	100	115	131	145	164	164	185	164	132...T	185	216	266	180	300	300	335	335	378	225	250	250	280 S2, M2, S4, S8	280 M4, S6, M6, M8	315 S2, M2, S4, M4	315	355 M, MY, L	
P	a ₁	120 ¹⁾	120 ¹⁾	120 ¹⁾	120 ¹⁾																								
N	b ₁	80	80	80	80																								
M	e₁	100	100	100	100																								
S	s ₁	7	7	7	7																								
P	a ₁	140	140 ¹⁾	140 ¹⁾																									
N	b ₁	95	95	95																									
M	e₁	115	115	115																									
S	s ₁	9	9	9																									
P	a ₁	160 ¹⁾	160	160 ¹⁾	160 ¹⁾	160 ¹⁾	160 ¹⁾	160 ¹⁾																					
N	b ₁	110	110	110	110	110	110	110																					
M	e₁	130	130	130	130	130	130	130																					
S	s ₁	9	9	9	9	9	9	9																					
P	a ₁	200		200	200 ¹⁾	200 ¹⁾	200 ¹⁾	200 ¹⁾	200 ¹⁾																				
N	b ₁	130		130	130	130	130	130	130																				
M	e₁	165		165	165	165	165	165	165	165																			
S	s ₁	11		11	11	11	11	11	11																				
P	a ₁	250 ¹⁾		250 ¹⁾	250	250	250	250	250	250																			
N	b ₁	180		180	180	180	180	180	180	180																			
M	e₁	215		215	215	215	215	215	215	215	215																		
S	s ₁	14		14	14	14	14	14	14	14																			
P	a ₁	300 ¹⁾			300					300	300 ²⁾	²⁾ Flange fixing by studs only on customer side ³⁾ For shaft diameter 42 mm: Flange fixing by studs only on customer side																	
N	b ₁	230			230					230	230																		
M	e₁	265			265					265	265																		
S	s ₁	14			14					14	14																		
P	a ₁	350							350	350	350																		
N	b ₁	250							250	250	250																		
M	e ₁	300							300	300	300																		
S	s ₁	18							18	18	18																		
P	a ₁	400 ⁴⁾							400	400	400	400 ⁶⁾	400 ⁷⁾	400 ⁷⁾	⁴⁾ KPR flange (with corners) ⁶⁾ For shaft diameter 55 mm ⁷⁾ For shaft diameter 60 mm														
N	b ₁	300							300	300	300	300	300	300															
M	e₁	350							350	350	350	350	350	350															
S	s ₁	18							18	18	18	18	18	18															
P	a ₁	450							450	450	450	450	450	450															
N	b ₁	350							350	350	350	350	350	350															
M	e₁	400							400	400	400	400	400	400															
S	s ₁	18							18	18	18	18	18	18															
P	a ₁	550												550	550	550	550												
N	b ₁	450												450	450	450	450												
M	e₁	500												500	500	500	500	500											
S	s ₁	18												18	18	18	18	18											
P	a ₁													660		660													
N	b ₁													550		550													
M	e₁													600		600													
S	s ₁													22		22													
P	a ₁															800													
N	b ₁															680													
M	e₁															740													
S	s ₁															22													

Flange variants

Type of construction IM 2202

IM B14

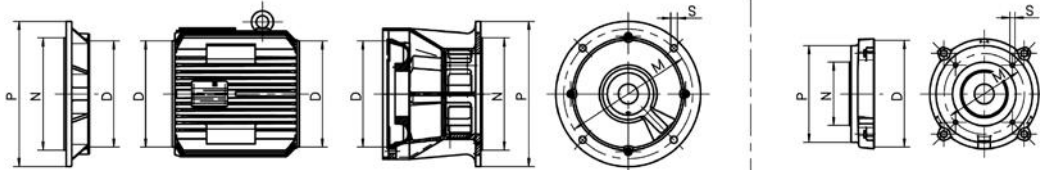

IE3-W4,R	63	71	80	90	100	100LX	112	112	132	SX2, M4, M6, MX6, S8, M8	160	180	200 L8	200	225 S4C, S8	225	250 M8	250	280 S2, M2, S4, S8	280 M4, S6, M6, M8	315 S2, M2, S4, M4	315	355 M, MY, L	
D in mm	88	100	115	131	145	164	164	185	185	216	266	300	300	335	335	378	378	428	428	488	488	530	624	
P a ₁										350	350	350												
N b ₁										250	250	250												
M e ₁										300	300	300												
S s ₁										18	18	18												
P a ₁										400	400	400	400											
N b ₁										300	300	300	300											
M e ₁										350	350	350	350											
S s ₁										18	18	18	18											
P a ₁														450	450									
N b ₁														350	350									
M e ₁														400	400									
S s ₁														18	18									
P a ₁																550	550	550	550					
N b ₁																450	450	450	450					
M e ₁																500	500	500	500					
S s ₁																18	18	18	18					
P a ₁																						660	660	
N b ₁																						550	550	
M e ₁																						600	600	
S s ₁																						22	22	

Type of construction IM B14 K, G

IE3-W41R	56	63	71	80	90	100	112	112	132...T	132	SX2, M4, M6, MX6, S8, M8	160	180	200 L8	200	225 S4C, S8	225	250 M8	250	280 S2, M2, S4, S8	280 M4, S6, M6, M8	315 S2, M2, S4, M4	315	355 M, MY, L
D in mm	88	100	115	131	145	164	164	185	164	185	216	266	300	300	335	335	378	378	428	428	488	488	530	624
P a ₁	80	90	105																					
N b ₁	50	60	70																					
M e ₁	65	75	85																					
S s ₁	M5	M5	M6																					
P a ₁	90	105	120	120	140	140	140		160	160														
N b ₁	60	70	80	80	95	95	95		110	110														
M e ₁	75	85	100	100	115	115	115		130	130														
S s ₁	M5	M6	M6	M6	M8	M8	M8		M8	M8														
P a ₁	105 ¹⁾	120	140	140	160	160	160	160	200	200														
N b ₁	70	80	95	95	110	110	110	110	130	130														
M e ₁	85	100	115	115	130	130	130	130	165	165														
S s ₁	M6	M6	M8	M8	M8	M8	M8	M8	M10	M10														
P a ₁	120	140	160	160	200	200	200	200	250	250	250	300												
N b ₁	80	95	110	110	130	130	130	130	180	180	180	230												
M e ₁	100	115	130	130	165	165	165	165	215	215	215	265												
S s ₁	M6	M8	M8	M8	M10	M10	M10	M10	M12	M12	M12	M12												

¹⁾ Protruding flange

Flange variants

Type of construction IM B5/IM 3001

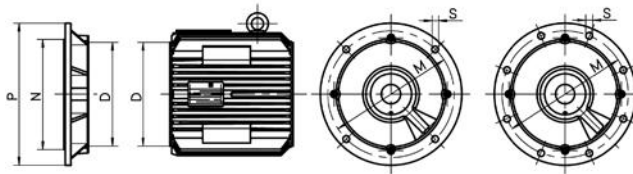

IE2-WE2R																													
		63	71	80	90	100							132	160 M4, M6	160 L4, L6	180 L6	180 M4	200 LX2, LX6	225 M4, M6	250 M4, M6				280 M6					
IE2-WE1R																													
		56	63	71	80	90	100	112	132...T	112	132	132 SX2, M4, MX6, M8	160 M8	160	180 M2, L4	200 L2, L6, L8	200 L4	225 M2, S4, S8	225 M4, M6, M8	250 M2, M8	250 M4, M6, M8	280	315S, M	315 MX	315 MY, L, LX	355 M, MY, L			
D in mm																													
		88	100	115	131	145	145	164	164	164	185	185	216	216	266	266	300	300	335	335	378	378	428	428	488	488	488	530	624
P	a ₁	120 ¹⁾	120 ¹⁾	120 ¹⁾	120 ¹⁾	120 ¹⁾																							
N	b ₁	80	80	80	80	80																							
M	e₁	100	100	100	100	100																							
S	s ₁	7	7	7	7	7																							
P	a ₁	140	140 ¹⁾	140 ¹⁾																									
N	b ₁	95	95	95																									
M	e₁	115	115	115																									
S	s ₁	9	9	9																									
P	a ₁	160 ¹⁾	160	160 ¹⁾	160 ¹⁾	160 ¹⁾	160 ¹⁾	160 ¹⁾	160 ¹⁾	160 ¹⁾	160 ¹⁾	160 ¹⁾	160 ¹⁾	160 ¹⁾															
N	b ₁	110	110	110	110	110	110	110	110	110	110	110	110	110															
M	e₁	130	130	130	130	130	130	130	130	130	130	130	130	130															
S	s ₁	9	9	9	9	9	9	9	9	9	9	9	9	9															
P	a ₁			200	200	200 ¹⁾	200 ¹⁾	200 ¹⁾	200 ¹⁾	200 ¹⁾	200 ¹⁾	200 ¹⁾	200 ¹⁾																
N	b ₁			130	130	130	130	130	130	130	130	130	130	130															
M	e₁			165	165	165	165	165	165	165	165	165	165	165															
S	s ₁			11	11	11	11	11	11	11	11	11	11	11															
P	a ₁				250 ¹⁾	250 ¹⁾	250	250	250	250	250	250	250	250															
N	b ₁				180	180	180	180	180	180	180	180	180	180	180														
M	e₁				215	215	215	215	215	215	215	215	215	215	215														
S	s ₁				14	14	14	14	14	14	14	14	14	14	14														
P	a ₁					300 ¹⁾	300 ¹⁾	300	300	300	300	300	300	300 ²⁾	300 ³⁾	²⁾ Flange fixing by studs only on customer side													
N	b ₁					230	230	230	230	230	230	230	230	230	230	³⁾ For shaft diameter 42 mm: Flange fixing by studs only on customer side													
M	e₁					265	265	265	265	265	265	265	265	265	265														
S	s ₁					14	14	14	14	14	14	14	14	14	14														
P	a ₁						350	350	350	350	350	350	350	350	350	350	350												
N	b ₁						250	250	250	250	250	250	250	250	250	250	250												
M	e₁						300	300	300	300	300	300	300	300	300	300	300												
S	s ₁						18	18	18	18	18	18	18	18	18	18	18												
P	a ₁							400 ⁴⁾	400 ⁴⁾	400	400	400	400	400 ⁶⁾	400 ⁷⁾	400 ⁷⁾	⁴⁾ KPR flange (with corners)												
N	b ₁							300	300	300	300	300	300	300	300	300	⁶⁾ For shaft diameter 55 mm												
M	e₁							350	350	350	350	350	350	350	350	350	⁷⁾ For shaft diameter 60 mm												
S	s ₁							18	18	18	18	18	18	18	18	18													
P	a ₁								450	450	450	450	450	450	450	450													
N	b ₁								350	350	350	350	350	350	350	350													
M	e₁								400	400	400	400	400	400	400	400													
S	s ₁								18	18	18	18	18	18	18	18													
P	a ₁									550	550	550	550	550	550	550	550	550	550										
N	b ₁									450	450	450	450	450	450	450	450	450	450										
M	e₁									500	500	500	500	500	500	500	500	500	500										
S	s ₁									18	18	18	18	18	18	18	18	18	18										
P	a ₁										660	660	660	660	660														
N	b ₁										550	550	550	550	550														
M	e₁										600	600	600	600	600														
S	s ₁										22	22	22	22	22														
P	a ₁																	800											
N	b ₁																	680											
M	e₁																	740											
S	s ₁																	22											

Flange variants

Type of construction IM 2202

IM B14

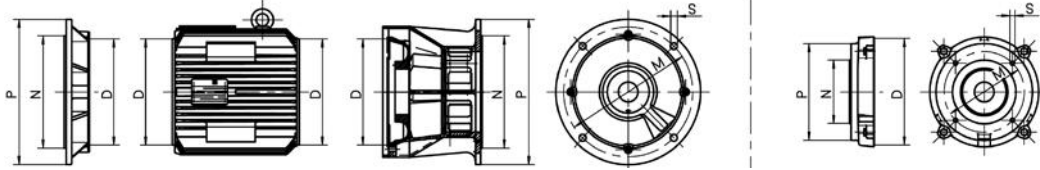

IE2-WE1R		IE2-WE2R	
	63		
	71		
	80		
	90		
	100		
	100LX		
	112		
	132		
	112		
	132		
	132 SX2, M4, MX6, M8		
	160 M8		
	160		
	180 M2, L4		
	200 L2, L6, L8		
	200 L4		
	225 M2, S4, S8		
	225 M4, M6, M8		
	250 M2, M8		
	250 M4, M6, M8		
	280		
	315 S, M		
	315 MX		
	315 MY, L, LX		
	355 M, MY, L		
D in mm	88	100	115
	131	145	164
	164	164	164
	185	185	185
	216	216	216
	266	266	266
	266	300	300
	300	300	300
	335	335	335
	335	378	378
	378	378	378
	428	428	428
	428	488	488
	488	488	488
	488	530	530
	624	624	624
P	a ₁		
N	b ₁	350	350
M	e ₁	250	250
S	s ₁	300	300
		18	18
P	a ₁		
N	b ₁	400	400
M	e ₁	300	300
S	s ₁	350	350
		18	18
P	a ₁		
N	b ₁	450	450
M	e ₁	350	350
S	s ₁	400	400
		18	18
P	a ₁		
N	b ₁	550	550
M	e ₁	450	450
S	s ₁	500	500
		18	18
P	a ₁		
N	b ₁	660	660
M	e ₁	550	550
S	s ₁	600	600
		22	22

Type of construction IM B14 K, G

IE2-WE1R		IE2-WE2R	
	56		
	63		
	71		
	80		
	90		
	100		
	100		
	112		
	132...T		
	112		
	132		
	132 SX2, M4, MX6, M8		
	160 M8		
	160		
	180 M2, L4		
	200 L2, L6, L8		
	200 L4		
	225 M2, S4, S8		
	225 M4, M6, M8		
	250 M2, M8		
	250 M4, M6, M8		
	280		
	280 M6		
	315 S, M		
	315 MX		
	315 MY, L, LX		
	355 M, MY, L		
D in mm	88	100	115
	131	145	164
	164	164	164
	185	185	185
	216	216	216
	266	266	266
	266	300	300
	300	300	300
	335	335	335
	335	378	378
	378	378	378
	428	428	428
	428	488	488
	488	488	488
	488	530	530
	624	624	624
P	a ₁	80	90
N	b ₁	50	60
M	e ₁	65	75
S	s ₁	M5	M5
		M6	M6
P	a ₁	90	105
N	b ₁	60	70
M	e ₁	75	85
S	s ₁	M5	M6
		M6	M6
P	a ₁	105 ¹⁾	120
N	b ₁	70	80
M	e ₁	85	100
S	s ₁	M6	M6
		M8	M8
P	a ₁	120	140
N	b ₁	80	95
M	e ₁	100	115
S	s ₁	M6	M8
		M8	M8
P	a ₁	140	160
N	b ₁	95	110
M	e ₁	115	130
S	s ₁	M8	M8
		M8	M8
P	a ₁	160	180
N	b ₁	110	130
M	e ₁	130	165
S	s ₁	M8	M10
		M8	M10
P	a ₁	180	200
N	b ₁	130	150
M	e ₁	165	215
S	s ₁	M10	M12
		M10	M12
P	a ₁	200	250
N	b ₁	150	180
M	e ₁	215	265
S	s ₁	M12	M12
		M12	M12

¹⁾ Protruding flange

Flange variants

Type of construction IM B5/IM 3001

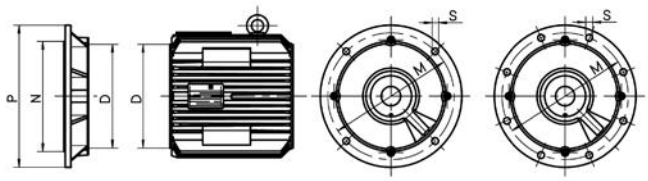

	(IE1-)K21R (IE1-)K22R (IE1-)KPER (IE1-)K11R	63	71	80	90	100	100 LX	112	132...T	132	132 M4, MX6	160	160	180 M4, L6, 8	180	200 L, LX6	200 LX2	225	250	280	315 S, M	315 MX	315 MY, L, LX	355 M, MY, L		
	(IE1-)K20R (IE1-)KPR	56	63	71	80	90	100	100	112	132	132	160	160	180	180	200	200	225	250	280	315 S	315 M	624			
	D in mm		100	115	131	145	145	164	164	164	185	185	216	216	266	266	300	300	335	335	378	428	488	488	530	624
P	a ₁	120 ¹⁾	120 ¹⁾	120 ¹⁾	120 ¹⁾	120 ¹⁾	120 ¹⁾																			
N	b ₁	80	80	80	80	80	80																			
M	e₁	100	100	100	100	100	100																			
S	s ₁	7	7	7	7	7	7																			
P	a ₁	140	140 ¹⁾	140 ¹⁾																						
N	b ₁	95	95	95																						
M	e₁	115	115	115																						
S	s ₁	9	9	9																						
P	a ₁	160 ¹⁾	160	160 ¹⁾	160 ¹⁾	160 ¹⁾	160 ¹⁾	160 ¹⁾	160 ¹⁾																	
N	b ₁	110	110	110	110	110	110	110	110																	
M	e₁	130	130	130	130	130	130	130	130																	
S	s ₁	9	9	9	9	9	9	9	9																	
P	a ₁			200	200	200 ¹⁾	200 ¹⁾	200 ¹⁾	200 ¹⁾	200 ¹⁾																
N	b ₁			130	130	130	130	130	130	130																
M	e₁			165	165	165	165	165	165	165																
S	s ₁			11	11	11	11	11	11	11																
P	a ₁			250 ¹⁾	250 ¹⁾	250	250	250	250	250	250															
N	b ₁			180	180	180	180	180	180	180	180															
M	e₁			215	215	215	215	215	215	215	215															
S	s ₁			14	14	14	14	14	14	14	14															
P	a ₁				300 ¹⁾	300 ¹⁾		300	300	300	300	300	300 ²⁾	300 ³⁾	2) Flange fixing by studs only on customer side											
N	b ₁				230	230		230	230	230	230	230	230	230	3) For shaft diameter 42 mm: Flange fixing by studs only on customer side											
M	e₁				265	265		265	265	265	265	265	265	265												
S	s ₁				14	14		14	14	14	14	14	14	14												
P	a ₁									350	350	350	350	350	350											
N	b ₁									250	250	250	250	250	250											
M	e₁									300	300	300	300	300	300											
S	s ₁									18	18	18	18	18	18											
P	a ₁												400 ⁴⁾	400 ⁴⁾	400	400	400	400 ⁶⁾	400 ⁷⁾	4) KPR flange (with corners)						
N	b ₁												300	300	300	300	300	300	300	6) For shaft diameter 55 mm						
M	e₁												350	350	350	350	350	350	350	7) For shaft diameter 60 mm						
S	s ₁												18	18	18	18	18	18	18							
P	a ₁													450	450	450	450	450								
N	b ₁													350	350	350	350	350								
M	e₁													400	400	400	400	400	400							
S	s ₁													18	18	18	18	18								
P	a ₁																	550	550	550	550					
N	b ₁																	450	450	450	450					
M	e₁																	500	500	500	500					
S	s ₁																	18	18	18	18					
P	a ₁																				660	660	660			
N	b ₁																				550	550	550			
M	e₁																				600	600	600			
S	s ₁																				22	22	22			
P	a ₁																								800	
N	b ₁																								680	
M	e₁																								740	
S	s ₁																								22	

Flange variants

Type of construction IM 2202

IM B14

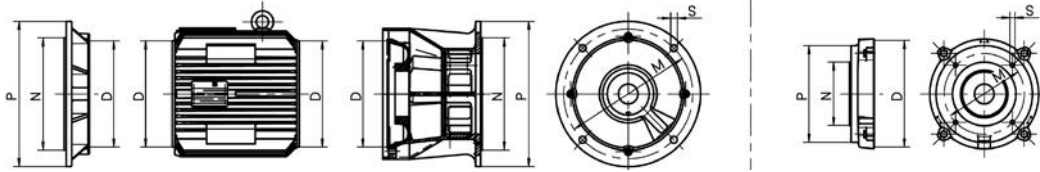

(IE1-)K21R, (IE1-)K22R (IE1-)KPER (IE1-)K11R	63	71	80	90	100	100 LX	112	112	132	132 M4, MX6	160	160	180 M4, L6, 8	180	200 L, LX6	200 LX2	225	250	280	315 S, M	315 MX	315 MY, L, LX	355 M, MY, L	
(IE1-)K20R (IE1-)KPR	56	63	71	80	90	100	100	112	112	132	132	160	160	180	180	200	200	225	250	280	315 S	315 M		
D in mm	88	100	115	131	145	164	164	164	185	216	216	266	266	300	300	335	335	378	428	488	488	530	624	
P	a ₁									350	350	350	350											
N	b ₁									250	250	250	250											
M	e ₁									300	300	300	300											
S	s ₁									18	18	18	18											
P	a ₁													400	400	400	400							
N	b ₁													300	300	300	300							
M	e ₁													350	350	350	350							
S	s ₁													18	18	18	18							
P	a ₁															450	450							
N	b ₁															350	350							
M	e ₁															400	400							
S	s ₁															18	18							
P	a ₁																	550	550					
N	b ₁																	450	450					
M	e ₁																	500	500					
S	s ₁																	18	18					
P	a ₁																			660	660			
N	b ₁																			550	550			
M	e ₁																			600	600			
S	s ₁																			22	22			

Type of construction IM B14 K, G

(IE1-)K21R, (IE1-)K22R (IE1-)KPER (IE1-)K11R	63	71	80	90	100	100 LX	112	132...T	132	132 M4, MX6	160	160	180 M4, L6, 8	180	200 L, LX6	200 LX2	225	250	280	315 S, M	315 MX	315 MY, L, LX	355 M, MY, L	
(IE1-)K20R (IE1-)KPR	56	63	71	80	90	100	100	112	132	132	160	160	160	180	180	200	200	225	250	280	315 S	315 M		
D in mm	88	100	115	131	145	164	164	164	185	216	216	266	266	300	300	335	335	378	428	488	488	530	624	
P	a ₁	80	90	105																				
N	b ₁	50	60	70																				
M	e ₁	65	75	85																				
S	s ₁	M5	M5	M6																				
P	a ₁	90	105	120	120	140	140	140	160	160														
N	b ₁	60	70	80	80	95	95	95	110	110														
M	e ₁	75	85	100	100	115	115	115	130	130														
S	s ₁	M5	M6	M6	M6	M8	M8	M8	M8	M8														
P	a ₁	105 ¹⁾	120	140	140	160	160	160	200	160	200													
N	b ₁	70	80	95	95	110	110	110	130	110	130													
M	e ₁	85	100	115	115	130	130	130	165	130	165													
S	s ₁	M6	M6	M8	M8	M8	M8	M8	M10	M8	M10													
P	a ₁	120	140	160	160	200	200	200	250	200	250	250	300	300										
N	b ₁	80	95	110	110	130	130	130	180	130	180	180	230	230										
M	e ₁	100	115	130	130	165	165	165	215	165	215	215	265	265										
S	s ₁	M6	M8	M8	M8	M10	M10	M10	M12	M10	M12	M12	M12	M12										

¹⁾ Protruding flange

**Energy-saving motor for Premium Efficiency IE3
Three-phase motors with squirrel-cage rotor**

with surface cooling, type of cooling IC 411, degree of protection IP 55
Size 56 to 160

Type of construction IM B3 [IM 1001]

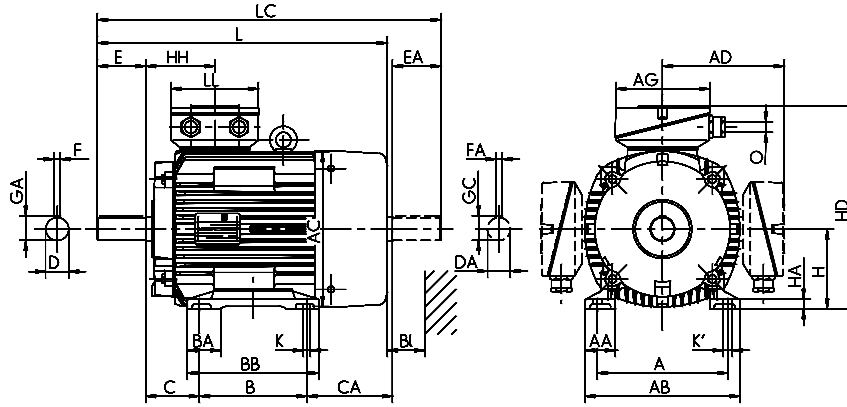

Type designation	Flange size	VIK										C	CA	D	DA	DB ¹⁾	E	EA	F	FA
		A	AA	AB	AC	AD	AD	B	BA	BB	B									
		b	n	f	g	g1	g1	a	m	e	w1	w2	d	d1	l	l1	u	u1		
IE3-W41R 56 G2	FF 100	90	18	110	109	98	117	71	-	86	36	52	9	-	M3	20	-	3	3	
IE3-W42R 63 K2, 4	FF 115	100	28	128	109	98	118	80	-	100	40	39	11	11	M4	23	23	4	4	
IE3-W41R 63 G2, 4, 6	FF 115	100	21	120	124	104	124	80	-	95	40	59	11	11	M4	23	23	4	4	
IE3-W42R 71 K2, 4, 6/GY6	FF 130	112	32	138	124	104	124	90	-	116	45	43.5	14	14	M5	30	30	5	5	
IE3-W41R 71 G8/GY2, 4, 6	FF 130	112	24	135	139	111	131	90	-	114	45	78	14	14	M5	30	30	5	5	
IE3-W42R 80 K2, 8	FF 165	125	38	168	139	111	131	100	-	125	50	63	19	19	M6	40	40	6	6	
IE3-W41R 80 K2, 4, 6/GY2/G8	FF 165	125	26	152	157	120	140	100	-	125	50	80	19	19	M6	40	40	6	6	
IE3-W41R 80 G2, 4, 6/GX4	FF 165	125	26	152	157	120	140	100	-	146	50	102	19	19	M6	40	40	6	6	
IE3-W42R 90 S2/SY8	FF 165	140	40	178	157	120	140	100	-	130	56	96	24	24	M8	50	50	8	6	
IE3-W41R 90 S2, 8/SY4, 6	FF 165	140	40	178	177	127	147	100	-	130	56	120	24	24	M8	50	50	8	6	
IE3-W41R 90 S4, 6	FF 165	140	40	178	177	127	147	100	-	130	56	125	24	24	M8	50	50	8	6	
IE3-W41R 90 LY2	FF 165	140	40	178	177	127	147	125	-	155	56	95	24	24	M8	50	50	8	6	
IE3-W41R 90 LX4	FF 165	140	40	178	177	127	147	125	-	155	56	150	24	24	M8	50	50	8	6	
IE3-W41R 90 L2, 4, 6, 8	FF 165	140	40	178	177	127	147	125	-	155	56	125	24	24	M8	50	50	8	6	
IE3-W41R 100 LY2, 8/L8	FF 215	160	42	193	196	137	156	140	-	175	63	102	28	28	M10	60	60	8	8	
IE3-W41R 100 L2/LY4/LX6/LW8	FF 215	160	42	193	196	137	156	140	-	175	63	136	28	28	M10	60	60	8	8	
IE3-W41R 100 L4/LX4	FF 215	160	42	193	196	137	156	140	-	175	63	166	28	28	M10	60	60	8	8	
IE3-W41R 100 LX8	FF 215	160	42	193	196	137	156	140	-	175	63	136	28	28	M10	60	60	8	8	
IE3-W41R 100 LZ4, LW4	FF 215	160	42	193	196	137	156	140	-	175	63	206	28	28	M10	60	60	8	8	
IE3-W41R 112 M2, 8/MV6	FF 215	190	52	225	196	136	156	140	-	180	70	159	28	28	M10	60	60	8	8	
IE3-W41R 112 MY2	FF 215	190	52	225	196	136	156	140	-	180	70	129	28	28	M10	60	60	8	8	
IE3-W41R 112 MZ6, 8	FF 215	190	52	225	196	137	156	140	-	180	70	199	28	28	M10	60	60	8	8	
IE3-W40R 112 M2, W41R 112 MW4	FF 215	190	45	226	217	178	189	140	42	172	70	192	28	28	M10	60	60	8	8	
IE3-W41R 112 M4	FF 215	190	45	226	217	178	189	140	42	172	70	242	28	28	M10	60	60	8	8	
IE3-W41R 132 S2T	FF 265	216	50	256	196	155	155	140	-	180	89	129	38	28	M12	80	60	10	8	
IE3-W41R 132 S2, W42R 132 S8	FF 265	216	50	256	217	178	189	140	55	180	89	173	38	32	M12	80	80	10	10	
IE3-W41R 132 S6	FF 265	216	50	256	217	178	189	140	55	180	89	223	38	32	M12	80	80	10	10	
IE3-W41R 132 SX2	FF 265	216	50	256	258	199	210	140	47	180	89	176	38	32	M12	80	80	10	10	
IE3-W41R 132 S4	FF 265	216	50	256	258	199	210	140	47	180	89	186	38	32	M12	80	80	10	10	
IE3-W41R 132 M4	FF 265	216	50	256	258	199	210	178	47	218	89	236	38	38	M12	80	80	10	10	
IE3-W41R 132 M6	FF 265	216	50	256	258	199	210	178	55	218	89	138	38	32	M12	80	80	10	10	
IE3-W41R 132 MX6	FF 265	216	50	256	258	199	210	178	55	218	89	236	38	38	M12	80	80	10	10	
IE3-W41R 132 S8	FF 265	216	50	256	258	199	210	140	55	180	89	176	38	32	M12	80	80	10	10	
IE3-W41R 132 M8	FF 265	216	50	256	258	199	210	178	55	218	89	138	38	32	M12	80	80	10	10	
IE3-W41R 160 M2	FF 300	254	55	296	313	242	275	210	56	257	108	148	42	42	M16	110	110	12	12	
IE3-W41R 160 MX2	FF 300	254	55	296	313	242	275	210	56	257	108	186	42	42	M16	110	110	12	12	
IE3-W41R 160 L2	FF 300	254	55	296	313	242	275	254	60	301	108	192	42	42	M16	110	110	12	12	
IE3-W41R 160 M4	FF 300	254	55	296	313	242	275	210	56	257	108	148	42	42	M16	110	110	12	12	
IE3-W41R 160 L4C	FF 300	254	55	296	313	242	275	254	60	301	108	192	42	42	M16	110	110	12	12	
IE3-W41R 160 M6	FF 300	254	55	296	313	242	275	210	56	257	108	186	42	42	M16	110	110	12	12	
IE3-W41R 160 L6C	FF 300	254	55	296	313	242	275	254	60	301	108	192	42	42	M16	110	110	12	12	
IE3-W41R 160 M8	FF 300	254	55	296	313	242	275	210	60	257	108	148	42	42	M16	110	110	12	10	
IE3-W41R 160 MX8	FF 300	254	55	296	313	242	275	210	56	257	108	148	42	42	M16	110	110	12	12	
IE3-W41R 160 L8	FF 300	254	55	296	313	242	275	254	60	301	108	192	42	42	M16	110	110	12	12	

¹⁾ Centre holes to DIN 332-DS

Energy-saving motor for Premium Efficiency IE3 Three-phase motors with squirrel-cage rotor

with surface cooling, type of cooling IC 411, degree of protection IP 55
Size 56 to 160

Type of construction IM B35 [IM 2001]

Flange dimensions, see page 2/109

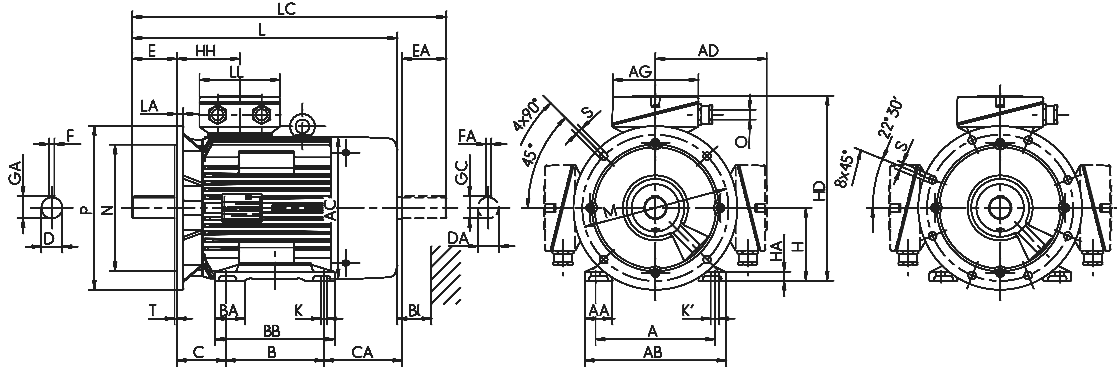

Type designation	GA	GC	H	HA	HD	HD ¹⁾	HD	HH	K	K'	L	LC	TB Type	AG	LL	TB Type	AG	LL	O	Hole	BI
	t	t1	h	c	p	p	p	A	s	s'	k	k1		x	z	VIK	x	z	-		BI
IE3-W41R 56 G2	10	10.2	56	7	154	***	174	58	6	6	176	199	KA 05	92	92	KA 05-13	104	112	M20 x 1.5	4L	14
IE3-W42R 63 K2, 4	13	12.5	63	10	161	***	181	58	8	8	179	205	KA 05	92	92	KA 05-13	104	112	M20 x 1.5	4L	14
IE3-W41R 63 G4/G6	13	12.5	63	7.5	167	***	187	61	7	7	199	225	KA 05	92	92	KA 05-13	104	112	M20 x 1.5	4L	14
IE3-W42R 71 K2/K4/KY6	16	16	71	11	175	***	195	61	8	8	206	239	KA 05	92	92	KA 05-13	104	112	M20 x 1.5	4L	14
IE3-W41R 71 G8/GY4, 6	16	16	71	8	182	***	202	67	7	7	238	273	KA 05	92	92	KA 05-13	104	112	M20 x 1.5	4L	14
IE3-W42R 80 K2/K8	22	21.5	80	12	191	***	211	67	10	10	249	293	KA 05	92	92	KA 05-13	104	112	M20 x 1.5	4L	16
IE3-W41R 80 K2, 4, 6/GY2/G8	22	21.5	80	9	200	***	220	70	10	10	265	310	KA 05	92	92	KA 05-13	104	112	M20 x 1.5	4L	16
IE3-W41R 80 G2, 4, 6/GX4	22	21.5	80	9	200	***	220	70	10	10	287	332	KA 05	92	92	KA 05-13	104	112	M20 x 1.5	4L	16
IE3-W42R 90 S2/SY8	27	24.5	90	14	210	***	230	70	10	10	297	352	KA 05	92	92	KA 05-13	104	112	M25 x 1.5	4L	16
IE3-W41R 90 S2, 8/SY4, 6	27	24.5	90	10.5	217	***	237	75	10	10	321	376	KA 05	92	92	KA 05-13	104	112	M25 x 1.5	4L	18
IE3-W41R 90 S4, 6	27	24.5	90	10.5	217	***	237	75	10	10	351	406	KA 05	92	92	KA 05-13	104	112	M25 x 1.5	4L	18
IE3-W41R 90 LY2	27	24.5	90	11	217	***	237	75	10	10	321	376	KA 05	92	92	KA 05-13	104	112	M25 x 1.5	4L	18
IE3-W41R 90 LX4	27	24.5	90	10.5	217	***	237	75	10	10	376	431	KA 05	92	92	KA 05-13	104	112	M25 x 1.5	4L	18
IE3-W41R 90 L2, 4, 6, 8	27	24.5	90	10.5	217	***	237	75	10	10	351	406	KA 05	92	92	KA 05-13	104	112	M25 x 1.5	4L	18
IE3-W41R 100 LY2, 8/L8	31	31	100	13	236	***	256	77	12	12	357	425	KA 05	92	92	KA 05-13	104	112	M25 x 1.5	4L	20
IE3-W41R 100 L2/LY4/LX6/LW8	31	31	100	13	236	***	256	77	12	12	391	459	KA 05	92	92	KA 05-13	104	112	M25 x 1.5	4L	20
IE3-W41R 100 L4/LX4	31	31	100	13	236	***	256	77	12	12	421	489	KA 05	92	92	KA 05-13	104	112	M25 x 1.5	4L	20
IE3-W41R 100 LX8	31	31	100	13	236	***	256	77	12	12	391	459	KA 05	92	92	KA 05-13	104	112	M25 x 1.5	4L	20
IE3-W41R 100 LZ4	31	31	100	18	236	***	256	77	12	12	461	529	KA 05	92	92	KA 05-13	104	112	M25 x 1.5	4L	20
IE3-W41R 112 M2/MV6/M8	31	31	112	18	248	***	268	77	12	12	421	489	KA 05	92	92	KA 05-13	104	112	M25 x 1.5	4L	20
IE3-W41R 112 MY2	31	31	112	18	248	***	268	77	12	12	391	459	KA 05	92	92	KA 05-13	104	112	M25 x 1.5	4L	20
IE3-W41R 112 MZ6, 8	31	31	112	18	248	***	268	77	12	12	461	529	KA 05	92	92	KA 05-13	104	112	M25 x 1.5	4L	20
IE3-W40R 112 M2, W41R 112 MW4	31	31	112	15	290	236.5	297	108	12	12	459	522	25 A	156	145	25 AV	156	145	M32 x 1.5	4L	35
IE3-W41R 112 M4	31	31	112	15	290	236.5	297	108	12	12	509	572	25 A	156	145	25 AV	156	145	M32 x 1.5	4L	35
IE3-W41R 132 S2T	41	31	132	18	287	***	287	105	12	12	460	528	KA 05-13	104	112	KA 05-13	104	112	M25 x 1.5	4L	20
IE3-W41R 132 S2	41	35	132	16	310	256.5	317	108	12	12	479	562	25 A	156	145	25 AV	156	145	M32 x 1.5	4L	35
IE3-W41R 132 S6	41	35	132	16	310	256.5	317	108	12	12	529	612	25 A	156	145	25 AV	156	145	M32 x 1.5	4L	35
IE3-W41R 132 SX2	41	41	132	15	331	279	338	114	12	12	481	565	25 A	156	145	25 AV	156	145	M32 x 1.5	4L	35
IE3-W41R 132 S4	41	41	132	15	331	279	338	114	12	12	529	613	25 A	156	145	25 AV	156	145	M32 x 1.5	4L	35
IE3-W41R 132 M4	41	41	132	15	331	279	338	114	12	12	579	663	25 A	156	145	25 AV	156	145	M32 x 1.5	4L	35
IE3-W41R 132 M6	41	41	132	16	331	279	338	114	12	12	481	565	25 A	156	145	25 AV	156	145	M32 x 1.5	4L	35
IE3-W41R 132 MX6	41	41	132	15	331	279	338	114	12	12	579	663	25 A	156	145	25 AV	156	145	M32 x 1.5	4L	35
IE3-W41R 132 S8	41	35	132	16	331	279	338	114	12	12	481	565	25 A	156	145	25 AV	156	145	M32 x 1.5	4L	35
IE3-W41R 132 M8	41	41	132	16	331	279	338	114	12	12	481	565	25 A	156	145	25 AV	156	145	M32 x 1.5	4L	35
IE3-W41R 160 M2	45	45	160	18	402	336	435	138	15	20	571	686	63 A	193	167	100/63 AV	223	214	M40 x 1.5	4L	35
IE3-W41R 160 MX2	45	45	160	18	402	336	435	138	15	20	609	724	63 A	193	167	100/63 AV	223	214	M40 x 1.5	4L	35
IE3-W41R 160 L2	45	45	160	18	402	336	435	138	15	20	659	774	63 A	193	167	100/63 AV	223	214	M40 x 1.5	4L	35
IE3-W41R 160 M4	45	45	160	18	402	336	435	138	15	20	571	686	63 A	193	167	100/63 AV	223	214	M40 x 1.5	4L	35
IE3-W41R 160 L4C	45	45	160	18	402	336	435	138	15	20	659	774	63 A	193	167	100/63 AV	223	214	M40 x 1.5	4L	35
IE3-W41R 160 M6	45	45	160	18	402	336	435	138	15	20	609	724	63 A	193	167	100/63 AV	223	214	M40 x 1.5	4L	35
IE3-W41R 160 L6C	45	45	160	18	402	336	435	138	15	20	659	774	63 A	193	167	100/63 AV	223	214	M40 x 1.5	4L	35
IE3-W41R 160 M8	45	45	160	18	402	336	435	138	15	15	571	724	63 A	193	167	100/63 AV	223	214	M40 x 1.5	4L	35
IE3-W41R 160 MX8	45	45	160	18	402	336	435	138	15	20	571	724	63 A	193	167	100/63 AV	223	214	M40 x 1.5	4L	35
IE3-W41R 160 L8	45	45	160	18	402	336	435	138	15	20	659	774	63 A	193	167	100/63 AV	223	214	M40 x 1.5	4L	35

¹⁾ Terminal box left/right

*** upon request

**Energy-saving motor for Premium Efficiency IE3
Three-phase motors with squirrel-cage rotor**

with surface cooling, type of cooling IC 411, degree of protection IP 55
Size 180 to 280

Type of construction IM B3 [IM 1001]

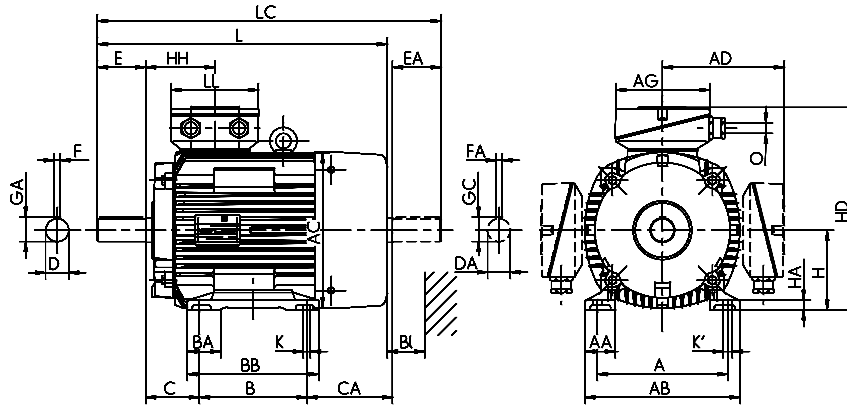

Type designation	Flange size	A	AA	AB	AC	AD	AD	B	BA	BB	C	CA	D	DA	DB ¹⁾	E	EA	F	FA
		b	n	f	g	g1	g1	a	m	e	w1	w2	d	d1		l	l1	u	u1
IE3-W41R 180 M2C	FF 300	279	62	328	351	261	294	241	65	288	121	214	48	48	M16	110	110	14	14
IE3-W41R 180 M4	FF 300	279	62	328	351	261	294	241	65	288	121	214	48	48	M16	110	110	14	14
IE3-W41R 180 L4	FF 300	279	62	328	351	261	294	279	65	326	121	226	48	48	M16	110	110	14	14
IE3-W41R 180 L6C	FF 300	279	62	328	351	261	294	279	65	326	121	176	48	48	M16	110	110	14	14
IE3-W41R 180 L8	FF 300	279	62	328	351	261	294	279	65	326	121	226	48	48	M16	110	110	14	14
IE3-W41R 200 L2	FF 350	318	70	372	390	300	378	305	70	360	133	233	55	55	M20	110	110	16	16
IE3-W41R 200 LX2C	FF 350	318	70	372	390	300	378	305	70	360	133	233	55	55	M20	110	110	16	16
IE3-W41R 200 L4C	FF 350	318	70	372	390	300	378	305	70	360	133	233	55	55	M20	110	110	16	16
IE3-W41R 200 L6	FF 350	318	70	372	390	300	378	305	70	360	133	233	55	55	M20	110	110	16	16
IE3-W41R 200 LX6C	FF 350	318	70	372	390	300	378	305	70	360	133	233	55	55	M20	110	110	16	16
IE3-W41R 200 L8	FF 350	318	70	372	351	261	294	305	70	360	133	188	55	48	M20	110	110	16	14
IE3-W41R 225 M2	FF 400	356	75	413	440	324	406	311	75	368	149	267	55	55	M20	110	110	16	16
IE3-W41R 225 S4C	FF 400	356	75	413	390	300	378	286	75	343	149	286	60	55	M20	140	110	18	16
IE3-W41R 225 M4	FF 400	356	75	413	440	324	406	311	75	368	149	267	60	55	M20	140	110	18	16
IE3-W41R 225 M6	FF 400	356	75	413	440	324	406	311	75	368	149	267	60	55	M20	140	110	18	16
IE3-W41R 225 S8	FF 400	356	75	413	390	300	378	286	75	343	149	236	60	55	M20	140	110	18	16
IE3-W41R 225 M8	FF 400	356	75	413	440	324	406	311	75	368	149	267	60	55	M20	140	110	18	16
IE3-W41R 250 M2	FF 500	406	84	469	490	386	399	349	84	374	168	275	60	55	M20	140	110	18	16
IE3-W41R 250 M4	FF 500	406	84	469	490	386	399	349	84	412	168	275	65	55	M20	140	110	18	16
IE3-W41R 250 M6	FF 500	406	84	469	490	386	399	349	84	412	168	275	65	55	M20	140	110	18	16
IE3-W41R 250 M8	FF 500	406	84	471	440	386	406	349	84	412	168	260	65	55	M20	140	110	18	16
IE3-W41R 280 S2	FF 500	457	94	522	490	386	399	368	96	431	190	234	65	65	M20	140	140	18	18
IE3-W41R 280 M2	FF 500	457	94	522	490	386	399	419	96	482	190	234	65	65	M20	140	140	18	18
IE3-W41R 280 S4	FF 500	457	94	522	490	386	399	368	96	431	190	234	75	65	M20	140	140	20	18
IE3-W41R 280 M4	FF 500	457	94	522	550	416	460	419	94	482	190	384	75	65	M20	140	140	20	18
IE3-W41R 280 S6	FF 500	457	94	522	550	416	460	368	94	431	190	380	75	65	M20	140	140	20	18
IE3-W41R 280 M6	FF 500	457	94	522	550	416	460	419	94	482	190	384	75	65	M20	140	140	20	18
IE3-W41R 280 S8	FF 500	457	94	522	550	416	460	368	94	431	190	380	75	65	M20	140	140	20	18
IE3-W41R 280 M8	FF 500	457	94	522	550	416	460	419	94	482	190	384	75	65	M20	140	140	20	18

¹⁾ Centre holes to DIN 332-DS

Energy-saving motor for Premium Efficiency IE3 Three-phase motors with squirrel-cage rotor

with surface cooling, type of cooling IC 411, degree of protection IP 55
Size 180 to 280

Type of construction IM B35 [IM 2001]

Flange dimensions, see page 2/109

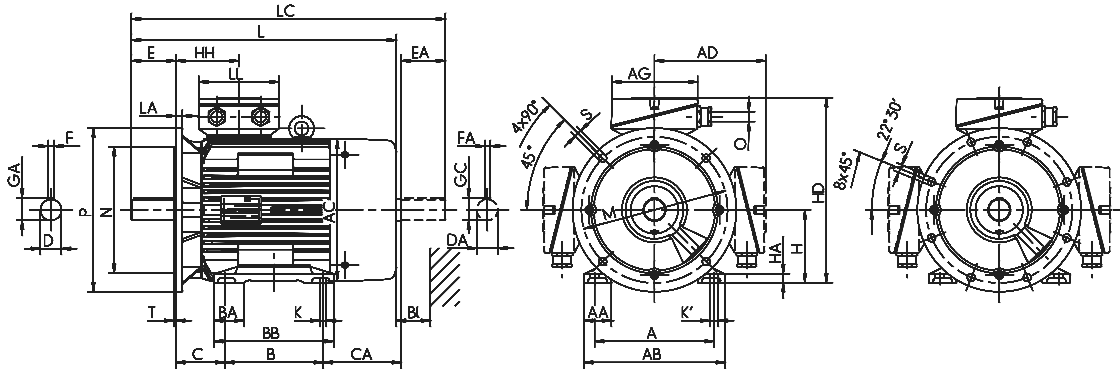

Type designation	GA	GC	H	HA	HD	HD ^{**}	HD	HH	K	K'	L	LC	TB Type	AG	LL	TB Type	AG	LL	O	Hole pattern	BI
	t	t1	h	c	p	p	p	A	s	s'	k	k1		x	z	VIK	x	z	-		BI
IE3-W41R 180 M2C	51.5	51.5	180	20	441	369	474	147	15	20	680	796	63 A	193	167	100/63 AV	223	214	M40 x 1.5	4L	35
IE3-W41R 180 M4	51.5	51.5	180	20	441	369	474	147	15	20	680	796	63 A	193	167	100/63 AV	223	214	M40 x 1.5	4L	35
IE3-W41R 180 L4	51.5	51.5	180	20	441	369	474	147	15	20	730	846	63 A	193	167	100/63 AV	223	214	M40 x 1.5	4L	35
IE3-W41R 180 L6C	51.5	51.5	180	20	441	369	474	147	15	20	680	796	63 A	193	167	100/63 AV	223	214	M40 x 1.5	4L	35
IE3-W41R 180 L8	51.5	51.5	180	20	441	369	474	147	15	20	680	796	63 A	193	167	100/63 AV	223	214	M40 x 1.5	4L	35
IE3-W41R 200 L2	59	59	200	22	500	417	577	168	19	25	767	891	100 A	213	207	200 A-SB	335	270	M50 x 1.5	4L	40
IE3-W41R 200 LX2C	59	59	200	22	500	417	577	168	19	25	767	891	100 A	213	207	200 A-SB	335	270	M50 x 1.5	4L	40
IE3-W41R 200 L4C	59	59	200	22	500	417	577	168	19	25	767	891	100 A	213	207	200 A-SB	335	270	M50 x 1.5	4L	35
IE3-W41R 200 L6	59	59	200	22	500	417	577	168	19	25	767	891	100 A	213	207	200 A-SB	335	270	M50 x 1.5	4L	35
IE3-W41R 200 LX6C	59	59	200	22	500	417	577	168	19	25	767	891	100 A	213	207	200 A-SB	335	270	M50 x 1.5	4L	35
IE3-W41R 200 L8	59	51.5	200	22	461	389	494	147	19	25	730	846	63 A	193	167	100/63 AV	223	214	M50 x 1.5	4L	35
IE3-W41R 225 M2	59	59	225	25	549	450	626	177	19	25	832	947	100 A	213	207	200 A-SB	335	270	M50 x 1.5	8L	45
IE3-W41R 225 S4C	64	59	225	25	527	442	604	168	19	25	847	971	100 A	213	207	200 A-SB	335	270	M50 x 1.5	8L	40
IE3-W41R 225 M4	64	59	225	25	549	450	626	177	19	25	912	1027	100 A	213	207	200 A-SB	335	270	M50 x 1.5	8L	45
IE3-W41R 225 M6	64	59	225	25	549	450	626	177	19	25	912	1027	100 A	213	207	200 A-SB	335	270	M50 x 1.5	8L	45
IE3-W41R 225 S8	64	59	225	25	527	442	604	168	19	25	797	921	100 A	213	207	200 A-SB	335	270	M50 x 1.5	8L	40
IE3-W41R 225 M8	64	59	225	25	549	450	626	177	19	25	862	977	100 A	213	207	200 A-SB	335	270	M50 x 1.5	8L	45
IE3-W41R 250 M2	64	59	250	28	636	507	652	206	24	30	924	1072	200 A	282	242	200 A-SB	335	270	M63 x 1.5	8L	55
IE3-W41R 250 M4	69	59	250	28	636	507	652	206	24	30	924	1072	200 A	282	242	200 A-SB	335	270	M63 x 1.5	8L	50
IE3-W41R 250 M6	69	59	250	28	636	507	652	206	24	30	924	1072	200 A	282	242	200 A-SB	335	270	M63 x 1.5	8L	50
IE3-W41R 250 M8	69	59	250	28	636	484	652	177	24	30	912	1112	200 A	282	242	200 A-SB	335	270	M63 x 1.5	8L	50
IE3-W41R 280 S2	69	69	280	32	666	537	682	206	24	30	924	1072	200 A	282	242	200 A-SB	335	270	M63 x 1.5	8L	55
IE3-W41R 280 M2	69	69	280	32	666	537	682	206	24	30	970	1118	200 A	282	242	200 A-SB	335	270	M63 x 1.5	8L	55
IE3-W41R 280 S4	79.5	69	280	32	666	537	682	206	24	30	970	1118	200 A	282	242	200 A-SB	335	270	M63 x 1.5	8L	50
IE3-W41R 280 M4	79.5	69	280	40	696	575	712	211	24	30	1105	1273	200 A	282	242	200 A-SB	335	270	M63 x 1.5	8L	55
IE3-W41R 280 S6	79.5	69	280	40	696	575	712	211	24	30	1050	1218	200 A	282	242	200 A-SB	335	270	M63 x 1.5	8L	55
IE3-W41R 280 M6	79.5	69	280	40	696	575	712	211	24	30	1105	1273	200 A	282	242	200 A-SB	335	270	M63 x 1.5	8L	55
IE3-W41R 280 S8	79.5	69	280	40	696	537	712	211	24	30	1050	1218	200 A	282	242	200 A-SB	335	270	M63 x 1.5	8L	55
IE3-W41R 280 M8	79.5	69	280	40	696	575	712	211	24	30	1105	1273	200 A	282	242	200 A-SB	335	270	M63 x 1.5	8L	55

** Terminal box left/right

**Energy-saving motor for Premium Efficiency IE3
Three-phase motors with squirrel-cage rotor**

with surface cooling, type of cooling IC 411, degree of protection IP 55
Size 315

Type of construction IM B3 [IM 1001]

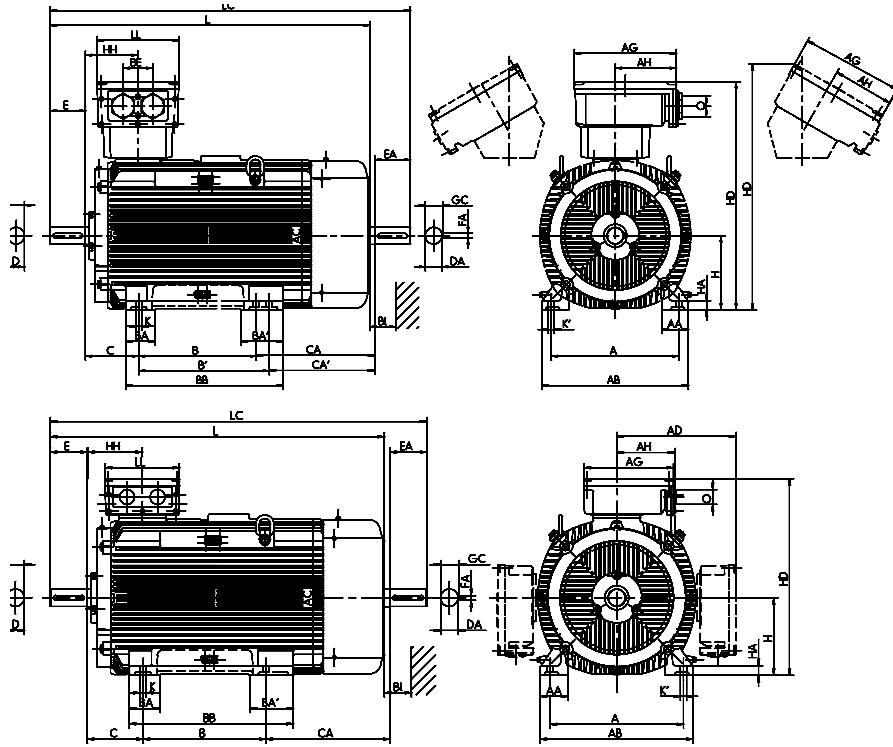

Type designation	Flange size	A	AA	AB	AC	AD	AD	B	BA	BA'	BB	C	CA	D	DA	DB ¹⁾	E	EA	F	FA
		b	n	f	g	g1	g1	a	m	m1	e	w1	w2	d	d1		l	l1	u	u1
IE3-W41R 315 S2	FF 600	508	126	590	550	416	460	406	120	-	503	216	316	65	65	M20	140	140	18	18
IE3-W41R 315 M2	FF 600	508	126	590	550	416	460	457	120	150	554	216	320	65	65	M20	140	140	18	18
IE3-W41R 315 MX2	FF 600	508	110	590	610	494	498	457	120	150	554	216	495	65	65	M20	140	140	18	18
IE3-W41R 315 MY2	FF 600	508	110	590	610	494	498	457	120	-	573	216	495	65	65	M20	140	140	18	18
IE3-W41R 315 L2	FF 600	508	110	590	610	494	498	508	120	-	624	216	564	65	65	M20	140	140	18	18
IE3-W41R 315 LX2	FF 600	508	110	590	610	494	498	508	120	-	624	216	684	65	65	M20	140	140	18	18
IE3-W41R 315 S4	FF 600	508	126	590	550	416	460	406	120	150	503	216	316	80	70	M20	170	140	22	20
IE3-W41R 315 M4	FF 600	508	126	590	550	416	460	457	120	150	554	216	320	80	70	M20	170	140	22	20
IE3-W41R 315 MX4	FF 600	508	110	590	610	494	498	457	120	150	554	216	495	80	70	M20	170	140	22	20
IE3-W41R 315 MY4	FF 600	508	110	590	610	494	498	457	120	-	573	216	495	80	70	M20	170	140	22	20
IE3-W41R 315 L4	FF 600	508	110	590	610	494	498	508	120	-	624	216	564	80	70	M20	170	140	22	20
IE3-W41R 315 LX4	FF 600	508	110	590	610	494	498	508	120	-	624	216	684	80	70	M20	170	140	22	20
IE3-W41R 315 S6	FF 600	508	126	590	550	416	460	406	120	150	554	216	371	80	70	M20	170	140	22	20
IE3-W41R 315 M6	FF 600	508	110	590	610	494	498	457	120	-	573	216	495	80	70	M20	170	140	22	20
IE3-W41R 315 MX6	FF 600	508	110	590	610	494	498	457	120	-	573	216	495	80	70	M20	170	140	22	20
IE3-W41R 315 L6	FF 600	508	110	590	610	494	498	508	120	-	624	216	564	80	70	M20	170	140	22	20
IE3-W41R 315 S8	FF 600	508	126	590	550	416	460	406	120	150	554	216	371	80	70	M20	170	140	22	20
IE3-W41R 315 M8	FF 600	508	110	590	610	494	498	457	120	150	573	216	495	80	70	M20	170	140	22	20
IE3-W41R 315 MX8	FF 600	508	110	590	610	494	498	457	120	-	624	216	564	80	70	M20	170	140	22	20
IE3-W41R 315 L8	FF 600	508	110	590	610	494	498	508	120	-	624	216	564	80	70	M20	170	140	22	20

¹⁾ Centre holes to DIN 332-DS

Energy-saving motor for Premium Efficiency IE3 Three-phase motors with squirrel-cage rotor

with surface cooling, type of cooling IC 411, degree of protection IP 55
Size 315

Type of construction IM B35 [IM 2001]

Flange dimensions, see page 2/109

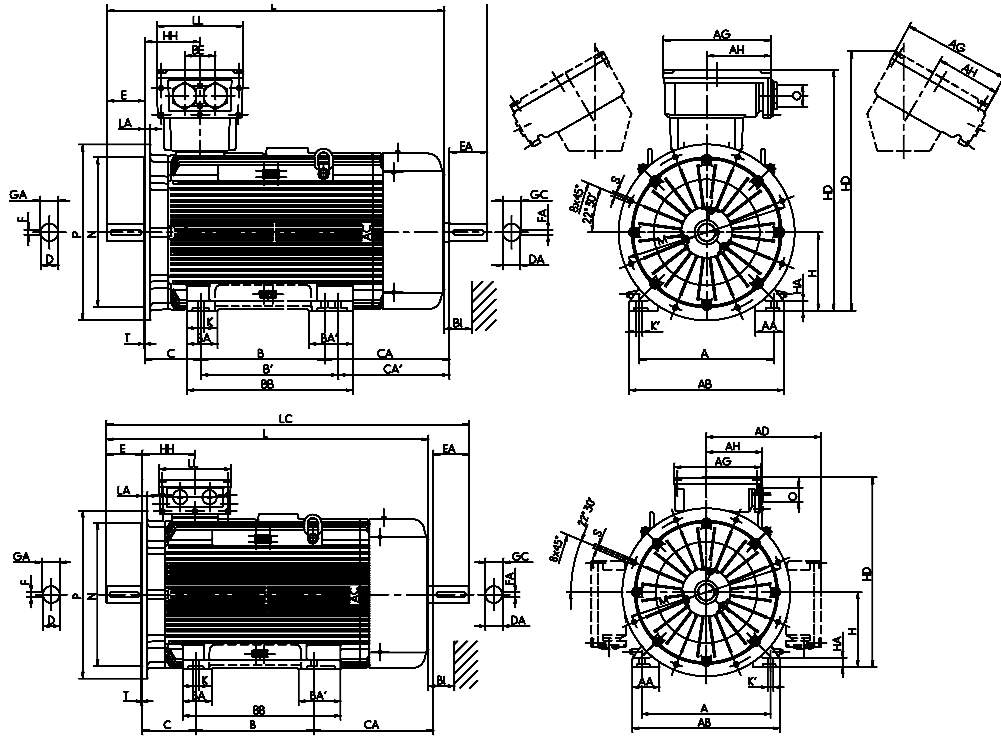

2

Type designation	GA	GC	H	HA	HD	HD ^{*)}	HD	HH	K	K'	L	LC	TB Type	AG	LL	AH	TB Type	AG	LL	AH	O	BI
	t	t1	h	c	p	p	VIK	A	s	s'	k	k1		x	z	-	VIK	x	z	-	r	BI
IE3-W41R 315 S2	69	69	315	44	731	610	775	211	28	35	1050	1218	200 A	282	242	-	400 A-SB	415	340	265	M63 x 1.5	55
IE3-W41R 315 M2	69	69	315	44	731	610	775	211	28	35	1105	1273	200 A	282	242	-	400 A-SB	415	340	265	M63 x 1.5	55
IE3-W41R 315 MX2	69	69	315	44	809	628	996	230	28	35	1200	1378	400 A-SB	415	340	265	630 A	496	390	301	M63 x 1.5	55
IE3-W41R 315 MY2	69	69	315	44	809	628	996	230	28	35	1270	1448	400 A-SB	415	340	265	630 A	496	390	301	M63 x 1.5	55
IE3-W41R 315 L2	69	69	315	44	809	628	996	230	28	35	1390	1568	400 A-SB	415	340	265	630 A	496	390	301	M63 x 1.5	55
IE3-W41R 315 LX2	69	69	315	44	809	628	996	230	28	35	1510	1688	400 A-SB	415	340	265	630 A	496	390	301	M63 x 1.5	55
IE3-W41R 315 S4	85	74.5	315	44	731	610	775	211	28	35	1080	1248	200 A	282	242	-	400 A-SB	415	340	265	M63 x 1.5	55
IE3-W41R 315 M4	85	74.5	315	44	731	610	775	211	28	35	1135	1303	200 A	282	242	-	400 A-SB	415	340	265	M63 x 1.5	55
IE3-W41R 315 MX4	85	74.5	315	44	809	628	996	230	28	35	1230	1408	400 A-SB	415	340	265	630 A	496	390	301	M63 x 1.5	55
IE3-W41R 315 MY4	85	74.5	315	44	809	628	996	230	28	35	1300	1478	400 A-SB	415	340	265	630 A	496	390	301	M63 x 1.5	55
IE3-W41R 315 L4	85	74.5	315	44	809	628	996	230	28	35	1420	1598	400 A-SB	415	340	265	630 A	496	390	301	M63 x 1.5	55
IE3-W41R 315 LX4	85	74.5	315	44	809	628	996	230	28	35	1540	1718	400 A-SB	415	340	265	630 A	496	390	301	M63 x 1.5	55
IE3-W41R 315 S6	85	74.5	315	44	731	595	775	211	28	35	1135	1303	200 A	282	242	-	400 A-SB	415	340	265	M63 x 1.5	55
IE3-W41R 315 M6	85	74.5	315	44	809	628	996	230	28	35	1300	1478	400 A-SB	415	340	265	630 A	496	390	301	M63 x 1.5	55
IE3-W41R 315 MX6	85	74.5	315	44	809	628	996	230	28	35	1300	1478	400 A-SB	415	340	265	630 A	496	390	301	M63 x 1.5	55
IE3-W41R 315 L6	85	74.5	315	44	809	628	996	230	28	35	1420	1598	400 A-SB	415	340	265	630 A	496	390	301	M63 x 1.5	55
IE3-W41R 315 S8	85	74.5	315	44	731	610	775	211	28	35	1135	1303	200 A	282	242	-	400 A-SB	415	340	265	M63 x 1.5	55
IE3-W41R 315 M8	85	74.5	315	44	809	628	996	230	28	35	1300	1478	400 A-SB	415	340	265	630 A	496	390	301	M63 x 1.5	55
IE3-W41R 315 MX8	85	74.5	315	44	809	628	996	230	28	35	1420	1598	400 A-SB	415	340	265	630 A	496	390	301	M63 x 1.5	55
IE3-W41R 315 L8	85	74.5	315	44	809	628	996	230	28	35	1420	1598	400 A-SB	415	340	265	630 A	496	390	301	M63 x 1.5	55

*) Terminal box left/right

**Energy-saving motor for Premium Efficiency IE3
Three-phase motors with squirrel-cage rotor**

with surface cooling, type of cooling IC 411, degree of protection IP 55
Size 56 to 160

Type of construction IM B14 [IM 3601]

Flange dimensions, see page 2/109

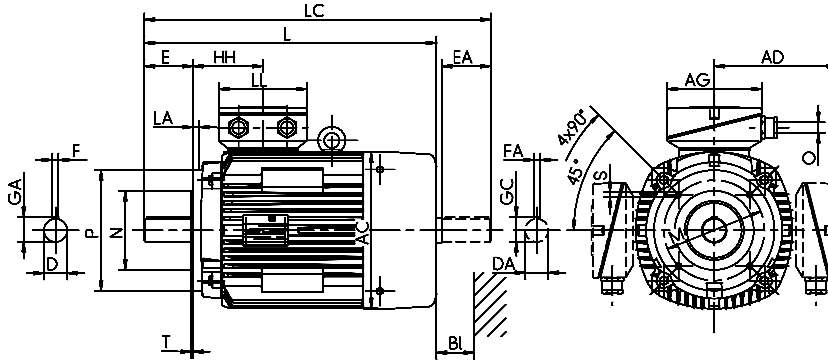

Type designation	Flange size		A	AA	AB	AC	AD	AD	B	BA	BB	C	CA	D	DA	DB ¹⁾	E	EA	F	FA
	small	large	b	n	f	g	g1	g1	a	m	e	w1	w2	d	d1		i	l1	u	u1
			VIK																	
IE3-W41R 56 G2	FT 65	FT 85	90	18	110	109	98	117	71	-	86	36	52	9	-	M3	20	-	3	3
IE3-W42R 63 K2, 4	FT 75	FT 100	100	28	128	109	98	118	80	-	100	40	39	11	11	M4	23	23	4	4
IE3-W41R 63 G2, 4, 6	FT 75	FT 100	100	21	120	124	104	124	80	-	95	40	59	11	11	M4	23	23	4	4
IE3-W42R 71 K2, 4/KY6	FT 85	FT 115	112	32	138	124	104	124	90	-	116	45	43.5	14	14	M5	30	30	5	5
IE3-W41R 71 G8/GY2, 4, 6	FT 85	FT 115	112	24	135	139	111	131	90	-	114	45	78	14	14	M5	30	30	5	5
IE3-W42R 80 K2, 8	FT 100	FT 130	125	38	168	139	111	131	100	-	125	50	63	19	19	M6	40	40	6	6
IE3-W41R 80 K2, 4, 6/GY2/G8	FT 100	FT 130	125	26	152	157	120	140	100	-	125	50	80	19	19	M6	40	40	6	6
IE3-W41R 80 G2, 4, 6/GX4	FT 100	FT 130	125	26	152	157	120	140	100	-	146	50	102	19	19	M6	40	40	6	6
IE3-W42R 90 S2/SY8	FT 115	FT 130	140	40	178	157	120	140	100	-	130	56	96	24	24	M8	50	50	8	6
IE3-W41R 90 S2, 8/SY4, 6	FT 115	FT 130	140	40	178	177	127	147	100	-	130	56	120	24	24	M8	50	50	8	6
IE3-W41R 90 S4, 6	FT 115	FT 130	140	40	178	177	127	147	100	-	130	56	125	24	24	M8	50	50	8	6
IE3-W41R 90 LY2	FT 115	FT 130	140	40	178	177	127	147	125	-	155	56	95	24	24	M8	50	50	8	6
IE3-W41R 90 LX4	FT 115	FT 130	140	40	178	177	127	147	125	-	155	56	150	24	24	M8	50	50	8	6
IE3-W41R 90 L2, 4, 6, 8	FT 115	FT 130	140	40	178	177	127	147	125	-	155	56	125	24	24	M8	50	50	8	6
IE3-W41R 100 LY8	FT 130	FT 165	160	32	188	196	137	157	140	-	171	63	102	28	28	M10	60	50	8	8
IE3-W41R 100 LY2/L8	FT 130	FT 165	160	42	193	196	137	156	140	-	175	63	102	28	28	M10	60	60	8	8
IE3-W41R 100 L2/LY4/LX6/LW8	FT 130	FT 165	160	42	193	196	137	156	140	-	175	63	136	28	28	M10	60	60	8	8
IE3-W41R 100 L4/LX4	FT 130	FT 165	160	42	193	196	137	156	140	-	175	63	166	28	28	M10	60	60	8	8
IE3-W41R 100 LX8	FT 130	FT 165	160	42	193	196	137	156	140	-	175	63	136	28	28	M10	60	60	8	8
IE3-W41R 100 LZ4, LW4	FT 130	FT 165	160	42	193	196	137	156	140	-	175	63	206	28	28	M10	60	60	8	8
IE3-W41R 112 M2, 8/MV6	FT 130	FT 165	190	52	225	196	136	156	140	-	180	70	159	28	28	M10	60	60	8	8
IE3-W41R 112 MY2	FT 130	FT 165	190	52	225	196	136	156	140	-	180	70	129	28	28	M10	60	60	8	8
IE3-W41R 112 MZ6, 8	FT 130	FT 165	190	52	225	196	137	156	140	-	180	70	199	28	28	M10	60	60	8	8
IE3-W40R 112 M2, W41R 112 MW4	FT 130	FT 165	190	45	226	217	178	189	140	42	172	70	192	28	28	M10	60	60	8	8
IE3-W41R 112 M4	FT 130	FT 165	190	45	226	217	178	189	140	42	172	70	242	28	28	M10	60	60	8	8
IE3-W41R 132 S2T	FT 165	FT 215	216	50	256	196	155	155	140	-	180	89	129	38	28	M12	80	60	10	8
IE3-W41R 132 S2, W42R 132 S8	FT 165	FT 215	216	50	256	217	178	189	140	55	180	89	173	38	32	M12	80	80	10	10
IE3-W41R 132 S6	FT 165	FT 215	216	50	256	217	178	189	140	55	180	89	223	38	32	M12	80	80	10	10
IE3-W41R 132 SX2	FT 165	FT 215	216	50	256	258	199	210	140	47	180	89	176	38	32	M12	80	80	10	10
IE3-W41R 132 S4	FT 165	FT 215	216	50	256	258	199	210	140	47	180	89	186	38	32	M12	80	80	10	10
IE3-W41R 132 M4	FT 165	FT 215	216	50	256	258	199	210	178	47	218	89	236	38	38	M12	80	80	10	10
IE3-W41R 132 M6	FT 165	FT 215	216	50	256	258	199	210	178	55	218	89	138	38	32	M12	80	80	10	10
IE3-W41R 132 MX6	FT 165	FT 215	216	50	256	258	199	210	178	47	218	89	236	38	38	M12	80	80	10	10
IE3-W41R 132 S8	FT 130	FT 165	216	50	256	258	199	210	140	55	180	89	223	38	32	M12	80	80	10	10
IE3-W41R 132 M8	FT 165	FT 215	216	50	256	258	199	210	178	55	218	89	138	38	32	M12	80	80	10	10
IE3-W41R 160 M2	FT 215	C300	254	55	296	313	242	275	210	60	257	108	148	42	42	M16	110	110	12	12
IE3-W41R 160 MX2	FT 215	C300	254	55	296	313	242	275	210	56	257	108	186	42	42	M16	110	110	12	12
IE3-W41R 160 L2	FT 215	C300	254	55	296	313	242	275	254	60	301	108	192	42	42	M16	110	110	12	12
IE3-W41R 160 M4	FT 215	C300	254	55	296	313	242	275	210	60	257	108	148	42	42	M16	110	110	12	12
IE3-W41R 160 L4C	FT 215	C300	254	55	296	313	242	275	254	60	301	108	192	42	42	M16	110	110	12	12
IE3-W41R 160 M6	FT 215	C300	254	55	296	313	242	275	210	56	257	108	186	42	42	M16	110	110	12	12
IE3-W41R 160 L6C	FT 215	C300	254	55	296	313	242	275	254	60	301	108	192	42	42	M16	110	110	12	12
IE3-W41R 160 M8	FT 215	C300	254	55	296	313	242	275	210	60	257	108	185	42	42	M16	110	110	12	12
IE3-W41R 160 MX8	FT 215	C300	254	55	296	313	242	275	210	56	257	108	186	42	42	M16	110	110	12	12
IE3-W41R 160 L8	FT 215	C300	254	55	296	313	242	275	254	60	301	108	192	42	42	M16	110	110	12	12

Low voltage electrical machines

¹⁾ Centre holes to DIN 332-DS

Energy-saving motor for Premium Efficiency IE3 Three-phase motors with squirrel-cage rotor

with surface cooling, type of cooling IC 411, degree of protection IP 55
Size 56 to 160

Type of construction IM B34 [IM 2101]

Flange dimensions, see page 2/109

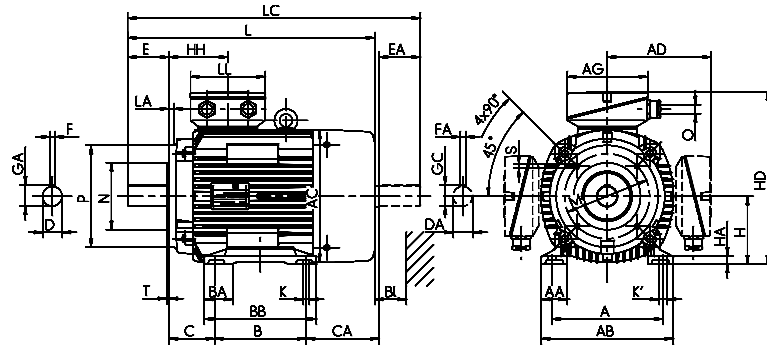

Type designation	GA	GC	H	HA	HD	HD ⁽¹⁾	HD	HH	K	K'	L	LC	TB Type	AG	LL	TB Type	AG	LL	O	Hole pattern	Bl.
	t	t1	h	c	p	p	VIK	A	s	s'	k	k1		x	z	VIK	x	z	-		Bl
IE3-W41R 56 G2	10	10.2	56	7	154	***	174	58	6	6	176	199	KA 05	92	92	KA 05-13	104	112	M20 x 1.5	4L	14
IE3-W42R 63 K2, 4	13	12.5	63	10	161	***	181	58	8	8	179	205	KA 05	92	92	KA 05-13	104	112	M20 x 1.5	4L	14
IE3-W41R 63 G2, 4, 6	13	12.5	63	7.5	167	***	187	61	7	7	199	225	KA 05	92	92	KA 05-13	104	112	M20 x 1.5	4L	14
IE3-W42R 71 K2, 4/KY6	16	16	71	11	175	***	195	61	8	8	206	239	KA 05	92	92	KA 05-13	104	112	M20 x 1.5	4L	14
IE3-W41R 71 G8/GY2, 4, 6	16	16	71	8	182	***	202	67	7	7	238	273	KA 05	92	92	KA 05-13	104	112	M20 x 1.5	4L	14
IE3-W42R 80 K2, 8	22	21.5	80	12	191	***	211	67	10	10	249	293	KA 05	92	92	KA 05-13	104	112	M20 x 1.5	4L	16
IE3-W41R 80 K2, 4, 6/GY2/G8	22	21.5	80	9	200	***	220	70	10	10	265	310	KA 05	92	92	KA 05-13	104	112	M20 x 1.5	4L	16
IE3-W41R 80 G2, 4, 6/GX4	22	21.5	80	9	200	***	220	70	10	10	287	332	KA 05	92	92	KA 05-13	104	112	M20 x 1.5	4L	16
IE3-W42R 90 S2/SY8	27	24.5	90	14	210	***	230	70	10	10	297	352	KA 05	92	92	KA 05-13	104	112	M25 x 1.5	4L	16
IE3-W41R 90 S2, 8/SY4, 6	27	24.5	90	10.5	217	***	237	75	10	10	321	376	KA 05	92	92	KA 05-13	104	112	M25 x 1.5	4L	18
IE3-W41R 90 S4, 6	27	24.5	90	10.5	217	***	237	75	10	10	351	406	KA 05	92	92	KA 05-13	104	112	M25 x 1.5	4L	18
IE3-W41R 90 LY2	27	24.5	90	11	217	***	237	75	10	10	321	376	KA 05	92	92	KA 05-13	104	112	M25 x 1.5	4L	18
IE3-W41R 90 LX4	27	24.5	90	10.5	217	***	237	75	10	10	376	431	KA 05	92	92	KA 05-13	104	112	M25 x 1.5	4L	18
IE3-W41R 90 L2, 4, 6, 8	27	24.5	90	10.5	217	***	237	75	10	10	351	406	KA 05	92	92	KA 05-13	104	112	M25 x 1.5	4L	18
IE3-W41R 100 LY8	31	31	100	11	237	***	257	77	12	12	357	425	KA 05	92	92	KA 05-13	104	112	M25 x 1.5	4L	20
IE3-W41R 100 LY2/L8	31	31	100	13	236	***	256	77	12	12	357	425	KA 05	92	92	KA 05-13	104	112	M25 x 1.5	4L	20
IE3-W41R 100 L2/LY4/LX6/LW8	31	31	100	13	236	***	256	77	12	12	391	459	KA 05	92	92	KA 05-13	104	112	M25 x 1.5	4L	20
IE3-W41R 100 L4/LX4	31	31	100	13	236	***	256	77	12	12	421	489	KA 05	92	92	KA 05-13	104	112	M25 x 1.5	4L	20
IE3-W41R 100 LX8	31	31	100	13	236	***	256	77	12	12	391	459	KA 05	92	92	KA 05-13	104	112	M25 x 1.5	4L	20
IE3-W41R 100 LZ4, LW4	31	31	100	18	236	***	256	77	12	12	461	529	KA 05	92	92	KA 05-13	104	112	M25 x 1.5	4L	20
IE3-W41R 112 M2, 8/MV6	31	31	112	18	248	***	268	77	12	12	421	489	KA 05	92	92	KA 05-13	104	112	M25 x 1.5	4L	20
IE3-W41R 112 MY2	31	31	112	18	248	***	268	77	12	12	391	459	KA 05	92	92	KA 05-13	104	112	M25 x 1.5	4L	20
IE3-W41R 112 MZ6, 8	31	31	112	18	248	***	268	77	12	12	461	529	KA 05	92	92	KA 05-13	104	112	M25 x 1.5	4L	20
IE3-W40R 112 M2, W41R 112 MW4	31	31	112	15	290	236.5	297	108	12	12	459	522	25 A	156	145	25 AV	156	145	M32 x 1.5	4L	35
IE3-W41R 112 M4	31	31	112	15	290	236.5	297	108	12	12	509	572	25 A	156	145	25 AV	156	145	M32 x 1.5	4L	35
IE3-W41R 132 S2T	41	31	132	18	287	***	287	105	12	12	460	528	KA 05-13	104	112	KA 05-13	104	112	M25 x 1.5	4L	20
IE3-W41R 132 S2, W42R 132 S8	41	35	132	16	310	256.5	317	108	12	12	479	562	25 A	156	145	25 AV	156	145	M32 x 1.5	4L	35
IE3-W41R 132 S6	41	35	132	16	310	256.5	317	108	12	12	529	612	25 A	156	145	25 AV	156	145	M32 x 1.5	4L	35
IE3-W41R 132 SX2	41	41	132	15	331	279	338	114	12	12	481	565	25 A	156	145	25 AV	156	145	M32 x 1.5	4L	35
IE3-W41R 132 S4	41	41	132	15	331	279	338	114	12	12	529	613	25 A	156	145	25 AV	156	145	M32 x 1.5	4L	35
IE3-W41R 132 M4	41	41	132	15	331	279	338	114	12	12	579	663	25 A	156	145	25 AV	156	145	M32 x 1.5	4L	35
IE3-W41R 132 M6	41	35	132	16	331	279	338	114	12	12	481	565	25 A	156	145	25 AV	156	145	M32 x 1.5	4L	35
IE3-W41R 132 MX6	41	41	132	15	331	279	338	114	12	12	579	663	25 A	156	145	25 AV	156	145	M32 x 1.5	4L	35
IE3-W41R 132 S8	41	35	132	16	331	279	338	114	12	12	481	565	25 A	156	145	25 AV	156	145	M32 x 1.5	4L	35
IE3-W41R 132 M8	41	35	132	16	331	279	338	114	12	12	481	565	25 A	156	145	25 AV	156	145	M32 x 1.5	4L	35
IE3-W41R 160 M2	45	45	160	18	402	336	435	138	15	20	571	686	63 A	193	167	100/63 AV	223	214	M40 x 1.5	4L	35
IE3-W41R 160 MX2	45	45	160	18	402	336	435	138	15	20	609	724	63 A	193	167	100/63 AV	223	214	M40 x 1.5	4L	35
IE3-W41R 160 L2	45	45	160	18	402	336	435	138	15	20	659	774	63 A	193	167	100/63 AV	223	214	M40 x 1.5	4L	35
IE3-W41R 160 M4	45	45	160	18	402	336	435	138	15	20	571	686	63 A	193	167	100/63 AV	223	214	M40 x 1.5	4L	35
IE3-W41R 160 L4C	45	45	160	18	402	336	435	138	15	20	659	774	63 A	193	167	100/63 AV	223	214	M40 x 1.5	4L	35
IE3-W41R 160 M6	45	45	160	18	402	336	435	138	15	20	609	724	63 A	193	167	100/63 AV	223	214	M40 x 1.5	4L	35
IE3-W41R 160 L6C	45	45	160	18	402	336	435	138	15	20	659	774	63 A	193	167	100/63 AV	223	214	M40 x 1.5	4L	35
IE3-W41R 160 M8	45	45	160	18	402	336	435	138	15	20	571	693	63 A	193	167	100/63 AV	223	214	M40 x 1.5	4L	35
IE3-W41R 160 MX8	45	45	160	18	402	336	435	138	15	20	571	724	63 A	193	167	100/63 AV	223	214	M40 x 1.5	4L	35
IE3-W41R 160 L8	45	45	160	18	402	336	435	138	15	20	659	774	63 A	193	167	100/63 AV	223	214	M40 x 1.5	4L	35

⁽¹⁾ Terminal box left/right

*** upon request

**Energy-saving motor for Premium Efficiency IE3
Three-phase motors with squirrel-cage rotor**

with surface cooling, type of cooling IC 411, degree of protection IP 55
Size 56 to 132

Type of construction IM B5 [IM 3001]

Type of construction IM V1 [IM 3011]

Flange dimensions, see page 2/109

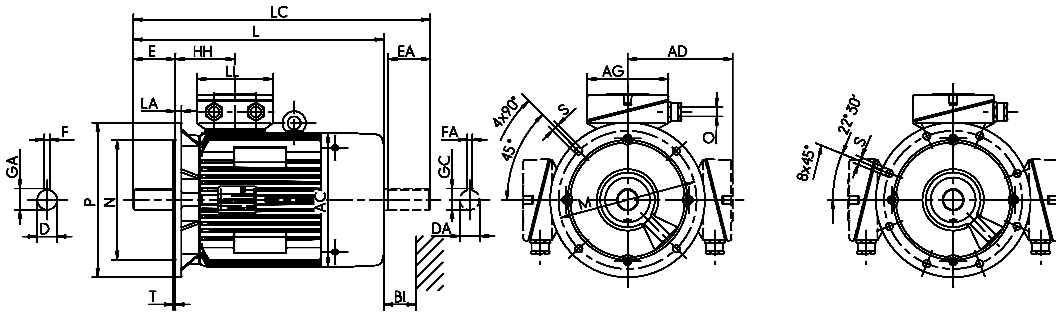

Type designation	Flange size	AC	AD	AD	D	DA	DB ¹⁾	E	EA	F	FA	GA	GC	H	HH
		g	g1	g1	d	d1		l	l1	u	u1	t	t1	h	A
IE3-W41R 56 G2	FF 100	109	98	117	9	-	M3	20	-	3	3	10	10.2	56	81
IE3-W42R 63 K2, 4	FF 115	109	98	118	11	11	M4	23	23	4	4	13	12.5	63	58
IE3-W41R 63 G2, 4, 6	FF 115	124	104	124	11	11	M4	23	23	4	4	13	12.5	63	94
IE3-W42R 71 K2, 4, KY6	FF 130	124	104	124	14	14	M5	30	30	5	5	16	16	71	61
IE3-W41R 71 G8/GY2, 4, 6	FF 130	139	111	131	14	14	M5	30	30	5	5	16	16	71	97
IE3-W42R 80 K2, 8	FF 165	139	111	131	19	19	M6	40	40	6	6	22	21.5	80	67
IE3-W41R 80 K2, 4, 6/GY2/G8	FF 165	157	120	140	19	19	M6	40	40	6	6	22	21.5	80	70
IE3-W41R 80 G2, 4, 6/GX4	FF 165	157	120	140	19	19	M6	40	40	6	6	22	21.5	80	70
IE3-W42R 90 S2/SY8	FF 165	157	120	140	24	24	M8	50	50	8	6	27	24.5	90	70
IE3-W41R 90 S2, 8/SY4, 6	FF 165	177	127	147	24	24	M8	50	50	8	6	27	24.5	90	114
IE3-W41R 90 S4, 6	FF 165	177	127	147	24	24	M8	50	50	8	6	27	24.5	90	114
IE3-W41R 90 LY2	FF 165	177	127	147	24	24	M8	50	50	8	6	27	24.5	90	114
IE3-W41R 90 LX4	FF 165	177	127	147	24	24	M8	50	50	8	6	27	24.5	90	114
IE3-W41R 90 L2, 4, 6, 8	FF 165	177	127	147	24	24	M8	50	50	8	6	27	24.5	90	114
IE3-W41R 100 LY8	FF 215	196	137	157	28	28	M10	60	60	8	8	31	31	100	77
IE3-W41R 100 LY2/L8	FF 215	196	137	156	28	28	M10	60	60	8	8	31	31	100	77
IE3-W41R 100 L2/LY4/LX6/LW8	FF 215	196	137	156	28	28	M10	60	60	8	8	31	31	100	77
IE3-W41R 100 L4/LX4	FF 215	196	137	156	28	28	M10	60	60	8	8	31	31	100	77
IE3-W41R 100 LX8	FF 215	196	137	156	28	28	M10	60	60	8	8	31	31	100	77
IE3-W41R 100 LZ4, LW4	FF 215	196	137	156	28	28	M10	60	60	8	8	31	31	100	77
IE3-W41R 112 M2, 8/MV6	FF 215	196	136	156	28	28	M10	60	60	8	8	31	31	112	77
IE3-W41R 112 MY2	FF 215	196	136	156	28	28	M10	60	60	8	8	31	31	112	77
IE3-W41R 112 MZ6, 8	FF 215	196	137	156	28	28	M10	60	60	8	8	31	31	112	77
IE3-W40R 112 M2, W41R 112 MW4	FF 215	217	178	189	28	28	M10	60	60	8	8	31	31	112	107
IE3-W41R 112 M4	FF 215	217	178	189	28	28	M10	60	60	8	8	31	31	112	107
IE3-W41R 132 S2T	FF 265	196	155	155	38	28	M12	80	60	10	8	41	31	132	105
IE3-W41R 132 S2, W42R 132 S8	FF 265	217	178	189	38	32	M12	80	80	10	10	41	35	132	107
IE3-W41R 132 S6	FF 265	217	178	189	38	32	M12	80	80	10	10	41	35	132	107
IE3-W41R 132 SX2	FF 265	258	199	210	38	32	M12	80	80	10	10	41	35	132	114
IE3-W41R 132 S4	FF 265	258	199	210	38	32	M12	80	80	10	10	41	35	132	114
IE3-W41R 132 M4	FF 265	258	199	210	38	38	M12	80	80	10	10	41	41	132	114
IE3-W41R 132 M6	FF 265	258	199	210	38	32	M12	80	80	10	10	41	35	132	114
IE3-W41R 132 MX6	FF 265	258	199	210	38	38	M12	80	80	10	10	41	41	132	114
IE3-W41R 132 S8	FF 265	258	199	210	38	32	M12	80	80	10	10	41	35	132	114
IE3-W41R 132 M8	FF 265	258	199	210	38	32	M12	80	80	10	10	41	35	132	114

¹⁾ Centre holes to DIN 332-DS

Type designation	L	LC	TB Type	AG	LL	TB Type	AG	LL	O	Hole pattern	Bl.
	k	k1		x	z	VIK	x	z	-		Bl
IE3-W41R 56 G2	199	223	KA 05	92	92	KA 05-13	104	112	M20 x 1.5	4L	14
IE3-W42R 63 K2, 4	179	205	KA 05	92	92	KA 05-13	104	112	M20 x 1.5	4L	14
IE3-W41R 63 G2, 4, 6	232	258	KA 05	92	92	KA 05-13	104	112	M20 x 1.5	4L	14
IE3-W42R 71 K2, 4/KY6	206	239	KA 05	92	92	KA 05-13	104	112	M20 x 1.5	4L	14
IE3-W41R 71 G8/GY2 ,4, 6	269	303	KA 05	92	92	KA 05-13	104	112	M20 x 1.5	4L	14
IE3-W42R 80 K2, 8	249	293	KA 05	92	92	KA 05-13	104	112	M20 x 1.5	4L	16
IE3-W41R 80 K2, 4, 6/GY2/G8	265	310	KA 05	92	92	KA 05-13	104	112	M20 x 1.5	4L	16
IE3-W41R 80 G2, 4, 6/GX4	287	332	KA 05	92	92	KA 05-13	104	112	M20 x 1.5	4L	16
IE3-W42R 90 S2/SY8	297	352	KA 05	92	92	KA 05-13	104	112	M25 x 1.5	4L	16
IE3-W41R 90 S2, 8/SY4, 6	360	415	KA 05	92	92	KA 05-13	104	112	M25 x 1.5	4L	18
IE3-W41R 90 S4, 6	390	445	KA 05	92	92	KA 05-13	104	112	M25 x 1.5	4L	18
IE3-W41R 90 LY2	360	415	KA 05	92	92	KA 05-13	104	112	M25 x 1.5	4L	18
IE3-W41R 90 LX4	416	471	KA 05	92	92	KA 05-13	104	112	M25 x 1.5	4L	18
IE3-W41R 90 L2, 4, 6, 8	390	445	KA 05	92	92	KA 05-13	104	112	M25 x 1.5	4L	18
IE3-W41R 100 LY8	357	425	KA 05	92	92	KA 05-13	104	112	M25 x 1.5	4L	20
IE3-W41R 100 LY2/L8	357	425	KA 05	92	92	KA 05-13	104	112	M25 x 1.5	4L	20
IE3-W41R 100 L2/LY4/LX6/LW8	391	459	KA 05	92	92	KA 05-13	104	112	M25 x 1.5	4L	20
IE3-W41R 100 L4/LX4	421	489	KA 05	92	92	KA 05-13	104	112	M25 x 1.5	4L	20
IE3-W41R 100 LX8	391	459	KA 05	92	92	KA 05-13	104	112	M25 x 1.5	4L	20
IE3-W41R 100 LZ4, LW4	461	529	KA 05	92	92	KA 05-13	104	112	M25 x 1.5	4L	20
IE3-W41R 112 M2, 8/MV6	421	489	KA 05	92	92	KA 05-13	104	112	M25 x 1.5	4L	20
IE3-W41R 112 MY2	391	459	KA 05	92	92	KA 05-13	104	112	M25 x 1.5	4L	20
IE3-W41R 112 MZ6, 8	461	529	KA 05	92	92	KA 05-13	104	112	M25 x 1.5	4L	20
IE3-W40R 112 M2, W41R 112 MW4	457	522	25 A	156	145	25 AV	156	145	M32 x 1.5	4L	35
IE3-W41R 112 M4	507	572	25 A	156	145	25 AV	156	145	M32 x 1.5	4L	35
IE3-W41R 132 S2T	460	528	KA 05-13	104	112	KA 05-13	104	112	M32 x 1.5	4L	20
IE3-W41R 132 S2, W42R 132 S8	479	562	25 A	156	145	25 AV	156	145	M32 x 1.5	4L	35
IE3-W41R 132 S6	529	612	25 A	156	145	25 AV	156	145	M32 x 1.5	4L	35
IE3-W41R 132 SX2	481	565	25 A	156	145	25 AV	156	145	M32 x 1.5	4L	35
IE3-W41R 132 S4	529	613	25 A	156	145	25 AV	156	145	M32 x 1.5	4L	35
IE3-W41R 132 M4	579	663	25 A	156	145	25 AV	156	145	M32 x 1.5	4L	35
IE3-W41R 132 M6	481	565	25 A	156	145	25 AV	156	145	M32 x 1.5	4L	35
IE3-W41R 132 MX6	579	663	25 A	156	145	25 AV	156	145	M32 x 1.5	4L	35
IE3-W41R 132 S8	481	565	25 A	156	145	25 AV	156	145	M32 x 1.5	4L	35
IE3-W41R 132 M8	481	565	25 A	156	145	25 AV	156	145	M32 x 1.5	4L	35

**Energy-saving motor for Premium Efficiency IE3
Three-phase motors with squirrel-cage rotor**

with surface cooling, type of cooling IC 411, degree of protection IP 55
Size 160 to 280

Type of construction IM B5 [IM 3001]

Type of construction IM V1 [IM 3011]

Flange dimensions, see page 2/109

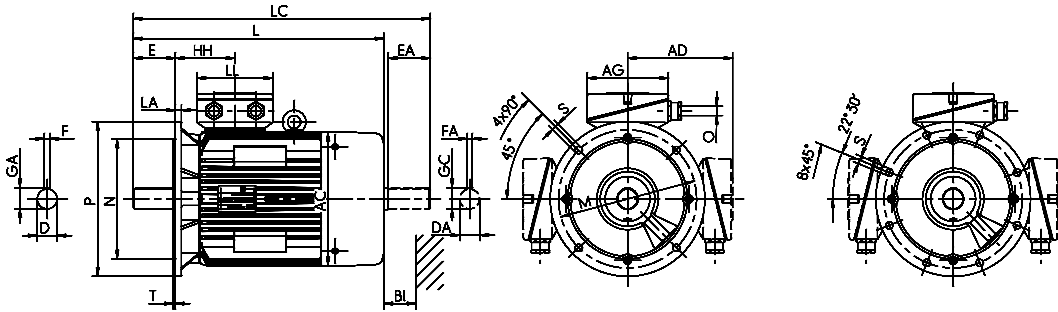

Type designation	Flange size	AC	AD	AD	D	DA	DB ¹⁾	E	EA	F	FA	GA	GC	H	HH
		g	g1	g1	d	d1		l	l1	u	u1	t	t1	h	A
		VIK													
IE3-W41R 160 M2	FF 300	313	242	275	42	42	M16	110	110	12	12	45	45	160	138
IE3-W41R 160 MX2	FF 300	313	242	275	42	42	M16	110	110	12	12	45	45	160	138
IE3-W41R 160 L2	FF 300	313	242	275	42	42	M16	110	110	12	12	45	45	160	138
IE3-W41R 160 M4	FF 300	313	242	275	42	42	M16	110	110	12	12	45	45	160	138
IE3-W41R 160 L4C	FF 300	313	242	275	42	42	M16	110	110	12	12	45	45	160	138
IE3-W41R 160 M6	FF 300	313	242	275	42	42	M16	110	110	12	12	45	45	160	138
IE3-W41R 160 L6C	FF 300	313	242	275	42	42	M16	110	110	12	12	45	45	160	138
IE3-W41R 160 M8	FF 300	313	242	275	42	42	M16	110	80	12	10	45	45	160	138
IE3-W41R 160 MX8	FF 300	313	242	275	42	42	M16	110	110	12	12	45	45	160	138
IE3-W41R 160 L8	FF 300	313	242	275	42	42	M16	110	110	12	12	45	45	160	138
IE3-W41R 180 M2C	FF 300	351	261	294	48	48	M16	110	110	14	14	51.5	51.5	180	147
IE3-W41R 180 M4	FF 300	351	261	294	48	48	M16	110	110	14	14	51.5	51.5	180	147
IE3-W41R 180 L4	FF 300	351	261	294	48	48	M16	110	110	14	14	51.5	51.5	180	147
IE3-W41R 180 L6C	FF 300	351	261	294	48	48	M16	110	110	14	14	51.5	51.5	180	147
IE3-W41R 180 L8	FF 300	351	261	294	48	48	M16	110	110	14	14	51.5	51.5	180	147
IE3-W41R 200 L2	FF 350	390	300	378	55	55	M20	110	110	16	16	59	59	200	168
IE3-W41R 200 LX2C	FF 350	390	300	378	55	55	M20	110	110	16	16	59	59	200	168
IE3-W41R 200 L4C	FF 350	390	300	378	55	55	M20	110	110	16	16	59	59	200	168
IE3-W41R 200 L6	FF 350	390	300	378	55	55	M20	110	110	16	16	59	59	200	168
IE3-W41R 200 LX6C	FF 350	390	300	378	55	55	M20	110	110	16	16	59	59	200	168
IE3-W41R 200 L8	FF 350	351	261	294	55	48	M20	110	110	16	14	59	51.5	200	147
IE3-W41R 225 M2	FF 400	440	324	406	55	55	M20	110	110	16	16	59	59	225	177
IE3-W41R 225 S4C	FF 400	390	300	378	60	55	M20	140	110	18	16	64	59	225	168
IE3-W41R 225 M4	FF 400	440	324	406	60	55	M20	140	110	18	16	64	59	225	177
IE3-W41R 225 M6	FF 400	440	324	406	60	55	M20	140	110	18	16	64	59	225	177
IE3-W41R 225 S8	FF 400	390	300	378	60	55	M20	140	110	18	16	64	59	225	168
IE3-W41R 225 M8	FF 400	440	324	406	60	55	M20	140	110	18	16	64	59	225	177
IE3-W41R 250 M2	FF 500	490	386	399	60	55	M20	140	110	18	18	64	59	250	206
IE3-W41R 250 M4	FF 500	490	386	399	65	55	M20	140	110	18	18	69	59	280	206
IE3-W41R 250 M6	FF 500	490	386	399	65	55	M20	140	110	18	16	69	59	250	206
IE3-W41R 250 M8	FF 500	440	386	406	65	55	M20	140	110	18	16	69	59	250	206
IE3-W41R 280 S2	FF 500	490	386	399	65	65	M20	140	140	18	18	69	69	280	206
IE3-W41R 280 M2	FF 500	490	386	399	65	65	M20	140	140	18	18	69	69	280	206
IE3-W41R 280 S4	FF 500	490	386	399	75	65	M20	140	140	20	18	79.5	69	280	206
IE3-W41R 280 M4	FF 500	550	416	460	75	65	M20	140	140	20	18	79.5	69	280	211
IE3-W41R 280 S6	FF 500	550	416	460	75	65	M20	140	110	20	18	79.5	69	280	211
IE3-W41R 280 M6	FF 500	550	416	460	75	65	M20	140	140	20	18	79.5	69	280	211
IE3-W41R 280 S8	FF 500	550	416	460	75	65	M20	140	110	20	18	79.5	69	280	211
IE3-W41R 280 M8	FF 500	550	416	460	75	65	M20	140	140	20	18	79.5	69	280	211

¹⁾ Centre holes to DIN 332-DS

Type designation	L	LC	TB Type	AG	LL	TB Type	AG	LL	O	Hole pattern	Bl.
	k	k1		x	z	VIK	x	z	-		Bl
IE3-W41R 160 M2	571	686	63 A	193	167	100/63 AV	223	214	M40 x 1.5	4L	35
IE3-W41R 160 MX2	609	724	63 A	193	167	100/63 AV	223	214	M40 x 1.5	4L	35
IE3-W41R 160 L2	659	774	63 A	193	167	100/63 AV	223	214	M40 x 1.5	4L	35
IE3-W41R 160 M4	571	686	63 A	193	167	100/63 AV	223	214	M40 x 1.5	4L	35
IE3-W41R 160 L4C	659	774	63 A	193	167	100/63 AV	223	214	M40 x 1.5	4L	35
IE3-W41R 160 M6	609	724	63 A	193	167	100/63 AV	223	214	M40 x 1.5	4L	35
IE3-W41R 160 L6C	659	774	63 A	193	167	100/63 AV	223	214	M40 x 1.5	4L	35
IE3-W41R 160 M8	571	724	63 A	193	167	100/63 AV	223	214	M40 x 1.5	4L	35
IE3-W41R 160 MX8	571	724	63 A	193	167	100/63 AV	223	214	M40 x 1.5	4L	35
IE3-W41R 160 L8	659	774	63 A	193	167	100/63 AV	223	214	M40 x 1.5	4L	35
IE3-W41R 180 M2C	680	796	63 A	193	167	100/63 AV	223	214	M40 x 1.5	4L	35
IE3-W41R 180 M4	680	796	63 A	193	167	100/63 AV	223	214	M40 x 1.5	4L	35
IE3-W41R 180 L4	730	846	63 A	193	167	100/63 AV	223	214	M40 x 1.5	4L	35
IE3-W41R 180 L6C	680	796	63 A	193	167	100/63 AV	223	214	M40 x 1.5	4L	35
IE3-W41R 180 L8	680	796	63 A	193	167	100/63 AV	223	214	M40 x 1.5	4L	35
IE3-W41R 200 L2	767	891	100 A	213	207	200 A-SB	335	270	M50 x 1.5	4L	40
IE3-W41R 200 LX2C	767	891	100 A	213	207	200 A-SB	335	270	M50 x 1.5	4L	40
IE3-W41R 200 L4C	767	891	100 A	213	207	200 A-SB	335	270	M50 x 1.5	4L	35
IE3-W41R 200 L6	767	891	100 A	213	207	200 A-SB	335	270	M50 x 1.5	4L	35
IE3-W41R 200 LX6C	767	891	100 A	213	207	200 A-SB	335	270	M50 x 1.5	4L	35
IE3-W41R 200 L8	730	846	63 A	193	167	100/63 AV	223	214	M50 x 1.5	4L	35
IE3-W41R 225 M2	832	947	100 A	213	207	200 A-SB	335	270	M50 x 1.5	8L	45
IE3-W41R 225 S4C	847	971	100 A	213	207	200 A-SB	335	270	M50 x 1.5	8L	40
IE3-W41R 225 M4	912	1027	100 A	213	207	200 A-SB	335	270	M50 x 1.5	8L	45
IE3-W41R 225 M6	912	1027	100 A	213	207	200 A-SB	335	270	M50 x 1.5	8L	45
IE3-W41R 225 S8	797	921	100 A	213	207	200 A-SB	335	270	M50 x 1.5	8L	40
IE3-W41R 225 M8	862	977	100 A	213	207	200 A-SB	335	270	M50 x 1.5	8L	45
IE3-W41R 250 M2	924	1072	200 A	282	242	200 A-SB	335	270	M50 x 1.5	8L	55
IE3-W41R 250 M4	924	1072	200 A	282	242	200 A-SB	335	270	M50 x 1.5	8L	50
IE3-W41R 250 M6	924	1042	200 A	282	242	200 A-SB	335	270	M50 x 1.5	8L	50
IE3-W41R 250 M8	924	1042	200 A	282	242	200 A-SB	335	270	M63 x 1.5	8L	50
IE3-W41R 280 S2	924	1072	200 A	282	242	200 A-SB	335	270	M63 x 1.5	8L	55
IE3-W41R 280 M2	970	1118	200 A	282	242	200 A-SB	335	270	M63 x 1.5	8L	55
IE3-W41R 280 S4	970	1118	200 A	282	242	200 A-SB	335	270	M63 x 1.5	8L	50
IE3-W41R 280 M4	1105	1273	200 A	282	242	200 A-SB	335	270	M63 x 1.5	8L	55
IE3-W41R 280 S6	1050	1218	200 A	282	242	200 A-SB	335	270	M63 x 1.5	8L	55
IE3-W41R 280 M6	1105	1273	200 A	282	242	200 A-SB	335	270	M63 x 1.5	8L	55
IE3-W41R 280 S8	1050	1218	200 A	282	242	200 A-SB	335	270	M63 x 1.5	8L	55
IE3-W41R 280 M8	1105	1273	200 A	282	242	200 A-SB	335	270	M63 x 1.5	8L	55

**Energy-saving motor for Premium Efficiency IE3
Three-phase motors with squirrel-cage rotor**

with surface cooling, type of cooling IC 411, degree of protection IP 55
Size 315

Type of construction IM B5 [IM 3001]

Type of construction IM V1 [IM 3011]

Flange dimensions, see page 2/109

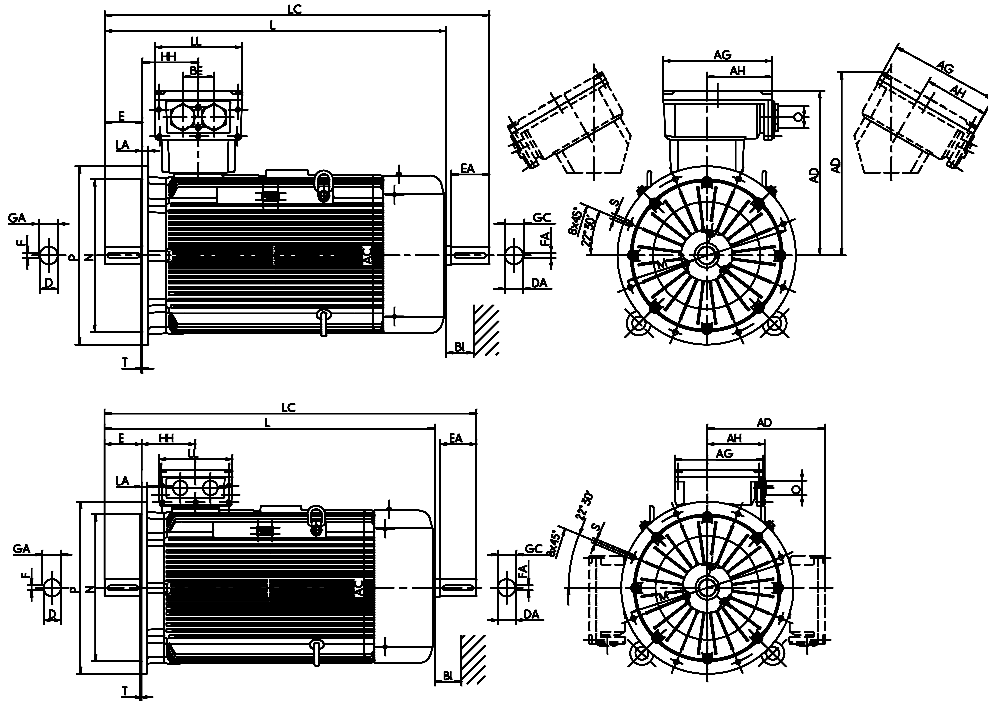

Type designation	Flange size	AC	AD	AD	D	DA	DB ¹⁾	E	EA	F	FA	GA	GC
		g	g1	g1	d	d1		l	l1	u	u1	t	t1
IE3-W41R 315 S2	FF 600	550	416	460	65	65	M20	140	140	18	18	69	69
IE3-W41R 315 M2	FF 600	550	416	460	65	65	M20	140	140	18	18	69	69
IE3-W41R 315 MX2	FF 600	610	494	498	65	65	M20	140	140	18	18	69	69
IE3-W41R 315 MY2	FF 600	610	494	498	65	65	M20	140	140	18	18	69	69
IE3-W41R 315 L2	FF 600	610	494	498	65	65	M20	140	140	18	18	69	69
IE3-W41R 315 LX2	FF 600	610	494	498	65	65	M20	140	140	18	18	69	69
IE3-W41R 315 S4	FF 600	550	416	460	80	70	M20	170	140	22	20	85	75
IE3-W41R 315 M4	FF 600	550	416	460	80	70	M20	170	140	22	20	85	75
IE3-W41R 315 MX4	FF 600	610	494	498	80	70	M20	170	140	22	20	85	75
IE3-W41R 315 MY4	FF 600	610	494	498	80	70	M20	170	140	22	20	85	75
IE3-W41R 315 L4	FF 600	610	494	498	80	70	M20	170	140	22	20	85	75
IE3-W41R 315 LX4	FF 600	610	494	498	80	70	M20	170	140	22	20	85	75
IE3-W41R 315 S6	FF 600	550	416	460	80	70	M20	170	140	22	20	85	75
IE3-W41R 315 M6	FF 600	610	494	498	80	70	M20	170	140	22	20	85	75
IE3-W41R 315 MX6	FF 600	610	494	498	80	70	M20	170	140	22	20	85	75
IE3-W41R 315 L6	FF 600	610	494	498	80	70	M20	170	140	22	20	85	75
IE3-W41R 315 S8	FF 600	550	416	460	80	70	M20	170	140	22	20	85	75
IE3-W41R 315 M8	FF 600	610	494	498	80	70	M20	170	140	22	20	85	75
IE3-W41R 315 MX8	FF 600	610	494	498	80	70	M20	170	140	22	20	85	75
IE3-W41R 315 L8	FF 600	610	494	498	80	70	M20	170	140	22	20	85	75

¹⁾ Centre holes to DIN 332-D

Type designation	H	HH	L	LC	TB Type	AG	LL	AH	TB Type	AG	LL	AH	O	BI.
	h	A	k	k1		x	z	-	VIK	x	z	-	r	BI
IE3-W41R 315 S2	315	211	1050	1218	200 A	282	242	-	400 A-SB	415	340	265	M63 x 1.5	55
IE3-W41R 315 M2	315	211	1105	1273	200 A	282	242	-	400 A-SB	415	340	265	M63 x 1.5	55
IE3-W41R 315 MX2	315	211	1200	1378	400 A-SB	415	340	265	630 A	496	390	301	M63 x 1.5	55
IE3-W41R 315 MY2	315	230	1270	1448	400 A-SB	415	340	265	630 A	496	390	301	M63 x 1.5	55
IE3-W41R 315 L2	315	230	1390	1568	400 A-SB	415	340	265	630 A	496	390	301	M63 x 1.5	55
IE3-W41R 315 LX2	315	230	1510	1688	400 A-SB	415	340	265	630 A	496	390	301	M63 x 1.5	55
IE3-W41R 315 S4	315	211	1080	1248	200 A	282	242	-	400 A-SB	415	340	265	M63 x 1.5	55
IE3-W41R 315 M4	315	211	1135	1303	200 A	282	242	-	400 A-SB	415	340	265	M63 x 1.5	55
IE3-W41R 315 MX4	315	230	1230	1408	400 A-SB	415	340	265	630 A	496	390	301	M63 x 1.5	55
IE3-W41R 315 MY4	315	230	1300	1478	400 A-SB	415	340	265	630 A	496	390	301	M63 x 1.5	55
IE3-W41R 315 L4	315	230	1420	1598	400 A-SB	415	340	265	630 A	496	390	301	M63 x 1.5	55
IE3-W41R 315 LX4	315	230	1540	1718	400 A-SB	415	340	265	630 A	496	390	301	M63 x 1.5	55
IE3-W41R 315 S6	315	211	1135	1303	200 A	282	242	-	400 A-SB	415	340	265	M63 x 1.5	55
IE3-W41R 315 M6	315	230	1300	1478	400 A-SB	415	340	265	630 A	496	390	301	M63 x 1.5	55
IE3-W41R 315 MX6	315	230	1300	1478	400 A-SB	415	340	265	630 A	496	390	301	M63 x 1.5	55
IE3-W41R 315 L6	315	230	1420	1598	400 A-SB	415	340	265	630 A	496	390	301	M63 x 1.5	55
IE3-W41R 315 S8	315	211	1135	1303	200 A	282	242	-	400 A-SB	415	340	265	M63 x 1.5	55
IE3-W41R 315 M8	315	230	1300	1478	400 A-SB	415	340	265	630 A	496	390	301	M63 x 1.5	55
IE3-W41R 315 MX8	315	230	1300	1478	400 A-SB	415	340	265	630 A	496	390	301	M63 x 1.5	55
IE3-W41R 315 L8	315	230	1420	1598	400 A-SB	415	340	265	630 A	496	390	301	M63 x 1.5	55

**Energy-saving motor for High Efficiency IE2
Three-phase motors with squirrel-cage rotor**

with surface cooling, type of cooling IC 411, degree of protection IP 55
Size 56 to 160

Type of construction IM B3 [IM 1001]

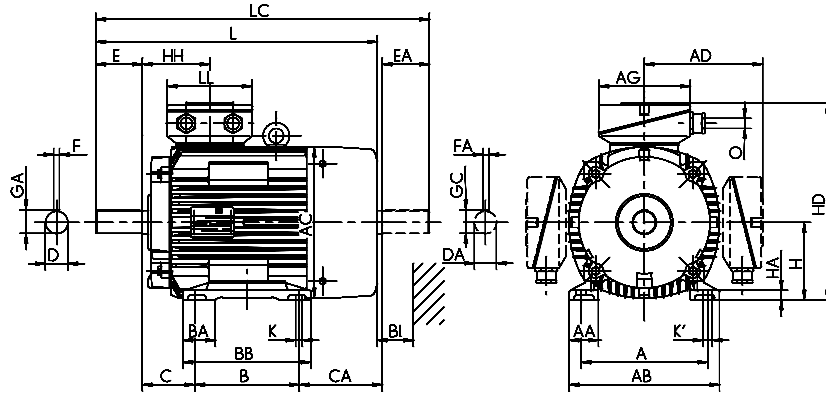

Type designation	Flange size	A	AA	AB	AC	AD	AD VIK	B	BA	BB	C	CA	D	DA	DB ¹⁾	E	EA	F	FA	GA	GC
		b	n	f	g	g1	g1	a	m	e	w1	w2	d	d1	i	l1	u	u1	t	t1	
IE2-W21R 56 K2, 4/G2, 4/WE2R 56 G2	FF 100	90	18	110	109	98	118	71	-	86	36	52	9	-	M3	20	-	3	3	10	10.2
IE2-WE2R 63 K2, 4/G2, 6	FF 115	100	28	128	109	98	118	80	-	100	40	39	11	11	M4	23	23	4	4	13	12.5
IE2-W21R 63 K2, 4/G2, 4/WE1R 63 GY4	FF 115	100	21	120	124	104	124	80	-	95	40	59	11	11	M4	23	23	4	4	13	12.5
IE2-WE2R 71 K2, 4, 6/G2, 6, 8	FF 130	112	32	138	124	104	124	90	-	116	45	43.5	14	14	M5	30	30	5	5	16	16
IE2-W21R 71 K2, 4, 6/G2, 4, 6/WE1R 71 GY4	FF 130	112	24	135	139	111	131	90	-	114	45	78	14	14	M5	30	30	5	5	16	16
IE2-WE2R 80 K2, 4, 6, 8/G2, 8	FF 165	125	38	168	139	111	131	100	-	125	50	63	19	19	M6	40	40	6	6	22	21.5
IE2-W21R 80 K2, 4, 6/WE1R 80 GY4, 6/K8	FF 165	125	26	152	157	120	140	100	-	125	50	80	19	19	M6	40	40	6	6	22	21.5
IE2-W21R 80 G4, 6/WE1R 80 G2	FF 165	125	26	152	157	120	140	100	-	146	50	102	19	19	M6	40	40	6	6	22	21.5
IE2-WE2R 90 S2, 8	FF 165	140	40	178	157	120	140	100	-	130	56	74	24	24	M8	50	50	8	8	27	27
IE2-WE2R 90 S4, 6	FF 165	140	40	178	157	120	140	100	-	130	56	96	24	24	M8	50	50	8	8	27	27
IE2-WE2R 90 L2, 8	FF 165	140	40	178	157	120	140	125	-	155	56	71	24	24	M8	50	50	8	8	27	27
IE2-WE1R 90 S2, 4/W21R S6, 8	FF 165	140	40	178	177	127	147	100	-	130	56	120	24	24	M8	50	50	8	8	27	27
IE2-WE1R 90 L2/LW4, 6	FF 165	140	40	178	177	127	147	125	-	155	56	96	24	24	M8	50	50	8	8	27	27
IE2-WE1R 90 L4/W21R 90 L6, 8	FF 165	140	40	178	177	127	147	125	-	155	56	125	24	24	M8	50	50	8	8	27	27
IE2-WE2R 100 L8	FF 215	160	47	192	177	127	147	140	-	175	63	73	28	24	M10	60	50	8	8	31	27
IE2-WE2R 100 LY2, L6	FF 215	160	47	192	177	127	147	140	-	175	63	103	28	24	M10	60	50	8	8	31	27
IE2-WE1R 100 LX4	FF 215	160	42	193	196	137	156	140	-	175	63	166	28	28	M10	60	60	8	8	31	31
IE2-WE1R 100 L2, S4, LY8/W21R 100 L8	FF 215	160	42	193	196	137	156	140	-	175	63	102	28	28	M10	60	60	8	8	31	31
IE2-WE1R 100 L4, LW4/W21R 100 LX6, 8	FF 215	160	42	193	196	137	156	140	-	175	63	136	28	28	M10	60	60	8	8	31	31
IE2-WE1R 112 ML2, MX2, 6/M8	FF 215	190	52	225	196	136	156	140	-	180	70	129	28	28	M10	60	60	8	8	31	31
IE2-W21R 112 MV2, 6, 8	FF 215	190	52	225	196	136	156	140	-	180	70	159	28	28	M10	60	60	8	8	31	31
IE2-WE1R 112 M2	FF 215	190	52	225	196	136	156	140	-	180	70	95	28	28	M10	60	60	8	8	31	31
IE2-WE1R 112 MZ4, 6	FF 215	190	52	225	196	137	156	140	-	180	70	199	28	28	M10	60	60	8	8	31	31
IE2-WE1R 112 M4	FF 215	190	45	226	217	178	189	140	42	172	70	192	28	28	M10	60	60	8	8	31	31
IE2-WE1R 132 SY2T	FF 265	216	52	256	196	155	175	140	-	180	89	129	38	28	M12	80	60	10	8	41	31
IE2-WE1R 132 S2T, SX2T	FF 265	216	52	256	196	155	175	140	-	180	89	159	38	28	M12	80	60	10	8	41	31
IE2-WE1R 132 S2, 6, 8/WE2R 132 SY4	FF 265	216	50	256	217	178	189	140	53	180	89	173	38	32	M12	80	80	10	10	41	35
IE2-WE1R 132 SX2	FF 265	216	50	256	258	199	210	140	53	180	89	176	38	38	M12	80	80	10	10	41	41
IE2-WE1R 132 M4	FF 265	216	50	256	258	199	210	178	53	218	89	186	38	38	M12	80	80	10	10	41	41
IE2-WE1R 132 MX6	FF 265	216	50	256	258	199	210	178	53	218	89	186	38	38	M12	80	80	10	10	41	41
IE2-WE2R 132 S4	FF 265	216	50	256	217	178	189	140	53	180	89	223	38	32	M12	80	80	10	10	41	35
IE2-WE2R 132 M6, 8	FF 265	216	50	256	217	178	189	178	53	218	89	185	38	32	M12	80	80	10	10	41	35
IE2-WE1R 160 M2	FF 300	254	55	296	313	242	275	210	60	257	108	148	42	42	M16	110	110	12	10	45	41
IE2-WE1R 160 M4	FF 300	254	55	296	313	242	275	210	60	257	108	148	42	42	M16	110	110	12	10	45	41
IE2-WE1R 160 M8	FF 300	254	55	296	258	214	214	210	60	257	108	135	42	38	M16	110	80	12	10	45	41
IE2-WE1R 160 M6, MX8	FF 300	254	55	296	313	242	275	210	60	257	108	148	42	42	M16	110	110	12	10	45	41
IE2-WE1R 160 MX2	FF 300	254	55	296	313	242	275	210	56	257	108	185	42	42	M16	110	110	12	12	45	45
IE2-WE1R 160 L2	FF 300	254	55	296	313	242	275	254	60	301	108	142	42	42	M16	110	110	12	12	45	45
IE2-WE1R 160 L4	FF 300	254	55	296	313	242	275	254	60	301	108	200	42	42	M16	110	110	12	12	45	45
IE2-WE1R 160 L6, 8	FF 300	254	55	296	313	242	275	254	60	301	108	142	42	42	M16	110	110	12	12	45	45
IE2-WE2R 160 M4	FF 300	254	55	296	258	214	210	210	60	257	108	185	42	38	M16	110	80	12	10	45	41
IE2-WE2R 160 M6, MX8	FF 300	254	55	296	258	214	210	210	60	257	108	185	42	38	M16	110	80	12	10	45	41

¹⁾ Centre holes to DIN 332-DS

Energy-saving motor for High Efficiency IE2 Three-phase motors with squirrel-cage rotor

with surface cooling, type of cooling IC 411, degree of protection IP 55
Size 56 to 160

Type of construction IM B35 [IM 2001]

Flange dimensions, see page 2/109

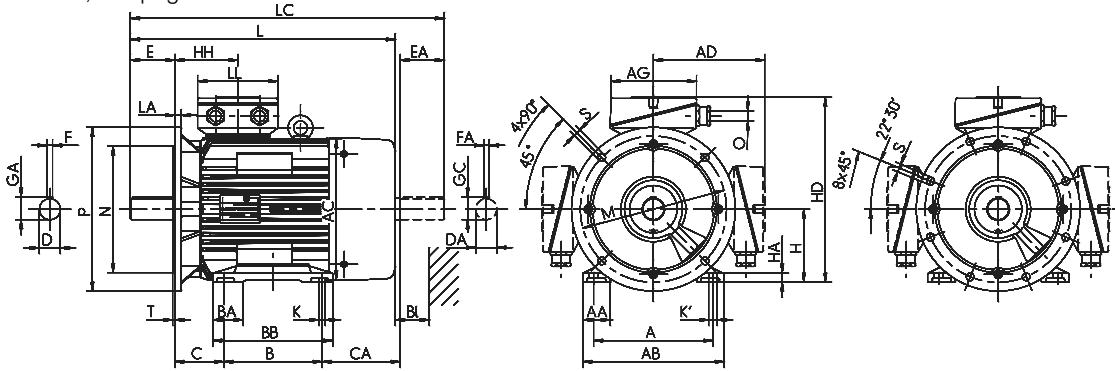

Type designation	H	HA	HD	HD ^{*)}	HD	HH	K	K'	L	LC	TB Type	AG	LL	O	TB Type	AG	LL	O	Loch- bild	Bl
	h	c	p	p	p	A	s	s'	k	k1	Standard	x	z	-	VIK	x	z	-	Bl	Bl
IE2-W21R 56 K2, 4/G2, 4/WE2R 56 G2	56	7	154	***)	174	58	6	6	176	199	KA 05	92	92	M20 x 1.5	KA 05-13	104	112	M20 x 1.5	4L	14
IE2-W2R 63 K2, 4/G2, 6	63	10	161	***)	181	58	8	8	179	205	KA 05	92	92	M20 x 1.5	KA 05-13	104	112	M20 x 1.5	4L	14
IE2-W21R 63 K2, 4/G2, 4/WE1R 63 GY4	63	7.5	167	***)	187	61	7	7	199	225	KA 05	92	92	M20 x 1.5	KA 05-13	104	112	M20 x 1.5	4L	14
IE2-W2R 71 K2, 4, 6/G2, 6, 8	71	11	175	***)	195	61	8	8	206	239	KA 05	92	92	M20 x 1.5	KA 05-13	104	112	M20 x 1.5	4L	14
IE2-W21R 71 K2, 4, 6/G2, 4, 6/WE1R 71 GY4	71	8	182	***)	202	67	7	7	239	273	KA 05	92	92	M20 x 1.5	KA 05-13	104	112	M20 x 1.5	4L	16
IE2-W2R 80 K2, 4, 6, 8/G2, 8	80	12	191	***)	211	67	10	10	249	293	KA 05	92	92	M20 x 1.5	KA 05-13	104	112	M20 x 1.5	4L	16
IE2-W21R 80 K2, 4, 6/WE1R 80 GY4, 6/K8	80	9	200	***)	220	70	10	10	265	310	KA 05	92	92	M20 x 1.5	KA 05-13	104	112	M20 x 1.5	4L	16
IE2-W21R 80 G4, 6/WE1R 80 G2	80	9	200	***)	220	70	10	10	287	332	KA 05	92	92	M20 x 1.5	KA 05-13	104	112	M20 x 1.5	4L	16
IE2-W2R 90 S2, 8	90	14	210	***)	230	70	10	10	275	330	KA 05	92	92	M25 x 1.5	KA 05-13	104	112	M25 x 1.5	4L	16
IE2-W2R 90 S4, 6	90	14	210	***)	230	70	10	10	297	352	KA 05	92	92	M25 x 1.5	KA 05-13	104	112	M25 x 1.5	4L	16
IE2-W2R 90 L2, 8	90	14	210	***)	230	70	10	10	297	352	KA 05	92	92	M25 x 1.5	KA 05-13	104	112	M25 x 1.5	4L	18
IE2-WE1R 90 S2, 4/W21R S6, 8	90	10.5	217	***)	237	75	10	10	321	376	KA 05	92	92	M25 x 1.5	KA 05-13	104	112	M25 x 1.5	4L	18
IE2-WE1R 90 L2/LW4, 6	90	11	217	***)	237	75	10	10	321	376	KA 05	92	92	M25 x 1.5	KA 05-13	104	112	M25 x 1.5	4L	18
IE2-WE1R 90 L4/W21R 90 L6, 8	90	10.5	217	***)	237	75	10	10	351	406	KA 05	92	92	M25 x 1.5	KA 05-13	104	112	M25 x 1.5	4L	18
IE2-W2R 100 L8	100	15	227	***)	247	75	12	12	331	386	KA 05	92	92	M25 x 1.5	KA 05-13	104	112	M25 x 1.5	4L	18
IE2-W2R 100 LY2, L6	100	15	227	***)	247	75	12	12	361	416	KA 05	92	92	M25 x 1.5	KA 05-13	104	112	M25 x 1.5	4L	18
IE2-WE1R 100 LX4	100	13	236	***)	256	77	12	12	421	489	KA 05	92	92	M25 x 1.5	KA 05-13	104	112	M25 x 1.5	4L	20
IE2-WE1R 100 L2, S4, LY8/W21R 100 L8	100	13	236	***)	256	77	12	12	357	425	KA 05	92	92	M25 x 1.5	KA 05-13	104	112	M25 x 1.5	4L	20
IE2-WE1R 100 L4, LW4/W21R 100 LX6, 8	100	13	236	***)	256	77	12	12	391	459	KA 05	92	92	M25 x 1.5	KA 05-13	104	112	M25 x 1.5	4L	20
IE2-WE1R 112 ML2, MX2, 6/M8	112	18	248	***)	268	77	12	12	391	459	KA 05	92	92	M25 x 1.5	KA 05-13	104	112	M25 x 1.5	4L	20
IE2-W21R 112 MV2, 6, 8	112	18	248	***)	268	77	12	12	421	489	KA 05	92	92	M25 x 1.5	KA 05-13	104	112	M25 x 1.5	4L	20
IE2-WE1R 112 M2	112	18	248	***)	268	77	12	12	357	425	KA 05	92	92	M25 x 1.5	KA 05-13	104	112	M25 x 1.5	4L	20
IE2-WE1R 112 MZ4, 6	112	18	248	***)	268	77	12	12	461	529	KA 05	92	92	M25 x 1.5	KA 05-13	104	112	M25 x 1.5	4L	20
IE2-WE1R 112 M4	112	15	290	236.5	297	108	12	12	459	522	25 A	156	145	M32 x 1.5	25 AV	156	145	M32 x 1.5	4L	35
IE2-WE1R 132 SY2T	132	19	287	***)	307	105	12	12	430	498	KA 05 - 13	104	112	M32 x 1.5	KA 05 - 13	104	112	M32 x 1.5	4L	20
IE2-WE1R 132 S2T, SX2T	132	19	287	***)	307	105	12	12	460	528	KA 05 - 13	104	112	M32 x 1.5	KA 05 - 13	104	112	M32 x 1.5	4L	20
IE2-WE1R 132 S2, 6, 8, SY4	132	16	310	256.5	317	108	12	12	479	562	25 A	156	145	M32 x 1.5	25 AV	143	134	M32 x 1.5	4L	35
IE2-WE1R 132 SX2	132	15	331	279	331	114	12	12	481	565	25 A	156	145	M32 x 1.5	25 AV	143	134	M32 x 1.5	4L	35
IE2-WE1R 132 M4	132	15	331	279	331	114	12	12	529	613	25 A	156	145	M32 x 1.5	25 AV	143	134	M32 x 1.5	4L	35
IE2-WE1R 132 MX6	132	15	331	279	331	114	12	12	529	613	25 A	156	145	M32 x 1.5	25 AV	143	134	M32 x 1.5	4L	35
IE2-W2R 132 S4	132	16	310	256.5	310	108	12	12	529	612	25 A	156	145	M32 x 1.5	25 AV	156	145	M32 x 1.5	4L	35
IE2-W2R 132 M6, 8	132	16	310	256.5	310	108	12	12	529	612	25 A	156	145	M32 x 1.5	25 AV	156	145	M32 x 1.5	4L	35
IE2-WE1R 160 M2	160	18	409	336	435	138	15	20	571	686	63 A	193	167	M40 x 1.5	100/63 AV	223	214	M40 x 1.5	4L	35
IE2-WE1R 160 M4	160	18	409	336	435	138	15	20	571	686	63 A	193	167	M40 x 1.5	100/63 AV	223	214	M40 x 1.5	4L	35
IE2-WE1R 160 M8	160	18	363	307	370	138	15	15	559	643	25 A	156	145	M32 x 1.5	25 AV	143	134	M32 x 1.5	4L	35
IE2-WE1R 160 M6, MX8	160	18	409	336	435	138	15	20	571	686	63 A	193	167	M40 x 1.5	100/63 AV	223	214	M40 x 1.5	4L	35
IE2-WE1R 160 MX2	160	18	409	336	435	138	15	20	609	724	63 A	193	167	M40 x 1.5	100/63 AV	223	214	M40 x 1.5	4L	35
IE2-WE1R 160 L2	160	18	409	336	435	138	15	20	609	724	63 A	193	167	M40 x 1.5	100/63 AV	223	214	M40 x 1.5	4L	35
IE2-WE1R 160 L4	160	18	409	336	435	138	15	20	667	783	63 A	193	167	M40 x 1.5	100/63 AV	223	214	M40 x 1.5	4L	35
IE2-WE1R 160 L6, 8	160	18	409	336	435	138	15	20	609	724	63 A	193	167	M40 x 1.5	100/63 AV	223	214	M40 x 1.5	4L	35
IE2-W2R 160 M4	160	18	370	307	370	114	15	15	609	693	63 A	193	167	M40 x 1.5	100/63 AV	223	214	M40 x 1.5	4L	35
IE2-W2R 160 M6, MX8	160	18	370	307	370	114	15	15	609	693	63 A	193	167	M40 x 1.5	100/63 AV	223	214	M40 x 1.5	4L	35

*) Terminal box left/right

Sizes 56/63/71/90: Deviating dimensions C, HH, L, LC for B35, see B5

**) upon request

**Energy-saving motor for High Efficiency IE2
Three-phase motors with squirrel-cage rotor**

with surface cooling, type of cooling IC 411, degree of protection IP 55
Size 180 to 280

Type of construction IM B3 [IM 1001]

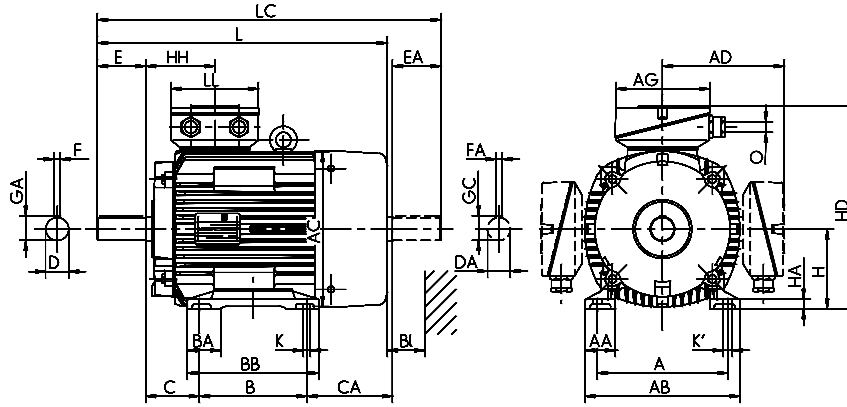

Type designation	Flange size	A	AA	AB	AC	AD	AD	B	BA	BB	C	CA	D	DA	DB ¹⁾	E	EA	F	FA	GA	GC
		b	n	f	g	g1	g1	a	m	e	w1	w2	d	d1		i	l1	u	u1	t	t1
IE2-WE1R 180 M4	FF 300	279	62	328	351	261	294	241	65	288	121	214	48	48	M16	110	110	14	14	51.5	45
IE2-WE1R 180 L4	FF 300	279	62	328	351	261	294	279	65	326	121	176	48	48	M16	110	110	14	14	51.5	51.5
IE2-WE1R 180 L6, 8	FF 300	279	62	328	351	261	294	279	65	326	121	176	48	42	M16	110	110	14	14	51.5	45
IE2-WE2R 180 M4	FF 300	279	62	328	351	261	294	241	65	288	121	194	48	48	M16	110	110	14	14	51.5	51.5
IE2-WE1R 200 L2	FF 350	318	70	372	351	261	294	305	70	360	133	138	55	48	M20	110	110	16	14	59	51.5
IE2-WE1R 200 LX2	FF 350	318	70	372	351	261	294	305	70	360	133	188	55	48	M20	110	110	16	14	59	51.5
IE2-WE1R 200 L4	FF 350	318	70	372	390	300	378	305	70	360	133	193	55	55	M20	110	110	16	16	59	59
IE2-WE1R 200 LX6	FF 350	318	70	372	390	300	378	305	70	360	133	193	55	55	M20	110	110	16	16	59	59
IE2-WE1R 200 L6, 8	FF 350	318	70	372	351	261	294	305	70	360	133	138	55	48	M20	110	110	16	14	59	51.5
IE2-WE1R 225 M2	FF 400	356	75	413	390	300	378	311	75	368	149	211	55	55	M20	110	110	16	16	59	59
IE2-WE1R 225 S4	FF 400	356	75	413	390	300	378	286	75	343	149	196	60	55	M20	140	110	18	16	64	59
IE2-WE1R 225 M4	FF 400	356	75	413	440	324	406	311	75	368	149	267	60	55	M20	140	110	18	16	64	59
IE2-WE1R 225 S8	FF 400	356	75	413	390	300	378	286	75	368	149	211	60	55	M20	140	110	18	16	64	59
IE2-WE1R 225 M6	FF 400	356	75	413	440	324	406	311	75	368	149	267	60	55	M20	140	110	18	16	64	59
IE2-WE1R 225 M8	FF 400	356	75	413	440	324	406	311	75	368	149	267	60	55	M20	140	110	18	16	64	59
IE2-WE2R 225 M4	FF 400	356	75	413	390	300	378	311	75	343	149	261	60	55	M20	140	110	18	16	64	59
IE2-WE2R 225 M6, 8	FF 400	356	75	413	390	300	378	311	75	368	149	221	60	55	M20	140	110	18	16	64	59
IE2-WE1R 250 M4	FF 500	406	84	469	490	386	399	349	84	412	168	275	65	55	M20	140	110	18	16	69	59
IE2-WE1R 250 M6, 8	FF 500	406	84	469	490	386	399	349	84	412	168	275	65	55	M20	140	110	18	16	69	59
IE2-WE2R 250 M4, 6	FF 500	406	84	469	440	386	406	349	84	412	168	325	65	55	M20	140	110	18	16	69	59
IE2-WE1R 280 S2	FF 500	457	94	522	490	386	399	368	96	431	190	234	65	65	M20	140	140	18	18	69	69
IE2-WE1R 280 M2	FF 500	457	94	522	490	386	399	419	96	482	190	229	65	65	M20	140	140	18	18	69	69
IE2-WE1R 280 S4	FF 500	457	94	522	490	386	399	368	96	431	190	234	75	65	M20	140	140	20	18	79.5	69
IE2-WE1R 280 M4	FF 500	457	94	522	490	386	399	419	96	482	190	229	75	65	M20	140	140	20	18	79.5	69
IE2-WE1R 280 S6	FF 500	457	94	522	490	386	399	368	96	431	190	229	75	65	M20	140	140	20	18	79.5	69
IE2-WE1R 280 S8	FF 500	457	94	522	490	386	399	368	96	431	190	229	75	65	M20	140	140	20	18	79.5	69
IE2-WE1R 280 M6, 8	FF 500	457	88	522	550	416	460	419	94	482	190	384	75	65	M20	140	140	20	18	79.5	69

¹⁾ Centre holes to DIN 332-DS

Energy-saving motor for High Efficiency IE2 Three-phase motors with squirrel-cage rotor

with surface cooling, type of cooling IC 411, degree of protection IP 55
Size 180 to 280

Type of construction IM B35 [IM 2001]

Flange dimensions, see page 2/109

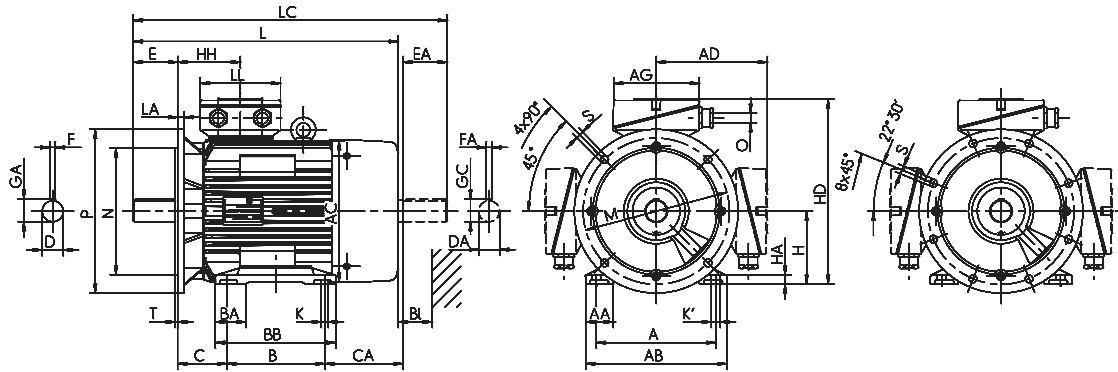

Type designation	H	HA	HD	HD ^{*)}	HD	HH	K	K'	L	LC	TB Type	AG	LL	O	TB Type	AG	LL	O	Hole pattern	Bl.
	h	c	p	p	p	A	s	s'	k	k1	Standard	x	z	-	VIK	x	z	-	Bl	
IE2-WE1R 180 M4	180	20	441	369	476	147	15	20	680	796	63 A	193	167	M40 x 1.5	100/63 AV	223	214	M40 x 1.5	4L	35
IE2-WE1R 180 L4	180	20	441	369	476	147	15	20	680	796	63 A	193	167	M40 x 1.5	100/63 AV	223	214	M40 x 1.5	4L	35
IE2-WE1R 180 L6, 8	180	20	441	369	476	147	15	20	680	796	63 A	193	167	M40 x 1.5	100/63 AV	223	214	M40 x 1.5	4L	35
IE2-WE2R 180 M4	180	20	441	369	476	147	15	20	635	751	63 A	193	167	M40 x 1.5	100/63 AV	223	214	M40 x 1.5	4L	35
IE2-WE1R 200 L2	200	22	461	389	498	147	19	25	680	796	63 A	193	167	M50 x 1.5	100/63 AV	223	214	M50 x 1.5	4L	35
IE2-WE1R 200 LX2	200	22	461	389	498	147	19	25	730	846	63 A	193	167	M50 x 1.5	100/63 AV	223	214	M50 x 1.5	4L	35
IE2-WE1R 200 L4	200	22	500	417	579	168	19	25	727	851	KK 100 A	213	207	M50 x 1.5	200 A-SB	335	270	M50 x 1.5	4L	35
IE2-WE1R 200 LX6	200	22	500	417	579	168	19	25	727	851	KK 100 A	213	207	M50 x 1.5	200 A-SB	335	270	M50 x 1.5	4L	35
IE2-WE1R 200 L6, 8	200	22	461	389	498	147	19	25	680	796	63 A	193	167	M50 x 1.5	100/63 AV	223	214	M50 x 1.5	4L	35
IE2-WE1R 225 M2	225	25	527	442	605	168	19	25	767	891	100 A	213	207	M50 x 1.5	200 A-SB	335	270	M50 x 1.5	8L	40
IE2-WE1R 225 S4	225	25	527	442	605	168	19	25	797	921	100 A	213	207	M50 x 1.5	200 A-SB	335	270	M50 x 1.5	8L	40
IE2-WE1R 225 M4	225	25	549	450	625	177	19	25	862	977	100 A	213	207	M50 x 1.5	200 A-SB	335	270	M50 x 1.5	8L	45
IE2-WE1R 225 S8	225	25	527	442	605	168	19	25	797	921	100 A	213	207	M50 x 1.5	200 A-SB	335	270	M50 x 1.5	8L	40
IE2-WE1R 225 M6	225	25	549	450	625	177	19	25	862	977	100 A	213	207	M50 x 1.5	200 A-SB	335	270	M50 x 1.5	8L	45
IE2-WE1R 225 M8	225	25	549	450	625	177	19	25	862	977	100 A	213	207	M50 x 1.5	200 A-SB	335	270	M50 x 1.5	8L	45
IE2-WE2R 225 M4	225	25	527	442	605	168	19	25	847	971	100 A	213	207	M50 x 1.5	200 A-SB	335	270	M50 x 1.5	8L	40
IE2-W22R 225 M8	225	25	527	442	605	168	19	25	797	921	100 A	213	207	M50 x 1.5	200 A-SB	335	270	M50 x 1.5	8L	40
IE2-WE1R 250 M4	250	28	636	507	647	206	24	30	924	1042	200 A	282	242	M63 x 1.5	200 A-SB	335	270	M63 x 1.5	8L	50
IE2-WE1R 250 M6, 8	250	28	636	507	647	206	24	30	924	1042	200 A	282	242	M63 x 1.5	200 A-SB	335	270	M63 x 1.5	8L	50
IE2-WE2R 250 M4	250	28	636	484	650	177	24	30	912	1027	200 A	282	242	M63 x 1.5	200 A-SB	335	270	M63 x 1.5	8L	50
IE2-WE1R 280 S2	280	32	666	537	677	206	24	30	924	1072	200 A	282	242	M63 x 1.5	200 A-SB	335	270	M63 x 1.5	8L	50
IE2-WE1R 280 M2	280	32	666	537	677	206	24	30	970	1118	200 A	282	242	M63 x 1.5	200 A-SB	335	270	M63 x 1.5	8L	50
IE2-WE1R 280 S4	280	32	666	537	677	206	24	30	924	1072	200 A	282	242	M63 x 1.5	200 A-SB	335	270	M63 x 1.5	8L	50
IE2-WE1R 280 M4	280	32	666	537	677	206	24	30	970	1118	200 A	282	242	M63 x 1.5	200 A-SB	335	270	M63 x 1.5	8L	50
IE2-WE1R 280 S6	280	32	666	537	677	206	24	30	970	1118	200 A	282	242	M63 x 1.5	200 A-SB	335	270	M63 x 1.5	8L	50
IE2-WE1R 280 S8	280	32	666	537	677	206	24	30	970	1118	200 A	282	242	M63 x 1.5	200 A-SB	335	270	M63 x 1.5	8L	50
IE2-WE1R 280 M6, 8	280	40	696	575	707	211	24	30	1105	1273	200 A	282	242	M63 x 1.5	200 A-SB	335	270	M63 x 1.5	8L	55

^{*)} Terminal box left/right

Sizes 56/63/71/90: Deviating dimensions C, HH, L, LC for B35, see B5

**Energy-saving motor for High Efficiency IE2
Three-phase motors with squirrel-cage rotor**

with surface cooling, type of cooling IC 411, degree of protection IP 55
Size 315

Type of construction IM B3 [IM 1001]

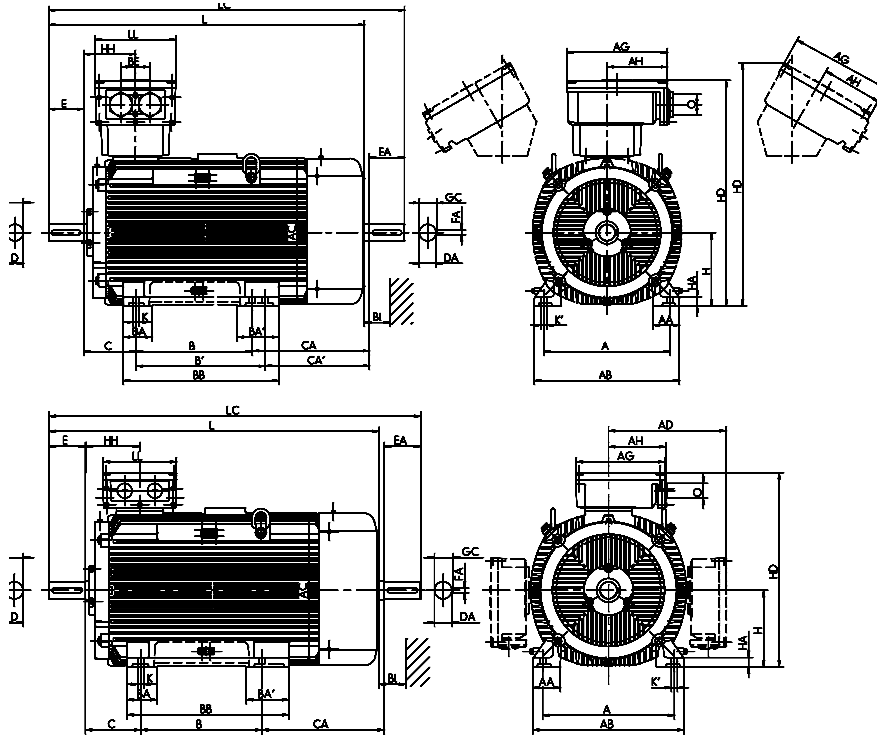

Type designation	Flange size	A	AA	AB	AC	AD	AD	B	BA	BA'	BB	C	CA	D	DA	DB ¹⁾	E	EA	F	FA
		b	n	f	g	g1	g1	a	m	m1	e	w1	w2	d	d1		l	l1	u	u1
IE2-WE1R 315 S2	FF 600	508	126	590	550	416	460	406	120	-	503	216	316	65	65	M20	140	140	18	18
IE2-WE1R 315 M2	FF 600	508	126	590	550	416	460	457	120	150	554	216	320	65	65	M20	140	140	18	18
IE2-WE1R 315 MX2	FF 600	508	126	590	550	416	460	457	120	150	554	216	400	65	65	M20	140	140	18	18
IE2-WE1R 315 MY2	FF 600	508	110	590	610	498	681	457	120	-	573	216	495	65	65	M20	140	140	18	18
IE2-WE1R 315 L2	FF 600	508	110	590	610	498	681	508	120	-	624	216	539	65	65	M20	140	140	18	18
IE2-WE1R 315 LX2	FF 600	508	110	590	610	498	681	508	120	-	624	216	684	65	65	M20	140	140	18	18
IE2-WE1R 315 S4	FF 600	508	126	590	550	416	460	406	120	-	503	216	316	80	70	M20	170	140	22	20
IE2-WE1R 315 M4	FF 600	508	126	590	550	416	460	457	120	150	554	216	320	80	70	M20	170	140	22	20
IE2-WE1R 315 MX4	FF 600	508	126	590	550	416	460	457	120	150	554	216	400	80	70	M20	170	140	22	20
IE2-WE1R 315 MY4	FF 600	508	110	590	610	498	681	457	120	-	573	216	495	80	70	M20	170	140	22	20
IE2-WE1R 315 L4	FF 600	508	110	590	610	498	681	508	120	-	624	216	564	80	70	M20	170	140	22	20
IE2-WE1R 315 LX4	FF 600	508	110	590	610	498	681	508	120	-	624	216	689	80	70	M20	170	140	22	20
IE2-WE1R 315 S6	FF 600	508	126	590	550	416	460	406	120	150	554	216	320	80	70	M20	170	140	22	20
IE2-WE1R 315 M6	FF 600	508	126	590	550	416	460	457	120	150	554	216	320	80	70	M20	170	140	22	20
IE2-WE1R 315 MX6	FF 600	508	110	590	610	498	681	457	120	-	573	216	495	80	70	M20	170	140	22	20
IE2-WE1R 315 MY6	FF 600	508	110	590	610	498	681	457	120	-	573	216	495	80	70	M20	170	140	22	20
IE2-WE1R 315 L6	FF 600	508	110	590	610	498	681	508	120	-	624	216	564	80	70	M20	170	140	22	20
IE2-WE1R 315 LX6	FF 600	508	110	590	610	498	681	508	120	-	624	216	564	80	70	M20	170	140	22	20
IE2-WE1R 315 S8	FF 600	508	126	590	550	416	460	406	120	150	554	216	320	80	70	M20	170	140	22	20
IE2-WE1R 315 M8	FF 600	508	126	590	550	416	460	457	120	150	554	216	320	80	70	M20	170	140	22	20
IE2-WE1R 315 MX8	FF 600	508	110	590	610	498	681	457	120	-	573	216	495	80	70	M20	170	140	22	20
IE2-WE1R 315 MY8	FF 600	508	110	590	610	498	681	457	120	-	573	216	495	80	70	M20	170	140	22	20
IE2-WE1R 315 L8	FF 600	508	110	590	610	498	681	508	120	-	624	216	564	80	70	M20	170	140	22	20
IE2-WE1R 315 LX8	FF 600	508	110	590	610	498	681	508	120	-	624	216	564	80	70	M20	170	140	22	20

¹⁾ Centre holes to DIN 332-DS

Energy-saving motor for High Efficiency IE2 Three-phase motors with squirrel-cage rotor

with surface cooling, type of cooling IC 411, degree of protection IP 55
Size 315

Type of construction IM B35 [IM 2001]

Flange dimensions, see page 2/109

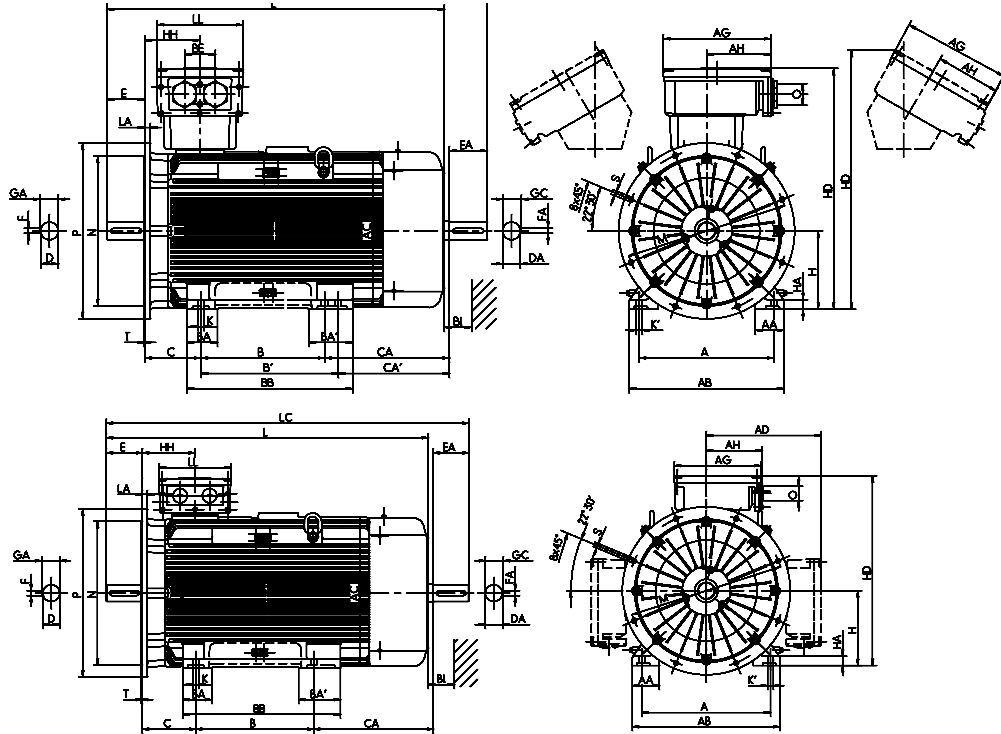

2

Type designation	GA	GC	H	HA	HD	HD**)	HD	HH	K	K'	L	LC	TB Type	AG	LL	AH	TB Type	AG	LL	AH	O	BI
	t	t1	h	c	p	p	p	A	s	s'	k	k1	Standard	x	z	-	VIK	x	z	-	r	BI
IE2-WE1R 315 S2	69	69	315	44	731	610	775	211	28	35	1050	1218	200 A	282	242	-	400 A SB	415	340	265	M63 x 1.5	55
IE2-WE1R 315 M2	69	69	315	44	731	610	775	211	28	35	1105	1273	200 A	282	242	-	400 A SB	415	340	265	M63 x 1.5	55
IE2-WE1R 315 MX2	69	69	315	44	731	610	775	211	28	35	1185	1353	200 A	282	242	-	400 A SB	415	340	265	M63 x 1.5	55
IE2-WE1R 315 MY2	69	69	315	44	809	628	996	230	28	35	1270	1448	400 A SB	415	340	265	630 A	496	390	301	M63 x 1.5	55
IE2-WE1R 315 L2	69	69	315	44	809	628	996	230	28	35	1390	1568	400 A SB	415	340	265	630 A	496	390	301	M63 x 1.5	55
IE2-WE1R 315 LX2	69	69	315	44	809	628	996	230	28	35	1510	1688	400 A SB	415	340	265	630 A	496	390	301	M63 x 1.5	55
IE2-WE1R 315 S4	85	75	315	44	731	610	775	211	28	35	1080	1248	200 A	282	242	-	400 A SB	415	340	265	M63 x 1.5	55
IE2-WE1R 315 M4	85	75	315	44	731	610	775	211	28	35	1135	1303	200 A	282	242	-	400 A SB	415	340	265	M63 x 1.5	55
IE2-WE1R 315 MX4	85	75	315	44	731	610	775	211	28	35	1215	1383	200 A	282	242	-	400 A SB	415	340	265	M63 x 1.5	55
IE2-WE1R 315 MY4	85	75	315	44	809	628	996	230	28	35	1300	1478	400 A SB	415	340	265	630 A	496	390	301	M63 x 1.5	55
IE2-WE1R 315 L4	85	75	315	44	809	628	996	230	28	35	1420	1598	400 A SB	415	340	265	630 A	496	390	301	M63 x 1.5	55
IE2-WE1R 315 LX4	85	75	315	44	809	628	996	230	28	35	1540	1718	400 A SB	415	340	265	630 A	496	390	301	M63 x 1.5	55
IE2-WE1R 315 S6	85	75	315	44	731	610	775	211	28	35	1135	1303	200 A	282	242	-	400 A SB	415	340	265	M63 x 1.5	55
IE2-WE1R 315 M6	85	75	315	44	731	610	775	211	28	35	1135	1303	200 A	282	242	265	400 A SB	415	340	265	M63 x 1.5	55
IE2-WE1R 315 MX6	85	75	315	44	809	628	996	230	28	35	1300	1478	400 A SB	415	340	265	630 A	496	390	301	M63 x 1.5	55
IE2-WE1R 315 MY6	85	75	315	44	809	628	996	230	28	35	1300	1478	400 A SB	415	340	265	630 A	496	390	301	M63 x 1.5	55
IE2-WE1R 315 L6	85	75	315	44	809	628	996	230	28	35	1420	1598	400 A SB	415	340	265	630 A	496	390	301	M63 x 1.5	55
IE2-WE1R 315 LX6	85	75	315	44	809	628	996	230	28	35	1420	1598	400 A SB	415	340	265	630 A	496	390	301	M63 x 1.5	55
IE2-WE1R 315 S8	85	75	315	44	731	610	775	211	28	35	1135	1303	200 A	282	242	-	400 A SB	415	340	265	M63 x 1.5	55
IE2-WE1R 315 M8	85	75	315	44	731	610	775	211	28	35	1135	1303	200 A	282	242	-	400 A SB	415	340	265	M63 x 1.5	55
IE2-WE1R 315 MX8	85	75	315	44	809	628	996	230	28	35	1300	1478	400 A SB	415	340	265	630 A	496	390	301	M63 x 1.5	55
IE2-WE1R 315 MY8	85	75	315	44	809	628	996	230	28	35	1300	1478	400 A SB	415	340	265	630 A	496	390	301	M63 x 1.5	55
IE2-WE1R 315 L8	85	75	315	44	809	628	996	230	28	35	1420	1598	400 A SB	415	340	265	630 A	496	390	301	M63 x 1.5	55
IE2-WE1R 315 LX8	85	75	315	44	809	628	996	230	28	35	1420	1598	400 A SB	415	340	265	630 A	496	390	301	M63 x 1.5	55

** Terminal box left/right

**Energy-saving motor for High Efficiency IE2
Three-phase motors with squirrel-cage rotor**

with surface cooling, type of cooling IC 411, degree of protection IP 55
Size 355

Type of construction IM B3 [IM 1001]

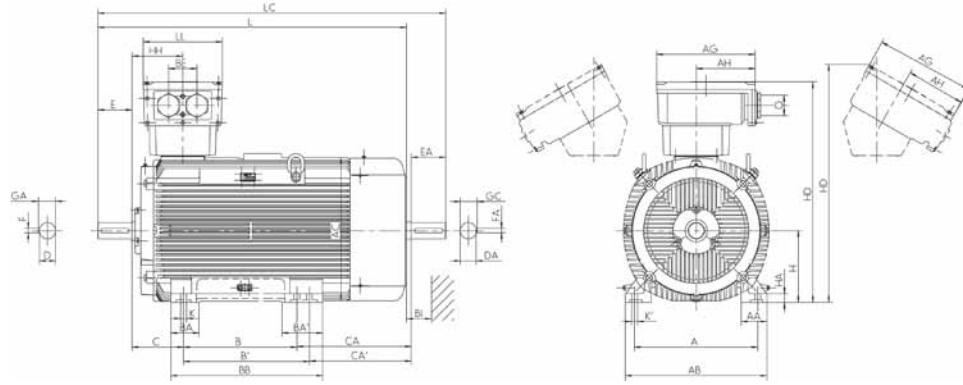

Type designation	Flange size	A	AA	AB	AC	B	BA	BA'	BB	C	CA	D	DA	DB ¹⁾	E	EA	F	FA
		b	n	f	g	a	m	m1	e	w1	w2	d	d1		l	l1	u	u1
IE2-WE2R 355 M2	FF 740	610	130	700	715	560	140	200	750	254	561	80	80	M20	170	170	22	22
IE2-WE2R 355 M4	FF 740	610	130	700	715	560	140	200	750	254	561	100	80	M24	210	170	28	22
IE2-WE2R 355 M6, 8	FF 740	610	130	700	715	560	140	200	750	254	561	100	80	M24	210	170	28	22
IE2-WE2R 355 MX6, 8	FF 740	610	130	700	715	560	140	200	750	254	681	100	80	M24	210	170	28	22
IE2-WE2R 355 MX2	FF 740	610	130	700	715	560	140	200	750	254	681	80	80	M20	170	170	22	22
IE2-WE2R 355 LY2, L2	FF 740	610	130	700	715	630	140	200	750	254	611	80	80	M20	170	170	22	22
IE2-WE2R 355 MX4	FF 740	610	130	700	715	560	140	200	750	254	681	100	80	M24	210	170	28	22
IE2-WE2R 355 LY4, L4	FF 740	610	130	700	715	630	140	200	750	254	611	100	80	M24	210	170	28	22
IE2-WE2R 355 LY6, 8	FF 740	610	130	700	715	630	140	200	750	254	611	100	80	M24	210	170	28	22

¹⁾ Centre holes to DIN 332-DS

²⁾ Terminal box inclined left/right

Energy-saving motor for High Efficiency IE2 Three-phase motors with squirrel-cage rotor

with surface cooling, type of cooling IC 411, degree of protection IP 55
Size 355

Type of construction IM B35 [IM 2001]

Flange dimensions, see page 2/109

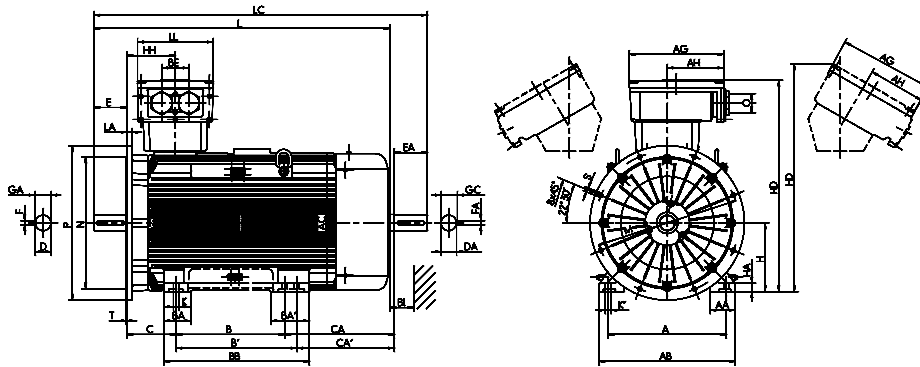

Type designation	GA	GC	H	HA	HD	HD ⁽¹⁾	HH	K	K'	L	LC	TB Type Standard	AG	LL	AH	BE	O	BI
	t	t1	h	c	p	p	A	s	s'	k	k1	VIK	x	z	-	-	r	Bl
IE2-WE2R 355 M2	85	85	355	44	1091	1172	250	28	35	1530	1715	630 A	496	390	301	140	M72 x 2	60
IE2-WE2R 355 M4	106	85	355	44	1091	1172	250	28	35	1570	1755	630 A	496	390	301	140	M72 x 2	60
IE2-WE2R 355 M6, 8	106	85	355	44	1091	1172	250	28	35	1570	1755	630 A	496	390	301	140	M72 x 2	60
IE2-WE2R 355 MX6, 8	106	85	355	44	1091	1172	327	28	35	1690	1875	630 A	496	390	301	140	M72 x 2	60
IE2-WE2R 355 MX2	85	85	355	44	1083	1174	327	28	35	1650	1835	1000 A	615	474	385	200	M72 x 2	60
IE2-WE2R 355 LY2, L2	85	85	355	44	1083	1174	327	28	35	1650	1835	1000 A	615	474	385	200	M72 x 2	60
IE2-WE2R 355 MX4	106	85	355	44	1083	1174	327	28	35	1690	1875	1000 A	615	474	385	200	M72 x 2	60
IE2-WE2R 355 LY4, L4	106	85	355	44	1083	1174	327	28	35	1690	1875	1000 A	615	474	385	200	M72 x 2	60
IE2-WE2R 355 LY6, 8	106	85	355	44	1083	1174	327	28	35	1690	1875	1000 A	615	474	385	200	M72 x 2	60

**Energy-saving motor for High Efficiency IE2
Three-phase motors with squirrel-cage rotor**

with surface cooling, type of cooling IC 411, degree of protection IP 55
Size 56 to 160

Type of construction IM B14 [IM 3601]

Flange dimensions, see page 2/109

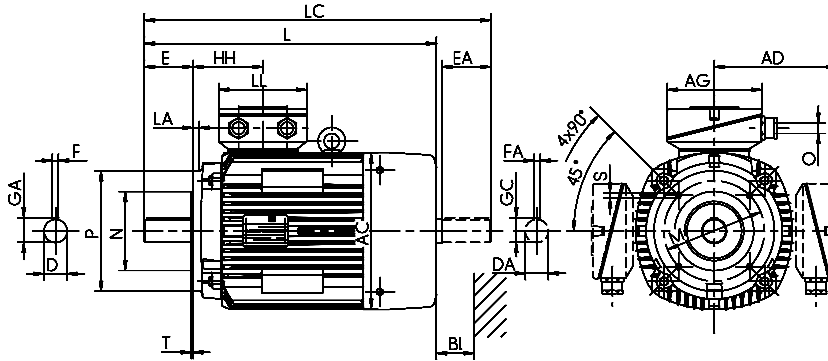

Type designation	Flange size		A	AA	AB	AC	AD	AD	B	BA	BB	C	CA	D	DA	DB ¹⁾	E	EA	F	FA
	small	large	b	n	f	g	g1	g1	a	m	e	w1	w2	d	d1		l	l1	u	u1
			VIK																	
IE2-W21R 56 K2, 4/G2, 4/WE2R 56 G2	FT 65	FT 85	90	18	110	109	98	118	71	-	86	36	52	9	-	M3	20	-	3	3
IE2-WE2R 63 K2, 4/G2, 6	FT 75	FT 100	100	28	128	109	98	118	80	-	100	40	39	11	11	M4	23	23	4	4
IE2-W21R 63 K2, 4/G2, 4/WE1R 63 GY4	FT 75	FT 100	100	21	120	124	104	124	80	-	95	40	59	11	11	M4	23	23	4	4
IE2-WE2R 71 K2, 4, 6/G2, 6, 8	FT 85	FT 115	112	32	138	124	104	124	90	-	116	45	43.5	14	14	M5	30	30	5	5
IE2-W21R 71 K2, 4, 6/G2, 4, 6/WE1R 71 GY4	FT 85	FT 115	112	24	135	139	111	131	90	-	114	45	78	14	14	M5	30	30	5	5
IE2-WE2R 80 K2, 4, 6, 8/G2, 8	FT 100	FT 130	125	38	168	139	111	131	100	-	125	50	63	19	19	M6	40	40	6	6
IE2-W21R 80 K2, 4, 6/WE1R 80 GY4, 6/K8	FT 100	FT 130	125	26	152	157	120	140	100	-	125	50	80	19	19	M6	40	40	6	6
IE2-W21R 80 G4, 6/WE1R 80 G2	FT 100	FT 130	125	26	152	157	120	140	100	-	146	50	102	19	19	M6	40	40	6	6
IE2-WE2R 90 S2, 8	FT 115	FT 130	140	40	178	157	120	140	100	-	130	56	74	24	24	M8	50	50	8	8
IE2-WE2R 90 S4, 6	FT 115	FT 130	140	40	178	157	120	140	100	-	130	56	96	24	24	M8	50	50	8	8
IE2-WE2R 90 L2, 8	FT 115	FT 130	140	40	178	157	120	140	125	-	155	56	71	24	24	M8	50	50	8	8
IE2-WE1R 90 S2, 4/W21R S6, 8	FT 115	FT 130	140	40	178	177	127	147	100	-	130	56	120	24	24	M8	50	50	8	8
IE2-WE1R 90 L2/LW4, 6	FT 115	FT 130	140	40	178	177	127	147	125	-	155	56	96	24	24	M8	50	50	8	8
IE2-WE1R 90 L4/W21R 90 L6, 8	FT 115	FT 130	140	40	178	177	127	147	125	-	155	56	125	24	24	M8	50	50	8	8
IE2-WE2R 100 L8	FT 130	FT 165	160	47	192	177	127	147	140	-	175	63	73	28	24	M10	60	50	8	8
IE2-WE2R 100 LY2, L6	FT 130	FT 165	160	47	192	177	127	147	140	-	175	63	103	28	24	M10	60	50	8	8
IE2-WE1R 100 LX4	FT 130	FT 165	160	42	193	196	137	156	140	-	175	63	166	28	28	M10	60	60	8	8
IE2-WE1R 100 L2, S4, LY8/W21R 100 L8	FT 130	FT 165	160	42	193	196	137	156	140	-	175	63	102	28	28	M10	60	60	8	8
IE2-WE1R 100 L4, LW4/W21R 100 LX6, 8	FT 130	FT 165	160	42	193	196	137	156	140	-	175	63	136	28	28	M10	60	60	8	8
IE2-WE1R 112 ML2, MX2, 6/M8	FT 130	FT 165	190	52	225	196	136	156	140	-	180	70	129	28	28	M10	60	60	8	8
IE2-W21R 112 MV2, 6, 8	FT 130	FT 165	190	52	225	196	136	156	140	-	180	70	159	28	28	M10	60	60	8	8
IE2-WE1R 112 M2	FT 130	FT 165	190	52	225	196	136	156	140	-	180	70	95	28	28	M10	60	60	8	8
IE2-WE1R 112 MZ4, 6	FT 130	FT 165	190	52	225	196	137	156	140	-	180	70	199	28	28	M10	60	60	8	8
IE2-WE1R 112 M4	FT 130	FT 165	190	45	226	217	178	178	140	42	172	70	192	28	28	M10	60	60	8	8
IE2-WE1R 132 SY2T	FT 165	FT 215	216	52	256	196	155	175	140	-	180	89	129	38	28	M12	80	60	10	8
IE2-WE1R 132 S2T, SX2T	FT 165	FT 215	216	52	256	196	155	175	140	-	180	89	159	38	28	M12	80	60	10	8
IE2-WE1R 132 S2, 6, 8/WE2R 132 SY4	FT 165	FT 215	216	50	256	217	178	178	140	55	180	89	173	38	32	M12	80	80	10	10
IE2-WE2R 132 S4	FT 165	FT 215	216	50	256	217	178	178	140	55	180	89	223	38	32	M12	80	80	10	10
IE2-WE2R 132 M6, 8	FT 165	FT 215	216	50	256	217	178	178	178	55	218	89	185	38	32	M12	80	80	10	10
IE2-WE1R 132 SX2	FT 165	FT 215	216	50	256	258	199	258	140	55	180	89	176	38	38	M12	80	80	10	10
IE2-WE1R 132 M4	FT 165	FT 215	216	50	256	258	199	258	178	55	218	89	186	38	38	M12	80	80	10	10
IE2-WE1R 132 MX6	FT 165	FT 215	216	50	256	258	199	258	178	55	218	89	186	38	38	M12	80	80	10	10
IE2-WE1R 160 M2	FT 215	FT 268	254	55	296	313	242	275	210	60	257	108	185	42	42	M16	110	110	12	10
IE2-WE1R 160 M4	FT 215	FT 268	254	55	296	313	242	275	210	60	257	108	178	42	42	M16	110	110	12	10
IE2-WE1R 160 M8	FT 165	FT 215	254	55	296	258	214	210	210	60	257	108	135	42	38	M16	110	80	12	10
IE2-WE1R 160 M6, MX8	FT 215	FT 265	254	55	296	313	242	275	210	60	257	108	148	42	42	M16	110	110	12	10
IE2-WE1R 160 MX2	FT 215	FT 265	254	55	296	313	242	275	210	56	257	108	185	42	42	M16	110	110	12	12
IE2-WE1R 160 L2	FT 215	FT 265	254	55	296	313	242	275	254	60	301	108	142	42	42	M16	110	110	12	12
IE2-WE1R 160 L4	FT 215	FT 265	254	55	296	313	242	275	254	60	301	108	200	42	42	M16	110	110	12	12
IE2-WE1R 160 L6, 8	FT 215	FT 265	254	55	296	313	242	275	254	60	301	108	142	42	42	M16	110	110	12	12
IE2-WE2R 132 S4	FT 130	FT 165	216	50	256	217	178	217	140	55	180	89	223	38	32	M12	80	80	10	10
IE2-WE2R 132 M6, 8	FT 130	FT 165	216	50	256	217	178	217	178	55	218	89	185	38	32	M12	80	80	10	10
IE2-WE2R 160 M4, 6, MX8	FT 165	FT 215	254	55	296	258	214	210	210	60	257	108	185	42	38	M16	110	80	12	10
IE2-WE2R 160 L4	FT 215	FT 265	254	55	296	313	242	275	254	60	301	108	192	42	42	M16	110	110	12	12

¹⁾ Centre holes to DIN 332-DS

Energy-saving motor for High Efficiency IE2

Three-phase motors with squirrel-cage rotor

with surface cooling, type of cooling IC 411, degree of protection IP 55
 Size 56 to 160

Type of construction IM B34 [IM 2101]

Flange dimensions, see page 2/109

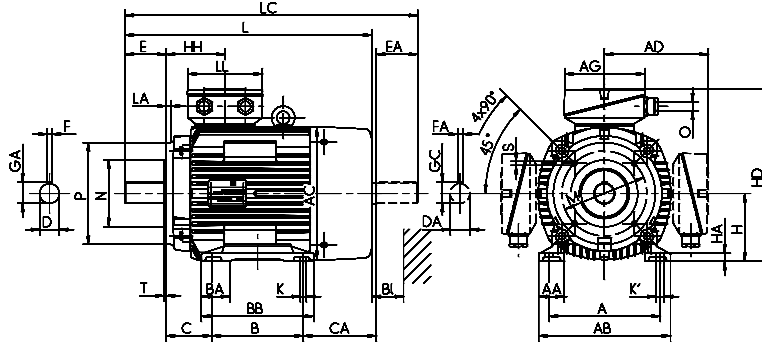

Type designation	GA	GC	H	HA	HD	HD'')	HD	HH	K	K'	L	LC	TB Type	AG	LL	TB Type	AG	LL	O	Hole pattern	
																				Bl	Bl
VIK	t	t1	h	c	p	p	p	A	s	s'	k	k1	Standard	x	z	VIK	x	z	-	Bl	Bl
IE2-W21R 56 K2, 4/G2, 4WE2R 56 G2	10	10.2	56	7	154	***	174	58	6	6	176	199	KA 05	92	92	KA 05-13	104	112	M20 x 1.5	4L	14
IE2-W2R 63 K2, 4/G2, 6	13	12.5	63	10	161	***	181	58	8	8	179	205	KA 05	92	92	KA 05-13	104	112	M20 x 1.5	4L	14
IE2-W21R 63 K2, 4/G2, 4WE1R 63 GY4	13	12.5	63	7.5	167	***	187	61	7	7	199	225	KA 05	92	92	KA 05-13	104	112	M20 x 1.5	4L	14
IE2-W2R 71 K2, 4, 6/G2, 6, 8	16	16	71	11	175	***	195	61	8	8	206	239	KA 05	92	92	KA 05-13	104	112	M20 x 1.5	4L	14
IE2-W21R 71 K2, 4, 6/G2, 4, 6WE1R 71 GY4	16	16	71	8	182	***	202	67	7	7	239	273	KA 05	92	92	KA 05-13	104	112	M20 x 1.5	4L	16
IE2-W2R 80 K2, 4, 6, 8/G2, 8	22	21.5	80	12	191	***	211	67	10	10	249	293	KA 05	92	92	KA 05-13	104	112	M20 x 1.5	4L	16
IE2-W21R 80 K2, 4, 6WE1R 80 GY4, 6/K8	22	21.5	80	9	200	***	220	70	10	10	265	310	KA 05	92	92	KA 05-13	104	112	M20 x 1.5	4L	16
IE2-W21R 80 G4, 6WE1R 80 G2	22	21.5	80	9	200	***	220	70	10	10	287	332	KA 05	92	92	KA 05-13	104	112	M20 x 1.5	4L	16
IE2-W2R 90 S2, 8	27	27	90	14	210	***	230	70	10	10	275	330	KA 05	92	92	KA 05-13	104	112	M25 x 1.5	4L	16
IE2-W2R 90 S4, 6	27	27	90	14	210	***	230	70	10	10	297	352	KA 05	92	92	KA 05-13	104	112	M25 x 1.5	4L	16
IE2-W2R 90 L2, 8	27	27	90	14	210	***	230	70	10	10	297	352	KA 05	92	92	KA 05-13	104	112	M25 x 1.5	4L	18
IE2-W1R 90 S2, 4W21R S6, 8	27	27	90	10.5	217	***	237	75	10	10	321	376	KA 05	92	92	KA 05-13	104	112	M25 x 1.5	4L	18
IE2-W1R 90 L2/LW4, 6	27	27	90	11	217	***	237	75	10	10	321	376	KA 05	92	92	KA 05-13	104	112	M25 x 1.5	4L	18
IE2-W1R 90 L4/W21R 90 L6, 8	27	27	90	10.5	217	***	237	75	10	10	351	406	KA 05	92	92	KA 05-13	104	112	M25 x 1.5	4L	18
IE2-W2R 100 L8	31	27	100	15	227	***	247	75	12	12	331	386	KA 05	92	92	KA 05-13	104	112	M25 x 1.5	4L	18
IE2-W2R 100 LY2, L6	31	27	100	15	227	***	247	75	12	12	361	416	KA 05	92	92	KA 05-13	104	112	M25 x 1.5	4L	18
IE2-W1R 100 LX4	31	31	100	13	236	***	256	77	12	12	421	489	KA 05	92	92	KA 05-13	104	112	M25 x 1.5	4L	20
IE2-W1R 100 L2, S4, LY8/W21R 100 L8	31	31	100	13	236	***	256	77	12	12	357	425	KA 05	92	92	KA 05-13	104	112	M25 x 1.5	4L	20
IE2-W1R 100 L4, LW4/W21R 100 LX6, 8	31	31	100	13	236	***	256	77	12	12	391	459	KA 05	92	92	KA 05-13	104	112	M25 x 1.5	4L	20
IE2-W1R 112 ML2, MX2, 6/M8	31	31	112	18	248	***	268	77	12	12	391	459	KA 05	92	92	KA 05-13	104	112	M25 x 1.5	4L	20
IE2-W21R 112 MV2, 6, 8	31	31	112	18	248	***	268	77	12	12	421	489	KA 05	92	92	KA 05-13	104	112	M25 x 1.5	4L	20
IE2-W1R 112 M2	31	31	112	18	248	***	268	77	12	12	357	425	KA 05	92	92	KA 05-13	104	112	M25 x 1.5	4L	20
IE2-W1R 112 MZ4, 6	31	31	112	18	248	***	268	77	12	12	461	529	KA 05	92	92	KA 05-13	104	112	M25 x 1.5	4L	20
IE2-W1R 112 M4	31	31	112	15	290	236.5	290	108	12	12	459	522	25 A	156	145	25 AV	156	145	M32 x 1.5	4L	35
IE2-W1R 132 SY2T	41	31	132	19	287	***	307	105	12	12	430	498	KA 05-13	104	112	KA 05-13	104	112	M32 x 1.5	4L	20
IE2-W1R 132 S2T, SX2T	41	31	132	19	287	***	307	105	12	12	460	528	KA 05-13	104	112	KA 05-13	104	112	M32 x 1.5	4L	20
IE2-W1R 132 S2, 6, 8WE2R 132 SY4	41	35	132	16	310	256.5	310	108	12	12	479	562	25 A	156	145	25 AV	143	134	M32 x 1.5	4L	35
IE2-W2R 132 S4	41	35	132	16	310	256.5	310	108	12	12	529	612	25 A	156	145	25 AV	143	134	M32 x 1.5	4L	35
IE2-W2R 132 M6, 8	41	35	132	16	310	257.0	310	108	12	12	529	612	25 A	156	145	25 AV	143	134	M32 x 1.5	4L	35
IE2-W1R 132 SX2	41	41	132	15	331	279	331	114	12	12	481	565	25 A	156	145	25 AV	143	134	M32 x 1.5	4L	35
IE2-W1R 132 M4	41	41	132	16	331	279.0	331	114	12	12	529	613	25 A	156	145	25 AV	143	134	M32 x 1.5	4L	35
IE2-W1R 132 MX6	41	41	132	15	331	279	331	114	12	12	529	613	25 A	156	145	25 AV	143	134	M32 x 1.5	4L	35
IE2-W1R 160 M2	45	41	160	18	402	307	435	138	15	15	571	686	63 A	193	167	100/63 AV	223	214	M40 x 1.5	4L	35
IE2-W1R 160 M4	45	41	160	18	402	336	435	138	15	20	571	686	63 A	193	167	100/63 AV	223	214	M40 x 1.5	4L	35
IE2-W1R 160 M8	45	41	160	18	374	307	370	138	15	15	559	643	63 A	193	167	100/63 AV	223	214	M40 x 1.5	4L	35
IE2-W1R 160 M6, MX8	45	41	160	18	402	336	435	138	15	20	571	686	63 A	193	167	100/63 AV	223	214	M40 x 1.5	4L	35
IE2-W1R 160 MX2	45	45	160	18	402	336	435	138	15	20	609	724	63 A	193	167	100/63 AV	223	214	M40 x 1.5	4L	35
IE2-W1R 160 L2	45	45	160	18	402	336	435	138	15	20	609	724	63 A	193	167	100/63 AV	223	214	M40 x 1.5	4L	35
IE2-W1R 160 L4	45	45	160	18	402	336	435	138	15	20	667	783	63 A	193	167	100/63 AV	223	214	M40 x 1.5	4L	35
IE2-W1R 160 L6, 8	45	45	160	18	402	336	435	138	15	20	609	724	63 A	193	167	100/63 AV	223	214	M40 x 1.5	4L	35
IE2-W2R 132 S4	41	35	132	16	310	256.5	310	108	12	12	529	612	25 A	156	145	100/63 AV	223	214	M32 x 1.5	4L	35
IE2-W2R 132 M6, 8	41	35	132	16	310	256.5	310	108	12	12	529	612	25 A	156	145	100/63 AV	223	214	M32 x 1.5	4L	35
IE2-W2R 160 M4, 6, MX8	45	41	160	18	370	307	370	138	15	15	609	693	63 A	193	167	100/63 AV	223	214	M40 x 1.5	4L	35
IE2-W2R 160 L4	45	45	160	18	402	336	435	138	15	20	659	774	63 A	193	167	100/63 AV	223	214	M40 x 1.5	4L	35

*) Terminal box left/right
 ***) upon request

**Energy-saving motor for High Efficiency IE2
Three-phase motors with squirrel-cage rotor**

with surface cooling, type of cooling IC 411, degree of protection IP 55
Size 56 to 280

Type of construction IM B5 [IM 3001]

Type of construction IM V1 [IM 3011]

Flange dimensions, see page 2/109

Type designation	Flange size	AC	AD	AD	D	DA	DB ¹⁾	E	EA	F	FA	GA	GC
		g	g1	g1	d	d1		l	l1	u	u1	t	t1
IE2-W21R 56 K2, 4/G2, 4/WE2R 56 G2	FF 100	109	98	118	9	-	M3	20	-	3	3	10	10.2
IE2-WE2R 63 K2, 4/G2, 6	FF 115	109	98	118	11	11	M4	23	23	4	4	13	12.5
IE2-W21R 63 K2, 4/G2, 4/WE1R 63 GY4	FF 115	124	104	124	11	11	M4	23	23	4	4	13	12.5
IE2-WE2R 71 K2, 4, 6/G2, 6, 8	FF 130	124	104	124	14	14	M5	30	30	5	5	16	16
IE2-W21R 71 K2, 4, 6/G2, 4, 6/WE1R 71 GY4	FF 130	139	111	131	14	14	M5	30	30	5	5	16	16
IE2-WE2R 80 K2, 4, 6, 8/G2, 8	FF 165	139	111	131	19	19	M6	40	40	6	6	22	21.5
IE2-W21R 80 K2, 4, 6/WE1R 80 GY4, 6/K8	FF 165	157	120	140	19	19	M6	40	40	6	6	22	21.5
IE2-W21R 80 G4, 6/WE1R 80 G2	FF 165	157	120	140	19	19	M6	40	40	6	6	22	21.5
IE2-WE2R 90 S2, 8	FF 165	157	120	140	24	24	M8	50	50	8	8	27	27
IE2-WE2R 90 S4, 6	FF 165	157	120	140	24	24	M8	50	50	8	8	27	27
IE2-WE2R 90 L2, 8	FF 165	157	120	140	24	24	M8	50	50	8	8	27	27
IE2-WE1R 90 S2, 4/W21R S6, 8	FF 165	177	127	147	24	24	M8	50	50	8	8	27	27
IE2-WE1R 90 L2/LW4, 6	FF 165	177	127	147	24	24	M8	50	50	8	8	27	27
IE2-WE1R 90 L4/W21R 90 L6, 8	FF 165	177	127	147	24	24	M8	50	50	8	8	27	27
IE2-WE2R 100 L8	FF 215	177	127	147	28	24	M10	60	50	8	8	31	27
IE2-WE2R 100 LY2, L6	FF 215	177	127	147	28	24	M10	60	50	8	8	31	27
IE2-WE1R 100 LX4	FF 215	196	137	156	28	28	M10	60	60	8	8	31	31
IE2-WE1R 100 L2, S4, LY8/W21R 100 L8	FF 215	196	137	156	28	28	M10	60	60	8	8	31	31
IE2-WE1R 100 L4, LW4/W21R 100 LX6, 8	FF 215	196	137	156	28	28	M10	60	60	8	8	31	31
IE2-WE1R 112 ML2, MX2, 6/M8	FF 215	196	136	156	28	28	M10	60	60	8	8	31	31
IE2-W21R 112 MV2, 6, 8	FF 215	196	136	156	28	28	M10	60	60	8	8	31	31
IE2-WE1R 112 M2	FF 215	196	136	156	28	28	M10	60	60	8	8	31	31
IE2-WE1R 112 MZ4, 6	FF 215	196	137	156	28	28	M10	60	60	8	8	31	31
IE2-WE1R 112 M4	FF 215	217	178	189	28	28	M10	60	60	8	8	31	31
IE2-WE1R 132 SY2T	FF 265	196	155	175	38	28	M12	80	60	10	8	41	31
IE2-WE1R 132 S2T/SX2T	FF 265	196	155	175	38	28	M12	80	60	10	8	41	31
IE2-WE1R 132 S2, 6, 8, SY4	FF 265	217	178	189	38	32	M12	80	80	10	10	41	35
IE2-WE2R 132 S4	FF 265	217	178	189	38	32	M12	80	80	10	10	41	35
IE2-WE2R 132 M6, 8	FF 265	217	178	189	38	32	M12	80	80	10	10	41	35
IE2-WE1R 132 SX2	FF 265	258	210	210	38	32	M12	80	80	10	10	41	41
IE2-WE1R 132 M4	FF 265	258	210	210	38	38	M12	80	80	10	10	41	41
IE2-WE1R 132 MX6	FF 265	258	210	210	38	38	M12	80	80	10	10	41	41
IE2-WE1R 160 M2	FF 300	313	242	275	42	38	M16	110	80	12	10	45	41
IE2-WE1R 160 M4	FF 300	313	242	275	42	38	M16	110	80	12	10	45	41
IE2-WE1R 160 M8	FF 300	258	214	214	42	38	M16	110	80	12	10	45	41
IE2-WE1R 160 M6, MX8	FF 300	313	242	275	42	38	M16	110	80	12	10	45	41
IE2-WE1R 160 MX2	FF 300	313	242	275	42	42	M16	110	110	12	12	45	45
IE2-WE1R 160 L2	FF 300	313	242	275	42	42	M16	110	110	12	12	45	45
IE2-WE1R 160 L4	FF 300	313	242	275	42	42	M16	110	110	12	12	45	45
IE2-WE1R 160 L6, 8	FF 300	313	242	275	42	42	M16	110	110	12	12	45	45
IE2-WE1R 180 M2	FF 300	351	261	294	48	48	M16	110	110	14	14	51.5	51.5
IE2-WE1R 180 M4	FF 300	351	261	294	48	42	M16	110	110	14	12	51.5	45
IE2-WE1R 180 L4	FF 300	351	261	294	48	48	M16	110	110	14	14	51.5	51.5
IE2-WE1R 180 L6, 8	FF 300	351	261	294	48	42	M16	110	110	14	12	51.5	45
IE2-WE1R 200 L2	FF 350	351	261	294	55	48	M20	110	110	16	14	59	51.5
IE2-WE1R 200 LX2	FF 350	351	261	294	55	48	M20	110	110	16	14	59	51.5
IE2-WE1R 200 L4	FF 350	390	300	378	55	55	M20	110	110	16	16	59	59
IE2-WE1R 200 LX6	FF 350	390	300	378	55	55	M20	110	110	16	16	59	59
IE2-WE1R 200 L6, 8	FF 350	351	261	294	55	48	M20	110	110	16	14	59	51.5
IE2-WE1R 225 M2	FF 400	390	300	378	55	55	M20	110	110	16	16	59	59
IE2-WE1R 225 S4	FF 400	390	300	378	60	55	M20	140	110	18	16	64	59
IE2-WE1R 225 M4	FF 400	440	324	406	60	55	M20	140	110	18	16	64	59
IE2-WE1R 225 S8	FF 400	390	300	378	60	55	M20	140	110	18	16	64	59
IE2-WE1R 225 M6	FF 400	440	324	406	60	55	M20	140	110	18	16	64	59
IE2-WE1R 225 M8	FF 400	440	324	406	60	55	M20	140	110	18	16	64	59
IE2-WE1R 250 M2	FF 500	440	358	406	60	55	M20	140	110	18	16	64	59
IE2-WE1R 250 M4	FF 500	490	386	399	65	55	M20	140	110	18	16	69	59
IE2-WE1R 250 M6, 8	FF 500	490	386	399	65	55	M20	140	110	18	16	69	59
IE2-WE1R 280 S2	FF 500	490	386	399	65	65	M20	140	140	18	18	69	69
IE2-WE1R 280 M2	FF 500	490	386	399	65	65	M20	140	140	18	18	69	69
IE2-WE1R 280 S4	FF 500	490	386	399	75	65	M20	140	140	20	18	79.5	69
IE2-WE1R 280 M4	FF 500	490	386	399	75	65	M20	140	140	20	18	79.5	69
IE2-WE1R 280 S6	FF 500	490	386	399	75	65	M20	140	140	20	18	79.5	69
IE2-WE1R 280 S8	FF 500	490	386	399	75	65	M20	140	140	20	18	79.5	69
IE2-WE1R 280 M6, 8	FF 500	550	416	460	75	65	M20	140	140	20	18	79.5	69

¹⁾ Centre holes to DIN 332-DS

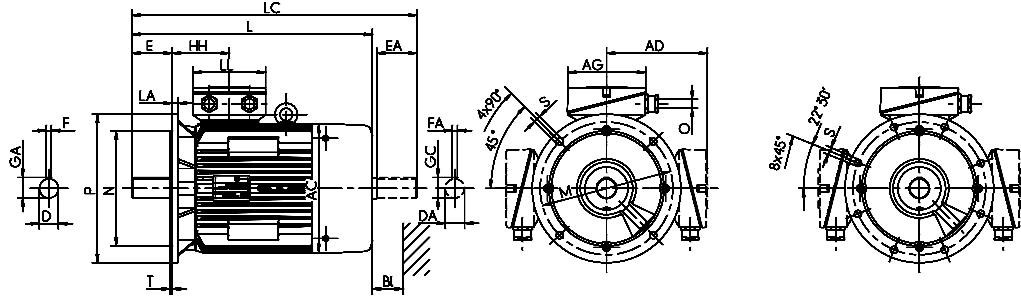

Type designation	H	HH	L	LC	TB Type	AG	LL	TB Type	AG	LL	O	Hole pattern	Bl.
	h	A	k	k1	Standard	x	z	VIK			-		Bl
IE2-W21R 56 K2, 4/G2, 4/WE2R 56 G2	56	81	199	222	KA 05	92	92	KA 05-13	104	112	M20 x 1.5	4L	14
IE2-WE2R 63 K2, 4/G2, 6	63	58	179	205	KA 05	92	92	KA 05-13	104	112	M20 x 1.5	4L	14
IE2-W21R 63 K2, 4/G2, 4/WE1R 63 GY4	63	94	232	258	KA 05	92	92	KA 05-13	104	112	M20 x 1.5	4L	14
IE2-WE2R 71 K2, 4, 6/G2, 6, 8	71	61	206	239	KA 05	92	92	KA 05-13	104	112	M20 x 1.5	4L	14
IE2-W21R 71 K2, 4, 6/G2, 4, 6/WE1R 71 GY4	71	97	269	303	KA 05	92	92	KA 05-13	104	112	M20 x 1.5	4L	16
IE2-WE2R 80 K2, 4, 6, 8/G2, 8	80	67	249	293	KA 05	92	92	KA 05-13	104	112	M20 x 1.5	4L	16
IE2-W21R 80 K2, 4, 6/WE1R 80 GY4, 6/K8	80	70	265	310	KA 05	92	92	KA 05-13	104	112	M20 x 1.5	4L	16
IE2-W21R 80 G4, 6/WE1R 80 G2	80	70	287	332	KA 05	92	92	KA 05-13	104	112	M20 x 1.5	4L	16
IE2-WE2R 90 S2, 8	90	70	275	330	KA 05	92	92	KA 05-13	104	112	M25 x 1.5	4L	16
IE2-WE2R 90 S4, 6	90	70	297	352	KA 05	92	92	KA 05-13	104	112	M25 x 1.5	4L	16
IE2-WE2R 90 L2, 8	90	70	297	352	KA 05	92	92	KA 05-13	104	112	M25 x 1.5	4L	18
IE2-WE1R 90 S2, 4/W21R S6, 8	90	114	360	415	KA 05	92	92	KA 05-13	104	112	M25 x 1.5	4L	18
IE2-WE1R 90 L2/LW4, 6	90	114	360	415	KA 05	92	92	KA 05-13	104	112	M25 x 1.5	4L	18
IE2-WE1R 90 L4/W21R 90 L6, 8	90	114	390	445	KA 05	92	92	KA 05-13	104	112	M25 x 1.5	4L	18
IE2-WE2R 100 L8	100	75	331	386	KA 05	92	92	KA 05-13	104	112	M25 x 1.5	4L	18
IE2-WE2R 100 LY2, L6	100	75	361	416	KA 05	92	92	KA 05-13	104	112	M25 x 1.5	4L	18
IE2-WE1R 100 LX4	100	77	421	489	KA 05	92	92	KA 05-13	104	112	M25 x 1.5	4L	20
IE2-WE1R 100 L2, S4, LY8/W21R 100 L8	100	77	357	425	KA 05	92	92	KA 05-13	104	112	M25 x 1.5	4L	20
IE2-WE1R 100 L4, LW4/W21R 100 LX6, 8	100	77	391	459	KA 05	92	92	KA 05-13	104	112	M25 x 1.5	4L	20
IE2-WE1R 112 ML2, MX2, 6/M8	112	77	391	459	KA 05	92	92	KA 05-13	104	112	M25 x 1.5	4L	20
IE2-W21R 112 MV2, 6, 8	112	77	421	489	KA 05	92	92	KA 05-13	104	112	M25 x 1.5	4L	20
IE2-WE1R 112 M2	112	77	357	425	KA 05	92	92	KA 05-13	104	112	M25 x 1.5	4L	20
IE2-WE1R 112 MZ4, 6	112	77	461	529	KA 05	92	92	KA 05-13	104	112	M25 x 1.5	4L	20
IE2-WE1R 112 M4	112	108	459	522	25 A	156	145	25 AV	156	145	M32 x 1.5	4L	35
IE2-WE1R 132 SY2T	132	105	430	498	KA 05-13	104	112	KA 05-13	104	112	M32 x 1.5	4L	20
IE2-WE1R 132 S2T/SX2T	132	105	460	528	KA 05-13	104	112	KA 05-13	104	112	M32 x 1.5	4L	20
IE2-WE1R 132 S2, 6, 8, SY4	132	108	479	562	25 A	156	145	25 AV	143	134	M32 x 1.5	4L	35
IE2-WE2R 132 S4	132	108	529	612	25 A	156	145	25 AV	143	134	M32 x 1.5	4L	35
IE2-WE2R 132 M6, 8	132	108	529	612	25 A	156	145	25 AV	143	134	M32 x 1.5	4L	35
IE2-WE1R 132 SX2	132	114	481	565	25 A	156	145	25 AV	143	134	M32 x 1.5	4L	35
IE2-WE1R 132 M4	132	114	529	613	25 A	156	145	25 AV	143	134	M32 x 1.5	4L	35
IE2-WE1R 132 MX6	132	114	529	613	25 A	156	145	25 AV	143	134	M32 x 1.5	4L	35
IE2-WE1R 160 M2	160	138	571	656	63 A	193	167	100/63 AV	223	214	M40 x 1.5	4L	35
IE2-WE1R 160 M4	160	138	571	656	63 A	193	167	100/63 AV	223	214	M40 x 1.5	4L	35
IE2-WE1R 160 M8	160	138	559	643	63 A	193	167	100/63 AV	223	214	M40 x 1.5	4L	35
IE2-WE1R 160 M6, MX8	160	138	571	656	63 A	193	167	100/63 AV	223	214	M40 x 1.5	4L	35
IE2-WE1R 160 MX2	160	138	609	724	63 A	193	167	100/63 AV	223	214	M40 x 1.5	4L	35
IE2-WE1R 160 L2	160	138	609	724	63 A	193	167	100/63 AV	223	214	M40 x 1.5	4L	35
IE2-WE1R 160 L4	160	138	667	783	63 A	193	167	100/63 AV	223	214	M40 x 1.5	4L	35
IE2-WE1R 160 L6, 8	160	138	609	724	63 A	193	167	100/63 AV	223	214	M40 x 1.5	4L	35
IE2-WE1R 180 M2	180	147	635	751	63 A	193	167	100/63 AV	223	214	M40 x 1.5	4L	35
IE2-WE1R 180 M4	180	147	680	796	63 A	193	167	100/63 AV	223	214	M40 x 1.5	4L	35
IE2-WE1R 180 L4	180	147	680	796	63 A	193	167	100/63 AV	223	214	M40 x 1.5	4L	35
IE2-WE1R 180 L6, 8	180	147	680	796	63 A	193	167	100/63 AV	223	214	M40 x 1.5	4L	35
IE2-WE1R 200 L2	200	147	680	796	63 A	193	167	100/63 AV	223	214	M40 x 1.5	4L	35
IE2-WE1R 200 LX2	200	147	730	846	63 A	193	167	100/63 AV	223	214	M40 x 1.5	4L	35
IE2-WE1R 200 L4	200	168	727	851	100 A	213	207	200 A-SB	335	270	M50 x 1.5	4L	35
IE2-WE1R 200 LX6	200	168	727	851	100 A	213	207	200 A-SB	335	270	M50 x 1.5	4L	35
IE2-WE1R 200 L6, 8	200	147	680	796	63 A	193	167	100/63 AV	223	214	M50 x 1.5	4L	35
IE2-WE1R 225 M2	225	168	767	891	100 A	213	207	200 A-SB	335	270	M50 x 1.5	8L	40
IE2-WE1R 225 S4	225	168	797	921	100 A	213	207	200 A-SB	335	270	M50 x 1.5	8L	40
IE2-WE1R 225 M4	225	177	862	977	100 A	213	207	200 A-SB	335	270	M50 x 1.5	8L	45
IE2-WE1R 225 S8	225	168	797	921	100 A	213	207	200 A-SB	335	270	M50 x 1.5	8L	40
IE2-WE1R 225 M6	225	177	862	977	100 A	213	207	200 A-SB	335	270	M50 x 1.5	8L	45
IE2-WE1R 225 M8	225	177	862	977	100 A	213	207	200 A-SB	335	270	M50 x 1.5	8L	45
IE2-WE1R 250 M2	250	177	862	977	200 A	282	242	200 A-SB	335	270	M63 x 1.5	8L	45
IE2-WE1R 250 M4	250	206	924	1042	200 A	282	242	200 A-SB	335	270	M63 x 1.5	8L	50
IE2-WE1R 250 M6, 8	250	206	924	1042	200 A	282	242	200 A-SB	335	270	M63 x 1.5	8L	50
IE2-WE1R 280 S2	280	206	924	1072	200 A	282	242	200 A-SB	335	270	M63 x 1.5	8L	50
IE2-WE1R 280 M2	280	206	970	1118	200 A	282	242	200 A-SB	335	270	M63 x 1.5	8L	50
IE2-WE1R 280 S4	280	206	924	1072	200 A	282	242	200 A-SB	335	270	M63 x 1.5	8L	50
IE2-WE1R 280 M4	280	206	970	1118	200 A	282	242	200 A-SB	335	270	M63 x 1.5	8L	50
IE2-WE1R 280 S6	280	206	970	1118	200 A	282	242	200 A-SB	335	270	M63 x 1.5	8L	50
IE2-WE1R 280 S8	280	206	970	1118	200 A	282	242	200 A-SB	335	270	M63 x 1.5	8L	50
IE2-WE1R 280 M6, 8	280	211	1105	1273	200 A	282	242	200 A-SB	335	270	M63 x 1.5	8L	55

**Energy-saving motor for High Efficiency IE2
Three-phase motors with squirrel-cage rotor**

with surface cooling, type of cooling IC 411, degree of protection IP 55
Size 132 to 250

Type of construction IM B5 [IM 3001]

Type of construction IM V1 [IM 3011]

Flange dimensions, see page 2/109

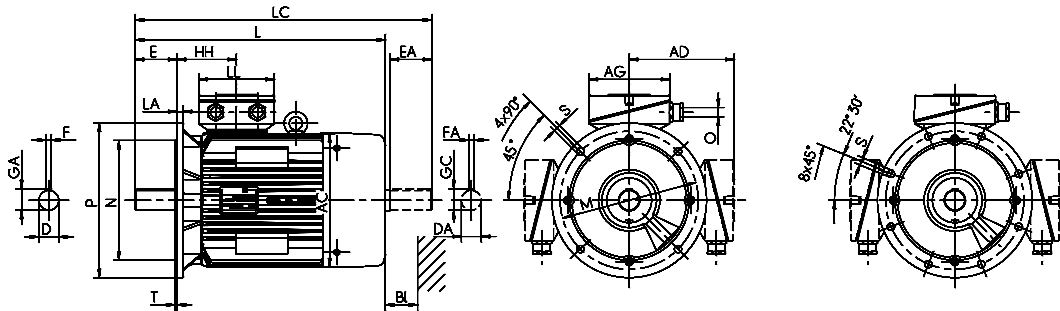

Type designation	Flange size	AC	AD	AD	D	DA	DB ¹⁾	E	EA	F	FA	GA	GC
		g	g1	g1	d	d1		l	l1	u	u1	t	t1
IE2-WE2R 132 S4	FF 265	217	189	189	38	32	M12	80	80	10	10	41	35
IE2-WE2R 132 M6, 8	FF 265	217	189	189	38	32	M12	80	80	10	10	41	35
IE2-WE2R 160 M4	FF 300	258	214	210	42	38	M16	110	80	12	10	45	41
IE2-WE2R 160 M6, MX8	FF 300	258	214	210	42	38	M16	110	80	12	10	45	41
IE2-WE2R 160 L4	FF 300	313	242	275	42	42	M16	110	110	12	12	45	45
IE2-WE2R 180 M4	FF 300	351	261	294	48	48	M16	110	110	14	14	51.5	51.5
IE2-WE2R 200 LX2	FF 350	351	261	294	55	48	M20	110	110	16	14	59	51.5
IE2-WE2R 225 M4	FF 400	390	300	378	60	55	M20	140	110	18	16	64	59
IE2-WE2R 225 M6, 8	FF 400	390	300	378	60	55	M20	140	110	18	16	64	59
IE2-WE2R 250 M6, 8	FF 500	440	386	406	65	55	M20	140	110	18	16	69	59

¹⁾ Centre holes to DIN 332-DS

Type designation	H	HH	L	LC	TB Type	AG	LL	TB Type	AG	LL	0	Hole pattern	Bl.
	h	A	k	k1	Standard	x	z	VIK			-		Bl
IE2-WE2R 132 S4	132	108	529	612	25 A	156	145	25 AV	156	145	M32x1.5	4L	35
IE2-WE2R 132 M6, 8	132	108	529	612	25 A	156	145	25 AV	156	145	M32x1.5	4L	35
IE2-WE2R 160 M4	160	114	609	693	63 A	193	167	100/63 AV	223	214	M40x1.5	4L	35
IE2-WE2R 160 M6, MX8	160	114	609	693	63 A	193	167	100/63 AV	223	214	M40x1.5	4L	35
IE2-WE2R 160 L4	160	138	659	774	63 A	193	167	100/63 AV	223	214	M40x1.5	4L	35
IE2-WE2R 180 M4	180	147	635	751	63 A	193	167	100/63 AV	223	214	M40x1.5	4L	35
IE2-WE2R 200 LX2	200	147	730	846	63 A	193	167	100/63 AV	223	214	M50x1.5	4L	35
IE2-WE2R 225 M4	225	168	847	971	100 A	213	207	200 A-SB	335	270	M50x1.5	8L	40
IE2-WE2R 225 M6, 8	225	168	797	921	100 A	213	207	200 A-SB	335	270	M50x1.5	8L	40
IE2-WE2R 250 M6, 8	250	177	912	1027	200 A	282	242	200 A-SB	335	270	M63x1.5	8L	50

**Energy-saving motor for High Efficiency IE2
Three-phase motors with squirrel-cage rotor**

with surface cooling, type of cooling IC 411, degree of protection IP 55
Size 315

Type of construction IM B5 [IM 3001] to Size 315 MY

Type of construction IM V1 [IM 3011]

Flange dimensions, see page 2/109

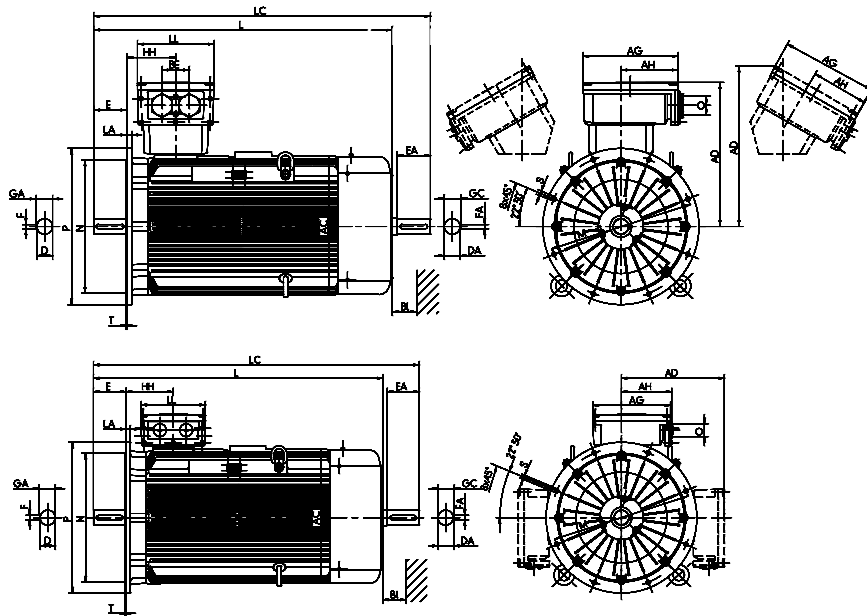

Type designation	Flange size	AC	AD	AD VIK	D	DA	DB ¹⁾	E	EA	F	FA	GA	GC
		g	g1	g1	d	d1		l	l1	u	u1	t	t1
IE2-WE1R 315 S2	FF 600	550	416	460	65	65	M20	140	140	18	18	69	69
IE2-WE1R 315 M2	FF 600	550	416	460	65	65	M20	140	140	18	18	69	69
IE2-WE1R 315 MX2	FF 600	550	416	460	65	65	M20	140	140	18	18	69	69
IE2-WE1R 315 MY2	FF 600	610	498	681	65	65	M20	140	140	18	18	69	69
IE2-WE1R 315 L2	FF 600	610	498	681	65	65	M20	140	140	18	18	69	69
IE2-WE1R 315 LX2	FF 600	610	498	681	65	65	M20	140	140	18	18	69	69
IE2-WE1R 315 S4	FF 600	550	416	460	80	70	M20	170	140	22	20	85	75
IE2-WE1R 315 M4	FF 600	550	416	460	80	70	M20	170	140	22	20	85	75
IE2-WE1R 315 MX4	FF 600	550	416	460	80	70	M20	170	140	22	20	85	75
IE2-WE1R 315 MY4	FF 600	610	498	681	80	70	M20	170	140	22	20	85	75
IE2-WE1R 315 L4	FF 600	610	498	681	80	70	M20	170	140	22	20	85	75
IE2-WE1R 315 LX4	FF 600	610	498	681	80	70	M20	170	140	22	20	85	75
IE2-WE1R 315 S6	FF 600	550	416	460	80	70	M20	170	140	22	20	85	75
IE2-WE1R 315 M6	FF 600	550	416	460	80	70	M20	170	140	22	20	85	75
IE2-WE1R 315 MX6	FF 600	610	498	681	80	70	M20	170	140	22	20	85	75
IE2-WE1R 315 MY6	FF 600	610	498	681	80	70	M20	170	140	22	20	85	75
IE2-WE1R 315 L6	FF 600	610	498	681	80	70	M20	170	140	22	20	85	75
IE2-WE1R 315 LX6	FF 600	610	498	681	80	70	M20	170	140	22	20	85	75
IE2-WE1R 315 S8	FF 600	550	416	460	80	70	M20	170	140	22	20	85	75
IE2-WE1R 315 M8	FF 600	550	416	460	80	70	M20	170	140	22	20	85	75
IE2-WE1R 315 MX8	FF 600	610	498	681	80	70	M20	170	140	22	20	85	75
IE2-WE1R 315 MY8	FF 600	610	498	681	80	70	M20	170	140	22	20	85	75
IE2-WE1R 315 L8	FF 600	610	498	681	80	70	M20	170	140	22	20	85	75
IE2-WE1R 315 LX8	FF 600	610	498	681	80	70	M20	170	140	22	20	85	75

¹⁾ Centre holes to DIN 332-DS

Type designation	H	HH	L	LC	TB Type	AG	LL	AH	TB Type	AG	LL	AH	O	Bl.
	h	A	k	k1	Standard	x	z	-	VIK				r	Bl
IE2-WE1R 315 S2	315	211	1050	1218	200 A	282	242	-	400 A- SB	415	340	265	M63 x 1.5	55
IE2-WE1R 315 M2	315	211	1105	1273	200 A	282	242	-	400 A- SB	415	340	265	M63 x 1.5	55
IE2-WE1R 315 MX2	315	211	1185	1353	200 A	282	242	-	400 A- SB	415	340	265	M63 x 1.5	55
IE2-WE1R 315 MY2	315	230	1270	1448	400 A-SB	415	340	265	630 A	496	390	301	M63 x 1.5	55
IE2-WE1R 315 L2	315	230	1390	1543	400 A-SB	415	340	265	630 A	496	390	301	M63 x 1.5	55
IE2-WE1R 315 LX2	315	230	1510	1688	400 A-SB	415	340	265	630 A	496	390	301	M63 x 1.5	55
IE2-WE1R 315 S4	315	211	1080	1248	200 A	282	242	-	400 A- SB	415	340	265	M63 x 1.5	55
IE2-WE1R 315 M4	315	211	1135	1303	200 A	282	242	-	400 A- SB	415	340	265	M63 x 1.5	55
IE2-WE1R 315 MX4	315	211	1215	1383	200 A	282	242	-	400 A- SB	415	340	265	M63 x 1.5	55
IE2-WE1R 315 MY4	315	230	1300	1478	400 A-SB	415	340	265	630 A	496	390	301	M63 x 1.5	55
IE2-WE1R 315 L4	315	230	1420	1598	400 A-SB	415	340	265	630 A	496	390	301	M63 x 1.5	55
IE2-WE1R 315 LX4	315	230	1540	1723	400 A-SB	415	340	265	630 A	496	390	301	M63 x 1.5	55
IE2-WE1R 315 S6	315	211	1135	1303	200 A	282	242	-	400 A- SB	415	340	265	M63 x 1.5	55
IE2-WE1R 315 M6	315	211	1135	1303	200 A	282	242	265	400 A- SB	415	340	265	M63 x 1.5	55
IE2-WE1R 315 MX6	315	230	1300	1478	400 A-SB	415	340	265	630 A	496	390	301	M63 x 1.5	55
IE2-WE1R 315 MY6	315	230	1300	1478	400 A-SB	415	340	265	630 A	496	390	301	M63 x 1.5	55
IE2-WE1R 315 L6	315	230	1420	1598	400 A-SB	415	340	265	630 A	496	390	301	M63 x 1.5	55
IE2-WE1R 315 LX6	315	230	1420	1598	400 A-SB	415	340	265	630 A	496	390	301	M63 x 1.5	55
IE2-WE1R 315 S8	315	211	1135	1303	200 A	282	242	-	400 A- SB	415	340	265	M63 x 1.5	55
IE2-WE1R 315 M8	315	211	1135	1303	200 A	282	242	-	400 A- SB	415	340	265	M63 x 1.5	55
IE2-WE1R 315 MX8	315	230	1300	1478	400 A-SB	415	340	265	630 A	496	390	301	M63 x 1.5	55
IE2-WE1R 315 MY8	315	230	1300	1478	400 A-SB	415	340	265	630 A	496	390	301	M63 x 1.5	55
IE2-WE1R 315 L6	315	230	1420	1598	400 A-SB	415	340	265	630 A	496	390	301	M63 x 1.5	55
IE2-WE1R 315 LX8	315	230	1420	1598	400 A-SB	415	340	265	630 A	496	390	301	M63 x 1.5	55

Energy-saving motor for High Efficiency IE2 Three-phase motors with squirrel-cage rotor

with surface cooling, type of cooling IC 411, degree of protection IP 55
Size 355

Type of construction IM V1 [IM 3011]

Flange dimensions, see page 2/109

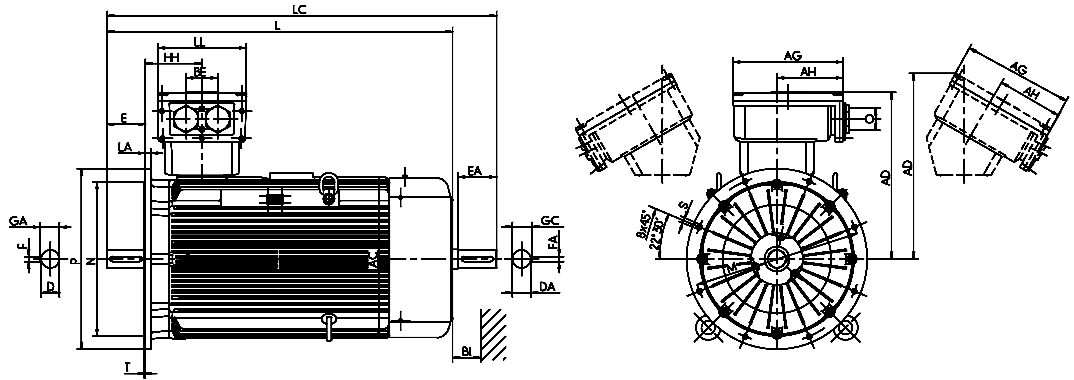

Type designation	Flange size	AC	AD	AD **)	D	DA	DB *)	E	EA	F	FA
		g	g1	g1	d	d1		l	l1	u	u1
IE2-WE2R 355 M2	FF 740	715	736	817	80	80	M20	170	170	22	22
IE2-WE2R 355 M4	FF 740	715	736	817	100	80	M24	210	170	28	22
IE2-WE2R 355 M6, 8	FF 740	715	736	817	100	80	M24	210	170	28	22
IE2-WE2R 355 MX6, 8	FF 740	715	736	817	100	80	M24	210	170	28	22
IE2-WE2R 355 MX2	FF 740	715	728	819	80	80	M20	170	170	22	22
IE2-WE2R 355 LY2, L2	FF 740	715	728	819	80	80	M20	170	170	22	22
IE2-WE2R 355 MX4	FF 740	715	728	819	100	80	M24	210	170	28	22
IE2-WE2R 355 LY, L4	FF 740	715	728	819	100	80	M24	210	170	28	22
IE2-WE2R 355 LY6, 8	FF 740	715	728	819	100	80	M24	210	170	28	22

*) Centre holes to DIN 332-DS

***) Terminal box inclined left/right

Type designation	GA	GC	H	HH	L	LC	TB Type Standard	AG	LL	AH	BE	O	BI.
	t	t1	h	A	K	K1	VK	x	z	-	-	r	BI
IE2-WE2R 355 M2	85	85	355	250	1530	1715	630 A	496	390	301	140	M72 x 2	60
IE2-WE2R 355 M4	106	85	355	250	1570	1755	630 A	496	390	301	140	M72 x 2	60
IE2-WE2R 355 M6, 8	106	85	355	250	1570	1755	630 A	496	390	301	140	M72 x 2	60
IE2-WE2R 355 MX6, 8	106	85	355	327	1690	1875	630 A	496	390	301	140	M72 x 2	60
IE2-WE2R 355 MX2	85	85	355	327	1650	1835	1000 A	615	474	385	200	M72 x 2	60
IE2-WE2R 355 LY2, L2	85	85	355	327	1650	1835	1000 A	615	474	385	200	M72 x 2	60
IE2-WE2R 355 MX4	106	85	355	327	1690	1875	1000 A	615	474	385	200	M72 x 2	60
IE2-WE2R 355 LY, L4	106	85	355	327	1690	1875	1000 A	615	474	385	200	M72 x 2	60
IE2-WE2R 355 LY6, 8	106	85	355	327	1690	1875	1000 A	615	474	385	200	M72 x 2	60

Energy-saving motor for Standard Efficiency IE1
Three-phase motors with squirrel-cage rotor

with surface cooling, type of cooling IC 411, degree of protection IP 55
 Size 56 to 280

Type of construction IM B3 [IM 1001]

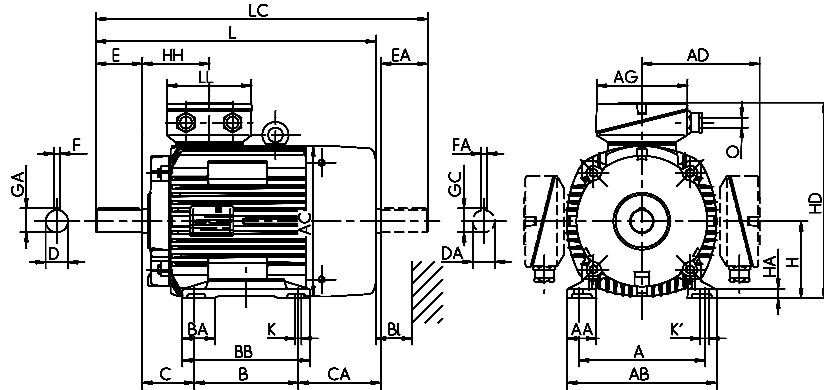

Type designation	Flange size	A	AA	AB	AC	AD	AD	B	BA	BB	C	CA	D	DA	DB ¹⁾	E	EA	F	FA	
		VIK																		
		b	n	f	g	g1	g1	a	m	e	w1	w2	d	d1	l	l1	u	u1		
K210 56 K2, 4 U	FF100	90	18	110	-	98		71	-	86	36	28	9	9	M3	20	20	3	3	
K21R 56 G2, 4	FF100	90	18	110	109	98		71	-	86	36	52	9	9	M3	20	20	3	3	
K21R 63 K2, 4, 6	FF115	100	28	128	109	98		80	-	100	40	39	11	11	M4	23	23	4	4	
K21R 63 G2, 4, 6	FF115	100	28	128	109	98		80	-	100	40	39	11	11	M4	23	23	4	4	
K21R 71 K2, 4, 6, 8	FF130	112	32	138	124	104		90	-	116	45	43.5	14	14	M5	30	30	5	5	
K21R 71 G2, 4, 6, 8	FF130	112	32	138	124	104		90	-	116	45	43.5	14	14	M5	30	30	5	5	
IE1-K21R 80 K2, 4, 6, 8	FF 165	125	38	168	139	111		100	-	125	50	63	19	19	M6	40	40	6	6	
IE1-K21R 80 G2, 4, 6, 8	FF 165	125	38	168	139	111		100	-	125	50	63	19	19	M6	40	40	6	6	
IE1-K21R 90 S2, 4, 6, 8	FF 165	140	40	178	157	119		100	-	130	56	74	24	22	M8	50	50	8	6	
IE1-K21R 90 L2, 4, 6, 8	FF 165	140	40	178	157	119		125	-	155	56	71	24	22	M8	50	50	8	6	
IE1-K21R 100 L2, 4, 6, 8	FF 215	160	47	192	177	126		140	-	175	63	73	28	24	M10	60	50	8	8	
IE1-K21R 100 LX4, 8	FF 215	160	42	193	196	136		140	-	175	63	102	28	28	M10	60	60	8	8	
IE1-K21R 112 M2	FF 215	190	52	225	196	136		140	-	180	70	95	28	28	M10	60	60	8	8	
IE1-K21R 112 M6, 8	FF 215	190	52	225	196	136		140	-	180	70	95	28	28	M10	60	60	8	8	
IE1-K21R 112 MX2	FF 215	190	52	225	196	136		140	-	180	70	129	28	28	M10	60	60	8	8	
IE1-K21R 112 M4	FF 215	190	52	225	196	136		140	-	180	70	129	28	28	M10	60	60	8	8	
IE1-K21R 132 S2, 6, 8T	FF265	216	52	257	196	155		140	-	180	89	129	38	28	M12	80	60	10	8	
IE1-K21R 132 S4T	FF265	216	52	257	196	155		140	-	180	89	129	38	28	M12	80	60	10	8	
IE1-K21R 132 S2	FF265	216	50	256	217	178	189	140	55	180	89	153	38	32	M12	80	80	10	10	
IE1-K21R 132 SX2T	FF265	216	52	257	196	155		140	-	180	89	129	38	28	M12	80	60	10	8	
IE1-K21R 132 SX2	FF265	216	50	256	217	178	189	140	55	180	89	173	38	32	M12	80	80	10	10	
IE1-K21R 132 S4, 6, 8	FF265	216	50	256	217	178	189	140	55	180	89	153	38	32	M12	80	80	10	10	
IE1-K21R 132 M4	FF265	216	50	256	258	199	210	178	55	218	89	138	38	38	M12	80	80	10	10	
IE1-K21R 132 MX6	FF265	216	50	256	258	199	210	178	55	218	89	138	38	38	M12	80	80	10	10	
IE1-K21R 132 M6, 8	FF265	216	50	256	217	178	189	178	55	218	89	135	38	32	M12	80	80	10	10	
IE1-K21R 160 M2	FF300	254	55	296	258	214	214	210	60	257	108	135	42	38	M16	110	80	12	10	
IE1-K21R 160 M4, 6, 8	FF300	254	55	296	258	214	214	210	60	257	108	135	42	38	M16	110	80	12	10	
IE1-K21R 160 MX8	FF300	254	55	296	258	214	214	210	60	257	108	135	42	38	M16	110	80	12	10	
IE1-K21R 160 MX2	FF300	254	55	296	313	242	275	210	60	257	108	148	42	42	M16	110	110	12	12	
IE1-K21R 160 L2, 4, 6, 8	FF300	254	55	296	313	242	275	254	60	301	108	142	42	42	M16	110	110	12	12	
IE1-K21R 180 M2	FF300	279	62	328	351	261	294	241	65	288	121	169	48	48	M16	110	110	14	14	
IE1-K21R 180 M4	FF300	279	62	328	351	261	294	241	65	288	121	142	48	42	M16	110	110	14	12	
IE1-K21R 180 L4	FF300	279	62	328	351	261	294	279	65	326	121	176	48	48	M16	110	110	14	14	
IE1-K21R 180 L6, 8	FF300	279	62	328	351	261	294	279	65	326	121	104	48	42	M16	110	110	14	12	
IE1-K21R 200 L2, 4, 6, 8	FF 350	318	70	372	351	261	294	305	70	360	133	138	55	48	M20	110	110	16	14	
IE1-K21R 200 LX6	FF 350	318	70	372	351	261	294	305	70	360	133	138	55	48	M20	110	110	16	14	
IE1-K21R 200 LX2	FF 350	318	70	372	390	300	378	305	70	360	133	193	55	55	M20	110	110	16	16	
IE1-K21R 225 S4, 8	FF 400	356	75	413	390	300	378	286	75	343	149	196	60	55	M20	140	110	18	16	
IE1-K21R 225 M2	FF 400	356	75	413	390	300	378	311	75	368	149	211	55	55	M20	110	110	16	16	
IE1-K21R 225 M4	FF 400	356	75	413	390	300	378	311	75	368	149	211	60	55	M20	140	110	18	16	
IE1-K21R 225 M6, 8	FF 400	356	75	413	390	300	378	311	75	368	149	171	60	55	M20	140	110	18	16	
IE1-K21R 250 M2	FF 500	406	84	471	440	358	406	349	84	412	168	210	60	55	M20	140	110	18	16	
IE1-K21R 250 M4, 6, 8	FF 500	406	84	471	440	358	406	349	84	412	168	210	65	55	M20	140	110	18	16	
IE1-K21R 280 S2	FF 500	457	94	522	490	386	399	368	96	431	190	234	65	65	M20	140	140	18	18	
IE1-K21R 280 S4, 6, 8	FF 500	457	94	522	490	386	399	368	96	431	190	234	75	65	M20	140	140	20	18	
IE1-K21R 280 M2	FF 500	457	94	522	490	386	399	419	96	482	190	229	65	65	M20	140	140	18	18	
IE1-K21R 280 M4, 6, 8	FF 500	457	94	522	490	386	399	419	96	482	190	229	75	65	M20	140	140	20	18	

¹⁾ Centre holes to DIN 332-DS

Energy-saving motor for Standard Efficiency IE1 Three-phase motors with squirrel-cage rotor

with surface cooling, type of cooling IC 411, degree of protection IP 55
Size 56 to 280

Type of construction IM B35 [IM 2001]

Flange dimensions, see page 2/109

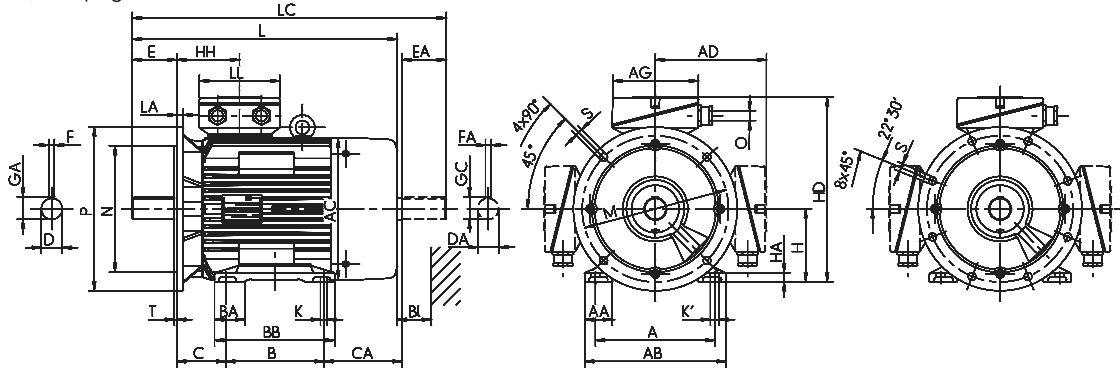

Type designation	GA	GC	H	HA	HD	HD ^{*)}	HD	HH	K	K'	L	LC	TB Type	AG	LL	TB Type	AG	LL	O	Hole pattern	Bl.
	t	t1	h	c	p	p	p	A	s	s'	k	k1		X	Z	VIK	X	Z			Bl
K210 56 K2, 4 U	10.2	10.2	56	7	154	***)		58	6	6	150	175	KA 05	92	92				M20 x 1.5	4L	14
K21R 56 G2, 4	10.2	10.2	56	7	154	***)		58	6	6	176	199	KA 05	92	92				M20 x 1.5	4L	14
K21R 63 K2, 4, 6	12.5	12.5	63	10	161	***)		58	8	8	179	205	KA 05	92	92				M20 x 1.5	4L	14
K21R 63 G2, 4, 6	12.5	12.5	63	10	161	***)		58	8	8	179	205	KA 05	92	92				M20 x 1.5	4L	14
K21R 71 K2, 4, 6, 8	16	16	71	11	175	***)		61	8	8	206	239	KA 05	92	92				M20 x 1.5	4L	14
K21R 71 G2, 4, 6, 8	16	16	71	11	175	***)		61	8	8	206	239	KA 05	92	92				M20 x 1.5	4L	14
IE1-K21R 80 K2, 4, 6, 8	21.5	21.5	80	12	191	***)		67	10	10	249	293	KA 05	92	92				M20 x 1.5	4L	16
IE1-K21R 80 G2, 4, 6, 8	21.5	21.5	80	12	191	***)		67	10	10	249	293	KA 05	92	92				M20 x 1.5	4L	16
IE1-K21R 90 S2, 4, 6, 8	27	24.5	90	14	210	***)		70	10	10	275	330	KA 05	92	92				M25 x 1.5	4L	16
IE1-K21R 90 L2, 4, 6, 8	27	24.5	90	14	210	***)		70	10	10	297	352	KA 05	92	92				M25 x 1.5	4L	16
IE1-K21R 100 L2, 4, 6, 8	31	27	100	15	227	***)		75	12	12	331	386	KA 05	92	92				M25 x 1.5	4L	18
IE1-K21R 100 LX4, 8	31	31	100	13	237	***)		77	12	12	357	425	KA 05	92	92				M25 x 1.5	4L	20
IE1-K21R 112 M2	31	31	112	18	249	***)		77	12	12	357	425	KA 05	92	92				M25 x 1.5	4L	20
IE1-K21R 112 M6, 8	31	31	112	18	249	***)		77	12	12	357	425	KA 05	92	92				M25 x 1.5	4L	20
IE1-K21R 112 MX2	31	31	112	18	249	***)		77	12	12	391	459	KA 05	92	92				M25 x 1.5	4L	20
IE1-K21R 112 M4	31	31	112	18	249	***)		77	12	12	391	459	KA 05	92	92				M25 x 1.5	4L	20
IE1-K21R 132 S2, 6, 8T	41	31	132	18	287	***)		105	12	12	430	498	KA 05-13	104	112				M25 x 1.5	4L	20
IE1-K21R 132 S4T	41	31	132	18	287	***)		105	12	12	460	528	KA 05-13	104	112				M25 x 1.5	4L	20
IE1-K21R 132 S2	41	35	132	16	310	256.5	310	108	12	12	459	542	25 A	156	145	25 AV	143	134	M25 x 1.5	4L	35
IE1-K21R 132 SX2T	41	31	132	18	287	***)		105	12	12	460	528	KA 05-13	104	112				M25 x 1.5	4L	20
IE1-K21R 132 SX2	41	35	132	16	310	256.5	310	108	12	12	479	562	25 A	156	145	25 AV	143	134	M32 x 1.5	4L	35
IE1-K21R 132 S4, 6, 8	41	35	132	16	310	256.5	310	108	12	12	459	542	25 A	156	145	25 AV	143	134	M32 x 1.5	4L	35
IE1-K21R 132 M4	41	41	132	16	331	279	331	114	12	12	481	565	25 A	156	145	25 AV	143	134	M32 x 1.5	4L	35
IE1-K21R 132 MX6	41	41	132	16	331	279	331	114	12	12	481	565	25 A	156	145	25 AV	143	134	M32 x 1.5	4L	35
IE1-K21R 132 M6, 8	41	35	132	16	310	256.5	310	108	12	12	479	562	25 A	156	145	25 AV	143	134	M32 x 1.5	4L	35
IE1-K21R 160 M2	45	41	160	18	363	307	370	114	15	15	559	643	25 A	156	145	25 AV	143	134	M32 x 1.5	4L	35
IE1-K21R 160 M4, 6, 8	45	41	160	18	363	307	370	114	15	15	559	643	25 A	156	145	25 AV	143	134	M32 x 1.5	4L	35
IE1-K21R 160 MX8	45	41	160	18	363	307	370	114	15	15	559	643	25 A	156	145	25 AV	143	134	M32 x 1.5	4L	35
IE1-K21R 160 MX2	45	45	160	18	409	336	435	138	15	20	571	686	63 A	193	167	100/63 AV	223	214	M40 x 1.5	4L	35
IE1-K21R 160 L2, 4, 6, 8	45	45	160	18	409	336	435	138	15	20	609	724	63 A	193	167	100/63 AV	223	214	M40 x 1.5	4L	35
IE1-K21R 180 M2	51.5	51.5	180	20	441	369	476	147	15	20	635	751	63 A	193	167	100/63 AV	223	214	M40 x 1.5	4L	35
IE1-K21R 180 M4	51.5	45	180	20	422	356	459	138	15	20	609	724	63 A	193	167	100/63 AV	223	214	M40 x 1.5	4L	35
IE1-K21R 180 L4	51.5	51.5	180	20	441	369	476	147	15	20	680	796	63 A	193	167	100/63 AV	223	214	M40 x 1.5	4L	35
IE1-K21R 180 L6, 8	51.5	45	180	20	422	369	459	138	15	20	609	724	63 A	193	167	100/63 AV	223	214	M40 x 1.5	4L	35
IE1-K21R 200 L2, 4, 6, 8	59	51.5	200	22	461	389	498	147	19	25	680	796	63 A	193	167	100/63 AV	223	214	M40 x 1.5	4L	35
IE1-K21R 200 LX6	59	51.5	200	22	461	389	498	147	19	25	680	796	63 A	193	167	100/63 AV	223	214	M40 x 1.5	4L	35
IE1-K21R 200 LX2	59	59	200	22	500	417	579	168	19	25	727	851	100 A	213	207	200 A-SB	335	270	M50 x 1.5	4L	35
IE1-K21R 225 S4, 8	64	59	225	25	527	442	605	168	19	25	757	881	100 A	213	207	200 A-SB	335	270	M50 x 1.5	8L	40
IE1-K21R 225 M2	59	59	225	25	527	442	605	168	19	25	767	891	100 A	213	207	200 A-SB	335	270	M50 x 1.5	8L	40
IE1-K21R 225 M4	64	59	225	25	527	442	605	168	19	25	797	921	100 A	213	207	200 A-SB	335	270	M50 x 1.5	8L	40
IE1-K21R 225 M6, 8	64	59	225	25	527	442	605	168	19	25	757	881	100 A	213	207	200 A-SB	335	270	M50 x 1.5	8L	40
IE1-K21R 250 M2	64	59	250	28	608	484	650	177	24	30	862	977	200 A	282	242	200 A-SB	335	270	M63 x 1.5	8L	45
IE1-K21R 250 M4, 6, 8	69	59	250	28	608	484	650	177	24	30	862	977	200 A	282	242	200 A-SB	335	270	M63 x 1.5	8L	45
IE1-K21R 280 S2	69	69	280	32	666	546	677	206	24	30	924	1072	200 A	282	242	200 A-SB	335	270	M63 x 1.5	8L	50
IE1-K21R 280 S4, 6, 8	79.5	69	280	32	666	546	677	206	24	30	924	1072	200 A	282	242	200 A-SB	335	270	M63 x 1.5	8L	50
IE1-K21R 280 M2	69	69	280	32	666	546	677	206	24	30	970	1118	200 A	282	242	200 A-SB	335	270	M63 x 1.5	8L	50
IE1-K21R 280 M4, 6, 8	79.5	69	280	32	666	546	677	206	24	30	970	1118	200 A	282	242	200 A-SB	335	270	M63 x 1.5	8L	50

*) Terminal box left/right
**) upon request

**Energy-saving motor for Standard Efficiency IE1
Three-phase motors with squirrel-cage rotor**

with surface cooling, type of cooling IC 411, degree of protection IP 55
Size 315

Type of construction IM B3 [IM 1001]

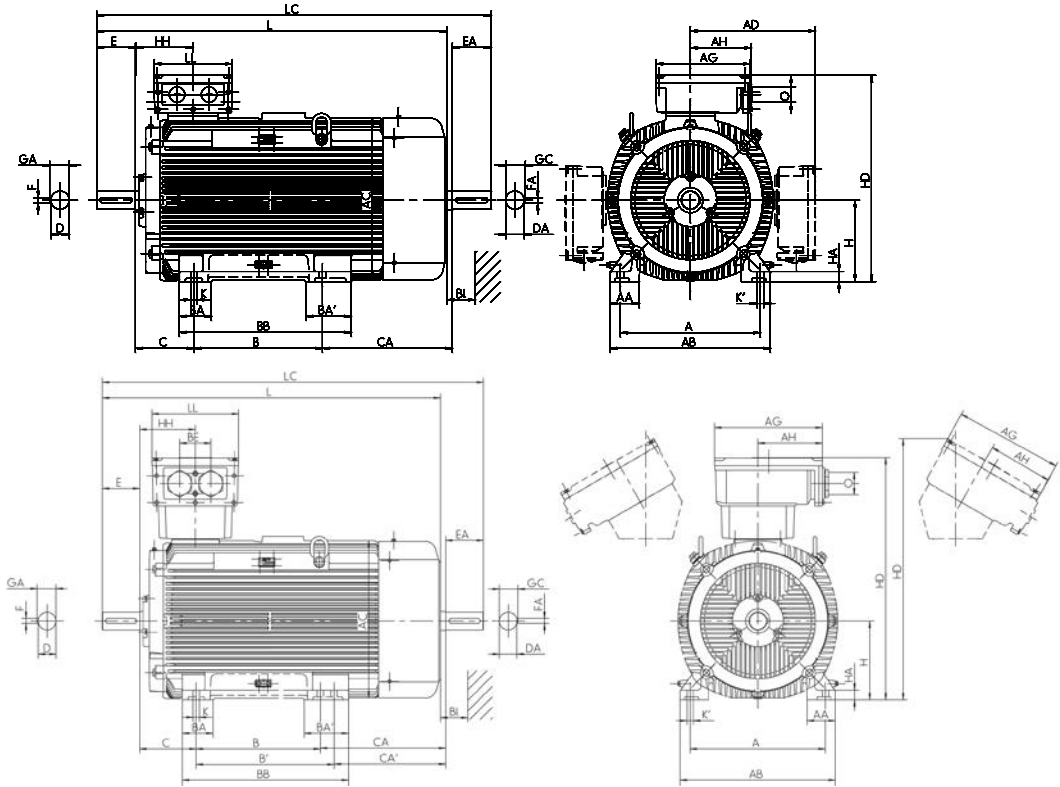

Type designation	Flange size	A	AA	AB	AC	AD	AD	B	BA	BA'	BB	C	CA	D	DA	DB ¹⁾	E	EA	F	FA
		b	n	f	g	g1	g1	a	m	m1	e	w1	w2	d	d1		l	l1	u	u1
IE1-K21R 315 S2	FF 600	508	126	590	550	416	460	406	120	-	503	216	316	65	65	M20	140	140	18	18
IE1-K21R 315 S4, 6, 8	FF 600	508	126	590	550	416	460	406	120	-	503	216	316	80	70	M20	170	140	22	20
IE1-K21R 315 M2	FF 600	508	126	590	550	416	460	457	120	-	554	216	320	65	65	M20	140	140	18	18
IE1-K21R 315 M4, 6, 8	FF 600	508	126	590	550	416	460	457	120	-	554	216	320	80	70	M20	170	140	22	20
IE1-K21R 315 MX2	FF 600	508	126	590	550	416	460	457	120	150	554	216	400	65	65	M20	140	140	18	18
IE1-K21R 315 MX4	FF 600	508	126	590	550	416	460	457	120	150	554	216	400	80	70	M20	170	140	22	20
IE1-K21R 315 MX6, 8	FF 600	508	126	590	550	416	460	457	120	150	554	216	320	80	70	M20	170	140	22	20
IE1-K21R 315 MX10, 12	FF 600	508	126	590	550	416	460	457	120	150	554	216	320	80	70	M20	170	140	22	20
IE1-K21R 315 MY2	FF 600	508	110	590	610	498	681	457	120	-	573	216	495	65	65	M20	140	140	18	18
IE1-K21R 315 MY4, 6, 8	FF 600	508	110	590	610	498	681	457	120	-	573	216	495	80	70	M20	170	140	22	20
IE1-K21R 315 L2	FF 600	508	110	590	610	498	681	508	120	-	624	216	539	65	65	M20	140	140	18	18
IE1-K21R 315 L4, 6, 8	FF 600	508	110	590	610	498	681	508	120	-	624	216	564	80	70	M20	170	140	22	20
IE1-K21R 315 LX2	FF 600	508	110	590	610	481	681	508	120	-	624	216	684	65	65	M20	140	140	18	18
IE1-K21R 315 LX4	FF 600	508	110	590	610	481	681	508	120	-	624	216	689	80	70	M20	170	140	22	20
IE1-K21R 315 LX6, 8	FF 600	508	110	590	610	498	681	508	120	-	624	216	564	80	70	M20	170	140	22	20

¹⁾ Centre holes to DIN 332-DS

Energy-saving motor for Standard Efficiency IE1 Three-phase motors with squirrel-cage rotor

with surface cooling, type of cooling IC 411, degree of protection IP 55
Size 315

Type of construction IM B35 [IM 2001]

Flange dimensions, see page 2/109

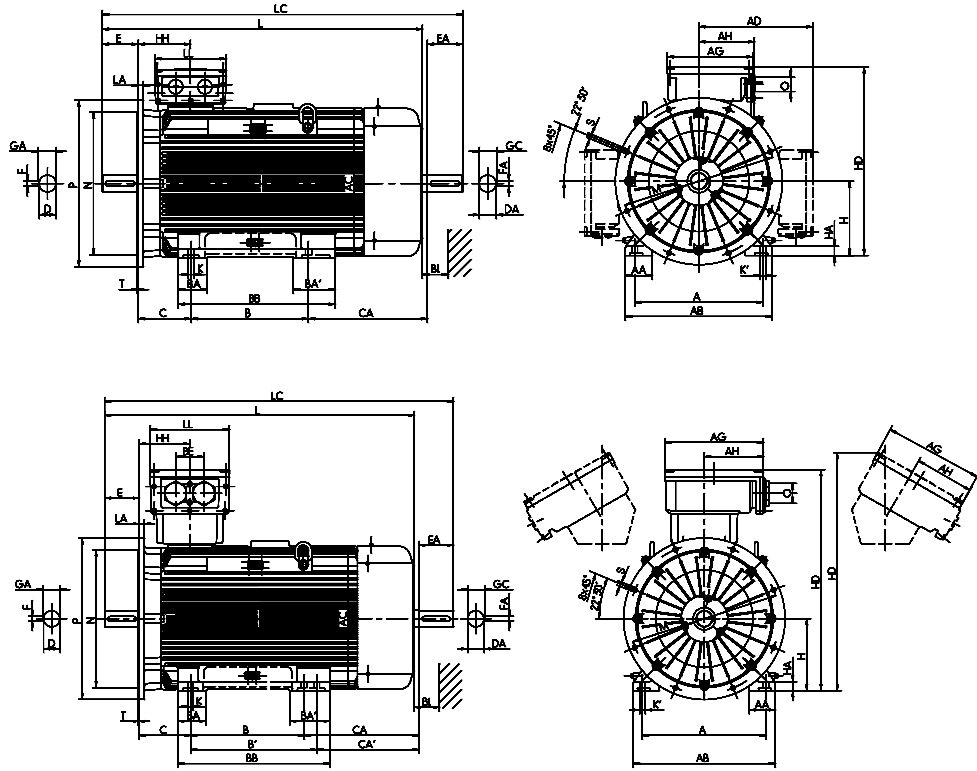

Type designation	GA	GC	H	HA	HD	HD ^{**}	HD	HH	K	K'	L	LC	TB Type	AG	LL	AH	TB Type	AG	LL	AH	O	BI
	t	t1	h	c	p	p	p	A	s	s'	k	k1		x	z	-	VIK	x	z	-	r	BI
IE1-K21R 315 S2	69	69	315	44	731	595	775	211	28	35	1050	1218	200 A	282	242	-	400 A-SB	415	340	265	M63 x 1.5	55
IE1-K21R 315 S4, 6, 8	85	74.5	315	44	731	595	775	211	28	35	1080	1248	200 A	282	242	-	400 A-SB	415	340	265	M63 x 1.5	55
IE1-K21R 315 M2	69	69	315	44	731	595	775	211	28	35	1105	1273	200 A	282	242	-	400 A-SB	415	340	265	M63 x 1.5	55
IE1-K21R 315 M4, 6, 8	85	74.5	315	44	731	595	775	211	28	35	1135	1303	200 A	282	242	-	400 A-SB	415	340	265	M63 x 1.5	55
IE1-K21R 315 MX2	69	69	315	44	731	595	775	211	28	35	1185	1353	200 A	282	242	-	400 A-SB	415	340	265	M63 x 1.5	55
IE1-K21R 315 MX4	85	74.5	315	44	731	595	775	211	28	35	1210	1383	200 A	282	242	-	400 A-SB	415	340	265	M63 x 1.5	55
IE1-K21R 315 MX6, 8	85	74.5	315	44	731	595	775	211	28	35	1135	1303	200 A	282	242	-	400 A-SB	415	340	265	M63 x 1.5	55
IE1-K21R 315 MX10, 12	85	74.5	315	44	731	595	775	211	28	35	1135	1303	200 A	282	242	-	400 A-SB	415	340	265	M63 x 1.5	55
IE1-K21R 315 MY2	69	69	315	44	774	628	996	230	28	35	1270	1448	400 A-SB	415	340	265	630 A	496	390	301	M63 x 1.5	55
IE1-K21R 315 MY4, 6, 8	85	74.5	315	44	774	628	996	230	28	35	1300	1478	400 A-SB	415	340	265	630 A	496	390	301	M63 x 1.5	55
IE1-K21R 315 L2	69	69	315	44	774	628	996	230	28	35	1390	1543	400 A-SB	415	340	265	630 A	496	390	301	M63 x 1.5	55
IE1-K21R 315 L4, 6, 8	85	74.5	315	44	774	628	996	230	28	35	1420	1598	400 A-SB	415	340	265	630 A	496	390	301	M63 x 1.5	55
IE1-K21R 315 LX2	69	69	315	44	796	628	996	230	28	35	1510	1688	400 A-SB	415	340	265	630 A	496	390	301	M63 x 1.5	55
IE1-K21R 315 LX4	85	74.5	315	44	796	628	996	230	28	35	1540	1723	400 A-SB	415	340	265	630 A	496	390	301	M63 x 1.5	55
IE1-K21R 315 LX6, 8	85	74.5	315	44	796	628	996	230	28	35	1420	1598	400 A-SB	415	340	265	630 A	496	390	301	M63 x 1.5	55

** Terminal box left/right

Energy-saving motor for Standard Efficiency IE1
Three-phase motors with squirrel-cage rotor

with surface cooling, type of cooling IC 411, degree of protection IP 55
 Size 355

Type of construction IM V1 [IM 3011]

Flange dimensions, see page 2/109

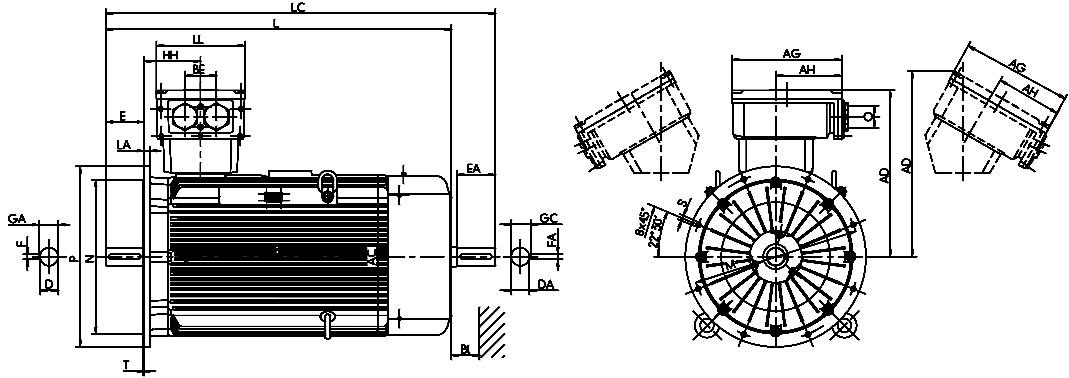

Type designation	Flange size	AC	AD	AD**)	D	DA	DB**)	E	EA	F	FA
		g	g1	g1	d	d1		l	l1	u	u1
IE1-K22R 355 MY2G, M2 G	FF 740	715	736	817	80	80	M20	170	-	22	-
IE1-K22R 355 MY4, 6, 8	FF 740	715	736	817	100	80	M24	210	170	28	22
IE1-K22R 355 M4	FF 740	715	736	817	100	80	M24	210	170	28	22
IE1-K22R 355 M6, 8	FF 740	715	736	817	100	80	M24	210	170	28	22
IE1-K22R 355 MX6, 8	FF 740	715	736	817	100	80	M24	210	170	28	22
IE1-K22R 355 MX2 G	FF 740	715	728	819	80	80	M20	170	-	22	-
IE1-K22R 355 LY2 G, L2 G	FF 740	715	728	819	80	80	M20	170	-	22	-
IE1-K22R 355 MX4	FF 740	715	728	819	100	80	M24	210	170	28	22
IE1-K22R 355 LY, L4	FF 740	715	728	819	100	80	M24	210	170	28	22
IE1-K22R 355 LY6, 8	FF 740	715	728	819	100	80	M24	210	170	28	22

^{*)} Centre holes to DIN 332-DS
^{**)} Terminal box inclined left/right

Type designation	GA	GC	H	HH	L	LC	TB Type	AG	LL	AH	BE	O	BI.
	t	t1	h	A	K	K1	Standard VIK	x	z	-	-	r	BI
IE1-K22R 355 MY2G, M2 G	85	-	355	250	1530	-	KK 630 A	496	390	301	140	M72 x 2	60
IE1-K22R 355 MY4, 6, 8	106	85	355	250	1570	1755	KK 630 A	496	390	301	140	M72 x 2	60
IE1-K22R 355 M4	106	85	355	250	1570	1755	KK 630 A	496	390	301	140	M72 x 2	60
IE1-K22R 355 M6, 8	106	85	355	250	1570	1755	KK 630 A	496	390	301	140	M72 x 2	60
IE1-K22R 355 MX6, 8	106	85	355	327	1690	1875	KK 630 A	496	390	301	140	M72 x 2	60
IE1-K22R 355 MX2 G	85	-	355	327	1650	-	KK 1000 A	615	474	385	200	M72 x 2	60
IE1-K22R 355 LY2G, L2 G	85	-	355	327	1650	-	KK 1000 A	615	474	385	200	M72 x 2	60
IE1-K22R 355 MX4	106	85	355	327	1690	1875	KK 1000 A	615	474	385	200	M72 x 2	60
IE1-K22R 355 LY, L4	106	85	355	327	1690	1875	KK 1000 A	615	474	385	200	M72 x 2	60
IE1-K22R 355 LY6, 8	106	85	355	327	1690	1875	KK 1000 A	615	474	385	200	M72x2	60

Energy-saving motor for Standard Efficiency IE1 Three-phase motors with squirrel-cage rotor

with surface cooling, type of cooling IC 411, degree of protection IP 55
Size 56 to 180

Type of construction IM B34 [IM 2101]

Flange dimensions, see page 2/109

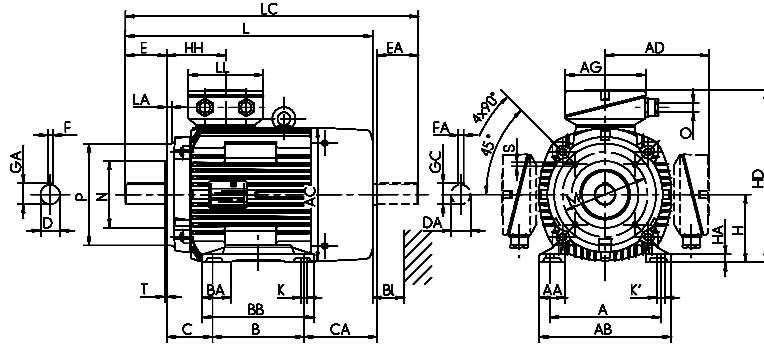

Type designation	Flange size		A	AA	AB	AC	AD	AD	B	BA	BB	C	CA	D	DA	DB ¹⁾	E	EA	F	FA
	small	large	b	n	f	g	g1	g1	a	m	e	w1	w2	d	d1		l	l1	u	u1
	VIK																			
K210 56 K2, 4 U	FT 65	FT 85	90	18	110	-	98		71	-	86	36	28	9	9	M3	20	20	3	3
K21R 56 G2, 4	FT 65	FT 85	90	18	110	109	98		71	-	86	36	52	9	9	M3	20	20	3	3
K21R 63 K2, 4, 6	FT 75	FT 100	100	28	128	109	98		80	-	100	40	39	11	11	M4	23	23	4	4
K21R 63 G2, 4, 6	FT 75	FT 100	100	28	128	109	98		80	-	100	40	39	11	11	M4	23	23	4	4
K21R 71 K2, 4, 6, 8	FT 85	FT 115	112	32	138	124	104		90	-	116	45	43.5	14	14	M5	30	30	5	5
K21R 71 G2, 4, 6, 8	FT 85	FT 115	112	32	138	124	104		90	-	116	45	43.5	14	14	M5	30	30	5	5
IE1-K21R 80 K2, 4, 6, 8	FT 100	FT 130	125	38	168	139	111		100	-	125	50	63	19	19	M6	40	40	6	6
IE1-K21R 80 G2, 4, 6, 8	FT 100	FT 130	125	38	168	139	111		100	-	125	50	63	19	19	M6	40	40	6	6
IE1-K21R 90 S2, 4, 6, 8	FT 115	FT 130	140	40	178	157	119		100	-	130	56	74	24	22	M8	50	50	8	6
IE1-K21R 90 L2, 4, 6, 8	FT 115	FT 130	140	40	178	157	119		125	-	155	56	71	24	22	M8	50	50	8	6
IE1-K21R 100 L2, 4, 6, 8	FT 130	FT 165	160	47	192	177	126		140	-	175	63	73	28	24	M10	60	50	8	8
IE1-K21R 100 LX4, 8	FT 130	FT 165	160	42	193	196	136		140	-	175	63	102	28	28	M10	60	60	8	8
IE1-K21R 112 M2	FT 130	FT 165	190	50	224	196	136		140	-	180	70	95	28	28	M10	60	60	8	8
IE1-K21R 112 M6, 8	FT 130	FT 165	190	50	224	196	136		140	-	180	70	95	28	28	M10	60	60	8	8
IE1-K21R 112 MX2	FT 130	FT 165	190	50	224	196	136		140	-	180	70	129	28	28	M10	60	60	8	8
IE1-K21R 112 M4	FT 130	FT 165	190	50	224	196	136		140	-	180	70	129	28	28	M10	60	60	8	8
IE1-K21R 132 S2, 6, 8T	FT 130	FT 165	216	52	257	196	155		140	-	180	89	129	38	28	M12	80	60	10	8
IE1-K21R 132 S4T	FT 130	FT 165	216	52	257	196	155		140	-	180	89	129	38	28	M12	80	60	10	8
IE1-K21R 132 S2	FT 130	FT 165	216	50	256	217	178	189	140	55	180	89	153	38	32	M12	80	80	10	10
IE1-K21R 132 SX2T	FT 130	FT 165	216	52	257	196	155		140	-	180	89	129	38	28	M12	80	60	10	8
IE1-K21R 132 SX2	FT 130	FT 165	216	50	256	217	178	189	140	55	180	89	173	38	32	M12	80	80	10	10
IE1-K21R 132 S4, 6, 8	FT 130	FT 165	216	50	256	217	178	189	140	55	180	89	153	38	32	M12	80	80	10	10
IE1-K21R 132 M4	FT 165	FT 215	216	50	256	258	199	210	178	55	218	89	138	38	38	M12	80	80	10	10
IE1-K21R 132 MX6	FT 165	FT 215	216	50	256	258	199	210	178	55	218	89	138	38	38	M12	80	80	10	10
IE1-K21R 132 M6, 8	FT 130	FT 165	216	50	256	217	178	189	178	55	218	89	135	38	32	M12	80	80	10	10
IE1-K21R 160 M2	FT 165	FT 215	254	55	296	258	214	214	210	60	257	108	135	42	38	M16	110	80	12	10
IE1-K21R 160 M4, 6, 8	FT 165	FT 215	254	55	296	258	214	214	210	60	257	108	135	42	38	M16	110	80	12	10
IE1-K21R 160 MX8	FT 165	FT 215	254	55	296	258	199	214	210	60	257	108	135	42	38	M16	110	80	12	10
IE1-K21R 160 MX2	FT 215	FT 265	254	55	296	313	242	275	210	60	257	108	148	42	42	M16	110	110	12	12
IE1-K21R 160 L2, 4, 6, 8	FT 215	FT 265	254	55	296	313	242	275	254	60	301	108	142	42	42	M16	110	110	12	12
IE1-K21R 180 M4	FT 265	-	279	62	328	313	242	275	241	65	288	121	142	48	42	M16	110	110	14	12
IE1-K21R 180 L6, 8	FT 265	-	279	62	328	313	242	275	279	65	326	121	104	48	42	M16	110	110	14	12

¹⁾ Centre holes to DIN 332-DS

Energy-saving motor for Standard Efficiency IE1 Three-phase motors with squirrel-cage rotor

with surface cooling, type of cooling IC 411, degree of protection IP 55
Size 56 to 180

Type of construction IM B14 [IM 3601]

Flange dimensions, see page 2/109

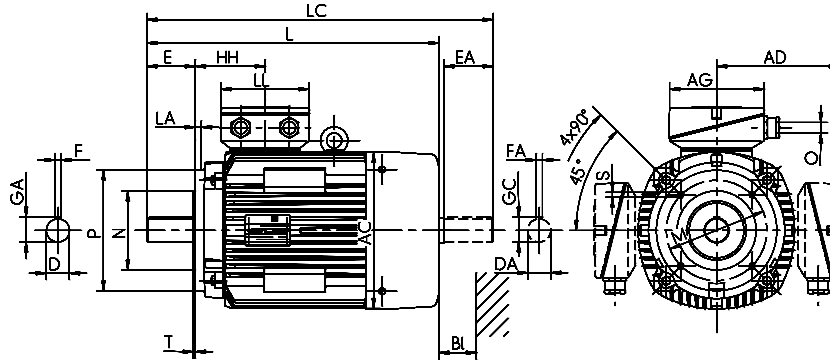

Type designation	GA	GC	H	HA	HD	HD''	HD	HH	K	K'	L	LC	TB Type	AG	LL	TB Type	AG	LL	O	Hole pattern	Bl.	
	t	t1	h	c	p	p	p	A	s	s'	k	k1	-	x	z	VIK	x	z	r		Bl.	
K210 56 K2, 4 U	10.2	10.2	56	7	154	***)		58	6	6	150	175	KA 05	92	92					M20 x 1.5	4L	-
K21R 56 G2, 4	10.2	10.2	56	7	154	***)		58	6	6	176	199	KA 05	92	92					M20 x 1.5	4L	14
K21R 63 K2, 4, 6	12.5	12.5	63	10	161	***)		58	8	8	179	205	KA 05	92	92					M20 x 1.5	4L	14
K21R 63 G2, 4, 6	12.5	12.5	63	10	161	***)		58	8	8	179	205	KA 05	92	92					M20 x 1.5	4L	14
K21R 71 K2, 4, 6, 8	16	16	71	11	175	***)		61	8	8	206	239	KA 05	92	92					M20 x 1.5	4L	14
K21R 71 G2, 4, 6, 8	16	16	71	11	175	***)		61	8	8	206	239	KA 05	92	92					M20 x 1.5	4L	14
IE1-K21R 80 K2, 4, 6, 8	21.5	21.5	80	12	191	***)		67	10	10	249	293	KA 05	92	92					M20 x 1.5	4L	16
IE1-K21R 80 G2, 4, 6, 8	21.5	21.5	80	12	191	***)		67	10	10	249	293	KA 05	92	92					M20 x 1.5	4L	16
IE1-K21R 90 S2, 4, 6, 8	27	24.5	90	14	210	***)		70	10	10	275	330	KA 05	92	92					M25 x 1.5	4L	16
IE1-K21R 90 L2, 4, 6, 8	27	24.5	90	14	210	***)		70	10	10	297	352	KA 05	92	92					M25 x 1.5	4L	16
IE1-K21R 100 L2, 4, 6, 8	31	27	100	15	227	***)		75	12	12	331	386	KA 05	92	92					M25 x 1.5	4L	18
IE1-K21R 100 LX4, 8	31	31	100	13	237	***)		77	12	12	357	425	KA 05	92	92					M25 x 1.5	4L	20
IE1-K21R 112 M2	31	31	112	18	249	***)		77	12	12	357	425	KA 05	92	92					M25 x 1.5	4L	20
IE1-K21R 112 M6, 8	31	31	112	18	249	***)		77	12	12	357	425	KA 05	92	92					M25 x 1.5	4L	20
IE1-K21R 112 MX2	31	31	112	18	249	***)		77	12	12	391	459	KA 05	92	92					M25 x 1.5	4L	20
IE1-K21R 112 M4	31	31	112	18	249	***)		77	12	12	391	459	KA 05	92	92					M25 x 1.5	4L	20
IE1-K21R 132 S2, 6, 8T	41	31	132	18	287	***)		105	12	12	430	498	KA 05-13	104	112					M32 x 1.5	4L	20
IE1-K21R 132 S4T	41	31	132	18	287	***)		105	12	12	460	528	KA 05-13	104	112					M32 x 1.5	4L	20
IE1-K21R 132 S2	41	35	132	16	328	275	310	108	12	12	459	542	25 A	156	145	25 AV	143	134		M32 x 1.5	4L	35
IE1-K21R 132 SX2T	41	31	132	18	287	***)		105	12	12	460	528	KA 05-13	104	112					M32 x 1.5	4L	20
IE1-K21R 132 SX2	41	35	132	16	328	275	310	108	12	12	479	562	25 A	156	145	25 AV	143	134		M32 x 1.5	4L	35
IE1-K21R 132 S4, 6, 8	41	35	132	16	328	275	310	108	12	12	459	542	25 A	156	145	25 AV	143	134		M32 x 1.5	4L	35
IE1-K21R 132 M4	41	41	132	16	349	297	331	114	12	12	481	565	25 A	156	145	25 AV	143	134		M32 x 1.5	4L	35
IE1-K21R 132 MX6	41	41	132	16	349	297	331	114	12	12	481	565	25 A	156	145	25 AV	143	134		M32 x 1.5	4L	35
IE1-K21R 132 M6, 8	41	35	132	16	328	275	310	108	12	12	479	562	25 A	156	145	25 AV	143	134		M32 x 1.5	4L	35
IE1-K21R 160 M2	45	41	160	18	389	322	370	114	15	15	559	643	63 A	193	167	25 AV	143	134		M32 x 1.5	4L	35
IE1-K21R 160 M4, 6, 8	45	41	160	18	389	322	370	114	15	15	559	643	63 A	193	167	25 AV	143	134		M32 x 1.5	4L	35
IE1-K21R 160 MX8	45	41	160	18	389	322	370	114	15	15	559	643	63 A	193	167	25 AV	143	134		M32 x 1.5	4L	35
IE1-K21R 160 MX2	45	45	160	18	417	351	435	138	15	20	571	686	63 A	193	167	100/63 AV	223	214		M40 x 1.5	4L	35
IE1-K21R 160 L2, 4, 6, 8	45	45	160	18	417	351	435	138	15	20	609	724	63 A	193	167	100/63 AV	223	214		M40 x 1.5	4L	35
IE1-K21R 180 M4	51.5	45	180	20	417	351	459	138	15	20	609	724	63 A	193	167	100/63 AV	223	214		M40 x 1.5	4L	35
IE1-K21R 180 L6, 8	51.5	45	180	20	417	364	459	138	15	20	609	724	63 A	193	167	100/63 AV	223	214		M40 x 1.5	4L	35

**) Terminal box left/right
***) upon request

Energy-saving motor for Standard Efficiency IE1
Three-phase motors with squirrel-cage rotor

with surface cooling, type of cooling IC 411, degree of protection IP 55
 Size 56 to 280

Type of construction IM B5 [IM 3001]

Type of construction IM V1 [IM 3011]

Flange dimensions, see page 2/109

Type designation	Flange size	AC	AD	AD	D	DA	DB ¹⁾	E	EA	F	FA	GA	GC
	g	g1	g1	VIK	d	d1		l	l1	u	u1	t	t1
K210 56 K2, 4 U	FF100	-	98		9	9	M3	20	20	3	3	10.2	10.2
K21R 56 G2, 4	FF100	109	98		9	9	M3	20	20	3	3	10.2	10.2
K21R 63 K2, 4, 6	FF115	109	98		11	11	M4	23	23	4	4	12.5	12.5
K21R 63 G2, 4, 6	FF115	109	98		11	11	M4	23	23	4	4	12.5	12.5
K21R 71 K2, 4, 6, 8	FF130	124	104		14	14	M5	30	30	5	5	16	16
K21R 71 G2, 4, 6, 8	FF130	124	104		14	14	M5	30	30	5	5	16	16
IE1-K21R 80 K2, 4, 6, 8	FF 165	139	111		19	19	M6	40	40	6	6	21.5	21.5
IE1-K21R 80 G2, 4, 6, 8	FF 165	139	111		19	19	M6	40	40	6	6	21.5	21.5
IE1-K21R 90 S2, 4, 6, 8	FF 165	157	119		24	22	M8	50	50	8	6	27	24.5
IE1-K21R 90 L2, 4, 6, 8	FF 165	157	119		24	22	M8	50	50	8	6	27	24.5
IE1-K21R 100 L2, 4, 6, 8	FF 215	177	126		28	24	M10	60	50	8	8	31	27
IE1-K21R 100 LX4, 8	FF 215	196	136		28	28	M10	60	60	8	8	31	31
IE1-K21R 112 M2	FF 215	196	136		28	28	M10	60	60	8	8	31	31
IE1-K21R 112 M6, 8	FF 215	196	136		28	28	M10	60	60	8	8	31	31
IE1-K21R 112 MX2	FF 215	196	136		28	28	M10	60	60	8	8	31	31
IE1-K21R 112 M4	FF 215	196	136		28	28	M10	60	60	8	8	31	31
IE1-K21R 132 S2, 6, 8T	FF265	196	155		38	28	M12	80	60	10	8	41	31
IE1-K21R 132 S4T	FF265	196	155		38	28	M12	80	60	10	8	41	31
IE1-K21R 132 S2	FF265	217	178	189	38	32	M12	80	80	10	10	41	35
IE1-K21R 132 SX2T	FF265	196	155		38	28	M12	80	60	10	8	41	31
IE1-K21R 132 SX2	FF265	217	178	189	38	32	M12	80	80	10	10	41	35
IE1-K21R 132 S4, 6, 8	FF265	217	178	189	38	32	M12	80	80	10	10	41	35
IE1-K21R 132 M4	FF265	258	199	210	38	38	M12	80	80	10	10	41	41
IE1-K21R 132 MX6	FF265	258	199	210	38	38	M12	80	80	10	10	41	41
IE1-K21R 132 M6, 8	FF265	217	178	189	38	32	M12	80	80	10	10	41	35
IE1-K21R 160 M2	FF300	258	214	214	42	38	M16	110	80	12	10	45	41
IE1-K21R 160 M4, 6, 8	FF300	258	214	214	42	38	M16	110	80	12	10	45	41
IE1-K21R 160 MX8	FF300	258	199	214	42	38	M16	110	80	12	10	45	41
IE1-K21R 160 MX2	FF300	313	242	275	42	42	M16	110	110	12	12	45	45
IE1-K21R 160 L2, 4, 6, 8	FF300	313	242	275	42	42	M16	110	110	12	12	45	45
IE1-K21R 180 M2	FF300	351	261	294	48	48	M16	110	110	14	14	51.5	51.5
IE1-K21R 180 M4	FF300	313	242	275	48	42	M16	110	110	14	12	51.5	45
IE1-K21R 180 L4	FF300	351	261	294	48	48	M16	110	110	14	14	51.5	51.5
IE1-K21R 180 L6, 8	FF300	313	242	275	48	42	M16	110	110	14	12	51.5	45
IE1-K21R 200 L2, 4, 6, 8	FF 350	351	261	294	55	48	M20	110	110	16	14	59	51.5
IE1-K21R 200 LX6	FF 350	351	261	294	55	48	M20	110	110	16	14	59	51.5
IE1-K21R 200 LX2	FF 350	390	300	378	55	55	M20	110	110	16	16	59	59
IE1-K21R 225 S4, 8	FF 400	390	300	378	60	55	M20	140	110	18	16	64	59
IE1-K21R 225 M2	FF 400	390	300	378	55	55	M20	110	110	16	16	59	59
IE1-K21R 225 M4	FF 400	390	300	378	60	55	M20	140	110	18	16	64	59
IE1-K21R 225 M6, 8	FF 400	390	300	378	60	55	M20	140	110	18	16	64	59
IE1-K21R 250 M2	FF 500	440	358	406	60	55	M20	140	110	18	16	64	59
IE1-K21R 250 M4, 6, 8	FF 500	440	358	406	65	55	M20	140	110	18	16	69	59
IE1-K21R 280 S2	FF 500	490	386	399	65	65	M20	140	140	18	18	69	69
IE1-K21R 280 S4, 6, 8	FF 500	490	386	399	75	65	M20	140	140	20	18	79.5	69
IE1-K21R 280 M2	FF 500	490	386	399	65	65	M20	140	140	18	18	69	69
IE1-K21R 280 M4, 6, 8	FF 500	490	386	399	75	65	M20	140	140	20	18	79.5	69

¹⁾ Centre holes to DIN 332-DS

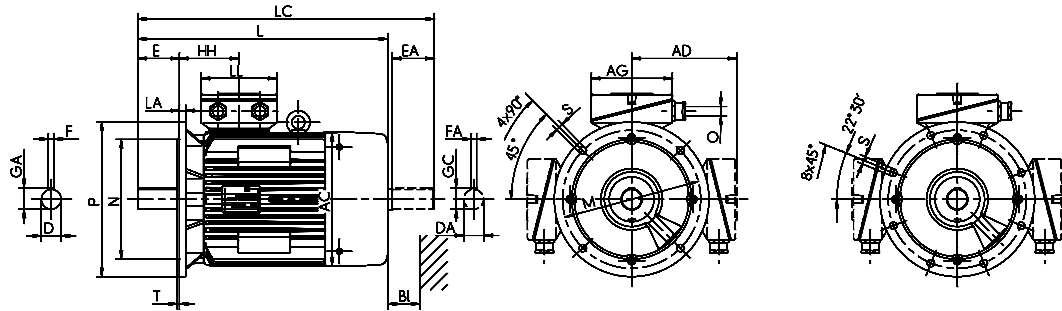

Type designation	H	HH	L	LC	TB Type	AG	LL	TB Type	AG	LL	O	Hole pattern	Bl.
	h	A	k	k1				VIK					Bl
K210 56 K2, 4 U	56	81	173	197	KA 05	92	92				M20 x 1.5	4L	14
K21R 56 G2, 4	56	81	199	223	KA 05	92	92				M20 x 1.5	4L	14
K21R 63 K2, 4, 6	63	58	179	205	KA 05	92	92				M20 x 1.5	4L	14
K21R 63 G2, 4, 6	63	58	179	205	KA 05	92	92				M20 x 1.5	4L	14
K21R 71 K2, 4, 6, 8	71	61	206	239	KA 05	92	92				M20 x 1.5	4L	14
K21R 71 G2, 4, 6, 8	71	61	206	239	KA 05	92	92				M20 x 1.5	4L	14
IE1-K21R 80 K2, 4, 6, 8	80	67	249	293	KA 05	92	92				M20 x 1.5	4L	16
IE1-K21R 80 G2, 4, 6, 8	80	67	249	293	KA 05	92	92				M20 x 1.5	4L	16
IE1-K21R 90 S2, 4, 6, 8	90	70	275	330	KA 05	92	92				M25 x 1.5	4L	16
IE1-K21R 90 L2, 4, 6, 8	90	70	297	352	KA 05	92	92				M25 x 1.5	4L	16
IE1-K21R 100 L2, 4, 6, 8	100	75	331	386	KA 05	92	92				M25 x 1.5	4L	18
IE1-K21R 100 LX4, 8	100	77	357	425	KA 05	92	92				M25 x 1.5	4L	20
IE1-K21R 112 M2	112	77	357	425	KA 05	92	92				M25 x 1.5	4L	20
IE1-K21R 112 M6, 8	112	77	391	425	KA 05	92	92				M25 x 1.5	4L	20
IE1-K21R 112 MX2	112	77	391	459	KA 05	92	92				M25 x 1.5	4L	20
IE1-K21R 112 M4	112	77	391	459	KA 05	92	92				M25 x 1.5	4L	20
IE1-K21R 132 S2, 6, 8T	132	105	430	498	KA 05-13	104	112				M32 x 1.5	4L	20
IE1-K21R 132 S4T	132	105	460	528	KA 05-13	104	112				M32 x 1.5	4L	20
IE1-K21R 132 S2	132	108	459	542	25 A	156	145	25 AV	143	134	M32 x 1.5	4L	35
IE1-K21R 132 SX2T	132	105	460	528	KA 05-13	104	112				M32 x 1.5	4L	20
IE1-K21R 132 SX2	132	108	479	562	25 A	156	145	25 AV	143	134	M32 x 1.5	4L	35
IE1-K21R 132 S4, 6, 8	132	108	459	542	25 A	156	145	25 AV	143	134	M32 x 1.5	4L	35
IE1-K21R 132 M4	132	114	481	565	25 A	156	145	25 AV	143	134	M32 x 1.5	4L	35
IE1-K21R 132 MX6	132	114	481	565	25 A	156	145	25 AV	143	134	M32 x 1.5	4L	35
IE1-K21R 132 M6, 8	132	108	479	562	25 A	156	145	25 AV	143	134	M32 x 1.5	4L	35
IE1-K21R 160 M2	160	114	559	643	25 A	156	145	25 AV	143	134	M32 x 1.5	4L	35
IE1-K21R 160 M4, 6, 8	160	114	559	643	25 A	156	145	25 AV	143	134	M32 x 1.5	4L	35
IE1-K21R 160 MX8	160	114	559	643	25 A	156	145	25 AV	143	134	M32 x 1.5	4L	35
IE1-K21R 160 MX2	160	138	571	686	63 A	193	167	100/63 AV	223	214	M40 x 1.5	4L	35
IE1-K21R 160 L2, 4, 6, 8	160	138	609	724	63 A	193	167	100/63 AV	223	214	M40 x 1.5	4L	35
IE1-K21R 180 M2	180	147	635	751	63 A	193	167	100/63 AV	223	214	M40 x 1.5	4L	35
IE1-K21R 180 M4	180	138	609	724	63 A	193	167	100/63 AV	223	214	M40 x 1.5	4L	35
IE1-K21R 180 L4	180	147	680	796	63 A	193	167	100/63 AV	223	214	M40 x 1.5	4L	35
IE1-K21R 180 L6, 8	180	138	609	724	63 A	193	167	100/63 AV	223	214	M40 x 1.5	4L	35
IE1-K21R 200 L2, 4, 6, 8	200	147	680	796	63 A	193	167	100/63 AV	223	214	M40 x 1.5	4L	35
IE1-K21R 200 LX6	200	147	680	796	63 A	193	167	100/63 AV	223	214	M40 x 1.5	4L	35
IE1-K21R 200 LX2	200	168	727	851	100 A	213	207	200 A-SB	335	270	M50 x 1.5	4L	35
IE1-K21R 225 S4, 8	225	168	757	881	100 A	213	207	200 A-SB	335	270	M50 x 1.5	8L	40
IE1-K21R 225 M2	225	168	767	891	100 A	213	207	200 A-SB	335	270	M50 x 1.5	8L	40
IE1-K21R 225 M4	225	168	797	921	100 A	213	207	200 A-SB	335	270	M50 x 1.5	8L	40
IE1-K21R 225 M6, 8	225	168	757	881	100 A	213	207	200 A-SB	335	270	M50 x 1.5	8L	40
IE1-K21R 250 M2	250	177	862	977	200 A	282	242	200 A-SB	335	270	M63 x 1.5	8L	45
IE1-K21R 250 M4, 6, 8	250	177	862	977	200 A	282	242	200 A-SB	335	270	M63 x 1.5	8L	45
IE1-K21R 280 S2	280	206	924	1072	200 A	282	242	200 A-SB	335	270	M63 x 1.5	8L	50
IE1-K21R 280 S4, 6, 8	280	206	924	1072	200 A	282	242	200 A-SB	335	270	M63 x 1.5	8L	50
IE1-K21R 280 M2	280	206	970	1118	200 A	282	242	200 A-SB	335	270	M63 x 1.5	8L	50
IE1-K21R 280 M4, 6, 8	280	206	970	1118	200 A	282	242	200 A-SB	335	270	M63 x 1.5	8L	50

**Energy-saving motor for Standard Efficiency IE1
Three-phase motors with squirrel-cage rotor**

with surface cooling, type of cooling IC 411, degree of protection IP 55
Size 315

Type of construction IM B5 [IM 3001] to Size 315 MY

Type of construction IM V1 [IM 3011]

Flange dimensions, see page 2/109

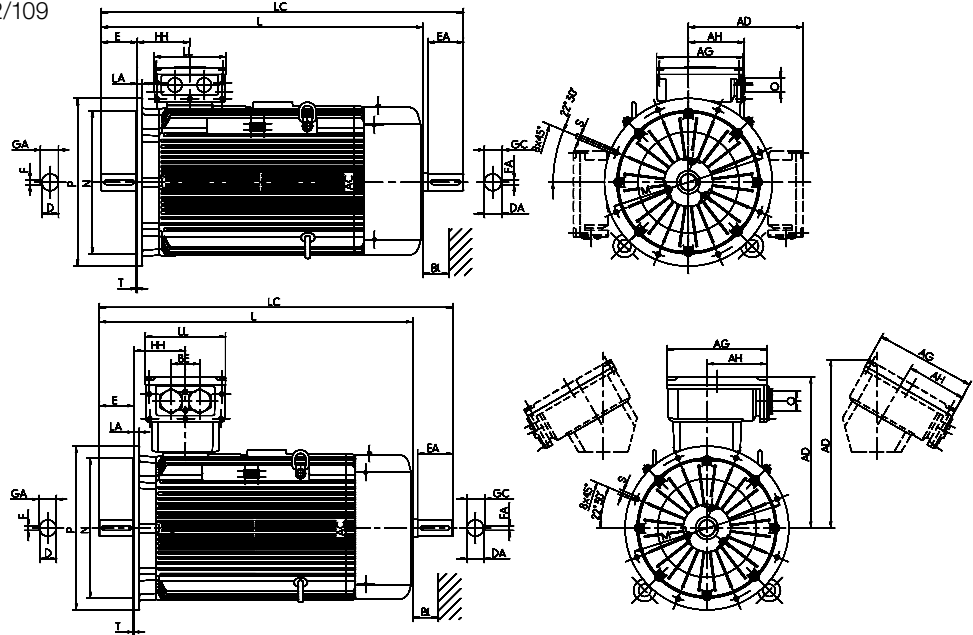

Type designation	Flange size	AC	AD	AD	D	DA	DB ¹⁾	E	EA	F	FA	GA	GC
		g	g1	g1	d	d1		l	l1	u	u1	t	t1
IE1-K21R 315 S2	FF 600	550	416	460	65	65	M20	140	140	18	18	69	69
IE1-K21R 315 S4, 6, 8	FF 600	550	416	460	80	70	M20	170	140	22	20	85	74.5
IE1-K21R 315 M2	FF 600	550	416	460	65	65	M20	140	140	18	18	69	69
IE1-K21R 315 M4, 6, 8	FF 600	550	416	460	80	70	M20	170	140	22	20	85	74.5
IE1-K21R 315 MX2	FF 600	550	416	460	65	65	M20	140	140	18	18	69	69
IE1-K21R 315 MX4	FF 600	550	416	460	80	70	M20	170	140	22	20	85	74.5
IE1-K21R 315 MX6, 8	FF 600	550	416	460	80	70	M20	170	140	22	20	85	74.5
IE1-K21R 315 MX10, 12	FF 600	550	416	460	80	70	M20	170	140	22	20	85	74.5
IE1-K21R 315 MY2	FF 600	610	498	681	65	65	M20	140	140	18	18	69	69
IE1-K21R 315 MY4, 6, 8	FF 600	610	498	681	80	70	M20	170	140	22	20	85	74.5
IE1-K21R 315 L2	FF 600	610	498	681	65	65	M20	140	140	18	18	69	69
IE1-K21R 315 L4, 6, 8	FF 600	610	498	681	80	70	M20	170	140	22	20	85	74.5
IE1-K21R 315 LX2	FF 600	610	481	681	65	65	M20	140	140	18	18	69	69
IE1-K21R 315 LX4	FF 600	610	481	681	80	70	M20	170	140	22	20	85	74.5
IE1-K21R 315 LX6, 8	FF 600	610	498	681	80	70	M20	170	140	22	20	85	74.5

Type designation	H	HH	L	LC	TB Type	AG	LL	AH	TB Type	AG	LL	AH	O	BI.
	h	A	k	k1	x	z	-	VIK	x	z	-	r	BI	
IE1-K21R 315 S2	315	211	1050	1218	200 A	282	242	-	400 A-SB	415	340	265	M63 x 1.5	55
IE1-K21R 315 S4, 6, 8	315	211	1080	1248	200 A	282	242	-	400 A-SB	415	340	265	M63 x 1.5	55
IE1-K21R 315 M2	315	211	1105	1273	200 A	282	242	-	400 A-SB	415	340	265	M63 x 1.5	55
IE1-K21R 315 M4, 6, 8	315	211	1135	1303	200 A	282	242	-	400 A-SB	415	340	265	M63 x 1.5	55
IE1-K21R 315 MX2	315	211	1185	1353	200 A	282	242	-	400 A-SB	415	340	265	M63 x 1.5	55
IE1-K21R 315 MX4	315	211	1215	1383	200 A	282	242	-	400 A-SB	415	340	265	M63 x 1.5	55
IE1-K21R 315 MX6, 8	315	211	1135	1303	200 A	282	242	-	400 A-SB	415	340	265	M63 x 1.5	55
IE1-K21R 315 MX10, 12	315	211	1135	1303	200 A	282	242	-	400 A-SB	415	340	265	M63 x 1.5	55
IE1-K21R 315 MY2	315	230	1270	1448	400 A-SB	415	340	265	630 A	496	390	301	M63 x 1.5	55
IE1-K21R 315 MY4, 6, 8	315	230	1300	1478	400 A-SB	415	340	265	630 A	496	390	301	M63 x 1.5	55
IE1-K21R 315 L2	315	230	1390	1543	400 A-SB	415	340	265	630 A	496	390	301	M63 x 1.5	55
IE1-K21R 315 L4, 6, 8	315	230	1420	1598	400 A-SB	415	340	265	630 A	496	390	301	M63 x 1.5	55
IE1-K21R 315 LX2	315	230	1510	1688	400 A-SB	415	340	265	630 A	496	390	301	M63 x 1.5	55
IE1-K21R 315 LX4	315	230	1540	1723	400 A-SB	415	340	265	630 A	496	390	301	M63 x 1.5	55
IE1-K21R 315 LX6, 8	315	230	1420	1598	400 A-SB	415	340	265	630 A	496	390	301	M63 x 1.5	55

¹⁾ Centre holes to DIN 332-DS

Energy-saving motor for Standard Efficiency IE1 Three-phase motors with squirrel-cage rotor

with surface cooling, type of cooling IC 411, degree of protection IP 55
Size 355

Type of construction IM B3 [IM 1001]

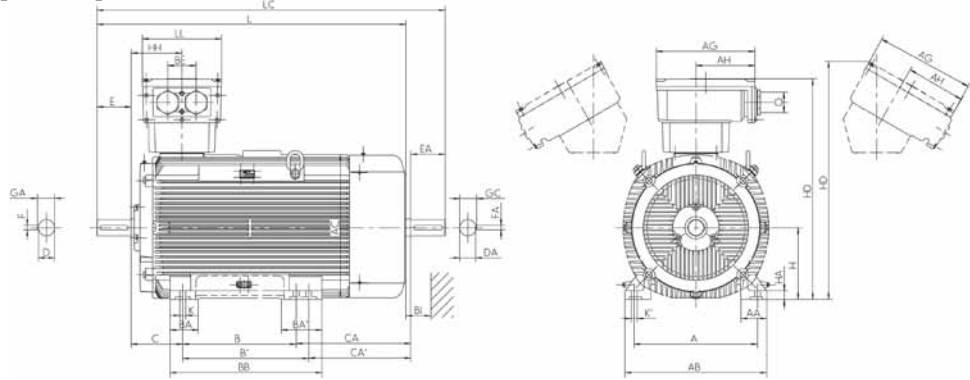

Type of construction IM B35 [IM 2001]

Flange dimensions, see page 2/109

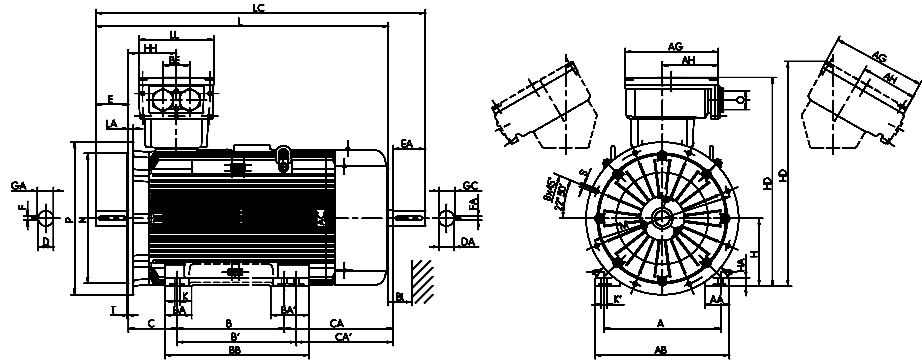

Type designation	Flange size	A	AA	AB	AC	B	BA	BA'	BB	C	CA	D	DA	DB ¹⁾	E	EA	F	FA
	b	n	f	g	a	m	m1	e	w1	w2	d	d1	l	l1	u	u1		
IE1-K22R 355 MY2G, M2G	FF 740	610	130	700	715	560	140	200	750	254	561	80	80	M20	170	-	22	-
IE1-K22R 355 MY4, 6, 8	FF 740	610	130	700	715	560	140	200	750	254	561	100	80	M24	210	170	28	22
IE1-K22R 355 M4	FF 740	610	130	700	715	560	140	200	750	254	561	100	80	M24	210	170	28	22
IE1-K22R 355 M6, 8	FF 740	610	130	700	715	560	140	200	750	254	561	100	80	M24	210	170	28	22
IE1-K22R 355 MX6, 8	FF 740	610	130	700	715	560	140	200	750	254	681	100	80	M24	210	170	28	22
IE1-K22R 355 MX2G	FF 740	610	130	700	715	560	140	200	750	254	681	80	80	M20	170	-	22	-
IE1-K22R 355 LY2G, L2G	FF 740	610	130	700	715	630	140	200	750	254	611	80	80	M20	170	-	22	-
IE1-K22R 355 MX4	FF 740	610	130	700	715	560	140	200	750	254	681	100	80	M24	210	170	28	22
IE1-K22R 355 LY4, L4	FF 740	610	130	700	715	630	140	200	750	254	611	100	80	M24	210	170	28	22
IE1-K22R 355 LY6, 8	FF 740	610	130	700	715	630	140	200	750	254	611	100	80	M24	210	170	28	22

Type designation	GA	GC	H	HA	HD	HD ²⁾	HH	K	K'	L	LC	TB Type	AG	LL	AH	BE	O	BI	
	t	t1	h	c	p	p	A	s	s'	k	k1	Standard	VIK	x	z	-	-	r	BI
IE1-K22R 355 MY2G, M2G	85	-	355	44	1091	1172	250	28	35	1530	-	KK 630 A	496	390	301	140	M72 x 2	60	
IE1-K22R 355 MY4, 6, 8	106	85	355	44	1091	1172	250	28	35	1570	1755	KK 630 A	496	390	301	140	M72 x 2	60	
IE1-K22R 355 M4	106	85	355	44	1091	1172	250	28	35	1570	1755	KK 630 A	496	390	301	140	M72 x 2	60	
IE1-K22R 355 M6, 8	106	85	355	44	1091	1172	250	28	35	1570	1755	KK 630 A	496	390	301	140	M72 x 2	60	
IE1-K22R 355 MX6, 8	106	85	355	44	1091	1172	327	28	35	1690	1875	KK 630 A	496	390	301	140	M72 x 2	60	
IE1-K22R 355 MX2G	85	-	355	44	1083	1174	327	28	35	1650	-	KK 1000 A	615	474	385	200	M72 x 2	60	
IE1-K22R 355 LY2G, L2G	85	-	355	44	1083	1174	327	28	35	1650	-	KK 1000 A	615	474	385	200	M72 x 2	60	
IE1-K22R 355 MX4	106	85	355	44	1083	1174	327	28	35	1690	1875	KK 1000 A	615	474	385	200	M72 x 2	60	
IE1-K22R 355 LY4, L4	106	85	355	44	1083	1174	327	28	35	1690	1875	KK 1000 A	615	474	385	200	M72 x 2	60	
IE1-K22R 355 LY6, 8	106	85	355	44	1083	1174	327	28	35	1690	1875	KK 1000 A	615	474	385	200	M72 x 2	60	

¹⁾ Centre holes to DIN 332-DS
²⁾ Terminal box inclined left/right



VEM  MOTOR

Transnorm motors

Contents

Product description _____	3/2
Overview of technical data _____	3/4
Motor selection data	
W4.R series for Premium Efficiency IE3 _____	3/5
Bearings _____	3/6
Terminal boxes _____	3/7
Dimensions _____	3/9

Product description

Electric machines from VEM are appreciated by millions of users worldwide, and the name VEM is respected as a seal of quality. Large and special machines, as well as standard motors and special drives, are operating reliably in all branches of industry. Plants of all kinds are equipped with motors, generators and drive solutions for the full range of voltages. These products have been demonstrating their strengths for decades, even when exposed to some of the most extreme operating conditions – whether the dust and heat of a rolling mill, explosive atmospheres in the chemical industry, or damp, salt-laden air on the deck of a ship. Our company can look back over more than 60 years of tradition and experience in the manufacturing of electric machines.

Technical features

- Efficiency class IE3
- Types of construction IM B3, IM B35 and IM V1 to IEC
- Degree of protection IP 55; optionally IP 56 or IP 65
- Robust, one-piece die-cast rotor
- Winding compliant with thermal class 155, optionally 180, vacuum-impregnated
- Optimised ventilation system with internal and external cooling from size 355 MX
- Relubrication facility with grease supply regulator
- Temperature monitoring with PTC thermistor (low voltage) or PT 100 (high voltage version)
- Generously dimensioned terminal box
- Incorporates an RFID transponder as standard (memory motor)
- Environment-friendly finish using water-based paint

Benefits

- Energy-efficient design compliant with efficiency class IE3
- Direct access to technical data and maintenance history via an RFID transponder
- Robust grey-cast iron housing and end shields
- Low-vibration design
- Compact design with smallest possible installation volume
- High electrical strength for mains and converter-fed operation
- Quiet running
- Paint finishes for climate classes “Moderate” and “Worldwide” to IEC 721-2-1
- Modern modular system
- State-of-the-art manufacturing methods ensure high operational reliability

Diverse applications

The range of applications for motors of the latest VEM generation is practically unlimited. They are ideal as drives to transport liquid media or compress gases, but no less suitable for use in cement works, rolling mills or chemical plants. In conjunction with frequency converters, the motors enable operators to implement tailored process control. The optimised winding design permits use in variable-speed drive systems. A special mica-based winding system is available for converter-fed operation with converter output voltages up to 690 V. This system is designed for stresses in accordance with Curve B, IEC TS 60034-25.

With the new energy-efficient transnorm motor series W4.R, VEM has extended its low-voltage asynchronous motor range up to 710 kW. In addition, this design series is also available in a high-voltage version for the output range up to 750 kW.

The motor efficiency meets the requirements of class IE3 “Premium Efficiency” to IEC/EN 60034-30-1. Further development of the long-proven VEM design series, with corresponding expansion of the output range, addresses the increasing importance of energy efficiency and the ever stricter demands relating to environment protection.

Our motors comply with all relevant national and international regulations. All development, engineering, manufacturing and testing activities are governed by the stipulations of DIN ISO 9001 and are certified by DNV GL. As an option, versions for use in potentially explosive atmospheres (Zone 2 and Zone 22) can also be supplied. The motors meet the requirements of all applicable EU standards. Manufactured in Germany, they reflect an important element of our quality philosophy.

Design details

The new transorm motors W42R/W52R break with the principle of exclusively rib cooling and incorporate an additional internal cooling system. An innovative ventilation system with a special twin-circuit internal fan provides for optimum cooling of the rotor, stator core and winding overhangs.

The robust motor housings, which are cast with additional ribs in the cooling channels using the latest foundry technologies, support this effect in conjunction with a new die-cast rotor concept and guarantee high efficiency ratings from an extremely compact design.

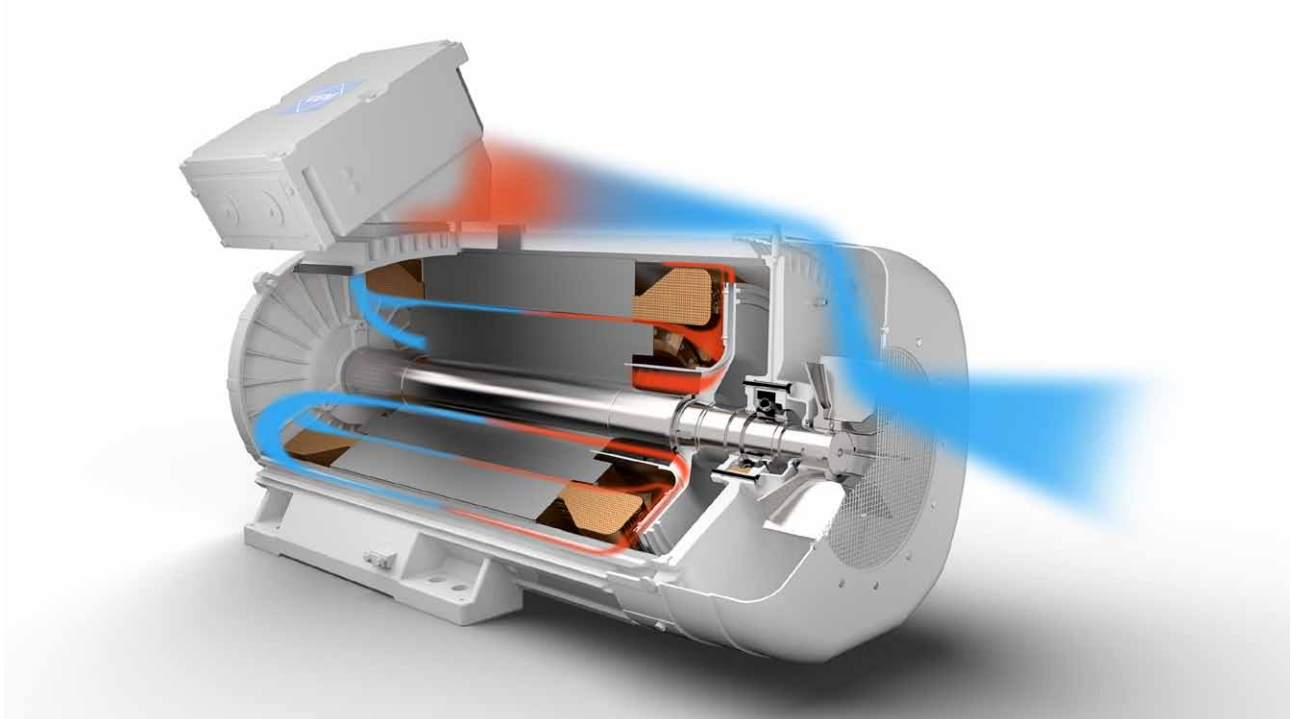

Sectional drawing Motor design

Memory design

The RFID technology has already been in successful use at VEM motors for a number of years. Important data describing the drive system are saved on an RFID tag, which is then attached permanently to the motor.

This additional functionality – referred to as “memory design” – is a standard feature for motors from size 400 (RFID system iID®2000, 13.56 MHz, based on ISO 15693). On smaller motors up to and including size 355, it is available

as an option. The memory chip of the transponder (tag) stores selected rating plate and motor data, along with additional technical information on any mounted accessories, selected spare parts, motor maintenance requirements, and possibly even customer or user data, where appropriate. It is furthermore possible to keep a regular log of all maintenance work performed.

Overview of technical data

The most important technical data are summarised in the following table. Further information can be taken from the catalogue section "Technical explanations".

Product group	Squirrel-cage rotor, IEC/DIN
Rated output	132 to 710 kW 2, 4, 6 and 8 poles
Sizes	355 to 400
Efficiency classification/ efficiency determination	IEC/EN 60034-30-1 / IEC/EN 60034-2-1, residual loss method
Housing material	Grey cast iron with cast-on motor feet
Rated torque	1000 to 5768 Nm
Method of connection	Single-speed motors are designed in star-delta configuration as standard.
Stator winding insulation	Thermal class 155, optional 155 [F(B)], 180 to IEC/EN 60034-1
Degree of protection	IP 55 to IEC/EN 60034-5, optionally IP 56 and higher
Type of cooling	Self-ventilated, IC 411 (series W4.R) Forced ventilation, IC 416 (series W4.F) Non-ventilated, IC 410 (series W4.O) to IEC/EN 60034-6
Coolant temperature/ installation altitude	Standard -20 °C to +40 °C, optional -40 °C to +60 °C Altitude 1000 m above sea level
Rated voltage	Standard voltages to EN 60038 50 Hz: 400 V, 500 V, 690 V 60 Hz: 460 V, 480 V, 600 V Voltage ranges A and B to IEC/EN 60034-1
Duty types	S1, continuous duty, Short-time duty S2, 10/30/60 min Duty type S3/S6, 25/40/60% c.d.f.
Type of construction	IM B3, IM B35, IM V1 and derived types to DIN EN 60034-7
Paint finish	Normal finish "Moderate", colour RAL 7031, blue-grey Special finish "Worldwide", colour RAL 7031, blue-grey
Vibration severity grade	Grade "A" as standard for machines with no special vibration requirements
Shaft ends	to DIN 748 (IEC 60072), balanced with half-key
Transponder	RFID System iID@2000 (13.56 MHz based on ISO 15693), standard from size 400, available as option for sizes 315 to 355
Limit speeds	Please refer to the section of "Limit speeds" in catalogue section "Motors for converter-fed operation", Chapter 4.
Bearing design	Please refer to the tables of "Bearing design data".
Motor mass	Please refer to the "Technical selection lists".
Terminal boxes	Please refer to the section "Terminal boxes".
Documentation	An operating and maintenance manual, a terminal plan and a safety data sheet are supplied with each motor.
Tolerances	Please refer to the section "Tolerances" in catalogue section "Introduction", Chapter 1.
Options	Please refer to the section "Overview of modifications" in catalogue section "Introduction", Chapter 1.

Motor selection data

Transnorm motors, Premium Efficiency IE3 Three phase-motors with squirrel-cage rotor

with surface cooling, duty type S1, continuous duty
thermal class 155, degree of protection IP 55
Efficiency determination according to IEC/EN 60034-2-1

Motor selection data													Design point 400 V, 50 Hz				
Type	U _B V	f _B Hz	P _B kW	M _B Nm	n _B rpm	η _B to IEC/IEC 60034-2-1			cos φ _B -	I _B A	I _A /I _B -	M _A /M _B -	M _V /M _B -	M _K /M _B -	kgm ²	kg	
						100 %	75 %	50 %									
Synchronous speed 3000 rpm – 2-pole version																	
IE3-W41R 355 MY2G	400	50	315	1006	2990	96.0	96.0	95.5	0.90	526	8.5	1.4	1.0	2.7	4.1	1900	
IE3-W41R 355 M2G	400	50	355	1136	2985	96.0	96.0	96.0	0.92	580	7.7	1.3	1.0	2.6	4.2	2000	
IE3-W42R 355 MX2G	400	50	400	1278	2988	96.0	96.0	96.0	0.92	654	8.5	1.8	1.1	2.5	5.5	2275	
IE3-W42R 355 L2G	400	50	500	1597	2990	96.2	96.2	96.2	0.90	834	11.0	2.2	1.4	3.2	7.1	2450	
IE3-W42R 400 M2G	400	50	560	1786	2995	96.0	96.0	95.5	0.83	1014	9.0	2.8		3.0	8.44	3000	
IE3-W42R 400 MX2G	400	50	630	2011	2992	96.0	96.0	95.5	0.91	1041	9.5	2.5		2.7	9.41	3200	
IE3-W42R 400 L2G	400	50	710	2271	2985	96.0	96.0	95.5	0.9	1186	7.7	2.2	1.1	2.8	10.41	3400	
Synchronous speed 1500 rpm – 4-pole version																	
IE3-W41R 355 MY4	400	50	315	2016	1492	96.0	96.0	95.5	0.86	551	7.0	1.0	0.8	2.3	5.6	1950	
IE3-W41R 355 M4	400	50	355	2271	1493	96.2	96.2	95.5	0.87	612	8.1	1.3	1.0	2.7	7.9	2150	
IE3-W42R 355 MX4	400	50	400	2564	1490	96.2	96.2	96.2	0.84	714	8.2	1.7	1.4	2.4	9.5	2410	
IE3-W42R 355 L4	400	50	500	3204	1490	96.4	96.4	96.0	0.84	891	7.4	2.5	1.2	2.3	10	2500	
IE3-W42R 400 M4	400	50	560	3582	1493	96.3	96.3	96.0	0.87	965	10.5	2.0		2.5	12.6	2900	
IE3-W42R 400 MX4	400	50	630	4027	1494	96.5	96.5	96.0	0.86	1096	10	3.1		3.3	14.33	3100	
IE3-W42R 400 L4	400	50	710	4541	1493	96.5	96.5	96.5	0.86	1235	11.4	4.1		3.8	16.29	3400	
Synchronous speed 1000 rpm – 6-pole version																	
IE3-W41R 355 MY6	400	50	132	1267	995	95.4	95.0	94.0	0.80	250	10.0	2.4	1.9	3.6	8.1	1550	
IE3-W41R 355 M6	400	50	160	1536	995	95.6	95.6	95.2	0.86	281	7.5	1.6	1.3	2.4	8.2	1850	
IE3-W41R 355 MX6	400	50	200	1919	995	95.8	95.5	95.0	0.86	350	9	1.9	1.7	2.7	12.1	2200	
IE3-W41R 355 L 6	400	50	250	2395	997	95.8	95.5	95.0	0.84	448	8.8	2.2	1.5	2.8	14	2450	
IE3-W41R 355 LX6	400	50	315	3023	995	95.8	95.7	95.3	0.84	565	7.5	1.6	1.1	2.3	14	2450	
IE3-W42R 355 MX6	400	50	200	1919	995	95.8	95.5	95.0	0.84	359	9.6	2.2	1.7	2.8	12.1	2350	
IE3-W42R 355 LY6	400	50	250	2399	995	95.8	95.5	95.0	0.82	459	8.0	1.8	1.5	2.5	14	2450	
IE3-W42R 355 L6	400	50	315	3023	995	95.8	96.0	95.7	0.84	565	7.8	2.0	1.5	2.2	14	2450	
IE3-W42R 355 LX6	400	50	355	3407	995	95.8	95.8	95.4	0.81	660	8.4	2.1	1.4	2.7	14	2450	
IE3-W42R 355 LZ6	400	50	400	3843	994	95.8	95.8	95.4	0.83	726	7.6	2.1	1.3	2.3	14	2450	
IE3-W42R 400 MY6	400	50	355	3407	995	96.0	96.0	95.8	0.83	643	7.5	1.2	1.2	2.1	16.54	3000	
IE3-W42R 400 M6	400	50	400	3839	995	96.2	96.2	96.0	0.83	723	8.0	1.5	1.3	2.5	16.54	3000	
IE3-W42R 400 MX6	400	50	450	4314	996	96.0	96.0	95.8	0.84	805	7.6	1.5		2.2	18.44	3100	
IE3-W42R 400 L6	400	50	500	4794	996	96.3	96.3	96.0	0.84	892	7.5	1.7		2.2	20.63	3320	
IE3-W42R 400 LX6	400	50	560	5369	996	96.4	96.4	96.4	0.82	1023	7.5	1.7		2.2	20.63	3320	
Synchronous speed 750 rpm – 8-pole version																	
IE3-W41R 355 MY8	400	50	160	2051	745	94.3	94.3	94.0	0.82	299	6.6	1.2	1.0	2.6	9.3	1700	
IE3-W41R 355 M8	400	50	200	2564	745	94.7	94.9	94.2	0.81	376	7.0	1.0	1.0	2.7	9.5	1890	
IE3-W41R 355 MX8	400	50	250	3204	745	95.0	95.0	95.0	0.83	458	7.0	1.2	1.0	2.6	13.4	2200	
IE3-W41R 355 L8	400	50	280	3594	744	95.3	95.3	95.0	0.78	544	7.2	1.2	1.0	2.6	15.8	2400	
IE3-W42R 355 MX8	400	50	250	3204	745	94.6	94.4	93.5	0.68	561	5.2	1.4	1.3	2.0	13.4	2300	
IE3-W42R 355 L8	400	50	315	4038	745	95.0	95.0	95.0	0.73	656	5.7	2.0	1.5	2.2	15.8	2450	
IE3-W42R 400 M8	400	50	355	4550	745	95.0	95.0	95.0	0.74	729	6.5	1.5	1.3	1.8	17.94	2800	
IE3-W42R 400 MX8	400	50	400	5127	745	95.6	95.5	95.0	0.69	875	5.6	1.3	1	2	19.99	3170	
IE3-W42R 400 L8	400	50	450	5768	745	95.0	95.0	95.0	0.74	924	6	1.5	1.3	1.8	22.34	3320	

Bearings

Type	D-end										N-end			Figure of bearing				
	Light bearing LL					Heavy bearing VL					Pressure spring			D-end	D-end	N-end		
	Type of construction	Bearing type	Disc spring	Type	Units	V-ring	γ-ring	Bearing type	Disc spring	V-ring	γ-ring	Bearing type	V-ring	Type	Units	LL	VL	LL
IE3-W41R 355 M2	IM B3 IM V1	6317 C3	180	-	-	-	85	NU 317 E	180	-	85	6317 C3 Q317 C3	85A	-	-	1	2	3
IE3-W41R 355 M4, 6	IM B3 IM V1	6324 J C3	260	-	-	-	120	NU 324 E	260	-	120	6317 C3 Q317 C3	85A	-	-	1	2	3
IE3-W41R 355 MY8, M8	IM B3 IM V1	6324 J C3	260	-	-	-	120	NU 324 E	260	-	120	6317 C3 Q317 C3	85A	-	-	1	2	3
IE3-W42R 355 MX2, L2	IM B3 IM V1	6317 C3	180	-	-	-	85	NU 317 E	180	-	85	6317 C3 Q317 C3	85A	-	-	1	2	3
IE3-W42R 355 MX4, 6, 8; L4, 6, 8	IM B3 IM V1	6324 J C3	260	-	-	-	120	NU 324 E	260	-	120	6317 C3 Q317 C3	85A	-	-	1	2	3
IE3-W42R 400 M2, MX2, L2	IM B3	6317 C3	-	OD12110 1.1200	12	-	85	NU 317 E	-	-	85	6317 C3	85A	-	-	4	2	3
	IM V1	7317B	-	-	-	-	85	7218B + NU218 E	-	-	90	6317 C3	85A	OD12110 1.1200	12	1	5	6
IE3-W42R 400 M4, 6, 8; MX4, 6, 8; L4, 6, 8	IM B3	6324 J C3	-	OD22400 1.4310	12	-	120	NU 324 E	-	-	120	6319 C3	85A	-	-	4	2	3
	IM V1	7324B	-	-	-	-	85	7226B + NU226 E	-	-	90	6319 C3	85A	OD12110 1.1200	21	1	5	6

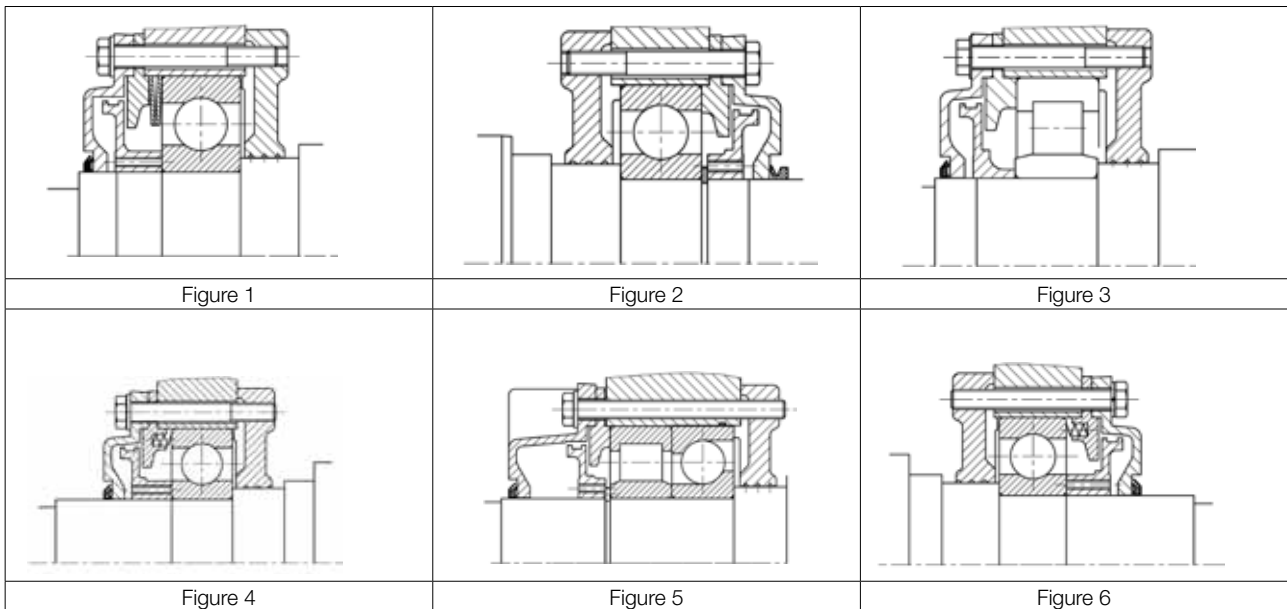

Terminal boxes

Standard design, VIK design

Type	Material	Intermediate flange	Dimensions				Thread ingoing cables	max. cable diameter	Terminal board	Number of terminals	Thread connecting bolt	Thread earth connector	Figure
			AG x	LL z	AH -	BE -							
Standard design													
630 A	GG-15	straight	496	390	301	140	M72 x 2	Ø 56.5 mm	KLP 630-20	6	M20	LK	03G
630 A	GG-15	inclined	496	390	301	140	M72 x 2	Ø 56.5 mm	KLP 630-20	6	M20	LK	03S
1000 A	GG-15	straight	615	474	385	200	M72 x 2	Ø 56.5 mm	KLSO 1000	6	StS	LK	04G
1000 A	GG-15	inclined	615	474	385	200	M72 x 2	Ø 56.5 mm	KLSO 1000	6	StS	LK	04S
1000 A	GG-15	straight	615	474	385	200	M80 x 2	Ø 68 mm	KLSO 1000	6	StS	LK	04G
1000 A	GG-15	inclined	615	474	385	200	M80 x 2	Ø 68 mm	KLSO 1000	6	StS	LK	04S
VIK design													
630 A Ex eb IIC	GG-15	straight	496	390	301	140	M75 x 1.5	Ø 45 mm	KLP 630-20	6	LK	LK	06G
630 A Ex eb IIC	GG-15	inclined	496	390	301	140	M75 x 1.5	Ø 45 mm	KLP 630-20	6	LK	LK	06S
1000 A Ex eb IIC	GG-15	straight	615	474	385	200	M80 x 1.5	Ø 68 mm	KLSO 1000	6	StS	LK	07G
1000 A Ex eb IIC	GG-15	inclined	615	474	385	200	M80 x 1.5	Ø 68 mm	KLSO 1000	6	StS	LK	07S

StS... current bar

LK... saddle terminal

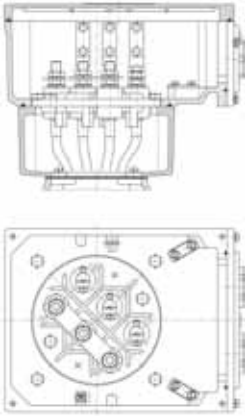

Figure 03G
Terminal box 630 A,
straight intermediate flange

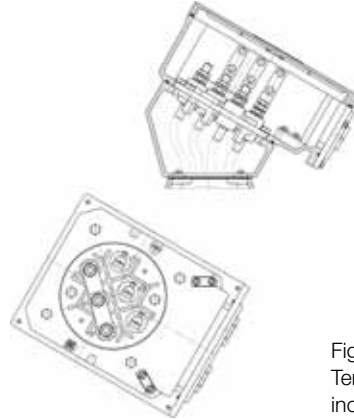

Figure 03S
Terminal box 630 A,
inclined intermediate flange

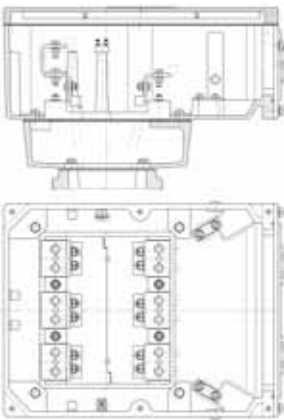

Figure 04G
Terminal box 1000 A,
straight intermediate flange

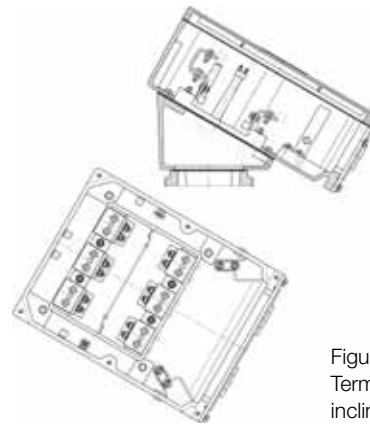

Figure 04S
Terminal box 1000 A,
inclined intermediate flange

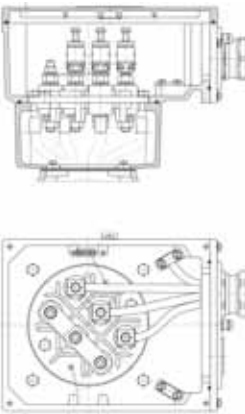

Figure 06G
Terminal box 630 A, Ex eb IIC
straight intermediate flange

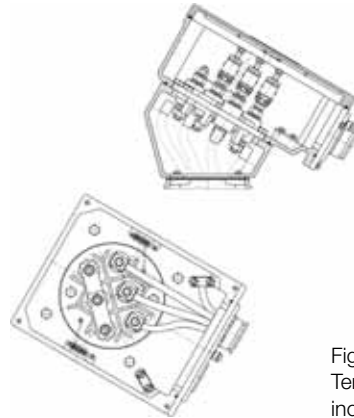

Figure 06S
Terminal box 630 A, Ex eb IIC
inclined intermediate flange

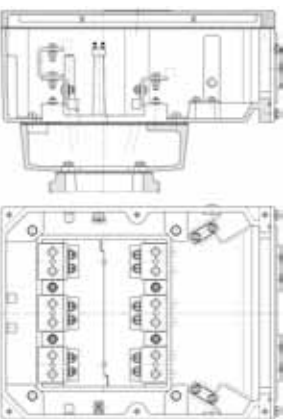

Figure 07G
Anschlusskasten 1000 A, Ex eb IIC
straight intermediate flange

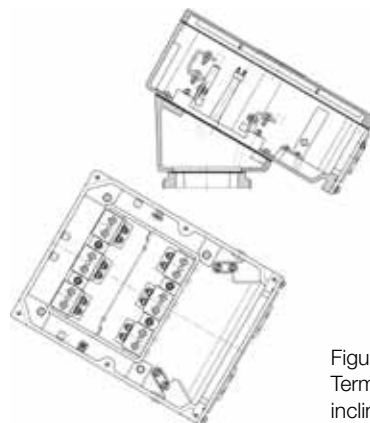

Figure 07S
Terminal box 1000 A, Ex eb IIC
inclined intermediate flange

Dimensions

Flange dimensions

Flange type acc. to DIN EN 50 347	Flange type acc. to DIN 42948	LA c ₁	M e ₁	N b ₁	P a ₁	S s ₁	T f ₁
FF 600	A 660	22	600	550	660	22	6
FF 740	A 800	25	740	680	800	22	6
FF 940	A1000	25	940	880	1000	28	6

In EN 50347 the flanges FF with through hole are assigned to the shaft sizes.
The standard DIN 42948 is still valid for flanges A and C.

Tolerances for dimension N (b₁) see corresponding dimensional tables
LA (c₁) length of engagement

**Energy saving motors, Premium Efficiency IE3
Transnorm three-phase motors with squirrel-cage rotor**

Surface ventilation, type of cooling IC 411, degree of protection IP 55
Size 355 to 400

Type of construction IM B3 [IM 1002], 2-pole

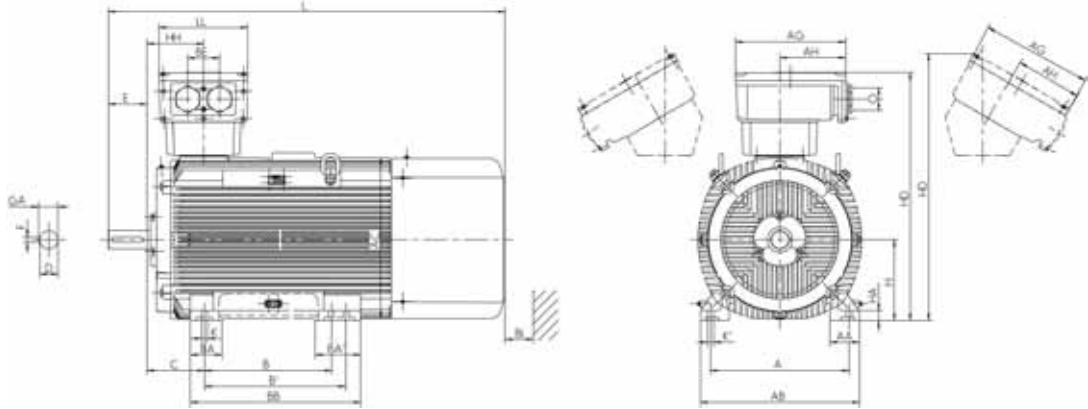

Type of construction IM B3 [IM 1002], 4- to 8-pole

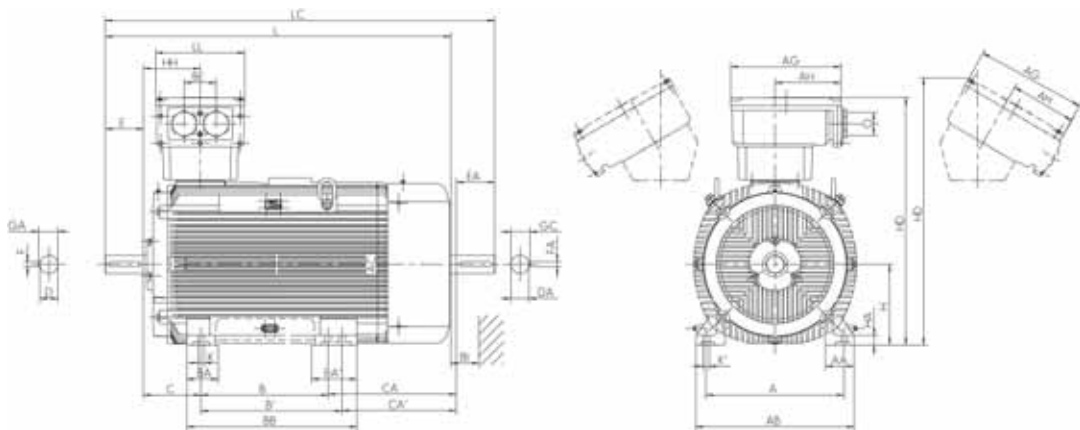

Type designation	Flange size	A	AA	AB	AC	B	BA	BA'	BB	C	CA	D	DA	DB ¹⁾	E	EA	F	FA
		b	n	f	g	a	m	m1	e	w1	w2	d	d1		l	l1	u	u1
IE3-W41R 355 MY2G, M2G	FF 740	610	130	700	715	560	140	200	750	254	561	80	80	M20	170	-	22	-
IE3-W41R 355 MY4, M4	FF 740	610	130	700	715	560	140	200	750	254	561	100	80	M24	210	170	28	22
IE3-W41R 355 MY6, 8, M6, 8	FF 740	610	130	700	715	560	140	200	750	254	561	100	80	M24	210	170	28	22
IE3-W42R 355 MX6, 8	FF 740	610	130	700	715	560	140	200	750	254	761	100	80	M24	210	170	28	22
IE3-W42R 355 MX2G	FF 740	610	130	700	715	560	140	200	750	254	761	80	80	M20	170	-	22	-
IE3-W42R 355 L2G	FF 740	610	130	700	715	630	140	200	750	254	691	80	80	M20	170	-	22	-
IE3-W42R 355 MX4	FF 740	610	130	700	715	560	140	200	750	254	761	100	80	M24	210	170	28	22
IE3-W42R 355 L4	FF 740	610	130	700	715	630	140	200	750	254	691	100	80	M24	210	170	28	22
IE3-W42R 355 L6, 8	FF 740	610	130	700	715	630	140	200	750	254	691	100	80	M24	210	170	28	22
IE3-W42R 400 M2G, MX2G	FF940	686	178	820	800	630	180	240	900	280	930	80	80	M20	170	-	22	-
IE3-W42R 400 L2G	FF940	686	178	820	800	710	180	240	900	280	850	80	80	M20	170	-	22	-
IE3-W42R 400 M, MX 4, 6, 8	FF940	686	178	820	800	630	180	240	900	280	930	110	80	M24	210	170	28	22
IE3-W42R 400 L4, 6, 8	FF940	686	178	820	800	710	180	240	900	280	850	110	80	M24	210	170	28	22

¹⁾ Centre holes acc. to DIN 332-DS

Energy saving motors, Premium Efficiency IE3 Transnorm three-phase motors with squirrel-cage rotor

Surface ventilation, type of cooling IC 411, degree of protection IP 55
Size 355 to 400

Type of construction IM B35 [IM 2002], 2-pole

Flange dimensions see page 3/9

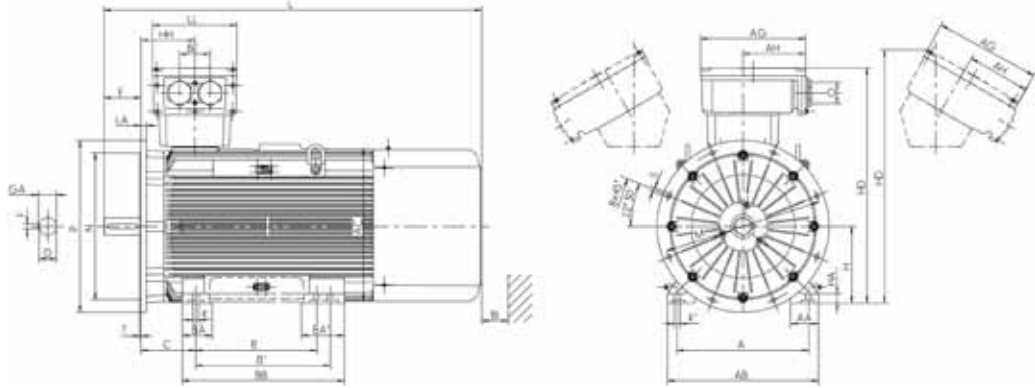

Type of construction IM B35 [IM 2002], 4- to 8-pole

Flange dimensions see page 3/9

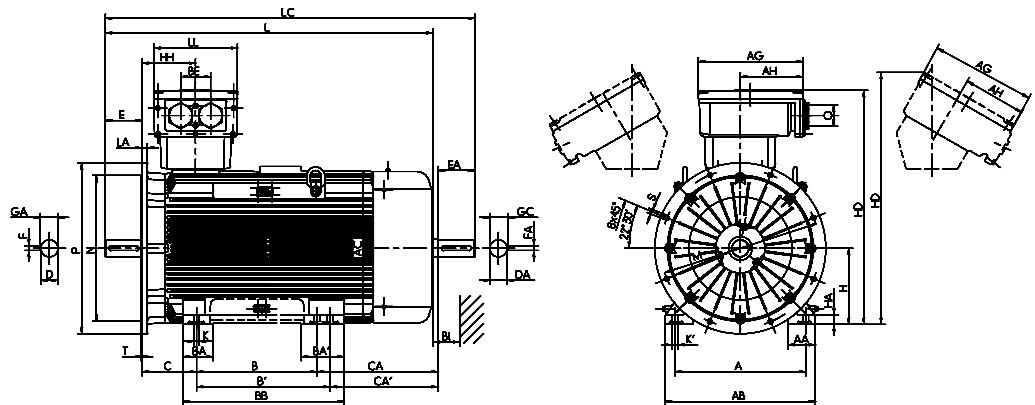

Type designation	GA	GC	H	HA	HD	HD**)	HH	K	K'	L	LC	TB Type	AG	LL	AH	BE	O	BI
	t	t1	h	c	p	p	A	s	s'	k	k1		x	z	-	-	r	Bl
IE3-W41R 355 MY2G, M2G	85	-	355	44	1091	1168	250	28	35	1530	-	630 A	496	390	301	140	M72 x 2	60
IE3-W41R 355 MY4, M4	106	85	355	44	1091	1168	250	28	35	1570	1755	630 A	496	390	301	140	M72 x 2	60
IE3-W41R 355 MY6, 8, M6, 8	106	85	355	44	1091	1168	250	28	35	1570	1755	630 A	496	390	301	140	M72 x 2	60
IE3-W42R 355 MX6, 8	106	85	355	44	-	1166	327	28	35	1770	1955	630 A	496	390	301	140	M72 x 2	60
IE3-W42R 355 MX2G	85	-	355	44	-	1172	327	28	35	1730	-	1000 A	615	474	385/596*	200	M72 x 2	60
IE3-W42R 355 L2G	85	-	355	44	-	1172	327	28	35	1730	-	1000 A	615	474	385/596*	200	M72 x 2	60
IE3-W42R 355 MX4	106	85	355	44	-	1172	327	28	35	1770	1955	1000 A	615	474	385/596*	200	M72 x 2	60
IE3-W42R 355 L4	106	85	355	44	-	1172	327	28	35	1770	1955	1000 A	615	474	385/596*	200	M72 x 2	60
IE3-W42R 355 L6, 8	106	85	355	44	-	1172	327	28	35	1770	1955	1000 A	615	474	385/596*	200	M72 x 2	60
IE3-W42R 400 M2G, MX2G	85	-	400	50	-	1273	339	35	42	1963	-	1000 A	615	474	385/596*	200	M80 x 2	100
IE3-W42R 400 L2G	85	-	400	50	-	1273	339	35	42	1963	-	1000 A	615	474	385/596*	200	M80 x 2	100
IE3-W42R 400 M, MX 4, 6, 8	116	85	400	50	-	1273	339	35	42	2003	2201	1000 A	615	474	385/596*	200	M80 x 2	100
IE3-W42R 400 L4, 6, 8	116	85	400	50	-	1273	339	35	42	2003	2201	1000 A	615	474	385/596*	200	M80 x 2	100

** Terminal box inclined left/right

**Energy saving motors, Premium Efficiency IE3
Transnorm three-phase motors with squirrel-cage rotor**

Surface ventilation, type of cooling IC 411, degree of protection IP 55
Size 355 to 400

**Type of construction IM B5 [IM 3001],
IM V1 [IM 3011], 2-pole**

Flange dimensions see page 3/9

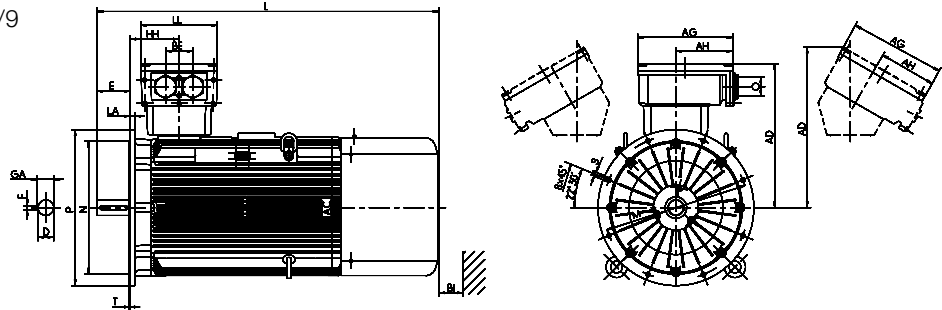

**Type of construction IM B5 [IM 3001],
IM V1 [IM 3011], 4- bis 8-polig**

Flange dimensions see page 3/9

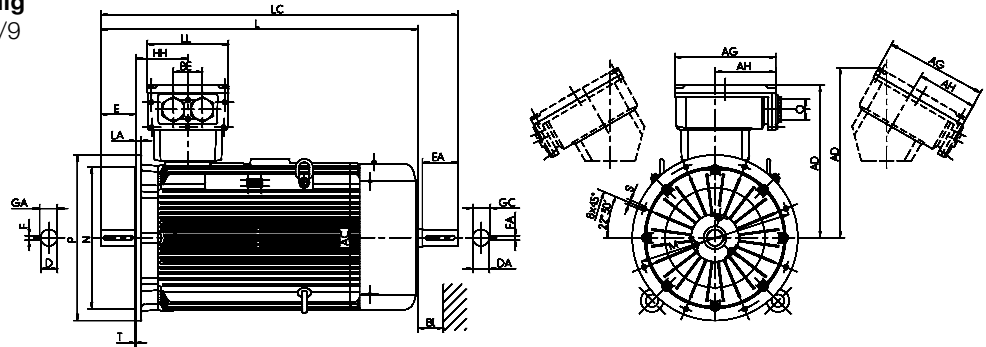

Type designation	Flange size	AC g	AD g1	AD'' ¹⁾ g1	D d	DA d1	DB'' ¹⁾	E l	EA l1	F u	FA u1	GA t	GC t1
IE3-W41R 355 MY2G, M2G	FF 740	715	736	813	80	-	M20	170	170	22	22	85	85
IE3-W41R 355 MY4, M4	FF 740	715	736	813	100	80	M24	210	170	28	22	106	85
IE3-W41R 355 MY6, 8, M6, 8	FF 740	715	736	813	100	80	M24	210	170	28	22	106	85
IE3-W42R 355 MX6, 8	FF 740	715	-	811	100	80	M24	210	170	28	22	106	85
IE3-W42R 355 MX2G	FF 740	715	-	817	80	-	M20	170	170	22	22	85	85
IE3-W42R 355 L2G	FF 740	715	-	817	80	-	M20	170	170	22	22	85	85
IE3-W42R 355 MX4	FF 740	715	-	817	100	80	M24	210	170	28	22	106	85
IE3-W42R 355 L4	FF 740	715	-	817	100	80	M24	210	170	28	22	106	85
IE3-W42R 355 L6, 8	FF 740	715	-	817	100	80	M24	210	170	28	22	106	85
IE3-W42R 400 M2G, MX2G	FF 940	810	-	873	80	-	M20	170	-	22	22	85	85
IE3-W42R 400 L2G	FF 940	810	-	873	80	-	M20	170	-	22	22	85	85
IE3-W42R 400 M, MX 4, 6, 8	FF 940	810	-	873	110	80	M24	210	170	28	22	116	85
IE3-W42R 400 L4, 6, 8	FF 940	810	-	873	110	80	M24	210	170	28	22	116	85

Type designation	H h	HA c	L k	LC k1	TB Type	AG x	LL z	AH -	AH	BE -	O r	BI BI
IE3-W41R 355 MY2G, M2G	355	44	1530	1715	630 A	496	390	301		140	M72 x 2	60
IE3-W41R 355 MY4, M4	355	44	1570	1755	630 A	496	390	301		140	M72 x 2	60
IE3-W41R 355 MY6, 8, M6, 8	355	44	1570	1755	630 A	496	390	301		140	M72 x 2	60
IE3-W42R 355 MX6, 8	355	44	1770	1955	630 A	496	390	301		140	M72 x 2	60
IE3-W42R 355 MX2G	355	44	1730	1915	1000 A	615	474	385	596	200	M72 x 2	60
IE3-W42R 355 L2G	355	44	1730	1915	1000 A	615	474	385	596	200	M72 x 2	60
IE3-W42R 355 MX4	355	44	1770	1955	1000 A	615	474	385	596	200	M72 x 2	60
IE3-W42R 355 L4	355	44	1770	1955	1000 A	615	474	385	596	200	M72 x 2	60
IE3-W42R 355 L6, 8	355	44	1770	1955	1000 A	615	474	385	596	200	M72 x 2	60
IE3-W42R 400 M2G, MX2G	400	50	1963	2161	1000 A	615	474	385	596	200	M80 x 2	100
IE3-W42R 400 L2G	400	50	1963	2161	1000 A	615	474	385	596	200	M80 x 2	100
IE3-W42R 400 M, MX 4, 6, 8	400	50	2003	2201	1000 A	615	474	385	596	200	M80 x 2	100
IE3-W42R 400 L4, 6, 8	400	50	2003	2201	1000 A	615	474	385	596	200	M80 x 2	100

¹⁾ Centre holes acc. to DIN 332-DS

²⁾ Terminal box inclined left/right



VEM  DRIVE

Motors for converter-fed operation

Contents

Product description	4/2
Overview of technical data	4/7

Motor selection data

Standard insulation (up to 420 V):

Series IE3-W4.R, IE2-WE.R, K2.R	4/8
---------------------------------------	-----

KU insulation (> 420 V up to 500 V):

Series IE3-WU.R, IE2-WU.R, KU.R	4/22
---------------------------------------	------

KV insulation (> 500 V up to 690 V):

Series KV.R	4/38
-------------------	------

Equivalent circuit data	4/41
-------------------------------	------

Mechanical limit speeds	4/47
-------------------------------	------

Bearings

Identical to bearings of standard motors
see Chapter 2

Terminal boxes

Identical to bearings of standard motors
see Chapter 2

Dimensions

Identical to dimension of standard motors
see Chapter 2

Product description

Whenever speed control is desirable or perhaps even indispensable for a given application, it is necessary to choose a motor suitable for operation on a frequency converter. In this respect, VEM offers ideal drive solutions for the most varied branches.

Generally speaking, all squirrel-cage motors from VEM can be operated on a frequency converter.

The corresponding drives are cost-effective as they are based on a modular system. VEM motors are suitable for converter-fed operation and can be matched to all low voltages.

If basic parameters of the drive system are unknown (e.g. compliance with NAMUR recommendations), special

measures must be taken to prepare the motor for converter-fed operation. The configuration of an electric drive system without knowledge of all interactions between the components can result in damage to the winding insulation and motor bearings. The voltage pulse at the motor terminals can reach very high amplitudes. Depending on the mode of operation of the motor, e.g. braking, and the type, length and routing of the motor cable, as well as in conjunction with active input power converters, pulse voltage peaks in excess of twice the link voltage of the converter may occur. The pulse voltages specified in Table 1 below are to be observed as maximum values.

Mains voltage = converter output voltage U_N	Converter DC link voltage $U_z = U_N \times 1.35$	Max. pulse voltage \hat{U}_{LL}
400	540	1350 V
440	594	1485 V
500	675	1690 V
600	810	2025 V
690	930	2330 V

Table 1: Maximum pulse voltages

Voltage stresses (insulation systems)

Table 2 shows the insulation systems used by VEM, the maximum permissible pulse voltages \hat{U}_{LL} and the options for operation with different mains voltages. The prerequisite

in each case is that the windings must be configured for star connection if the motors are operated without a filter at the converter output. The following conditions apply:

- x ... Converters without input rectifier control → no limitations
- 1 ... No regenerative or braking operation
- 2 ... No regenerative or braking operation,
no use in complex drive systems with central DC link,
no voltage boosting by way of a controlled input power converter
- ... Motor operation not permissible without a filter at the converter output
- A ... May be possible in accordance with (2) upon request

Types/series	Standard series	Standard series	KU.R, KU.F, WU.R, WU.F		KV.R, KV.F
Insulation system	to Sp2945	Standard	Reinforced KU		Reinforced KV
Sizes BG	≤ 132	≥ 132	≤ 132	≥ 132	≥ 132
Basic data \hat{U}_{LL}	1350 V		1560 V	1800 V	2500 V
du/dt	< 1.5 kV/μs		< 3.0 kV/μs		< 5.0 kV/μs
Mains voltages					
up to 400 V	x		x		x
up to 440 V	1		x		x
up to 500 V	2		2	x	x
up to 600 V	-		-	2	x
up to 690 V	-		-		x

Table 2: VEM insulation systems for converter-fed motors

Converter-fed motors in VIK design,
VE 01 – Three-phase asynchronous motors – Technical requirements – Status March 2011,
Output voltages at the converter ≤ 690 V

According to section 6.7 of the VIK recommendation, motors may be subjected to a maximum peak voltage of 1350 V in accordance with DIN IEC 60034-17, Fig. 6, and a rate of voltage rise of 1.5 kV/μs at the motor terminals. If the peak voltages and/or rates of voltage rise exceed the aforemen-

tioned values, the lifetime of the insulation will be reduced to a greater or lesser extent. As this is excluded by the VIK recommendation, VIK motors for converter-fed operation without separately agreed peak voltage are designed as series K2.R/WE.R/W4.R.

From IEC frame size 315, VEM always recommends the use of an insulated bearing at the non-drive end. In this way, bearing currents are reduced to a level at which there is no risk of damage to the bearings. There are many possible causes

of bearing currents. On the one hand, the common-mode voltage produced by the converter may result in damage. On the other hand, inadequate motor earthing or cable shielding can also lead to bearing damage.

Notes on the configuration of motors for operation on a frequency converter

A motor is only one component of a complex electric drive system. Even so, poor overall configuration of the drive system is often only manifested in reduced motor performance, whereas unsuitable parameterisation may also become evident at the transmission elements such as couplings and belt drives. Modern converters generally protect themselves and the motor against thermal overloads. Impermissible voltage peaks at the motor terminals, however, are not detected. If there is no corresponding circuitry at the converter output and/or if the cables are too long, there is thus a risk of damage to the motor insulation.

There are several ways in which to optimise the drive system:

- Output circuitry at the converter (reactor, du/dt filter or sine-wave filter)
- Motor with reinforced insulation
- Combination of the above (especially recommended with mains voltage > 500 V).

The planning of a complete drive system requires knowledge of all possible interactions between the components used. The project engineer must select the components of a drive system very carefully. He is decisively responsible for ensuring that the permissible voltage values are not exceeded at the motor terminals. Taking into account the influences of all other components, he must furthermore specify the necessary motor insulation. Examples of components with decisive influence for the stresses placed on the motor insulation:

Output reactors

Output reactors reduce the capacitive recharging currents in case of long cables. Due to the form of the output voltage from the converter, capacitive components are especially detrimental with long cables. The cable capacitances result in recharging currents which must be supplied by the converter in addition to the motor current. With long motor cables (and when operating several motors), the total current (motor and recharging current) may increase to the point at which the peak output current is exceeded. In such cases, the converter will be switched off with the error message "Overcurrent".

When shielded cables are used for reasons of electromagnetic compatibility (EMC), the critical cable length is reduced further, as the shielding produces additional capacitances together with the power cables. The recharging currents can be reduced significantly by incorporating a reactor. In this way, the switching losses in the converter are reduced. Together with the cable capacitances, the output reactor lowers the rate of voltage rise at the motor terminals. It prevents the formation of high pulse voltages, but does not reduce existing voltage peaks. For this reason, we advise installation of the output reactor as close as possible to the converter.

du/dt filter

The high switching frequencies which follow from very short switching intervals may result in rates of voltage rise in excess of 10 kV/μs at the converter output. With short cables, this can shorten the lifetime of the motor insulation.

Through the use of a du/dt filter, it is possible to limit the rate of voltage rise to less than 500 V/μs and the pulse amplitude to less than 1000 V.

If the electric strength of the motor insulation is unknown or the motor cables are very short, a du/dt filter should be used. For long cables, it may be necessary to provide either one or two reactors in addition to the du/dt filter.

Sine-wave filter

Sine-wave filters modify the non-sinusoidal output voltage of the converter into a sinusoidal phase-to-phase motor voltage. The benefit of a sine-wave filter lies in significant improvement of the total harmonic distortion of the voltage (practically sinusoidal). Special insulation is not necessary. True running is improved, motor losses are reduced and there is less magnetic motor noise.

A disadvantage of a sine-wave filter, however, is the no longer negligible voltage drop. The output voltage at the filter may be reduced by up to 15 %, i.e. either the transition frequency of the converter must be reduced by approx. 15 %, which could make it necessary to provide a larger motor, or else the motor winding must be adapted to the reduced input voltage.

Comprehensive motor protection can be achieved with all-pole sine-wave filters. With these filters, the phase-to-earth voltages are also sinusoidal. Motors with standard insulation as well as unshielded and very long motor cables can be used. All-pole filters are used above all for motors where maintenance is difficult. They are similarly meaningful for the retrofitting of drives with unshielded and/or long motor cables.

Self-ventilation (IC 411) and forced ventilation (IC 416)

When the speed of a self-ventilated motor decreases, the cooling air volume is reduced linearly and the pressure drops quadratically. Fan performance decreases cubically with the speed. As the motor losses are also lower, however, the reduced cooling effect only becomes evident at less than half of the rated speed. Where a self ventilated motor is intended for continuous operation at low speeds, it may be necessary to select a larger motor, depending on the required torque. At speeds above the rated speed, a significant increase in fan noise is to be expected, especially with 2- and 4-pole motors.

If an optional forced ventilation unit is added, a motor can also deliver a high continuous torque at lower speeds. At higher speeds, the noise level is reduced significantly compared to self-ventilation; at the same time, however, the available output decreases with increasing speed.

Mechanical limit speeds

In case of operation above 60 Hz, the permissible limit speeds of the motor must be observed. For such cases, VEM recommends the use of an optional HS (high-speed) motor version. The relubrication intervals of the bearings are also shortened with increasing speed. It may thus be expedient to incorporate a relubrication system for motors from IEC size 160.

Motors for frequencies over 100 Hz can be supplied upon request.

Ohmic stator resistance of smaller motors

With lower motor outputs, it is increasingly necessary to take the relatively high ohmic stator resistance into account. Compensation must be provided in the form of overproportionate raising of the converter output voltage at lower frequencies (IxR compensation for U/f controllers). This measure enables reliable acceleration to the desired setpoint speed under load. In the case of converters with field-oriented control, the flux adaptation is automatic.

Breakdown torque

The effective acceleration torque is normally assumed to be approx. 70 % of the breakdown torque. When a motor is operated in the field-weakening range (operation with constant voltage above the rated frequency of the motor), the breakdown torque is reduced quadratically with increasing frequency. It is thus important to ensure that a torque ratio of $M_k/M_N > 1.6$ is maintained at all times.

Commissioning and parameterisation of the converter

Converters must be commissioned and parameterised in accordance with the applicable commissioning and parameterisation instructions. When doing so, all aspects relevant for the specific application must be taken into account, for example

- Input of motor data (see rating plate)
- Connection of optional motor components (PTC, encoder, brake, forced ventilation unit, etc.)
- Torque characteristic of the driven machine (constant, square-law, etc.)
- Control mode (U/f characteristic, field-oriented control, etc.)
- Dynamic requirements (ramp-up and braking times)

Ecodesign to DIN EN 50598

Following the transition to energy-saving designs and IE efficiency classifications for asynchronous motors operated on a mains supply, the next step is to extend the scope of the classifications to include also power electronics components and systems, as well as driven equipment.

The standard comprises three parts. Part 2 contains specifications on determination and evaluation of the energy efficiency of drive systems for the output range from 0.12 kW to 1000 kW.

It also includes a proposal for the procedure to characterise the most energy-efficient solution for the so-called extended product comprising drive system and load machine. The standard specifies methods for determination of the losses of the complete drive module, the drive system and the overall motor system. Efficiency classes are defined for complete drive modules (IE classes) and drive systems (IES classes), and both limit values and test methods are provided to facilitate classification. Furthermore, methods are proposed for characterisation of the most energy-efficient solution, as dependent on the architecture of the motor drive system, the speed/load profile and the operating points of the application.

In future, specific data must be provided on losses and IE/IES classifications for all low-voltage drive systems incorporating three-phase asynchronous motors for the voltage range from 100 V to 1000 V.

The standard EN 50598-2 deals primarily with the complete drive modules and drive systems. Such modules – and the further components of an extended product – are represented in the following diagram (Fig. 1).

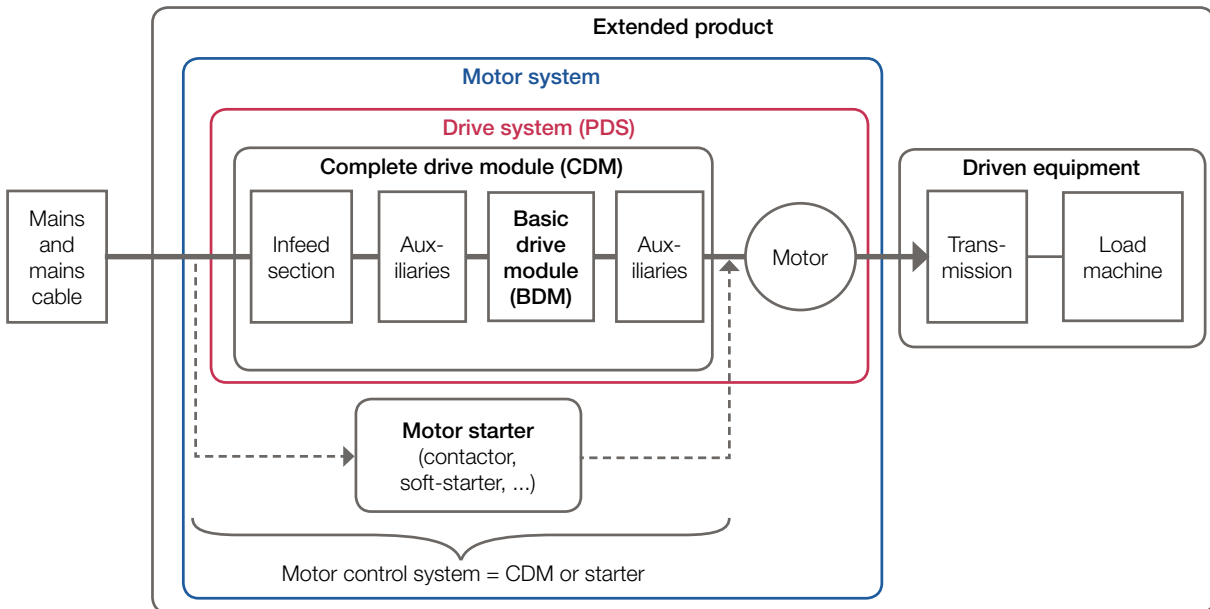

Fig. 1: Components of an extended product

Explanations of important abbreviations:

- **CDM** – Complete Drive Module
Complete frequency converter with power infeed, input and output filters, etc.
- **PDS** – Power Drive System
Drive system comprising CDM and motor, including the motor cable
- **EEI** – Energy Efficiency Index
Measure of the energy efficiency of an extended product, e.g. a pump drive. The smaller the EEI value, the lower the losses of the extended product.
- **IES class** – International Efficiency of Systems
Efficiency class of a drive system (PDS)
- **RCDM** – Reference CDM
The measured or calculated losses of an individual CDM are assessed in comparison to the losses of a reference CDM. The power loss of the reference CDM is assigned to efficiency class IE1. The RCDM also serves to enable motor manufacturers to determine the IES class of a PDS without knowledge of the real CDM and its manufacturer.
- **RM** – Reference motor
The measured or calculated losses of an individual motor are assessed in comparison to the losses of a reference motor. The RM also serves to enable converter manufacturers to determine the IES class of a PDS without knowledge of the real motor and its manufacturer. The losses of the RM were derived from the IE2 efficiency classification of 4-pole asynchronous motors for 50 Hz in accordance with IEC/EN 60034-30, taking into account the rHL factors (ratios of the additional harmonic losses to the losses for a sinusoidal motor supply). The losses of the RM are also valid for 60 Hz applications.
- **RPDS** – Reference PDS (combination of reference motor and reference PDS)
The measured or calculated losses of a PDS are compared to the losses of a reference PDS. The power loss of the reference PDS is assigned to efficiency class IES 1. The reference PDS also serves to enable pump manufacturers, for example, to determine the energy efficiency index of an extended product (in this case a pump based on the reference PDS) without knowledge of the real PDS, its real components (motor and CDM) and their manufacturers.

Reference products → Definition

To determine the most energy-efficient extended product for an application, it is necessary to be able to compare the most varied power electronics components, motors and systems in a simple manner. The extended product approach described in the standard EN 50598-1, which is not to be discussed in further detail here, makes this possible.

The reference products are independent of any real product of a particular manufacturer and permit:

- specifications of limit values for classifications
- classification of an actual PDS through comparison to the reference PDS
- classification of the CDM and application of the future standard IEC/TS 60034-30-2 for the classification of converter-fed motors

– determination of a small number of suitable measuring points or calculation results as a development basis for the energy consumption

The introduction of reference points enables a manufacturer to perform comparisons with the reference products and thereby to assign products to a particular IE or IES class. A manufacturer who supplies only motors, for example, can already determine the IES classification of a final PDS in advance, even without knowledge of the real CDM and its manufacturer. To this end, the losses of the manufacturer's own motor must be measured or calculated together with the reference CDM. At present, however, the IE classifications for converter-fed motors are still under discussion.

Reference products → Loss measurement points

Eight loss measurement points each have been specified for a reference motor, reference CDM or reference PDS. The determination of the losses of the reference CDM is not

to be discussed in further detail here. Fig. 2 shows the eight measurement points for the reference PDS. These same operating points are also specified for the reference motor.

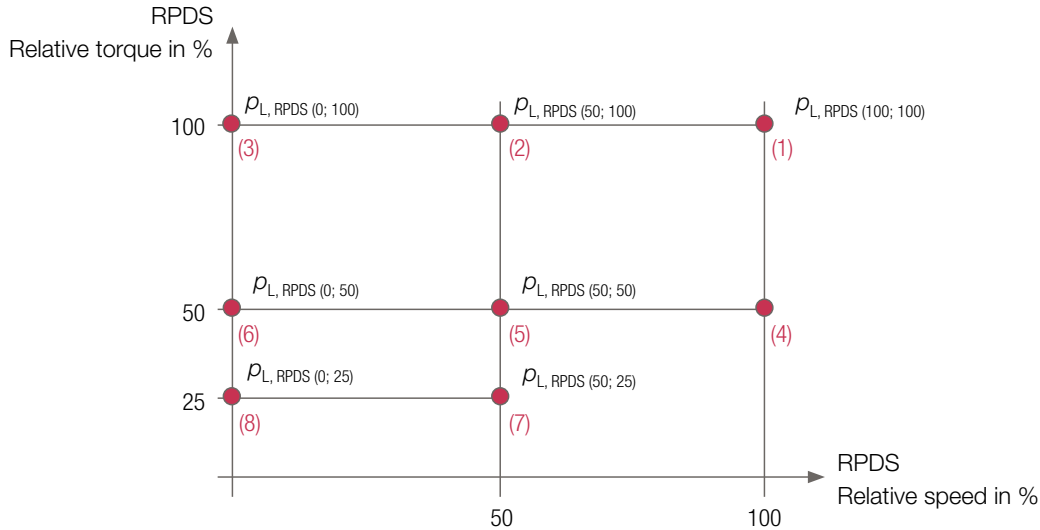

Fig. 2: Loss measurement points for the reference PDS

Theoretically, the losses must be known at every operating point between 0 % and 100 % of the relative speed and between 0 % and 100 % of the relative torque. In practice, however, it is sufficient to determine the losses at eight operating points.

Determination of the IE and IES classifications is nevertheless based exclusively on a comparison between the power losses of the real motor or real PDS and those of the reference motor or reference PDS at the rated operating point (100; 100).

If the power loss of a real PDS lies within +/- 20 % of the power loss of the reference PDS, then this PDS is assigned to class IES1. If the relative losses of the real PDS are less than 80 % compared to the reference PDS, the PDS can be assigned to class IES2. If the losses exceed those of the reference PDS by more than 20 %, then only class IES0 can be assigned.

For the end user, the various losses in partial-load operation are important. The levels of efficiency at actual partial loads must be calculated or measured on the basis of the eight operating points specified in the standard EN 50598, either by the user himself or by the supplier of the PDS. The methodology for calculation is described in the standard EN 50598.

IES class of PDS	PDS losses
IES0	> RPDS losses + 20 %
IES1	RPDS losses ± 20 %
IES2	< 80 % RPDS losses
IES3 to IES 9	(reserved)

Overview of technical data

The most important technical data are summarised in the following table.
Further information can be taken from the catalogue section "Introduction" (Chapter 1).

Product group	Squirrel-cage rotor, IEC/EN
Rated output	0.06 to 650 kW (non-classified, IE, IE1, IE2 and IE3 versions with 2, 4, 6 and 8 poles)
Sizes	56 to 400
Housing material	Grey cast iron
Rated torque	0.25 to 5130 Nm
Efficiency classification/ efficiency determination	IEC/EN 60034-30-1 /IEC/EN 60034-2-1, ≤ 1 kW direct measurement, > 1 kW residual loss method
Method of connection	Single-speed motors for converter-fed operation are designed preferably for star connection; delta configuration may be necessary from size 315.
Stator winding insulation	Thermal class 155, optional 155 [F(B)], 180 to IEC/EN 60034-1
Converter output voltages	up to 420 V, series K2.R, IE2-WE.R, IE3-W41R (see Chapter 2) >420 V up to 500 V, KU.R, IE2-WU.R, IE3-WU.R >500 V up to 690 V, KV.R, IE2-WV.R, IE3-WV.R
Degree of protection	IP 55 to IEC/EN 60034-5, optionally IP 56 and higher
Type of cooling	IC 411, IC 416, IC 71W (IC 31W) to IEC/EN 60034-6
Coolant temperature/ installation altitude	Standard -20 °C to +40 °C, Altitude 1000 m above sea level
Rated voltage	Standard voltages to EN 60038 50 Hz: 230 V, 400 V, 500 V, 690 V 60 Hz: 275 V, 460 V, 480 V, 600 V Voltage ranges A and B to IEC/EN 60034-1 (Prior consultation necessary regarding 230 V, 50 Hz and 275 V, 60 Hz for motors from size 315)
Duty types	S9, converter-fed operation
Types of construction	IM B3, IM B35, IM B5 and derived types to IEC/EN 60034-7
Paint finish	Normal finish "Moderate", colour RAL 7031, blue-grey Special finish "Worldwide", colour RAL 7031, blue-grey
Vibration severity grade	Grade "A" as standard for machines with no special vibration requirements
Shaft ends	to DIN 748 (IEC 60072), balanced with half-key
Limit speeds	Please refer to the section of "Limit speeds" in catalogue section "Motors for converter-fed operation", Chapter 4.
Bearing design	Please refer to the tables of "Bearing design data" in catalogue section „Standand motors“, Chapter 2.
Motor mass	Please refer to the technical selection lists.
Terminal boxes	Please refer to the section "Terminal boxes" in catalogue section „Standand motors“, Chapter 2.
Documentation	An operating and maintenance manual, a terminal plan and a safety data sheet are supplied with each motor.
Tolerances	Please refer to the section "Tolerances" in catalogue section "Introduction", Chapter 1.
Options	Please refer to the section "Overview of modifications" in catalogue section "Introduction", Chapter 1.

Three-phase motors with squirrel-cage rotor, Premium Efficiency IE3 for converter-fed operation without filter up to 420 V

with surface cooling, duty type S8, S9

for rated voltage, thermal class 155 (F), degree of protection IP 55, 50 Hz

Motor selection data												Design point 400 V, 50 Hz				
Type	P_B	M_B	P_B	n_B	η_B			$\cos\varphi_B$	I_B	I_A/I_B	M_A/M_B	M_S/M_B	M_K/M_B	J	m	
	Converter		Mains	rpm	(IEC/EN 60034-2)			-	400 V	-	-	-	-	kgm ²	kg	
	kW	Nm	kW		100 %	75 %	50 %		A							
Synchronous speed 1000 rpm – 6-pole version																
IE3-W41R 63 G6	0.12	1.23	0.12	930	IE3-	57.7	60.0	54	0.56	0.5	2.8	1.9	1.8	2.1	0.00045	6.7
IE3-W42R 71 KY6	0.18	1.89	0.18	910	IE3-	63.9	62.0	56.5	0.55	0.75	2.9	1.7	1.7	2.1	0.0006	8.3
IE3-W41R 71 GY6	0.25	2.54	0.25	940	IE3-	68.6	65.3	58.5	0.63	0.84	4	2.2	2.2	2.9	0.0013	10
IE3-W41R 80 K6	0.37	3.72	0.37	950	IE3-	73.5	72.9	69.2	0.7	1.03	4	1.9	1.9	2.4	0.00325	15
IE3-W41R 80 G6	0.55	5.53	0.55	950	IE3-	77.2	75.9	72.4	0.69	1.5	4.1	2.1	2.1	2.5	0.00425	18
IE3-W41R 90 SY6	0.75	7.50	0.75	955	IE3-	78.9	78.3	75.1	0.71	1.95	4.9	2.4	2.3	2.6	0.00625	24
IE3-W41R 90 L6	1.1	11.00	1.1	955	IE3-	81.0	81.0	78.5	0.72	2.75	5.4	2.5	2.4	2.8	0.0072	30
IE3-W41R 100 LX6	1.5	15.00	1.5	955	IE3-	82.5	83.5	81.5	0.76	3.45	5.9	2.3	2.2	2.8	0.0139	36
IE3-W41R 112 MV6	2.2	22.00	2.2	955	IE3-	84.3	83.6	80.9	0.74	5.15	5.7	2.4	2.3	2.9	0.0155	48
IE3-W41R 132 S6	3	30.0	3	965	IE3-	86.3	86.7	85.6	0.82	6.1	6.2	2.0	1.3	3.1	0.029	70
IE3-W41R 132 M6	4	40.0	4	965	IE3-	86.8	87.0	86.0	0.80	8.3	4.8	1.7	1.4	2.4	0.043	75
IE3-W41R 132 MX6	5.5	54.0	5.5	970	IE3-	88.6	88.6	87.2	0.80	11.0	6.0	2.1	1.7	3.0	0.053	105
IE3-W41R 160 M6	7.5	73.0	7.5	980	IE3-	90.2	90.0	88.3	0.83	14.5	6.4	2.4	2.0	3.0	0.145	145
IE3-W41R 160 L6C	11	107.0	11	985	IE3-	91.4	91.2	89.8	0.85	20.5	6.8	2.2	2	2.8	0.166	168
IE3-W41R 180 L6C	15	145.0	15	985	IE3-	91.2	91.3	90.2	0.87	27.5	6.8	2	1.7	2.7	0.3396	214
IE3-W41R 200 L6	18.5	180.0	18.5	980	IE3-	91.8	91.7	90.5	0.87	33.5	7.2	2.3	2	3	0.514	310
IE3-W41R 200 LX6C	22	213.0	22	985	IE3-	92.2	91.5	90	0.87	39.5	7.6	2.1	1.7	2.9	0.6476	321
IE3-W41R 225 M6	30	291	30	984	IE3-	92.9	92.2	91.0	0.84	55.5	7.2	2.7	2.2	2.9	0.92	400
IE3-W41R 250 M6	37	359	37	985	IE3-	93.3	93.2	92.3	0.86	66.5	7.1	2.8	2.0	2.7	1.48	545
IE3-W41R 280 S6	45	434	45	990	IE3-	93.7	93.5	91.5	0.86	80.5	8.5	2.1	1.8	2.8	2.63	695
IE3-W41R 280 M6	55	531	55	990	IE3-	94.2	94.1	93.1	0.85	99	9.0	2.2	1.9	3.1	3.33	815
IE3-W41R 315 S6	75	723	75	990	IE3-	94.6	94.0	93.5	0.86	133	8.2	1.8	1.4	2.3	5.55	1060
IE3-W41R 315 M6	90	868	90	990	IE3-	94.9	94.0	93.0	0.86	159	8.5	2.2	1.7	2.8	6	1100
IE3-W41R 315 MX6	110	1.061	110	990	IE3-	95.1	95.0	94.5	0.86	194	8.5	2.5	1.7	2.7	6.67	1210
IE3-W41R 315 L6	132	1.267	132	995	IE3-	95.4	95.0	94.5	0.87	230	9.0	2.8	2.0	3.2	8.6	1550
IE3-W41R 355 M6	160	1.536	160	995	IE3-	95.6	95.0	94.6	0.82	295	8.0	2.1	0.0	2.7	8.2	1850
IE3-W41R 355 MX6	200	1919	200	995	IE3-	95.8	95.0	94.0	0.85	355	9.0	2.1	0.0	2.9	12.10	2200
Synchronous speed 750 rpm – 8-pole version																
IE3-W41R 71 G8	0.12	1.67	0.12	685	IE3-	50.7	48.8	43	0.64	0.48	2.6	1.7	1.7	2	0.0013	9.9
IE3-W42R 80 K8	0.18	2.53	0.18	680	IE3-	58.7	56.3	49.8	0.61	0.73	2.6	1.6	1.6	2	0.00175	12
IE3-W41R 80 G8	0.25	3.39	0.25	705	IE3-	64.1	64.3	58.4	0.59	0.93	3	1.4	1.4	2.1	0.003	14
IE3-W42R 90 SY8	0.37	5.01	0.37	705	IE3-	69.3	67	61.2	0.56	1.39	3.1	1.6	1.6	2.2	0.00375	18.5
IE3-W41R 90 L8	0.55	7.50	0.55	700	IE3-	73.0	70.6	66.3	0.64	1.72	3.6	1.8	1.8	2.3	0.0072	26
IE3-W41R 100 LY8	0.75	10.1	0.75	710	IE3-	75.0	74.1	70.0	0.64	2.21	4.2	2.0	2.0	2.7	0.009	28
IE3-W41R 100 LW8	1.1	***	1.1													
IE3-W41R 112 M8	1.5	20.5	1.5	700	IE3-	79.7	78.7	76	0.65	4.25	3.8	1.6	1.5	2.1	0.0155	48
IE3-W41R 132 S8	2.2	29	2.2	725	IE3-	84.4	84.5	82.4	0.7	5.4	4.1	1.6	1.5	2.3	0.043	80
IE3-W41R 132 M8	3	40	3	720	IE3-	83.5	83.5	81.4	0.72	7	3.9	1.6	1.4	2.1	0.043	74
IE3-W41R 160 M8	4	52	4	735	IE3-	87	86.7	83.8	0.71	9.4	5.4	2.5	2.2	2.9	0.113	119
IE3-W41R 160 MX8	5.5	72	5.5	730	IE3-	87.5	87.5	85.6	0.73	12.5	4.7	1.9	1.7	2.5	0.145	143
IE3-W41R 160 L8	7.5	98	7.5	733	IE3-	87.9	87.6	85.6	0.73	17	5.1	2.1	1.8	2.7	0.166	155
IE3-W41R 180 L8	11	145	11	725	IE3-	89.3	89	87.1	0.75	23.5	5.4	2.1	1.9	2.8	0.228	175
IE3-W41R 200 L8	15	196	15	730	IE3-	89.6	90	89	0.80	30	5.3	1.8	1.7	2.5	0.324	235
IE3-W41R 225 S8	18.5	240	18.5	735	IE3-	90.1									0.514	310
IE3-W41R 225 M8	22	286	22	735	IE3-	91.5	91.6	90.6	0.79	44	5.7	2.3	2	2.5	0.825	360
IE3-W41R 250 M8	30	391	30	732	IE3-	91.3	91.9	91.4	0.81	58.5	5.4	2	1.8	2.3	0.92	420
IE3-W41R 280 S8	37	479	37	738	IE3-	92	92	90.8	0.78	74.5	5.9	2.3	1.8	2.4	1.55	555
IE3-W41R 280 M8	45	581	45	740	IE3-	93	93	92.4	0.78	89.5	6.5	1.7	1.5	2.4	2.63	700
IE3-W41R 315 S8	55	712	55	738	IE3-	92	92	90.8	0.78	74.5	5.9	2.3	1.8	2.4	3.33	805
IE3-W41R 315 M8	75	965	75	742	IE3-	93.8	94.2	93.8	0.81	142	7.0	1.9	1.7	2.3	5.55	1120
IE3-W41R 315 MX8	90	1157	90	743	IE3-	94.3	94.4	93.6	0.8	172	7.9	2.4	2.0	2.7	6	1185
IE3-W41R 315 MY8	110	1419	110	740	IE3-	93.8	94.0	93.8	0.82	206	6.5	1.9	1.5	2.1	6.76	1250
IE3-W41R 315 L8	132	1703	132	740	IE3-	94.2	94.2	93.5	0.8	253	8.0	2.4	1.9	2.7	8.71	1450
IE3-W41R 355 MY8	160	2051	160	745	IE3-	94.3	94.3	94.0	0.82	299	6.6	1.2	1.0	2.6	9.3	1700
IE3-W41R 355 M8	200	2564	200	745	IE3-	94.7	94.9	94.2	0.81	376	7.0	1.0	1.0	2.7	9.5	1890

*** upon request

Three-phase motors with squirrel-cage rotor, High Efficiency IE2 for converter-fed operation without filter up to 420 V



with surface cooling, duty type S8, S9
for rated voltage, thermal class 155 (F), degree of protection IP 55, 50 Hz

Motor selection data														Design point 400 V, 50 Hz		
Type	P _B	M _B	P _B	η _B	η _B			cosφ _B	I _B	I _K /I _B	M _K /M _B	M _G /M _B	M _K /M _B	J	m	
	Converter		Mains	rpm	(IEC/EN 60034-2)			-	400 V	-	-	-	-	kgm ²	kg	
	kW	Nm	kW		100 %	75 %	50 %		A							
Synchronous speed 3000 rpm – 2-pole version																
IE2-WE2R 56 G2	0.12	0.40	0.12	2830	IE2-	53.6	69.6	60.8	0.77	0.32	4.5	2.1	2.1	2.3	0.00013	4.5
IE2-WE2R 63 K2	0.18	0.62	0.18	2790	IE2-	60.4	63.1	57.6	0.76	0.51	4.1	1.9	1.9	2.2	0.00013	4.9
IE2-WE2R 63 G2	0.25	0.86	0.25	2775	IE2-	64.8	66.7	61.9	0.8	0.67	4.2	1.9	1.9	2.2	0.00015	5.2
IE2-WE2R 71 K2	0.37	1.28	0.37	2750	IE2-	69.5	70.8	69.4	0.84	0.89	4.6	1.8	1.8	2.1	0.00025	6.7
IE2-WE2R 71 G2	0.55	1.89	0.55	2775	IE2-	74.1	75.0	72	0.81	1.32	5.1	2.3	2.1	2.6	0.00032	7.6
IE2-WE2R 80 K2	0.75	2.54	0.75	2825	IE2-	77.4	77.1	72.9	0.81	1.72	5.9	2.4	2.4	2.4	0.00057	10.7
IE2-WE2R 80 G2	1.1	3.75	1.1	2805	IE2-	79.6	78.7	76.4	0.85	2.36	5.6	1.9	1.8	2.2	0.00072	11.5
IE2-WE2R 90 S2	1.5	4.99	1.5	2870	IE2-	81.3	82.0	79.4	0.8	3.30	6.6	3.2	3.2	3.7	0.00132	16
IE2-WE2R 90 L2	2.2	7.37	2.2	2850	IE2-	83.2	83.0	81.6	0.85	4.55	7.5	2.8	2.3	2.9	0.0017	19.0
IE2-WE2R 100 LY2	3	9.97	3	2875	IE2-	84.6	85.1	83.6	0.85	6	7.4	2.6	2.3	3.3	0.0045	28.5
IE2-WE1R 112 M2	4	13.20	4	2900	IE2-	85.8	85.9	84.8	0.81	8.4	7	2.2	2.1	2.9	0.0045	32.0
IE2-WE1R 132 SY2T	5.5	18.20	5.5	2890	IE2-	87.0	86.2	86.4	0.84	11	7.2	2.1	1.7	2.8	0.0055	40.0
IE2-WE1R 132 SX2T	7.5	24.90	7.5	2880	IE2-	88.1	88.4	87.8	0.84	14.8	6.3	1.5	1.2	2.6	0.0068	48.0
IE2-WE1R 132 SX2	7.5	24.5	7.5	2925	IE2-	88.8	89.2	88.3	0.91	13.5	6.7	2.1	1.6	2.9	0.0168	75
IE2-WE1R 160 M2	11.0	35.6	11.0	2950	IE2-	90.3	90.3	89.1	0.90	19.5	7.7	2.3	1.7	3.1	0.0258	125
IE2-WE1R 160 MX2	15.0	48.7	15.0	2940	IE2-	90.7	90.5	89.1	0.92	26	6.7	1.8	1.4	2.6	0.0675	140
IE2-WE1R 160 L2	18.5	60.2	18.5	2935	IE2-	91.0	91.4	91.4	0.91	32	7.2	2.0	1.5	2.8	0.0675	140
IE2-WE1R 180 M2	22	71.6	22	2935	IE2-	91.3	90.6	86.4	0.90	38.5	6.2	1.4	1.1	2.4	0.105	173
IE2-WE1R 200 L2	30	97	30	2945	IE2-	92.0	91.3	90.5	0.91	52	6.9	1.7	1.3	2.6	0.128	210
IE2-WE1R 200 LX2	37	120	37	2940	IE2-	92.5	92.3	91.6	0.92	63	7.4	1.9	1.4	2.9	0.154	233
IE2-WE2R 200 LX2	37	120	37	2940	IE2-	92.5	92.3	91.6	0.92	63	7.4	1.9	1.4	2.9	0.154	233
IE2-WE1R 225 M2	45	146	45	2950	IE2-	92.9	92.2	91.2	0.87	80.5	6.9	1.7	1.1	2.7	0.220	295
IE2-WE1R 250 M2	55	178	55	2955	IE2-	93.5	93.7	93.2	0.89	95.5	8.2	2.3	1.9	2.8	0.375	385
IE2-WE1R 280 S2	75	241	75	2970	IE2-	94.1	94.0	91.5	0.90	128	7.9	2.1	1.7	3.0	0.65	500
IE2-WE1R 280 M2	90	289	90	2970	IE2-	94.4	94.1	91.9	0.91	151	7.7	2.0	1.7	2.8	0.68	550
IE2-WE1R 315 S2	110	353	110	2975	IE2-	94.5	94.3	93.3	0.89	189	8.0	1.3	1.2	2.4	1.21	730
IE2-WE1R 315 M2	132	424	132	2975	IE2-	95.0	94.8	94.5	0.89	225	9.2	1.4	1.2	2.4	1.44	820
IE2-WE1R 315 MX2	160	514	160	2973	IE2-	94.8	94.8	94.8	0.89	274	8.2	1.3	1.3	2.4	1.76	955
IE2-WE1R 315 MY2	200	640	200	2983	IE2-	95.4	95.0	94.3	0.88	344	9.4	2.8	2.0	3.0	2.82	1200
IE2-WE1R 315 L2	220	704	250	2984	IE2-	95.4	95.4	95.4	0.92	411	9.0	2.3	1.2	2.3	3.66	1450
IE2-WE1R 315 LX2	270	864	315	2985	IE2-	95.4	95.4	95.0	0.92	518	8.5	2.8	1.6	2.5	4.43	1700
IE2-WE2R 355 M2	330	1056	355	2985	IE2-	95.5	95.5	95.5	0.92	583	7.7	1.3	1.0	2.6	4.20	2000
IE2-WE2R 355 MX2	355	1134	400	2990	IE2-	95.5	95.5	95.5	0.91	664	9.4	1.8	1.0	3.0	4.50	2200
IE2-WE2R 355 LY2	425	1360	450	2985	IE2-	95.5	95.5	95.5	0.92	739	7.0	1.3	0.9	2.4	7.10	2400
IE2-WE2R 355 L2	425	1360	500	2985	IE2-	95.5	95.5	95.5	0.92	821	8.5	1.5	1.2	2.5	7.10	2400

Three-phase motors with squirrel-cage rotor, High Efficiency IE2 for converter-fed operation without filter up to 420 V

IE2 EU REGULATION 640/2009
USE WITH VARIABLE SPEED DRIVE ONLY!

with surface cooling, duty type S8, S9
for rated voltage, thermal class 155 (F), degree of protection IP 55, 50 Hz

Motor selection data														Design point 400 V, 50 Hz		
Type	P _B	M _B	P _B	n _B	η _B			cosφ _B	I _B	I _A /I _B	M _A /M _B	M _G /M _B	M _K /M _B	J	m	
	Converter kW	Nm	Mains kW	rpm	IEC/EN 60034-2 100 % 75 % 50 %			-	400 V A	-	-	-	-	kgm ²	kg	
Synchronous speed 1500 rpm – 4-pole version																
IE2-WE2R 63 K4	0.12	0.83	0.12	1380	IE2-	59.1	55.7	46.8	0.69	0.45	2.8	1.6	1.6	2.1	0.00019	4.8
IE2-WE1R 63 GY4	0.18	1.23	0.18	1395	IE2-	64.7	66.3	61.3	0.72	0.54	3.5	1.7	1.7	2.2	0.0004	6.3
IE2-WE2R 71 K4	0.25	1.71	0.25	1395	IE2-	68.5	68.1	63.8	0.70	0.73	3.9	2.1	2.1	2.5	0.0005	7.8
IE2-WE1R 71 GY4	0.37	2.48	0.37	1425	IE2-	72.7	72.2	68.6	0.69	1.00	4.9	2.4	2.4	3.0	0.00087	9.9
IE2-WE2R 80 K4	0.55	3.71	0.55	1415	IE2-	77.1	77.1	73.9	0.72	1.42	4.9	2.6	2.5	2.8	0.00107	11.7
IE2-WE1R 80 GY4	0.75	5.01	0.75	1430	IE2-	79.6	78.0	74.7	0.80	1.73	5.7	2.2	2.2	3.1	0.00207	14.5
IE2-WE2R 90 S4	1.1	7.32	1.1	1435	IE2-	81.4	80.1	77.0	0.76	2.60	6.3	3.0	3.0	3.8	0.0028	18.5
IE2-WE1R 90 LW4	1.5	9.95	1.5	1440	IE2-	82.8	83.8	81.4	0.76	3.40	6.5	2.7	2.7	3.6	0.004	23
IE2-WE1R 100 S4	2.2	14.5	2.2	1445	IE2-	84.3	84.9	82.7	0.79	4.67	7.3	2.7	2.5	3.1	0.00725	30
IE2-WE1R 100 LW4	3.0	19.8	3.0	1445	IE2-	85.5	85.8	83.6	0.79	6.33	7.8	3.0	2.9	3.6	0.009	36
IE2-WE1R 112 MZ4	4.0	26.4	4.0	1445	IE2-	86.6	86.8	84.9	0.80	8.30	8.2	2.8	2.6	3.6	0.013	50
IE2-WE2R 132 SY4	5.5	36.2	5.5	1450	IE2-	87.7	87.7	86.4	0.84	10.80	8.0	2.5	2.3	3.8	0.015	58
IE2-WE1R 132 S4	5.5	35.7	5.5	1470	IE2-	89.8	89.9	88.4	0.87	10	7.4	2.3	1.9	3.4	0.035	87
IE2-WE1R 132 M4	7.5	48.7	7.5	1470	IE2-	89.9	90.0	88.5	0.82	14.5	8.5	2.6	2.1	4.0	0.035	88
IE2-WE1R 160 M4	11.0	71.2	11.0	1475	IE2-	90.6	90.3	88.5	0.82	21.5	8.1	3.1	2.4	3.4	0.078	122
IE2-WE2R 160 M4	11	71.5	11	1470	IE2-	90.3	90.3	88.5	0.78	22.5	7.8	2.4	2.1	3.9	0.043	105
IE2-WE1R 160 L4	15.0	97	15.0	1470	IE2-	90.6	90.9	90.5	0.87	27.5	8.3	2.7	2.2	3.2	0.115	160
IE2-WE2R 160 L4	15	97	15	1480	IE2-	92.0	92.0	90.6	0.84	28	9.1	3.0	2.5	3.9	0.115	161
IE2-WE1R 180 M4	18.5	120	18.5	1475	IE2-	91.5	91.5	90.4	0.86	34	6.8	1.8	1.5	2.7	0.168	207
IE2-WE2R 180 M4	18.5	120	18.5	1470	IE2-	91.2	90.6	89.3	0.78	37.5	6.4	2.0	1.6	2.8	0.138	176
IE2-WE1R 180 L4	22	142	22	1475	IE2-	91.6	91.4	89.9	0.83	42	7.3	2.1	1.7	3.0	0.168	215
IE2-WE1R 200 L4	30	194	30	1480	IE2-	92.3	91.3	88.2	0.80	58.5	7.3	2.1	1.7	2.9	0.275	277
IE2-WE1R 225 S4	37	240	37	1475	IE2-	92.7	91.8	90.7	0.84	68.5	7.4	2.2	1.7	2.7	0.313	313
IE2-WE1R 225 M4	45	290	45	1483	IE2-	93.1	93.0	91.1	0.84	83	7.9	2.3	1.9	2.4	0.525	390
IE2-WE2R 225 M4	45	291	45	1475	IE2-	93.1	92.9	92.1	0.80	87	7.6	2.6	1.9	3.1	0.356	346
IE2-WE1R 250 M4	55	354	55	1485	IE2-	94.0	94.1	92.5	0.84	101	8.0	2.0	1.7	2.3	0.95	535
IE2-WE2R 250 M4	55	356	55	1477	IE2-	93.9	93.8	93.7	0.82	103	7.5	2.4	1.9	2.4	0.62	435
IE2-WE1R 280 S4	75	482	75	1485	IE2-	94.2	94.4	92.1	0.84	137	7.2	1.8	1.6	2.1	0.95	550
IE2-WE1R 280 M4	90	580	90	1483	IE2-	94.3	94.5	94.0	0.84	164	7.6	1.8	1.6	2.3	1.10	610
IE2-WE1R 315 S4	110	707	110	1485	IE2-	94.8	94.8	94.0	0.82	204	8.5	1.8	1.5	2.7	1.96	760
IE2-WE1R 315 M4	132	849	132	1484	IE2-	95.0	95.0	94.5	0.83	242	8.2	1.8	1.6	2.3	2.27	850
IE2-WE1R 315 MX4	160	1031	160	1482	IE2-	95.0	95.0	94.5	0.84	289	7.4	1.6	1.4	2.2	2.73	975
IE2-WE1R 315 MY4	200	1282	200	1490	IE2-	95.1	95.1	94.5	0.87	349	8.5	1.8	1.6	2.5	4.82	1270
IE2-WE1R 315 L4	250	1602	250	1490	IE2-	95.4	95.4	95.3	0.88	430	9.0	2.2	1.5	2.7	5.93	1450
IE2-WE1R 315 LX4	285	1827	315	1490	IE2-	95.4	95.4	95.0	0.88	542	9.0	2.4	1.6	2.6	6.82	1630
IE2-WE2R 355 M4	355	2271	355	1493	IE2-	95.5	95.5	95.0	0.87	617	8.0	1.3	1.0	2.7	7.90	2150
IE2-WE2R 355 MX4	390	2493	400	1494	IE2-	95.5	95.5	95.5	0.88	687	8.5	1.3	1.0	3.0	9.50	2400
IE2-WE2R 355 LY4	430	2745	450	1496	IE2-	95.5	95.5	95.5	0.86	791	8.5	1.4	0.8	2.9	10.00	2500
IE2-WE2R 355 L4	430	2745	500	1496	IE2-	95.5	95.5	95.5	0.84	900	8.0	1.2	0.9	3.0	10.00	2500

Three-phase motors with squirrel-cage rotor, High Efficiency IE2 for converter-fed operation without filter up to 420 V



with surface cooling, duty type S8, S9
for rated voltage, thermal class 155 (F), degree of protection IP 55, 50 Hz

Motor selection data														Design point 400 V, 50 Hz		
Type	P _B	M _B	P _B	η _B	η _B			cosφ _B	I _B	I _A /I _B	M _A /M _B	M _G /M _B	M _K /M _B	J	m	
	Converter		Mains	rpm	(IEC/EN 60034-2)			-	400 V	-	-	-	-	kgm ²	kg	
	KW	Nm	KW		100 %	75 %	50 %		A							
Synchronous speed 1000 rpm – 6-pole version																
IE2-WE2R 63 G6	0.12	1.3	0.12	880	IE2-	50.6	47.0	39.5	0.59	0.59	2.6	2.1	2.1	2.3	0.00027	5.7
IE2-WE2R 71 K6	0.18	1.9	0.18	920	IE2-	56.6	54.4	48.5	0.52	0.8	2.9	2.0	2.0	2.3	0.0006	8.3
IE2-WE2R 71 G6	0.25	2.6	0.25	915	IE2-	61.6	57.5	51.6	0.55	1.1	2.9	2.0	2.0	2.2	0.0006	8.3
IE2-WE2R 80 K6	0.37	3.8	0.37	935	IE2-	67.6	68.5	63.3	0.65	1.17	3.7	2.1	2.1	2.6	0.00175	12.5
IE2-WE1R 80 GY6	0.55	5.6	0.55	945	IE2-	73.1	72.6	68.4	0.67	1.6	3.8	1.9	1.9	2.4	0.00325	15.0
IE2-WE2R 90 S6	0.75	7.6	0.75	945	IE2-	75.9	75.5	72.1	0.67	2.12	4.0	1.8	1.8	2.4	0.00425	19.0
IE2-WE1R 90 LW6	1.1	11.0	1.1	955	IE2-	78.1	78.0	75.1	0.69	2.95	4.7	2.5	2.4	2.8	0.00625	24.0
IE2-WE2R 100 L6	1.5	15.1	1.5	950	IE2-	79.8	80.4	77.6	0.7	3.85	5.1	2.5	2.4	3.0	0.0072	30.0
IE2-WE1R 112 MX6	2.2	21.9	2.2	960	IE2-	81.8	81.9	77.5	0.65	5.9	6.4	3.0	2.9	3.7	0.0139	37.0
IE2-WE1R 132 S6	3.0	29.8	3.0	963	IE2-	84.9	85.2	83.9	0.80	6.4	6.0	2.0	1.3	3.0	0.023	55
IE2-WE2R 132 M6	4.0	40	4.0	955	IE2-	85.1	86.0	85.2	0.82	8.3	5.7	2.1	2.0	2.9	0.029	66
IE2-WE1R 132 M6	4.0	39.6	4.0	965	IE2-	85.5	85.5	83.8	0.79	8.5	5.1	1.8	1.6	2.4	0.043	76
IE2-WE1R 132 MX6	5.5	54.1	5.5	970	IE2-	86.1	85.5	82.4	0.77	12	5.7	2.2	1.7	2.7	0.053	85
IE2-WE1R 160 M6	7.5	73	7.5	975	IE2-	87.4	88.1	86.0	0.81	15.5	6.3	2.5	2.1	2.9	0.113	118
IE2-WE2R 160 M6	7.5	74	7.5	970	IE2-	87.5	87.6	85.9	0.79	15.5	5.9	2.1	1.8	2.9	0.053	103
IE2-WE1R 160 L6	11.0	108	11.0	970	IE2-	88.7	87.9	86.3	0.85	21	5.8	2.2	1.9	2.7	0.145	135
IE2-WE2R 160 L6	11.0	108	11.0	975	IE2-	88.9	88.8	87.0	0.81	22	6.8	2.7	2.4	3.1	0.166	155
IE2-WE1R 180 L6	15.0	147	15.0	975	IE2-	89.7	88.8	86.7	0.84	28.5	6.2	2.1	1.8	2.8	0.228	185
IE2-WE2R 180 L6	15	148	15	970	IE2-	89.7	88.8	87.8	0.83	29	5.6	2.3	1.7	2.6	0.166	157
IE2-WE1R 200 L6	18.5	180	18.5	980	IE2-	90.4	88.8	86.5	0.85	35	6.6	2.3	1.7	2.9	0.268	208
IE2-WE1R 200 LX6	22	214	22	980	IE2-	90.9	90.2	88.5	0.86	40.5	6.4	2.2	1.8	2.7	0.443	272
IE2-WE2R 200 LX6	22	215	22	975	IE2-	90.9	89.9	88.5	0.84	41.5	6.7	2.4	2.0	3.0	0.324	238
IE2-WE1R 225 M6	30	291	30	985	IE2-	92.0	91.5	90.0	0.86	54.5	7.3	2.5	2.2	2.9	0.825	365
IE2-WE2R 225 M6	30	294	30	975	IE2-	91.7	91.4	90.6	0.87	54.5	6.7	2.3	1.9	2.8	0.514	308
IE2-WE1R 250 M6	37	359	37	985	IE2-	92.2	91.7	90.7	0.85	68	6.4	2.7	1.8	2.4	1.28	480
IE2-WE2R 250 M6	37	361	37	979	IE2-	92.2	92.3	91.8	0.86	67.5	6.6	2.7	2.0	2.6	0.92	407
IE2-WE1R 280 S6	45	437	45	983	IE2-	93.0	92.7	92.4	0.87	80.5	6.5	2.2	1.7	2.4	1.48	560
IE2-WE1R 280 M6	55	531	55	990	IE2-	93.5	93.5	93.0	0.85	100	7.6	2.0	1.5	2.5	2.63	710
IE2-WE1R 315 S6	75	723	75	990	IE2-	93.9	93.7	93.5	0.87	133	7.8	1.9	1.5	2.5	3.33	804
IE2-WE1R 315 M6	90	868	90	990	IE2-	94.0	94.0	93.5	0.88	157	7.5	1.8	1.5	2.5	3.60	865
IE2-WE1R 315 MX6	110	1061	110	990	IE2-	94.3	94.3	94.0	0.87	194	7.5	1.8	1.4	2.3	6.67	1210
IE2-WE1R 315 MY6	132	1273	132	990	IE2-	94.6	94.3	94.0	0.87	231	7.5	1.9	1.4	2.2	6.67	1250
IE2-WE1R 315 L6	160	1543	160	990	IE2-	94.8	94.5	93.5	0.88	277	7.5	2.0	1.5	2.4	8.60	1430
IE2-WE1R 315 LX6	185	1785	200	990	IE2-	95.0	95.0	94.5	0.86	353	7.0	1.9	1.5	2.2	8.60	1460
IE2-WE2R 355 M6	250	2402	250	994	IE2-	95.0	95.0	94.7	0.84	452	7.0	1.5	1.2	2.2	8.20	1850
IE2-WE2R 355 MX6	300	2879	315	995	IE2-	95.2	95.2	95.2	0.86	555	7.0	1.3	1.1	2.2	12.1	2200
IE2-WE2R 355 LY6	315	3023	355	995	IE2-	95.0	95.0	94.0	0.77	700	7.5	1.8	1.5	2.6	14.0	2400

Three-phase motors with squirrel-cage rotor, High Efficiency IE2 for converter-fed operation without filter up to 420 V

with surface cooling, duty type S8, S9
for rated voltage, thermal class 155 (F), degree of protection IP 55, 50 Hz

Motor selection data														Design point 400 V, 50 Hz		
Type	P_B	M_B	P_B	n_B	η_B			$\cos\varphi_B$	I_B	I_A/I_B	M_A/M_B	M_S/M_B	M_K/M_B	J	m	
	Converter		Mains	rpm	(IEC/EN 60034-2)			-	400 V	-	-	-	-	kgm ²	kg	
	kW	Nm	kW		100 %	75 %	50 %		A							
Synchronous speed 750 rpm – 8-pole version																
IE2-WE2R 71 G8	0.12	1.7	0.12	670	IE2-	39.8	39.8	31.9	0.54	0.73	2.10	1.80	1.80	2.00	0.0006	8
IE2-WE2R 80 K8	0.18	2.5	0.18	690	IE2-	45.9	52.2	44.0	0.59	0.78	2.70	1.90	1.90	2.20	0.0013	11
IE2-WE2R 80 G8	0.25	3.4	0.25	695	IE2-	50.6	50.4	42.5	0.56	1.12	3.00	2.30	2.30	2.50	0.00175	12
IE2-WE2R 90 S8	0.37	5.1	0.37	700	IE2-	56.1	57.3	50.7	0.54	1.60	3.00	1.50	1.50	2.00	0.003	15
IE2-WE2R 90 L8	0.55	7.6	0.55	695	IE2-	61.7	61.3	54.9	0.60	2.04	3.30	1.50	1.50	2.00	0.00375	18
IE2-WE2R 100 L8	0.75	10.2	0.75	705	IE2-	66.2	64.5	58.7	0.60	2.90	3.10	1.50	1.50	2.00	0.00625	23
IE2-WE1R 100 LY8	1.1	14.9	1.1	705	IE2-	70.8	71.2	67.6	0.67	3.25	4.00	2.00	2.00	2.40	0.009	28
IE2-WE1R 112 M8	1.5	20.3	1.5	705	IE2-	74.1	73.6	70.1	0.62	4.50	4.20	2.00	2.00	2.70	0.0139	37
IE2-WE1R 132 S8	2.2	29.2	2.2	720	IE2-	81.7	81.0	77.5	0.65	6	4.8	2.2	2.0	3.2	0.0180	55
IE2-WE2R 132 M8	3.0	40.4	3.0	710	IE2-	80.0	80.8	79.0	0.73	7.4	4.9	1.9	1.9	2.7	0.0290	65
IE2-WE1R 132 M8	3.0	39.8	3.0	720	IE2-	82.7	83.0	81.3	0.74	7.1	3.9	1.6	1.3	1.9	0.0430	74
IE2-WE1R 160 M8	4.0	53.2	4.0	718	IE2-	84.2	83.7	81.9	0.72	9.5	4.6	1.6	***)	2.5	0.0530	86
IE2-WE1R 160 MX8	5.5	72	5.5	730	IE2-	86.9	86.6	84.1	0.72	12.5	4.8	2.1	1.8	2.6	0.1130	115
IE2-WE2R 160 MX8	5.5	73	5.5	715	IE2-	83.9	84.0	81.9	0.71	13.5	4.3	1.7	1.5	2.5	0.0530	103
IE2-WE1R 160 L8	7.5	99	7.5	725	IE2-	86.9	87.6	86.6	0.76	16.5	4.5	1.8	1.6	2.3	0.1450	138
IE2-WE1R 180 L8	11.0	144	11.0	727	IE2-	88.2	88.2	86.7	0.78	23	4.9	1.8	1.6	2.4	0.2280	175
IE2-WE2R 180 L8	11	144	11	730	IE2-	87.9	87.4	85.2	0.67	25.5	4.3	1.9	1.6	2.3	0.1660	157
IE2-WE1R 200 L8	15.0	197	15.0	727	IE2-	88.2	88.1	86.4	0.77	32	4.9	1.9	1.7	2.3	0.2680	200
IE2-WE1R 225 S8	18.5	242	18.5	730	IE2-	89.6	89.4	87.2	0.78	38	5.4	2.1	2.0	2.8	0.440	265
IE2-WE2R 225 S8	18.5	240	18.5	735	IE2-	90.7	90.7	89.4	0.8	37	6.1	2.1	1.9	2.9	0.514	305
IE2-WE1R 225 M8	22	287	22	733	IE2-	90.6	89.4	89.9	0.78	45	5.6	2.2	1.8	2.6	0.825	380
IE2-WE2R 225 M8	22	286	22	735	IE2-	90.3	90.3	88.7	0.77	45.5	6.1	2.2	2.0	2.9	0.514	307
IE2-WE1R 250 M8	30	391	30	732	IE2-	90.8	91.0	90.0	0.78	61	5.6	2.2	1.9	2.4	0.830	380
IE2-WE1R 280 S8	37	479	37	737	IE2-	90.8	91.3	90.7	0.80	73.5	4.9	1.9	1.5	2.0	1.35	480
IE2-WE1R 280 M8	45	581	45	740	IE2-	91.8	91.8	90.7	0.77	92	5.8	2.3	1.8	2.5	1.55	535
IE2-WE1R 315 S8	55	710	55	740	IE2-	92.2	92.2	92.2	0.80	108	6.3	1.8	1.5	2.3	2.63	715
IE2-WE1R 315 M8	75	968	75	740	IE2-	92.7	92.5	92.5	0.81	144	6.0	2.1	1.4	2.1	3.33	805
IE2-WE1R 315 MX8	90	1161	90	740	IE2-	93.0	93.0	93.0	0.79	177	6.5	1.7	1.5	2.2	3.6	850
IE2-WE1R 315 MY8	110	1420	110	740	IE2-	93.4	93.4	93.4	0.82	207	6.5	1.8	1.6	2.2	6	1080
IE2-WE1R 315 L8	132	1704	132	740	IE2-	93.2	93.2	93.2	0.83	246	6.0	1.5	1.4	2.2	6.76	1250
IE2-WE1R 315 LX8	145	1871	160	740	IE2-	93.9	93.9	93.8	0.80	307	7.2	2.2	1.8	2.5	8.71	1430
IE2-WE2R 355 M8	200	2571	200	743	IE2-	94.5	94.1	91.5	0.77	397	***)	***)	***)	***)	9.5	1850
IE2-WE2R 355 MX8	225	2884	250	745	IE2-	94.0	94.0	94.0	0.83	463	7.0	1.2	1.0	2.6	13.4	2200
IE2-WE2R 355 LY8	230	2956	280	743	IE2-	94.3	94.3	94.3	0.78	549	7.2	1.3	1.0	2.7	15.8	2400

***) upon request

Three-phase motors with squirrel-cage rotor
Standard insulation for converter-fed operation without filter up to 420 V



with surface cooling, duty type S8, S9
 for rated voltage, thermal class 155 (F), degree of protection IP 55, 50 Hz

Motor selection data												Design point 400 V, 50 Hz	
Type IEC/DIN	Type Progressive	P _B	M _B	n _B	η _B	cosφ _B	I _B	I _M /I _B	M _K /M _B	M _S /M _B	M _R /M _B	J	m
		kW	Nm	rpm	%	-	A	-	-	-	-	kgm ²	kg
(IEC/EN 60034-2) 400 V													
Synchronous speed 3000 rpm – 2-pole version													
K210 56 K2		0.09	0.3	2840	70	0.74	0.25	4.9	2.3	2.3	2.8	0.00013	4.4
K21R 56 G2		0.12	0.4	2830	70.3	0.77	0.32	4.5	2.1	2.1	2.3	0.00013	4.5
K21R 63 K2	K20R 56 K2	0.18	0.62	2790	67	0.76	0.51	4.1	1.9	1.9	2.2	0.00013	4.9
K21R 63 G2	K20R 56 G2	0.25	0.85	2800	67.7	0.72	0.74	4.2	2.2	2.2	2.4	0.00015	5.2
K21R 71 K2	K20R 63 K2	0.37	1.27	2780	71.9	0.79	0.94	4.4	2.1	2.1	2.3	0.00025	6.7
K21R 71 G2	K20R 63 G2	0.55	1.89	2775	74.2	0.81	1.32	5.1	2.3	2.1	2.6	0.00032	7.6
K21R 80 K2	K20R 71 K2	0.75	2.54	2825	77.7	0.81	1.72	5.9	2.4	2.4	2.4	0.00057	10.7
K21R 80 G2	K20R 71 G2	1.1	3.71	2835	77.8	0.8	2.55	6	2.4	2.3	2.6	0.00072	11.5
K21R 90 S2	K20R 80 K2	1.5	5.04	2840	81.2	0.86	3.1	7	2.5	2.5	2.8	0.00132	16
K21R 90 L2	K20R 80 G2	2.2	7.37	2850	82.1	0.85	4.55	7.5	2.8	2.3	2.9	0.0017	19
K21R 100 L2	K20R 90 L2	3	10	2865	83.8	0.84	6.15	6.8	2.4	2.2	2.8	0.00275	25
K21R 112 M2	K20R 100 S2	4	13.2	2900	84.9	0.81	8.4	7	2.2	2.1	2.9	0.0045	32
K21R 112 MX2	K20R 100 L2	5.5	18.2	2890	85.9	0.84	11	7.5	2.4	2.2	3	0.0055	38
K21R 132 S2T	K20R 100 L2	5.5	18.2	2890	85.9	0.84	11	7.5	2.4	2.2	3	0.0055	40
K21R 112 MV2	K20R 100 LV2	7.5	24.9	2880	87.1	0.84	14.8	6.3	1.5	1.2	2.6	0.0068	46
K21R 132 SX2T	K20R 100 LV2	7.5	24.9	2880	87.1	0.84	14.8	6.3	1.5	1.2	2.6	0.0068	48
K21R 132 S2	K20R 112 MY2	5.5	18.4	2860	85.7	0.86	11	5.5	1.8	1.6	2.2	0.0081	52
K21R 132 SX2	K20R 112 M2	7.5	24.7	2900	87	0.86	14.5	6.6	1.8	1.3	2.5	0.011	57
K21R 160 M2	K20R 132 M2	11	36.2	2900	88.5	0.9	20	7	2.4	2	3	0.0258	81
K21R 160 MX2	K20R 160 S2	15	48.9	2930	89.4	0.9	27	7.1	2.2	1.7	2.9	0.0575	118
K21R 160 L2	K20R 160 M2	18.5	61	2920	90.5	0.92	32	7.2	2.1	1.6	2.8	0.0675	134
K21R 180 M2	K20R 180 S2	22	72	2935	91.8	0.92	37.5	6.8	1.7	1.4	2.6	0.105	165
K21R 200 L2	K20R 180 M2	30	97	2940	92.8	0.92	50.5	7.3	2	1.6	2.9	0.128	195
K21R 200 LX2	K20R 200 M2	37	120	2940	93	0.9	64	7	1.8	1.3	2.4	0.193	255
K21R 225 M2	K20R 200 L2	45	146	2940	93.7	0.91	76	7.5	1.8	1.4	2.7	0.22	290
K21R 250 M2	K20R 225 M2	55	178	2955	93.7	0.91	93	7.5	2	1.5	2.6	0.375	360
K21R 280 S2	K20R 250 S2	75	241	2970	94.6	0.92	124	7.5	2	1.6	2.6	0.65	490
K21R 280 M2	K20R 250 M2	90	289	2970	94.7	0.91	151	8.5	2.2	1.8	2.8	0.675	510
K21R 315 S2	K20R 280 S2	110	353	2975	95.4	0.91	183	8.5	1.5	1.3	2.5	1.21	720
K21R 315 M2	K20R 280 M2	132	424	2975	95.4	0.91	219	8.5	2	1.8	2.7	1.44	800
K21R 315 MX2	K20R 315 S2	160	514	2975	96	0.93	259	8.5	2	1.6	2.6	1.76	980
K21R 315 MY2	K20R 315 M2	200	643	2970	96	0.92	327	8.2	2.6	2	2.6	2.82	1170
K21R 315 L2	K20R 315 L2	250	803	2973	96.1	0.93	404	7.3	2.1	1.4	2	3.66	1460
K21R 315 LX2	K20R 315 LX2	315	1011	2975	96.7	0.92	511	7.4	2.4	1.4	2	4.43	1630
K22R 355 MY2		315	1007	2988	96.8	0.88	534	8.6	1.25	1	3	4.1	1900
K22R 355 M2		355	1138	2980	96.5	0.91	583	7.3	1.3	1	2.3	4.2	2000
K22R 355 MX2		400	1280	2985	96.8	0.9	663	8.5	1.9	1.3	3.2	5.5	2200
K22R 355 LY2		450	1441	2983	96.9	0.92	729	7.2	1.3	1	2.4	7.1	2400
K22R 355 L2		500	1600	2985	97.2	0.92	807	8.2	1.75	0.9	2.6	7.1	2400

Motor selection data

Type IEC/DIN	Type Progressive	Converter input, 50 Hz			Setting range 1 : 2.5			Setting range 1 : 5			Setting range 1 : 10			I ₀ kW	I _{max} A	M _{max} Nm	n _{max} rpm	n _{maxFU} rpm
		P _{50 Hz} kW	i _B A	M _B Nm	P _{1:2.5} kW	i _B A	M _B Nm	P _{1:5} kW	i _B A	M _B Nm	P _{1:10} kW	i _B A	M _B Nm					
Synchronous speed 3000 rpm – 2-pole version																		
K210 56 K2		0.09	0.25	0.3													15000	5220
K21R 56 G2		0.12	0.32	0.4													15000	5220
K21R 63 K2	K20R 56 K2	0.18	0.51	0.62	0.14		0.5	0.1	0.34	0.09		0.3				1	15000	5220
K21R 63 G2	K20R 56 G2	0.25	0.74	0.86	0.2		0.69	0.14	0.49	0.12		0.42				1.5	15000	5220
K21R 71 K2	K20R 63 K2	0.37	0.94	1.28	0.3		1.02	0.22	0.74	0.19		0.66				2.2	14000	5220
K21R 71 G2	K20R 63 G2	0.55	1.32	1.91	0.44		1.52	0.32	1.12	0.29		1				3.7	14000	5220
K21R 80 K2	K20R 71 K2	0.75	1.72	2.5	0.59		2	0.43	1.44	0.34		1.2				4.6	13000	5220
K21R 80 G2	K20R 71 G2	1.1	2.55	3.7	0.88		3	0.64	2.2	0.51		1.76				7.4	13000	5220
K21R 90 S2	K20R 80 K2	1.5	3.1	5	1.2		4	0.96	3.2	0.72		2.4				10	11000	5220
K21R 90 L2	K20R 80 G2	2.2	4.55	7.4	1.76		5.9	1.44	4.7	1.07		3.6				16	11000	5220
K21R 100 L2	K20R 90 L2	3	6.15	10	2.4		8	2	6.6	1.52		5.2				21	10000	5220
K21R 112 M2	K20R 100 S2	4	8.4	13.2	3.2		10.6	2.8	9.4	2.2		7				29	7000	5220
K21R 112 MX2	K20R 100 L2	5.5	11	18.20	5.5		18.1	4.7	15.5	3.9		13				41	7000	5220
K21R 132 S2T	K20R 100 L2	5.5	11	18.2	4.4		14.5	3.8	12.4	3.1		10.4				41	7000	5220
K21R 112 MV2	K20R 100 LV2	7.5	14.8	25.00	7.5		24.9	6.5	21.7	5.4		17.9				49	7000	5220
K21R 132 SX2T	K20R 100 LV2	7.5	14.8	25	6		19.9	5.2	17.4	4.3		14.3				49	7000	5220
K21R 132 S2	K20R 112 MY2	5.2	10.4	17.2	5.2	10.4	17.2	5.1	9.4	16.9	4.7	7.8	15.5	5.3	18.5	28	7000	5220
K21R 132 SX2	K20R 112 M2	7.5	14.5	24.8	7.5	14.1	24.8	7.5	13.7	24.8	6.6	11.6	21.8	5.9	28	43	7000	5220
K21R 160 M2	K20R 132 M2	10.5	19.5	35	10.5	19.5	35	10	18.2	33	8.4	15.3	28	6	47	76	6000	5220
K21R 160 MX2	K20R 160 S2	15	27	48.9	14.9	27	49	15	27	49.4	13.5	24.3	44.5	7.6	61	99	6000	5220
K21R 160 L2	K20R 160 M2	18.5	32	61	18.5	32	60.9	18.5	32	60.9	16.4	28.4	54	7.6	64	110	6000	5220
K21R 180 M2	K20R 180 S2	22	37.5	72	22	37.5	71.9	22	37.5	72.1	20.9	35.6	68.5	8.8	75	130	6000	5220
K21R 200 L2	K20R 180 M2	30	50.5	97	30	50.5	98	30	50.5	97.8	28.2	47.5	92	10.8	109	190	5000	5000
K21R 200 LX2	K20R 200 M2	37	64	120	37	64	120	37	64	120	35.4	61.5	115	14.5	118	200	5000	5000
K21R 225 M2	K20R 200 L2	45	76	146	45	76	146	45	76	146	42.2	71.5	137	18	155	270	5000	5000
K21R 250 M2	K20R 225 M2	55	93	178	55	93	178	55	93	178	51	86.5	165	23	185	320	4500	4500
K21R 280 S2	K20R 250 S2	74	122	238	74	122	238	74	123	238	69.5	115	224	30	244	430	4300	4300
K21R 280 M2	K20R 250 M2	87	146	280	87	146	280	87	146	280	80.7	135	260	36	322	560	4300	4300
K21R 315 S2	K20R 280 S2	110	183	353	110	183	354	110	183	354	110	183	354	36.5	348	610	3800	3800
K21R 315 M2	K20R 280 M2	132	219	424	132	219	424	132	219	424	132	219	424	40	455	800	3800	3800
K21R 315 MX2	K20R 315 S2	160	259	514	160	259	514	160	259	514	160	259	514	40	516	930	3600	3600
K21R 315 MY2	K20R 315 M2	192	314	616	192	314	616	192	314	616	192	314	616	65	655	1170	3600	3600
K21R 315 L2	K20R 315 L2	220	356	706	220	356	706	220	356	706	220	356	706	67	620	1120	3600	3600
K21R 315 LX2	K20R 315 LX2	270	438	867	270	438	867	270	438	867	270	438	867	50	784	1410	3600	3600
K22R 355 MY2		315	534	1007	315	534	1007	315	534	1007	297	503	950		1232	2110	3600	3600
K22R 355 M2		330	542	1058	330	542	1057	330	542	1057	306	503	980		1032	1830	3600	3600
K22R 355 MX2		355	588	1138	355	588	1138	355	588	1138	355	588	1138		1630	2860	3600	3600
K22R 355 LY2		380	620	1215	370	600	1186	370	600	1186	370	600	1186		1348	2420	3600	3600
K22R 355 L2		425	700	1360	370	600	1186	370	600	1186	370	600	1186		1615	2910	3600	3600

Three-phase motors with squirrel-cage rotor
Standard insulation for converter-fed operation without filter up to 420 V



with surface cooling, duty type S8, S9
 for rated voltage, thermal class 155 (F), degree of protection IP 55, 50 Hz

Motor selection data												Design point 400 V, 50 Hz	
Type IEC/DIN	Type Progressive	P _B	M _B	n _B	η _B	cosφ _B	I _B	I _A /I _B	M _A /M _B	M _S /M _B	M _K /M _B	J	m
		(IEC/EN 60034-2)				400 V							
		kW	Nm	rpm	%	-	A	-	-	-	-	kgm ²	kg
Synchronous speed 1500 rpm – 4-pole version													
K210 56 K4		0.06	0.41	1410	60.1	0.6	0.24	3.1	2.3	2.3	2.7	0.00019	4.3
K21R 56 G4		0.09	0.63	1375	61.6	0.68	0.31	3.2	1.9	1.9	2.2	0.00019	4.4
K21R 63 K4	K20R 56 K4	0.12	0.84	1370	57.9	0.68	0.44	3.2	1.9	1.8	2.2	0.00019	4.8
K21R 63 G4	K20R 56 G4	0.18	1.26	1360	60.6	0.66	0.65	3.3	2	2	2.3	0.00024	5.2
K21R 71 K4	K20R 63 K4	0.25	1.72	1385	64.3	0.72	0.78	3.6	1.8	1.8	2.1	0.0004	6.8
K21R 71 G4	K20R 63 G4	0.37	2.58	1370	68.1	0.74	1.06	3.8	2	2	2.2	0.0005	7.8
K21R 80 K4	K20R 71 K4	0.55	3.75	1400	71.9	0.69	1.6	4.1	2.1	2	2.3	0.00087	10.6
K21R 80 G4	K20R 71 G4	0.75	5.12	1400	73.6	0.7	2.1	4.6	2.2	2.1	2.3	0.00107	11.7
K21R 90 S4	K20R 80 K4	1.1	7.5	1410	76.7	0.79	2.62	5.5	2.3	2.2	2.5	0.00207	15.5
K21R 90 L4	K20R 80 G4	1.5	10.2	1400	78.6	0.81	3.4	5.5	2.5	2.4	2.6	0.0026	18
K21R 100 L4	K20R 90 L4	2.2	14.9	1410	81.2	0.79	4.95	6	2.5	2.3	2.7	0.004	23.5
K21R 100 LX4	K20R 100 S4	3	20	1430	82.4	0.79	6.65	6.5	2.5	2.2	2.9	0.00725	30
K21R 112 M4	K20R 100 L4	4	26.6	1435	84.1	0.78	8.8	6.9	2.6	2.5	3.2	0.009	37
K21R 112 MX4	K20R 100 LX4	5.5	36.9	1425	86.3	0.78	11.8	6.3	2.5	2.4	2.9	0.011	45
K21R 132 S4T	K20R 100 LX4	5.5	36.9	1425	86.3	0.78	11.8	6.3	2.5	2.4	2.9	0.011	47
K21R 132 S4	K20R 112 M4	5.5	36.5	1440	85.7	0.89	10.5	6.5	1.9	1.7	3	0.015	50
K21R 132 M4	K20R 132 S4	7.5	49.4	1450	87	0.84	15	6	2	1.7	2.9	0.028	70
K21R 160 M4	K20R 132 M4	11	72	1450	88.4	0.85	21	6.8	2.2	1.9	3.3	0.035	92
K21R 160 L4	K20R 160 S4	15	98	1465	89.4	0.86	28	7.3	2.5	2	3	0.078	120
K21R 180 M4	K20R 160 M4	18.5	121	1460	90	0.86	34.5	6.8	2.5	2	2.9	0.09	136
K21R 180 L4	K20R 180 S4	22	143	1465	90.5	0.84	42	6.5	2	1.8	2.6	0.138	170
K21R 200 L4	K20R 180 M4	30	196	1465	91.5	0.85	55.5	7	2	1.7	2.4	0.168	200
K21R 225 S4	K20R 200 M4	37	240	1470	92.5	0.86	67	7	2	1.7	2.5	0.275	270
K21R 225 M4	K20R 200 L4	45	292	1470	93	0.86	81	7	2	1.7	2.5	0.313	300
K21R 250 M4	K20R 225 M4	55	356	1475	93.5	0.86	98.5	7	2.2	1.7	2.3	0.525	375
K21R 280 S4	K20R 250 S4	75	484	1480	94.1	0.86	134	7	2	1.7	2.2	0.95	520
K21R 280 M4	K20R 250 M4	90	581	1480	94.6	0.86	160	7	2.1	1.6	2.2	1.1	580
K21R 315 S4	K20R 280 S4	110	707	1485	95.1	0.86	194	7.5	1.8	1.6	2.2	1.96	740
K21R 315 M4	K20R 280 M4	132	849	1485	95.1	0.86	233	7	1.8	1.5	2.2	2.27	840
K21R 315 MX4	K20R 315 S4	160	1032	1480	95	0.87	279	7	1.8	1.5	2	2.73	1000
K21R 315 MY4	K20R 315 M4	200	1286	1485	96	0.88	342	7.5	2	1.8	2.4	4.82	1200
K21R 315 L4	K20R 315 L4	250	1608	1485	96.1	0.9	417	8	2	1.6	2.3	5.93	1510
K21R 315 LX4	K20R 315 LX4	315	2019	1490	96.5	0.88	535	8.6	1.9	1.5	2.5	6.82	1630
K22R 355 MY4		315	2016	1492	95.6	0.85	560	7.1	1.4	1	2.9	5.6	1950
K22R 355 M4		355	2275	1490	96.8	0.84	630	8.1	1.8	1	3.1	7.9	2150
K22R 355 MX4		400	2557	1494	96.8	0.84	710	8.6	1.3	1	3	9.5	2400
K22R 355 LY4		450	2884	1490	96.8	0.82	818	8	1.2	1	3	10	2500
K22R 355 L4		500	3205	1490	96.7	0.79	945	7.9	1.1	1	3	10	2500

Motor selection data

Type IEC/DIN	Type Progressive	Converter input, 50 Hz			Setting range 1 : 2.5			Setting range 1 : 5			Setting range 1 : 10			I ₀ kW	I _{max} 400 V A	M _{max} Nm	n _{max} rpm	n _{maxFU} rpm
		P _{50 Hz}	i _B	M _B	P _{1:2.5}	i _B	M _B	P _{1:5}	i _B	M _B	P _{1:10}	i _B	M _B					
		kW	A	Nm	kW	A	Nm	kW	A	Nm	kW	A	Nm					
Synchronous speed 1500 rpm – 4-pole version																		
K210 56 K4		0.06	0.24	0.41												0.8	12000	2610
K21R 56 G4		0.09	0.31	0.63												1	12000	2610
K21R 63 K4	K20R 56 K4	0.12	0.44	0.84	0.1		0.66	0.06		0.41	0.05		0.32			1.4	12000	2610
K21R 63 G4	K20R 56 G4	0.18	0.65	1.27	0.14		1.01	0.09		0.62	0.07		0.49			2.2	12000	2610
K21R 71 K4	K20R 63 K4	0.25	0.78	1.76	0.19		1.38	0.13		0.91	0.1		0.67			2.7	11000	2610
K21R 71 G4	K20R 63 G4	0.37	1.06	2.62	0.29		2.1	0.19		1.36	0.14		1.01			4.3	11000	2610
K21R 80 K4	K20R 71 K4	0.55	1.6	3.7	0.44		3	0.35		2.4	0.2		1.36			6.6	11000	2610
K21R 80 G4	K20R 71 G4	0.75	2.1	5.1	0.6		4.1	0.49		3.3	0.27		1.88			9	11000	2610
K21R 90 S4	K20R 80 K4	1.1	2.62	7.5	0.88		5.9	0.7		4.7	0.44		3			14	9000	2610
K21R 90 L4	K20R 80 G4	1.5	3.4	10.2	1.2		8	0.94		6.4	0.6		4.1			20	9000	2610
K21R 100 L4	K20R 90 L4	2.2	4.95	14.9	1.76		11.9	1.39		9.4	1		6.8			30	8000	2610
K21R 100 LX4	K20R 100 S4	3	6.65	19.8	2.4		15.8	2.2		14.4	1.68		11.3			44	6000	2610
K21R 112 M4	K20R 100 L4	4	8.8	26.6	3.2		21.3	3		19.4	2.3		15.3			65	6000	2610
K21R 112 MX4	K20R 100 LX4	5.5	11.8	36.90	5.2		35.1	4.4		29.6	3.4		22.7			82	6000	2610
K21R 132 S4T	K20R 100 LX4	5.5	11.8	36.90	4.2		28.1	3.5		23.7	2.7		18.2			82	6000	2610
K21R 132 S4	K20R 112 M4	5.5	10.5	36.5	5.5	10.5	36.5	5.5	9.2	36.5	5.1	8.4	34	5.1	25	76	3600	2610
K21R 132 M4	K20R 132 S4	7.5	15	49.4	7.5	15	49.4	6.6	13	43.5	6.3	12.6	41.5	7	34	100	3600	2610
K21R 160 M4	K20R 132 M4	11	21	72	11	21	72.7	9.4	18	62	8.3	15.9	55	9.8	52	160	3600	2610
K21R 160 L4	K20R 160 S4	15	28	98	15	28	98.5	14.2	26.5	93	12.7	23.8	83.5	12	63	200	3600	2610
K21R 180 M4	K20R 160 M4	18	33.5	118	18	33.5	118	16	29.8	105	14.5	27	95	14	76	240	3000	2610
K21R 180 L4	K20R 180 S4	22	42	143	22	42	144	20	38.2	130	17	32.5	113	20	84	260	3000	2610
K21R 200 L4	K20R 180 M4	29	53.65	190	29	54	190	26	48.1	170	23	42.6	150	20	100	320	3000	2610
K21R 225 S4	K20R 200 M4	37	67	240	37	67	240	36	65.2	231	32	58	209	23	129	420	3000	2610
K21R 225 M4	K20R 200 L4	45	81	292	45	81	293	43	77.4	278	38	68.4	248	27	156	510	3000	2610
K21R 250 M4	K20R 225 M4	55	98.5	356	55	98.5	357	52	93.1	340	47	84.5	305	28	174	570	3000	2610
K21R 280 S4	K20R 250 S4	75	134	484	75	134	486	74	132	476	67	120	432	30	226	740	3000	2610
K21R 280 M4	K20R 250 M4	90	160	581	90	160	583	88	157	570	80	143	520	43	270	890	3000	2610
K21R 315 S4	K20R 280 S4	110	194	707	110	194	710	110	194	710	110	194	710	53	326	1080	3000	2610
K21R 315 M4	K20R 280 M4	132	233	849	132	233	852	132	233	852	132	233	852	59	393	1300	3000	2610
K21R 315 MX4	K20R 315 S4	160	279	1032	160	279	1029	160	279	1029	145	253	930	67	429	1440	3000	2610
K21R 315 MY4	K20R 315 M4	200	342	1286	200	342	1286	200	342	1286	192	328	1235	79	632	2160	3000	2610
K21R 315 L4	K20R 315 L4	250	417	1608	250	417	1608	250	417	1608	239	399	1540	100	737	2580	3000	2610
K21R 315 LX4	K20R 315 LX4	285	484	1833	277	470	1780	277	470	1780	264	448	1700	130	1029	3530	3000	2610
K22R 355 MY4		315	560	2016	315	560	2018	315	560	2018	293	521	1879		1250	4090	3000	2610
K22R 355 M4		355	630	2275	355	630	2275	355	630	2275	328	582	2100		1502	4930	3000	2610
K22R 355 MX4		390	692	2500	390	692	2500	390	692	2500	368	653	2358		1638	5360	3000	2610
K22R 355 LY4		430	782	2756	430	782	2755	413	782	2650	390	709	2500		1888	6050	3000	2610
K22R 355 L4		410	775	2628	410	775	2628	394	775	2528	390	737	2500		2180	6720	3000	2610

Three-phase motors with squirrel-cage rotor
Standard insulation for converter-fed operation without filter up to 420 V



with surface cooling, duty type S8, S9
 for rated voltage, thermal class 155 (F), degree of protection IP 55, 50 Hz

Motor selection data												Design point 400 V, 50 Hz	
Type IEC/DIN	Type Progressive	P _B	M _B	n _B	η _B	cosφ _B	I _B	I _A /I _B	M _A /M _B	M _S /M _B	M _R /M _B	J	m
		(IEC/EN 60034-2)			400 V								
		kW	Nm	rpm	%	-	A	-	-	-	-	kgm ²	kg
Synchronous speed 1000 rpm – 6-pole version													
K21R 63 K6	K20R 56 K6	0.09	0.96	895	50.5	0.56	0.46	2.5	2	2	2.4	0.00024	4.9
K21R 63 G6	K20R 56 G6	0.12	1.3	880	52	0.56	0.59	2.5	2	2	2.3	0.00027	5.7
K21R 71 K6	K20R 63 K6	0.18	1.86	925	58	0.51	0.88	2.8	1.6	1.6	2.1	0.00045	7.4
K21R 71 G6	K20R 63 G6	0.25	2.61	915	60	0.55	1.1	2.9	2	2	2.21	0.0006	8.3
K21R 80 K6	K20R 71 K6	0.37	3.86	915	66	0.66	1.22	3.4	2	2	2	0.0013	11
K21R 80 G6	K20R 71 G6	0.55	5.7	915	68	0.67	1.73	3.7	2.2	2.2	2.4	0.00175	12.5
K21R 90 S6	K20R 80 K6	0.75	7.7	935	70	0.64	2.43	4.5	2.4	2.4	2.6	0.00325	16
K21R 90 L6	K20R 80 G6	1.1	11.2	935	73	0.69	3.15	4.6	2.2	2.2	2.6	0.00425	19
K21R 100 L6	K20R 90 L6	1.5	15.2	945	76.4	0.73	3.9	4.6	2.1	2	2.4	0.00625	24
K21R 112 M6	K20R 100 L6	2.2	22.1	950	79.8	0.74	5.35	5.3	2.2	2.1	2.7	0.01225	33.5
K21R 132 S6T	K20R 100 LX6	3	30.6	935	81.9	0.75	7.05	5.2	2.5	2.5	2.9	0.0139	39
K21R 132 S6	K20R 112 M6	3	30	955	78.5	0.82	6.7	5.7	1.8	1.6	2.7	0.018	46
K21R 132 M6	K20R 112 MX6	4	40	955	80	0.8	9	6	2.2	2	3.1	0.023	53
K21R 132 MX6	K20R 132 S6	5.5	55	955	83	0.83	11.5	5	1.8	1.5	2.3	0.043	70
K21R 160 M6	K20R 132 M6	7.5	75	960	85	0.82	15.5	5.5	2	1.6	2.5	0.053	86
K21R 160 L6	K20R 160 S6	11	109	965	85.2	0.86	21.5	5	2	1.7	2.3	0.113	114
K21R 180 L6	K20R 160 M6	15	148	965	86	0.83	30.5	6	2.4	2.1	2.7	0.145	136
K21R 200 L6	K20R 180 S6	18.5	182	970	88.1	0.87	35	5.5	2	1.7	2.4	0.228	175
K21R 200 LX6	K20R 180 M6	22	217	970	88.8	0.87	41	6.2	2.2	1.8	2.6	0.268	200
K21R 225 M6	K20R 200 M6	30	294	973	90.4	0.89	54	6.5	2.2	1.7	2.5	0.443	265
K21R 250 M6	K20R 225 M6	37	362	975	91	0.89	66	6.5	2.2	1.7	2.3	0.825	360
K21R 280 S6	K20R 250 S6	45	439	980	92	0.87	81	6	2	1.5	2	1.28	465
K21R 280 M6	K20R 250 M6	55	536	980	92.5	0.88	97.5	6.5	2.3	1.7	2.4	1.48	520
K21R 315 S6	K20R 280 S6	75	727	985	93.7	0.87	133	7	2	1.6	2.4	2.63	690
K21R 315 M6	K20R 280 M6	90	868	990	94.4	0.88	156	7	2	1.7	2.4	3.33	800
K21R 315 MX6	K20R 315 S6	110	1061	990	94	0.88	192	7.5	2.2	1.7	2.6	3.6	880
K21R 315 MY6	K20R 315 M6	132	1273	990	95	0.88	228	7.5	2	1.7	2.4	6	1050
K21R 315 L6	K20R 315 L6	160	1551	985	95.3	0.89	272	7.5	2.3	1.9	2.4	6.67	1250
K21R 315 LX6	K20R 315 LX6	200	1929	990	95	0.87	349	8.3	2.2	2	2.7	8.6	1460
K22R 355 MY6		200	1920	995	96.1	0.83	362	7	1.5	1.3	2.4	8.1	1550
K22R 355 M6		250	2402	994	96	0.81	464	7	1.8	1.3	2.3	8.2	1650
K22R 355 MX6		315	3023	995	96.5	0.83	568	6.8	1.6	1.3	2.5	12.1	2200
K22R 355 LY6		355	3407	995	96	0.78	684	7.4	1.9	1.4	2.6	14	2400

Motor selection data

Type IEC/DIN	Type Progressive	Converter input, 50 Hz			Setting range 1 : 2.5			Setting range 1 : 5			Setting range 1 : 10			I ₀ kW	I _{max} A	M _{max} Nm	n _{max} rpm	n _{maxFU} rpm
		P _{50 Hz}	i _B	M _B	P _{1:2.5}	i _B	M _B	P _{1:5}	i _B	M _B	P _{1:10}	i _B	M _B					
		kW	A	Nm	kW	A	Nm	kW	A	Nm	kW	A	Nm					
Synchronous speed 1000 rpm – 6-pole version																		
K21R 63 K6	K20R 56 K6	0.09	0.46	0.98	0.06		0.7	0.06		0.57	0.04	0.45			1.7	12000	1740	
K21R 63 G6	K20R 56 G6	0.12	0.59	1.31	0.09		0.94	0.07		0.77	0.06	0.61			2.3	12000	1740	
K21R 71 K6	K20R 63 K6	0.16	0.88	1.66	0.12		1.28	0.08		0.85	0.06	0.6			3	11000	1740	
K21R 71 G6	K20R 63 G6	0.22	1.1	2.3	0.17		1.78	0.11		1.19	0.08	0.84			4.4	11000	1740	
K21R 80 K6	K20R 71 K6	0.37	1.22	3.9	0.28		2.9	0.18		1.94	0.14	1.5			5.9	10000	1740	
K21R 80 G6	K20R 71 G6	0.55	1.73	5.8	0.42		4.4	0.27		2.9	0.22	2.3			10	10000	1740	
K21R 90 S6	K20R 80 K6	0.75	2.43	7.6	0.52		5.3	0.4		4.1	0.31	3.2			15	9000	1740	
K21R 90 L6	K20R 80 G6	1.1	3.15	11.3	0.72		7.8	0.59		6.1	0.46	4.7			22	9000	1740	
K21R 100 L6	K20R 90 L6	1.5	3.9	15.3	1.2		12.2	0.96		10	0.76	7.7			27	8000	1740	
K21R 112 M6	K20R 100 L6	2.2	5.35	22.3	1.76		17.9	1.44		14.8	1.12	11.5			45	6000	1740	
K21R 132 S6T	K20R 100 LX6	3	7.05	30.8	2.4		24.6	2		20.2	1.6	16.3			68	6000	1740	
K21R 132 S6	K20R 112 M6	3	6.7	30.8	3	6.7	30.8	3	6.3	30.8	3	30.8	4.3	13.8	56	2400	1740	
K21R 132 M6	K20R 112 MX6	4	9	40.6	4	9	40.6	4	8.3	40.6	4	40.6	5.9	22	86	2400	1740	
K21R 132 MX6	K20R 132 S6	5.5	11.5	55	5.5	11.5	55.9	5.1	10.7	51.4	4.3	9	44	5.9	88	2400	1740	
K21R 160 M6	K20R 132 M6	7.5	15.5	75	7.5	15.5	75.8	6.9	14.3	70	5.9	12.2	60	8.5	130	2400	1740	
K21R 160 L6	K20R 160 S6	11	21.5	109	11	21.5	111	10	19.5	101	9.4	18.4	94	9.5	37	170	2400	1740
K21R 180 L6	K20R 160 M6	15	30.5	148	15	30.5	148	13.6	27.7	135	12.6	25.6	125	17	64	280	2000	1740
K21R 200 L6	K20R 180 S6	18.5	35	182	18	34	183	17	32.5	169	16	30.5	157	13.5	64	300	2000	1740
K21R 200 LX6	K20R 180 M6	22	41	217	22	41	218	20	37.5	200	19	35.5	188	16	82	390	2000	1740
K21R 225 M6	K20R 200 M6	30	54	294	30	54	295	30	54	295	29	52.5	286	18	103	510	2000	1740
K21R 250 M6	K20R 225 M6	37	66	362	37	66	362	37	66	362	36	64.5	350	24	117	580	2000	1740
K21R 280 S6	K20R 250 S6	45	81	439	45	81	441	45	81	441	45	81	441	24.5	124	610	2000	1740
K21R 280 M6	K20R 250 M6	55	97.5	536	55	97.5	539	55	97.5	539	55	97.5	539	32	181	900	2000	1740
K21R 315 S6	K20R 280 S6	75	133	727	75	133	731	75	133	731	75	133	731	42	246	1220	2000	1740
K21R 315 M6	K20R 280 M6	90	156	868	90	156	873	90	156	873	90	156	873	47.5	287	1450	2000	1740
K21R 315 MX6	K20R 315 S6	110	192	1061	110	192	1066	107	187	1040	100	175	970	62	385	1930	2000	1740
K21R 315 MY6	K20R 315 M6	132	228	1273	132	228	1280	132	228	1280	132	228	1280	66.5	420	2130	2000	1740
K21R 315 L6	K20R 315 L6	160	272	1551	160	272	1551	160	272	1551	160	272	1551	80	502	2600	2000	1740
K21R 315 LX6	K20R 315 LX6	185	323	1794	185	323	1794	185	323	1794	175	305	1700	115	725	3640	2000	1740
K22R 355 MY6		200	362	1920	200	362	1929	200	362	1929	185	335	1780		668	3220	2000	1740
K22R 355 M6		250	464	2402	250	464	2412	250	464	2412	238	442	2300		821	3860	2000	1740
K22R 355 MX6		300	541	2894	300	541	2894	300	541	2894	298	537	2870		1094	5290	2000	1740
K22R 355 LY6		315	607	3023	315	607	3023	315	607	3023	315	607	3023		1370	6200	2000	1740

Three-phase motors with squirrel-cage rotor
Standard insulation for converter-fed operation without filter up to 420 V



with surface cooling, duty type S8, S9
 for rated voltage, thermal class 155 (F), degree of protection IP 55, 50 Hz

Motor selection data												Design point 400 V, 50 Hz	
Type IEC/DIN	Type Progressive	P _B	M _B	n _B	η _B	cosφ _B	I _B	I _M /I _B	M _A /M _B	M _S /M _B	M _R /M _B	J	m
		(IEC/EN 60034-2)				400 V						kgm ²	kg
		kW	Nm	rpm	%	-	A	-	-	-	-		
Synchronous speed 750 rpm – 8-pole version													
K21R 71 K8	K20R 63 K8	0.09	1.27	675	45.5	0.51	0.56	2.1	1.9	1.9	2.1	0.0005	6.6
K21R 71 G8	K20R 63 G8	0.12	1.71	670	46.5	0.51	0.73	2.3	1.8	1.8	2.1	0.0006	8.1
K21R 80 K8	K20R 71 K8	0.18	2.49	690	56.5	0.59	0.78	2.8	2	2	2.2	0.0013	10.5
K21R 80 G8	K20R 71 G8	0.25	3.44	695	58	0.56	1.12	3	2.3	2.3	2.5	0.00175	12
K21R 90 S8	K20R 80 K8	0.37	5	700	61.5	0.54	1.6	3	1.9	1.9	2.1	0.003	15
K21R 90 L8	K20R 80 G8	0.55	7.6	695	64.5	0.6	2.04	3.2	1.9	1.9	2.2	0.00375	18
K21R 100 L8	K20R 90 L8	0.75	10.2	705	63	0.6	2.9	3.3	1.8	1.8	2.2	0.00625	23
K21R 100 LX8	K20R 100 S8	1.1	14.9	705	73	0.67	3.25	4	2	2	2.4	0.009	28
K21R 112 M8	K20R 100 L8	1.5	20.3	705	75.5	0.7	4.1	4.4	2.2	2.1	2.5	0.01225	33.5
K21R 132 S8T	K20R 100 LX8	2.2	30.7	685	74.1	0.68	6.3	3.8	2	1.9	2.3	0.0139	39
K21R 132 S8	K20R 112 M8	2.2	29.8	705	75.5	0.76	5.5	4.5	1.7	1.6	2.3	0.018	46
K21R 132 M8	K20R 112 MX8	3	40.6	705	78	0.75	7.4	4.5	1.7	1.6	2.3	0.023	53
K21R 160 M8	K20R 132 S8	4	53.8	710	79.3	0.78	9.3	4	1.6	1.3	1.9	0.043	70
K21R 160 MX8	K20R 132 M8	5.5	74	710	81.4	0.78	12.5	4.5	1.7	1.6	2.1	0.053	86
K21R 160 L8	K20R 160 S8	7.5	99	725	83	0.78	16.5	4.5	1.8	1.6	2.1	0.113	114
K21R 180 L8	K20R 160 M8	11	146	720	85	0.78	24	4.5	2	1.7	2.1	0.145	136
K21R 200 L8	K20R 180 S8	15	198	725	86.5	0.79	31.5	5	2	1.7	2.3	0.228	175
	K20R 180 M8	18.5	244	725	87.5	0.8	38	5	1.9	1.7	2.2	0.268	200
K21R 225 S8		18.5	244	725	89.2	0.83	36	5.5	2	1.6	2.2	0.44	265
K21R 225 M8	K20R 200 M8	22	290	725	89.2	0.84	42.5	5	1.8	1.5	2.2	0.44	265
K21R 250 M8	K20R 225 M8	30	392	730	90.2	0.79	61	5.5	2.2	1.8	2.2	0.825	360
K21R 280 S8	K20R 250 S8	37	481	735	91	0.8	73.5	5.5	2	1.5	2	1.35	465
K21R 280 M8	K20R 250 M8	45	585	735	91.5	0.77	92	6	2.3	1.8	2.4	1.55	520
K21R 315 S8	K20R 280 S8	55	710	740	93.1	0.8	107	6.5	1.8	1.6	2.3	2.63	690
K21R 315 M8	K20R 280 M8	75	968	740	93.3	0.81	143	6	2	1.6	2.3	3.33	800
K21R 315 MX8	K20R 315 S8	90	1161	740	93.5	0.81	172	6	1.9	1.6	2.2	3.6	880
K21R 315 MY8	K20R 315 M8	110	1420	740	94.6	0.81	207	6.5	2.1	1.8	2.4	6	1100
K21R 315 L8	K20R 315 L8	132	1704	740	95	0.83	242	6.3	2	1.7	2.1	6.76	1250
K21R 315 LX8	K20R 315 LX8	160	2065	740	95.2	0.79	307	7.2	2.2	1.9	2.5	8.71	1430
K22R 355 MY8		160	2054	744	95.2	0.8	303	6.8	1.3	1	2.5	9.3	1500
K22R 355 M8		200	2571	743	95.6	0.77	392	6.5	1.6	1	2.7	9.5	1600
K22R 355 MX8		250	3209	744	95.8	0.78	483	6.6	1.3	1	2.8	13.4	2200
K22R 355 LY8		280	3594	744	95.3	0.78	544	8.2	1.2	1	2.8	15.8	2400

Motor selection data

Type IEC/DIN	Type Progressive	Converter input, 50 Hz			Setting range 1 : 2.5			Setting range 1 : 5			Setting range 1 : 10			I ₀ kW	I _{max} A	M _{max} Nm	n _{max} rpm	n _{maxFU} rpm
		P _{50 Hz}	i _B	M _B	P _{1:2.5}	i _B	M _B	P _{1:5}	i _B	M _B	P _{1:10}	i _B	M _B					
		kW	A	Nm	kW	A	Nm	kW	A	Nm	kW	A	Nm					
Synchronous speed 750 rpm – 8-pole version																		
K21R 71 K8	K20R 63 K8	0.09	0.56	1.31	0.06		0.89	0.03		0.52	0.02		0.32			2	11000	1305
K21R 71 G8	K20R 63 G8	0.12	0.73	1.76	0.08		1.21	0.05		0.7	0.03		0.43			2.7	11000	1305
K21R 80 K8	K20R 71 K8	0.18	0.78	2.47	0.14		1.92	0.12		1.68	0.09		1.16			4.2	10000	1305
K21R 80 G8	K20R 71 G8	0.25	1.12	3.46	0.2		2.7	0.18		2.5	0.12		1.66			6.6	10000	1305
K21R 90 S8	K20R 80 K8	0.37	1.6	5	0.29		3.9	0.19		2.6	0.15		2.1			8.1	9000	1305
K21R 90 L8	K20R 80 G8	0.55	2.04	7.6	0.43		6	0.3		4.1	0.23		3.2			12	9000	1305
K21R 100 L8	K20R 90 L8	0.75	2.9	10.3	0.56		7.7	0.39		5.4	0.29		4			17	8000	1305
K21R 100 LX8	K20R 100 S8	1.1	3.25	15.3	0.88		12.2	0.69		9.6	0.48		6.7			27	6000	1305
K21R 112 M8	K20R 100 L8	1.5	4.1	20.8	1.2		16.6	0.96		13.2	0.66		9.2			39	6000	1305
K21R 132 S8T	K20R 100 LX8	2.1	6.3	29.5	1.28		18.2	1.04		15	0.84		11.8			54	6000	1305
K21R 132 S8	K20R 112 M8	2.2	5.5	30	2.2	5.5	30	2.2	4.75	30	2.09	4.1	28.5	4	9.6	47	1800	1305
K21R 132 M8	K20R 112 MX8	3	7.4	40.9	3	7.4	40.9	3	6.4	40.9	2.85	5.4	38.8	5.1	13.1	65	1800	1305
K21R 160 M8	K20R 132 S8	4	9.3	53.8	4	9.3	54.6	3.6	8.4	48.6	3.2	7.4	43.7	5	13.5	71	1800	1305
K21R 160 MX8	K20R 132 M8	5.5	12.5	74	5.5	12.5	75	4.9	11.1	67	4.4	10	60	8	18.6	100	1800	1305
K21R 160 L8	K20R 160 S8	7.5	16.5	99	7.5	16.5	102	6.6	14.5	89.8	6.2	13.6	83.6	10	26	140	1800	1305
K21R 180 L8	K20R 160 M8	11	24	146	11	24	147	9.7	21.2	130	9	19.6	120	14	38	210	1500	1305
K21R 200 L8	K20R 180 S8	15	31.5	198	14	29.4	184	12.6	26.5	168	11.4	23.9	152	18	55	310	1500	1305
	K20R 180 M8	18.5	38	244	17	35	225	15.3	31.4	205	13.9	28.6	185	18	64	370	1500	1305
K21R 225 S8		18.5	36	244	17	33.1	225	15.6	30.4	205	14	27.2	185	16	61	370	1500	1305
K21R 225 M8	K20R 200 M8	22	42.5	290	20	38.6	264	18.3	35.4	241	16.5	31.9	217	20	71	440	1500	1305
K21R 250 M8	K20R 225 M8	30	61	392	30	61	392	29	59	380	26	52.9	345	31	103	600	1500	1305
K21R 280 S8	K20R 250 S8	37	73.5	481	37	73.5	481	37	73.5	481	37	73.5	481	35	113	670	1500	1305
K21R 280 M8	K20R 250 M8	45	92	585	45	92	585	45	92	585	45	92	585	44	170	980	1500	1305
K21R 315 S8	K20R 280 S8	55	107	710	55	107	710	55	107	710	55	107	710	46	190	1140	1500	1305
K21R 315 M8	K20R 280 M8	75	143	968	75	143	968	75	143	968	75	143	968	62	252	1550	1500	1305
K21R 315 MX8	K20R 315 S8	90	172	1161	90	172	1169	90	172	1169	85	162	1100	81	290	1780	1500	1305
K21R 315 MY8	K20R 315 M8	110	207	1420	110	207	1429	110	207	1429	106	199	1373	86	382	2380	1500	1305
K21R 315 L8	K20R 315 L8	132	242	1704	132	242	1715	132	242	1715	127	233	1650	90	391	2500	1500	1305
K21R 315 LX8	K20R 315 LX8	145	278	1871	145	278	1871	145	278	1871	145	278	1871	140	591	3610	1500	1305
K22R 355 MY8		160	303	2054	160	303	2051	160	303	2051	153	290	1960		583	3590	1500	1305
K22R 355 M8		200	392	2571	200	392	2564	200	392	2564	184	361	2360		814	4850	1500	1305
K22R 355 MX8		225	435	2884	225	435	2884	225	435	2884	225	435	2884		1040	6280	1500	1305
K22R 355 LY8		230	447	2948	230	447	2948	230	447	2948	230	447	2948		1173	7040	1500	1305

Three-phase motors with squirrel-cage rotor, Premium Efficiency IE3 for converter-fed operation without filter up to 500 V

with surface cooling, duty type S8, S9
for rated voltage, thermal class 155 (F), degree of protection IP 55, 50 Hz

Motor selection data														Design point 400 V, 50 Hz		
Type	P _B	M _B	P _B	n _B	η _B			cosφ _B	I _B	I _A /I _B	M _A /M _B	M ₂ /M _B	M _K /M _B	J	m	
	Converter kW	Nm	Mains kW	rpm	(IEC/EN 60034-2) 100 % 75 % 50 %			-	400 V A	-	-	-	-	kgm ²	kg	
Synchronous speed 3000 rpm – 2-pole version																
IE3-WU1R 56 G2	0.12	0.4	0.12	2830	IE3-	60.8	59.4	55.9	0.77	0.32	4.5	2.1	2.1	2.3	0.00013	4.5
IE3-WU2R 80 K2	0.18	0.6	0.18	2790	IE3-	65.9	63.1	58.8	0.76	0.51	4.1	1.9	1.9	2.2	0.00013	4.9
IE3-WU1R 63 G2	0.25	0.9	0.25	2825	IE3-	69.7	70.1	67.1	0.83	0.58	4.9	2.4	2.2	2.7	0.00025	6.3
IE3-WU2R 71 K2	0.37	1.2	0.37	2840	IE3-	73.8	74.1	71.7	0.82	0.83	5.8	2.8	2.7	3.2	0.00032	7.6
IE3-WU1R 71 G2	0.55	1.8	0.55	2870	IE3-	77.8	77.5	74.4	0.79	1.23	6.3	2.9	2.9	3.5	0.00057	10
IE3-WU2R 80 K2	0.75	2.50	0.75	2870	IE3-	80.7	80.7	78.2	0.81	1.65	6.4	2.6	2.6	3.5	0.00072	11.5
IE3-WU1R 80 GY2	1.1	3.66	1.1	2870	IE3-	82.7	83.8	82.6	0.86	2.22	7.0	2.8	2.7	3.4	0.00132	15
IE3-WU2R 90 S2	1.5	4.94	1.5	2900	IE3-	84.2	85.4	83.2	0.81	3.12	7.9	3.5	3.5	4.4	0.0017	19
IE3-WU1R 90 LY2	2.2	7.30	2.2	2880	IE3-	85.9	85.7	83.9	0.88	4.25	8.0	2.5	2.3	2.9	0.00275	23.5
IE3-WU1R 100 LY2	3	9.81	3	2920	IE3-	87.1	88	86.3	0.82	6.0	7.7	2.3	2.2	3.5	0.0045	31
IE3-WU1R 112 MY2	4	13.10	4	2920	IE3-	88.1	87.5	86.9	0.84	7.9	8.3	2.3	2.1	3.3	0.0055	38
IE3-WU1R 132 S2T	5.5	18.0	5.5	2925	IE3-	89.2	89.4	87.7	0.80	11.1	8.3	2.6	2.5	3.8	0.0068	48
IE3-WU0R 112 M2	4	13.0	4	2930	IE3-	89.2	89.2	87.9	0.87	7.4	6.9	1.5	1.2	2.9	0.011	60
IE3-WU1R 132 S2	5.5	18.0	5.5	2930	IE3-	89.2	88.6	87.0	0.84	10.5	7.7	1.9	1.3	3.5	0.011	65
IE3-WU1R 132 SX2	7.5	24.0	7.5	2925	IE3-	90.1	89.4	87.9	0.87	14.0	8.0	2.5	2.1	3.3	0.0168	75
IE3-WU1R 160 M2	11	36.0	11	2950	IE3-	91.4	91.7	90.5	0.90	19.5	8.0	2.2	1.8	3.2	0.0575	125
IE3-WU1R 160 MX2	15	49.0	15	2950	IE3-	91.9	92.0	91.3	0.91	26.0	7.9	2.2	1.7	3.1	0.0675	145
IE3-WU1R 160 L2	18.5	60.0	18.5	2960	IE3-	92.4	92.5	91.4	0.90	32.0	9.2	2.6	2.1	3.6	0.078	160
IE3-WU1R 180 M2C	22	71	22	2975	IE3-	92.7	92.6	91.5	0.91	37.5	8.9	1.9	1.4	3.3	0.1717	214
IE3-WU1R 200 L2	30	97	30	2965	IE3-	93.3	92.2	90.6	0.88	52.5	8.6	2.1	1.6	3.3	0.36	305
IE3-WU1R 200 LX2C	37	119	37	2980	IE3-	93.7	92.9	91.7	0.89	64.0	8.7	1.7	1.3	3.2	0.4757	310
IE3-WU1R 225 M2	45	145	45	2960	IE3-	94.0	93.7	93.0	0.89	77.5	8.8	2.3	1.9	3.2	0.375	375
IE3-WU1R 250 M2	55	177	55	2970	IE3-	94.6	94.4	93.6	0.91	92	8.9	2.2	1.9	3.2	0.65	510
IE3-WU1R 280 S2	75	241	75	2967	IE3-	94.7	94.5	93.9	0.89	128	8.1	1.9	1.9	2.8	0.65	500
IE3-WU1R 280 M2	85	273	90	2970	IE3-	95	94.5	94	0.90	152	8.4	2.2	1.8	3.1	0.675	545
IE3-WU1R 315 S2	110	354	110	2970	IE3-	95.2	94.5	93.5	0.89	187	10.0	1.9	1.7	3.0	1.21	750
IE3-WU1R 315 M2	132	423	132	2980	IE3-	95.4	95.0	94.5	0.89	224	10.0	2.0	1.8	3.0	1.44	815
IE3-WU2R 315 MX2	160	513	160	2980	IE3-	95.7	95.7	95.0	0.9	268	8.5	2.3	1.7	2.6	2.37	1095
IE3-WU1R 315 MY2	192	615	200	2980	IE3-	95.8	95.9	95.5	0.91	331	8.3	2.6	1.6	2.4	2.82	1200
IE3-WU1R 315 L2	220	704	250	2985	IE3-	96.0	96.0	95.9	0.92	409	8.4	2.5	1.4	2.3	3.66	1460
IE3-WU1R 315 LX2	270	864	315	2985	IE3-	95.8	95.8	95.8	0.92	516	8.5	2.8	1.6	2.5	4.43	1700
IE3-WU1R 355 M2	330	1056	355	2985	IE3-	96.0	96.0	96.0	0.92	580	7.7	1.9	1.5	3.8	4.20	2000
IE3-WU2R 355 MX2	355	1135	400	2988	IE3-	96.0	96.0	96.0	0.92	654	8.5	1.8	1.1	2.5	5.50	2275
IE3-WU2R 355 L2	370	1182	500	2990	IE3-	96.2	96.2	96.2	0.90	834	11.0	2.2	1.4	3.2	7.10	2445
IE3-WU2R 400 M2	450	1435	560	2995	IE3-	96.0	96.0	95.5	0.83	1014	9.0	2.8		3.0	8.44	3000
IE3-WU2R 400 MX2	500	1596	630	2992	IE3-	96.0	96.0	95.5	0.91	1041	9.5	2.5		2.7	9.41	3200
IE3-WU2R 400 L2	580	1856	710	2985	IE3-	96.0	96.0	95.5	0.90	1186	7.7	2.2	1.1	2.8	10.41	3450

Three-phase motors with squirrel-cage rotor, Premium Efficiency IE3 for converter-fed operation without filter up to 500 V

with surface cooling, duty type S8, S9
for rated voltage, thermal class 155 (F), degree of protection IP 55, 50 Hz

Motor selection data													Design point 400 V, 50 Hz			
Type	P _B M _B Converter		P _B Mains	n _B rpm	IE3-	η _B (IEC/EN 60034-2)			cosφ _B	I _B 400 V A	I _A /I _B	M _A /M _B	M ₂ /M _B	M _K /M _B	J kgm ²	m kg
	kW	Nm				kW	100 %	75 %								
Synchronous speed 1500 rpm – 4-pole version																
IE3-WU2R 63 K4	0.12	0.8	0.12	1365	IE3-	64.8	64.5	59.7	0.72	0.37	3.2	1.9	1.8	2.2	0.00024	5.2
IE3-WU1R 63 G4	0.18	1.2	0.18	1415	IE3-	69.9	67.2	61.2	0.67	0.55	4.4	1.8	1.8	2.7	0.0005	7.1
IE3-WU2R 71 K4	0.25	1.7	0.25	1395	IE3-	73.5	71.2	66.7	0.70	0.72	3.9	2.1	2.1	2.5	0.0005	7.8
IE3-WU1R 71 GY4	0.37	2.5	0.37	1425	IE3-	77.3	76.8	73	0.69	1	4.9	2.4	2.4	3	0.00087	9.9
IE3-WU1R 80 K4	0.55	3.7	0.55	1430	IE3-	80.8	81	80.1	0.80	1.25	6	2.4	2.3	2.7	0.00207	14.5
IE3-WU1R 80 G4	0.75	4.96	0.75	1445	IE3-	82.5	82.3	79.6	0.77	1.70	7.0	3.1	3.1	3.7	0.0026	17.0
IE3-WU1R 90 SY4	1.1	7.30	1.1	1440	IE3-	84.1	82.6	79.7	0.76	2.5	6.7	2.8	2.7	3.7	0.004	22.5
IE3-WU1R 90 L4	1.5	9.91	1.5	1445	IE3-	85.3	83.2	80.7	0.77	3.35	7.2	3.2	3.0	3.5	0.0045	28
IE3-WU1R 100 LY4	2.2	14.4	2.2	1455	IE3-	86.7	85.2	81.7	0.77	4.80	9.3	3.2	3.0	3.6	0.009	36
IE3-WU1R 100 LX4	3	19.7	3	1455	IE3-	87.7	86.3	84.5	0.77	6.50	9.0	3.3	3.1	3.9	0.011	45
IE3-WU1R 112 M4	4	26	4	1470	IE3-	89.9	89.8	88.4	0.83	7.7	9.5	2.8	2.4	4.5	0.02	65
IE3-WU1R 132 S4	5.5	35	5.5	1480	IE3-	91.0	90.2	87.8	0.73	12.0	9.9	3.4	2.8	5.4	0.035	90
IE3-WU1R 132 M4	7.5	49	7.5	1475	IE3-	91.3	91.3	90.1	0.83	14.5	8.6	2.4	2.0	3.9	0.043	100
IE3-WU1R 160 M4	11	71	11	1475	IE3-	91.5	91.5	90.5	0.83	21.0	7.5	2.5	2.0	3.2	0.078	125
IE3-WU1R 160 L4C	15	96	15	1490	IE3-	92.8	92.5	91.0	0.83	28.0	10.5	2.8	2.4	3.9	0.1567	175
IE3-WU1R 180 M4	18.5	120	18.5	1475	IE3-	92.7	92.9	92.0	0.84	34.5	6.9	1.9	1.7	3.0	0.168	210
IE3-WU1R 180 L4	22	142	22	1480	IE3-	93.0	93.0	92.1	0.84	40.5	7.6	2.2	2.0	3.2	0.203	240
IE3-WU1R 200 L4C	30	193	30	1485	IE3-	93.6	93.2	92.4	0.85	54.5	7.0	1.6	1.4	2.6	0.411	327
IE3-WU1R 225 S4C	37	237	37	1490	IE3-	93.9	93.8	93.2	0.85	67.0	7.4	1.9	1.4	2.7	0.4675	367
IE3-WU1R 225 M4	45	290	45	1482	IE3-	94.2	94.3	94.0	0.82	84	8.1	2.6	2.1	2.6	0.619	450
IE3-WU1R 250 M4	55	354	55	1485	IE3-	94.7	94.8	94.4	0.83	101	8.1	2.1	1.8	2.5	0.95	550
IE3-WU1R 280 S4	75	482	75	1485	IE3-	95.0	94.6	94.2	0.83	137	8.2	2.1	1.8	2.5	1.1	617
IE3-WU1R 280 M4	90	578	90	1487	IE3-	95.2	94.7	94.0	0.83	164	9.5	1.9	1.7	2.6	1.96	785
IE3-WU1R 315 S4	110	706	110	1487	IE3-	95.4	95.0	94.3	0.82	203	9.5	1.9	1.7	2.7	1.96	760
IE3-WU1R 315 M4	132	849	132	1485	IE3-	95.6	95.4	95.0	0.83	240	9.0	2.2	1.9	2.7	2.27	850
IE3-WU1R 315 MX4	160	1026	160	1490	IE3-	95.8	95.8	95.5	0.84	287	9.5	2.1	2.0	3.2	4.01	1120
IE3-WU1R 315 MY4	200	1282	200	1490	IE3-	96.0	95.8	95.5	0.87	346	9.5	2.1	1.7	2.7	4.82	1250
IE3-WU1R 315 L4	250	1602	250	1490	IE3-	96.2	96.2	96.0	0.87	431	9.4	2.2	1.8	2.7	5.93	1450
IE3-WU1R 315 LX4	285	1827	315	1490	IE3-	96.0	96.0	96.0	0.87	544	9.5	2.3	1.7	2.9	6.82	1630
IE3-WU1R 355 M 4	355	2271	355	1493	IE3-	96.2	96.2	95.5	0.87	612	8.1	1.3	1.0	2.7	7.90	2150
IE3-WU2R 355 MX4	390	2500	400	1490		96.2	96.2	96.2	0.84	714	8.2	1.7	1.4	2.4	9.50	2410
IE3-WU2R 355 L4	480	3077	500	1490		96.4	96.4	96.0	0.84	891	7.4	2.5	1.2	2.3	10.00	2500
IE3-WU2R 400 M4	500	3198	560	1493		96.3	96.3	96.0	0.87	965	10.5	2.0		2.5	12.60	2900
IE3-WU2R 400 MX4	580	3707	630	1494		96.5	96.5	96.0	0.86	1096	10.0	3.1		3.3	14.33	3100
IE3-WU2R 400 L4	650	4158	710	1493		96.5	96.5	96.5	0.86	1235	11.4	4.1		3.8	16.29	3400

Three-phase motors with squirrel-cage rotor, Premium Efficiency IE3 for converter-fed operation without filter up to 500 V

with surface cooling, duty type S8, S9
for rated voltage, thermal class 155 (F), degree of protection IP 55, 50 Hz

Motor selection data													Design point 400 V, 50 Hz			
Type	P _B M _B Converter		P _B Mains	n _B rpm	IE3-	η _B (IEC/EN 60034-2)			cosφ _B	I _B 400 V A	I _A /I _B	M _A /M _B	M ₂ /M _B	M _K /M _B	J kgm ²	m kg
	kW	Nm				100 %	75 %	50 %								
Synchronous speed 1000 rpm – 6-pole version																
IE3-WU1R 63 G6	0.12	1.23	0.12	930	IE3-	57.7	60.0	54	0.56	0.5	2.8	1.9	1.8	2.1	0.00045	6.7
IE3-WU2R 71 KY6	0.18	1.89	0.18	910	IE3-	63.9	62.0	56.5	0.55	0.75	2.9	1.7	1.7	2.1	0.0006	8.3
IE3-WU1R 71 GY6	0.25	2.54	0.25	940	IE3-	68.6	65.3	58.5	0.63	0.84	4	2.2	2.2	2.9	0.0013	10
IE3-WU1R 80 K6	0.37	3.72	0.37	950	IE3-	73.5	72.9	69.2	0.7	1.03	4	1.9	1.9	2.4	0.00325	15
IE3-WU1R 80 G6	0.55	5.53	0.55	950	IE3-	77.2	75.9	72.4	0.69	1.5	4.1	2.1	2.1	2.5	0.00425	18
IE3-WU1R 90 SY6	0.75	7.50	0.75	955	IE3-	78.9	78.3	75.1	0.71	1.95	4.9	2.4	2.3	2.6	0.00625	24
IE3-WU1R 90 L6	1.1	11.00	1.1	955	IE3-	81.0	81.0	78.5	0.72	2.75	5.4	2.5	2.4	2.8	0.0072	30
IE3-WU1R 100 LX6	1.5	15.00	1.5	955	IE3-	82.5	83.5	81.5	0.76	3.45	5.9	2.3	2.2	2.8	0.0139	36
IE3-WU1R 112 MV6	2.2	22.00	2.2	955	IE3-	84.3	83.6	80.9	0.74	5.15	5.7	2.4	2.3	2.9	0.0155	48
IE3-WU1R 112 M6	2.2	***	2.2	***	IE3-	84.3	***	***	***	***	***	***	***	***	***	***
IE3-WU1R 132 S6	3	30.0	3	965	IE3-	86.3	86.7	85.6	0.82	6.1	6.2	2.0	1.3	3.1	0.029	70
IE3-WU1R 132 M6	4	40.0	4	965	IE3-	86.8	87.0	86.0	0.80	8.3	4.8	1.7	1.4	2.4	0.043	75
IE3-WU1R 132 MX6	5.5	54.0	5.5	970	IE3-	88.6	88.6	87.2	0.80	11.0	6.0	2.1	1.7	3.0	0.053	105
IE3-WU1R 160 M6	7.5	73.0	7.5	980	IE3-	90.2	90.0	88.3	0.83	14.5	6.4	2.4	2.0	3.0	0.145	145
IE3-WU1R 160 L6C	11	107.0	11	985	IE3-	91.4	91.2	89.8	0.85	20.5	6.8	2.2	2	2.8	0.166	168
IE3-WU1R 180 L6C	15	145.0	15	985	IE3-	91.2	91.3	90.2	0.87	27.5	6.8	2	1.7	2.7	0.3396	214
IE3-WU1R 200 L6	18.5	180.0	18.5	980	IE3-	91.8	91.7	90.5	0.87	33.5	7.2	2.3	2	3	0.514	310
IE3-WU1R 200 LX6C	22	213.0	22	985	IE3-	92.2	91.5	90	0.87	39.5	7.6	2.1	1.7	2.9	0.6476	321
IE3-WU1R 225 M6	30	291	30	984	IE3-	92.9	92.2	91.0	0.84	55.5	7.2	2.7	2.2	2.9	0.92	400
IE3-WU1R 250 M6	37	359	37	985	IE3-	93.3	93.2	92.3	0.86	66.5	7.1	2.8	2.0	2.7	1.48	545
IE3-WU1R 280 S6	45	434	45	990	IE3-	93.7	93.0	91.5	0.86	80.5	8.5	2.1	1.8	2.8	2.63	695
IE3-WU1R 280 M6	55	531	55	990	IE3-	94.2	94.1	93.1	0.85	99	9.0	2.2	1.8	3.1	3.33	815
IE3-WU2R 315 S6	75	723	75	990	IE3-	94.6	94.0	93.5	0.86	133	8.2	1.8	1.4	2.3	5.55	1060
IE3-WU1R 315 M6	90	868	90	990	IE3-	94.9	94.3	93.5	0.83	165	8.5	2.2	1.7	2.7	6	1140
IE3-WU1R 315 MX6	110	1.061	110	990	IE3-	95.1	95.0	94.5	0.86	194	8.5	2.5	1.7	2.7	6.67	1210
IE3-WU1R 315 L6	132	1.267	132	995	IE3-	95.4	95.0	94.5	0.87	230	9.0	2.8	2.0	3.2	8.6	1550
IE3-WU1R 355 M6	160	1.536	160	995	IE3-	95.6	95.6	95.2	0.86	281	7.5	1.6	1.3	2.4	8.2	1850
IE3-WU1R 355 MX6	200	1919	200	995	IE3-	95.8	95.5	95.0	0.86	350	9.0	1.9	1.7	2.7	12.10	2200
IE3-WU2R 355 MX6	200	1919	200	995	IE3-	95.8	95.5	95.0	0.84	359	9.6	2.2	1.7	2.8	12.10	2350
IE3-WU2R 355 LY 6	250	2399	250	995	IE3-	95.8	95.5	95.0	0.82	459	8.0	1.8	1.5	2.5	14.00	2450
IE3-WU2R 355 L6	315	3023	315	995	IE3-	95.8	96.0	95.7	0.84	565	7.8	2.0	1.5	2.2	14.00	2450
IE3-WU2R 400 MY6	355	3407	355	995	IE3-	96.0	96	95.8	0.83	643	7.5	1.2	1.2	2.1	16.54	3000
IE3-WU2R 400 M6	400	3839	400	995		96.2	96.2	96	0.83	723	8.0	1.5	1.3	2.5	16.54	3000
IE3-WU2R 400 MX6	450	4314	450	996		96.0	96	95.8	0.84	805	7.6	1.5	***	2.2	18.44	3100
IE3-WU2R 400 L6	500	4794	500	996		96.4	96.4	96.4	0.82	1023	7.5	1.7	***	2.2	20.63	3320

*** upon request

Three-phase motors with squirrel-cage rotor, Premium Efficiency IE3 for converter-fed operation without filter up to 500 V

with surface cooling, duty type S8, S9
for rated voltage, thermal class 155 (F), degree of protection IP 55, 50 Hz

Motor selection data													Design point 400 V, 50 Hz			
Type	P _B M _B Converter		P _B Mains	n _B rpm	IE3-	η _B (IEC/EN 60034-2)			cosφ _B	I _B 400 V A	I _A /I _B	M _A /M _B	M ₂ /M _B	M _K /M _B	J kgm ²	m kg
	kW	Nm				100 %	75 %	50 %								
Synchronous speed 750 rpm – 8-pole version																
IE3-WU1R 71 G8	0.12	1.67	0.12	685	IE3-	50.7	48.8	43	0.64	0.48	2.6	1.7	1.7	2	0.0013	9.9
IE3-WU2R 80 K8	0.18	2.53	0.18	680	IE3-	58.7	56.3	49.8	0.61	0.73	2.6	1.6	1.6	2	0.00175	12
IE3-WU1R 80 G8	0.25	3.39	0.25	705	IE3-	64.1	64.3	58.4	0.59	0.93	3	1.4	1.4	2.1	0.003	14
IE3-WU2R 90 SY8	0.37	5.01	0.37	705	IE3-	69.3	67	61.2	0.56	1.39	3.1	1.6	1.6	2.2	0.00375	18.5
IE3-WU1R 90 L8	0.55	7.50	0.55	700	IE3-	73.0	70.6	66.3	0.64	1.72	3.6	1.8	1.8	2.3	0.0072	26
IE3-WU1R 100 LY8	0.75	10.1	0.75	710	IE3-	75.0	74.1	70.0	0.64	2.21	4.2	2.0	2.0	2.7	0.009	28
IE3-WU1R 100 LV8	1.1	***	1.1	***	IE3-	77.7	***	***	***	***	***	***	***	***	0.009	35
IE3-WU1R 112 M8	1.5	20.5	1.5	700	IE3-	79.7	78.7	76	0.65	4.25	3.8	1.6	1.5	2.1	0.0155	48
IE3-WU1R 132 S8	2.2	29	2.2	725	IE3-	84.4	84.5	82.4	0.7	5.4	4.1	1.6	1.5	2.3	0.043	80
IE3-WU1R 132 M8	3	40	3	720	IE3-	83.5	83.5	81.4	0.72	7	3.9	1.6	1.4	2.1	0.043	74
IE3-WU1R 160 M8	4	52	4	735	IE3-	87	86.7	83.8	0.71	9.4	5.4	2.5	2.2	2.9	0.113	119
IE3-WU1R 160 MX8	5.5	72	5.5	730	IE3-	87.5	87.5	85.6	0.73	12.5	4.7	1.9	1.7	2.5	0.145	143
IE3-WU1R 160 L8	7.5	98	7.5	730	IE3-	87.9	87.6	85.6	0.73	17	5.1	2.1	1.8	2.7	0.166	155
IE3-WU1R 180 L8	11	143	11	733	IE3-	89.3	89	87.1	0.75	23.5	5.4	2.1	1.9	2.8	0.228	175
IE3-WU1R 200 L8	15	196	15	730	IE3-	89.6	90	89	0.80	30	5.3	1.8	1.7	2.5	0.324	235
IE3-WU1R 225 S8	18.5	242	18.5	730	IE3-	90.1	***	***	***	***	***	***	***	***	0.514	310
IE3-WU1R 225 M8	22	286	22	735	IE3-	91.5	91.6	90.6	0.79	44	5.7	2.3	2	2.5	0.825	360
IE3-WU1R 250 M8	30	391	30	732	IE3-	91.3	91.9	91.4	0.81	58.5	5.4	2	1.8	2.3	0.92	420
IE3-WU1R 280 S8	37	479	37	738	IE3-	92	92	90.8	0.78	74.5	5.9	2.3	1.8	2.4	1.55	555
IE3-WU1R 280 M8	45	581	45	740	IE3-	93	93	92.4	0.78	89.5	6.5	1.7	1.5	2.4	2.63	700
IE3-WU2R 315 S8	55	708	55	742	IE3-	93.3	93.3	92.4	0.78	109	7.0	1.9	1.7	2.5	3.33	805
IE3-WU1R 315 M8	75	742	75	965	IE3-	93.8	94.2	93.8	0.81	142	7.0	1.9	1.7	2.3	5.55	1120
IE3-WU1R 315 MX8	90	1157	90	743	IE3-	94.3	94.4	93.6	0.8	172	7.9	2.4	2.0	2.7	6	1185
IE3-WU1R 315 MY8	110	1419	110	740	IE3-	93.8	94.0	93.8	0.82	206	6.5	1.9	1.5	2.1	6.76	1250
IE3-WU1R 315 L8	132	1703	132	740	IE3-	94.2	94.2	93.5	0.8	253	8.0	2.4	1.9	2.7	8.71	1450
IE3-WU1R 355 MY8	145	1859	145	745	IE3-	94.3	94.3	94.0	0.82	299	6.6	1.2	1.0	2.6	9.3	1700
IE3-WU1R 355 M8	180	2307	180	745	IE3-	94.7	94.9	94.2	0.81	376	7.0	1.0	1.0	2.7	9.5	1890
IE3-WU2R 355 MX8	220	2820	220	745	IE3-	94.6	94.4	93.5	0.68	561	5.2	1.4	1.3	2.0	13.40	2300
IE3-WU2R 355 L8	250	3204	250	745	IE3-	95.0	95.0	95.0	0.73	656	5.7	2.0	1.5	2.2	15.80	2450
IE3-WU2R 355 LX8	315	4048	315	743	IE3-	94.6	***	***	***	***	***	***	***	***	15.80	2400
IE3-WU2R 400 M8	315	4038	355	745	IE3-	95.0	95.0	95.0	0.74	729	6.5	1.5	1.3	1.8	17.94	2800
IE3-WU2R 400 MX8	355	4550	400	745	IE3-	95.6	95.5	95.0	0.69	875	5.6	1.3	1.0	2.0	19.99	3170
IE3-WU2R 400 L8	400	5127	450	745	IE3-	95.0	95.0	95.0	0.74	924	6.0	1.5	1.3	1.8	22.34	3320

*** upon request

Three-phase motors with squirrel-cage rotor, High Efficiency IE2 for converter-fed operation without filter up to 500 V



with surface cooling, duty type S8, S9
for rated voltage, thermal class 155 (F), degree of protection IP 55, 50 Hz

Motor selection data														Design point 400 V, 50 Hz		
Type	P _B	M _B	P _B	n _B	η _B			cosφ _B	I _B	I _A /I _B	M _A /M _B	M _S /M _B	M _K /M _B	J	m	
	Converter kW	Nm	Mains kW	rpm	(IEC/EN 60034-2) 100 % 75 % 50 %			-	400 V A	-	-	-	-	kgm ²	kg	
Synchronous speed 3000 rpm – 2-pole version																
IE2-WU2R 56 G2	0.12	0.40	0.12	2830	IE2-	53.6	69.6	60.8	0.77	0.32	4.5	2.1	2.1	2.3	0.00013	4.5
IE2-WU2R 63 K2	0.18	0.62	0.18	2790	IE2-	60.4	63.1	57.6	0.76	0.51	4.1	1.9	1.9	2.2	0.00013	4.9
IE2-WU2R 63 G2	0.25	0.86	0.25	2775	IE2-	64.8	66.7	61.9	0.8	0.67	4.2	1.9	1.9	2.2	0.00015	5.2
IE2-WU2R 71 K2	0.37	1.28	0.37	2750	IE2-	69.5	70.8	69.4	0.84	0.89	4.6	1.8	1.8	2.1	0.00025	6.7
IE2-WU2R 71 G2	0.55	1.89	0.55	2775	IE2-	74.1	75.0	72	0.81	1.32	5.1	2.3	2.1	2.6	0.00032	7.6
IE2-WU2R 80 K2	0.75	2.54	0.75	2825	IE2-	77.4	77.1	72.9	0.81	1.72	5.9	2.4	2.4	2.4	0.00057	10.7
IE2-WU2R 80 G2	1.1	3.75	1.1	2805	IE2-	79.6	78.7	76.4	0.85	2.36	5.6	1.9	1.8	2.2	0.00072	11.5
IE2-WU2R 90 S2	1.5	4.99	1.5	2870	IE2-	81.3	82.0	79.4	0.8	3.30	6.6	3.2	3.2	3.7	0.00132	16
IE2-WU2R 90 L2	2.2	7.37	2.2	2850	IE2-	83.2	81.5	***)	0.85	4.55	7.5	2.8	2.3	2.9	0.0017	19.0
IE2-WU2R 100 LY2	3	9.97	3	2875	IE2-	84.6	85.1	83.6	0.85	6	7.4	2.6	2.3	3.3	0.0045	28.5
IE2-WU1R 112 M2	4	13.20	4	2900	IE2-	85.8	86.3	***)	0.81	8.4	7	2.2	2.1	2.9	0.0045	32.0
IE2-WU1R 132 SY2T	5.5	18.20	5.5	2890	IE2-	87.0	86.6	***)	0.84	11	7.5	2.4	2.2	3	0.0055	40.0
IE2-WU1R 132 SX2T	7.5	24.90	7.5	2880	IE2-	88.1	88.0	***)	0.84	14.8	6.3	1.5	1.2	2.6	0.0068	48.0
IE2-WU1R 132 S2	5.5	18.0	5.5	2915	IE2-	88.7	88.7	87.8	0.85	10.5	6.8	1.9	1.5	3.0	0.0110	57
IE2-WU1R 132 SX2	7.5	24.5	7.5	2920	IE2-	89.0	89.6	88.8	0.89	13.5	6.7	2	1.7	2.9	0.0168	75
IE2-WU1R 160 M2	11.0	35.7	11.0	2940	IE2-	91.0	91.7	91.3	0.89	19.5	6.5	1.7	1.4	2.4	0.0258	125
IE2-WU1R 160 MX2	15.0	48.8	15.0	2935	IE2-	90.6	91.3	91.1	0.91	26.5	6.7	1.8	1.5	2.6	0.0675	140
IE2-WU1R 160 L2	18.5	60.2	18.5	2935	IE2-	90.9	91.9	92.1	0.90	32.5	7.2	2	1.6	2.8	0.0675	140
IE2-WU1R 180 M2	22	71	22	2940	IE2-	91.6	91.6	92.3	0.90	38.5	6.4	1.6	1.3	2.5	0.105	173
IE2-WU1R 200 L2	30	97	30	2950	IE2-	92.5	93.2	92.9	0.90	52	7.1	1.9	1.6	3	0.128	210
IE2-WU1R 200 LX2	37	120	37	2945	IE2-	92.5	92.5	92.5	0.91	64	7.2	1.9	1.5	2.7	0.154	233
IE2-WU2R 200 LX2	37	120	37	2955	IE2-	92.9	93.2	92.5	0.90	64	8.1	2.3	1.8	3.3	0.154	233
IE2-WU1R 225 M2	45	146	45	2950	IE2-	92.9	92.2	91.2	0.87	80.5	6.9	1.7	1.1	2.7	0.220	295
IE2-WU1R 250 M2	55	178	55	2956	IE2-	93.2	93.6	92.6	0.89	95.5	7.6	1.9	1.5	2.6	0.375	385
IE2-WU1R 280 S2	74	238	74	2970	IE2-	94.1	94.0	91.5	0.90	126	8.1	2.1	1.8	3.1	0.65	500
IE2-WU1R 280 M2	87	280	87	2970	IE2-	94.4	94.1	91.9	0.91	146	7.7	2	1.7	2.8	0.68	550
IE2-WU1R 315 S2	110	353	110	2975	IE2-	94.5	94.3	93.3	0.89	189	8.0	1.3	1.2	2.4	1.21	730
IE2-WU1R 315 M2	132	424	132	2975	IE2-	95.0	94.8	94.5	0.89	225	9.2	1.4	1.2	2.4	1.44	820
IE2-WU1R 315 MX2	160	514	160	2973	IE2-	94.8	94.8	94.8	0.89	274	8.2	1.3	1.3	2.4	1.76	955
IE2-WU1R 315 MY2	200	640	200	2983	IE2-	95.4	95.0	94.3	0.88	344	9.4	2.8	2.0	3.0	2.82	1200
IE2-WU1R 315 L2	220	704	250	2984	IE2-	95.4	95.4	95.4	0.92	411	9.0	2.3	1.2	2.3	3.66	1450
IE2-WU1R 315 LX2	270	864	315	2985	IE2-	95.4	95.4	95.0	0.92	518	8.5	2.8	1.6	2.5	4.43	1700
IE2-WU2R 355 M2	330	1056	355	2985	IE2-	95.5	95.5	95.5	0.92	583	7.7	1.9	1.5	3.8	4.20	2000
IE2-WU2R 355 MX2	355	1134	400	2990	IE2-	95.5	95.5	95.5	0.91	664	9.4	1.8	1.0	3.0	4.50	2200
IE2-WU2R 355 LY2	425	1360	450	2985	IE2-	95.5	95.5	95.5	0.92	739	7.0	1.3	0.9	2.4	7.10	2400
IE2-WU2R 355 L2	425	1360	500	2985	IE2-	95.5	95.5	95.5	0.92	821	8.5	1.5	1.2	2.5	7.10	2400

***) upon request

Three-phase motors with squirrel-cage rotor, High Efficiency IE2 for converter-fed operation without filter up to 500 V

IE2 EU REGULATION 640/2009
USE WITH VARIABLE SPEED DRIVE ONLY!

with surface cooling, duty type S8, S9
for rated voltage, thermal class 155 (F), degree of protection IP 55, 50 Hz

Motor selection data													Design point 400 V, 50 Hz			
Type	P _B	M _B	P _B	n _B	IE2-	η _B (IEC/EN 60034-2)			cosφ _B	I _B	I _A /I _B	M _A /M _B	M _S /M _B	M _K /M _B	J	m
	Converter kW	Nm	Mains kW	rpm		100 %	75 %	50 %	-	400 V A	-	-	-	-	kgm ²	kg
Synchronous speed 1500 rpm – 4-pole version																
IE2-WU2R 63 K4	0.12	0.83	0.12	1380	IE2-	59.1	55.7	46.8	0.69	0.45	2.8	1.6	1.6	2.1	0.00019	4.8
IE2-WU1R 63 GY4	0.18	1.23	0.18	1395	IE2-	64.7	66.3	61.3	0.72	0.54	3.5	1.7	1.7	2.2	0.0004	6.3
IE2-WU2R 71 K4	0.25	1.71	0.25	1395	IE2-	68.5	68.1	63.8	0.70	0.73	3.9	2.1	2.1	2.5	0.0005	7.8
IE2-WU1R 71 GY4	0.37	2.48	0.37	1425	IE2-	72.7	72.2	68.6	0.69	1.00	4.9	2.4	2.4	3.0	0.00087	9.9
IE2-WU2R 80 K4	0.55	3.71	0.55	1415	IE2-	77.1	77.1	73.9	0.72	1.42	4.9	2.6	2.5	2.8	0.00107	11.7
IE2-WU1R 80 GY4	0.75	5.01	0.75	1430	IE2-	79.6	78.0	74.7	0.80	1.73	5.7	2.2	2.2	3.1	0.00207	14.5
IE2-WU2R 90 S4	1.1	7.32	1.1	1435	IE2-	81.4	80.1	77.0	0.76	2.60	6.3	3.0	3.0	3.8	0.0028	18.5
IE2-WU1R 90 LW4	1.5	9.95	1.5	1440	IE2-	82.8	83.8	81.4	0.76	3.40	6.5	2.7	2.7	3.6	0.004	23
IE2-WU1R 100 S4	2.2	14.5	2.2	1445	IE2-	84.3	84.9	82.7	0.79	4.67	7.3	2.7	2.5	3.1	0.00725	30
IE2-WU1R 100 LW4	3.0	19.8	3.0	1445	IE2-	85.5	85.8	83.6	0.79	6.33	7.8	3.0	2.9	3.6	0.009	36
IE2-WU1R 112 MZ4	4.0	26.4	4.0	1445	IE2-	86.6	86.8	84.9	0.80	8.30	8.2	2.8	2.6	3.6	0.013	50
IE2-WU2R 315 SY4	5.5	36.2	5.5	1450	IE2-	87.7	87.7	86.4	0.84	10.80	8.0	2.5	2.3	3.8	0.015	***
IE2-WU1R 112 M4	4.0	26.2	4.0	1460	IE2-	87.6	88.0	86.9	0.86	7.6	8.3	2.6	2.3	3.9	0.017	56
IE2-WU2R 132 S4	5.5	35.9	5.5	1465	IE2-	87.7	87.1	84.7	0.79	11.3	9.3	3.0	2.8	4.9	0.020	64
IE2-WU1R 132 S4	5.5	35.9	5.5	1465	IE2-	87.7	87.7	86.2	0.86	10.5	6.6	2	1.6	2.8	0.035	87
IE2-WU1R 132 M4	7.5	48.7	7.5	1470	IE2-	88.8	88.8	87.3	0.81	15	7.9	2.3	1.8	3.6	0.035	88
IE2-WU1R 160 M4	11.0	71	11.0	1475	IE2-	89.8	89.5	87.9	0.83	21.5	7.8	2.7	2.1	3.2	0.078	122
IE2-WU2R 160 M4	11	71	11	1470	IE2-	90.3	90.3	88.9	0.78	22.5	7.8	2.4	2.1	3.9	0.043	105
IE2-WU1R 160 L4	15.0	97	15.0	1480	IE2-	92.0	92.0	90.6	0.84	28	9.1	3	2.5	3.9	0.115	160
IE2-WU2R 160 L4	15	97	15	1475	IE2-	91.2	91.5	90.6	0.83	28.5	8.5	3.3	2.5	3.6	0.115	161
IE2-WU1R 180 M4	18.5	120	18.5	1475	IE2-	91.9	92.2	91.4	0.84	34.5	7	2	1.7	2.9	0.168	207
IE2-WU2R 180 M4	18.5	120	18.5	1470	IE2-	91.2	90.6	89.3	0.78	37.5	6.4	2	1.6	2.8	0.138	176
IE2-WU1R 180 L4	22	142	22	1475	IE2-	91.8	91.7	90.4	0.80	43	7.5	2.3	2	3.3	0.168	215
IE2-WU1R 200 L4	30	194	30	1480	IE2-	92.3	91.8	90.6	0.79	59.5	7.2	2.1	1.8	3	0.275	277
IE2-WU1R 225 S4	37	240	37	1475	IE2-	92.7	92.8	91.0	0.82	70	7	2	1.7	2.7	0.313	313
IE2-WU1R 225 M4	45	290	45	1483	IE2-	93.1	93.0	91.1	0.84	83	7.9	2.3	1.9	2.4	0.525	390
IE2-WU1R 225 M4	45	291	45	1475	IE2-	93.1	92.9	92.1	0.80	87	7.6	2.6	1.9	3.1	0.356	346
IE2-WU1R 250 M4	55	354	55	1485	IE2-	94.0	94.1	92.5	0.84	101	8	2	1.7	2.3	0.95	535
IE2-WU2R 250 M4	55	356	55	1477	IE2-	93.9	93.8	93.7	0.82	103	7.5	2.4	1.9	2.4	0.62	435
IE2-WU1R 280 S4	75	482	75	1485	IE2-	94.2	94.4	92.1	0.84	137	7.2	1.8	1.6	2.1	0.95	550
IE2-WU1R 280 M4	90	580	90	1483	IE2-	94.3	94.5	94.0	0.84	164	7.6	1.8	1.6	2.3	1.10	610
IE2-WU1R 315 S4	110	707	110	1485	IE2-	94.8	94.8	94.0	0.82	204	8.5	1.8	1.5	2.7	1.96	760
IE2-WU1R 315 M4	132	849	132	1484	IE2-	95.0	95.0	94.5	0.83	242	8.2	1.8	1.6	2.3	2.27	850
IE2-WU1R 315 MX4	160	1031	160	1482	IE2-	95.0	95.0	94.5	0.84	289	7.4	1.6	1.4	2.2	2.73	975
IE2-WU1R 315 MY4	200	1282	200	1490	IE2-	95.1	95.1	94.5	0.87	349	8.5	1.8	1.6	2.5	4.82	1270
IE2-WU1R 315 L4	250	1602	250	1490	IE2-	95.4	95.4	95.3	0.88	430	9.0	2.2	1.5	2.7	5.93	1450
IE2-WU1R 315 LX4	285	1827	315	1490	IE2-	95.4	95.4	95.0	0.88	542	9.0	2.4	1.6	2.6	6.82	1630
IE2-WU2R 355 M4	355	2271	355	1493	IE2-	95.5	95.5	95.0	0.87	617	8.0	1.3	1.0	2.7	7.90	2150
IE2-WU2R 355 MX4	390	2493	400	1494	IE2-	95.5	95.5	95.5	0.88	687	8.5	1.3	1.0	3.0	9.50	2400
IE2-WU2R 355 LY4	430	2745	450	1496	IE2-	95.5	95.5	95.5	0.86	791	8.5	1.4	0.8	2.9	10.00	2500
IE2-WU2R 355 L4	430	2745	500	1496	IE2-	95.5	95.5	95.5	0.84	900	8.0	1.2	0.9	3.0	10.00	2500

*** upon request

Three-phase motors with squirrel-cage rotor, High Efficiency IE2 for converter-fed operation without filter up to 500 V



with surface cooling, duty type S8, S9
for rated voltage, thermal class 155 (F), degree of protection IP 55, 50 Hz

Motor selection data														Design point 400 V, 50 Hz		
Type	P _B	M _B	P _B	n _B	IE2-	η _B (IEC/EN 60034-2)			cosφ _B	I _B	I _A /I _B	M _A /M _B	M _S /M _B	M _K /M _B	J	m
	Converter kW	Nm	Mains kW	rpm		100 %	75 %	50 %	-	400 V A	-	-	-	-	kgm ²	kg
Synchronous speed 1000 rpm – 6-pole version																
IE2-WU2R 63 G6	0.12	1.3	0.12	880	IE2-	50.6	48.0	***)	0.56	0.6	2.5	2.0	2.0	2.3	0.00027	5.7
IE2-WU2R 71 K6	0.18	1.9	0.18	920	IE2-	56.6	54.4	48.5	0.52	0.8	2.9	2.0	2.0	2.3	0.0006	8.3
IE2-WU2R 71 G6	0.25	2.6	0.25	915	IE2-	61.6	56.5	***)	0.55	1.1	2.9	2.0	2.0	2.2	0.0006	8.3
IE2-WU2R 80 K6	0.37	3.8	0.37	935	IE2-	67.6	68.5	63.3	0.65	1.17	3.7	2.1	2.1	2.6	0.00175	12.5
IE2-WU1R 80 GY6	0.55	5.6	0.55	945	IE2-	73.1	72.6	68.4	0.67	1.6	3.8	1.9	1.9	2.4	0.00325	15.0
IE2-WU2R 90 S6	0.75	7.6	0.75	945	IE2-	75.9	***)	***)	0.67	2.12	4.0	1.8	1.8	2.4	0.00425	19.0
IE2-WU1R 90 LW6	1.1	11.0	1.1	955	IE2-	78.1	78.0	75.1	0.69	2.95	4.7	2.5	2.4	2.8	0.00625	24.0
IE2-WU2R 100 L6	1.5	15.1	1.5	950	IE2-	79.8	80.4	77.6	0.7	3.85	5.1	2.5	2.4	3.0	0.0072	30.0
IE2-WU1R 112 MX6	2.2	21.9	2.2	960	IE2-	81.8	***)	***)	0.65	5.9	6.4	3.0	2.9	3.7	***)	37.0
IE2-WU1R 112 SX6T	3.0	30.0	3.0	955	IE2-	83.3	83.1	80.5	0.73	7.1	7.0	3.2	3.1	4.0	0.0165	52.0
IE2-WU1R 132 S6	3.0	29.8	3.0	963	IE2-	84.9	85.2	83.9	0.80	6.4	6.0	2.0	1.3	3.0	0.023	55
IE2-WU2R 132 M6	4	40	4	955	IE2-	85.1	86.0	85.2	0.82	8.3	5.7	2.1	2.0	2.9	0.029	66
IE2-WU1R 132 M6	4.0	39.6	4.0	965	IE2-	85.5	85.5	83.8	0.79	8.5	5.1	1.8	1.6	2.4	0.043	76
IE2-WU1R 132 MX6	5.5	54.1	5.5	970	IE2-	86.1	85.5	82.4	0.77	12	5.7	2.2	1.7	2.7	0.053	85
IE2-WU1R 160 M6	7.5	73	7.5	975	IE2-	87.4	88.1	86.0	0.81	15.5	6.3	2.5	2.1	2.9	0.113	118
IE2-WU2R 160 M6	7.5	74	7.5	970	IE2-	87.5	87.6	85.9	0.79	15.5	5.9	2.1	1.8	2.9	0.053	103
IE2-WU1R 160 L6	11.0	108	11.0	970	IE2-	88.7	87.9	86.3	0.85	21	5.8	2.2	1.9	2.7	0.145	135
IE2-WU2R 160 L6	11.0	108	11.0	975	IE2-	88.9	88.8	87.0	0.81	22	6.8	2.7	2.4	3.1	0.166	155
IE2-WU1R 180 L6	15.0	147	15.0	975	IE2-	89.7	88.8	86.7	0.84	28.5	6.2	2.1	1.8	2.8	0.228	185
IE2-WU2R 180 L6	15	148	15	970	IE2-	89.7	88.8	87.8	0.83	29	5.6	2.3	1.7	2.6	0.166	157
IE2-WU1R 200 L6	16.5	161	16.5	980	IE2-	90.9	88.0	85.9	0.81	32.5	7.3	2.7	2.4	3.4	0.268	208
IE2-WU1R 200 LX6	22	214	22	980	IE2-	90.9	90.2	88.5	0.86	40.5	6.4	2.2	1.8	2.7	0.443	272
IE2-WU2R 200 LX6	22	215	22	975	IE2-	90.9	89.9	88.5	0.84	41.5	6.7	2.4	2	3	0.324	238
IE2-WU1R 225 M6	30	291	30	985	IE2-	92.0	91.5	90.0	0.86	54.5	7.3	2.5	2.2	2.9	0.825	365
IE2-WU2R 225 M6	30	294	30	975	IE2-	91.7	91.4	90.6	0.87	54.5	6.7	2.3	1.9	2.8	0.514	308
IE2-WU1R 250 M6	37	359	37	985	IE2-	92.2	91.5	89.2	0.85	68	6.4	2.1	1.7	2.4	1.28	480
IE2-WU2R 250 M6	37	361	37	979	IE2-	92.2	92.3	91.8	0.86	67.5	6.6	2.7	2	2.6	0.92	407
IE2-WU1R 280 S6	45	437	45	983	IE2-	93.0	92.7	92.4	0.87	80.5	6.5	2.2	1.7	2.4	1.48	560
IE2-WU1R 280 M6	55	531	55	990	IE2-	93.6	93.5	93.0	0.85	100	7.6	2	1.5	2.5	2.63	710
IE2-WU1R 315 S6	75	723	75	990	IE2-	93.9	93.7	93.5	0.87	133	7.8	1.9	1.5	2.5	3.33	804
IE2-WU1R 315 M6	90	868	90	990	IE2-	94.0	94.0	93.5	0.88	157	7.5	1.8	1.5	2.5	3.60	865
IE2-WU1R 315 MX6	110	1061	110	990	IE2-	94.3	94.3	94.0	0.87	194	7.5	1.8	1.4	2.3	6.67	1210
IE2-WU1R 315 MY6	132	1273	132	990	IE2-	94.6	94.3	94.0	0.87	231	7.5	1.9	1.4	2.2	6.67	1250
IE2-WU1R 315 L6	160	1543	160	990	IE2-	94.8	94.5	93.5	0.88	277	7.5	2.0	1.5	2.4	8.60	1430
IE2-WU1R 315 LX6	185	1785	200	990	IE2-	95.0	95.0	94.5	0.86	353	7.0	1.9	1.5	2.2	8.60	1460
IE2-WU2R 355 M6	250	2402	250	994	IE2-	95.0	95.0	94.7	0.84	452	7.0	1.5	1.2	2.2	8.20	1850
IE2-WU2R 355 MX6	300	2879	315	995	IE2-	95.2	95.2	95.2	0.86	555	7.0	1.3	1.1	2.2	12.1	2200
IE2-WU2R 355 LY6	315	3023	355	995	IE2-	95.0	95.0	94.0	0.77	700	7.5	1.8	1.5	2.6	14.0	2400

***) upon request

Three-phase motors with squirrel-cage rotor, High Efficiency IE2 for converter-fed operation without filter up to 500 V

IE2 EU REGULATION 640/2009
USE WITH VARIABLE SPEED DRIVE ONLY!

with surface cooling, duty type S8, S9
for rated voltage, thermal class 155 (F), degree of protection IP 55, 50 Hz

Motor selection data													Design point 400 V, 50 Hz			
Type	P _B	M _B	P _B	n _B	IE2-	η _B (IEC/EN 60034-2)			cosφ _B	I _B	I _A /I _B	M _A /M _B	M _S /M _B	M _K /M _B	J	m
	Converter kW	Nm	Mains kW	rpm		100 %	75 %	50 %	-	400 V A	-	-	-	-	kgm ²	kg
Synchronous speed 750 rpm – 8-pole version																
IE2-WU2R 71 G8	0.1	1.7	0.1	670	IE2-	39.8	41.3	***)	0.51	0.73	2.30	1.80	1.80	2.10	0.0006	8
IE2-WU2R 80 K8	0.2	2.5	0.2	690	IE2-	45.9	53.8	***)	0.59	0.78	2.80	2.00	2.00	2.20	0.0013	11
IE2-WU2R 80 G8	0.3	3.4	0.3	695	IE2-	50.6	54.0	***)	0.56	1.12	3.00	2.30	2.30	2.50	0.00175	12
IE2-WU2R 90 S8	0.4	5.1	0.4	700	IE2-	56.1	56.3	***)	0.54	1.60	3.00	1.90	1.90	2.10	0.003	15
IE2-WU2R 90 L8	0.6	7.6	0.6	695	IE2-	61.7	61.8	***)	0.60	2.04	3.20	1.90	1.90	2.20	0.00375	18
IE2-WU2R 100 L8	0.8	10.2	0.8	705	IE2-	66.2	63.0	***)	0.60	2.90	3.30	1.80	1.80	2.20	0.00625	23
IE2-WU1R 100 LY8	1.1	14.9	1.1	705	IE2-	70.8	72.5	***)	0.67	3.25	4.00	2.00	2.00	2.40	0.009	28
IE2-WU1R 112 M8	1.5	20.3	1.5	705	IE2-	74.1	73.6	70.1	0.62	4.50	4.20	2.00	2.00	2.70	0.0139	37
IE2-WU1R 132 S8	2.2	29.2	2.2	720	IE2-	81.7	81.0	77.5	0.65	6	4.8	2.2	2.0	3.2	0.0180	55
IE2-WU2R 132 M8	3.0	40.4	3.0	710	IE2-	80.0	80.8	79.0	0.73	7.4	4.9	1.9	1.9	2.7	0.0290	65
IE2-WU1R 132 M8	3.0	39.8	3.0	720	IE2-	82.7	83.0	81.3	0.74	7.1	3.9	1.6	1.3	1.9	0.0430	74
IE2-WU1R 160 M8	4.0	53.2	4.0	718	IE2-	84.2	83.7	81.9	0.72	9.5	4.6	1.6	***)	2.5	0.0530	86
IE2-WU1R 160 MX8	5.5	72	5.5	730	IE2-	86.9	86.6	84.1	0.72	12.5	4.8	2.1	1.8	2.6	0.1130	115
IE2-WU2R 160 MX8	5.5	73	5.5	715	IE2-	83.9	84.0	81.9	0.71	13.5	4.3	1.7	1.5	2.5	0.0530	103
IE2-WU1R 160 L8	7.5	99	7.5	725	IE2-	86.9	87.6	86.6	0.76	16.5	4.5	1.8	1.6	2.3	0.1450	138
IE2-WU1R 180 L8	11.0	144	11.0	727	IE2-	88.2	88.2	86.7	0.78	23	4.9	1.8	1.6	2.4	0.2280	175
IE2-WU2R 180 L8	11	144	11	730	IE2-	87.9	87.4	85.2	0.67	25.5	4.3	1.9	1.6	2.3	0.1660	157
IE2-WU1R 200 L8	15.0	197	15.0	727	IE2-	88.2	88.1	86.4	0.77	32	4.9	1.9	1.7	2.3	0.2680	200
IE2-WU1R 225 S8	18.5	242	18.5	730	IE2-	89.6	89.4	87.2	0.78	38	5.4	2.1	2.0	2.8	0.440	265
IE2-WU2R 225 S8	18.5	240	18.5	735	IE2-	90.7	90.7	89.4	0.8	37	6.1	2.1	1.9	2.9	0.514	305
IE2-WU1R 225 M8	22	287	22	733	IE2-	90.6	89.4	89.9	0.78	45	5.6	2.2	1.8	2.6	0.825	380
IE2-WU2R 225 M8	22	286	22	735	IE2-	90.3	90.3	88.7	0.77	45.5	6.1	2.2	2.0	2.9	0.514	307
IE2-WU2R 250 M8	30	391	30	732	IE2-	91.5	91.7	90.9	0.77	61.5	5.6	2.3	2.0	2.5	0.950	405
IE2-WU1R 280 S8	37	479	37	737	IE2-	90.8	91.3	90.7	0.80	73.5	4.9	1.9	1.5	2.0	1.35	480
IE2-WU1R 280 M8	45	581	45	740	IE2-	91.8	91.8	90.7	0.77	92	5.8	2.3	1.8	2.5	1.55	535
IE2-WU1R 315 S8	55	710	55	740	IE2-	92.2	92.2	92.2	0.80	108	6.3	1.8	1.5	2.3	2.63	715
IE2-WU1R 315 M8	75	968	75	740	IE2-	92.7	92.5	92.5	0.81	144	6.0	2.1	1.4	2.1	3.33	805
IE2-WU1R 315 MX8	90	1161	90	740	IE2-	93.0	93.0	93.0	0.79	177	6.5	1.7	1.5	2.2	3.6	850
IE2-WU1R 315 MY8	110	1420	110	740	IE2-	93.4	93.4	93.4	0.82	207	6.5	1.8	1.6	2.2	6	1080
IE2-WU1R 315 L8	132	1704	132	740	IE2-	93.2	93.2	93.2	0.83	246	6.0	1.5	1.4	2.2	6.76	1250
IE2-WU1R 315 LX8	145	1871	160	740	IE2-	93.9	93.9	93.8	0.80	307	7.2	2.2	1.8	2.5	8.71	1430
IE2-WU2R 355 M8	200	2571	200	743	IE2-	94.5	94.1	91.5	0.77	397	***)	***)	***)	***)	9.5	1850
IE2-WU2R 355 MX8	225	2884	250	745	IE2-	94.0	94.0	94.0	0.83	463	7.0	1.2	1.0	2.6	13.4	2200
IE2-WU2R 355 LY8	230	2956	280	743	IE2-	94.3	94.3	94.3	0.78	549	7.2	1.3	1.0	2.7	15.8	2400

***) upon request

Three-phase motors with squirrel-cage rotor
Special insulation for converter-fed operation without filter up to 500 V

with surface cooling, duty type S8, S9
 for rated voltage, thermal class 155 (F), degree of protection IP 55, 50 Hz

Motor selection data, mains-fed operation												Design point 500 V, 50 Hz	
Type IEC/DIN	Type Progressive	P _B	M _B	n _B	η _B (IEC/EN 60034-2)	cosφ _B	I _B 500 V	I _M /I _B	M _K /M _B	M _S /M _B	M _R /M _B	J	m
		kW	Nm	rpm	%	-	A	-	-	-	-	kgm ²	kg
Synchronous speed 3000 rpm – 2-pole version													
KU10 56 KU		0.09	0.3	2840	70	0.74	0.2	4.9	2.3	2.3	2.8	0.00013	4.4
KU1R 56 G2		0.12	0.4	2830	70.3	0.77	0.26	4.5	2.1	2.1	2.3	0.00013	4.5
KU1R 63 KU	KUOR 56 KU	0.18	0.62	2790	67	0.76	0.41	4.1	1.9	1.9	2.2	0.00013	4.9
KU1R 63 G2	KUOR 56 G2	0.25	0.85	2800	67.7	0.72	0.59	4.2	2.2	2.2	2.4	0.00015	5.2
KU1R 71 KU	KUOR 63 KU	0.37	1.27	2780	71.9	0.79	0.75	4.4	2.1	2.1	2.3	0.00025	6.7
KU1R 71 G2	KUOR 63 G2	0.55	1.89	2775	74.2	0.81	1.06	5.1	2.3	2.1	2.6	0.00032	7.6
KU1R 80 KU	KUOR 71 KU	0.75	2.54	2825	77.7	0.81	1.38	5.9	2.4	2.4	2.4	0.00057	10.7
KU1R 80 G2	KUOR 71 G2	1.1	3.71	2835	77.8	0.8	2.04	6	2.4	2.3	2.6	0.00072	11.5
KU1R 90 S2	KUOR 80 KU	1.5	5.04	2840	81.2	0.86	2.5	7	2.5	2.5	2.8	0.00132	16
KU1R 90 L2	KUOR 80 G2	2.2	7.37	2850	82.1	0.85	3.6	7.5	2.8	2.3	2.9	0.0017	19
KU1R 100 L2	KUOR 90 L2	3	10	2865	83.8	0.84	4.9	6.8	2.4	2.2	2.8	0.00275	25
KU1R 112 M2	KUOR 100 S2	4	13.2	2900	84.9	0.81	6.7	7	2.2	2.1	2.9	0.0045	32
KU1R 112 MX2	KUOR 100 L2	5.5	18.2	2890	85.9	0.84	8.8	7.5	2.4	2.2	3	0.0055	38
KU1R 132 S2T	KUOR 100 L2	5.5	18.2	2890	85.9	0.84	8.8	7.5	2.4	2.2	3	0.0055	40
KU1R 112 MV2	KUOR 100 LV2	7.5	24.9	2880	87.1	0.84	11.8	6.3	1.5	1.2	2.6	0.0068	46
KU1R 132 SX2T	KUOR 100 LV2	7.5	24.9	2880	87.1	0.84	11.8	6.3	1.5	1.2	2.6	0.0068	48
KU1R 132 S2	KUOR 112 MY2	5.5	18.4	2860	85.7	0.86	8.8	5.5	1.8	1.6	2.2	0.0081	52
KU1R 132 SX2	KUOR 112 M2	7.5	24.7	2900	87	0.86	11.6	6.6	1.8	1.3	2.5	0.011	57
KU1R 160 M2	KUOR 132 M2	11	36.2	2900	88.5	0.9	16	7	2.4	2	3	0.0258	81
KU1R 160 MX2	KUOR 160 S2	15	48.9	2930	89.4	0.9	21.6	7.1	2.2	1.7	2.9	0.0575	118
KU1R 160 L2	KUOR 160 M2	18.5	61	2920	90.5	0.92	25.6	7.2	2.1	1.6	2.8	0.0675	134
KU1R 180 M2	KUOR 180 S2	22	72	2935	91.8	0.92	30	6.8	1.7	1.4	2.6	0.105	165
KU1R 200 L2	KUOR 180 M2	30	97	2940	92.8	0.92	40.4	7.3	2	1.6	2.9	0.128	195
KU1R 200 LX2	KUOR 200 M2	37	120	2940	93	0.9	51.2	7	1.8	1.3	2.4	0.193	255
KU1R 225 M2	KUOR 200 L2	45	146	2940	93.7	0.91	60.8	7.5	1.8	1.4	2.7	0.22	290
KU1R 250 M2	KUOR 225 M2	55	178	2955	93.7	0.91	74.4	7.5	2	1.5	2.6	0.375	360
KU1R 280 S2	KUOR 250 S2	75	241	2970	94.6	0.92	99.2	7.5	2	1.6	2.6	0.65	490
KU1R 280 M2	KUOR 250 M2	90	289	2970	94.7	0.91	121	8.5	2.2	1.8	2.8	0.675	510
KU1R 315 S2	KUOR 280 S2	110	353	2975	95.4	0.91	146	8.5	1.5	1.3	2.5	1.21	720
KU1R 315 M2	KUOR 280 M2	132	424	2975	95.4	0.91	175	8.5	2	1.8	2.7	1.44	800
KU1R 315 MX2	KUOR 315 S2	160	514	2975	96	0.93	207	8.5	2	1.6	2.6	1.76	980
KU1R 315 MY2	KUOR 315 M2	200	643	2970	96	0.92	262	8.2	2.6	2	2.6	2.82	1170
KU1R 315 L2	KUOR 315 L2	250	803	2973	96.1	0.93	323	7.3	2.1	1.4	2	3.66	1460
KU1R 315 LX2	KUOR 315 LX2	315	1011	2975	96.7	0.92	409	7.4	2.4	1.4	2	4.43	1630
KU2R 355 MY2		315	1007	2988	96.8	0.88	427	8.6	1.25	1	3	4.1	1900
KU2R 355 M2		355	1138	2980	96.5	0.91	466	7.3	1.3	1	2.3	4.2	2000
KU2R 355 MX2		400	1280	2985	96.8	0.9	530	8.5	1.9	1.3	3.2	5.5	2200
KU2R 355 LY2		450	1441	2983	96.9	0.92	583	7.2	1.3	1	2.4	7.1	2400
KU2R 355 L2		500	1600	2985	97.2	0.92	646	8.2	1.75	0.9	2.6	7.1	2400

Motor selection data, converter-fed operation														Converter-fed operation 500 V				
Type IEC/DIN	Type Progressive	Converter input, 50 Hz			Setting range 1 : 2.5			Setting range 1 : 5			Setting range 1 : 10			I ₀	I _{max}	M _{max}	n _{max}	n _{maxFU}
		P _{50 Hz}	i _B	M _B	P _{1:2.5}	i _B	M _B	P _{1:5}	i _B	M _B	P _{1:10}	i _B	M _B					
		500 V			500 V			500 V			500 V							
		kW	A	Nm	kW	A	Nm	kW	A	Nm	kW	A	Nm	kW	A	Nm	rpm	rpm
Synchronous speed 3000 rpm – 2-pole version																		
KU10 56 KU		0.09		0.3													15000	5220
KU1R 56 G2		0.12		0.4													15000	5220
KU1R 63 KU	KUOR 56 KU	0.18		0.62	0.14		0.5	0.1	0.34	0.09		0.3				1	15000	5220
KU1R 63 G2	KUOR 56 G2	0.25		0.86	0.2		0.69	0.14	0.49	0.12		0.42				1.5	15000	5220
KU1R 71 KU	KUOR 63 KU	0.37		1.28	0.3		1.02	0.22	0.74	0.19		0.66				2.2	14000	5220
KU1R 71 G2	KUOR 63 G2	0.55		1.91	0.44		1.52	0.32	1.12	0.29		1				3.7	14000	5220
KU1R 80 KU	KUOR 71 KU	0.75		2.5	0.59		2	0.43	1.44	0.34		1.2				4.6	13000	5220
KU1R 80 G2	KUOR 71 G2	1.1		3.7	0.88		3	0.64	2.2	0.51		1.76				7.4	13000	5220
KU1R 90 S2	KUOR 80 KU	1.5		5	1.2		4	0.96	3.2	0.72		2.4				10	11000	5220
KU1R 90 L2	KUOR 80 G2	2.2		7.4	1.76		5.9	1.44	4.7	1.07		3.6				16	11000	5220
KU1R 100 L2	KUOR 90 L2	3		10	2.4		8	2	6.6	1.52		5.2				21	10000	5220
KU1R 112 M2	KUOR 100 S2	4		13.2	3.2		10.6	2.8	9.4	2.2		7				29	7000	5220
KU1R 112 MX2	KUOR 100 L2	5.5		18.20	5.5		18.1	4.7	15.5	3.9		13				41	7000	5220
KU1R 132 S2T	KUOR 100 L2	5.5		18.2	4.4		14.5	3.8	12.4	3.1		10.4				41	7000	5220
KU1R 112 MV2	KUOR 100 LV2	7.5		25.00	7.5		24.9	6.5	21.7	5.4		17.9				49	7000	5220
KU1R 132 SX2T	KUOR 100 LV2	7.5		25	6		19.9	5.2	17.4	4.3		14.3				49	7000	5220
KU1R 132 S2	KUOR 112 MY2	5.2	8.3	17.2	5.2	8.3	17.2	5.1	16.9	4.7	6.2	15.5	5.3	14.8	28	7000	5220	
KU1R 132 SX2	KUOR 112 M2	7.5	11.6	24.8	7.5	11.3	24.8	7.5	11	24.8	6.6	9.3	21.8	5.9	22.4	43	7000	5220
KU1R 160 M2	KUOR 132 M2	10.5	15.6	35	10.5	15.6	35	10	14.6	33	8.4	12.2	28	6	37.6	76	6000	5220
KU1R 160 MX2	KUOR 160 S2	15	21.6	48.9	14.9	21.6	49	15	21.6	49.4	13.5	19.4	44.5	7.6	48.8	99	6000	5220
KU1R 160 L2	KUOR 160 M2	18.5	25.6	61	18.5	25.6	60.9	18.5	25.6	60.9	16.4	22.7	54	7.6	51.2	110	6000	5220
KU1R 180 M2	KUOR 180 S2	22	30	72	22	30	71.9	22	30	72.1	20.9	28.5	68.5	8.8	60	130	6000	5220
KU1R 200 L2	KUOR 180 M2	30	40.4	97	30	40.4	98	30	40.4	97.8	28.2	38	92	10.8	87.2	190	5000	5000
KU1R 200 LX2	KUOR 200 M2	37	51.2	120	37	51.2	120	37	51.2	120	35.4	49.2	115	14.5	94.4	200	5000	5000
KU1R 225 M2	KUOR 200 L2	45	60.8	146	45	60.8	146	45	60.8	146	42.2	57.2	137	18	124	270	5000	5000
KU1R 250 M2	KUOR 225 M2	55	74.4	178	55	74.4	178	55	74.4	178	51	69.2	165	23	148	320	4500	4500
KU1R 280 S2	KUOR 250 S2	74	98	238	74	98	238	74	98	238	69.5	92	224	30	195	430	4300	4300
KU1R 280 M2	KUOR 250 M2	87	117	280	87	117	280	87	117	280	80.7	108	260	36	258	560	4300	4300
KU1R 315 S2	KUOR 280 S2	110	146	353	110	146	354	110	146	354	110	146	354	36.5	278	610	3800	3800
KU1R 315 M2	KUOR 280 M2	132	175	424	132	175	424	132	175	424	132	175	424	40	364	800	3800	3800
KU1R 315 MX2	KUOR 315 S2	160	207	514	160	207	514	160	207	514	160	207	514	40	413	930	3600	3600
KU1R 315 MY2	KUOR 315 M2	192	251	616	192	251	616	192	251	616	192	251	616	65	524	1170	3600	3600
KU1R 315 L2	KUOR 315 L2	220	285	706	220	285	706	220	285	706	220	285	706	67	496	1120	3600	3600
KU1R 315 LX2	KUOR 315 LX2	270	350	867	270	350	867	270	350	867	270	350	867	50	627	1410	3600	3600
KU2R 355 MY2		315	427	1007	315	427	1007	315	427	1007	297	402	950		986	2110	3600	3600
KU2R 355 M2		330	434	1058	330	434	1057	330	434	1057	306	402	980		826	1830	3600	3600
KU2R 355 MX2		355	470	1138	355	470	1138	355	470	1138	355	470	1138		1304	2860	3600	3600
KU2R 355 LY2		380	496	1215	370	480	1186	370	480	1186	370	480	1186		1078	2420	3600	3600
KU2R 355 L2		425	560	1360	370	480	1186	370	480	1186	370	480	1186		1292	2910	3600	3600

Three-phase motors with squirrel-cage rotor
Special insulation for converter-fed operation without filter up to 500 V

with surface cooling, duty type S8, S9
 for rated voltage, thermal class 155 (F), degree of protection IP 55, 50 Hz

Motor selection data, mains-fed operation												Design point 500 V, 50 Hz	
Type IEC/DIN	Type Progressive	P _B	M _B	n _B	η _B (IEC/EN 60034-2)	cosφ _B	I _B 500 V	I _A /I _B	M _A /M _B	M _S /M _B	M _R /M _B	J	m
		kW	Nm	rpm	%	-	A	-	-	-	-	kgm ²	kg
Synchronous speed 1500 rpm – 4-pole version													
KU10 56 K4		0.06	0.41	1410	60.1	0.6	0.19	3.1	2.3	2.3	2.7	0.00019	4.3
KU1R 56 G4		0.09	0.63	1375	61.6	0.68	0.25	3.2	1.9	1.9	2.2	0.00019	4.4
KU1R 63 K4	KUOR 56 K4	0.12	0.84	1370	57.9	0.68	0.35	3.2	1.9	1.8	2.2	0.00019	4.8
KU1R 63 G4	KUOR 56 G4	0.18	1.26	1360	60.6	0.66	0.52	3.3	2	2	2.3	0.00024	5.2
KU1R 71 K4	KUOR 63 K4	0.25	1.72	1385	64.3	0.72	0.62	3.6	1.8	1.8	2.1	0.0004	6.8
KU1R 71 G4	KUOR 63 G4	0.37	2.58	1370	68.1	0.74	0.85	3.8	2	2	2.2	0.0005	7.8
KU1R 80 K4	KUOR 71 K4	0.55	3.75	1400	71.9	0.69	1.3	4.1	2.1	2	2.3	0.00087	10.6
KU1R 80 G4	KUOR 71 G4	0.75	5.12	1400	73.6	0.7	1.7	4.6	2.2	2.1	2.3	0.00107	11.7
KU1R 90 S4	KUOR 80 K4	1.1	7.5	1410	76.7	0.79	2.1	5.5	2.3	2.2	2.5	0.00207	15.5
KU1R 90 L4	KUOR 80 G4	1.5	10.2	1400	78.6	0.81	2.7	5.5	2.5	2.4	2.6	0.0026	18
KU1R 100 L4	KUOR 90 L4	2.2	14.9	1410	81.2	0.79	4	6	2.5	2.3	2.7	0.004	23.5
KU1R 100 LX4	KUOR 100 S4	3	20	1430	82.4	0.79	5.3	6.5	2.5	2.2	2.9	0.00725	30
KU1R 112 M4	KUOR 100 L4	4	26.6	1435	84.1	0.78	7	6.9	2.6	2.5	3.2	0.009	37
KU1R 112 MX4	KUOR 100 LX4	5.5	36.9	1425	86.3	0.78	9.4	6.3	2.5	2.4	2.9	0.011	45
KU1R 132 S4T	KUOR 100 LX4	5.5	36.9	1425	86.3	0.78	9.4	6.3	2.5	2.4	2.9	0.011	47
KU1R 132 S4	KUOR 112 M4	5.5	36.5	1440	85.7	0.89	8.4	6.5	1.9	1.7	3	0.015	50
KU1R 132 M4	KUOR 132 S4	7.5	49.4	1450	87	0.84	12	6	2	1.7	2.9	0.028	70
KU1R 160 M4	KUOR 132 M4	11	72	1450	88.4	0.85	16.8	6.8	2.2	1.9	3.3	0.035	92
KU1R 160 L4	KUOR 160 S4	15	98	1465	89.4	0.86	22.4	7.3	2.5	2	3	0.078	120
KU1R 180 M4	KUOR 160 M4	18.5	121	1460	90	0.86	27.6	6.8	2.5	2	2.9	0.09	136
KU1R 180 L4	KUOR 180 S4	22	143	1465	90.5	0.84	33.6	6.5	2	1.8	2.6	0.138	170
KU1R 200 L4	KUOR 180 M4	30	196	1465	91.5	0.85	44.4	7	2	1.7	2.4	0.168	200
KU1R 225 S4	KUOR 200 M4	37	240	1470	92.5	0.86	53.6	7	2	1.7	2.5	0.275	270
KU1R 225 M4	KUOR 200 L4	45	292	1470	93	0.86	64.8	7	2	1.7	2.5	0.313	300
KU1R 250 M4	KUOR 225 M4	55	356	1475	93.5	0.86	78.8	7	2.2	1.7	2.3	0.525	375
KU1R 280 S4	KUOR 250 S4	75	484	1480	94.1	0.86	107	7	2	1.7	2.2	0.95	520
KU1R 280 M4	KUOR 250 M4	90	581	1480	94.6	0.86	128	7	2.1	1.6	2.2	1.1	580
KU1R 315 S4	KUOR 280 S4	110	707	1485	95.1	0.86	155	7.5	1.8	1.6	2.2	1.96	740
KU1R 315 M4	KUOR 280 M4	132	849	1485	95.1	0.86	186	7	1.8	1.5	2.2	2.27	840
KU1R 315 MX4	KUOR 315 S4	160	1032	1480	95	0.87	223	7	1.8	1.5	2	2.73	1000
KU1R 315 MY4	KUOR 315 M4	200	1286	1485	96	0.88	274	7.5	2	1.8	2.4	4.82	1200
KU1R 315 L4	KUOR 315 L4	250	1608	1485	96.1	0.9	334	8	2	1.6	2.3	5.93	1510
KU1R 315 LX4	KUOR 315 LX4	315	2019	1490	96.5	0.88	428	8.6	1.9	1.5	2.5	6.82	1630
KU2R 355 MY4		315	2016	1492	95.6	0.85	448	7.1	1.4	1	2.9	5.6	1950
KU2R 355 M4		355	2275	1490	96.8	0.84	504	8.1	1.8	1	3.1	7.9	2150
KU2R 355 MX4		400	2557	1494	96.8	0.84	568	8.6	1.3	1	3	9.5	2400
KU2R 355 LY4		450	2884	1490	96.8	0.82	654	8	1.2	1	3	10	2500
KU2R 355 L4		500	3205	1490	96.7	0.79	756	7.9	1.1	1	3	10	2500

Motor selection data, converter-fed operation														Converter-fed operation 500 V				
Type IEC/DIN	Type Progressive	Converter input, 50 Hz			Setting range 1 : 2.5			Setting range 1 : 5			Setting range 1 : 10			I ₀	I _{max}	M _{max}	n _{max}	n _{maxFU}
		P _{50 Hz}	i _B	M _B	P _{1:2.5}	i _B	M _B	P _{1:5}	i _B	M _B	P _{1:10}	i _B	M _B					
		500 V			500 V			500 V			500 V							
		kW	A	Nm	kW	A	Nm	kW	A	Nm	kW	A	Nm	kW	A	Nm	rpm	rpm
Synchronous speed 1500 rpm – 4-pole version																		
KU10 56 K4		0.06														0.8	12000	2610
KU1R 56 G4		0.09														1	12000	2610
KU1R 63 K4	KUOR 56 K4	0.12		0.84	0.1		0.66	0.06		0.41	0.05		0.32			1.4	12000	2610
KU1R 63 G4	KUOR 56 G4	0.18		1.27	0.14		1.01	0.09		0.62	0.07		0.49			2.2	12000	2610
KU1R 71 K4	KUOR 63 K4	0.25		1.76	0.19		1.38	0.13		0.91	0.1		0.67			2.7	11000	2610
KU1R 71 G4	KUOR 63 G4	0.37		2.62	0.29		2.1	0.19		1.36	0.14		1.01			4.3	11000	2610
KU1R 80 K4	KUOR 71 K4	0.55		3.7	0.44		3	0.35		2.4	0.2		1.36			6.6	11000	2610
KU1R 80 G4	KUOR 71 G4	0.75		5.1	0.6		4.1	0.49		3.3	0.27		1.88			9	11000	2610
KU1R 90 S4	KUOR 80 K4	1.1		7.5	0.88		5.9	0.7		4.7	0.44		3			14	9000	2610
KU1R 90 L4	KUOR 80 G4	1.5		10.2	1.2		8	0.94		6.4	0.6		4.1			20	9000	2610
KU1R 100 L4	KUOR 90 L4	2.2		14.9	1.76		11.9	1.39		9.4	1		6.8			30	8000	2610
KU1R 100 LX4	KUOR 100 S4	3		19.8	2.4		15.8	2.2		14.4	1.68		11.3			44	6000	2610
KU1R 112 M4	KUOR 100 L4	4		26.6	3.2		21.3	3		19.4	2.3		15.3			65	6000	2610
KU1R 112 MX4	KUOR 100 LX4	5.5		36.90	5.2		35.1	4.4		29.6	3.4		22.7			82	6000	2610
KU1R 132 S4T	KUOR 100 LX4	5.5		36.90	4.2		28.1	3.5		23.7	2.7		18.2			82	6000	2610
KU1R 132 S4	KUOR 112 M4	5.5	8.4	36.5	5.5	8.4	36.5	5.5	7.4	36.5	5.1	6.7	34	5.1	20	76	3600	2610
KU1R 132 M4	KUOR 132 S4	7.5	12	49.4	7.5	12	49.4	6.6	10.4	43.5	6.3	10.1	41.5	7	27.2	100	3600	2610
KU1R 160 M4	KUOR 132 M4	11	16.8	72	11	16.8	72.7	9.4	14.4	62	8.3	12.7	55	9.8	41.6	160	3600	2610
KU1R 160 L4	KUOR 160 S4	15	22.4	98	15	22.4	98.5	14.2	21.2	93	12.7	19	83.5	12	50.4	200	3600	2610
KU1R 180 M4	KUOR 160 M4	18	26.8	118	18	26.8	118	16	23.8	105	14.5	21.6	95	14	60.8	240	3000	2610
KU1R 180 L4	KUOR 180 S4	22	33.6	143	22	33.6	144	20	30.6	130	17	26	113	20	67.2	260	3000	2610
KU1R 200 L4	KUOR 180 M4	29	42.9	190	29	43.2	190	26	38.5	170	23	34.1	150	20	80	320	3000	2610
KU1R 225 S4	KUOR 200 M4	37	53.6	240	37	53.6	240	36	52.2	231	32	46.4	209	23	103.2	420	3000	2610
KU1R 225 M4	KUOR 200 L4	45	64.8	292	45	64.8	293	43	61.9	278	38	54.7	248	27	124.8	510	3000	2610
KU1R 250 M4	KUOR 225 M4	55	78.8	356	55	78.8	357	52	74.5	340	47	67.6	305	28	139.2	570	3000	2610
KU1R 280 S4	KUOR 250 S4	75	107	484	75	107	486	74	106	476	67	96	432	30	181	740	3000	2610
KU1R 280 M4	KUOR 250 M4	90	128	581	90	128	583	88	126	570	80	114	520	43	216	890	3000	2610
KU1R 315 S4	KUOR 280 S4	110	155	707	110	155	710	110	155	710	110	155	710	53	261	1080	3000	2610
KU1R 315 M4	KUOR 280 M4	132	186	849	132	186	852	132	186	852	132	186	852	59	314	1300	3000	2610
KU1R 315 MX4	KUOR 315 S4	160	223	1032	160	223	1029	160	223	1029	145	202	930	67	343	1440	3000	2610
KU1R 315 MY4	KUOR 315 M4	200	274	1286	200	274	1286	200	274	1286	192	262	1235	79	506	2160	3000	2610
KU1R 315 L4	KUOR 315 L4	250	334	1608	250	334	1608	250	334	1608	239	319	1540	100	590	2580	3000	2610
KU1R 315 LX4	KUOR 315 LX4	285	387	1833	277	376	1780	277	376	1780	264	358	1700	130	823	3530	3000	2610
KU2R 355 MY4		315	448	2016	315	448	2018	315	448	2018	293	417	1879		1000	4090	3000	2610
KU2R 355 M4		355	504	2275	355	504	2275	355	504	2275	328	466	2100		1202	4930	3000	2610
KU2R 355 MX4		390	554	2500	390	554	2500	390	554	2500	368	522	2358		1310	5360	3000	2610
KU2R 355 LY4		430	626	2756	430	626	2755	413	626	2650	390	567	2500		1510	6050	3000	2610
KU2R 355 L4		410	620	2628	410	620	2628	394	620	2528	390	590	2500		1744	6720	3000	2610

Three-phase motors with squirrel-cage rotor
Special insulation for converter-fed operation without filter up to 500 V

with surface cooling, duty type S8, S9
 for rated voltage, thermal class 155 (F), degree of protection IP 55, 50 Hz

Motor selection data, mains-fed operation												Design point 500 V, 50 Hz	
Type IEC/DIN	Type Progressive	P _B	M _B	n _B	η _B (IEC/EN 60034-2)	cosφ _B	I _B 500 V	I _M /I _B	M _A /M _B	M _S /M _B	M _R /M _B	J	m
		kW	Nm	rpm	%	-	A	-	-	-	-	kgm ²	kg
Synchronous speed 1000 rpm – 6-pole version													
KU1R 63 K6	KUOR 56 K6	0.09	0.96	895	50.5	0.56	0.37	2.5	2	2	2.4	0.00024	4.9
KU1R 63 G6	KUOR 56 G6	0.12	1.3	880	52	0.56	0.47	2.5	2	2	2.3	0.00027	5.7
KU1R 71 K6	KUOR 63 K6	0.18	1.86	925	58	0.51	0.7	2.8	1.6	1.6	2.1	0.00045	7.4
KU1R 71 G6	KUOR 63 G6	0.25	2.61	915	60	0.55	0.88	2.9	2	2	2.21	0.0006	8.3
KU1R 80 K6	KUOR 71 K6	0.37	3.86	915	66	0.66	0.98	3.4	2	2	2	0.0013	11
KU1R 80 G6	KUOR 71 G6	0.55	5.7	915	68	0.67	1.38	3.7	2.2	2.2	2.4	0.00175	12.5
KU1R 90 S6	KUOR 80 K6	0.75	7.7	935	70	0.64	1.94	4.5	2.4	2.4	2.6	0.00325	16
KU1R 90 L6	KUOR 80 G6	1.1	11.2	935	73	0.69	2.52	4.6	2.2	2.2	2.6	0.00425	19
KU1R 100 L6	KUOR 90 L6	1.5	15.2	945	76.4	0.73	3.12	4.6	2.1	2	2.4	0.00625	24
KU1R 112 M6	KUOR 100 L6	2.2	22.1	950	79.8	0.74	4.28	5.3	2.2	2.1	2.7	0.01225	33.5
KU1R 132 S6T	KUOR 100 LX6	3	30.6	935	81.9	0.75	5.64	5.2	2.5	2.5	2.9	0.0139	39
KU1R 132 S6	KUOR 112 M6	3	30	955	78.5	0.82	5.4	5.7	1.8	1.6	2.7	0.018	46
KU1R 132 M6	KUOR 112 MX6	4	40	955	80	0.8	7.2	6	2.2	2	3.1	0.023	53
KU1R 132 MX6	KUOR 132 S6	5.5	55	955	83	0.83	9.2	5	1.8	1.5	2.3	0.043	70
KU1R 160 M6	KUOR 132 M6	7.5	75	960	85	0.82	12.4	5.5	2	1.6	2.5	0.053	86
KU1R 160 L6	KUOR 160 S6	11	109	965	85.2	0.86	17.2	5	2	1.7	2.3	0.113	114
KU1R 180 L6	KUOR 160 M6	15	148	965	86	0.83	24.4	6	2.4	2.1	2.7	0.145	136
KU1R 200 L6	KUOR 180 S6	18.5	182	970	88.1	0.87	28	5.5	2	1.7	2.4	0.228	175
KU1R 200 LX6	KUOR 180 M6	22	217	970	88.8	0.87	32.8	6.2	2.2	1.8	2.6	0.268	200
KU1R 225 M6	KUOR 200 M6	30	294	973	90.4	0.89	43.2	6.5	2.2	1.7	2.5	0.443	265
KU1R 250 M6	KUOR 225 M6	37	362	975	91	0.89	52.8	6.5	2.2	1.7	2.3	0.825	360
KU1R 280 S6	KUOR 250 S6	45	439	980	92	0.87	64.8	6	2	1.5	2	1.28	465
KU1R 280 M6	KUOR 250 M6	55	536	980	92.5	0.88	78	6.5	2.3	1.7	2.4	1.48	520
KU1R 315 S6	KUOR 280 S6	75	727	985	93.7	0.87	106	7	2	1.6	2.4	2.63	690
KU1R 315 M6	KUOR 280 M6	90	868	990	94.4	0.88	125	7	2	1.7	2.4	3.33	800
KU1R 315 MX6	KUOR 315 S6	110	1061	990	94	0.88	154	7.5	2.2	1.7	2.6	3.6	880
KU1R 315 MY6	KUOR 315 M6	132	1273	990	95	0.88	182	7.5	2	1.7	2.4	6	1050
KU1R 315 L6	KUOR 315 L6	160	1551	985	95.3	0.89	218	7.5	2.3	1.9	2.4	6.67	1250
KU1R 315 LX6	KUOR 315 LX6	200	1929	990	95	0.87	279	8.3	2.2	2	2.7	8.6	1460
KU2R 355 MY6		200	1920	995	96.1	0.83	290	7	1.5	1.3	2.4	8.1	1550
KU2R 355 M6		250	2402	994	96	0.81	371	7	1.8	1.3	2.3	8.2	1650
KU2R 355 MX6		315	3023	995	96.5	0.83	454	6.8	1.6	1.3	2.5	12.1	2200
KU2R 355 LY6		355	3407	995	96	0.78	547	7.4	1.9	1.4	2.6	14	2400

Motor selection data, converter-fed operation													Converter-fed operation 500 V					
Type IEC/DIN	Type Progressive	Converter input, 50 Hz			Setting range 1 : 2.5			Setting range 1 : 5			Setting range 1 : 10			I ₀	I _{max}	M _{max}	n _{max}	n _{maxFU}
		P _{50 Hz}	i _B	M _B	P _{1:2.5}	i _B	M _B	P _{1:5}	i _B	M _B	P _{1:10}	i _B	M _B					
		500 V			500 V			500 V			500 V			500 V				
		kW	A	Nm	kW	A	Nm	kW	A	Nm	kW	A	Nm	kW	A	Nm	rpm	rpm
Synchronous speed 1000 rpm – 6-pole version																		
KU1R 63 K6	KUOR 56 K6	0.09		0.98	0.06		0.7	0.06		0.57	0.04		0.45			1.7	12000	1740
KU1R 63 G6	KUOR 56 G6	0.12		1.31	0.09		0.94	0.07		0.77	0.06		0.61			2.3	12000	1740
KU1R 71 K6	KUOR 63 K6	0.16		1.66	0.12		1.28	0.08		0.85	0.06		0.6			3	11000	1740
KU1R 71 G6	KUOR 63 G6	0.22		2.3	0.17		1.78	0.11		1.19	0.08		0.84			4.4	11000	1740
KU1R 80 K6	KUOR 71 K6	0.37		3.9	0.28		2.9	0.18		1.94	0.14		1.5			5.9	10000	1740
KU1R 80 G6	KUOR 71 G6	0.55		5.8	0.42		4.4	0.27		2.9	0.22		2.3			10	10000	1740
KU1R 90 S6	KUOR 80 K6	0.75		7.6	0.52		5.3	0.4		4.1	0.31		3.2			15	9000	1740
KU1R 90 L6	KUOR 80 G6	1.1		11.3	0.72		7.8	0.59		6.1	0.46		4.7			22	9000	1740
KU1R 100 L6	KUOR 90 L6	1.5		15.3	1.2		12.2	0.96		10	0.76		7.7			27	8000	1740
KU1R 112 M6	KUOR 100 L6	2.2		22.3	1.76		17.9	1.44		14.8	1.12		11.5			45	6000	1740
KU1R 132 S6T	KUOR 100 LX6	3		30.8	2.4		24.6	2		20.2	1.6		16.3			68	6000	1740
KU1R 132 S6	KUOR 112 M6	3	5.4	30.8	3	5.4	30.8	3	5	30.8	3	3.8	30.8	4.3	11	56	2400	1740
KU1R 132 M6	KUOR 112 MX6	4	7.2	40.6	4	7.2	40.6	4	6.6	40.6	4	5	40.6	5.9	17.6	86	2400	1740
KU1R 132 MX6	KUOR 132 S6	5.5	9.2	55	5.5	9.2	55.9	5.1	8.6	51.4	4.3	7.2	44	5.9	16.8	88	2400	1740
KU1R 160 M6	KUOR 132 M6	7.5	12.4	75	7.5	12.4	75.8	6.9	11.4	70	5.9	9.8	60	8.5	24	130	2400	1740
KU1R 160 L6	KUOR 160 S6	11	17.2	109	11	17.2	111	10	15.6	101	9.4	14.7	94	9.5	29.6	170	2400	1740
KU1R 180 L6	KUOR 160 M6	15	24.4	148	15	24.4	148	13.6	22.2	135	12.6	20.5	125	17	51.2	280	2000	1740
KU1R 200 L6	KUOR 180 S6	18.5	28	182	18	27.2	183	17	26	169	16	24.4	157	13.5	51.2	300	2000	1740
KU1R 200 LX6	KUOR 180 M6	22	32.8	217	22	32.8	218	20	30	200	19	28.4	188	16	65.6	390	2000	1740
KU1R 225 M6	KUOR 200 M6	30	43.2	294	30	43.2	295	30	43.2	295	29	42	286	18	82.4	510	2000	1740
KU1R 250 M6	KUOR 225 M6	37	52.8	362	37	52.8	362	37	52.8	362	36	51.6	350	24	93.6	580	2000	1740
KU1R 280 S6	KUOR 250 S6	45	64.8	439	45	64.8	441	45	64.8	441	45	64.8	441	24.5	99.2	610	2000	1740
KU1R 280 M6	KUOR 250 M6	55	78	536	55	78	539	55	78	539	55	78	539	32	144.8	900	2000	1740
KU1R 315 S6	KUOR 280 S6	75	106	727	75	106	731	75	106	731	75	106	731	42	197	1220	2000	1740
KU1R 315 M6	KUOR 280 M6	90	125	868	90	125	873	90	125	873	90	125	873	47.5	230	1450	2000	1740
KU1R 315 MX6	KUOR 315 S6	110	154	1061	110	154	1066	107	150	1040	100	140	970	62	308	1930	2000	1740
KU1R 315 MY6	KUOR 315 M6	132	182	1273	132	182	1280	132	182	1280	132	182	1280	66.5	336	2130	2000	1740
KU1R 315 L6	KUOR 315 L6	160	218	1551	160	218	1551	160	218	1551	160	218	1551	80	402	2600	2000	1740
KU1R 315 LX6	KUOR 315 LX6	185	258	1794	185	258	1794	185	258	1794	175	244	1700	115	580	3640	2000	1740
KU2R 355 MY6		200	290	1920	200	290	1929	200	290	1929	185	268	1780		534	3220	2000	1740
KU2R 355 M6		250	371	2402	250	371	2412	250	371	2412	238	354	2300		657	3860	2000	1740
KU2R 355 MX6		300	433	2894	300	433	2894	300	433	2894	298	430	2870		875	5290	2000	1740
KU2R 355 LY6		315	486	3023	315	486	3023	315	486	3023	315	486	3023		1096	6200	2000	1740

Three-phase motors with squirrel-cage rotor
Special insulation for converter-fed operation without filter up to 500 V

with surface cooling, duty type S8, S9
 for rated voltage, thermal class 155 (F), degree of protection IP 55, 50 Hz

Motor selection data, mains-fed operation												Design point 500 V, 50 Hz	
Type IEC/DIN	Type Progressive	P _B	M _B	n _B	η _B (IEC/EN 60034-2)	cosφ _B	I _B 500 V	I _M /I _B	M _A /M _B	M _S /M _B	M _R /M _B	J	m
		kW	Nm	rpm	%	-	A	-	-	-	-	kgm ²	kg
Synchronous speed 750 rpm – 8-pole version													
KU1R 71 K8	KUOR 63 K8	0.09	1.27	675	45.5	0.51	0.45	2.1	1.9	1.9	2.1	0.0005	6.6
KU1R 71 G8	KUOR 63 G8	0.12	1.71	670	46.5	0.51	0.58	2.3	1.8	1.8	2.1	0.0006	8.1
KU1R 80 K8	KUOR 71 K8	0.18	2.49	690	56.5	0.59	0.62	2.8	2	2	2.2	0.0013	10.5
KU1R 80 G8	KUOR 71 G8	0.25	3.44	695	58	0.56	0.9	3	2.3	2.3	2.5	0.00175	12
KU1R 90 S8	KUOR 80 K8	0.37	5	700	61.5	0.54	1.28	3	1.9	1.9	2.1	0.003	15
KU1R 90 L8	KUOR 80 G8	0.55	7.6	695	64.5	0.6	1.63	3.2	1.9	1.9	2.2	0.00375	18
KU1R 100 L8	KUOR 90 L8	0.75	10.2	705	63	0.6	2.32	3.3	1.8	1.8	2.2	0.00625	23
KU1R 100 LX8	KUOR 100 S8	1.1	14.9	705	73	0.67	2.6	4	2	2	2.4	0.009	28
KU1R 112 M8	KUOR 100 L8	1.5	20.3	705	75.5	0.7	3.3	4.4	2.2	2.1	2.5	0.01225	33.5
KU1R 132 S8T	KUOR 100 LX8	2.2	30.7	685	74.1	0.68	5	3.8	2	1.9	2.3	0.0139	39
KU1R 132 S8	KUOR 112 M8	2.2	29.8	705	75.5	0.76	4.4	4.5	1.7	1.6	2.3	0.018	46
KU1R 132 M8	KUOR 112 MX8	3	40.6	705	78	0.75	5.9	4.5	1.7	1.6	2.3	0.023	53
KU1R 160 M8	KUOR 132 S8	4	53.8	710	79.3	0.78	7.4	4	1.6	1.3	1.9	0.043	70
KU1R 160 MX8	KUOR 132 M8	5.5	74	710	81.4	0.78	10	4.5	1.7	1.6	2.1	0.053	86
KU1R 160 L8	KUOR 160 S8	7.5	99	725	83	0.78	13.2	4.5	1.8	1.6	2.1	0.113	114
KU1R 180 L8	KUOR 160 M8	11	146	720	85	0.78	19.2	4.5	2	1.7	2.1	0.145	136
KU1R 200 L8	KUOR 180 S8	15	198	725	86.5	0.79	25.2	5	2	1.7	2.3	0.228	175
	KUOR 180 M8	18.5	244	725	87.5	0.8	30.4	5	1.9	1.7	2.2	0.268	200
KU1R 225 S8		18.5	244	725	89.2	0.83	28.8	5.5	2	1.6	2.2	0.44	265
KU1R 225 M8	KUOR 200 M8	22	290	725	89.2	0.84	34	5	1.8	1.5	2.2	0.44	265
KU1R 250 M8	KUOR 225 M8	30	392	730	90.2	0.79	48.8	5.5	2.2	1.8	2.2	0.825	360
KU1R 280 S8	KUOR 250 S8	37	481	735	91	0.8	58.8	5.5	2	1.5	2	1.35	465
KU1R 280 M8	KUOR 250 M8	45	585	735	91.5	0.77	73.6	6	2.3	1.8	2.4	1.55	520
KU1R 315 S8	KUOR 280 S8	55	710	740	93.1	0.8	85.6	6.5	1.8	1.6	2.3	2.63	690
KU1R 315 M8	KUOR 280 M8	75	968	740	93.3	0.81	114	6	2	1.6	2.3	3.33	800
KU1R 315 MX8	KUOR 315 S8	90	1161	740	93.5	0.81	138	6	1.9	1.6	2.2	3.6	880
KU1R 315 MY8	KUOR 315 M8	110	1420	740	94.6	0.81	166	6.5	2.1	1.8	2.4	6	1100
KU1R 315 L8	KUOR 315 L8	132	1704	740	95	0.83	194	6.3	2	1.7	2.1	6.76	1250
KU1R 315 LX8	KUOR 315 LX8	160	2065	740	95.2	0.79	246	7.2	2.2	1.9	2.5	8.71	1430
KU2R 355 MY8		160	2054	744	95.2	0.8	242	6.8	1.3	1	2.5	9.3	1500
KU2R 355 M8		200	2571	743	95.6	0.77	314	6.5	1.6	1	2.7	9.5	1600
KU2R 355 MX8		250	3209	744	95.8	0.78	386	6.6	1.3	1	2.8	13.4	2200
KU2R 355 LY8		280	3594	744	95.3	0.78	435	8.2	1.2	1	2.8	15.8	2400

Motor selection data, converter-fed operation													Converter-fed operation 500 V					
Type IEC/DIN	Type Progressive	Converter input, 50 Hz			Setting range 1 : 2.5			Setting range 1 : 5			Setting range 1 : 10			I ₀	I _{max}	M _{max}	n _{max}	n _{maxFU}
		P _{50 Hz}	i _B	M _B	P _{1:2.5}	i _B	M _B	P _{1:5}	i _B	M _B	P _{1:10}	i _B	M _B					
		500 V			500 V			500 V			500 V							
		kW	A	Nm	kW	A	Nm	kW	A	Nm	kW	A	Nm	kW	A	Nm	rpm	rpm
Synchronous speed 750 rpm – 8-pole version																		
KU1R 71 K8	KUOR 63 K8	0.09		1.31	0.06		0.89	0.03		0.52	0.02		0.32			2	11000	1305
KU1R 71 G8	KUOR 63 G8	0.12		1.76	0.08		1.21	0.05		0.7	0.03		0.43			2.7	11000	1305
KU1R 80 K8	KUOR 71 K8	0.18		2.47	0.14		1.92	0.12		1.68	0.09		1.16			4.2	10000	1305
KU1R 80 G8	KUOR 71 G8	0.25		3.46	0.2		2.7	0.18		2.5	0.12		1.66			6.6	10000	1305
KU1R 90 S8	KUOR 80 K8	0.37		5	0.29		3.9	0.19		2.6	0.15		2.1			8.1	9000	1305
KU1R 90 L8	KUOR 80 G8	0.55		7.6	0.43		6	0.3		4.1	0.23		3.2			12	9000	1305
KU1R 100 L8	KUOR 90 L8	0.75		10.3	0.56		7.7	0.39		5.4	0.29		4			17	8000	1305
KU1R 100 LX8	KUOR 100 S8	1.1		15.3	0.88		12.2	0.69		9.6	0.48		6.7			27	6000	1305
KU1R 112 M8	KUOR 100 L8	1.5		20.8	1.2		16.6	0.96		13.2	0.66		9.2			39	6000	1305
KU1R 132 S8T	KUOR 100 LX8	2.1		29.5	1.28		18.2	1.04		15	0.84		11.8			54	6000	1305
KU1R 132 S8	KUOR 112 M8	2.2	4.4	30	2.2	4.4	30	2.2	3.8	30	2.09	3.3	28.5	4	7.7	47	1800	1305
KU1R 132 M8	KUOR 112 MX8	3	5.9	40.9	3	5.9	40.9	3	5.1	40.9	2.85	4.3	38.8	5.1	10.5	65	1800	1305
KU1R 160 M8	KUOR 132 S8	4	7.4	53.8	4	7.4	54.6	3.6	6.7	48.6	3.2	5.9	43.7	5	10.8	71	1800	1305
KU1R 160 MX8	KUOR 132 M8	5.5	10	74	5.5	10	75	4.9	8.9	67	4.4	8	60	8	14.9	100	1800	1305
KU1R 160 L8	KUOR 160 S8	7.5	13.2	99	7.5	13.2	102	6.6	11.6	89.8	6.2	10.9	83.6	10	20.8	140	1800	1305
KU1R 180 L8	KUOR 160 M8	11	19.2	146	11	19.2	147	9.7	17	130	9	15.7	120	14	30.4	210	1500	1305
KU1R 200 L8	KUOR 180 S8	15	25.2	198	14	23.5	184	12.6	21.2	168	11.4	19.1	152	18	44	310	1500	1305
	KUOR 180 M8	18.5	30.4	244	17	28	225	15.3	25.1	205	13.9	22.9	185	18	51.2	370	1500	1305
KU1R 225 S8		18.5	28.8	244	17	26.5	225	15.6	24.3	205	14	21.8	185	16	48.8	370	1500	1305
KU1R 225 M8	KUOR 200 M8	22	34	290	20	30.9	264	18.3	28.3	241	16.5	25.5	217	20	56.8	440	1500	1305
KU1R 250 M8	KUOR 225 M8	30	48.8	392	30	48.8	392	29	47.2	380	26	42.3	345	31	82.4	600	1500	1305
KU1R 280 S8	KUOR 250 S8	37	58.8	481	37	58.8	481	37	58.8	481	37	58.8	481	35	90.4	670	1500	1305
KU1R 280 M8	KUOR 250 M8	45	73.6	585	45	73.6	585	45	73.6	585	45	73.6	585	44	136	980	1500	1305
KU1R 315 S8	KUOR 280 S8	55	85.6	710	55	85.6	710	55	85.6	710	55	85.6	710	46	152	1140	1500	1305
KU1R 315 M8	KUOR 280 M8	75	114	968	75	114	968	75	114	968	75	114	968	62	202	1550	1500	1305
KU1R 315 MX8	KUOR 315 S8	90	138	1161	90	138	1169	90	138	1169	85	130	1100	81	232	1780	1500	1305
KU1R 315 MY8	KUOR 315 M8	110	166	1420	110	166	1429	110	166	1429	106	159	1373	86	306	2380	1500	1305
KU1R 315 L8	KUOR 315 L8	132	194	1704	132	194	1715	132	194	1715	127	186	1650	90	313	2500	1500	1305
KU1R 315 LX8	KUOR 315 LX8	145	222	1871	145	222	1871	145	222	1871	145	222	1871	140	473	3610	1500	1305
KU2R 355 MY8		160	242	2054	160	242	2051	160	242	2051	153	232	1960		466	3590	1500	1305
KU2R 355 M8		200	314	2571	200	314	2564	200	314	2564	184	289	2360		651	4850	1500	1305
KU2R 355 MX8		225	348	2884	225	348	2884	225	348	2884	225	348	2884		832	6280	1500	1305
KU2R 355 LY8		230	358	2948	230	358	2948	230	358	2948	230	358	2948		938	7040	1500	1305

Three-phase motors with squirrel-cage rotor
Special insulation for converter-fed operation without filter up to 690 V

with surface cooling, duty type S8, S9
 for rated voltage, thermal class 155 (F), degree of protection IP 55, 50 Hz

Motor selection data													Design point 690 V, 50 Hz				
Type IEC/DIN	Type Progressive	P _B	M _B	M _{max}	n	η _B	cosφ _B	I _B	I _{max}	I _A /I _B	M _K /M _B	Setting range 1:5, 1:10 P _{1:5, 1:10} M _{1:5, 1:10} I _{1:5, 1:10}			M _K /M _B	J	m
		kW	Nm	Nm	rpm	%	-	A	A	-	-	kW	Nm	A	rpm	kgm ²	kg
Synchronous speed 3000 rpm – 2-pole version																	
KV1R 132 S2	KVOR 112 MY2	4.0	13	21.0	2860	85.5	0.86	4.6	8.1	5.5	2.2	3.0	10.0	3.5	5220	0.0081	52
KV1R 132 SX2	KVOR 112 M2	5.5	18	32.0	2900	87.0	0.86	5.8	11.3	6.6	2.5	4.1	13.6	4.7	5220	0.0110	57
KV1R 160 M2	KVOR 132 M2	7.5	25	52.0	2900	88.5	0.90	7.8	18.6	7.0	3.0	6.0	19.8	6.3	5220	0.0258	81
KV1R 160 MX2	KVOR 160 S2	11.0	36	73.0	2930	89.0	0.90	11.6	26.1	7.1	2.9	8.8	28.7	9.2	5220	0.0575	118
KV1R 160 L2	KVOR 160 M2	15.0	49	96.0	2920	90.5	0.92	15.1	32.5	7.2	2.8	12.0	39.2	12.0	5220	0.0675	134
-	KVOR 160 MX2	18.5	60	122.0	2945	89.2	0.90	19.7	44.6	8.1	2.9	14.8	48.0	15.6	5220	0.0782	142
KV1R 180 M2	KVOR 180 S2	18.5	60	110.0	2935	91.5	0.92	18.6	37.7	6.8	2.6	15.7	51.2	15.7	5220	0.105	165
KV1R 200 L2	KVOR 180 M2	22.0	71	153.0	2950	90.9	0.92	22.0	49.5	7.2	2.8	18.7	60.5	18.3	5000	0.128	196
KV1R 200 LX2	KVOR 200 M2	30.0	97	169.0	2955	90.8	0.89	31.0	56.5	6.4	2.3	25.5	82.4	25.5	5000	0.193	277
KV1R 225 M2	KVOR 200 L2	37.0	120	209.0	2955	92.0	0.90	37.5	68.5	6.7	2.3	33.3	107.6	32.9	5000	0.220	292
KV1R 250 M2	KVOR 225 M2	45.0	145	265.0	2955	93.5	0.91	45.0	90	7.5	2.6	40.5	130.9	40.1	4500	0.375	360
KV1R 280 S2	KVOR 250 S2	55.0	177	322.0	2970	94.5	0.92	53.0	107	7.5	2.6	49.5	159.2	47.7	4300	0.650	490
KV1R 280 M2	KVOR 250 M2	75.0	241	473.0	2970	94.5	0.91	73.0	158	8.5	2.8	67.5	217.0	65.7	4300	0.675	510
KV1R 315 S2	KVOR 280 S2	90.0	289	506.0	2980	93.5	0.90	89.0	168	8.5	2.5	81.0	259.6	77.9	3800	1.21	720
KV1R 315 M2	KVOR 280 M2	110.0	353	640.0	2975	93.5	0.91	108.0	252	8.5	2.4	99.0	317.8	95.4	3800	1.44	800
KV1R 315 MX2	KVOR 315 S2	132.0	424	810.0	2980	93.5	0.90	131.0	272	8.5	2.6	118.8	380.7	111.6	3600	1.76	980
KV1R 315 MY2	KVOR 315 M2	160.0	515	1150.0	2980	94.0	0.88	162.0	328	10.0	3.1	144.0	461.5	136.8	3600	2.82	1170
KV1R 315 L2	KVOR 315 L2	200.0	642	1280.0	2980	94.5	0.91	195.0	427	8.7	2.7	180.0	576.8	168.3	3600	3.66	1460
KV1R 315 LX2	KVOR 315 LX2	250.0	803	1420.0	2985	95.5	0.92	238.0	461	9.0	2.4	225.0	719.8	212.4	3600	4.43	1630
KV2R 355 MY2		280.0	897	1760.0	2990	95.0	0.87	283.0	600	9.5	3.5	270.0	862.4	257.4	3600	4.20	2000
KV2R 355 M2		300.0	961	1950.0	2985	95.2	0.92	286.0	641	9.0	2.7	270.0	863.8	257.4	3600	4.20	2000
KV2R 355 MX2		340.0	1088	2170.0	2990	95.5	0.90	331.0	757	10.0	3.5	306.0	977.4	294.3	3600	5.50	2200
KV2R 355 LY2		370.0	1185	2350.0	2985	95.0	0.92	354.0	786	6.5	2.7	342.0	1094.2	321.3	3600	7.10	2400
KV2R 355 L2		410.0	1312	2446.0	2988	95.5	0.92	391.0	811	10.0	3.1	378.0	1208.1	354.6	3600	7.10	2400
Synchronous speed 1500 rpm – 4-pole version																	
KV1R 132 S4	KVOR 112 M4	4.0	27	56.0	1440	85.7	0.89	4.3	10.1	6.5	3.0	3.2	21.2	3.5	2610	0.01500	50
KV1R 132 M4	KVOR 132 S4	5.5	36	73.0	1450	87.0	0.84	6.4	14.5	6.0	2.9	4.4	29.0	5.0	2610	0.0280	70
KV1R 160 M4	KVOR 132 M4	7.5	49	114.0	1450	88.4	0.85	8.4	21.4	6.8	3.3	6.0	39.5	6.7	2610	0.0350	92
KV1R 160 L4	KVOR 160 S4	11.0	72	151.0	1465	89.4	0.86	12.2	28.4	7.3	3.0	8.8	57.4	9.6	2610	0.0780	120
KV1R 180 M4	KVOR 160 MX4	15.0	98	199.0	1460	90.0	0.86	16.2	36.5	6.8	2.9	12.0	78.5	12.8	2610	0.0900	144
KV1R 180 L4	KVOR 180 S4	18.5	120	248.0	1475	89.8	0.83	20.5	44.5	6.4	2.7	14.8	95.8	16.4	2610	0.1380	168
KV1R 200 L4	KVOR 180 M4	22.0	143	281.0	1475	90.1	0.85	24.0	49.5	6.7	2.6	17.6	114.0	18.8	2610	0.1680	211
KV1R 225 S4	KVOR 200 M4	30.0	195	352.0	1475	90.5	0.84	33.0	62.5	6.5	2.4	24.0	155.4	25.2	2610	0.2750	271
KV1R 225 M4	KVOR 200 L4	37.0	241	433.0	1475	90.6	0.86	40.0	75.5	6.4	2.3	29.6	191.6	30.8	2610	0.3130	300
KV1R 250 M4	KVOR 225 M4	45.0	291	469.0	1475	93.5	0.86	47.0	83	7.0	2.3	36.0	233.1	37.6	2610	0.5250	375
KV1R 280 S4	KVOR 250 S4	55.0	355	680.0	1485	93.0	0.83	60.0	137	8.8	2.5	46.8	300.6	48.5	2610	0.9500	525
KV1R 280 M4	KVOR 250 M4	75.0	484	820.0	1485	93.6	0.85	79.0	166	7.8	2.2	63.8	410.0	65.5	2610	1.10	580
KV1R 315 S4	KVOR 280 S4	90.0	579	1075.0	1490	93.5	0.84	96.0	191	8.4	2.4	81.0	519.2	82.8	2610	1.96	740
KV1R 315 M4	KVOR 280 M4	110.0	707	1200.0	1485	93.8	0.84	117.0	217	8.4	2.2	99.0	636.7	101.7	2610	2.27	840
KV1R 315 MX4	KVOR 315 S4	132.0	852	1350.0	1485	93.5	0.84	141.0	243	7.5	2.0	118.8	764.0	120.6	2610	2.73	1000
KV1R 315 MY4	KVOR 315 M4	160.0	1029	1740.0	1490	93.8	0.87	164.0	304	8.0	2.2	144.0	923.0	142.2	2610	4.82	1200
KV1R 315 L4	KVOR 315 L4	200.0	1286	2650.0	1490	94.5	0.86	206.0	452	9.0	2.7	180.0	1153.7	173.7	2610	5.93	1510
KV1R 315 LX4	KVOR 315 LX4	250.0	1602	3600.0	1490	94.8	0.87	253.0	609	10.0	2.9	225.0	1442.1	221.4	2610	6.82	1630
KV2R 355 MY4		280.0	1795	4600.0	1493	95.3	0.83	296.0	817	8.0	3.3	285.0	1823.0	294.5	2610	7.9	2150
KV2R 355 M4		300.0	1923	4680.0	1493	95.6	0.84	312.0	835	8.8	3.1	285.0	1823.0	294.5	2610	7.9	2150
KV2R 355 MX4		340.0	2173	5750.0	1495	95.8	0.88	337.0	980	8.6	3.4	323.0	2063.3	332.5	2610	9.5	2400
KV2R 355 LY4		370.0	2372	6080.0	1495	95.8	0.84	385.0	1072	9.0	3.3	361.0	2306.1	381.0	2610	10.00	2500
KV2R 355 L4		410.0	2628	6800.0	1495	95.8	0.81	442.0	1258	8.8	3.3	399.0	2548.8	438.0	2610	10.00	2500

Three-phase motors with squirrel-cage rotor Special insulation for converter-fed operation without filter up to 690 V

with surface cooling, duty type S8, S9
for rated voltage, thermal class 155 (F), degree of protection IP 55, 50 Hz

Motor selection data													Design point 690 V, 50 Hz					
Type IEC/DIN	Type Progressive	P _B	M _B	M _{max}	n	η _B	cosφ _B	I _B	I _{max}	I _A /I _B	M _K /M _B	Setting range 1:5, 1:10			M _K /M _B	J	m	
						(IEC/EN 60034-2)		690 V				P _{1.5, 1:10} M _{1.5, 1:10} I _{1.5, 1:10}						
		kW	Nm	Nm	rpm	%	-	A	A	-	-	kW	Nm	A	rpm	kgm ²	kg	
Synchronous speed 1000 rpm – 6-pole version																		
KV1R 132 M6	KVOR 112 MX6	2.2	22	42.0	955	78.2	0.82	2.9	6.1	5.7	2.7	1.7	16.5	2.2	1740	0.0230	53	
KV1R 132 MX6	KVOR 132 S6	3.0	30	65.0	955	80.0	0.80	4.1	9.7	6.0	3.1	2.3	22.5	2.9	1740	0.0430	70	
KV1R 132 MX6	KVOR 132 S6	4.0	40	64.0	955	83.0	0.83	4.9	8.7	5.0	2.3	3.0	30.0	3.7	1740	0.0430	70	
KV1R 160 M6	KVOR 132 M6	5.5	55	96.0	960	85.0	0.82	6.7	13.3	5.5	2.5	4.4	43.8	5.3	1740	0.0530	86	
KV1R 160 L6	KVOR 160 S6	7.5	74	119.0	965	85.2	0.86	8.7	15.7	5.0	2.3	6.0	59.4	6.9	1740	0.1130	114	
KV1R 180 L6	KVOR 160 M6	11.0	109	206.0	965	86.0	0.83	13.0	27.2	6.0	2.7	8.8	87.1	10.4	1740	0.1450	136	
KV1R 200 L6	KVOR 180 S6	15.0	147	264.0	975	85.8	0.87	17.0	32	5.7	2.3	12.8	124.9	14.0	1740	0.2280	181	
KV1R 200 LX6	KVOR 180 M6	18.5	182	339.0	975	84.6	0.80	23.0	45	5.3	2.4	15.7	154.0	17.0	1740	0.2680	200	
KV1R 225 M6	KVOR 200 M6	22.0	217	406.0	970	87.4	0.89	23.5	46	5.8	2.4	20.9	205.8	21.9	1740	0.4430	265	
KV1R 250 M6	KVOR 225 M6	30.0	294	473.0	975	91.0	0.89	31.0	56	6.5	2.3	28.5	279.2	29.5	1740	0.8250	360	
KV1R 280 S6	KVOR 250 S6	37.0	361	505.0	980	92.0	0.87	39.0	60	6.0	2.0	35.2	342.5	36.6	1740	1.28	465	
KV1R 280 M6	KVOR 250 M6	45.0	439	737.0	980	92.5	0.88	47.0	87	6.5	2.4	42.8	416.6	44.2	1740	1.48	520	
KV1R 315 S6	KVOR 280 S6	55.0	533	1050.0	990	92.5	0.85	59.0	125	8.2	2.6	52.3	504.0	53.7	1740	2.63	690	
KV1R 315 M6	KVOR 280 M6	75.0	724	1300.0	990	92.8	0.86	79.0	157	7.5	2.4	71.3	687.3	71.7	1740	3.33	800	
KV1R 315 MX6	KVOR 315 S6	90.0	868	1800.0	990	92.7	0.85	96.0	206	8.3	2.7	85.5	824.8	86.5	1740	3.60	880	
KV1R 315 MY6	KVOR 315 M6	110.0	1061	1850.0	990	93.0	0.86	115.0	217	7.6	2.4	104.5	1008.1	104.5	1740	6.00	1050	
KV1R 315 L6	KVOR 315 L6	132.0	1280	2200.0	990	93.0	0.86	138.0	258	7.5	2.3	125.4	1209.7	123.5	1740	6.67	1250	
KV1R 315 LX6	KVOR 315 LX6	160.0	1543	3150.0	990	93.5	0.84	170.0	348	8.3	2.7	152.0	1466.3	153.9	1740	8.6	1460	
KV2R 355 MY6		180.0	1730	3650.0	995	94.5	0.79	202.0	467	7.5	2.7	190.0	1823.6	205.2	1740	8.2	1650	
KV2R 355 M6		200.0	1922	4200.0	995	94.5	0.79	224.0	539	7.8	2.9	190.0	1823.6	205.2	1740	8.2	1650	
KV2R 355 MX6		250.0	2400	4650.0	995	94.5	0.84	264.0	562	7.4	2.5	237.5	2279.5	248.0	1740	12.1	2200	
KV2R 355 LY6		300.0	2879	6600.0	995	95.0	0.78	339.0	783	8.3	3.0	285.0	2735.4	319.2	1740	14.0	2400	
Synchronous speed 750 rpm – 8-pole version																		
KV1R 132 M8	KVOR 112 MX8	1.5	20	33.0	705	75.5	0.76	2.3	4.2	4.5	2.3	1.1	15.2	1.7	1305	0.02300	53	
KV1R 160 M8	KVOR 132 S8	2.2	30	48.0	705	78.0	0.75	3.2	5.7	4.5	2.3	1.7	22.4	2.3	1305	0.0430	70	
KV1R 160 M8	KVOR 132 S8	3.0	40	54.0	710	79.3	0.78	4.1	6	4.0	1.9	2.3	30.3	3.1	1305	0.0430	70	
KV1R 160 MX8	KVOR 132 M8	4.0	54	79.0	710	81.4	0.78	5.2	8.5	4.5	2.1	3.2	43.0	4.2	1305	0.0530	86	
KV1R 160 L8	KVOR 160 S8	5.5	72	106.0	725	83.0	0.78	7.2	12.2	4.5	2.1	4.4	58.0	5.7	1305	0.1130	114	
KV1R 180 L8	KVOR 160 M8	7.5	100	146.0	720	85.0	0.78	9.6	15.7	4.5	2.1	6.8	89.5	8.6	1305	0.1450	136	
KV1R 200 L8	KVOR 180 S8	11.0	145	233.0	725	86.5	0.79	13.6	24.3	5.0	2.3	9.9	130.4	12.2	1305	0.228	175	
-	KVOR 180 M8	15.0	198	304.0	725	87.5	0.80	18.0	30.7	5.0	2.2	13.5	177.8	16.2	1305	0.268	200	
KV1R 225 M8	KVOR 200 M8	18.5	244	375.0	725	89.2	0.84	20.6	35.4	5.0	2.2	16.7	219.3	18.5	1305	0.440	265	
KV1R 250 M8	KVOR 225 M8	22.0	288	443.0	730	90.2	0.79	26.0	44.6	5.5	2.2	19.8	259.0	23.4	1305	0.825	360	
KV1R 280 S8	KVOR 250 S8	30.0	390	546.0	735	91.0	0.80	35.0	54	5.5	2.0	28.5	370.3	32.8	1305	1.35	465	
KV1R 280 M8	KVOR 250 M8	37.0	481	808.0	735	91.5	0.77	44.0	82	6.0	2.4	35.2	456.7	41.8	1305	1.55	520	
KV1R 315 S8	KVOR 280 S8	45.0	581	910.0	740	91.5	0.79	52.0	90	6.5	2.0	42.8	551.7	48.0	1305	2.63	690	
KV1R 315 M8	KVOR 280 M8	55.0	710	1310.0	740	92.0	0.78	64.0	130	7.7	2.5	52.3	674.3	58.0	1305	3.33	800	
KV1R 315 MX8	KVOR 315 S8	75.0	968	1491.0	740	92.0	0.80	85.0	145	6.5	2.0	71.3	919.5	78.9	1305	3.60	880	
KV1R 315 MY8	KVOR 315 M8	90.0	1162	2380.0	743	93.5	0.79	102.0	229	8.0	2.7	85.5	1099.0	93.6	1305	6.00	1050	
KV1R 315 L8	KVOR 315 L8	110.0	1420	2650.0	743	94.0	0.79	124.0	255	7.7	2.5	104.5	1343.2	111.2	1305	6.76	1250	
KV1R 315 LX8	KVOR 315 LX8	132.0	1704	3800.0	744	94.5	0.77	151.0	352	8.6	3.0	129.4	1660.5	144.1	1305	8.71	1430	
KV2R 355 MY8		145.0	2329	3887.0	745	94.0	0.75	172.0	396	6.7	2.7	156.8	2010.0	178.4	1305	9.5	1600	
KV2R 355 M8		160.0	2057	4650.0	745	94.5	0.70	202.0	501	7.0	2.9	156.8	2010.0	178.4	1305	9.5	1600	
KV2R 355 MX8		180.0	2310	5200.0	745	94.5	0.78	204.0	507	7.5	2.9	196.0	2512.5	219.5	1305	13.4	2200	
KV2R 355 LY8		210.0	2695	5787.0	745	94.0	0.76	246.0	615	8.2	2.8	225.4	2889.4	253.8	1305	15.8	2400	

Three-phase motors with squirrel-cage rotor
Special insulation for converter-fed operation without filter up to 690 V

with surface cooling, duty type S8, S9
 for rated voltage, thermal class 155 (F), degree of protection IP 55, 50 Hz

Motor selection data													Design point 690 V, 50 Hz				
Type IEC/DIN	Type Progressive	P _B	M _B	M _{max}	n	η _B	cosφ _B	I _B	I _{max}	I _A /I _B	M _K /M _B	Setting range 1:5, 1:10 P _{1:5, 1:10} M _{1:5, 1:10} I _{1:5, 1:10}			M _K /M _B	J	m
		kW		Nm	Nm	rpm	%	690 V		-	-	kW	Nm	A	rpm	kgm ²	kg
Synchronous speed 600 rpm – 10-pole version																	
KV1R 132 M10	KVOR 112 MX10	1.1	18.4	32.0	570	67.0	0.65	2.1	4	3.7	2.5	0.9	14.7	2.9	1044	0.023	53
KV1R 132 MX10	KVOR 132 S10	1.5	25.1	46	570	71.5	0.65	2.7	5.5	3.8	2.6	1.2	20.1	3.8	1044	0.043	70
KV1R 160 M10	KVOR 132 M10	2.2	36.5	56	575	75.0	0.65	3.8	6.4	3.7	2.2	1.8	29.2	5.2	1044	0.053	86
KV1R 160 L10	KVOR 160 S10	3.0	49.8	77	575	77.0	0.65	5.0	8.6	3.7	2.2	2.4	39.9	7.0	1044	0.113	114
KV1R 180 L10	KVOR 160 M10	5.5	91.3	134	575	80.5	0.68	8.4	13.9	4.0	2.1	4.4	73.1	11.6	1044	0.145	136
KV1R 200 L10	KVOR 180 S10	6.0	100	147	575	82.0	0.68	9.0	15.1	3.9	2.1	4.8	79.7	12.4	1044	0.228	175
KV1R 200 LX10	KVOR 180 M10	9.0	147	278	585	83.0	0.65	14.2	29.6	4.6	2.7	7.7	124.9	20.4	1044	0.268	200
KV1R 225 M10	KVOR 200 M10	13.0	216	318	575	85.0	0.70	18.3	30.1	4.2	2.1	11.1	183.5	26.8	1044	0.440	265
KV1R 250 M10	KVOR 225 M10	17.0	280	412	580	85.0	0.70	24.1	39.4	4.3	2.1	14.5	237.9	34.9	1044	0.825	360
KV1R 280 S10	KVOR 250 S10	22.0	360	403	580	87.0	0.69	31.0	37.7	3.9	1.6	18.7	307.9	45.1	1044	1.35	465
KV1R 280 M10	KVOR 250 M10	27.0	440	524	585	89.5	0.70	36.0	47.5	4.2	1.7	24.3	396.7	55.8	1044	1.55	520
KV1R 315 S10	KVOR 280 S10	34.0	550	770	585	89.0	0.71	45.0	70	4.5	2.0	30.6	499.5	69.8	1044	2.63	690
KV1R 315 M10	KVOR 280 M10	45.0	725	1167	590	91.5	0.75	55.0	97	5.2	2.3	40.5	655.6	85.1	1044	3.33	800
KV1R 315 MX10	KVOR 315 M10	55.0	885	1673	592	92.0	0.74	68	141	6.3	2.7	49.5	798.5	105.3	1044	3.60	880
KV1R 315 L10	KVOR 315 L10	75.0	1210	1863	590	92.0	0.75	91	154	5.5	2.2	71.3	1153.3	149.2	1044	6.76	1250
KV1R 315 LX10		90.0	1445	2225	593	93.0	0.67	122	206	6.0	2.2	86	1376.9	200.0	1044	8.71	1430
KV2R 355M10		110.0	1765	2842	595	93.0	0.69	145	257	6.0	2.3	85.5	1372.3	191.9	1044	9.50	1600
KV2R 355MX10		135.0	2165	3940	595	94.9	0.66	183	366	5.5	2.6	128.3	2058.5	297.4	1044	9.50	1600
KV2R 355LY10		160.0	2565	4489	595	94.5	0.66	214	413	6.0	2.5	152.0	2439.7	355.0	1044	11.60	2100
KV2R 355L10		180.0	2885	4847	595	95.3	0.74	214	396	5.7	2.4	171.0	2744.6	355.0	1044	15.80	2400
Synchronous speed 500 rpm – 12-pole version																	
KV1R 132 M12	KVOR 112 MX12	0.75	15.1	23	475	60.0	0.57	1.9	3.1	3.0	2.2	0.6	12.1	2.6	870	0.023	53
KV1R 132 MX12	KVOR 132 S12	1.1	22.4	38	470	63.0	0.60	2.4	4.6	3.2	2.4	0.9	17.9	3.4	870	0.043	70
KV1R 160 M12	KVOR 132 M12	1.5	29.8	44	480	67.0	0.57	3.3	5.4	3.0	2.1	1.2	23.9	4.6	870	0.053	86
KV1R 160 L12	KVOR 160 S12	2.2	44	74	475	69.5	0.55	4.9	9.1	3.3	2.4	1.8	35.4	6.6	870	0.113	114
KV1R 180 L12	KVOR 160 M12	3.0	59	83	480	77.0	0.60	5.5	8.5	3.4	2.0	2.4	47.8	7.5	870	0.145	136
KV1R 200 L12	KVOR 180 S12	5.5	110	154	475	76.0	0.60	10.1	15.7	3.0	2.0	4.4	88.5	14.0	870	0.228	175
KV1R 200 LX12	KVOR 180 M12	6.0	119	158	480	83.0	0.65	9.6	14.5	3.3	1.9	5.1	101.5	13.6	870	0.268	200
KV1R 225 M12	KVOR 200 M12	9.0	179	276	480	82.0	0.61	15.1	26.1	3.8	2.2	7.7	152.2	22.1	870	0.440	265
KV1R 250 M12	KVOR 225 M12	13.0	258	343	480	83.0	0.68	19.4	28.4	3.6	1.9	11.1	219.8	28.1	870	0.825	360
KV1R 280 S12	KVOR 250 S12	17.0	338	450	480	86.0	0.69	24.1	35.4	3.9	1.9	14.5	287.5	35.3	870	1.350	465
KV1R 280 M12	KVOR 250 M12	20.0	392	466	487	88.0	0.68	28.0	37.1	3.8	1.7	18.0	353.0	43.2	870	1.550	520
KV1R 315 S12	KVOR 280 S12	24.0	469	624	488	87.5	0.63	37.0	54	4.0	1.9	21.6	422.7	56.7	870	2.63	690
KV1R 315 M12	KVOR 280 M12	37.0	721	1009	490	91.0	0.71	48.0	74	4.2	2.0	33.3	649.0	74.3	870	3.33	800
KV1R 315 MX12	KVOR 315 M12	45.0	877	1166	490	91.0	0.72	58.0	85	4.5	1.9	40.5	789.3	89.1	870	3.60	880
KV1R 315 L12	KVOR 315 L12	55.0	1083	1440	485	91.0	0.74	68	100	4.5	1.9	52.3	1028.8	112.1	870	6.76	1250
KV1R 315 LX12		75.0	1455	1630	492	92.5	0.64	106	131	4.5	1.6	71.3	1383.0	173.9	870	8.71	1430
KV2R 355M12		90	1754	1964	490	93.0	0.60	136	168	4.5	1.6	85.5	1666	225	870	9.30	1500
KV2R 355MX12		110.0	2143	2400	490	93.0	0.60	165	203	4.5	1.6	104.5	2036.7	275	870	9.50	1600
KV2R 355LY12		132.0	2572	2881	490	93.0	0.60	200	246	4.5	1.6	125.4	2444.0	330	870	15.80	2400
KV2R 355L12		145.0	2826	3165	490	93.0	0.60	217	268	4.5	1.6	137.8	2684.7	360	870	15.80	2400

Equivalent circuit data

Three-phase motors with squirrel-cage rotor for converter-fed operation without filter up to 420 V

with surface cooling, duty type S8, S9
for rated voltage, thermal class 155 (F), degree of protection IP 55, 50 Hz

Equivalent circuit data		Design point 400 V Δ, 50 Hz					
Type		$R1_w$	$R2_w'$	Rf_g	$X1s$	$X2s'$	$X1_h$
		Ω	Ω	Ω	Ω	Ω	Ω
Synchronous speed 3000 rpm – 2-pole version							
K21R 63 K2	K20R 56 K2	256.5	141.9	18333	63.9	48.6	1590
K21R 63 G2	K20R 56 G2	168	101.1	13581	44.4	33.9	1170
K21R 71 K2	K20R 63 K2	114	66.6	11013	46.2	37.8	942
K21R 71 G2	K20R 63 G2	62.7	45.6	9087	33.3	27.81	864
K21R 80 K2	K20R 71 K2	45.9	28.89	7365	28.92	21.96	615
K21R 80 G2	K20R 71 G2	27.69	19.2	5277	18.87	14.7	438
K21R 90 S2	K20R 80 K2	12.3	12.84	4923	16.32	13.71	468
K21R 90 L2	K20R 80 G2	10.11	8.88	3300	10.14	8.7	296.1
K21R 100 L2	K20R 90 L2	7.47	6.03	2541	9.18	10.08	262.8
K21R 112 M2	K20R 100 S2	4.83	3.33	1887	6.75	7.35	145.2
K21R 112 MX2	K20R 100 L2	3.06	2.64	1701	5.16	5.88	135.3
K21R 132 S2T	K20R 100 L2	3.06	2.64	1701	5.16	5.88	135.3
K21R 112 MV2	K20R 100 LV2	1.86	1.83	1350	3.54	4.2	92.7
K21R 132 SX2T	K20R 100 LV2	1.86	1.83	1350	3.54	4.2	92.7
K21R 132 S2	K20R 112 MY2	4.725	2.78	2825	4.46	7.29	166.7
K21R 132 SX2	K20R 112 M2	2.03	1.82	1574	3.95	3.77	111.5
K21R 160 M2	K20R 132 M2	1.33	1.16	1481	2.24	3.047	111.2
K21R 160 MX2	K20R 160 S2	0.8092	0.68	1228	1.74	2.79	93.6
K21R 160 L2	K20R 160 M2	0.7	0.58	1297	1.51	2.55	98.9
K21R 180 M2	K20R 180 S2	0.4662	0.44	930	1.52	2.03	78.1
K21R 200 L2	K20R 180 M2	0.294	0.305	721	1.01	1.43	57.5
K21R 200 LX2	K20R 200 M2	0.2016	0.218	533	0.89	1.46	47.1
K21R 225 M2	K20R 200 L2	0.1498	0.166	441	0.68	1.16	38.6
K21R 250 M2	K20R 225 M2	0.1036	0.12	433	0.57	0.94	30.4
K21R 280 S2	K20R 250 S2	0.084	0.074	352	0.45	0.78	29.6
K21R 280 M2	K20R 250 M2	0.056	0.05	236	0.31	0.55	19.8
K21R 315 S2	K20R 280 S2	0.049	0.04	273	0.32	0.58	21.1
K21R 315 M2	K20R 280 M2	0.0364	0.03	226	0.24	0.46	17.5
K21R 315 MX2	K20R 315 S2	0.0252	0.028	190	0.18	0.37	14.6
K21R 315 MY2	K20R 315 M2	0.0196	0.016	180	0.14	0.27	10.8
K21R 315 L2	K20R 315 L2	0.01974	0.0135	366	0.13	0.34	12.63
K21R 315 LX2	K20R 315 LX2	0.01428	0.0102	266	0.096	0.3	9.7
K22R 355 MY2		0.00828	0.0053	198	0.1094	0.2049	4.862
K22R 355 M2		0.00851	0.00664	262	0.1127	0.2062	6.448
K22R 355 MX2		0.00526	0.0044	200	0.0779	0.1707	5.451
K22R 355 LY2		0.00667	0.00486	246	0.0863	0.2018	8.204
K22R 355 L2		0.00563	0.00372	192	0.0661	0.1545	5.412

**Three-phase motors with squirrel-cage rotor
for converter-fed operation without filter up to 420 V**

with surface cooling, duty type S8, S9
for rated voltage, thermal class 155 (F), degree of protection IP 55, 50 Hz

Equivalent circuit data		Design point 400 V Δ, 50 Hz					
Type		$R1_w$ Ω	$R2_w$ Ω	RFe Ω	$X1s$ Ω	$X2s'$ Ω	$X1_h$ Ω
Synchronous speed 1500 rpm – 4-pole version							
K21R 63 K4	K20R 56 K4	398.4	216	27714	124.5	114	1623
K21R 63 G4	K20R 56 G4	241.8	163.8	20997	93.3	87.6	1272
K21R 71 K4	K20R 63 K4	187.8	104.1	15951	86.1	86.1	1149
K21R 71 G4	K20R 63 G4	111.3	75.3	11781	62.4	64.2	885
K21R 80 K4	K20R 71 K4	58.8	40.2	7875	47.7	43.2	543
K21R 80 G4	K20R 71 G4	39.6	31.2	6258	36.9	33.9	444
K21R 90 S4	K20R 80 K4	30	20.4	5802	17.88	14.79	414
K21R 90 L4	K20R 80 G4	21.36	16.05	4875	13.77	11.7	351
K21R 100 L4	K20R 90 L4	11.04	9.6	3561	10.23	9.57	257.1
K21R 100 LX4	K20R 100 S4	7.11	5.64	2586	7.47	7.53	187.5
K21R 112 M4	K20R 100 L4	5.46	4.29	1917	5.37	5.28	137.7
K21R 112 MX4	K20R 100 LX4	3.39	3.48	1329	3.57	3.84	94.92
K21R 132 S4T	K20R 100 LX4	3.39	3.48	1329	3.57	3.84	94.92
K21R 132 S4	K20R 112 M4	4.466	3.03	2182	4.53	4.58	150.3
K21R 132 M4	K20R 132 S4	2.8182	1.73	1715	3.32	3.82	100.3
K21R 160 M4	K20R 132 M4	1.6534	1.14	1200	2.194	2.88	78.2
K21R 160 L4	K20R 160 S4	1.0206	0.673	800	1.78	2.79	62.9
K21R 180 M4	K20R 160 M4	0.791	0.555	686	1.4	2.25	50.7
K21R 180 L4	K20R 180 S4	0.4942	0.41	692	1.34	2.31	43.7
K21R 200 L4	K20R 180 M4	0.3388	0.31	557	0.99	1.79	35.3
K21R 225 S4	K20R 200 M4	0.2044	0.209	444	0.85	1.62	30.4
K21R 225 M4	K20R 200 L4	0.1554	0.178	393	0.72	1.4	27
K21R 250 M4	K20R 225 M4	0.1232	0.12	327	0.63	1.19	24.8
K21R 280 S4	K20R 250 S4	0.0728	0.072	254	0.44	0.96	18.4
K21R 280 M4	K20R 250 M4	0.0588	0.06	225	0.38	0.83	16.3
K21R 315 S4	K20R 280 S4	0.0504	0.042	191	0.26	0.59	12.5
K21R 315 M4	K20R 280 M4	0.042	0.036	176	0.23	0.53	11.4
K21R 315 MX4	K20R 315 S4	0.0364	0.033	170	0.2	0.49	10.3
K21R 315 MY4	K20R 315 M4	0.0266	0.018	157	0.14	0.37	8.8
K21R 315 L4	K20R 315 L4	0.021	0.0149	228	0.119	0.39	7.86
K21R 315 LX4	K20R 315 LX4	0.014	0.011	171	0.088	0.37	5.81
K22R 355 MY4		0.00786	0.00903	185	0.1209	0.237	3.988
K22R 355 M4		0.0066	0.00699	160	0.092	0.1143	3.124
K22R 355 MX4		0.0049	0.00551	150	0.0808	0.1748	3.008
K22R 355 LY4		0.00414	0.00526	105	0.0671	0.1313	2.265
K22R 355 L4		0.00434	0.004	90	0.059	0.094	1.53

Three-phase motors with squirrel-cage rotor for converter-fed operation without filter up to 420 V

with surface cooling, duty type S8, S9
for rated voltage, thermal class 155 (F), degree of protection IP 55, 50 Hz

Equivalent circuit data		Design point 400 V Δ, 50 Hz					
Type		R _{1w} Ω	R _{2w} Ω	R _F Ω	X _{1s} Ω	X _{2s'} Ω	X _{1h} Ω
Synchronous speed 1000 rpm – 6-pole version							
K21R 63 K6	K20R 56 K6	357.9	299.4	32235	244.8	259.2	1446
K21R 63 G6	K20R 56 G6	261.6	248.4	26829	203.4	216.9	1227
K21R 71 K6	K20R 63 K6	129.3	109.5	13734	145.5	136.8	645
K21R 71 G6	K20R 63 G6	112.5	99.9	13551	134.4	128.1	726
K21R 80 K6	K20R 71 K6	112.5	70.2	12150	51.3	53.1	708
K21R 80 G6	K20R 71 G6	68.1	50.4	8946	36.6	38.4	522
K21R 90 S6	K20R 80 K6	38.1	26.22	5430	25.59	30.6	366
K21R 90 L6	K20R 80 G6	25.77	19.77	4194	19.05	23.37	287.1
K21R 100 L6	K20R 90 L6	19.11	12.84	3909	15.21	17.73	238.5
K21R 112 M6	K20R 100 L6	13.44	9.06	3240	8.49	7.41	201
K21R 132 S6T	K20R 100 LX6						
K21R 132 S6	K20R 112 M6	8.624	6	2697	7.68	7.01	176.8
K21R 132 M6	K20R 112 MX6	5.25	4.12	1920	5.24	4.9	123
K21R 132 MX6	K20R 132 S6	3.906	2.91	1685	4.92	6.32	114.7
K21R 160 M6	K20R 132 M6	2.338	2.24	1340	3.71	4.9	91.1
K21R 160 L6	K20R 160 S6	1.694	1.31	1171	2.59	3.43	81.6
K21R 180 L6	K20R 160 M6	0.938	0.83	716	1.58	2.2	48.4
K21R 200 L6	K20R 180 S6	0.756	0.68	711	1.66	2.04	57
K21R 200 LX6	K20R 180 M6	0.56	0.54	572	1.3	1.63	46.1
K21R 225 M6	K20R 200 M6	0.378	0.385	480	1.1	1.38	41.9
K21R 250 M6	K20R 225 M6	0.2856	0.265	407	0.88	1.32	35.8
K21R 280 S6	K20R 250 S6	0.2072	0.185	338	0.74	1.13	27.4
K21R 280 M6	K20R 250 M6	0.1498	0.142	271	0.57	0.89	21.9
K21R 315 S6	K20R 280 S6	0.0938	0.081	210	0.48	0.74	18.4
K21R 315 M6	K20R 280 M6	0.0742	0.063	176	0.37	0.6	15.1
K21R 315 MX6	K20R 315 S6	0.0588	0.05	138	0.3	0.48	11.8
K21R 315 MY6	K20R 315 M6	0.0476	0.041	153	0.27	0.46	11.3
K21R 315 L6	K20R 315 L6	0.035	0.035	218	0.225	0.44	9.72
K21R 315 LX6	K20R 315 LX6	0.02338	0.025	126	0.159	0.34	6.22
K22R 355 MY6		0.0171	0.0166	165	0.183	0.341	5.425
K22R 355 M6		0.0121	0.01275	132	0.1393	0.2627	3.685
K22R 355 MX6		0.01002	0.01131	140	0.1228	0.2364	4.106
K22R 355 LY6		0.0071	0.00823	85	0.0886	0.1722	2.426
Synchronous speed 750 rpm – 8-pole version							
K21R 71 K8	K20R 63 K8	368.4	281.1	37266	195.6	266.7	1164
K21R 71 G8	K20R 63 G8	256.5	221.1	28521	153.3	209.1	900
K21R 80 K8	K20R 71 K8	235.2	145.2	24516	100.2	118.8	1011
K21R 80 G8	K20R 71 G8	139.5	97.5	16410	66.6	79.8	678
K21R 90 S8	K20R 80 K8	78.6	51.9	10836	47.4	65.4	480
K21R 90 L8	K20R 80 G8	53.1	40.2	8472	36.6	51	378
K21R 100 L8	K20R 90 L8	36.6	23.31	6696	25.89	34.5	273
K21R 100 LX8	K20R 100 S8	27.87	20.85	6867	19.29	17.34	276.9
K21R 112 M8	K20R 100 L8	18.39	13.14	5172	13.95	12.81	209.7
K21R 132 S8T	K20R 100 LX8						
K21R 132 S8	K20R 112 M8	13.006	9.43	4148	12.15	11.82	170.8
K21R 132 M8	K20R 112 MX8	9.212	7.3	3333	9.28	9.21	137.2
K21R 160 M8	K20R 132 S8	6.244	5.04	2667	8.34	11.31	128
K21R 160 MX8	K20R 132 M8	3.962	3.7	1967	6.02	8.3	92.1
K21R 160 L8	K20R 160 S8	2.478	1.86	1515	3.55	5.19	67.4
K21R 180 L8	K20R 160 M8	1.526	1.37	1148	2.57	3.9	50.6
K21R 200 L8	K20R 180 S8	0.952	0.85	795	2.1	2.7	39.8
	K20R 180 M8						
K21R 225 S8		0.756	0.77	762	1.88	2.48	39.3
K21R 225 M8	K20R 200 M8	0.602	0.59	688	1.7	2.29	39.7
K21R 250 M8	K20R 225 M8	0.35	0.33	437	1.08	1.7	25.1
K21R 280 S8	K20R 250 S8	0.266	0.23	425	0.93	1.54	21.6
K21R 280 M8	K20R 250 M8	0.161	0.17	310	0.67	1.13	15.8
K21R 315 S8	K20R 280 S8	0.133	0.11	295	0.65	1.07	15.8
K21R 315 M8	K20R 280 M8	0.0924	0.084	235	0.5	0.82	12.5
K21R 315 MX8	K20R 315 S8	0.0812	0.07	191	0.42	0.69	10.2
K21R 315 MY8	K20R 315 M8	0.0532	0.05	169	0.33	0.6	8.4
K21R 315 L8	K20R 315 L8	0.0434	0.0444	229	0.288	0.53	7.38
K21R 315 LX8	K20R 315 LX8	0.02856	0.031	160	0.199	0.37	4.82
K22R 355 MY8		0.0198	0.01786	165	0.2457	0.3049	4.91
K22R 355 M8		0.01474	0.01538	160	0.2027	0.2487	3.722
K22R 355 MX8		0.01169	0.01356	126	0.1639	0.2044	3.457
K22R 355 LY8		0.00851	0.01101	100	0.1304	0.1633	2.464

**Three-phase motors with squirrel-cage rotor
for converter-fed operation without filter up to 500 V**

with surface cooling, duty type S8, S9
for rated voltage, thermal class 155 (F), degree of protection IP 55, 50 Hz

Equivalent circuit data		Design point 500 V Δ, 50 Hz					
Type		$R1_w$ Ω	$R2_w$ Ω	RFe Ω	$X1s$ Ω	$X2s'$ Ω	$X1_h$ Ω
Synchronous speed 3000 rpm – 2-pole version							
KU1R 63 KU	KUOR 56 KU	400.78	221.72	28645	99.84	75.94	2484
KU1R 63 G2	KUOR 56 G2	262.5	157.97	21220	69.38	52.97	1828
KU1R 71 KU	KUOR 63 KU	178.13	104.06	17208	72.19	59.06	1472
KU1R 71 G2	KUOR 63 G2	97.97	71.25	14198	52.03	43.45	1350
KU1R 80 KU	KUOR 71 KU	71.72	45.14	11508	45.19	34.31	961
KU1R 80 G2	KUOR 71 G2	43.27	30	8245	29.48	22.97	684
KU1R 90 S2	KUOR 80 KU	19.22	20.06	7692	25.5	21.42	731
KU1R 90 L2	KUOR 80 G2	15.8	13.88	5156	15.84	13.59	463
KU1R 100 L2	KUOR 90 L2	11.67	9.42	3970	14.34	15.75	411
KU1R 112 M2	KUOR 100 S2	7.55	5.2	2948	10.55	11.48	227
KU1R 112 MX2		4.78	4.13	2658	8.06	9.19	211
KU1R 132 S2 T	KUOR 100 L2	4.78	4.13	2658	8.06	9.19	211
KU1R 112 MV2		2.91	2.86	2109	5.53	6.56	145
KU1R 132 SX2T	KUOR 100 LV2	2.91	2.86	2109	5.53	6.56	145
KU1R 132 S2	KUOR 112 MY2	7.383	4.344	4414	6.97	11.39	260
KU1R 132 SX2	KUOR 112 M2	3.172	2.844	2459	6.17	5.89	174
KU1R 160 M2	KUOR 132 M2	2.078	1.813	2314	3.5	4.76	174
KU1R 160 MX2	KUOR 160 S2	1.264	1.063	1919	2.72	4.36	146
KU1R 160 L2	KUOR 160 M2	1.094	0.906	2027	2.36	3.98	155
KU1R 180 M2	KUOR 180 S2	0.728	0.688	1453	2.38	3.17	122
KU1R 200 L2	KUOR 180 M2	0.459	0.477	1127	1.58	2.23	89.8
KU1R 200 LX2	KUOR 200 M2	0.315	0.341	833	1.39	2.28	73.6
KU1R 225 M2	KUOR 200 L2	0.234	0.259	689	1.06	1.81	60.3
KU1R 250 M2	KUOR 225 M2	0.162	0.188	677	0.89	1.47	47.5
KU1R 280 S2	KUOR 250 S2	0.131	0.116	550	0.7	1.22	46.3
KU1R 280 M2	KUOR 250 M2	0.088	0.078	369	0.48	0.86	30.9
KU1R 315 S2	KUOR 280 S2	0.077	0.063	427	0.5	0.91	33
KU1R 315 M2	KUOR 280 M2	0.0569	0.0469	353	0.375	0.719	27.3
KU1R 315 MX2	KUOR 315 S2	0.0394	0.0438	297	0.281	0.578	22.8
KU1R 315 MY2	KUOR 315 M2	0.0306	0.025	281	0.219	0.422	16.9
KU1R 315 L2	KUOR 315 L2	0.03084	0.02109	572	0.2031	0.5313	19.73
KU1R 315 LX2	KUOR 315 LX2	0.0223	0.0159	416	0.15	0.469	15.16
KU2R 355 MY2		0.0129	0.0083	309	0.171	0.32	7.597
KU2R 355 M2		0.0133	0.0104	409	0.176	0.322	10.075
KU2R 355 MX2		0.0082	0.0069	313	0.122	0.267	8.517
KU2R 355 LY2		0.0104	0.0076	384	0.135	0.315	12.819
KU2R 355 L2		0.0088	0.0058	300	0.103	0.241	8.456

Three-phase motors with squirrel-cage rotor for converter-fed operation without filter up to 500 V

with surface cooling, duty type S8, S9
for rated voltage, thermal class 155 (F), degree of protection IP 55, 50 Hz

Equivalent circuit data		Design point 500 V Δ, 50 Hz					
Type		$R1_w$ Ω	$R2_w$ Ω	Rf_e Ω	$X1s$ Ω	$X2s'$ Ω	$X1_h$ Ω
Synchronous speed 1500 rpm – 4-pole version							
KU1R 63 K4	KUOR 56 K4	622.5	337.5	43303	194.53	178.13	2536
KU1R 63 G4	KUOR 56 G4	377.81	255.94	32808	145.78	136.88	1988
KU1R 71 K4	KUOR 63 K4	293.44	162.66	24923	134.53	134.53	1795
KU1R 71 G4	KUOR 63 G4	173.91	117.66	18408	97.5	100.31	1383
KU1R 80 K4	KUOR 71 K4	91.88	62.81	12305	74.53	67.5	848
KU1R 80 G4	KUOR 71 G4	61.88	48.75	9778	57.66	52.97	694
KU1R 90 S4	KUOR 80 K4	46.88	31.88	9066	27.94	23.11	647
KU1R 90 L4	KUOR 80 G4	33.38	25.08	7617	21.52	18.28	548
KU1R 100 L4	KUOR 90 L4	17.25	15	5564	15.98	14.95	402
KU1R 100 LX4	KUOR 100 S4	11.11	8.81	4041	11.67	11.77	293
KU1R 112 M4	KUOR 100 L4	8.53	6.7	2995	8.39	8.25	215
KU1R 112 MX4		5.3	5.44	2077	5.58	6	148
KU1R 132 S4 T		5.3	5.44	2077	5.58	6	148
KU1R 132 S4	KUOR 112 M4	6.9781	4.734	3409	7.08	7.16	235
KU1R 132 M4	KUOR 132 S4	4.4034	2.703	2680	5.19	5.97	157
KU1R 160 M4	KUOR 132 M4	2.5834	1.781	1875	3.43	4.5	122
KU1R 160 L4	KUOR 160 S4	1.5947	1.052	1250	2.78	4.36	98
KU1R 180 M4	KUOR 160 M4	1.2359	0.867	1072	2.19	3.52	79
KU1R 180 L4	KUOR 180 S4	0.7722	0.641	1081	2.09	3.61	68
KU1R 200 L4	KUOR 180 M4	0.5294	0.484	870	1.55	2.8	55
KU1R 225 S4	KUOR 200 M4	0.3194	0.327	694	1.33	2.53	48
KU1R 225 M4	KUOR 200 L4	0.2428	0.278	614	1.13	2.19	42
KU1R 250 M4	KUOR 225 M4	0.1925	0.188	511	0.98	1.86	39
KU1R 280 S4	KUOR 250 S4	0.1138	0.113	397	0.69	1.5	29
KU1R 280 M4	KUOR 250 M4	0.0919	0.094	352	0.59	1.3	25
KU1R 315 S4	KUOR 280 S4	0.0788	0.066	298	0.41	0.92	20
KU1R 315 M4	KUOR 280 M4	0.0656	0.056	275	0.36	0.83	18
KU1R 315 MX4	KUOR 315 S4	0.0569	0.052	266	0.31	0.77	16
KU1R 315 MY4	KUOR 315 M4	0.0416	0.028	245	0.22	0.58	14
KU1R 315 L4	KUOR 315 L4	0.03281	0.0233	356	0.1859	0.6094	12.28
KU1R 315 LX4	KUOR 315 LX4	0.02188	0.0172	267	0.1375	0.5781	9.08
KU2R 355 MY4		0.01228	0.0141	289	0.1889	0.3703	6.23
KU2R 355 M4		0.01031	0.0109	250	0.1438	0.1786	4.88
KU2R 355 MX4		0.00766	0.0086	234	0.1263	0.2731	4.7
KU2R 355 LY4		0.00647	0.0082	164	0.1048	0.2052	3.54
KU2R 355 L4		0.00678	0.0063	141	0.0922	0.1469	2.39

**Three-phase motors with squirrel-cage rotor
for converter-fed operation without filter up to 500 V**

with surface cooling, duty type S8, S9
for rated voltage, thermal class 155 (F), degree of protection IP 55, 50 Hz

Equivalent circuit data		Design point 500 V Δ, 50 Hz					
Type		R1 _w Ω	R2 _w Ω	R _F _e Ω	X1s Ω	X2s' Ω	X1 _h Ω
Synchronous speed 1000 rpm – 6-pole version							
KU1R 63 K6	KUOR 56 K6	559.22	467.81	50367	382.5	405	2259
KU1R 63 G6	KUOR 56 G6	408.75	388.13	41920	317.81	338.91	1917
KU1R 71 K6	KUOR 63 K6	202.03	171.09	21459	227.34	213.75	1008
KU1R 71 G6	KUOR 63 G6	175.78	156.09	21173	210	200.16	1134
KU1R 80 K6	KUOR 71 K6	175.78	109.69	18984	80.16	82.97	1106
KU1R 80 G6	KUOR 71 G6	106.41	78.75	13978	57.19	60	816
KU1R 90 S6	KUOR 80 K6	59.53	40.97	8484	39.98	47.81	572
KU1R 90 L6	KUOR 80 G6	40.27	30.89	6553	29.77	36.52	449
KU1R 100 L6	KUOR 90 L6	29.86	20.06	6108	23.77	27.7	373
KU1R 112 M6	KUOR 100 L6	21	14.16	5063	13.27	11.58	314
KU1R 132 S6T							
KU1R 132 S6	KUOR 112 M6	13.48	9.38	4214	12	10.95	276
KU1R 132 M6	KUOR 112 MX6	8.203	6.44	3000	8.19	7.66	192
KU1R 132 MX6	KUOR 132 S6	6.103	4.55	2633	7.69	9.88	179
KU1R 160 M6	KUOR 132 M6	3.653	3.5	2094	5.8	7.66	142
KU1R 160 L6	KUOR 160 S6	2.647	2.05	1830	4.05	5.36	128
KU1R 180 L6	KUOR 160 M6	1.466	1.3	1119	2.47	3.44	76
KU1R 200 L6	KUOR 180 S6	1.181	1.06	1111	2.59	3.19	89
KU1R 200 LX6	KUOR 180 M6	0.875	0.84	894	2.03	2.55	72
KU1R 225 M6	KUOR 200 M6	0.591	0.6	750	1.72	2.16	65
KU1R 250 M6	KUOR 225 M6	0.446	0.41	636	1.38	2.06	56
KU1R 280 S6	KUOR 250 S6	0.324	0.29	528	1.16	1.77	43
KU1R 280 M6	KUOR 250 M6	0.2341	0.222	423	0.891	1.391	34.2
KU1R 315 S6	KUOR 280 S6	0.1466	0.127	328	0.75	1.156	28.8
KU1R 315 M6	KUOR 280 M6	0.1159	0.098	275	0.578	0.938	23.6
KU1R 315 MX6	KUOR 315 S6	0.0919	0.078	216	0.469	0.75	18.4
KU1R 315 MY6	KUOR 315 M6	0.0744	0.064	239	0.422	0.719	17.7
KU1R 315 L6	KUOR 315 L6	0.0547	0.055	341	0.352	0.688	15.2
KU1R 315 LX6	KUOR 315 LX6	0.0365	0.039	197	0.248	0.531	9.7
KU2R 355 MY6		0.0267	0.026	258	0.286	0.533	8.5
KU2R 355 M6		0.0189	0.02	206	0.218	0.41	5.8
KU2R 355 MX6		0.0157	0.018	219	0.192	0.369	6.4
KU2R 355 LY6		0.0111	0.013	133	0.138	0.269	3.8
Synchronous speed 750 rpm – 8-pole version							
KU1R 71 K8	KUOR 63 K8	575.63	439.22	58228	305.63	416.72	1819
KU1R 71 G8	KUOR 63 G8	400.78	345.47	44564	239.53	326.72	1406
KU1R 80 K8	KUOR 71 K8	367.5	226.88	38306	156.56	185.63	1580
KU1R 80 G8	KUOR 71 G8	217.97	152.34	25641	104.06	124.69	1059
KU1R 90 S8	KUOR 80 K8	122.81	81.09	16931	74.06	102.19	750
KU1R 90 L8	KUOR 80 G8	82.97	62.81	13238	57.19	79.69	591
KU1R 100 L8	KUOR 90 L8	57.19	36.42	10463	40.45	53.91	427
KU1R 100 LX8	KUOR 100 S8	43.55	32.58	10730	30.14	27.09	433
KU1R 112 M8	KUOR 100 L8	28.73	20.53	8081	21.8	20.02	328
KU1R 132 S8T							
KU1R 132 S8	KUOR 112 M8	20.32	14.73	6481	18.98	18.47	267
KU1R 132 M8	KUOR 112 MX8	14.39	11.41	5208	14.5	14.39	214
KU1R 160 M8	KUOR 132 S8	9.76	7.88	4167	13.03	17.67	200
KU1R 160 MX8	KUOR 132 M8	6.19	5.78	3073	9.41	12.97	144
KU1R 160 L8	KUOR 160 S8	3.87	2.91	2367	5.55	8.11	105
KU1R 180 L8	KUOR 160 M8	2.384	2.14	1794	4.02	6.09	79
KU1R 200 L8	KUOR 180 S8	1.488	1.33	1242	3.28	4.22	62
	KUOR 180 M8						
KU1R 225 S8		1.181	1.2	1191	2.94	3.88	61
KU1R 225 M8	KUOR 200 M8	0.941	0.92	1075	2.66	3.58	62
KU1R 250 M8	KUOR 225 M8	0.547	0.52	683	1.69	2.66	39
KU1R 280 S8	KUOR 250 S8	0.416	0.36	664	1.45	2.41	34
KU1R 280 M8	KUOR 250 M8	0.252	0.27	484	1.05	1.77	25
KU1R 315 S8	KUOR 280 S8	0.2078	0.172	461	1.016	1.672	24.7
KU1R 315 M8	KUOR 280 M8	0.1444	0.131	367	0.781	1.281	19.5
KU1R 315 MX8	KUOR 315 S8	0.1269	0.109	298	0.656	1.078	15.9
KU1R 315 MY8	KUOR 315 M8	0.0831	0.078	264	0.516	0.938	13.1
KU1R 315 L8	KUOR 315 L8	0.0678	0.069	358	0.45	0.828	11.5
KU1R 315 LX8	KUOR 315 LX8	0.0446	0.048	250	0.311	0.578	7.5
KU2R 355 MY8		0.0309	0.028	258	0.384	0.476	7.7
KU2R 355 M8		0.023	0.024	250	0.317	0.389	5.8
KU2R 355 MX8		0.0183	0.021	197	0.256	0.319	5.4
KU2R 355 LY8		0.0133	0.017	156	0.204	0.255	3.9

Mechanical limit speeds

Where motors are operated above the rated speed, the limit values of the antifriction roller bearings, the strength of the rotating parts, critical rotor speeds and the circumferential speed of the fan must be observed.

The limit speeds specified in the table below may already require the implementation of additional measures such as special fans, special bearings or special balancing.

Type (IE1-)K21R/F	Synchronous speed at 50 Hz			
	3000 rpm	1500 rpm	1000 rpm	750 rpm
(IE1-)K21. 56/63	15000	12000	12000	-
(IE1-)K21. 71	14000	11000	11000	11000
(IE1-)K21. 80	13000	11000	10000	10000
(IE1-)K21. 90	11000	9000	9000	9000
(IE1-)K21. 100	10000	8000	8000	8000
(IE1-)K21. 100 LX	7000	6000	6000	6000
(IE1-)K21. 112	7000	6000	6000	6000
(IE1-)K21. 132T	7000	6000	6000	6000
(IE1-)K21. 132	7000	3600	2400	1800
(IE1-)K21. 160	6000	3600	2400	1800
(IE1-)K21. 180	6000	3000	2000	1500
(IE1-)K21. 200	5000	3000	2000	1500
(IE1-)K21. 225	5000	3000	2000	1500
(IE1-)K21. 250	4500	3000	2000	1500
(IE1-)K21. 280	4300	3000	2000	1500
(IE1-)K21. 315 S, M	3800	3000	2000	1500
(IE1-)K21. 315 MX	3600 ¹⁾	3000 ²⁾	3000	2000
(IE1-)K21. 315 MY, L, LX	3600 ¹⁾	3000 ²⁾	3000 ¹⁾	2600 ²⁾
(IE1-)K22. 355	3600 ¹⁾	3000 ²⁾	3000 ¹⁾	2600 ²⁾

Type (IE1-)K20R/F	Synchronous speed at 50 Hz			
	3000 rpm	1500 rpm	1000 rpm	750 rpm
(IE1-)K20. 56	15000	12000	12000	-
(IE1-)K20. 63	14000	11000	11000	11000
(IE1-)K20. 71	13000	11000	10000	10000
(IE1-)K20. 80	11000	9000	9000	9000
(IE1-)K20. 90	10000	8000	8000	8000
(IE1-)K20. 100	7000	6000	6000	6000
(IE1-)K20. 112	7000	3600	2400	1800
(IE1-)K20. 132	7000	3600	2400	1800
(IE1-)K20. 160	6000	3000	2000	1500
(IE1-)K20. 180	6000	3000	2000	1500
(IE1-)K20. 200	5000	3000	2000	1500
(IE1-)K20. 225	4500	3000	2000	1500
(IE1-)K20. 250	4300	3000	2000	1500
(IE1-)K20. 280	3800	3000	2000	1500
(IE1-)K20. 315 S	3600 ¹⁾	3000 ²⁾	3000	2000
(IE1-)K20. 315 M, L	3600 ¹⁾	3000 ²⁾	3000 ¹⁾	2600 ²⁾

Type IE2-W.1R/F, IE2-WE2R/F	Synchronous speed at 50 Hz			
	3000 rpm	1500 rpm	1000 rpm	750 rpm
IE2-WE1. 56,				
IE2-WE2. 56/63	15000	12000	12000	-
IE2-WE1. 63				
IE2-WE2. 71	14000	11000	11000	11000
IE2-WE1. 71				
IE2-WE2. 80	13000	11000	10000	10000
IE2-WE1. 80				
IE2-WE2. 90	11000	9000	9000	9000
IE2-WE1. 90				
IE2-WE2. 100	10000	8000	8000	8000
IE2-WE1. 100	7000	6000	6000	6000
IE2-WE1. 112	7000	6000	6000	6000
IE2-WE1. 132T	7000	6000	6000	6000
IE2-WE1. 132	7000	3600	2400	1800
IE2-WE2. 132				
IE2-WE.. 160	6000	3600	2400	1800
IE2-WE.. 180	6000	3000	2000	1500
IE2-WE.. 200	5000	3000	2000	1500
IE2-WE.. 225	5000	3000	2000	1500
IE2-WE.. 250	4500	3000	2000	1500
IE2-WE.. 280	4300	3000	2000	1500
IE2-WE.. 315 S, M	3800	3000	2000	1500
IE2-WE.. 315 MX	3600 ¹⁾	3000 ²⁾	3000	2000
IE2-WE.. 315 MY, L, LX	3600 ¹⁾	3000 ²⁾	3000 ¹⁾	2600 ²⁾
IE2-WE.. 355	3600 ¹⁾	3000 ²⁾	3000 ¹⁾	2600 ²⁾

Type IE3-W4.R/F	Synchronous speed at 50 Hz			
	3000 rpm	1500 rpm	1000 rpm	750 rpm
IE3-W41. 56,				
IE3-W42. 56/63	15000	12000	12000	-
IE3-W41. 63,	14000	11000	11000	11000
IE3-W42. 71				
IE3-W41. 71,	13000	11000	10000	10000
IE3-W42. 80				
IE3-W41. 80,	11000	9000	9000	9000
IE3-W42. 90				
IE3-W41. 90	10000	8000	8000	8000
IE3-W41. 100	7000	6000	6000	6000
IE3-W41. 112	7000	6000	6000	6000
IE3-W41. 132T	7000	6000	6000	6000
IE3-W41. 132,	7000	3600	2400	1800
IE3-W42. 132				
IE3-W4.. 160	6000	3600	2400	1800
IE3-W4.. 180	6000	3000	2000	1500
IE3-W4.. 200	5000	3000	2000	1500
IE3-W4.. 225	5000	3000	2000	1500
IE3-W4.. 250	4500	3000	2000	1500
IE3-W4.. 280	4300	3000	2000	1500
IE3-W4.. 315 S, M	3800	3000	2000	1500
IE3-W4.. 315 MX	3600 ¹⁾	3000 ²⁾	3000	2000
IE3-)W4.. 315 MY, L, LX	3600 ¹⁾	3000 ²⁾	3600 ¹⁾	3000 ²⁾
IE3-W4.. 355	3600 ¹⁾	3000 ²⁾	3600 ¹⁾	3000 ²⁾
IE3-W4.. 400	3600 ¹⁾	3000 ²⁾	3600 ¹⁾	3000 ²⁾

¹⁾ Light-duty bearing (D-end with deep-groove ball bearing)

²⁾ Heavy-duty bearing (D-end with cylindrical roller bearing)

The limit values apply accordingly for motors with forced ventilation, type of cooling IC 416, series (IE1-)K21F, (IE1) K20F and (IE2-)W.1R



VEM  MOTOR

Water-cooled motors

Contents

Product description	5/2
Overview of technical data	5/5
Motor selection data	
Series W4.B for Premium Efficiency IE3	5/6
Series WE.B for High Efficiency IE2	5/8
Bearings	
Identical to bearings of standard motors	
see Chapter 2	
Terminal boxes	
Identical to terminal boxes of standard motors	
see Chapter 2	
Dimensions	5/9

Product description

The demand for high-power motors requiring a minimum of installation space has increased significantly over the past few years, especially in mechanical engineering, and there above all from the manufacturers of injecting moulding machines, extruders, printing presses, paper machines, wire-drawing machines and machinery for the mining industry. For such applications, water cooling offers a very effective alternative for the cooling of asynchronous motors with high power density. The cooling effect is maintained also at slow running speeds. This is particularly beneficial where motors

are operated on a frequency converter, especially in applications with constant torque.

Further fields of application for water-cooled motors are heat recovery systems to utilise the waste heat of the motor, installation situations in which noise must be kept to a minimum, environments where heat losses must not be dissipated directly to the surroundings (e.g. air-conditioned rooms), extreme ambient conditions involving heavy dust, lint, dirt or moisture, and asynchronous generators for co-generation power plants.

Design versions

Our proven modular concept on the basis of robust, low-vibration grey cast iron components is also followed for the water-cooled motor versions. The motor housing is designed as a grey cast iron housing with integrated cooling tubes up to size 280 and as a double-walled welded steel construc-

tion from size 315. The terminal boxes, end shields, winding insulation, degree of protection and paint finish correspond to the standard design. The cooling principle provides for increased power outputs and optimum vibration damping from a compact motor design.

Shaft height	Material for			Foot mounting
	Housing	End shields	Feet	
225 – 280	Grey cast iron with integrated cooling tubes	Grey cast iron	Grey cast iron	Bolted
315 – 400	Welded steel construction	Grey cast iron	Grey cast iron	Welded

Degree of protection

The normal version of the motors meets the requirements for degree of protection IP 55. The protection rating can be raised to IP 56 where specified accordingly in the order, and motors with degree of protection IP 65 or higher can be supplied upon request.

In case of motors with a shaft end pointing upwards (IM V3/IM V36), the user must realise appropriate precautions to prevent the penetration of water along the shaft. On flange motors of construction Types IM V3/IM V36, a drain hole is provided as standard to prevent the collecting of liquid in the flange end.

Under normal circumstances, it is not necessary to implement special protection against the influences of the weather when motors are installed outdoors. If it is possible that the motors will be stored or operated at temperatures below freezing point, however, measures must be taken to prevent freezing of the cooling water inside the motor. At the same time, direct exposure to intensive sunlight must also be avoided, e.g. by way of a protective canopy.

Water cooling

With water cooling, the heat losses arising in the motor are dissipated via the cooling water. The inlet and outlet for the cooling water are located at the non-drive end (N-end) of the motor. A suitable corrosion inhibitor must always be added to the cooling water. If there is a risk of exposure to temperatures below freezing point, it is furthermore

necessary to add an antifreeze agent or to use a combined additive. The motors are intended for operation with a closed circuit. Open-circuit operation is possible as a special version from size 315. Where use of an open system is planned, however, prior consultation with VEM motors GmbH is imperative.

Output assignments

Size	Rated output [kW]							
	GR	EHL	GR	EHL	GR	EHL	GR	EHL
	2-pole		4-pole		6-pole		8-pole	
225 S	37	45	37	45	-	-	18,5	22
225 M	45	55	45	55	30	37	22	30
250 M	55	75	55	75	37	45	30	37
280 S	75	90	75	90	45	55	37	45
280 M	90	110	90	110	55	75	45	55
315 S	110	132	110	132	75	90	55	75
315 M	132	160	132	160	90	110	75	90
315 MX	160	200	160	200	110	132	90	110
315 MY	200	250	200	250	132	160	110	132
315 L	250	315	250	290	160	200	132	160
315 LX	315	355	315	355	200	240	160	200
355 M	355	400	355	400	250	315	200	250
355 MX	400	500	400	500	315	355	250	315
355 L	500	560	500	560	355	400	315	355
400 M	560	A	560	A	400	A	355	A
400 MX	630	A	630	A	450	A	400	A
400 L	710	A	710	A	500	A	450	A

GR... Basic series, EHL... Increased output
A... Upon request

Handling

If it is possible that the motors will be stored or operated at temperatures below freezing point, measures must be taken to prevent freezing of the cooling water inside the

motor. To this end, the cooling water can be drained before storage, or else an antifreeze agent can be added to permit operation at low temperatures.

Water supply to the motor, demands placed on cooling water

The cooling water must be of drinking water quality. The water pressure must not exceed 3.5 bar, and the maximum permissible cooling water inlet temperature is 30 °C. The following minimum requirements must be observed:

Baugröße	Cooling water flow rate [l/min]	Min. water pressure [bar]	Cooling water temperature rise [°C]
W.1B 225	10	0,5	6
W.1B 250	16	0,7	7
W.1B 280	18	1,0	9
W.1B 315	18	1,5	8
W.1B 355	20	2,0	10
W42B 355 MX	30	2,0	10–15
W42B 355 L	35	2,0	10–15
W42B 400	40	2,0	10–15

Product description

The inlet and outlet for the cooling water are located at the non-drive end of the motor housing. Suitable sealing provisions are to be realised at the connection points.

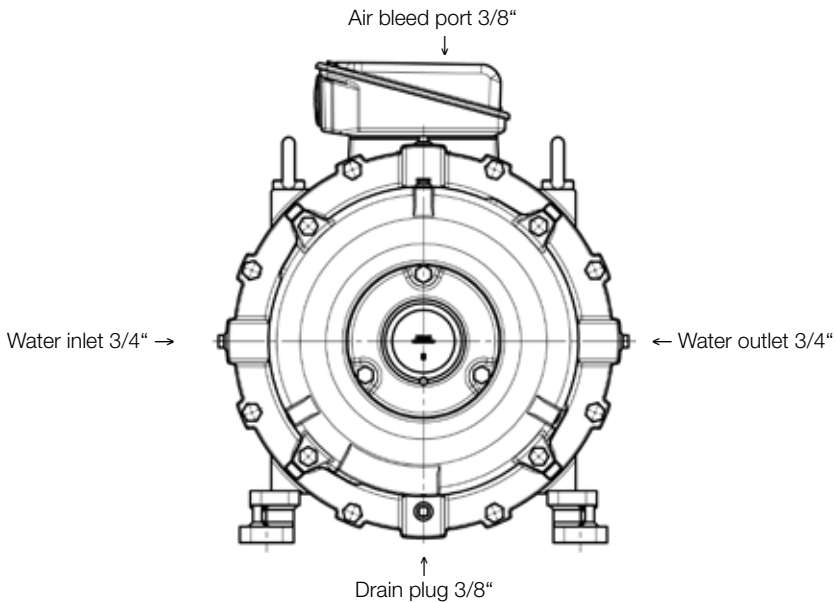

Size 225 bis 280

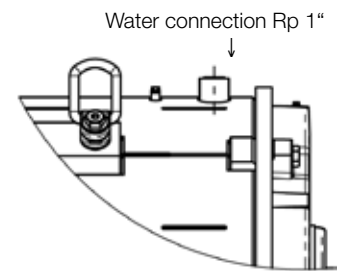

Size 315/355

The water supply must be guaranteed at all times while the motor is in operation. Operation without cooling water is not permissible.

On motors of sizes 225 to 280, there is additionally a 3/8" air bleed port at the top of the N-end, and a 3/8" water

drain plug at the lowest point. The air bleed port must be opened when the cooling circuit is filled. The motor is filled with cooling water until water starts to flow out at the open air bleed port.

Overview of technical data

The most important technical data are summarised in the following table. Further information can be taken from the catalogue section "Introduction" (chapter 1).

Product group	Squirrel-cage rotor, IEC/DIN
Rated output	30 to 710 kW
Sizes	225 to 400
Housing material	Grey cast iron
Rated torque	146 to 5400 Nm
Efficiency classification/ efficiency determination	IEC/EN 60034-30-1 / IEC/EN 60034-2-1, ≤ 1 kW direct measurement, > 1 kW residual loss method
Method of connection	Single-speed motors are designed in star-delta configuration as standard.
Stator winding insulation	Thermal class 155, optional 155 [F(B)], 180 to IEC/EN 60034-1
Degree of protection	IP 55 to IEC/EN 60034-5, optionally IP 56 or higher
Type of cooling	IC 71W (IC 31W upon request) to IEC/EN 60034-6
Coolant temperature/ installation altitude	max. 35 °C Altitude 1000 m above sea level
Rated voltage	Standard voltages to EN 60038 50 Hz: 230 V, 400 V, 500 V, 690 V 60 Hz: 275 V, 460 V, 480 V, 600 V Voltage ranges A and B to IEC/EN 60034-1 (Prior consultation necessary regarding 230 V, 50 Hz and 275 V, 60 Hz for motors from size 315)
Duty Types	S1, continuous duty, Short-time duty S2, 10/30/60 min Duty Type S3/S6, 25/40/60% c.d.f.
Types of construction	IM B3, IM B35, IM B5 and derived types to IEC/EN 60034-7
Paint finish	Normal finish "Moderate", colour RAL 7031, blue-grey Special finish "Worldwide", colour RAL 7031, blue-grey
Vibration severity grade	Grade "A" as standard for machines with no special vibration requirements
Shaft ends	to DIN 748 (IEC 60072), balanced with half-key
Limit speeds	Please refer to the section of "Limit speeds" in catalogue section "Motors for converter-fed operation", Chapter 4.
Bearing design	Please refer to the tables of "Bearing design data" in catalogue section „Standand motors“, Chapter 2.
Motor mass	Please refer to the technical selection lists.
Terminal boxes	Please refer to the section "Terminal boxes" in catalogue section „Standand motors“, Chapter 2.
Documentation	An operating and maintenance manual, a terminal plan and a safety data sheet are supplied with each motor.
Tolerances	Please refer to the section "Tolerances" in catalogue section "Introduction", Chapter 1.
Options	Please refer to the section "Overview of modifications" in catalogue section "Introduction", Chapter 1.

Motor selection data

Water-cooled three-phase motors with squirrel-cage rotor, Premium Efficiency IE3

Type of cooling IC 71W, duty cycle S1, continuous duty, thermal class 155,
Degree of protection IP 55, efficiency determination according to IEC/EN 60034-2-1

Motor selection data														Design point 400 V, 50 Hz				
Type	P_B	M_B	n_B	IE class	η_B			$\cos \varphi_B$	I_B	I_A/I_B	M_A/M_B	M_S/M_B	M_K/M_B	Max. cooling water flow rate	Min. cooling water pressure	Max. cooling water pressure	J	m
	kW	Nm	rpm		to IEC/IEC 60034-2-1	100 %	75 %											
Synchronous 3000 rpm – 2-pole version																		
IE3-W41B 315 S2	110	354	2970	IE3-	95.2	94.5	93.5	0.89	187	10.0	1.9	1.7	3.0	18.0	1.00	10	1.21	750
IE3-W41B 315 M2	132	423	2980	IE3-	95.4	95.0	94.5	0.89	224	10.0	2.0	1.8	3.0	18.0	1.00	10	1.44	815
IE3-W41B 315 MX2	160	513	2980	IE3-	95.7	95.7	95.0	0.9	268	8.5	2.3	1.7	2.6	18.0	1.50	10	2.37	1095
IE3-W41B 315 MY2	200	641	2980	IE3-	95.8	95.9	95.5	0.91	331	8.3	2.6	1.6	2.4	18.0	1.50	10	2.82	1200
IE3-W41B 315 L2	250	800	2985	IE3-	95.8	96.0	95.9	0.93	405	9.0	2.3	1.2	2.3	18.0	1.50	10	3.66	1460
IE3-W41B 315 LX2	315	1008	2985	IE3-	95.8	95.8	95.8	0.92	516	8.5	2.8	1.6	2.5	18.0	1.50	10	4.43	1700
IE3-W41B 355 M2	355	1136	2985	IE3-	96.0	96.0	96.0	0.92	580	7.7	1.9	1.5	3.8	20.0	2.00	10	4.20	2000
IE3-W41B 355 MX2	400	1278	2990	IE3-	95.8	95.8	95.3	0.91	665	8.5	1.5	1.2	2.5	30.0	2.00	10	5.50	2200
IE3-W41B 355 L2	500	1597	2990	IE3-	95.8	95.8	95.3	0.90	840	9.0	2.0	1.3	3.0	35.0	2.00	10	7.10	2445
IE3-W42B 400 M2	560	1790	2988	IE3-	95.8	95.8	95.3	0.88	965	7.2	1.5	1.4	2.5	40.0	2.00	10	8.44	3000
IE3-W42B 400 MX2	630	2014	2988	IE3-	95.8	95.8	95.3	0.89	1070	7.3	1.6	1.4	2.5	40.0	2.00	10	9.41	3200
IE3-W42B 400 L2	710	2269	2988	IE3-	95.8	95.8	95.3	0.90	1195	7.6	1.7	1.4	2.0	40.0	2.00	10	10.41	3450
Synchronous 1500 rpm – 4-pole version																		
IE3-W41B 315 S4	110	706	1487	IE3-	95.4	95.0	94.3	0.82	203	9.5	1.9	1.7	2.7	18.0	1.00	10	1.96	760
IE3-W41B 315 M4	132	849	1485	IE3-	95.6	95.4	95.0	0.83	240	9.0	2.2	1.9	2.7	18.0	1.00	10	2.27	850
IE3-W41B 315 MX4	160	1026	1490	IE3-	95.8	95.8	95.0	0.84	287	9.5	2.1	2.0	3.2	18.0	1.50	10	4.01	1120
IE3-W41B 315 MY4	200	1282	1490	IE3-	96.0	95.8	95.5	0.87	346	9.5	2.1	1.7	2.7	18.0	1.50	10	4.82	1250
IE3-W41B 315 L4	250	1602	1490	IE3-	96.2	96.2	96.0	0.87	431	9.4	2.2	1.8	2.7	18.0	1.50	10	5.93	1450
IE3-W41B 315 LX4	315	2019	1490	IE3-	96.0	96.0	96.0	0.87	544	9.5	2.3	1.7	2.9	18.0	1.50	10	6.82	1630
IE3-W41B 355 M 4	355	2271	1493	IE3-	96.2	96.2	95.5	0.87	612	8.1	1.3	1.0	2.7	20.0	2.00	10	7.90	2150
IE3-W41B 355 MX4	400	2564	1490	IE3-	96.0	96.0	95.5	0.84	719	8.0	1.7	1.4	2.4	30.0	2.00	10	9.50	2400
IE3-W41B 355 L4	500	3205	1490	IE3-	96.0	96.0	95.5	0.84	899	7.2	1.6	1.2	2.2	35.0	2.00	10	10.00	2500
IE3-W42B 400 M4	560	3582	1493	IE3-	96.0	96.0	95.5	0.84	1006	9.0	3.4	2.9	3.9	40.0	2.00	10	12.60	2900
IE3-W42B 400 MX4	630	4030	1493	IE3-	96.0	96.0	95.5	0.85	1119	9.0	3.6	3.0	4.2	40.0	2.00	10	14.33	3100
IE3-W42B 400 L4	710	4542	1493	IE3-	96.0	96.0	95.5	0.85	1261	9.0	3.9	3.1	4.2	40.0	2.00	10	16.29	3400
Synchronous 1000 rpm – 6-pole version																		
IE3-W41B 315 S6	75	723	990	IE3-	94.6	94.0	93.5	0.86	133	8.2	1.8	1.4	2.3	18.0	1.50	10	5.55	1060
IE3-W41B 315 M6	90	868	990	IE3-	94.9	94.0	93.0	0.86	159	8.5	2.2	1.7	2.8	18.0	1.50	10	6	1100
IE3-W41B 315 MX6	110	1061	990	IE3-	95.1	95.0	94.5	0.86	194	8.5	2.5	1.7	2.7	18.0	1.50	10	6.67	1210
IE3-W41B 315 L6	132	1267	995	IE3-	95.4	95.0	94.5	0.87	230	9.0	2.8	2.0	3.2	18.0	1.50	10	8.6	1550
IE3-W41B 355 M6	160	1536	995	IE3-	95.6	95.0	94.6	0.82	295	8.0	2.1	0.0	2.7	20.0	2.00	10	8.2	1850
IE3-W41B 355 MX6	200	1919	995	IE3-	95.8	95.0	94.0	0.85	355	9.0	2.1	0.0	2.9	20.0	2.00	10	12.10	2200
IE3-W41B 355 L6	250	2395	997	IE3-	95.8	95.5	95.0	0.84	448	8.8	2.2	1.5	2.8	35.0	2.00	10	14.00	2400
IE3-W41B 355 LX6	315	3023	995	IE3-	95.8	95.7	95.3	0.84	565	7.5	1.6	1.1	2.3	35.0	2.00	10	14.00	2400
IE3-W42B 400 MY6	355	3407	995	IE3-	95.8	95.5	94.5	0.85	632	8.0	2.0	1.6	2.6	40.0	2.00	10	16.54	2900
IE3-W42B 400 M6	400	3847	993	IE3-	95.8	95.5	94.5	0.87	696	7.0	1.8	1.5	2.3	40.0	2.00	10	16.54	2900
IE3-W42B 400 MX6	450	4327	993	IE3-	95.8	95.7	94.6	0.83	821	7.3	1.8	1.5	2.1	40.0	2.00	10	18.44	3100
IE3-W42B 400 L6	500	4808	993	IE3-	95.8	95.6	94.5	0.83	911	7.5	1.9	1.7	2.2	40.0	2.00	10	20.63	3400

Water-cooled three-phase motors with squirrel-cage rotor, Premium Efficiency IE3

Type of cooling IC 71W, duty cycle S1, continuous duty, thermal class 155,
Degree of protection IP 55, efficiency determination according to IEC/EN 60034-2-1

Motor selection data													Design point 400 V, 50 Hz					
Type	P_B	M_B	n_B	IE class	η_B			$\cos \varphi_B$	I_B	I_A/I_B	M_A/M_B	M_S/M_B	M_K/M_B	Max. cooling water flow rate	Min. cooling water pressure	Max. cooling water pressure	J	m
	kW	Nm	rpm		to IEC/IEC 60034-2-1	100 %	75 %											
Synchronous 750 rpm – 8-pole version																		
IE3-W41B 315 S8	55	707	743	IE3- 93.8	93.8	92.5	0.81	104	7.5	1.7	1.5	2.4	18.0	1.50	10	5.55	1060	
IE3-W41B 315 M8	75	968	740	IE3- 94.3	93.8	93.5	0.80	144	7.8	1.8	1.8	2.6	18.0	1.50	10	6	1100	
IE3-W41B 315 MX8	90	1154	745	IE3- 94.6	94.0	93.5	0.79	175	8.2	2.5	2.0	2.8	18.0	1.50	10	6.67	1250	
IE3-W41B 315 L8	110	1410	745	IE3- 94.9	94.0	93.5	0.8	210	8.3	2.2	1.9	2.8	18.0	1.50	10	10	1550	
IE3-W41B 355 M8	132	1692	745	IE3- 95.1	95.0	94.0	0.81	248	7.0	1.2	1.0	2.7	20.0	2.00	10	9.5	1850	
IE3-W41B 355 MX8	160	2054	744	IE3- 95.4	95.0	94.0	0.80	303	6.8	1.3	1.0	2.5	30.0	2.00	10	13.40	2200	
IE3-W41B 355 L8	200	2570	743	IE3- 95.6	95.5	94.0	0.77	393	6.5	1.6	1.0	2.7	35.0	2.00	10	15.80	2400	
IE3-W41B 355 LX8	250	3213	743	IE3- 95.6	95.4	93.8	0.78	487	6.4	2.5	1.9	2.5	35.0	2.00	10	15.80	2400	
IE3-W42B 400 MY8	315	4048	743	IE3- 95.6	95.5	94.5	0.78	611	6.4	2.5	1.9	2.5	40.0	2.00	10	17.94	2800	
IE3-W42B 400 M8	355	4550	745	IE3- 95.6	95.5	94.5	0.76	708	6.6	1.9	1.7	2.3	40.0	2.00	10	17.94	2900	
IE3-W42B 400 MX8	400	5134	744	IE3- 95.6	95.6	94.6	0.73	831	6.1	1.8	1.7	1.9	40.0	2.00	10	19.99	3100	
IE3-W42B 400 L8	450	5776	744	IE3- 95.6	95.6	94.6	0.72	947	6.4	2.0	1.7	2.0	40.0	2.00	10	22.34	3400	

Water-cooled three-phase motors with squirrel-cage rotor, High Efficiency, IE2



Type of cooling IC 71W, duty cycle S1, continuous duty, thermal class 155,
Degree of protection IP 55, efficiency determination according to IEC/EN 60034-2-1

Motor selection data													Design point 400 V, 50 Hz				
Type	P _B kW	M _B Nm	n _B rpm	IE class			cos φ _B	I _B 400 V A	I _A /I _B	M _A /M _B	M _S /M _B	M _K /M _B	Max. cooling water flow rate [l/min]	Min. cooling water pressure [bar]	Max. cooling water pressure [bar]	J kgm ²	m kg
				to IEC/IEC 60034-2-1	100 %	75 %											
Synchronous 3000 rpm – 2-pole version																	
IE2-WE1B 225 M2	45	146	2950	IE2- 92.9	92.2	91.2	0.87	80.5	6.9	1.7	1.1	2.7	10.0	0.5	3.5	0.220	295
IE2-WE1B 250 M2	55	178	2955	IE2- 93.5	93.7	93.2	0.89	95.5	8.2	2.3	1.9	2.8	16.0	0.7	3.5	0.375	385
IE2-WE1B 280 S2	75	241	2970	IE2- 94.1	94.0	91.5	0.90	128	7.9	2.1	1.7	3.0	18.0	1.0	3.5	0.65	500
IE2-WE1B 280 M2	90	289	2970	IE2- 94.4	94.1	91.9	0.91	151	7.7	2.0	1.7	2.8	18.0	1.0	3.5	0.68	550
IE2-WE1B 315 S2	110	353	2975	IE2- 94.5	94.3	93.3	0.89	189	8.0	1.3	1.2	2.4	18.0	1.5	10.0	1.21	730
IE2-WE1B 315 M2	132	424	2975	IE2- 95.0	94.8	94.5	0.89	225	9.2	1.4	1.2	2.4	18.0	1.5	10.0	1.44	820
IE2-WE1B 315 MX2	160	514	2973	IE2- 94.8	94.8	94.8	0.89	274	8.2	1.3	1.3	2.4	18.0	1.5	10.0	1.76	955
IE2-WE1B 315 MY2	200	640	2983	IE2- 95.4	95.0	94.3	0.88	344	9.4	2.8	2.0	3.0	18.0	1.5	10.0	2.82	1200
IE2-WE1B 315 L2	250	800	2984	IE2- 95.4	95.4	95.4	0.92	411	9.0	2.3	1.2	2.3	18.0	1.5	10.0	3.66	1450
IE2-WE1B 315 LX2	315	1008	2985	IE2- 95.4	95.4	95.0	0.92	518	8.5	2.8	1.6	2.5	18.0	1.5	10.0	4.43	1700
IE2-WE2B 355 M2	355	1136	2985	IE2- 95.5	95.5	95.5	0.92	583	7.7	1.9	1.5	3.8	20.0	2.0	10.0	4.20	2000
IE2-WE2B 355 MX2	400	1278	2990	IE2- 95.5	95.5	95.5	0.91	664	9.4	1.8	1.0	3.0	30.0	2.0	10.0	4.50	2200
IE2-WE2B 355 LY2	450	1440	2985	IE2- 95.5	95.5	95.5	0.92	739	7.0	1.3	0.9	2.4	35.0	2.0	10.0	7.10	2400
IE2-WE2B 355 L2	500	1597	2990	IE2- 95.5	95.5	95.5	0.92	821	8.5	1.5	1.2	2.5	35.0	2.0	10.0	7.10	2400
Synchronous 1500 rpm – 4-pole version																	
IE2-WE1B 225 MY4	30	194	1480	IE2- 92.3	91.3	88.2	0.80	58.5	7.3	2.1	1.7	2.9	10.0	0.5	3.5	0.275	277
IE2-WE1B 225 M4	37	240	1475	IE2- 92.7	91.8	90.7	0.84	68.5	7.4	2.2	1.7	2.7	10.0	0.5	3.5	0.313	313
IE2-WE1B 225 MX4	45	290	1483	IE2- 93.1	93.0	91.1	0.84	83	7.9	2.3	1.9	2.4	10.0	0.5	3.5	0.525	390
IE2-WE1B 250 M4	55	354	1485	IE2- 94.0	94.1	92.5	0.84	101	8.0	2.0	1.7	2.3	16.0	0.7	3.5	0.95	535
IE2-WE1B 280 S4	75	482	1485	IE2- 94.2	94.4	92.1	0.84	137	7.2	1.8	1.6	2.1	18.0	1.0	3.5	0.95	550
IE2-WE1B 280 M4	90	580	1483	IE2- 94.3	94.5	94.0	0.84	164	7.6	1.8	1.6	2.3	18.0	1.0	3.5	1.10	610
IE2-WE1B 315 S4	110	707	1485	IE2- 94.8	94.8	94.0	0.82	204	8.5	1.8	1.5	2.7	18.0	1.5	10.0	1.96	760
IE2-WE1B 315 M4	132	849	1484	IE2- 95.0	95.0	94.5	0.83	242	8.2	1.8	1.6	2.3	18.0	1.5	10.0	2.27	850
IE2-WE1B 315 MX4	160	1031	1482	IE2- 95.0	95.0	94.5	0.84	289	7.4	1.6	1.4	2.2	18.0	1.5	10.0	2.73	975
IE2-WE1B 315 MY4	200	1282	1490	IE2- 95.1	95.1	94.5	0.87	349	8.5	1.8	1.6	2.5	18.0	1.5	10.0	4.82	1270
IE2-WE1B 315 L4	250	1602	1490	IE2- 95.4	95.4	95.3	0.88	430	9.0	2.2	1.5	2.7	18.0	1.5	10.0	5.93	1450
IE2-WE1B 315 LX4	315	2019	1490	IE2- 95.4	95.4	95.0	0.88	542	9.0	2.4	1.6	2.6	18.0	1.5	10.0	6.82	1630
IE2-WE2B 355 M4	355	2271	1493	IE2- 95.5	95.5	95.0	0.87	617	8.0	1.3	1.0	2.7	20.0	2.0	10.0	7.90	2150
IE2-WE2B 355 MX4	400	2557	1494	IE2- 95.5	95.5	95.5	0.88	687	8.5	1.3	1.0	3.0	30.0	2.0	10.0	9.50	2400
IE2-WE2B 355 LY4	450	2873	1496	IE2- 95.5	95.5	95.5	0.86	791	8.5	1.4	0.8	2.9	35.0	2.0	10.0	10.00	2500
IE2-WE2B 355 L4	500	3198	1493	IE2- 95.5	95.5	95.5	0.84	900	8.0	1.2	0.9	3.0	35.0	2.0	10.0	10.00	2500
Synchronous 1000 rpm – 6-pole version																	
IE2-WE1B 200 MY6	22	214	980	IE2- 90.9	90.2	88.5	0.86	40.5	6.4	2.2	1.8	2.7	10.0	0.5	3.5	0.443	272
IE2-WE1B 225 M6	30	291	985	IE2- 92.0	91.5	90.0	0.86	54.5	7.3	2.5	2.2	2.9	10.0	0.5	3.5	0.825	365
IE2-WE1B 250 M6	37	359	985	IE2- 92.2	91.7	90.7	0.85	68	6.4	2.7	1.8	2.4	16.0	0.7	3.5	1.28	480
IE2-WE1B 280 S6	45	437	983	IE2- 93.0	92.7	92.4	0.87	80.5	6.5	2.2	1.7	2.4	18.0	1.0	10.0	1.48	560
IE2-WE1B 280 M6	55	531	990	IE2- 93.6	93.5	93.0	0.85	100	7.6	2.0	1.5	2.5	18.0	1.0	10.0	2.63	710
IE2-WE1B 315 S6	75	723	990	IE2- 93.9	93.7	93.5	0.87	133	7.8	1.9	1.5	2.5	18.0	1.5	10.0	3.33	804
IE2-WE1B 315 M6	90	868	990	IE2- 94.0	94.0	93.5	0.88	157	7.5	1.8	1.5	2.5	18.0	1.5	10.0	3.60	865
IE2-WE1B 315 MX6	110	1061	990	IE2- 94.3	94.3	94.0	0.87	194	7.5	1.8	1.4	2.3	18.0	1.5	10.0	6.67	1210
IE2-WE1B 315 MY6	132	1273	990	IE2- 94.6	94.3	94.0	0.87	231	7.5	1.9	1.4	2.2	18.0	1.5	10.0	6.67	1250
IE2-WE1B 315 L6	160	1543	990	IE2- 94.8	94.5	93.5	0.88	277	7.5	2.0	1.5	2.4	18.0	1.5	10.0	8.60	1430
IE2-WE1B 315 LX6	200	1929	990	IE2- 95.0	95.0	94.5	0.86	353	7.0	1.9	1.5	2.2	18.0	1.5	10.0	8.60	1460
IE2-WE2B 355 M6	250	2402	994	IE2- 95.0	95.0	94.7	0.84	452	7.0	1.5	1.2	2.2	20.0	2.0	10.0	8.20	1850
IE2-WE2B 355 MX6	315	3023	995	IE2- 95.2	95.2	95.2	0.86	555	7.0	1.3	1.1	2.2	30.0	2.0	10.0	12.1	2200
IE2-WE2B 355 LY6	355	3407	995	IE2- 95.0	95.0	94.0	0.77	700	7.5	1.8	1.5	2.6	35.0	2.0	10.0	14.0	2400

Water-cooled three-phase motors with squirrel-cage rotor, High Efficiency, IE2

Type of cooling IC 71W, duty cycle S1, continuous duty, thermal class 155,
Degree of protection IP 55, efficiency determination according to IEC/EN 60034-2-1

Motor selection data													Design point 400 V, 50 Hz					
Type	P _B kW	M _B Nm	n _B rpm	IE class	η _B to IEC/IEC 60034-2-1			cos φ _B -	I _B 400 V A	I _A /I _B -	M _A /M _B -	M _S /M _B -	M _K /M _B -	Max. cooling water flow rate [l/min]	Min. cooling water pressure [bar]	Max. cooling water pressure [bar]	J kgm ²	m kg
					100 %	75 %	50 %											
Synchronous 750 rpm – 8-pole version																		
IE2-WE1B 225 S8	18.5	242	730	IE2- 89.6	89.4	87.2	0.78	38	5.4	2.1	2.0	2.8	10.0	0.5	3.5	0.440	265	
IE2-WE1B 225 M8	22	287	733	IE2- 90.6	89.4	89.9	0.78	45	5.6	2.2	1.8	2.6	10.0	0.5	3.5	0.825	380	
IE2-WE1B 250 M8	30	389	737	IE2- 91.5	91.2	88.3	0.78	60.5	5.5	2.2	1.8	2.5	16.0	0.7	3.5	1.350	480	
IE2-WE1B 280 S8	37	480	736	IE2- 91.6	91.1	88.6	0.79	73.5	5.4	2.0	1.7	2.3	18.0	1.0	3.5	1.55	550	
IE2-WE1B 280 M8	45	581	740	IE2- 92.7	92.7	92.0	0.79	88.5	6.7	1.8	1.5	2.5	18.0	1.0	10.0	2.63	690	
IE2-WE1B 315 S8	55	710	740	IE2- 93.0	93.0	92.5	0.80	107	6.0	1.8	1.5	2.2	18.0	1.5	10.0	3.33	800	
IE2-WE1B 315 M8	75	968	740	IE2- 93.5	93.5	93.0	0.81	143	6.0	1.8	1.5	2.1	18.0	1.5	10.0	3.6	880	
IE2-WE1B 315 MX8	90	1161	740	IE2- 92.1	91.6	90.1	0.81	174	6.0	1.9	0.0	2.2	18.0	1.5	10.0	6	1050	
IE2-WE1B 315 MY8	110	1420	740	IE2- 93.8	93.3	91.2	0.81	209	6.5	2.1	0.0	2.4	18.0	1.5	10.0	6.76	1250	
IE2-WE1B 315 L8	132	1704	740	IE2- 94.4	94.0	93.5	0.83	243	7.5	2.2	1.8	2.5	18.0	1.5	10.0	8.71	1430	
IE2-WE1B 315 LX8	160	2065	740	IE2- 94.2	94.2	93.8	0.80	306	7.2	2.2	1.8	2.5	18.0	1.5	10.0	8.71	1430	
IE2-WE2B 355 M8	200	2571	743	IE2- 94.7	94.1	91.5	0.77	396	0.0	0.0	0.0	0.0	20.0	2.0	10.0	9.5	1850	
IE2-WE2B 355 MX8	250	3205	745	IE2- 95.8	95.8	95.5	0.83	454	7.0	1.2	1.0	2.6	30.0	2.0	10.0	13.4	2200	
IE2-WE2B 355 LY8	280	3599	743	IE2- 94.8	94.1	91.5	0.78	547	0.0	0.0	0.0	0.0	35.0	2.0	10.0	15.8	2400	

Dimensions

Flange dimensions

Flanges with through-holes

Flange Type to DIN EN 50 347	Flange Type to DIN 42948	LA c1	M e1	N b1	P a1	S s1	T f1
FF 400	A 450	16	400	350	450	18	5
FF 500	A 550	18	500	450	550	18	5
FF 600	A 660	22	600	550	660	22	6
FF 740	A 800	25	740	680	800	22	6

DIN EN 50 347 assigns FF flanges with through-holes and FT flanges with threaded holes to the different sizes. The flange designations A and C defined in DIN 42948 also remain valid.

Flange assignments which deviate from the standard are specified in the flange assignment tables of this catalogue.

For tolerances for the dimension N(b1), refer to the corresponding dimension tables

LA (c1) Depth of engagement

Water-cooled three-phase motors with squirrel-cage rotor, Premium Efficiency IE3

Type of cooling IC 71W, duty cycle S1, continuous duty,
Thermal class 155, degree of protection IP 55
Size 315

Type of construction IM B3 [IM 1001]

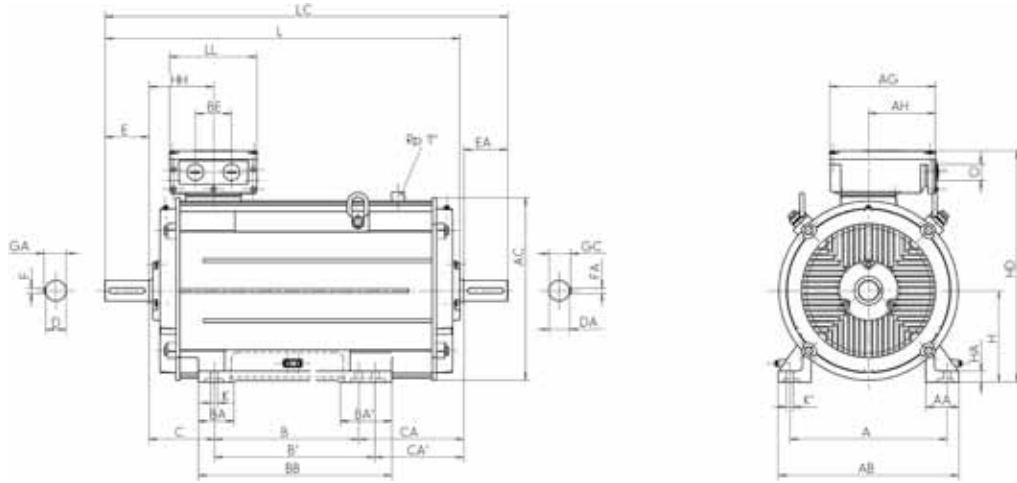

Type designation	A	AA	AB	AC	B	BA	BA'	BB	C	CA	D	DA	DB ¹⁾	E	EA	F	FA
	b	n	f	g	a	m	m1	e	w1	w2	d	d1		l	l1	u	u1
IE3-W41B 315 S2	508	126	590	550	406	120	-	503	216	126	65	65	M20	140	140	18	18
IE3-W41B 315 S4	508	126	590	550	406	120	-	503	216	126	80	70	M20	170	140	22	20
IE3-W41B 315 S8	508	126	590	550	406	120	-	503	216	126	80	70	M20	170	140	22	20
IE3-W41B 315 M2	508	126	590	550	457	120	-	554	216	130	65	65	M20	140	140	18	18
IE3-W41B 315 M4	508	126	590	550	457	120	-	554	216	130	80	70	M20	170	140	22	20
IE3-W41B 315 S6	508	110	590	610	406	120	150	554	216	259	80	70	M20	170	140	22	20
IE3-W41B 315 M6, 8	508	110	590	610	457	120	150	554	216	208	80	70	M20	170	140	22	20
IE3-W41B 315 MX2	508	110	590	610	457	120	150	554	216	208	65	65	M20	140	140	18	18
IE3-W41B 315 MX4	508	110	590	610	457	120	150	554	216	208	80	70	M20	170	140	22	20
IE3-W41B 315 MX6, 8	508	110	590	610	457	120	150	554	216	128	80	70	M20	170	140	22	20
IE3-W41B 315 MX10, 12	508	110	590	610	457	120	150	554	216	128	80	70	M20	170	140	22	20
IE3-W41B 315 MY2	508	110	590	610	457	120	-	573	216	307	65	65	M20	140	140	18	18
IE3-W41B 315 MY4, 6, 8	508	110	590	610	457	120	-	573	216	307	80	70	M20	170	140	22	20
IE3-W41B 315 L2	508	110	590	610	508	120	-	624	216	376	65	65	M20	140	140	18	18
IE3-W41B 315 L4, 6, 8	508	110	590	610	508	120	-	624	216	376	80	70	M20	170	140	22	20
IE3-W41B 315 LX2	508	110	590	610	508	120	-	624	216	496	65	65	M20	140	140	18	18
IE3-W41B 315 LX4	508	110	590	610	508	120	-	624	216	496	80	70	M20	170	140	22	20
IE3-W41B 315 LX6, 8	508	110	590	610	508	120	-	624	216	376	80	70	M20	170	140	22	20

Type designation	GA	GC	H	HA	HD	HH	K	K'	L	LC	TB Type	AG	LL	AH	O
	t	t1	h	c	p	A	s	s'	k	k1				-	
IE3-W41B 315 S2	69	69	315	44	731	211	28	35	879	1026	200 A	282	242	-	M63 x 1.5
IE3-W41B 315 S4	85	74.5	315	44	731	211	28	35	909	1056	200 A	282	242	-	M63 x 1.5
IE3-W41B 315 S8	85	74.5	315	44	731	211	28	35	964	1111	200 A	282	242	-	M63 x 1.5
IE3-W41B 315 M2	69	69	315	44	731	211	28	35	934	1081	200 A	282	242	-	M63 x 1.5
IE3-W41B 315 M4	85	74.5	315	44	731	211	28	35	964	1111	200 A	282	242	-	M63 x 1.5
IE3-W41B 315 S6	85	74.5	315	44	809	230	28	35	1044	1191	400 A-SB	415	340	265	M63 x 1.5
IE3-W41B 315 M6, 8	85	74.5	315	44	809	230	28	35	1146	1290	400 A-SB	415	340	265	M63 x 1.5
IE3-W41B 315 MX2	69	69	315	44	809	230	28	35	1014	1161	400 A-SB	415	340	265	M63 x 1.5
IE3-W41B 315 MX4	85	74.5	315	44	809	230	28	35	1044	1191	400 A-SB	415	340	265	M63 x 1.5
IE3-W41B 315 MX6, 8	85	74.5	315	44	809	230	28	35	964	1111	400 A-SB	415	340	265	M63 x 1.5
IE3-W41B 315 MX10, 12	85	74.5	315	44	809	230	28	35	964	1111	400 A-SB	415	340	265	M63 x 1.5
IE3-W41B 315 MY2	69	69	315	44	809	230	28	35	1116	1260	400 A-SB	415	340	265	M63 x 1.5
IE3-W41B 315 MY4, 6, 8	85	74.5	315	44	809	230	28	35	1146	1290	400 A-SB	415	340	265	M63 x 1.5
IE3-W41B 315 L2	69	69	315	44	809	230	28	35	1236	1380	400 A-SB	415	340	265	M63 x 1.5
IE3-W41B 315 L4, 6, 8	85	74.5	315	44	809	230	28	35	1266	1410	400 A-SB	415	340	265	M63 x 1.5
IE3-W41B 315 LX2	69	69	315	44	809	230	28	35	1356	1500	400 A-SB	415	340	265	M63 x 1.5
IE3-W41B 315 LX4	85	74.5	315	44	809	230	28	35	1386	1530	400 A-SB	415	340	265	M63 x 1.5
IE3-W41B 315 LX6, 8	85	74.5	315	44	809	230	28	35	1266	1410	400 A-SB	415	340	265	M63 x 1.5

¹⁾ Centre holes to DIN 332-DS
Subject to changes in the course of further development.

Water-cooled three-phase motors with squirrel-cage rotor, Premium Efficiency IE3

Type of cooling IC 71W, duty cycle S1, continuous duty,
Thermal class 155, degree of protection IP 55
Size 315

Type of construction IM B35 [IM 2001]

Flange dimensions see page 5/9

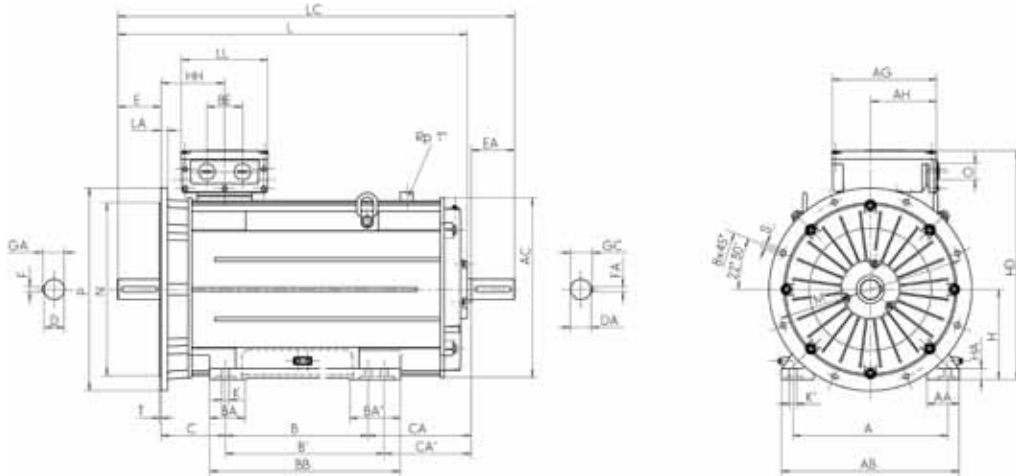

Type designation	Flange size	A	AA	AB	AC	B	BA	BA'	BB	C	CA	D	DA	DB ¹⁾	E	EA	F	FA
		b	n	f	g	a	m	m1	e	w1	w2	d	d1		l	l1	u	u1
IE3-W41B 315 S2	FF 600	508	126	590	550	406	120	-	503	216	126	65	65	M20	140	140	18	18
IE3-W41B 315 S4	FF 600	508	126	590	550	406	120	-	503	216	126	80	70	M20	170	140	22	20
IE3-W41B 315 S8	FF 600	508	126	590	550	406	120	-	503	216	126	80	70	M20	170	140	22	20
IE3-W41B 315 M2	FF 600	508	126	590	550	457	120	-	554	216	130	65	65	M20	140	140	18	18
IE3-W41B 315 M4	FF 600	508	126	590	550	457	120	-	554	216	130	80	70	M20	170	140	22	20
IE3-W41B 315 S6	FF 600	508	110	590	610	406	120	150	554	216	259	80	70	M20	170	140	22	20
IE3-W41B 315 M6, 8	FF 600	508	110	590	610	457	120	150	554	216	208	80	70	M20	170	140	22	20
IE3-W41B 315 MX2	FF 600	508	110	590	610	457	120	150	554	216	208	65	65	M20	140	140	18	18
IE3-W41B 315 MX4	FF 600	508	110	590	610	457	120	150	554	216	208	80	70	M20	170	140	22	20
IE3-W41B 315 MX6, 8	FF 600	508	110	590	610	457	120	150	554	216	128	80	70	M20	170	140	22	20
IE3-W41B 315 MX10, 12	FF 600	508	110	590	610	457	120	150	554	216	128	80	70	M20	170	140	22	20
IE3-W41B 315 MY2	FF 600	508	110	590	610	457	120	-	573	216	307	65	65	M20	140	140	18	18
IE3-W41B 315 MY4, 6, 8	FF 600	508	110	590	610	457	120	-	573	216	307	80	70	M20	170	140	22	20
IE3-W41B 315 L2	FF 600	508	110	590	610	508	120	-	624	216	376	65	65	M20	140	140	18	18
IE3-W41B 315 L4, 6, 8	FF 600	508	110	590	610	508	120	-	624	216	376	80	70	M20	170	140	22	20
IE3-W41B 315 LX2	FF 600	508	110	590	610	508	120	-	624	216	496	65	65	M20	140	140	18	18
IE3-W41B 315 LX4	FF 600	508	110	590	610	508	120	-	624	216	496	80	70	M20	170	140	22	20
IE3-W41B 315 LX6, 8	FF 600	508	110	590	610	508	120	-	624	216	376	80	70	M20	170	140	22	20

Type designation	GA	GC	H	HA	HD	HH	K	K'	L	LC	TB Type	AG	LL	AH	O
	t	t1	h	c	p	A	s	s'	k	k1					
IE3-W41B 315 S2	69	69	315	44	731	211	28	35	879	1026	200 A	282	242	-	M63 x 1.5
IE3-W41B 315 S4	85	74.5	315	44	731	211	28	35	909	1056	200 A	282	242	-	M63 x 1.5
IE3-W41B 315 S8	69	69	315	44	731	211	28	35	964	1111	200 A	282	242	-	M63 x 1.5
IE3-W41B 315 M2	85	74.5	315	44	731	211	28	35	934	1081	200 A	282	242	-	M63 x 1.5
IE3-W41B 315 M4	85	74.5	315	44	731	211	28	35	964	1111	200 A	282	242	-	M63 x 1.5
IE3-W41B 315 S6	85	74.5	315	44	809	230	28	35	1044	1191	400 A-SB	415	340	265	M63 x 1.5
IE3-W41B 315 M6, 8	85	74.5	315	44	809	230	28	35	1146	1290	400 A-SB	415	340	265	M63 x 1.5
IE3-W41B 315 MX2	69	69	315	44	809	230	28	35	1014	1161	400 A-SB	415	340	265	M63 x 1.5
IE3-W41B 315 MX4	85	74.5	315	44	809	230	28	35	1044	1191	400 A-SB	415	340	265	M63 x 1.5
IE3-W41B 315 MX6, 8	85	74.5	315	44	809	230	28	35	964	1111	400 A-SB	415	340	265	M63 x 1.5
IE3-W41B 315 MX10, 12	85	74.5	315	44	809	230	28	35	964	1111	400 A-SB	415	340	265	M63 x 1.5
IE3-W41B 315 MY2	69	69	315	44	809	230	28	35	1116	1260	400 A-SB	415	340	265	M63 x 1.5
IE3-W41B 315 MY4, 6, 8	85	74.5	315	44	809	230	28	35	1146	1290	400 A-SB	415	340	265	M63 x 1.5
IE3-W41B 315 L2	69	69	315	44	809	230	28	35	1236	1380	400 A-SB	415	340	265	M63 x 1.5
IE3-W41B 315 L4, 6, 8	85	74.5	315	44	809	230	28	35	1266	1410	400 A-SB	415	340	265	M63 x 1.5
IE3-W41B 315 LX2	69	69	315	44	809	230	28	35	1356	1500	400 A-SB	415	340	265	M63 x 1.5
IE3-W41B 315 LX4	85	74.5	315	44	809	230	28	35	1386	1530	400 A-SB	415	340	265	M63 x 1.5
IE3-W41B 315 LX6, 8	85	74.5	315	44	809	230	28	35	1266	1410	400 A-SB	415	340	265	M63 x 1.5

¹⁾ Centre holes to DIN 332-DS
Subject to changes in the course of further development.

Water-cooled three-phase motors with squirrel-cage rotor, Premium Efficiency IE3

Type of cooling IC 71W, duty cycle S1, continuous duty,
 Thermal class 155, degree of protection IP 55
 Size 315

Type of construction IM B5 [IM 3001] to Type of construction 315 MY
Type of construction IM V1 [IM 3011]

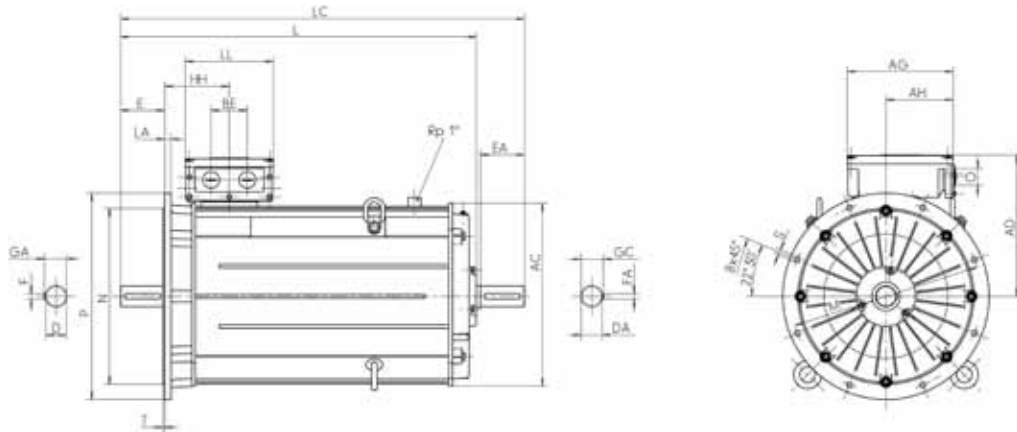

Type designation	Flange size	AC	AD	D	DA	DB ¹⁾	E	EA	F	FA	GA	GC	H	HH	L	LC	TB Type	AG	LL	AH	O
		g	g1	d	d1		l	l1	u	u1	t	t1	h	A	k	k1		x	z	-	r
IE3-W41B 315 S2	FF 600	550	416	65	65	M20	140	140	18	18	69	69	315	211	879	1026	200 A	282	242	-	M63 x 1.5
IE3-W41B 315 S4	FF 600	550	416	80	70	M20	170	140	22	20	85	74.5	315	211	909	1056	200 A	282	242	-	M63 x 1.5
IE3-W41B 315 S8	FF 600	550	416	65	65	M20	140	140	18	18	69	69	315	211	964	1111	200 A	282	242	-	M63 x 1.5
IE3-W41B 315 M2	FF 600	550	416	80	70	M20	170	140	22	20	85	74.5	315	211	934	1081	200 A	282	242	-	M63 x 1.5
IE3-W41B 315 M4	FF 600	550	416	80	70	M20	170	140	22	20	85	74.5	315	211	964	1111	200 A	282	242	-	M63 x 1.5
IE3-W41B 315 S6	FF 600	610	494	80	70	M20	170	140	22	20	85	74.5	315	230	1044	1191	400 A-SB	415	340	265	M63 x 1.5
IE3-W41B 315 M6, 8	FF 600	610	494	80	70	M20	170	140	22	20	85	74.5	315	230	1146	1290	400 A-SB	415	340	265	M63 x 1.5
IE3-W41B 315 MX2	FF 600	610	494	65	65	M20	140	140	18	18	69	69	315	230	1014	1161	400 A-SB	415	340	265	M63 x 1.5
IE3-W41B 315 MX4	FF 600	610	494	80	70	M20	170	140	22	20	85	74.5	315	230	1044	1191	400 A-SB	415	340	265	M63 x 1.5
IE3-W41B 315 MX6, 8	FF 600	610	494	80	70	M20	170	140	22	20	85	74.5	315	230	964	1111	400 A-SB	415	340	265	M63 x 1.5
IE3-W41B 315 MX10, 12	FF 600	610	494	80	70	M20	170	140	22	20	85	74.5	315	230	964	1111	400 A-SB	415	340	265	M63 x 1.5
IE3-W41B 315 MY2	FF 600	610	494	65	65	M20	140	140	18	18	69	69	315	230	1116	1260	400 A-SB	415	340	265	M63 x 1.5
IE3-W41B 315 MY4, 6, 8	FF 600	610	494	80	70	M20	170	140	22	20	85	74.5	315	230	1146	1290	400 A-SB	415	340	265	M63 x 1.5
IE3-W41B 315 L2	FF 600	610	494	65	65	M20	140	140	18	18	69	69	315	230	1236	1380	400 A-SB	415	340	265	M63 x 1.5
IE3-W41B 315 L4, 6, 8	FF 600	610	494	80	70	M20	170	140	22	20	85	74.5	315	230	1266	1410	400 A-SB	415	340	265	M63 x 1.5
IE3-W41B 315 LX2	FF 600	610	494	65	65	M20	140	140	18	18	69	69	315	230	1356	1500	400 A-SB	415	340	265	M63 x 1.5
IE3-W41B 315 LX4	FF 600	610	494	80	70	M20	170	140	22	20	85	74.5	315	230	1386	1530	400 A-SB	415	340	265	M63 x 1.5
IE3-W41B 315 LX6, 8	FF 600	610	494	80	70	M20	170	140	22	20	85	74.5	315	230	1266	1410	400 A-SB	415	340	265	M63 x 1.5

¹⁾ Centre holes to DIN 332-DS
 Subject to changes in the course of further development.

Water-cooled three-phase motors with squirrel-cage rotor, Premium Efficiency IE3

Type of cooling IC 71W, duty cycle S1, continuous duty,
Thermal class 155, degree of protection IP 55
Size 355

Type of construction IM B3 [IM 1001]

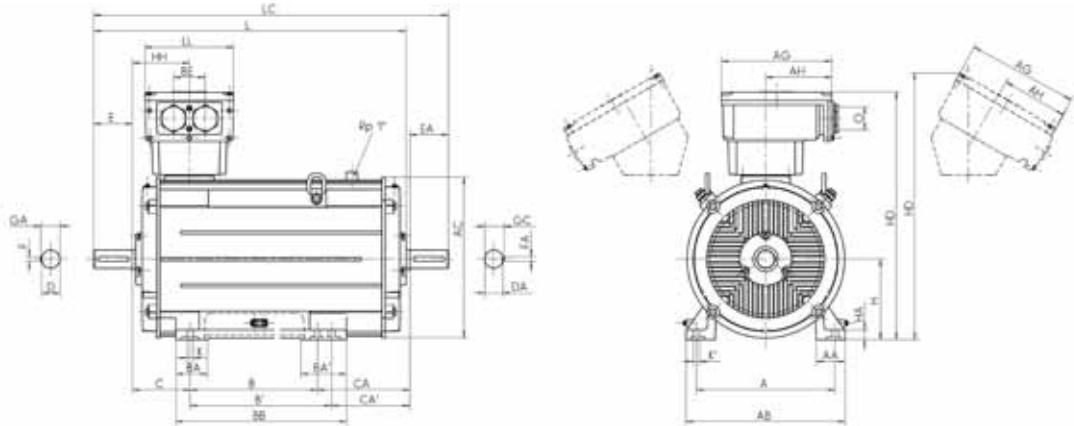

Type designation	A	AA	AB	AC	B	BA	BA'	BB	C	CA	D	DA	DB ¹⁾	E	EA	F	FA
	b	n	f	g	a	m	m1	e	w1	w2	d	d1		l	l1	u	u1
IE3-W41B 355 MY2, M2	610	130	700	715	560	140	200	750	254	398	80	80	M20	170	170	22	22
IE3-W41B 355 MY4, 6, 8	610	130	700	715	560	140	200	750	254	398	100	80	M24	210	170	28	22
IE3-W41B 355 M4	610	130	700	715	560	140	200	750	254	398	100	80	M24	210	170	28	22
IE3-W41B 355 M6, 8	610	130	700	715	560	140	200	750	254	398	100	80	M24	210	170	28	22
IE3-W41B 355 MX6, 8	610	130	700	715	560	140	200	750	254	518	100	80	M24	210	170	28	22
IE3-W41B 355 MX2	610	130	700	715	560	140	200	750	254	518	80	80	M20	170	170	22	22
IE3-W41B 355 LY2, L2	610	130	700	715	630	140	200	750	254	448	80	80	M20	170	170	22	22
IE3-W41B 355 MX4	610	130	700	715	560	140	200	750	254	448	100	80	M24	210	170	28	22
IE3-W41B 355 LY4, 6, 8, L4	610	130	700	715	630	140	200	750	254	448	100	80	M24	210	170	28	22

Type designation	GA	GC	H	HA	HD	HD ²⁾	HH	K	K'	L	LC	TB Type	AG	LL	AH	BE	O
	t	t1	h	c	p	p	A	s	s'	k	k1		x	z	-	-	r
IE3-W41B 355 MY2, M2	85	85	355	44	1088	1172	250	28	28	1365	1552	630 A	496	390	301	140	M72 x 2
IE3-W41B 355 MY4, 6, 8	106	85	355	44	1088	1172	250	28	28	1405	1592	630 A	496	390	301	140	M72 x 2
IE3-W41B 355 M4	106	85	355	44	1088	1172	250	28	28	1405	1552	630 A	496	390	301	140	M72 x 2
IE3-W41B 355 M6, 8	106	85	355	44	1088	1172	250	28	28	1405	1592	630 A	496	390	301	140	M72 x 2
IE3-W41B 355 MX6, 8	106	85	355	44	1088	1172	250	28	28	1525	1712	630 A	496	390	301	140	M72 x 2
IE3-W41B 355 MX2	85	85	355	44	1084	1174	250	28	28	1485	1672	1000 A	615	475	385	200	M72 x 2
IE3-W41B 355 LY2, L2	85	85	355	44	1084	1174	250	28	28	1485	1672	1000 A	615	475	385	200	M72 x 2
IE3-W41B 355 MX4	106	85	355	44	1084	1174	250	28	28	1525	1712	1000 A	615	475	385	200	M72 x 2
IE3-W41B 355 LY4, 6, 8, L4	106	85	355	44	1084	1174	250	28	28	1525	1712	1000 A	615	475	385	200	M72 x 2

¹⁾ Centre holes to DIN 332-DS

²⁾ Terminal box left/right

Subject to changes in the course of further development.

Size 400 upon request

Water-cooled three-phase motors with squirrel-cage rotor, Premium Efficiency IE3

Type of cooling IC 71W, duty cycle S1, continuous duty,
Thermal class 155, degree of protection IP 55
Size 355

Type of construction IM B35 [IM 2001]

Flange dimensions see page 5/9

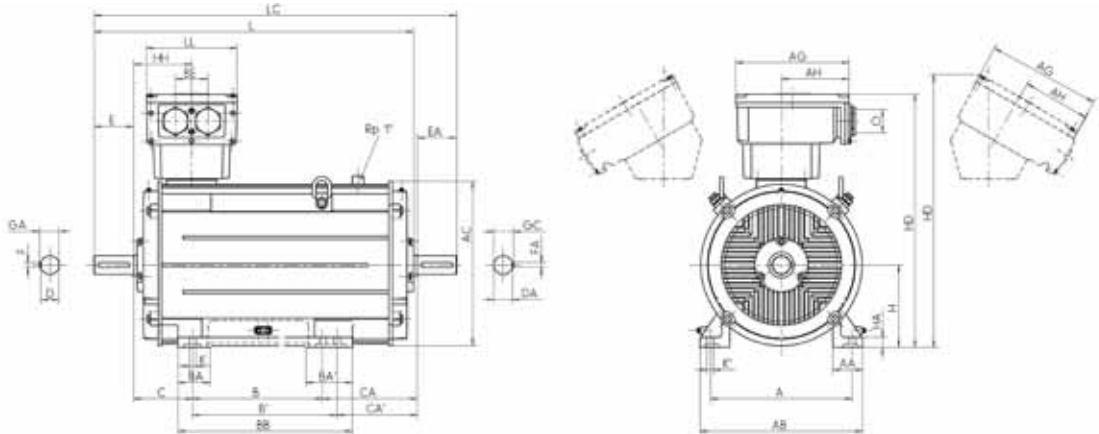

Type designation	Flange size	A	AA	AB	AC	B	BA	BA'	BB	C	CA	D	DA	DB ¹⁾	E	EA	F	FA
		b	n	f	g	a	m	m1	e	w1	w2	d	d1		l	l1	u	u1
IE3-W41B 355 MY2, M2	FF 740	610	130	700	715	560	140	200	750	254	398	80	80	M20	170	170	22	22
IE3-W41B 355 MY4, 6, 8	FF 740	610	130	700	715	560	140	200	750	254	398	100	80	M24	210	170	28	22
IE3-W41B 355 M4	FF 740	610	130	700	715	560	140	200	750	254	398	100	80	M24	210	170	28	22
IE3-W41B 355 M6, 8	FF 740	610	130	700	715	560	140	200	750	254	398	100	80	M24	210	170	28	22
IE3-W41B 355 MX6, 8	FF 740	610	130	700	715	560	140	200	750	254	518	100	80	M24	210	170	28	22
IE3-W41B 355 MX2	FF 740	610	130	700	715	560	140	200	750	254	518	80	80	M20	170	170	22	22
IE3-W41B 355 LY2, L2	FF 740	610	130	700	715	630	140	200	750	254	448	80	80	M20	170	170	22	22
IE3-W41B 355 MX4	FF 740	610	130	700	715	560	140	200	750	254	448	100	80	M24	210	170	28	22
IE3-W41B 355 LY4, 6, 8, L4	FF 740	610	130	700	715	630	140	200	750	254	448	100	80	M24	210	170	28	22

Type designation	GA	GC	H	HA	HD	HD ²⁾	HH	K	K'	L	LC	TB Type	AG	LL	AH	BE	O
	t	t1	h	c	p	p	A	s	s'	k	k1		x	z	-	-	r
IE3-W41B 355 MY2, M2	85	85	355	44	1088	1172	250	28	28	1365	1552	630 A	496	390	301	140	M72 x 2
IE3-W41B 355 MY4, 6, 8	106	85	355	44	1088	1172	250	28	28	1405	1592	630 A	496	390	301	140	M72 x 2
IE3-W41B 355 M4	106	85	355	44	1088	1172	250	28	28	1405	1552	630 A	496	390	301	140	M72 x 2
IE3-W41B 355 M6, 8	106	85	355	44	1088	1172	250	28	28	1405	1592	630 A	496	390	301	140	M72 x 2
IE3-W41B 355 MX6, 8	106	85	355	44	1088	1172	250	28	28	1525	1712	630 A	496	390	301	140	M72 x 2
IE3-W41B 355 MX2	85	85	355	44	1084	1174	250	28	28	1485	1672	1000 A	615	475	385	200	M72 x 2
IE3-W41B 355 LY2, L2	85	85	355	44	1084	1174	250	28	28	1485	1672	1000 A	615	475	385	200	M72 x 2
IE3-W41B 355 MX4	106	85	355	44	1084	1174	250	28	28	1525	1712	1000 A	615	475	385	200	M72 x 2
IE3-W41B 355 LY4, 6, 8, L4	106	85	355	44	1084	1174	250	28	28	1525	1712	1000 A	615	475	385	200	M72 x 2

¹⁾ Centre holes to DIN 332-DS

²⁾ Terminal box left/right

Subject to changes in the course of further development.

Size 400 upon request

Water-cooled three-phase motors with squirrel-cage rotor, Premium Efficiency IE3

Type of cooling IC 71W, duty cycle S1, continuous duty,
Thermal class 155, degree of protection IP 55
Size 355

Type of construction IM V1 [IM 3011]

Flange dimensions see page 5/9

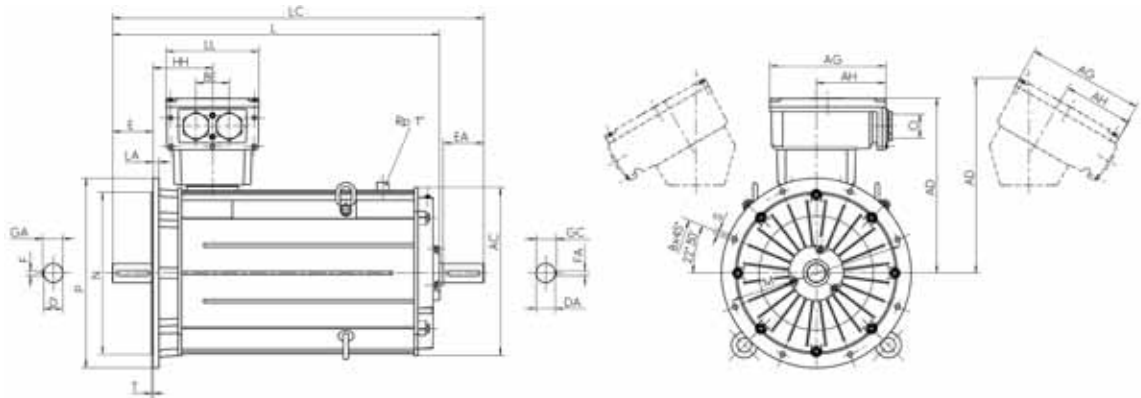

Type designation	Flange size	AC	AD	AD ^{*)}	D	DA	DB ^{*)}	E	EA	F	FA	GA	GC	H	HH	L	LC	TB Type	LL	AH	BE	O	
		g	g1	g1	d	d1		l	l1	u	u1	t	t1	h	A	k	k1	x	z	-	-	r	
IE3-W41B 355 MY2, M2	FF 740	715	733	817	80	80	M20	170	170	22	22	85	85	355	250	1365	1552	630 A	496	390	301	140	M72 x 2
IE3-W41B 355 MY4, 6, 8	FF 740	715	733	817	100	80	M24	210	170	28	22	106	85	355	250	1405	1592	630 A	496	390	301	140	M72 x 2
IE3-W41B 355 M4	FF 740	715	733	817	100	80	M24	210	170	28	22	106	85	355	250	1405	1552	630 A	496	390	301	140	M72 x 2
IE3-W41B 355 M6, 8	FF 740	715	733	817	100	80	M24	210	170	28	22	106	85	355	250	1405	1592	630 A	496	390	301	140	M72 x 2
IE3-W41B 355 MX6, 8	FF 740	715	733	819	100	80	M24	210	170	28	22	106	85	355	327	1525	1712	630 A	496	390	301	140	M72 x 2
IE3-W41B 355 MX2	FF 740	715	729	819	80	80	M20	170	170	22	22	85	85	355	327	1485	1672	1000 A	615	475	385	200	M72 x 2
IE3-W41B 355 LY2, L2	FF 740	715	729	819	80	80	M20	170	170	22	22	85	85	355	327	1485	1672	1000 A	615	475	385	200	M72 x 2
IE3-W41B 355 MX4	FF 740	715	729	819	100	80	M24	210	170	28	22	106	85	355	327	1525	1712	1000 A	615	475	385	200	M72 x 2
IE3-W41B 355 LY4, 6, 8, L4	FF 740	715	729	819	100	80	M24	210	170	28	22	106	85	355	327	1525	1712	1000 A	615	475	385	200	M72 x 2

^{*)} Centre holes to DIN 332-DS

^{**)} Terminal box left/right

Subject to changes in the course of further development.

Size 400 upon request

Water-cooled three-phase motors with squirrel-cage rotor, High Efficiency, IE2

Type of cooling IC 71W, duty cycle S1, continuous duty,
 Thermal class 155, degree of protection IP 55
 Size 225 bis 280

Type of constructionen IM B3 [IM 1001]

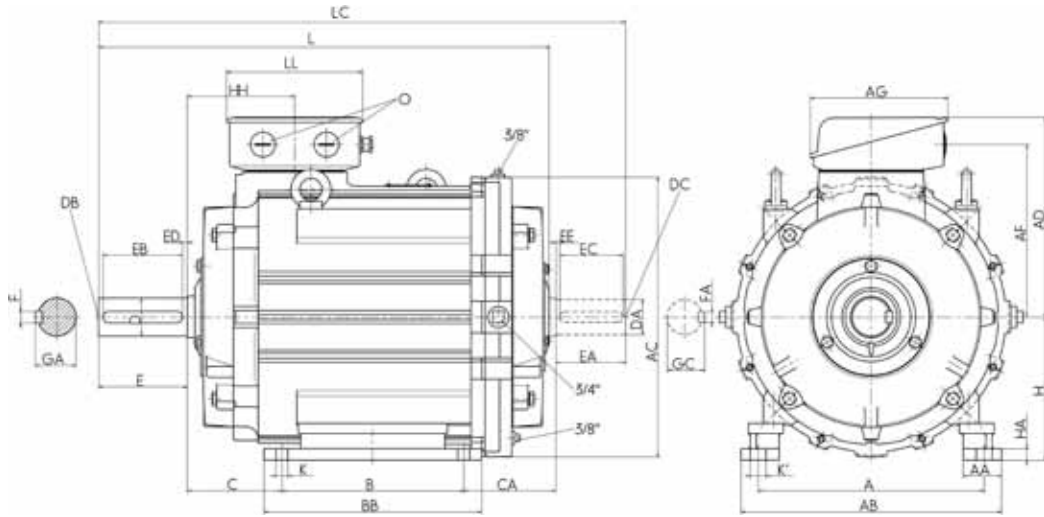

Type designation	Flange size	DS-Shaft ends																	
		A	AA	AB	AC	AD	AD'	AF	B	BB	C	CA	D	DB	E	EB	ED	F	
	b	n	f	g	KL/KR	g1	a	e	w1	w2	d	-	l				u		
IE2-WE1B- 225 S2	FF 400	356	75	413	390	300	217	300	240	286	343	149	196	55	M20	110	100	5	16
IE2-WE1B- 225 S4, 8	FF 400	356	75	413	390	300	217	300	240	286	343	149	196	60	M20	140	125	7.5	18
IE2-WE1B- 225 M2	FF 400	356	75	413	390	300	217	300	240	311	368	149	211	55	M20	110	100	5	16
IE2-WE1B- 225 M4	FF 400	356	75	413	390	300	217	300	240	311	368	149	211	60	M20	140	125	7.5	18
IE2-WE1B- 225 M6, 8	FF 400	356	75	413	390	300	217	300	240	311	368	149	171	60	M20	140	125	7.5	18
IE2-WE1B- 250 M2	FF 500	406	84	471	440	358	234	358	282	349	412	168	210	60	M20	140	125	7.5	18
IE2-WE1B- 250 M4, 6, 8	FF 500	406	84	471	440	358	234	358	282	349	412	168	210	65	M20	140	125	7.5	18
IE2-WE1B- 280 S2	FF 500	457	94	522	490	386	266	386	310	368	431	190	234	65	M20	140	125	7.5	18
IE2-WE1B- 280 M2	FF 500	457	94	522	490	386	266	386	310	419	482	190	229	65	M20	140	125	7.5	18
IE2-WE1B- 280 S4, 6, 8	FF 500	457	94	522	490	386	266	386	310	368	431	190	234	75	M20	140	125	7.5	20
IE2-WE1B- 280 M4, 6, 8	FF 500	457	94	522	490	386	266	386	310	419	482	190	229	75	M20	140	125	7.5	20

Type designation	NS-Shaft ends																		
	GA	DA	DC	EA	EC	EE	FA	GC	H	HA	HH	K	K'	L	LC	TB Type	LL	AG	O
	t	d1	l1			u1	t1	h	c	A	s	s'	k	k1		z	x	-	
IE2-WE1B- 225 S2	59	55	M16	110	100	5	16	59	225	25	168	19	25	680	800	100 A	207	212	2 x M50 x 1.5
IE2-WE1B- 225 S4, 8	64	55	M16	110	100	5	16	59	225	25	168	19	25	710	830	100 A	207	212	2 x M50 x 1.5
IE2-WE1B- 225 M2	59	55	M16	110	100	5	16	59	225	25	168	19	25	680	800	100 A	207	212	2 x M50 x 1.5
IE2-WE1B- 225 M4	64	55	M16	110	100	5	16	59	225	25	168	19	25	710	830	100 A	207	212	2 x M50 x 1.5
IE2-WE1B- 225 M6, 8	64	55	M16	110	100	5	16	59	225	25	168	19	25	710	830	100 A	207	212	2 x M50 x 1.5
IE2-WE1B- 250 M2	64	55	M16	110	100	5	16	59	250	28	177	24	30	737	857	200 A	242	282	2 x M63 x 1.5
IE2-WE1B- 250 M4, 6, 8	69	55	M16	110	100	5	16	59	250	28	177	24	30	737	857	200 A	242	282	2 x M63 x 1.5
IE2-WE1B- 280 S2	69	65	M20	140	125	7.5	18	69	280	32	206	24	30	875	1028	200 A	242	282	2 x M63 x 1.5
IE2-WE1B- 280 M2	69	65	M20	140	125	7.5	18	69	280	32	206	24	30	875	1028	200 A	242	282	2 x M63 x 1.5
IE2-WE1B- 280 S4, 6, 8	79.5	65	M20	140	125	7.5	18	69	280	32	206	24	30	875	1028	200 A	242	282	2 x M63 x 1.5
IE2-WE1B- 280 M4, 6, 8	79.5	65	M20	140	125	7.5	18	69	280	32	206	24	30	875	1028	200 A	242	282	2 x M63 x 1.5

Water-cooled three-phase motors with squirrel-cage rotor, High Efficiency, IE2

Type of cooling IC 71W, duty cycle S1, continuous duty,
 Thermal class 155, degree of protection IP 55
 Size 225 bis 280

IM B35 [IM 2001]

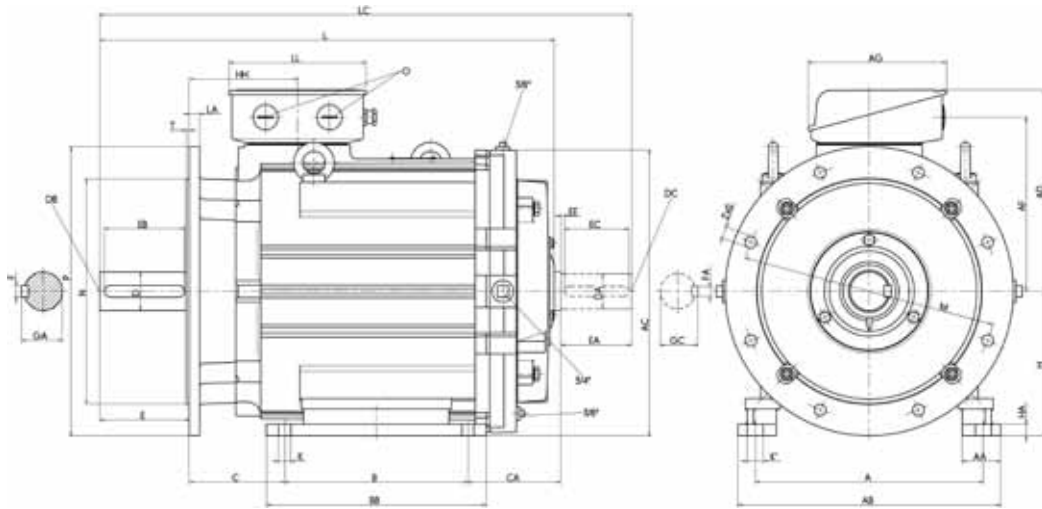

Type designation	Tolerances				Mating parts
	H	N	D	DA	
IE2-WE1B- 225 S2	-0.5	h6	m6	m6	H7
IE2-WE1B- 225 S4, 8	-0.5	h6	m6	m6	H7
IE2-WE1B- 225 M2	-0.5	h6	m6	m6	H7
IE2-WE1B- 225 M4	-0.5	h6	m6	m6	H7
IE2-WE1B- 225 M6, 8	-0.5	h6	m6	m6	H7
IE2-WE1B- 250 M2	-0.5	h6	m6	m6	H7
IE2-WE1B- 250 M4, 6, 8	-0.5	h6	m6	m6	H7
IE2-WE1B- 280 S2	-1	h6	m6	m6	H7
IE2-WE1B- 280 M2	-1	h6	m6	m6	H7
IE2-WE1B- 280 S4, 6, 8	-1	h6	m6	m6	H7
IE2-WE1B- 280 M4, 6, 8	-1	h6	m6	m6	H7

Water-cooled three-phase motors with squirrel-cage rotor, High Efficiency, IE2

Type of cooling IC 71W, duty cycle S1, continuous duty,
 Thermal class 155, degree of protection IP 55
 Size 225 bis 280

Type of constructionen IM B5 [IM 3001]

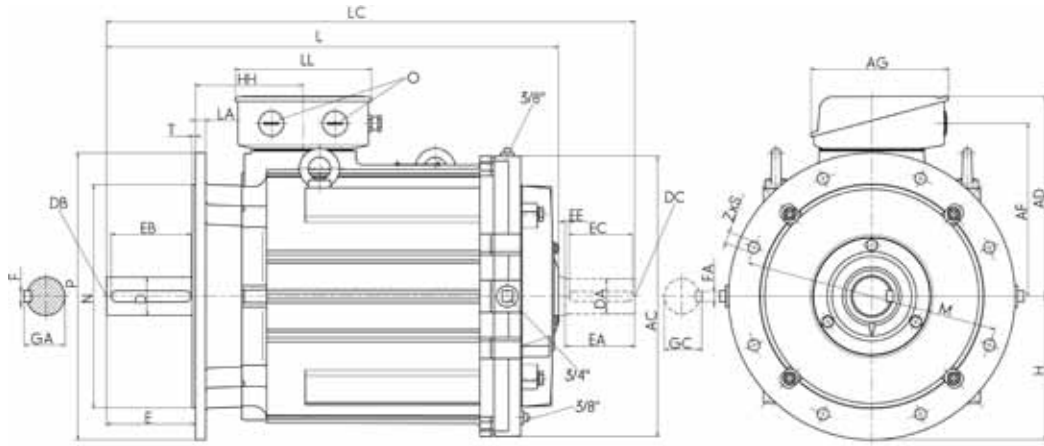

Type designation	Flange size	A	AA	AB	AC	AD	AD	AD'	AF	B	BB	C	CA	H	HA	HH	K	K'	L	LC	TB	LL	AG	O
		b	n	f	g		KL/KR	g1		a	e	w1	w2	d	-	l			u	Type				
IE2-WE1B- 225 S2	FF 400	356	75	413	390	300	217	300	240	286	343	149	196	225	25	168	19	25	680	800	100 A	207	212	2 x M50 x 1.5
IE2-WE1B- 225 S4, 8	FF 400	356	75	413	390	300	217	300	240	286	343	149	196	225	25	168	19	25	710	830	100 A	207	212	2 x M50 x 1.5
IE2-WE1B- 225 M2	FF 400	356	75	413	390	300	217	300	240	311	368	149	211	225	25	168	19	25	680	800	100 A	207	212	2 x M50 x 1.5
IE2-WE1B- 225 M4	FF 400	356	75	413	390	300	217	300	240	311	368	149	211	225	25	168	19	25	710	830	100 A	207	212	2 x M50 x 1.5
IE2-WE1B- 225 M6, 8	FF 400	356	75	413	390	300	217	300	240	311	368	149	171	225	25	168	19	25	710	830	100 A	207	212	2 x M50 x 1.5
IE2-WE1B- 250 M2	FF 500	406	84	471	440	358	234	358	282	349	412	168	210	250	28	177	24	30	737	857	200 A	242	282	2 x M63 x 1.5
IE2-WE1B- 250 M4, 6, 8	FF 500	406	84	471	440	358	234	358	282	349	412	168	210	250	28	177	24	30	737	857	200 A	242	282	2 x M63 x 1.5
IE2-WE1B- 280 S2	FF 500	457	94	522	490	386	266	386	310	368	431	190	234	280	32	206	24	30	875	1028	200 A	242	282	2 x M63 x 1.5
IE2-WE1B- 280 M2	FF 500	457	94	522	490	386	266	386	310	419	482	190	229	280	32	206	24	30	875	1028	200 A	242	282	2 x M63 x 1.5
IE2-WE1B- 280 S4, 6, 8	FF 500	457	94	522	490	386	266	386	310	368	431	190	234	280	32	206	24	30	875	1028	200 A	242	282	2 x M63 x 1.5
IE2-WE1B- 280 M4, 8	FF 500	457	94	522	490	386	266	386	310	419	482	190	229	280	32	206	24	30	875	1028	200 A	242	282	2 x M63 x 1.5

Type designation	DS-Schaft ends											NS-Schaft ends										Tolerances				Mating parts		
	LA	M	N	S	T	D	DB	E	EB	ED	F	GA	DA	DC	EA	EC	EE	FA	GC	-	-	-	-	H	N		D	DA
	c1	e1	b1	s1	f1	d	-	l		u	t	d1	l1		u1	t1												
IE2-WE1B- 225 S2	16	400	350	18	5	55	M20	110	100	5	16	59	55	M16	110	100	5	16	59	-0.5	h6	m6	m6	H7				
IE2-WE1B- 225 S4, 8	16	400	350	18	5	60	M20	140	125	7.5	18	64	55	M16	110	100	5	16	59	-0.5	h6	m6	m6	H7				
IE2-WE1B- 225 M2	16	400	350	18	5	55	M20	110	100	5	16	59	55	M16	110	100	5	16	59	-0.5	h6	m6	m6	H7				
IE2-WE1B- 225 M4	16	400	350	18	5	60	M20	140	125	7.5	18	64	55	M16	110	100	5	16	59	-0.5	h6	m6	m6	H7				
IE2-WE1B- 225 M6, 8	16	400	350	18	5	60	M20	140	125	7.5	18	64	55	M16	110	100	5	16	59	-0.5	h6	m6	m6	H7				
IE2-WE1B- 250 M2	18	500	450	18	5	60	M20	140	125	7.5	18	64	55	M16	110	100	5	16	59	-0.5	h6	m6	m6	H7				
IE2-WE1B- 250 M4, 6, 8	18	500	450	18	5	65	M20	140	125	7.5	18	69	55	M16	110	100	5	16	59	-0.5	h6	m6	m6	H7				
IE2-WE1B- 280 S2	18	500	450	18	5	65	M20	140	125	7.5	18	69	65	M20	140	125	7.5	18	69	-1	h6	m6	m6	H7				
IE2-WE1B- 280 M2	18	500	450	18	5	65	M20	140	125	7.5	18	69	65	M20	140	125	7.5	18	69	-1	h6	m6	m6	H7				
IE2-WE1B- 280 S4, 6, 8	18	500	450	18	5	75	M20	140	125	7.5	20	79.5	65	M20	140	125	7.5	18	69	-1	h6	m6	m6	H7				
IE2-WE1B- 280 M4, 8	18	500	450	18	5	75	M20	140	125	7.5	20	79.5	65	M20	140	125	7.5	18	69	-1	h6	m6	m6	H7				

Water-cooled three-phase motors with squirrel-cage rotor, Premium Efficiency IE2

Type of cooling IC 71W, duty cycle S1, continuous duty,
Thermal class 155, degree of protection IP 55
Size 315

Type of construction IM B3 [IM 1001]

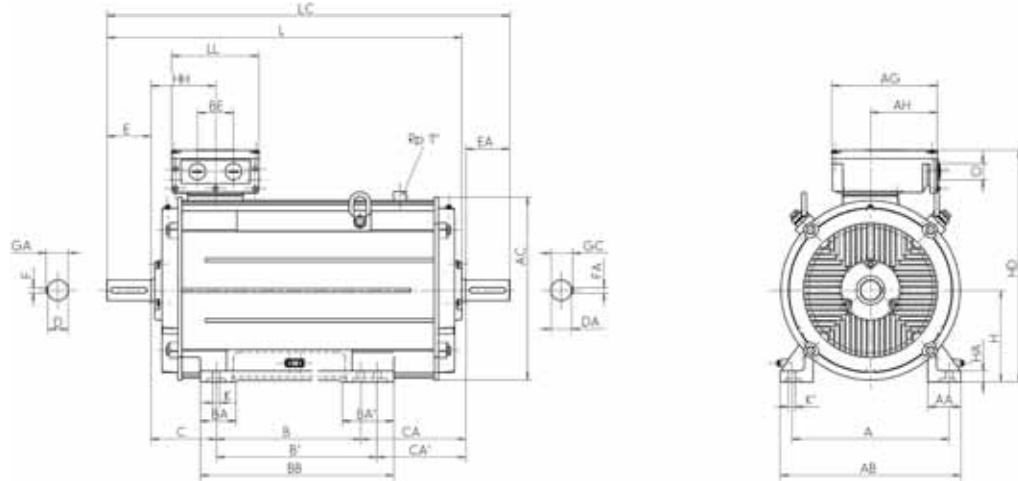

Type designation	A	AA	AB	AC	B	BA	BA'	BB	C	CA	D	DA	DB ¹⁾	E	EA	F	FA
	b	n	f	g	a	m	m1	e	w1	w2	d	d1		l	l1	u	u1
IE2-WE1B 315 S2	508	126	590	550	406	120	-	503	216	126	65	65	M20	140	140	18	18
IE2-WE1B 315 S4, 6, 8	508	126	590	550	406	120	-	503	216	126	80	70	M20	170	140	22	20
IE2-WE1B 315 M2	508	126	590	550	457	120	-	554	216	130	65	65	M20	140	140	18	18
IE2-WE1B 315 M4, 6, 8	508	126	590	550	457	120	-	554	216	130	80	70	M20	170	140	22	20
IE2-WE1B 315 MX2	508	126	590	550	457	120	150	554	216	208	65	65	M20	140	140	18	18
IE2-WE1B 315 MX4	508	126	590	550	457	120	150	554	216	208	80	70	M20	170	140	22	20
IE2-WE1B 315 MX6, 8	508	126	590	550	457	120	150	554	216	128	80	70	M20	170	140	22	20
IE2-WE1B 315 MX10, 12	508	126	590	550	457	120	150	554	216	128	80	70	M20	170	140	22	20
IE2-WE1B 315 MY2	508	110	590	610	457	120	-	573	216	307	65	65	M20	140	140	18	18
IE2-WE1B 315 MY4, 6, 8	508	110	590	610	457	120	-	573	216	307	80	70	M20	170	140	22	20
IE2-WE1B 315 L2	508	110	590	610	508	120	-	624	216	376	65	65	M20	140	140	18	18
IE2-WE1B 315 L4, 6, 8	508	110	590	610	508	120	-	624	216	376	80	70	M20	170	140	22	20
IE2-WE1B 315 LX2	508	110	590	610	508	120	-	624	216	496	65	65	M20	140	140	18	18
IE2-WE1B 315 LX4	508	110	590	610	508	120	-	624	216	496	80	70	M20	170	140	22	20
IE2-WE1B 315 LX6, 8	508	110	590	610	508	120	-	624	216	376	80	70	M20	170	140	22	20

Type designation	GA	GC	H	HA	HD	HH	K	K'	L	LC	TB Type	AG	LL	AH	Ø
	t	t1	h	c	p	A	s	s'	k	k1				-	
IE2-WE1B 315 S2	69	69	315	44	731	211	28	35	879	1026	200 A	282	242	-	M63 x 1.5
IE2-WE1B 315 S4, 6, 8	85	74.5	315	44	731	211	28	35	909	1056	200 A	282	242	-	M63 x 1.5
IE2-WE1B 315 M2	69	69	315	44	731	211	28	35	934	1081	200 A	282	242	-	M63 x 1.5
IE2-WE1B 315 M4, 6, 8	85	74.5	315	44	731	211	28	35	964	1111	200 A	282	242	-	M63 x 1.5
IE2-WE1B 315 MX2	69	69	315	44	731	211	28	35	1014	1161	200 A	282	242	-	M63 x 1.5
IE2-WE1B 315 MX4	85	74.5	315	44	731	211	28	35	1044	1191	200 A	282	242	-	M63 x 1.5
IE2-WE1B 315 MX6, 8	85	74.5	315	44	731	211	28	35	964	1111	200 A	282	242	-	M63 x 1.5
IE2-WE1B 315 MX10, 12	85	74.5	315	44	731	211	28	35	964	1111	200 A	282	242	-	M63 x 1.5
IE2-WE1B 315 MY2	69	69	315	44	809	230	28	35	1116	1260	400 A SB	415	340	265	M63 x 1.5
IE2-WE1B 315 MY4, 6, 8	85	74.5	315	44	809	230	28	35	1146	1290	400 A SB	415	340	265	M63 x 1.5
IE2-WE1B 315 L2	69	69	315	44	809	230	28	35	1236	1380	400 A SB	415	340	265	M63 x 1.5
IE2-WE1B 315 L4, 6, 8	85	74.5	315	44	809	230	28	35	1266	1410	400 A SB	415	340	265	M63 x 1.5
IE2-WE1B 315 LX2	69	69	315	44	809	230	28	35	1356	1500	400 A SB	415	340	265	M63 x 1.5
IE2-WE1B 315 LX4	85	74.5	315	44	809	230	28	35	1386	1530	400 A SB	415	340	265	M63 x 1.5
IE2-WE1B 315 LX6, 8	85	74.5	315	44	809	230	28	35	1266	1410	400 A SB	415	340	265	M63 x 1.5

¹⁾ Centre holes to DIN 332-DS

Subject to changes in the course of further development.

Water-cooled three-phase motors with squirrel-cage rotor, Premium Efficiency IE2

Type of cooling IC 71W, duty cycle S1, continuous duty,
 Thermal class 155, degree of protection IP 55
 Size 315

Type of construction IM B35 [IM 2001]

Flange dimensions see page 5/9

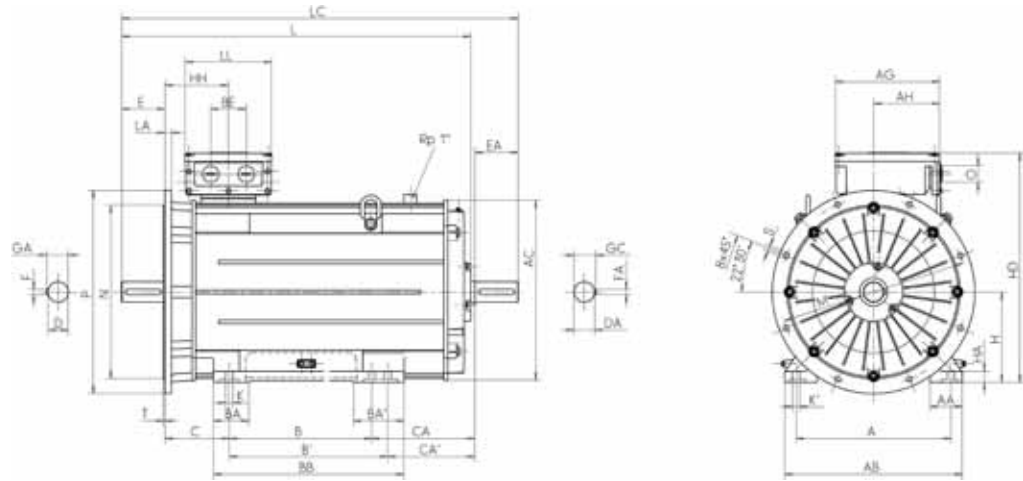

Type designation	Flange size	A	AA	AB	AC	B	BA	BA'	BB	C	CA	D	DA	DB ¹⁾	E	EA	F	FA
		b	n	f	g	a	m	m1	e	w1	w2	d	d1		l	l1	u	u1
IE2-WE1B 315 S2	FF 600	508	126	590	550	406	120	-	503	216	126	65	65	M20	140	140	18	18
IE2-WE1B 315 S4, 6, 8	FF 600	508	126	590	550	406	120	-	503	216	126	80	70	M20	170	140	22	20
IE2-WE1B 315 M2	FF 600	508	126	590	550	457	120	-	554	216	130	65	65	M20	140	140	18	18
IE2-WE1B 315 M4, 6, 8	FF 600	508	126	590	550	457	120	-	554	216	130	80	70	M20	170	140	22	20
IE2-WE1B 315 MX2	FF 600	508	126	590	550	457	120	150	554	216	208	65	65	M20	140	140	18	18
IE2-WE1B 315 MX4	FF 600	508	126	590	550	457	120	150	554	216	208	80	70	M20	170	140	22	20
IE2-WE1B 315 MX6, 8	FF 600	508	126	590	550	457	120	150	554	216	128	80	70	M20	170	140	22	20
IE2-WE1B 315 MX10, 12	FF 600	508	126	590	550	457	120	150	554	216	128	80	70	M20	170	140	22	20
IE2-WE1B 315 MY2	FF 600	508	110	590	610	457	120	-	573	216	307	65	65	M20	140	140	18	18
IE2-WE1B 315 MY4, 6, 8	FF 600	508	110	590	610	457	120	-	573	216	307	80	70	M20	170	140	22	20
IE2-WE1B 315 L2	FF 600	508	110	590	610	508	120	-	624	216	376	65	65	M20	140	140	18	18
IE2-WE1B 315 L4, 6, 8	FF 600	508	110	590	610	508	120	-	624	216	376	80	70	M20	170	140	22	20
IE2-WE1B 315 LX2	FF 600	508	110	590	610	508	120	-	624	216	496	65	65	M20	140	140	18	18
IE2-WE1B 315 LX4	FF 600	508	110	590	610	508	120	-	624	216	496	80	70	M20	170	140	22	20
IE2-WE1B 315 LX6, 8	FF 600	508	110	590	610	508	120	-	624	216	376	80	70	M20	170	140	22	20

Type designation	GA	GC	H	HA	HD	HH	K	K'	L	LC	TB Type	AG	LL	AH	0
	t	t1	h	c	p	A	s	s'	k	k1				-	
IE2-WE1B 315 S2	69	69	315	44	731	211	28	35	879	1026	200 A	282	242	-	M63 x 1.5
IE2-WE1B 315 S4, 6, 8	85	74.5	315	44	731	211	28	35	909	1056	200 A	282	242	-	M63 x 1.5
IE2-WE1B 315 M2	69	69	315	44	731	211	28	35	934	1081	200 A	282	242	-	M63 x 1.5
IE2-WE1B 315 M4, 6, 8	85	74.5	315	44	731	211	28	35	964	1111	200 A	282	242	-	M63 x 1.5
IE2-WE1B 315 MX2	69	69	315	44	731	211	28	35	1014	1161	200 A	282	242	-	M63 x 1.5
IE2-WE1B 315 MX4	85	74.5	315	44	731	211	28	35	1044	1191	200 A	282	242	-	M63 x 1.5
IE2-WE1B 315 MX6, 8	85	74.5	315	44	731	211	28	35	964	1111	200 A	282	242	-	M63 x 1.5
IE2-WE1B 315 MX10, 12	85	74.5	315	44	731	211	28	35	964	1111	200 A	282	242	-	M63 x 1.5
IE2-WE1B 315 MY2	69	69	315	44	809	230	28	35	1116	1260	400 A-SB	415	340	265	M63 x 1.5
IE2-WE1B 315 MY4, 6, 8	85	74.5	315	44	809	230	28	35	1146	1290	400 A-SB	415	340	265	M63 x 1.5
IE2-WE1B 315 L2	69	69	315	44	809	230	28	35	1236	1380	400 A-SB	415	340	265	M63 x 1.5
IE2-WE1B 315 L4, 6, 8	85	74.5	315	44	809	230	28	35	1266	1410	400 A-SB	415	340	265	M63 x 1.5
IE2-WE1B 315 LX2	69	69	315	44	809	230	28	35	1356	1500	400 A-SB	415	340	265	M63 x 1.5
IE2-WE1B 315 LX4	85	74.5	315	44	809	230	28	35	1386	1530	400 A-SB	415	340	265	M63 x 1.5
IE2-WE1B 315 LX6, 8	85	74.5	315	44	809	230	28	35	1266	1410	400 A-SB	415	340	265	M63 x 1.5

¹⁾ Centre holes to DIN 332-DS

Subject to changes in the course of further development.

Water-cooled three-phase motors with squirrel-cage rotor, Premium Efficiency IE2

Type of cooling IC 71W, duty cycle S1, continuous duty,
Thermal class 155, degree of protection IP 55
Size 315

Type of construction IM B5 [IM 3001] to type of construction 315 MY
Type of construction IM V1 [IM 3011]

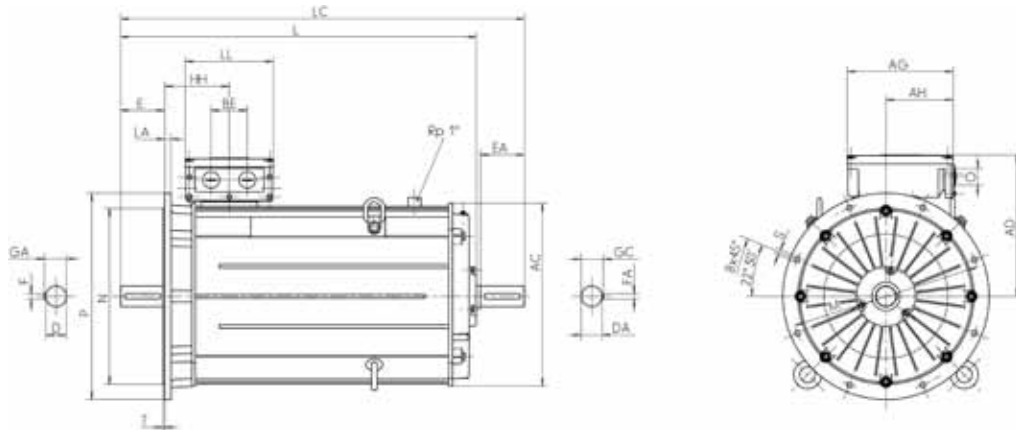

Type designation	Flange size	AC g	AD g1	D d	DA d1	DB ¹⁾	E l	EA l1	F u	FA u1	GA t	GC t1	H h	HH A	L k	LC k1	TB Type	AG x	LL z	AH -	O r
IE2-WE1B 315 S2	FF 600	550	416	65	65	M20	140	140	18	18	69	69	315	211	879	1026	200 A	282	242	-	M63 x 1.5
IE2-WE1B 315 S4, 6, 8	FF 600	550	416	80	70	M20	170	140	22	20	85	74.5	315	211	909	1056	200 A	282	242	-	M63 x 1.5
IE2-WE1B 315 M2	FF 600	550	416	65	65	M20	140	140	18	18	69	69	315	211	934	1081	200 A	282	242	-	M63 x 1.5
IE2-WE1B 315 M4, 6, 8	FF 600	550	416	80	70	M20	170	140	22	20	85	74.5	315	211	964	1111	200 A	282	242	-	M63 x 1.5
IE2-WE1B 315 MX2	FF 600	550	416	65	65	M20	140	140	18	18	69	69	315	211	1014	1161	200 A	282	242	-	M63 x 1.5
IE2-WE1B 315 MX4	FF 600	550	416	80	70	M20	170	140	22	20	85	74.5	315	211	1044	1191	200 A	282	242	-	M63 x 1.5
IE2-WE1B 315 MX6, 8	FF 600	550	416	80	70	M20	170	140	22	20	85	74.5	315	211	964	1111	200 A	282	242	-	M63 x 1.5
IE2-WE1B 315 MX10, 12	FF 600	550	416	80	70	M20	170	140	22	20	85	74.5	315	211	964	1111	200 A	282	242	-	M63 x 1.5
IE2-WE1B 315 MY2	FF 600	610	494	65	65	M20	140	140	18	18	69	69	315	230	1116	1260	400 A-SB	415	340	265	M63 x 1.5
IE2-WE1B 315 MY4, 6, 8	FF 600	610	494	80	70	M20	170	140	22	20	85	74.5	315	230	1146	1290	400 A-SB	415	340	265	M63 x 1.5
IE2-WE1B 315 L2	FF 600	610	494	65	65	M20	140	140	18	18	69	69	315	230	1236	1380	400 A-SB	415	340	265	M63 x 1.5
IE2-WE1B 315 L4, 6, 8	FF 600	610	494	80	70	M20	170	140	22	20	85	74.5	315	230	1266	1410	400 A-SB	415	340	265	M63 x 1.5
IE2-WE1B 315 LX2	FF 600	610	494	65	65	M20	140	140	18	18	69	69	315	230	1356	1500	400 A-SB	415	340	265	M63 x 1.5
IE2-WE1B 315 LX4	FF 600	610	494	80	70	M20	170	140	22	20	85	74.5	315	230	1386	1530	400 A-SB	415	340	265	M63 x 1.5
IE2-WE1B 315 LX6, 8	FF 600	610	494	80	70	M20	170	140	22	20	85	74.5	315	230	1266	1410	400 A-SB	415	340	265	M63 x 1.5

¹⁾ Centre holes to DIN 332-DS

Subject to changes in the course of further development.

Water-cooled three-phase motors with squirrel-cage rotor, Premium Efficiency IE2

Type of cooling IC 71W, duty cycle S1, continuous duty,
 Thermal class 155, degree of protection IP 55
 Size 355

Type of construction IM B3 [IM 1001]

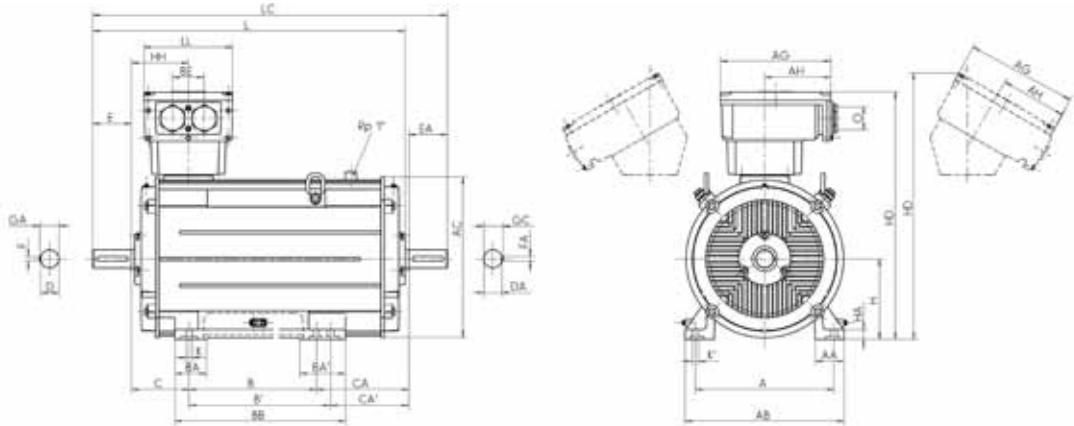

Type designation	A	AA	AB	AC	B	BA	BA'	BB	C	CA	D	DA	DB ¹⁾	E	EA	F	FA
	b	n	f	g	a	m	m1	e	w1	w2	d	d1		l	l1	u	u1
IE2-WE2B 355 MY2, M2	610	130	700	715	560	140	200	750	254	398	80	80	M20	170	170	22	22
IE2-WE2B 355 MY4, 6, 8	610	130	700	715	560	140	200	750	254	398	100	80	M24	210	170	28	22
IE2-WE2B 355 M4	610	130	700	715	560	140	200	750	254	398	100	80	M24	210	170	28	22
IE2-WE2B 355 M6, 8	610	130	700	715	560	140	200	750	254	398	100	80	M24	210	170	28	22
IE2-WE2B 355 MX6, 8	610	130	700	715	560	140	200	750	254	518	100	80	M24	210	170	28	22
IE2-WE2B 355 MX2	610	130	700	715	560	140	200	750	254	518	80	80	M20	170	170	22	22
IE2-WE2B 355 LY2, L2	610	130	700	715	630	140	200	750	254	448	80	80	M20	170	170	22	22
IE2-WE2B 355 MX4	610	130	700	715	560	140	200	750	254	448	100	80	M24	210	170	28	22
IE2-WE2B 355 LY4, 6, 8, L4	610	130	700	715	630	140	200	750	254	448	100	80	M24	210	170	28	22

Type designation	GA	GC	H	HA	HD	HD ²⁾	HH	K	K'	L	LC	TB Type	AG	LL	AH	BE	O
	t	t1	h	c	p	p	A	s	s'	k	k1		x	z	-	-	r
IE2-WE2B 355 MY2, M2	85	85	355	44	1088	1172	250	28	28	1365	1552	630 A	496	390	301	140	M72 x 2
IE2-WE2B 355 MY4, 6, 8	106	85	355	44	1088	1172	250	28	28	1405	1592	630 A	496	390	301	140	M72 x 2
IE2-WE2B 355 M4	106	85	355	44	1088	1172	250	28	28	1405	1552	630 A	496	390	301	140	M72 x 2
IE2-WE2B 355 M6, 8	106	85	355	44	1088	1172	250	28	28	1405	1592	630 A	496	390	301	140	M72 x 2
IE2-WE2B 355 MX6, 8	106	85	355	44	1088	1172	250	28	28	1525	1712	630 A	496	390	301	140	M72 x 2
IE2-WE2B 355 MX2	85	85	355	44	1084	1174	250	28	28	1485	1672	1000 A	615	475	385	200	M72 x 2
IE2-WE2B 355 LY2, L2	85	85	355	44	1084	1174	250	28	28	1485	1672	1000 A	615	475	385	200	M72 x 2
IE2-WE2B 355 MX4	106	85	355	44	1084	1174	250	28	28	1525	1712	1000 A	615	475	385	200	M72 x 2
IE2-WE2B 355 LY4, 6, 8, L4	106	85	355	44	1084	1174	250	28	28	1525	1712	1000 A	615	475	385	200	M72 x 2

¹⁾ Centre holes to DIN 332-DS

²⁾ Terminal box left/right

Subject to changes in the course of further development.

Water-cooled three-phase motors with squirrel-cage rotor, Premium Efficiency IE2

Type of cooling IC 71W, duty cycle S1, continuous duty,
Thermal class 155, degree of protection IP 55
Size 355

Type of construction IM B35 [IM 2001]

Flange dimensions see page 5/9

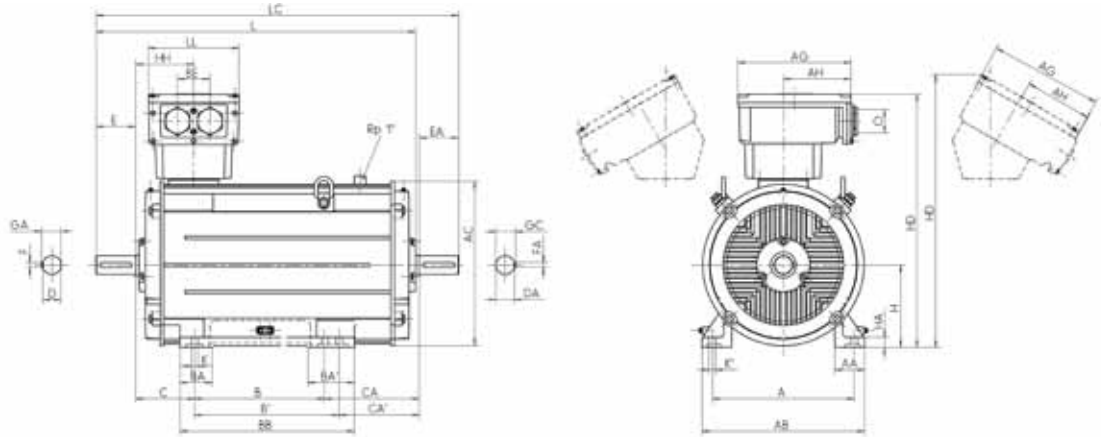

Type designation	Flange size	A	AA	AB	AC	B	BA	BA'	BB	C	CA	D	DA	DB ¹⁾	E	EA	F	FA
		b	n	f	g	a	m	m1	e	w1	w2	d	d1		l	l1	u	u1
IE3-W41B 355 MY2, M2	FF 740	610	130	700	715	560	140	200	750	254	398	80	80	M20	170	170	22	22
IE3-W41B 355 MY4, 6, 8	FF 740	610	130	700	715	560	140	200	750	254	398	100	80	M24	210	170	28	22
IE3-W41B 355 M4	FF 740	610	130	700	715	560	140	200	750	254	398	100	80	M24	210	170	28	22
IE3-W41B 355 M6, 8	FF 740	610	130	700	715	560	140	200	750	254	398	100	80	M24	210	170	28	22
IE3-W41B 355 MX6, 8	FF 740	610	130	700	715	560	140	200	750	254	518	100	80	M24	210	170	28	22
IE3-W41B 355 MX2	FF 740	610	130	700	715	560	140	200	750	254	518	80	80	M20	170	170	22	22
IE3-W41B 355 LY2, L2	FF 740	610	130	700	715	630	140	200	750	254	448	80	80	M20	170	170	22	22
IE3-W41B 355 MX4	FF 740	610	130	700	715	560	140	200	750	254	448	100	80	M24	210	170	28	22
IE3-W41B 355 LY4, 6, 8, L4	FF 740	610	130	700	715	630	140	200	750	254	448	100	80	M24	210	170	28	22

Type designation	GA	GC	H	HA	HD	HD ¹⁾	HH	K	K'	L	LC	TB Type	AG	LL	AH	BE	O
	t	t1	h	c	p	p	A	s	s'	k	k1		x	z	-	-	r
IE3-W41B 355 MY2, M2	85	85	355	44	1088	1172	250	28	28	1365	1552	630 A	496	390	301	140	M72 x 2
IE3-W41B 355 MY4, 6, 8	106	85	355	44	1088	1172	250	28	28	1405	1592	630 A	496	390	301	140	M72 x 2
IE3-W41B 355 M4	106	85	355	44	1088	1172	250	28	28	1405	1552	630 A	496	390	301	140	M72 x 2
IE3-W41B 355 M6, 8	106	85	355	44	1088	1172	250	28	28	1405	1592	630 A	496	390	301	140	M72 x 2
IE3-W41B 355 MX6, 8	106	85	355	44	1088	1172	250	28	28	1525	1712	630 A	496	390	301	140	M72 x 2
IE3-W41B 355 MX2	85	85	355	44	1084	1174	250	28	28	1485	1672	1000 A	615	475	385	200	M72 x 2
IE3-W41B 355 LY2, L2	85	85	355	44	1084	1174	250	28	28	1485	1672	1000 A	615	475	385	200	M72 x 2
IE3-W41B 355 MX4	106	85	355	44	1084	1174	250	28	28	1525	1712	1000 A	615	475	385	200	M72 x 2
IE3-W41B 355 LY4, 6, 8, L4	106	85	355	44	1084	1174	250	28	28	1525	1712	1000 A	615	475	385	200	M72 x 2

¹⁾ Centre holes to DIN 332-DS

²⁾ Terminal box left/right

Subject to changes in the course of further development.

Water-cooled three-phase motors with squirrel-cage rotor, Premium Efficiency IE2

Type of cooling IC 71W, duty cycle S1, continuous duty,
 Thermal class 155, degree of protection IP 55
 Size 355

Type of construction IM V1 [IM 3011]

Flange dimensions see page 5/9

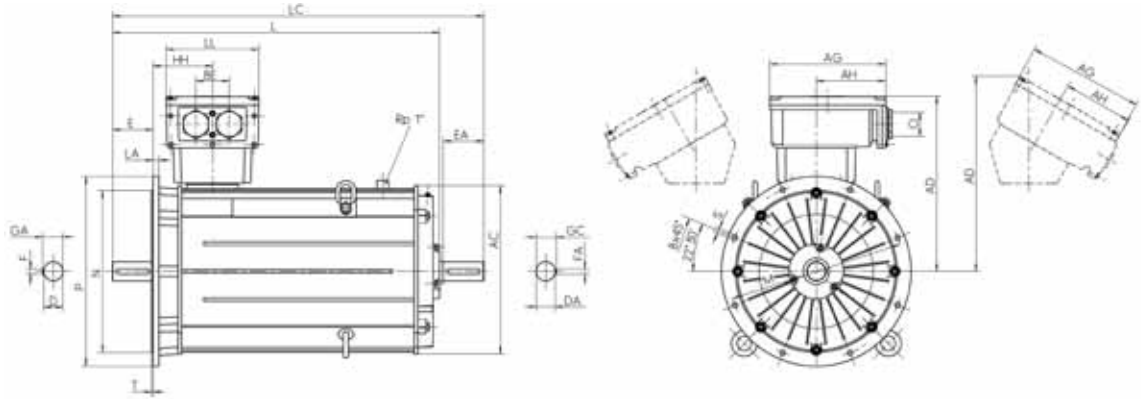

Type designation	Flange size	AC	AD	AD** ¹⁾	D	DA	DB ²⁾	E	EA	F	FA	GA	GC	H	HH	L	LC	TB Type	LL	AH	BE	O	
		g	g1	g1	d	d1		l	l1	u	u1	t	t1	h	A	k	k1	x	z	-	-	r	
IE3-W41B 355 MY2, M2	FF 740	715	733	817	80	80	M20	170	170	22	22	85	85	355	250	1365	1552	630 A	496	390	301	140	M72 x 2
IE3-W41B 355 MY4, 6, 8	FF 740	715	733	817	100	80	M24	210	170	28	22	106	85	355	250	1405	1592	630 A	496	390	301	140	M72 x 2
IE3-W41B 355 M4	FF 740	715	733	817	100	80	M24	210	170	28	22	106	85	355	250	1405	1552	630 A	496	390	301	140	M72 x 2
IE3-W41B 355 M6, 8	FF 740	715	733	817	100	80	M24	210	170	28	22	106	85	355	250	1405	1592	630 A	496	390	301	140	M72 x 2
IE3-W41B 355 MX6, 8	FF 740	715	733	819	100	80	M24	210	170	28	22	106	85	355	327	1525	1712	630 A	496	390	301	140	M72 x 2
IE3-W41B 355 MX2	FF 740	715	729	819	80	80	M20	170	170	22	22	85	85	355	327	1485	1672	1000 A	615	475	385	200	M72 x 2
IE3-W41B 355 LY2, L2	FF 740	715	729	819	80	80	M20	170	170	22	22	85	85	355	327	1485	1672	1000 A	615	475	385	200	M72 x 2
IE3-W41B 355 MX4	FF 740	715	729	819	100	80	M24	210	170	28	22	106	85	355	327	1525	1712	1000 A	615	475	385	200	M72 x 2
IE3-W41B 355 LY4, 6, 8, L4	FF 740	715	729	819	100	80	M24	210	170	28	22	106	85	355	327	1525	1712	1000 A	615	475	385	200	M72 x 2

¹⁾ Centre holes to DIN 332-DS

²⁾ Terminal box left/right

Subject to changes in the course of further development.



VEM  MOTOR

Slip-ring motors

Contents

Product description	6/2
Overview of technical data	6/4
Motor selection data	
Series S..R/SPR variable-speed slip-ring motors, continuous duty S1	6/5
Series S..H/SPH version for crane applications/iron and steel works, duty types S3, S4/S5	6/7
Bearings	6/26
Terminal boxes	6/31
Dimensions	6/34

Product description

Slip-ring motors are still used in many branches of industry, and their particular properties are decisive in determining the efficiency of countless processes. VEM three-phase motors with slip-ring rotor combine the general benefits of this drive solution with VEM's extraordinary manufacturing know-how. Such slip-ring motors

- can be tailored precisely to customer applications thanks to their broad scope of adaptability
- are based on unique technological competence and experience
- have been proven in international use over several decades
- are especially suitable where mains supplies are unstable
- are available in two versions, both with dimensions and frame sizes based on IEC 72
- provide general level-N interference suppression to DIN VDE 0875/DIN EN 55014.

The SPER/S11R/SPEH/S11H series are designed as classic IEC/DIN series, i.e. with mounting dimensions and output assignments in line with DIN 42679/DIN 42681, whereas the SPR/SPH/S10R/S10H provide for more

progressive output assignments compared to the DIN standards, offering outputs up to two steps higher from the same frame size. The motors are equipped with radial fans in plastic or cast aluminium alloy, which cool the motor independently of the latter's direction of rotation (IC 411 to IEC/EN 60034-6). The maximum permissible operating speed is specified in the selection data for hoist motors. In accordance with IEC/EN 60034-1, the motors are subjected to a 2-minute overspeed test at 1.2 times the maximum speed. Special versions of the motors can be supplied for higher maximum speeds.

Upon request, the following motor protection variants are possible:

- Motor protection with PTC thermistor sensors in the stator winding
- Bi-metal temperature sensors as NC and NO contacts in the stator winding
- Resistance thermometers for winding or bearing temperature monitoring
- Space heating to prevent the formation of condensation inside the motor

Function principle and overall design

The function principle and overall design of a slip-ring motor are similar to a squirrel-cage motor. The rotor, however, is provided with a three-phase winding with connections taken out to a slip-ring contact system, rather than with a short-circuited cage winding. As a result, it becomes possible to adapt the rotor circuit (usually by way of a starting resistance) and thus to influence starting and braking response.

The following benefits are obtained:

- With a starting resistance, the starting torque can be varied freely up to the breakdown torque. The starting currents which occur are low (approx. 2 to 3 times the nominal current).

- During steady operation, the speed can be controlled within certain limits (e.g. by switching a resistance).

These benefits define the typical fields of application. Motors with slip-ring rotor are used as a robust alternative to converter-fed motors

- where power supplies are unstable,
- for heavy starting,
- for soft starting,
- for simple speed control where reduced demands are placed on control precision.

The principal fields of application are still today port crane installations and crushers.

Mechanical design

Shaft height	Series	Material			Foot mounting
		Housing	End shields	Feet	
132-250 M, MX4	SPER/SPEH	Grey cast iron			Bolted
250 MX6, 8	S11R/S11H				Cast-on
280, 315	S11R/S11H				Cast-on
132-225	SPR/SPH				Bolted
250, 280	S10R/S10H				Cast-on

Figures 1 and 2 shown the principal components of a VEM slip-ring motor. Regarding the housing components, stator

design, bearings, ventilation and paint finish, please refer to the specifications for VEM standard squirrel-cage motors.

Rotor

Contrary to a squirrel-cage rotor, the rotor winding is here designed as a three-phase winding. The connections are

taken out to the slip-ring contact system. The rotor carries a slip-ring body comprising three rings.

Winding and insulation

The insulation design for the rotor winding of a slip-ring motor corresponds to that of the stator winding on a squirrel-cage motor with regard to the main insulation,

phase insulation, keys and intermediate shields, winding wire and impregnation. The winding overhangs are additionally secured by way of shrink banding.

Slip-ring contact system

The slip-ring body and brush system are arranged either in the slip-ring compartment of the housing at the D-end (sizes 132 to 315 M) or in the end shield at the N-end

(from size 315 MX). The brush holders are double box-type brush holders. The material pairing used for the slip-ring contact system is normally bronze-metal graphite.

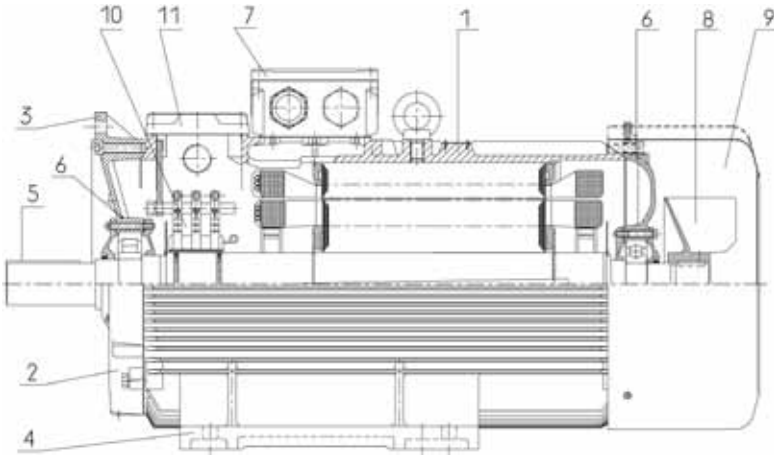

Figure 1: Mechanical design of slip-ring motor S..R/S..H 132 to 315 M

- | | | |
|---------------------|----------------|-----------------------------|
| 1 Housing | 5 Rotor | 9 Fan cowl |
| 2 End shield | 6 Bearings | 10 Slip-ring contact system |
| 3 Flange end shield | 7 Terminal box | 11 Service cover |
| 4 Foot | 8 Fan | |

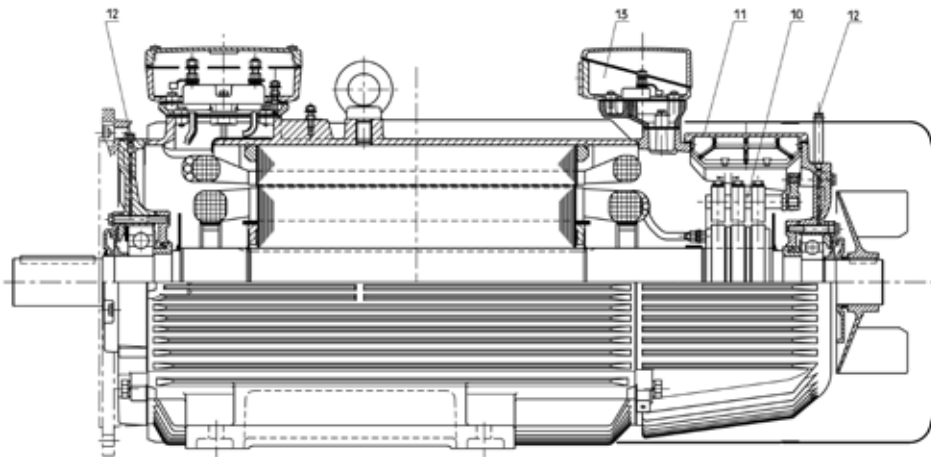

Figure 2: Mechanical design of slip-ring motor S11R/S11H 315 MX-LY

- | | |
|-----------------------------|--|
| 10 Slip-ring contact system | 12 Relubrication facility |
| 11 Service cover | 13 Terminal box for slip-ring contact system |

Overview of technical data

The most important technical data are summarised in the following table. Further information can be taken from the catalogue section "Introduction" (chapter 1).

Product group	Slip-ring rotor, IEC/EN
Rated output	2.2 kW to 315 kW 4 to 10-poles
Sizes	132 to 315
Housing material	Grey cast iron with cast-on motor feet
Rated torque	25 to 2030 Nm
Efficiency classification/ efficiency determination	none / IEC/EN 60034-2
Method of connection	Single-speed motors are designed in star-delta configuration as standard.
Stator winding insulation	Thermal class 155, optional 155 [F(B)] to IEC/EN 60034-1
Degree of protection	IP 55 to IEC/EN 60034-5
Type of cooling	Self-ventilated, IC 411 (series W4.R) to IEC/EN 60034-6
Coolant temperature/ installation altitude	Standard -20 °C to +40 °C, Altitude 1000 m above sea level
Rated voltage	Standard voltages to EN 60038 50 Hz: 230 V, 400 V, 500 V, 690 V 60 Hz: 275 V, 460 V, 480 V, 600 V Voltage range A to IEC/EN 60034-1
Duty types	S1, continuous duty, Duty type S3, 25/40/60/100 % c.d.f. Duty type S4/S5, 150 c/h, 300/600 c/h
Types of construction	IM B3, IM B35, IM B5 and derived types to IEC/EN 60034-7
Paint finish	Normal finish "Moderate", colour RAL 7031, blue-grey Special finish "Worldwide", colour RAL 7031, blue-grey
Vibration severity grade	Grade "A" as standard for machines with no special vibration requirements
Shaft ends	to DIN 748 (IEC 60072), balanced with half-key
Transponder	Optional RFID system iID®2000 (13.56 MHz based on ISO 15693)
Limit speeds	Please refer to the section of "Limit speeds" in catalogue section "Motors for converter-fed operation", Chapter 4.
Bearing design	Please refer to the tables of bearing design data.
Motor mass	Please refer to the technical selection lists.
Terminal boxes	Please refer to the section "Terminal boxes".
Tolerances	Please refer to the section "Tolerances" in catalogue section "Introduction", Chapter 1.
Options	Please refer to the section "Overview of modifications" in catalogue section "Introduction", Chapter 1.
Documentation	An operating and maintenance manual, a terminal plan and a safety data sheet are supplied with each motor.

Motor selection data

Three-phase motors with slip-ring rotor

Series SPER and S11R, duty type S1, continuous duty,
with surface cooling, type of cooling IC 411,
thermal class F, degree of protection IP 54/IP 55

Motor selection data											Design point 400 V, 50 Hz		
Type	P	n	η	$\cos\varphi$	I	Rotor	U	I	M_k/M_B	J	m		
	kW	rpm	%	A	400 V	R	A	A	-	kgm ²	kg		
				-	A	Ω							
Synchronous speed 1500 rpm – 4-pole version													
SPER	132 M4	4	1435	83.0	0.83	8.4	0.1004	130	Y	19	2.8	0.043	85
SPER	132 MX4	5.5	1450	83.0	0.82	11.5	0.1081	170	Y	20	3.4	0.050	95
SPER	160 M4	7.5	1460	86.0	0.83	15.2	0.0922	180	Y	26	3.1	0.093	133
SPER	160 L4	11	1465	87.0	0.83	22.0	0.0979	260	Y	26	4	0.128	150
SPER	180 L4	15	1465	87.5	0.86	29.0	0.0675	250	Y	37	3.6	0.195	204
SPER	200 L4	18.5	1470	89.0	0.86	35.0	0.0346	220	Y	52	3.8	0.330	280
SPER	200 LX4	22	1470	90.0	0.86	41.0	0.0354	255	Y	53	4	0.403	305
SPER	225 M4	30	1475	91.0	0.87	54.5	0.0329	300	Y	62	4.5	0.476	330
SPER	250 M4	37	1475	92.0	0.86	67.5	0.0231	175	Δ	131	4.2	0.568	435
SPER	250 MX4	45	1480	92.2	0.89	79.0	0.0283	210	Δ	132	4.2	0.632	450
S11R	280 S4	55	1480	92.2	0.88	98.0	0.0090	230	Y	148	4	1.250	590
S11R	280 M4	75	1485	92.5	0.86	136	0.0202	290	Δ	160	5	1.850	710
S11R	315 S4	90	1488	93.2	0.88	158	0.0166	280	Δ	199	5.5	2.850	890
S11R	315 M4	110	1488	94.0	0.90	188	0.0171	345	Δ	197	5.2	3.480	1010
S11R	315 MX4	132	1488	94.8	0.90	223	0.0180	410	Δ	199	5.3	5.320	1275
S11R	315 MY4	160	1488	94.9	0.90	270	0.0073	505	Y	196	5.3	5.960	1350
S11R	315 LX4	200	1490	95.5	0.91	332	0.0264	640	Δ	193	5.3	7.290	1540
S11R	315 LY4	250	1490	95.7	0.90	419	0.0273	725	Δ	213	4.5	8.060	1620
Synchronous speed 1000 rpm – 6-pole version													
SPER	132 M6	3	955	79.0	0.77	7.1	0.1180	110	Y	17	2.8	0.050	85
SPER	132 MX6	4	960	80.0	0.76	9.5	0.1249	130	Y	19	3.1	0.063	95
SPER	160 M6	5.5	965	84.0	0.84	11.5	0.1246	170	Y	20	2.4	0.135	133
SPER	160 L6	7.5	965	84.5	0.82	15.5	0.1927	250	Y	19	2.6	0.162	145
SPER	180 L6	11	965	85.0	0.83	22.5	0.0790	205	Y	33	3	0.279	204
SPER	200 L6	15	970	87.0	0.84	29.5	0.0591	230	Y	40	3.2	0.371	280
SPER	225 M6	18.5	975	88.5	0.85	35.5	0.0413	225	Y	51	3.4	0.464	305
SPER	225 MX6	22	980	90.0	0.83	42.5	0.0437	260	Y	52	3.2	0.535	320
SPER	250 M6	30	980	90.5	0.88	54.5	0.0222	125	Δ	148	3.3	1.000	425
S11R	250 MX6	37	985	91.5	0.88	66.5	0.0243	165	Δ	139	3.1	1.610	580
S11R	280 S6	45	985	92.0	0.88	80.0	0.0237	175	Δ	159	3.3	1.820	620
S11R	280 M6	55	985	92.0	0.86	100	0.0220	205	Δ	166	3.9	2.370	710
S11R	315 S6	75	990	94.0	0.88	130	0.0163	235	Δ	197	4	3.900	950
S11R	315 M6	90	990	93.5	0.87	159	0.0173	280	Δ	199	3.2	4.310	1000
S11R	315 MX6	110	987	94.5	0.88	191	0.0070	345	Y	197	3.5	6.800	1290
S11R	315 MY6	132	989	94.8	0.88	224	0.0100	445	Y	183	3.6	8.000	1380
S11R	315 LX6	160	990	95.2	0.89	273	0.0101	515	Y	192	3.5	9.600	1590
Synchronous speed 750 rpm – 8-pole version													
SPER	132 M8	2.2	690	75.0	0.73	5.8	0.1968	100	Y	13.5	2.1	0.048	85
SPER	132 MX8	3.0	705	78.0	0.73	7.6	0.1680	120	Y	15.5	2.2	0.058	95
SPER	160 M8	4.0	720	82.0	0.72	9.8	0.1444	150	Y	16.5	2	0.135	134
SPER	160 L8	5.5	720	82.0	0.72	13.5	0.1472	180	Y	19	2.2	0.163	145
SPER	180 L8	7.5	725	84.0	0.74	17.5	0.1013	185	Y	25	3	0.240	204
SPER	200 L8	11.0	725	86.5	0.78	23.5	0.0831	210	Y	30	2.2	0.362	280
SPER	225 M8	15.0	725	88.0	0.78	31.5	0.0421	190	Y	49	2.8	0.452	305
SPER	225 MX8	18.5	730	88.0	0.79	38.5	0.0484	235	Y	49	2.6	0.568	330
SPER	250 M8	22	732	90.0	0.81	43.5	0.0136	135	Y	101	2.8	0.990	425
S11R	250 MX8	30	735	91.0	0.83	57.5	0.0095	160	Y	116	2.4	1.780	600
S11R	280 S8	37	737	91.0	0.81	72.5	0.0102	180	Y	127	2.8	1.950	660
S11R	280 M8	45	737	92.0	0.78	90.5	0.0112	220	Y	126	2.5	2.370	710
S11R	315 S8	55	740	92.5	0.82	104	0.0096	240	Y	142	2.5	3.950	950
S11R	315 M8	75	738	92.5	0.83	141	0.0399	295	Δ	157	2.3	4.310	1000
S11R	315 MX8	90	742	93.9	0.75	184	0.0066	280	Y	198	3.4	6.800	1290
S11R	315 MY8	110	742	94.1	0.79	214	0.0090	380	Y	179	3.0	8.100	1390
S11R	315 LX8	132	742	94.4	0.80	252	0.0100	440	Y	186	2.7	9.800	1600

Three-phase motors with slip-ring rotor

Series SPR and S10R, progressive output assignment with surface cooling, duty type S1, continuous duty, thermal class F, degree of protection IP 54, 50 Hz

Motor selection data											Design point 400 V, 50 Hz	
Type	P	n	η	$\cos\varphi$	I	R	Rotor	I	M_k/M_B	J	m	
	kW	rpm	%	A	400 V A	Ω	U A	A	-	kgm ²	kg	
Synchronous speed 1500 rpm – 4-pole version												
SPR 132 M4	4.0	1435	83.0	0.83	8.4	0.1670	160 Y	15.5	2.8	0.043	85	
SPR 132 MX4	5.5	1450	83.0	0.82	11.5	0.1380	180 Y	19.0	3.4	0.050	95	
SPR 132 L4	7.5	1450	84.0	0.82	15.5	0.1080	200 Y	23.0	3.1	0.060	105	
SPR 160 M4	11.0	1465	87.0	0.83	22.0	0.0902	250 Y	27.0	4.0	0.128	150	
SPR 160 L4	15.0	1470	87.5	0.82	30.0	0.0702	280 Y	33.0	4.2	0.145	165	
SPR 180 M4	18.5	1470	89.5	0.87	34.5	0.0275	200 Y	57.0	4.3	0.250	225	
SPR 180 L4	22.0	1470	90.5	0.89	39.5	0.0426	270 Y	50.0	4.3	0.285	255	
SPR 200 M4	30.0	1475	91.0	0.87	54.5	0.0156	210 Y	88.0	4.5	0.476	330	
SPR 200 L4	37.0	1480	91.5	0.87	67.0	0.0180	270 Y	85.0	5.0	0.590	375	
SPR 225 M4	45.0	1480	92.2	0.89	79.0	0.0162	280 Y	100.0	4.2	0.632	450	
S10R 250 M4	55.0	1480	92.2	0.88	98.0	0.0168	330 Y	103.0	4.0	1.030	590	
S10R 250 L4	75.0	1485	92.5	0.86	136.0	0.0163	450 Y	103.0	5.0	1.850	710	
S10R 280 M4	90.0	1488	93.2	0.88	158.0	0.0305	400 Δ	139.0	5.5	2.850	890	
S10R 280 L4	110	1488	93.7	0.88	193.0	0.0321	490 Δ	139.0	5.2	3.480	1010	
Synchronous speed 1000 rpm – 6-pole version												
SPR 132 M6	3.0	955	79.0	0.77	7.1	0.1250	120 Y	16.0	2.8	0.050	85	
SPR 132 MX6	4.0	960	80.0	0.76	9.5	0.1410	150 Y	17.0	3.1	0.063	95	
SPR 132 L6	5.5	960	82.0	0.79	12.5	0.1660	180 Y	19.0	2.8	0.078	105	
SPR 160 M6	7.5	965	84.5	0.82	15.5	0.0704	165 Y	28.0	2.6	0.162	145	
SPR 160 L6	11.0	975	85.0	0.80	23.5	0.0526	190 Y	35.0	3.0	0.203	165	
SPR 180 M6	15.0	970	88.0	0.85	29.0	0.0563	220 Y	42.0	3.2	0.315	225	
SPR 180 L6	18.5	975	88.5	0.85	35.5	0.0606	270 Y	42.0	3.5	0.358	255	
SPR 200 M6	22.0	980	90.0	0.83	42.5	0.0165	160 Y	85.0	3.2	0.535	320	
SPR 225 M6	30.0	980	90.5	0.88	54.5	0.0223	230 Y	81.0	3.3	1.000	425	
S10R 250 M6	37.0	985	91.5	0.88	66.5	0.0243	270 Y	85.0	3.1	1.610	580	
S10R 250 MX6	45.0	985	92.0	0.88	80.0	0.0179	280 Y	99.0	3.3	1.820	620	
S10R 280 M6	55.0	987	93.0	0.88	97.0	0.0438	300 Δ	114.0	3.0	3.350	850	
S10R 280 L6	75.0	990	93.5	0.88	132.0	0.0455	400 Δ	116.0	3.6	3.900	950	
Synchronous speed 750 rpm – 8-pole version												
SPR 132 M8	2.2	690	75.0	0.73	5.8	0.1980	100 Y	14.0	2.1	0.048	85	
SPR 132 MX8	3.0	705	78.0	0.73	7.6	0.1680	120 Y	16.0	2.2	0.058	95	
SPR 132 L8	4.0	710	79.0	0.73	10.0	0.1960	150 Y	17.0	2.2	0.068	105	
SPR 160 M8	5.5	720	82.0	0.72	13.5	0.0679	125 Y	28.0	2.2	0.163	145	
SPR 160 L8	7.5	725	84.0	0.74	17.5	0.0526	135 Y	35.0	2.6	0.190	170	
SPR 180 M8	11.0	725	86.0	0.76	24.5	0.0428	150 Y	45.0	2.8	0.308	225	
SPR 180 L8	15.0	730	87.0	0.77	32.5	0.0398	180 Y	51.0	2.9	0.365	260	
SPR 200 M8	18.5	730	88.0	0.79	38.5	0.0164	140 Y	82.0	2.6	0.568	330	
SPR 225 M8	22.0	732	90.0	0.81	43.5	0.0205	180 Y	79.0	2.8	0.990	425	
S10R 250 M8	30.0	735	91.0	0.83	57.5	0.0195	220 Y	84.0	2.4	1.780	600	
S10R 250 L8	37.0	737	91.0	0.81	72.5	0.0209	270 Y	85.0	2.8	1.950	660	
S10R 280 M8	45.0	738	92.0	0.83	85.0	0.0111	220 Y	126.0	2.2	3.300	850	
S10R 280 L8	55.0	740	92.5	0.82	104.7	0.0164	310 Y	110.0	2.5	3.950	950	

Three-phase motors with slip-ring rotor for intermittent periodic duty

Series SPEH and S11H
with surface cooling, duty type S3,
thermal class F, degree of protection IP 54/IP 55

Motor selection data											Design point 400 V, 50 Hz				
Type	S3-	P	n	cos φ	η	I	R	Rotor	I	M _k /M	η _{max}	J	m		
	%	kW	rpm	%	%	400 V A	Ω	U V	A	-	rpm	kgm ²	kg		
Synchronous speed 1500 rpm – 4-pole version															
SPEH 132 M4	100	4.8	1450	0.69	80.0	12.5			18.5	3.4					
	60	5.3	1440	0.72	80.5	13.0			20.5	3.1					
	40	6.3	1430	0.76	80.5	15.0	0.1141	160	Y	24.5	2.6	2500	0.043	85	
	25	7.0	1420	0.79	80.0	16.0			27.0	2.3					
	15	8.0	1410	0.77	80.0	18.7			31.0	2.0					
SPEH 132 MX4	100	5.5	1450	0.76	83.0	12.5			19.0	3.7					
	60	6.6	1440	0.79	83.0	14.5			22.5	3.1					
	40	7.5	1435	0.81	83.0	16.2	0.1168	180	Y	25.5	2.7	2500	0.050	95	
	25	8.7	1425	0.82	82.0	18.7			30.0	2.3					
	15	9.5	1415	0.82	81.0	20.5			32.5	2.1					
SPEH 160 M4	100	7.5	1460	0.80	85.0	16.0			26.0	4.0					
	60	8.5	1455	0.83	85.0	17.5			29.0	3.5					
	40	10.0	1445	0.86	85.0	19.5	0.0792	180	Y	34.5	3.0	2400	0.093	133	
	25	11.0	1440	0.87	84.5	21.5			38.0	2.7					
	15	13.0	1430	0.88	84.0	25.5			44.5	2.3					
SPEH 160 L4	100	11.0	1465	0.75	85.0	25.0			26.0	4.6					
	60	12.5	1460	0.78	85.5	27.0			30.0	4.0					
	40	14.5	1455	0.82	85.5	30.0	0.0919	260	Y	34.5	3.5	2400	0.128	150	
	25	16.5	1450	0.85	85.5	33.0			39.0	3.0					
	15	19.5	1445	0.86	85.0	38.5			46.5	2.6					
SPEH 180 L4	100	15.0	1470	0.72	85.0	35.5			34.5	5.7					
	60	17.0	1465	0.75	85.0	38.5			39.0	5.0					
	40	19.5	1460	0.79	85.5	41.5	0.0639	270	Y	44.5	4.4	2200	0.195	204	
	25	22.0	1455	0.82	86.0	45.0			57.0	3.9					
	15	27.0	1450	0.82	86.0	55.0			62.0	3.2					
SPEH 200 L4	100	18.5	1470	0.82	88.5	37.0			49.5	4.4					
	60	21.0	1465	0.84	89.0	40.5			57.0	3.9					
	40	24.0	1460	0.86	89.0	45.5	0.0344	230	Y	65.0	3.4	2200	0.330	280	
	25	28.0	1455	0.87	88.5	52.5			75.0	2.9					
	15	33.0	1450	0.87	88.0	62.0			89.0	2.5					
SPEH 200 LX4	100	22.0	1475	0.87	90.0	40.5			49.5	4.2					
	60	25.0	1470	0.88	90.0	45.5			56.0	3.7					
	40	28.0	1465	0.89	90.0	50.5	0.0377	275	Y	63.0	3.3	2200	0.403	305	
	25	33.0	1460	0.90	90.0	59.0			74.0	2.8					
	15	40.0	1455	0.89	89.0	73.0			90.0	2.3					
SPEH 225 M4	100	30	1475	0.83	90.0	58.0			56	4.9					
	60	34	1470	0.85	90.0	64.0			64	4.3					
	40	39	1465	0.87	90.0	72.0	0.0367	330	Y	73	3.8	2200	0.476	330	
	25	45	1460	0.88	90.0	82.0			84	3.3					
	15	53	1455	0.89	89.0	96.5			99	2.8					
SPEH 250 M4	100	37	1482	0.84	92.0	69.0			117	4.5					
	60	42	1478	0.85	92.0	77.5			133	4.0					
	40	48	1475	0.86	92.0	87.5	0.0083	195	Y	152	3.5	2200	0.568	425	
	25	55	1472	0.88	91.5	99.0			174	3.0					
	15	65	1467	0.88	91.0	117			206	2.6					

Three-phase motors with slip-ring rotor for intermittent periodic duty

Series SPEH and S11H
with surface cooling, duty type S3,
thermal class F, degree of protection IP 54/IP 55

Motor selection data												Design point 400 V, 50 Hz			
Type		S3- %	P kW	n rpm	cos φ	η %	I 400 V A	R Ω	Rotor U V		I A	M _k /M _B -	n _{max} rpm	J kgm ²	m kg
Synchronous speed 1500 rpm – 4-pole version															
SPEH	250 MX4	100	45	1480	0.86	91.8	82.5				118	4.2			
		60	51	1477	0.88	91.8	91.5				134	3.7			
		40	58	1475	0.89	91.8	103	0.0105	235	Y	152	3.3	2200	0.632	450
		25	67	1470	0.90	91.5	117				176	2.8			
		15	80	1465	0.92	91.1	138				210	2.4			
S11H	280 S4	100	60	1480	0.84	92.0	112				154	4.0			
		60	68	1475	0.86	92.0	124				175	3.5			
		40	75	1475	0.87	92.0	135	0.0086	240	Y	193	3.2	2200	1.25	590
		25	90	1470	0.89	92.0	159				232	2.7			
		15	105	1465	0.89	91.5	186				270	2.3			
S11H	280 M4	100	75	1486	0.81	92.3	145				149	5.7			
		60	85	1484	0.83	92.6	160				169	5.0			
		40	95	1483	0.85	92.8	174	0.0239	310	Δ	189	4.6	2200	1.85	710
		25	110	1480	0.86	92.8	199				219	3.9			
		15	132	1478	0.88	92.8	233				263	3.2			
S11H	315 S4	100	90	1488	0.88	93.5	158				179	5.8			
		60	100	1487	0.89	93.5	173				199	5.3			
		40	115	1485	0.91	93.7	195	0.0177	310	Δ	229	4.6	2200	2.85	890
		25	132	1483	0.92	93.7	221				263	4.0			
		15	160	1479	0.92	93.5	268				319	3.3			
S11H	315 M4	100	110	1485	0.91	94.2	185				181	5.4			
		60	125	1483	0.92	94.3	208				206	4.8			
		40	140	1482	0.93	94.3	230	0.0210	375	Δ	231	4.3	2200	3.48	1010
		25	160	1480	0.93	94.2	264				264	3.7			
		15	190	1475	0.94	94.1	310				313	3.1			
S11H	315 MX4	100	132	1488	0.90	94.8	223				199	5.3			
		60	150	1486	0.90	94.9	253				226	4.6			
		40	165	1484	0.91	94.8	276	0.0180	410	Δ	249	4.2	2200	5.32	1275
		25	190	1482	0.92	94.7	315				286	3.6			
		15	225	1479	0.92	94.6	373				339	3.1			
S11H	315 MY4	100	160	1488	0.90	94.9	270				196	5.3			
		60	180	1486	0.90	94.9	304				220	4.7			
		40	200	1485	0.91	94.9	334	0.0073	505	Y	245	4.2	2200	5.96	1350
		25	230	1483	0.92	94.9	380				281	3.7			
		15	270	1481	0.94	94.9	437				330	3.1			
S11H	315 LX4	100	200	1490	0.91	95.5	332				193	5.3			
		60	225	1489	0.92	95.5	370				217	4.7			
		40	250	1487	0.92	95.5	411	0.0264	640	Δ	241	4.2	2200	7.29	1540
		25	290	1486	0.92	95.3	477				280	3.6			
		15	340	1484	0.92	95.2	560				328	3.1			
S11H	315 LY4	100	250	1488	0.90	95.7	419				213	4.5			
		60	280	1485	0.91	95.6	465				234	4.0			
		40	315	1482	0.91	95.5	523	0.0273	725	Δ	260	3.6	2200	8.06	1620
		25	360	1479	0.90	95.3	606				302	3.1			
		15	430	1472	0.90	94.7	728				362	2.6			

Three-phase motors with slip-ring rotor for intermittent periodic duty

Series SPEH and S11H
with surface cooling, duty type S3,
thermal class F, degree of protection IP 54/IP 55

Motor selection data											Design point 400 V, 50 Hz				
Type	S3-	P	n	cos φ	η	I	R	Rotor	I	M _k /M _B	n _{max}	J	m		
	%	kW	rpm	%	%	400 V A	Ω	U V	A	-	rpm	kgm ²	kg		
Synchronous speed 1000 rpm – 6-pole version															
SPEH 132 M6	100	3.5	945	0.71	74.0	9.6			18	3.1					
	60	3.9	940	0.74	74.5	10.5			20	2.7					
	40	4.5	930	0.77	74.0	11.5	0.1180	120	Y	23	2.4	2500	0.050	85	
	25	5	920	0.80	74.0	12.5			26	2.1					
	15	6	915	0.80	73.5	14.7			31	1.8					
SPEH 132 MX6	100	4	965	0.74	79.0	9.9			17.5	3.7					
	60	4.8	955	0.77	79.0	11.4			21	3.1					
	40	5.5	950	0.80	79.0	12.5	0.1151	140	Y	24.5	2.7	2500	0.063	95	
	25	6.5	940	0.82	79.0	14.5			28.5	2.3					
	15	7	925	0.83	78.0	15.5			31	2.1					
SPEH 160 M6	100	5.5	973	0.67	81.0	14.5			19	4.2					
	60	6	970	0.70	81.5	15.0			20.5	3.8					
	40	7	965	0.74	82.0	16.5	0.1097	180	Y	24	3.3	2400	0.135	133	
	25	8	960	0.78	82.0	18.0			27.5	2.9					
	15	9.5	955	0.80	82.0	21.0			32.5	2.4					
SPEH 160 L6	100	7.5	972	0.73	82.0	18.0			18	3.8					
	60	8.5	970	0.76	83.0	19.5			20	3.4					
	40	10	965	0.80	83.0	21.5	0.1600	260	Y	24	2.9	2400	0.162	165	
	25	11.5	960	0.82	83.0	24.5			27.5	2.5					
	15	13.5	950	0.84	82.0	28.5			32	2.1					
SPEH 180 L6	100	11	968	0.78	84.0	24.5			29.5	3.8					
	60	12.5	962	0.81	84.0	26.5			33.5	3.3					
	40	14.5	957	0.84	84.0	29.5	0.0959	230	Y	39	2.9	2200	0.279	204	
	25	16.5	950	0.85	83.5	33.5			44.5	2.5					
	15	21	940	0.85	83.0	43.0			57	2.0					
SPEH 200 L6	100	15	973	0.79	86.5	31.5			36.5	3.6					
	60	17.5	968	0.82	86.5	35.5			42.5	3.1					
	40	20	963	0.84	86.0	40.0	0.0754	255	Y	48.5	2.7	2080	0.371	280	
	25	23	957	0.85	85.5	45.5			56	2.3					
	15	28	950	0.86	85.0	55.5			68	1.9					
SPEH 225 M6	100	18.5	978	0.77	87.5	39.5			46	4.3					
	60	22	973	0.81	87.5	45.0			55	3.6					
	40	25	970	0.83	87.5	49.5	0.0499	250	Y	62	3.2	2080	0.464	305	
	25	28	965	0.84	87.0	55.5			69	2.8					
	15	35	960	0.85	87.0	68.5			87	2.2					
SPEH 225 MX6	100	22	980	0.82	88.0	39.0			47	3.9					
	60	26	975	0.84	88.0	44.0			56	3.3					
	40	30	970	0.85	88.0	58.0	0.0561	290	Y	64	2.9	2080	0.535	320	
	25	34	965	0.87	88.0	65.5			73	2.5					
	15	42	960	0.88	87.0	79.0			90	2.0					
SPEH 250 M6	100	27	980	0.83	89.0	52.5			119	4.2					
	60	32	980	0.84	89.0	61.5			141	3.6					
	40	37	980	0.85	89.0	70.5	0.0103	140	Y	163	3.1	2080	1.00	425	
	25	42	975	0.86	89.0	79.0			185	2.7					
	15	55	965	0.87	89.0	103			243	2.1					

Three-phase motors with slip-ring rotor for intermittent periodic duty

Series SPEH and S11H
with surface cooling, duty type S3,
thermal class F, degree of protection IP 54/IP 55 55

Motor selection data											Design point 400 V, 50 Hz				
Type	S3-	P	n	cos φ	η	I	R	Rotor		I	M _K /M _B	n _{max}	J	m	
	%	kW	rpm	%	%	400 V A	Ω	U V		A	-	rpm	kgm ²	kg	
Synchronous speed 1000 rpm – 6-pole version															
S11H	250 MX6	100	34	987	0.82	90.0	66.5			120	4.4				
		60	39	985	0.85	90.0	73.5			138	3.8				
		40	45	985	0.86	90.0	83.5	0.0261	175	Δ	159	3.3	2080	1.61	580
		25	52	980	0.87	90.0	96.0				184	2.8			
		15	70	974	0.88	90.0	126.0				247	2.1			
S11H	280 S6	100	45	987	0.81	91.0	88.0			146	4.2				
		60	52	985	0.83	91.0	99.5			169	3.7				
		40	60	982	0.85	91.0	112	0.0248	190	Δ	195	3.2	2080	1.82	600
		25	70	979	0.86	91.0	129				228	2.7			
		15	85	975	0.86	90.0	159				276	2.2			
S11H	280 M6	100	55	986	0.84	92.5	102			144	4.0				
		60	64	983	0.86	92.5	116			168	3.4				
		40	75	980	0.87	92.3	135	0.0273	235	Δ	197	2.9	2080	2.37	700
		25	85	978	0.88	92.1	151				223	2.5			
		15	105	975	0.88	91.8	188				276	2.1			
S11H	315 S6	100	75	990	0.82	92.5	143			178	4.1				
		60	87	988	0.84	92.5	162			207	3.6				
		40	100	987	0.86	92.5	181	0.0175	260	Δ	238	3.1	2080	3.95	950
		25	115	985	0.87	92.5	206				273	2.7			
		15	130	983	0.87	92.5	235				309	2.4			
S11H	315 M6	100	90	988	0.85	92.5	165			180	4.0				
		60	105	986	0.87	92.6	188			209	3.4				
		40	120	984	0.88	92.5	213	0.0241	310	Δ	239	3.0	2080	4.31	1000
		25	140	981	0.88	92.2	249				279	2.5			
		15	165	978	0.88	91.5	296				329	2.1			
S11H	315 MX6	100	110	987	0.87	94.4	193			197	3.5				
		60	125	986	0.88	94.3	217			224	3.1				
		40	140	984	0.89	94.1	241	0.0070	345	Y	251	2.7	2080	6.8	1290
		25	160	982	0.89	94.0	276				286	2.4			
		15	190	980	0.89	93.6	329				340	2.0			
S11H	315 MY6	100	132	989	0.88	94.8	228			183	3.6				
		60	150	987	0.88	94.6	260			208	3.1				
		40	170	986	0.88	94.4	295	0.0100	445	Y	236	2.8	2080	8.0	1380
		25	195	984	0.87	94.0	344				271	2.4			
		15	230	981	0.86	93.0	415				319	2.0			
S11H	315 LX6	100	160	990	0.89	95.2	273			192	3.5				
		60	185	989	0.89	95.1	315			222	3.0				
		40	210	988	0.89	95.0	358	0.0101	515	Y	252	2.6	2080	9.6	1590
		25	240	986	0.89	94.6	411				288	2.3			
		15	280	983	0.88	93.5	491				336	2.0			

Three-phase motors with slip-ring rotor for intermittent periodic duty

Series SPEH and S11H
with surface cooling, duty type S3,
thermal class F, degree of protection IP 54/IP 55

Motor selection data											Design point 400 V, 50 Hz				
Type	S3-	P	n	cos φ	η	I	R	Rotor	I	M _k /M _B	n _{max}	J	m		
	%	kW	rpm	%	%	400 V A	Ω	U V	A	-	rpm	kgm ²	kg		
Synchronous speed 750 rpm – 8-pole version															
SPEH 132 M8	100	2.3	710	0.62	70.0	7.6				2.9					
	60	2.8	700	0.68	70.0	8.5				2.3					
	40	3.3	685	0.72	70.0	9.5	0.3030	145	Y	15.0	2.0	2500	0.048	85	
	25	3.3	685	0.72	70.0	9.5				15.0	2.0				
SPEH 132 MX8	100	3.0	710	0.62	74.0	9.4				3.0					
	60	3.6	700	0.67	74.0	10.5				2.5					
	40	4.3	690	0.72	74.0	12.0	0.2800	160	Y	16.5	2.0	2500	0.058	95	
	25	4.9	680	0.74	74.0	13.0				19.0	1.8				
SPEH 160 M8	100	3.6	725	0.59	79.0	11.0				3.0					
	60	4.5	720	0.65	80.0	12.5				2.4					
	40	5.3	714	0.70	80.0	13.5	0.1980	190	Y	17.5	2.1	2400	0.135	133	
	25	6.0	707	0.73	79.5	15.0				19.5	1.8				
SPEH 160 L8	100	5.5	730	0.58	79.0	17.3				3.3					
	60	6.0	725	0.64	79.0	17.1				3.0					
	40	7.2	720	0.69	79.0	19.0	0.1590	200	Y	21.5	2.6	2400	0.162	145	
	25	8.0	715	0.72	79.0	20.5				25.0	2.3				
SPEH 180 L8	100	7.5	725	0.66	82.0	20.0				3.7					
	60	8.5	720	0.70	82.5	21.5				3.3					
	40	10.0	715	0.74	82.5	23.5	0.1312	210	Y	29.5	2.8	2200	0.279	204	
	25	11.5	710	0.78	82.0	26.0				34.0	2.4				
SPEH 200 L8	100	11.0	728	0.68	84.0	28.0				3.5					
	60	12.5	725	0.71	84.0	30.5				3.1					
	40	14.5	720	0.74	84.0	33.5	0.0977	250	Y	36	2.7	1875	0.279	280	
	25	16.5	715	0.77	83.5	37.0				41	2.4				
SPEH 225 M8	100	15.0	728	0.66	86.0	38.0				3.6					
	60	17.5	725	0.70	86.0	42.0				3.1					
	40	20.0	720	0.73	85.5	47.0	0.0526	220	Y	56	2.7	1875	0.464	305	
	25	23.0	715	0.76	85.0	51.5				65	2.3				
SPEH 225 MX8	100	18.5	735	0.68	87.0	45.0				3.8					
	60	22.0	730	0.72	87.0	50.5				3.2					
	40	25.0	730	0.75	87.0	55.5	0.0606	270	Y	57	2.8	1875	0.568	330	
	25	28.0	725	0.77	87.0	60.5				64	2.5				
SPEH 250 M8	100	22	735	0.72	88.0	50.0				3.5					
	60	26	730	0.75	88.0	57.0				3.0					
	40	30	725	0.79	88.0	62.5	0.0134	150	Y	124	2.6	1875	1.00	425	
	25	34	725	0.80	88.0	70.0				140	2.3				
SPEH 250 M8	15	42	720	0.81	87.0	86.0				1.9					
										173	1.9				

Three-phase motors with slip-ring rotor for intermittent periodic duty

Series SPEH and S11H
with surface cooling, duty type S3,
thermal class F, degree of protection IP 54/IP 55

Motor selection data											Design point 400 V, 50 Hz				
Type	S3-	P	n	cos φ	η	I	R	Rotor	I	M _k /M _B	n _{max}	J	m		
	%	kW	rpm		%	400 A	Ω	U V	A	-	rpm	kgm ²	kg		
Synchronous speed 750 rpm – 8-pole version															
S11H	250 MX8	100	27	740	0.77	90.0	56.0			88	3.4				
		60	32	737	0.78	90.0	66.0			104	2.9				
		40	37	735	0.79	90.0	75.0	0.0409	190	Δ	120	2.5	1875	1.78	600
		25	42	733	0.80	90.0	84.0				137	2.2			
		15	55	728	0.80	90.0	110				179	1.7			
S11H	280 S8	100	37	738	0.68	90.7	86.5			114	3.5				
		60	44	736	0.71	90.8	98.5			136	2.9				
		40	50	734	0.74	90.6	108	0.0328	200	Δ	154	2.6	1875	1.95	665
		25	57	732	0.76	90.2	120				176	2.3			
		15	70	730	0.78	89.9	144				216	1.9			
S11H	280 M8	100	45	740	0.69	91.3	103			111	3.6				
		60	55	737	0.74	91.3	118			136	3.0				
		40	63	735	0.77	91.2	130	0.0416	250	Δ	156	2.6	1875	2.37	710
		25	73	732	0.79	90.8	147				180	2.2			
		15	90	726	0.79	90.0	183				222	1.8			
S11H	315 S8	100	60	740	0.76	92.5	123			130	3.4				
		60	70	739	0.79	92.5	138			152	2.9				
		40	80	737	0.80	92.2	157	0.0317	285	Δ	173	2.5	1875	3.95	950
		25	93	735	0.82	91.7	179				202	2.2			
		15	105	733	0.82	90.5	204				228	1.9			
S11H	315 M8	100	75	740	0.77	91.9	153			129	3.1				
		60	88	738	0.80	91.8	173			151	2.6				
		40	100	735	0.80	91.5	197	0.0437	360	Δ	172	2.3	1875	4.31	1000
		25	115	732	0.81	91.0	225				198	2.0			
		15	140	730	0.81	90.0	277				240	1.6			
S11H	315 MX8	100	90	742	0.76	93.9	182			198	3.4				
		60	105	740	0.78	93.8	207			232	2.9				
		40	115	739	0.80	93.7	221	0.0066	280	Y	254	2.6	1875	6.8	1290
		25	140	736	0.81	93.2	268				309	2.2			
		15	160	733	0.81	92.5	308				353	1.9			
S11H	315 MY8	100	110	742	0.79	94.1	214			179	3.0				
		60	125	741	0.81	94.1	237			203	2.7				
		40	140	740	0.82	94.0	262	0.0090	380	Y	228	2.4	1875	8.1	1390
		25	160	739	0.83	93.7	297				260	2.1			
		15	190	735	0.82	92.5	362				309	1.8			
S11H	315 LX8	100	132	742	0.80	94.4	252			186	2.7				
		60	150	740	0.80	94.2	287			211	2.4				
		40	170	739	0.80	93.8	327	0.0100	440	Y	239	2.1	1875	9.8	1600
		25	195	737	0.81	93.4	372				274	1.8			
		15	220	735	0.81	93.3	420				309	1.6			

Three-phase motors with slip-ring rotor for intermittent periodic duty

Series SPEH and S11H
with surface cooling, duty type S3,
thermal class F, degree of protection IP 54/IP 55

Motor selection data											Design point 400 V, 50 Hz				
Type	S3-	P	n	cos φ	η	I	R	Rotor	I	M _k /M _B	n _{max}	J	m		
	%	kW	rpm	%	%	400 V A	Ω	U V	A	-	rpm	kgm ²	kg		
Synchronous speed 600 rpm – 10-pole version															
SPEH	250 M10	100	16.5	590	0.56	86.0	49.5			82	3.4				
		60	20.0	585	0.63	86.0	53.5			99	2.8				
		40	23.0	580	0.66	86.0	58.5	0.0113	125	Y	114	2.4	2000	0.937	425
		25	26.0	580	0.67	86.0	65.0			129	2.1				
		15	30.0	575	0.67	86.0	75.0			148	1.8				
S11H	250 MX10	100	20	590	0.52	84.5	66.0			82	3.6				
		60	24	587	0.57	85.0	71.0			99	2.8				
		40	28	585	0.62	86.0	76.0	0.0366	150	Δ	115	2.4	2000	1.61	580
		25	32	580	0.65	86.0	83.0			132	2.1				
		15	35	578					144	1.9					
S11H	280 S10	100	27	589	0.49	85.0	94.0			104	3.2				
		60	32	587	0.56	86.0	96.0			124	2.7				
		40	37	585	0.59	86.0	105	0.0282	160	Δ	143	2.3	2000	1.82	600
		25	42	580	0.63	86.0	112			162	2.0				
		15	48	575	0.67	87.0	149			185	1.7				
S11H	280 M10	100	35	589	0.55	86.0	107			111	2.9				
		60	42	587	0.60	87.0	116			133	2.4				
		40	48	585	0.64	87.0	124	0.0331	195	Δ	152	2.1	1500	2.37	710
		25	55	583	0.67	87.0	136			174	1.9				
		15	60	580					190	1.7					
S11H	315 S10	100	44	590	0.58	89.5	122			116	3.1				
		60	52	586	0.63	89.5	133			137	2.6				
		40	60	585	0.65	89.5	143	0.0383	235	Δ	158	2.2	1500	3.95	1000
		25	70	584	0.66	89.0	172			184	1.9				
		15	75	584	0.68	88.5	180			197	1.7				
S11H	315 M10	100	55	590	0.58	88.7	154			119	3.0				
		60	65	588	0.63	88.7	168			141	2.5				
		40	75	586	0.65	88.7	188	0.0395	285	Δ	163	2.1	1500	4.31	1050
		25	87	585	0.66	88.5	215			189	1.8				
		15	90	584	0.67	88.0	220								
S11H	315 MX10	100	70	589	0.60	91.0	185			160	2.7				
		60	80	588	0.64	91.0	198			183	2.3				
		40	90	587	0.66	91.0	216	0.0099	270	Y	206	2.1	1500	6.8	1290
		25	100	585	0.68	90.8	234			229	1.9				
S11H	315 MY10	100	80	593	0.64	92.3	196			157	2.9				
		60	90	592	0.67	92.3	210			177	2.6				
		40	100	590	0.68	92.3	230	0.0258	315	Δ	196	2.3	1500	8.1	1390
		25	120	588	0.68	91.5	280			235	1.9				
S11H	315 LX10	100	90	592	0.66	92.7	212			159	2.6				
		60	105	590	0.69	92.6	237			185	2.2				
		40	115	589	0.71	92.4	253	0.0310	350	Δ	203	2.0	1500	9.8	1600
		25	135	585	0.72	91.0	297			238	1.7				

Three-phase motors with slip-ring rotor for intermittent periodic duty

Series SPEH and S11H
 with surface cooling, duty type S4 and S5, mean starting torque $M_A = 1.5 \cdot M_N$
 thermal class F, degree of protection IP 54/IP 55

Motor selection data										Design point 400 V, 50 Hz		
Type	S4/S5- %	c/h	P kW	n rpm	R Ω	Rotor U V	I A	M_K/M_B -	J_{Motor} kgm ²	$J_{ext.}$ kgm ²	m kg	
Synchronous speed 1500 rpm – 4-pole version												
SPEH 132 M4	60	150	4.8	1450			18.5	3.4				
	40	150	5.8	1440			22.2	2.8				
	25	150	6.4	1430	0.1141	160	Y	24.7	2.6	0.043	0.086	85
	60	300	4.1	1455			15.9	4.0				
	40	300	4.8	1450			18.5	3.4				
SPEH 132 MX4	60	600	3.2	1475			12.2	5.2				
	60	150	5.5	1450			18.9	3.7				
	40	150	6.6	1440			22.7	3.1				
	25	150	7.3	1435	0.1168	180	Y	25.0	2.8	0.050	0.100	95
	60	300	4.7	1455			16.2	4.3				
SPEH 160 M4	40	300	5.5	1450			18.9	3.7				
	60	600	3.6	1470			12.5	5.6				
	60	150	7.5	1460			25.5	4.0				
	40	150	9.0	1450			31.0	3.3				
	25	150	10.0	1445	0.0792	180	Y	34.5	3.0	0.093	0.186	133
SPEH 160 L4	60	300	6.5	1465			22.1	4.7				
	40	300	7.5	1460			25.5	4.0				
	60	600	5.0	1470			17.0	6.1				
	60	150	11.0	1465			26.0	4.6				
	40	150	13.2	1460			31.5	3.8				
SPEH 180 L4	25	150	14.7	1455			35.0	3.5				
	60	300	9.5	1470	0.0919	260	Y	22.5	5.3	0.128	0.256	150
	40	300	11.0	1465			26.0	4.6				
	60	600	7.3	1478			17.2	7.0				
	60	150	15.0	1470			34.5	4.6				
SPEH 200 L4	40	150	18.0	1465			41.0	3.8				
	25	150	20.0	1460	0.0639	270	Y	45.5	3.5	0.195	0.351	204
	60	300	12.9	1475			29.5	5.3				
	40	300	15.0	1470			34.5	4.6				
	60	600	9.9	1477			22.7	7.0				
SPEH 200 LX4	60	150	18.5	1470			49.5	4.4				
	40	150	22.0	1465			60.0	3.7				
	25	150	24.5	1460	0.0344	230	Y	66.0	3.3	0.330	0.561	280
	60	300	16.0	1473			42.5	5.1				
	40	300	18.5	1470			49.5	4.4				
SPEH 225 M4	60	600	12.0	1478			33.0	6.8				
	60	150	22.0	1475			49.5	4.2				
	40	150	26.6	1470			59.5	3.5				
	25	150	29.0	1465	0.0377	275	Y	66.0	3.2	0.403	0.605	305
	60	300	19.0	1477			42.7	4.9				
SPEH 250 M4	40	300	22.0	1475			49.5	4.2				
	60	600	14.5	1482			32.5	6.4				
	60	150	30.0	1475			56.0	4.9				
	40	150	36.0	1460			67.5	4.1				
	25	150	40.0	1465	0.0367	330	Y	75.0	3.7	0.476	0.714	330
SPEH 250 M4	60	300	26.0	1480			48.5	5.7				
	40	300	30.0	1475			56.0	4.9				
	60	600	20.0	1485			37.0	7.4				
	60	150	37	1482			117	4.5				
	40	150	44.5	1478			141	3.7				
SPEH 250 M4	25	150	49.5	1475	0.0083	195	Y	157	3.4	0.568	0.795	425
	60	300	32.0	1485			101	5.2				
	40	300	37.0	1482			117	4.5				
	60	600	24.5	1490			78	6.8				

Three-phase motors with slip-ring rotor for intermittent periodic duty

Series SPEH and S11H
 with surface cooling, duty type S4 and S5, mean starting torque $M_A = 1.5 \cdot M_N$
 thermal class F, degree of protection IP 54/IP 55

Motor selection data										Design point 400 V, 50 Hz			
Type		S4/S5-	c/h	P	n	R	Rotor	I	M_K/M_B	J_{Motor}	$J_{ext.}$	m	
		%		kW	rpm	Ω	U V	A	-	kgm ²	kgm ²	kg	
Synchronous speed 1500 rpm – 4-pole version													
SPEH	250 MX4	60	150	45.0	1480			118	4.2				
		40	150	54.0	1477			142	3.5				
		25	150	60.0	1475	0.0105	235	Y	158	3.2	0.632	0.758	450
		60	300	38.5	1484			101	4.9				
		40	300	45.0	1480			118	4.2				
		60	600	29.5	1486			78	6.4				
S11H	280 S4	60	150	60	1480			154	4.0				
		40	150	72	1477			185	3.3				
		25	150	80	1473	0.0086	240	Y	206	3.0	1.25	1.25	590
		60	300	51	1484			131	4.7				
		40	300	60	1480			154	4.0				
		60	600	40	1486			103	6.0				
S11H	280 M4	60	150	75	1486			149	5.2				
		40	150	90	1484			179	4.3				
		25	150	100	1482	0.0239	310	Δ	199	3.9	1.85	1.85	710
		60	300	65	1488			129	6.0				
		40	300	75	1486			149	5.2				
		60	600	50	1490			99	7.9				
S11H	315 S4	60	150	90	1488			179	5.8				
		40	150	108	1486			215	4.8				
		25	150	120	1484	0.0177	310	Δ	239	4.4	2.85	2.00	890
		60	300	77	1490			154	6.7				
		40	300	90	1488			179	5.8				
		60	600	59	1492			118	8.8				
S11H	315 M4	60	150	110	1485			181	5.4				
		40	150	132	1483			217	4.5				
		25	150	147	1481	0.0210	375	Δ	242	4.1	3.48	2.44	1010
		60	300	95	1488			156	6.3				
		40	300	110	1485			181	5.4				
		60	600	73	1492			120	8.2				
S11H	315 MX4	60	150	132	1488			199	5.3				
		40	150	158	1486			239	4.4				
		25	150	176	1484	0.0180	410	Δ	265	4.0	5.32	2.66	1275
		60	300	114	1489			171	6.2				
		40	300	132	1488			199	5.3				
		60	600	87	1492			131	8.0				
S11H	315 MY4	60	150	160	1488			196	5.3				
		40	150	192	1485			235	4.4				
		25	150	213	1484	0.0073	505	Y	261	4.0	5.96	2.68	1350
		60	300	138	1489			168	6.2				
		40	300	160	1488			196	5.3				
		60	600	106	1492			129	8.0				
S11H	315 LX4	60	150	200	1490			193	5.3				
		40	150	240	1488			232	4.4				
		25	150	267	1487	0.0264	640	Δ	257	4.0	7.29	2.92	1540
		60	300	172	1491			166	6.2				
		40	300	200	1490			193	5.3				
		60	600	132	1493			127	8.0				
S11H	315 LY4	60	150	250	1488			213	4.5				
		40	150	300	1483			256	3.8				
		25	150	333	1480	0.0273	725	Δ	284	3.4	8.06	3.22	1620
		60	300	215	1490			183	5.2				
		40	300	250	1488			213	4.5				
		60	600	165	1492			141	6.8				

Three-phase motors with slip-ring rotor for intermittent periodic duty

Series SPEH and S11H
 with surface cooling, duty type S4 and S5, mean starting torque $M_A = 1.5 * M_N$
 thermal class F, degree of protection IP 54/IP 55

Motor selection data										Design point 400 V, 50 Hz		
Type	S4/S5-	c/h	P	n	R	Rotor	I	M_K/M_B	J_{Motor}	$J_{ext.}$	m	
	%		kW	rpm	Ω	U V	A	-	kgm ²	kgm ²	kg	
Synchronous speed 1000 rpm – 6-pole version												
SPEH 132 M6	60	150	3.5	945			18.0	3.1				
	40	150	4.2	938			21.6	2.6				
	25	150	4.7	930	0.1180	120	Y	24.0	2.3	0.050	0.100	85
	60	300	3.0	950			15.5	3.6				
	40	300	3.5	945			18.0	3.1				
SPEH 132 MX6	60	600	2.3	960			11.9	4.7				
	60	150	4.0	965			17.7	3.7				
	40	150	4.8	955			21.2	3.1				
	25	150	5.3	950	0.1151	140	Y	23.5	2.8	0.063	0.126	95
	60	300	3.4	970			15.2	4.3				
SPEH 160 M6	40	300	4.0	965			17.7	3.7				
	60	600	2.6	973			11.6	5.6				
	60	150	5.5	973			18.9	4.2				
	40	150	6.6	967			22.7	3.5				
	25	150	7.3	963	0.1097	180	Y	25.0	3.2	0.135	0.270	133
SPEH 160 L6	60	300	4.7	977			16.2	4.9				
	40	300	5.5	973			18.9	4.2				
	60	600	3.6	982			12.5	6.4				
	60	150	7.5	972			17.8	3.8				
	40	150	9.0	967			21.4	3.2				
SPEH 180 L6	25	150	10.0	965	0.1600	260	Y	23.8	2.9	0.162	0.324	165
	60	300	6.5	976			15.3	4.4				
	40	300	7.5	972			17.8	3.8				
	60	600	5.0	980			11.8	5.8				
	60	150	11.0	968			29.5	3.8				
SPEH 200 L6	40	150	13.2	960			35.5	3.2				
	25	150	14.7	957	0.0959	230	Y	39.5	2.9	0.279	0.558	204
	60	300	9.5	972			25.5	4.4				
	40	300	11.0	968			29.5	3.8				
	60	600	7.3	983			19.5	5.8				
SPEH 225 M6	60	150	15	973			36.5	3.6				
	40	150	18.0	967			43.5	3.0				
	25	150	20.0	963	0.0754	255	Y	48.5	2.7	0.371	0.742	280
	60	300	12.9	977			31.5	4.2				
	40	300	15.0	973			36.5	3.6				
SPEH 225 MX6	60	600	9.9	982			24.0	5.5				
	60	150	18.5	978			45.5	4.3				
	40	150	22.2	973			55.0	3.6				
	25	150	24.7	970	0.0499	250	Y	61.0	3.2	0.464	0.928	305
	60	300	15.9	981			39.5	5.0				
SPEH 250 M6	40	300	18.5	978			45.5	4.3				
	60	600	12.2	986			30.0	6.5				
	60	150	22.0	980			47.0	3.9				
	40	150	26.5	975			56.0	3.2				
	25	150	29.0	970	0.0561	290	Y	62.0	3.0	0.535	1.07	320
SPEH 250 MX6	60	300	19.0	982			40.5	4.5				
	40	300	22.0	980			47.0	3.9				
	60	600	14.5	985			31.0	5.9				
	60	150	27.0	980			119	4.2				
	40	150	32.0	980			141	3.5				
SPEH 250 M6	25	150	36.0	980	0.0103	140	Y	159	3.2	1.00	1.50	425
	60	300	23.0	984			101	4.9				
	40	300	27.0	980			119	4.2				
	60	600	17.0	988			75	6.7				

Three-phase motors with slip-ring rotor for intermittent periodic duty

Series SPEH and S11H
 with surface cooling, duty type S4 and S5, mean starting torque $M_A = 1.5 * M_N$
 thermal class F, degree of protection IP 54/IP 55

Motor selection data		Design point 400 V, 50 Hz											
Type		S4/S5-	c/h	P	n	R	Rotor		I	M_K/M_B	J_{Motor}	$J_{ext.}$	m
		%		kW	rpm	Ω	U V		A	-	kgm ²	kgm ²	kg
Synchronous speed 1000 rpm – 6-pole version													
S11H	250 MX6	60	150	34.0	987				120	4.4			
		40	150	40.0	986				141	3.7			
		25	150	45.0	985	0.0261	175	Δ	159	3.3	1.61	2.25	580
		60	300	29.0	988				102	5.2			
		40	300	34.0	987				120	4.4			
		60	600	22.0	990				78	6.8			
S11H	280 S6	60	150	45	987				146	4.2			
		40	150	54	984				176	3.5			
		25	150	60	982	0.0248	190	Δ	195	3.2	1.82	2.28	600
		60	300	39	989				126	4.9			
		40	300	45	987				146	4.2			
		60	600	30	990				97	6.4			
S11H	280 M6	60	150	55	986				145	4.0			
		40	150	66	983				173	3.3			
		25	150	73	980	0.0273	235	Δ	193	3.0	2.37	2.84	700
		60	300	47	988				124	4.7			
		40	300	55	986				145	4.0			
		60	600	36	991				95	6.1			
S11H	315 S6	60	150	75	990				178	4.1			
		40	150	90	988				214	3.4			
		25	150	100	987	0.0175	260	Δ	238	3.1	3.95	3.95	950
		60	300	65	991				153	4.8			
		40	300	75	990				178	4.1			
		60	600	50	992				118	6.2			
S11H	315 M6	60	150	90	988				179	4.0			
		40	150	108	986				215	3.3			
		25	150	120	984	0.0241	310	Δ	239	3.0	4.31	4.09	1000
		60	300	77	990				154	4.7			
		40	300	90	988				179	4.0			
		60	600	59	992				118	6.1			
S11H	315 MX6	60	150	110	987				197	3.5			
		40	150	132	985				236	2.9			
		25	150	147	983	0.0070	345	Y	263	2.6	6.8	5.8	1290
		60	300	95	989				169	4.1			
		40	300	110	987				197	3.5			
		60	600	73	991				130	5.3			
S11H	315 MY6	60	150	132	989				183	3.6			
		40	150	158	985				220	3.0			
		25	150	176	986	0.0100	445	Y	244	2.7	8.0	6.4	1380
		60	300	114	990				158	4.2			
		40	300	132	989				183	3.6			
		60	600	87	992				121	5.5			
S11H	315 LX6	60	150	160	990				192	3.5			
		40	150	192	989				230	2.9			
		25	150	213	988	0.0101	515	Y	256	2.6	9.6	7.2	1590
		60	300	138	992				165	4.1			
		40	300	160	990				192	3.5			
		60	600	106	993				127	5.3			

Three-phase motors with slip-ring rotor for intermittent periodic duty

Series SPEH and S11H
 with surface cooling, duty type S4 and S5, mean starting torque $M_A = 1.5 * M_N$
 thermal class F, degree of protection IP 54/IP 55

Motor selection data										Design point 400 V, 50 Hz			
Type	S4/S5-	c/h	P	n	R	Rotor	I	M_K/M_B	J_{Motor}	$J_{ext.}$	m		
	%		kW	rpm	Ω	U V	A	-	kgm ²	kgm ²	kg		
Synchronous speed 750 rpm – 8-pole version													
SPEH 132 M8	60	150	2.3	710			9.8	2.9					
	40	150	2.8	700			11.8	2.4					
	25	150	3.1	690	0.3030	145	Y	13.1	2.2	0.048	0.144	85	
	60	300	2.0	715			8.4	3.4					
	40	300	2.3	710			9.8	2.9					
SPEH 132 MX8	60	600	1.5	720			6.5	4.4					
	60	150	3.0	710			11.6	3.0					
	40	150	3.6	700			13.9	2.5					
	25	150	4.0	695	0.2800	160	Y	15.4	2.3	0.058	0.174	95	
	60	300	2.6	712			10.0	3.5					
SPEH 160 M8	40	300	3.0	710			11.6	3.0					
	60	600	2.0	715			7.6	4.5					
	60	150	3.6	725			11.7	3.0					
	40	150	4.3	722			14.0	2.5					
	25	150	4.8	718	0.1980	190	Y	15.6	2.3	0.135	0.405	133	
SPEH 160 L8	60	300	3.1	727			10.1	3.5					
	40	300	3.6	725			11.7	3.0					
	60	600	2.4	733			7.7	4.5					
	60	150	5.5	730			17.0	3.3					
	40	150	6.6	723			20.4	2.8					
SPEH 180 L8	25	150	7.3	720	0.1590	200	Y	22.6	2.5	0.162	0.486	145	
	60	300	4.7	734			14.6	3.8					
	40	300	5.5	730			17.0	3.3					
	60	600	3.6	736			11.2	5.0					
	60	150	7.5	725			22.1	3.7					
SPEH 200 L8	40	150	9.0	718			26.5	3.1					
	25	150	10.0	715	0.1312	210	Y	29.5	2.8	0.279	0.698	204	
	60	300	6.5	727			19.0	4.3					
	40	300	7.5	725			22.1	3.7					
	60	600	5.0	733			14.6	5.6					
SPEH 225 M8	60	150	11.0	728			27.0	3.5					
	40	150	13.2	722			32.5	2.9					
	25	150	14.7	720	0.0977	250	Y	36.0	2.6	0.279	0.698	280	
	60	300	9.5	732			23.4	4.1					
	40	300	11.0	728			27.0	3.5					
SPEH 225 MX8	60	600	7.3	736			17.9	5.3					
	60	150	15.0	728			42.0	3.6					
	40	150	18.0	724			50.5	3.0					
	25	150	20.0	720	0.0526	220	Y	65.0	2.7	0.464	0.928	305	
	60	300	12.9	730			36.0	4.2					
SPEH 250 M8	40	300	15.0	728			42.0	3.6					
	60	600	9.9	735			28.0	5.5					
	60	150	18.5	735			42.5	3.8					
	40	150	22.2	730			51.0	3.2					
	25	150	24.5	730	0.0606	270	Y	56.5	2.9	0.568	1.14	330	
SPEH 250 MX8	60	300	16.0	735			36.5	4.4					
	40	300	18.5	735			42.5	3.8					
	60	600	12.0	738			28.0	5.9					
	60	150	22.0	735			91	3.5					
	40	150	26.0	730			107	3.0					
SPEH 250 M8	25	150	29.0	725	0.0134	150	Y	119	2.7	1.00	2.00	425	
	60	300	19.0	738			78	4.1					
	40	300	22.0	735			91	3.5					
	60	600	14.5	740			60	5.3					

Three-phase motors with slip-ring rotor for intermittent periodic duty

Series SPEH and S11H
 with surface cooling, duty type S4 and S5, mean starting torque $M_A = 1.5 \cdot M_N$
 thermal class F, degree of protection IP 54/IP 55

Motor selection data										Design point 400 V, 50 Hz			
Type	S4/S5-	c/h	P	n	R	Rotor		I	M_K/M_B	J_{Motor}	$J_{ext.}$	m	
	%		kW	rpm	Ω	U		A	-	kgm ²	kgm ²	kg	
Synchronous speed 750 rpm – 8-pole version													
S11H	250 MX8	60	150	27.0	740			88	3.4				
		40	150	32.0	737			104	2.9				
		25	150	36.0	735	0.0409	190	Δ	117	2.6	1.78	3.56	600
		60	300	23.0	741			75	4.0				
		40	300	27.0	740			88	3.4				
		60	600	17.5	743			57	5.2				
S11H	280 S8	60	150	37	738			114	3.5				
		40	150	44	736			136	2.9				
		25	150	49	734	0.0328	200	Δ	151	2.6	1.95	3.90	665
		60	300	32	740			99	4.0				
		40	300	37	738			114	3.5				
		60	600	24	743			74	5.4				
S11H	280 M8	60	150	45	740			111	3.6				
		40	150	54	737			133	3.0				
		25	150	60	734	0.0416	250	Δ	148	2.7	2.37	4.74	710
		60	300	39	742			96	4.2				
		40	300	45	740			111	3.6				
		60	600	30	744			73	5.5				
S11H	315 S8	60	150	60	740			130	3.4				
		40	150	72	739			156	2.8				
		25	150	80	737	0.0317	285	Δ	173	2.6	3.95	7.9	950
		60	300	52	742			112	4.0				
		40	300	60	740			130	3.4				
		60	600	40	744			86	5.2				
S11H	315 M8	60	150	75	740			129	3.1				
		40	150	90	738			154	2.6				
		25	150	100	735	0.0437	360	Δ	172	2.3	4.31	8.6	1000
		60	300	65	742			111	3.6				
		40	300	75	740			129	3.1				
		60	600	50	744			85	4.7				
S11H	315 MX8	60	150	90	742			199	3.4				
		40	150	108	740			238	2.8				
		25	150	120	739	0.0066	280	Y	265	2.6	6.8	11.6	1290
		60	300	77	743			171	4.0				
		40	300	90	742			199	3.4				
		60	600	59	744			131	5.2				
S11H	315 MY8	60	150	110	742			179	3.0				
		40	150	132	741			215	2.5				
		25	150	147	740	0.0090	380	Y	238	2.3	8.1	13.0	1390
		60	300	95	743			154	3.5				
		40	300	110	742			179	3.0				
		60	600	73	744			118	4.5				
S11H	315 LX8	60	150	132	742			185	2.7				
		40	150	158	740			222	2.3				
		25	150	176	739	0.0100	440	Y	247	2.0	9.8	13.7	1600
		60	300	114	743			159	3.1				
		40	300	132	742			185	2.7				
		60	600	87	744			122	4.1				

Three-phase motors with slip-ring rotor for intermittent periodic duty

Series SPEH and S11H
 with surface cooling, duty type S4 and S5, mean starting torque $M_A = 1.5 * M_N$
 thermal class F, degree of protection IP 54/IP 55

Motor selection data		Design point 400 V, 50 Hz												
Type		S4/S5-	c/h	P	n	R	Rotor		I	M_K/M_B	J_{Motor}	$J_{ext.}$	m	
		%		kW	rpm	Ω	U		A	-	kgm ²	kgm ²	kg	
Synchronous speed 600 rpm – 10-pole version														
SPEH	250 M10	60	150	16.5	590				82	3.4				
		40	150	19.8	585				98	2.8				
		25	150	22.0	580	0.0113	125	Y	109	2.6	0.937	1.87	425	
		60	300	14.2	591				70	4.0				
		40	300	16.5	590				82	3.4				
S11H	250 MX10	60	600	10.9	593				54	5.2				
		60	150	20.0	590				82	3.6				
		40	150	24.0	587				99	3.0				
		25	150	26.7	585	0.0366	150	Δ	110	2.7	1.61	3.22	580	
		60	300	17.2	591				71	4.2				
S11H	280 S10	40	300	20.0	590				82	3.6				
		60	600	13.2	593				54	5.5				
		60	150	27.0	589				104	3.2				
		40	150	32.0	587				124	2.7				
		25	150	36.0	585	0.0282	160	Δ	139	2.4	1.82	3.64	600	
S11H	280 M10	60	300	23.0	590				89	3.8				
		40	300	27.0	589				104	3.2				
		60	600	17.5	592				68	4.9				
		60	150	35.0	589				111	2.9				
		40	150	42.0	587				133	2.4				
S11H	315 S10	25	150	46.0	585	0.0331	195	Δ	146	2.2	2.37	4.74	710	
		60	300	30.0	590				95	3.4				
		40	300	35.0	589				111	2.9				
		60	600	23.0	592				73	4.4				
		60	150	44	592				116	3.1				
S11H	315 M10	40	150	53	590				139	2.6				
		25	150	58	588	0.0383	235	Δ	152	2.4	3.95	7.11	950	
		60	300	37	593				97	3.7				
		40	300	44	952				116	3.1				
		60	600	29	594				76	4.7				
S11H	315 MX10	60	150	55	590				119	3.0				
		40	150	66	588				143	2.5				
		25	150	73	586	0.0395	285	Δ	159	2.3	4.31	7.76	1000	
		60	300	47	591				103	3.5				
		40	300	55	590				119	3.0				
S11H	315 MY10	60	600	36	592				79	4.5				
		60	150	70	589				160	2.7				
		40	150	80	588				183	2.3				
		25	150	93	587	0.0099	270	Y	213	2.0	6.8	13.6	1290	
		60	300	58	591				133	3.2				
S11H	315 LX10	40	300	70	589				160	2.7				
		60	600	45	593				103	4.2				
		60	150	80	593				157	2.9				
		40	150	90	592				177	2.6				
		25	150	105	590	0.0258	315	Δ	206	2.2	8.1	16.2	1390	
S11H	315 MY10	60	300	65	594				128	3.6				
		40	300	80	593				157	2.9				
		60	600	50	595				98	4.7				
		60	150	90	592				159	2.6				
		40	150	105	590				185	2.2				
S11H	315 LX10	25	150	115	589	0.0310	350	Δ	203	2.0	9.8	19.6	1600	
		60	300	75	593				132	3.1				
		40	300	90	592				159	2.6				
		60	600	58	594				102	4.0				

Three-phase motors with slip-ring rotor for intermittent periodic duty

Series SPH and S10H, progressive output assignment
with surface cooling, duty type S3,
thermal class F, degree of protection IP 54/IP 55

Motor selection data											Design point 400 V, 50 Hz		
Type	S3- %	P kW	n rpm	I 400 V A	R Ω	Rotor U V	I A	M_K/M_B -	n_{max} rpm	J kgm ²	m kg		
Synchronous speed 1500 rpm – 4-pole version													
SPH 132 M4	100	4.5	1435	10.0			17.5	2.8					
	60	5.4	1420	12.0			21.0	2.4					
	40	6.0	1410	13.0	0.1480	160	Y	23.0	2.1	2500	0.038	85	
	25	6.9	1390	15.0			27.0	1.8					
	15	6.9	1390	15.0			27.0	1.8					
SPH 132 MX4	100	5.7	1450	13.0			18.5	3.7					
	60	6.9	1440	15.0			22.5	3.4					
	40	7.7	1430	16.0	0.1380	190	Y	25.0	2.7	2500	0.043	95	
	25	8.9	1415	19.5			29.0	2.3					
	15	10.0	1400	22.0			33.0	2.0					
SPH 132 L4	100	7.0	1455	16.5			22.0	3.8					
	60	8.5	1445	19.0			27.0	3.1					
	40	9.5	1440	20.5	0.1150	200	Y	30.0	2.8	2500	0.060	105	
	25	11.0	1430	23.5			34.0	2.4					
	15	12.5	1415	27.5			39.0	2.1					
SPH 160 M4	100	10.0	1460	22.5			30.0	4.6					
	60	12.5	1450	25.5			38.0	3.7					
	40	15.0	1440	30.0	0.0583	205	Y	45.0	3.0	2400	0.128	150	
	25	16.5	1430	32.5			50.0	2.7					
	15	18.0	1425	35.0			54.0	2.5					
SPH 160 L4	100	12.5	1470	27.5			34.5	5.2					
	60	15.5	1460	31.5			43.0	4.2					
	40	18.0	1455	35.0	0.0450	225	Y	50.0	3.6	2400	0.145	165	
	25	22.0	1445	42.5			60.0	2.9					
	15	24.0	1440	47.0			66.0	2.7					
SPH 180 M4	100	18.5	1465	34.5			49.5	4.5					
	60	21.0	1460	38.5			57.0	4.0					
	40	24.0	1455	43.5	0.0422	230	Y	65.0	3.5	2200	0.250	225	
	25	28.0	1450	51.0			75.0	3.0					
	15	33.0	1445	63.0			89.0	2.3					
SPH 180 L4	100	22.0	1465	40.5			50.5	4.1					
	60	25.0	1460	45.5			57.5	3.6					
	40	28.0	1455	51.0	0.0438	270	Y	64.0	3.2	2200	0.285	255	
	25	33.0	1450	59.0			75.5	2.7					
	15	40.0	1440	73.0			91.5	2.2					

Three-phase motors with slip-ring rotor for intermittent periodic duty

Series SPH and S10H, progressive output assignment
with surface cooling, duty type S3,
thermal class F, degree of protection IP 54/IP 55

Motor selection data										Design point 400 V, 50 Hz				
Type		S3- %	P kW	n rpm	I 400 V A	R Ω	Rotor U V		I A	M_k/M_B -	n_{max} rpm	J kgm ²	m kg	
Synchronous speed 1500 rpm – 4-pole version														
SPH	200 M4	100	30.0	1475	58.0				56.0	4.9				
		60	34.0	1470	64.0				64.0	4.3				
		40	39.0	1465	72.0	0.3670	330	Y	73.0	3.8	2200	0.476	330	
		25	45.0	1460	82.0				84.0	3.3				
		15	53.0	1455	98.0				99.0	2.8				
SPH	200 L4	100	37.0	1480	70.0				78.0	5.1				
		60	42.0	1475	78.0				88.0	4.5				
		40	48.0	1473	87.0	0.0229	295	Y	101.0	3.9	2200	0.590	375	
		25	55.0	1470	88.5				115.0	3.4				
		15	65.0	1465	117.0				136.0	2.9				
SPH	225 M4	100	45.0	1480	82.5				118.0	4.2				
		60	51.0	1478	91.5				134.0	3.7				
		40	58.0	1475	103.0	0.0105	235	Y	152.0	3.3	2200	0.632	450	
		25	67.0	1470	117.0				176.0	2.8				
		15	80.0	1465	138.0				210.0	2.4				
S10H	250 M4	100	60.0	1480	112.0				154.0	4.4				
		60	68.0	1475	124.0				175.0	3.8				
		40	75.0	1475	135.0	0.00859	240	Y	193.0	3.5	2200	1.030	590	
		25	90.0	1470	159.0				232.0	2.9				
		15	105	1465	188.0				270.0	2.5				
S10H	250 L4	100	75.0	1486	145.0				149.0	5.7				
		60	85.0	1484	160.0				169.0	5.0				
		40	95.0	1483	174.0	0.0239	310	Δ	189.0	4.5	2200	1.850	710	
		25	110	1480	199.0				219.0	3.9				
		15	132	1478	233.0				263.0	3.2				
S10H	280 M4	100	90.0	1488	158.0				179.0	5.8				
		60	100	1487	173.0				199.0	5.3				
		40	115	1485	195.0	0.0181	310	Δ	229.0	4.6	2200	2.850	890	
		25	132	1483	221.0				263.0	4.0				
		15	160	1479	268.0				319.0	3.3				
S10H	280 L4	100	110	1485	185.0				181.0	5.4				
		60	125	1483	208.0				206.0	4.8				
		40	140	1482	230.0	0.0210	375	Δ	231.0	4.3	2200	3.480	1010	
		25	160	1480	264.0				264.0	3.7				
		15	190	1475	310.0				313.0	3.1				

Three-phase motors with slip-ring rotor for intermittent periodic duty

Series SPH and S10H, progressive output assignment
with surface cooling, duty type S3,
thermal class F, degree of protection IP 54/IP 55

Motor selection data										Design point 400 V, 50 Hz		
Type	S3- %	P kW	n rpm	I 400 V A	R Ω	Rotor U V	I A	M_k/M_B -	n_{max} rpm	J kgm ²	m kg	
Synchronous speed 1000 rpm – 6-pole version												
SPH 132 M6	100	3.3	950	8.0			13.0	2.9				
	60	4.0	935	9.6			15.5	2.4				
	40	4.8	915	11.5	0.2210	160	Y	18.5	1.9	2500	0.050	
	25	5.4	900	12.5			21.0	1.7			85	
	15	5.4	900	12.5			21.0	1.7				
SPH 132 MX6	100	4.3	960	10.5			15.0	3.2				
	60	5.2	950	12.0			18.0	2.6				
	40	6.2	935	13.5	0.1920	180	Y	21.0	2.2	2500	0.063	
	25	7.0	925	15.5			24.0	1.9			95	
	15	7.6	915	17.0			26.0	1.8				
SPH 132 L6	100	5.0	960	12.5			15.0	3.5				
	60	6.2	945	14.5			18.0	2.8				
	40	7.3	935	17.0	0.2045	210	Y	21.5	2.4	2500	0.078	
	25	8.3	930	19.0			24.5	2.1			105	
	15	9.0	920	20.0			26.5	1.9				
SPH 160 M6	100	7.7	970	18.5			22.0	3.7				
	60	9.0	965	20.5			26.0	3.1				
	40	10.5	960	23.0	0.1030	215	Y	30.0	2.7	2400	0.162	
	25	12.5	955	26.5			36.0	2.2			145	
	15	13.5	950	28.5			39.0	2.0				
SPH 160 L6	100	11.0	975	27.0			33.0	4.0				
	60	13.0	975	30.0			38.0	3.4				
	40	15.0	970	33.0	0.0582	210	Y	44.0	2.9	2400	0.203	
	25	17.5	965	38.0			52.0	2.5			165	
	15	20.0	960	42.5			59.0	2.2				
SPH 180 M6	100	14.5	975	33.0			39.0	4.0				
	60	16.5	970	36.0			44.0	3.5				
	40	20.0	965	42.0	0.0589	230	Y	54.0	2.9	2200	0.315	
	25	22.0	960	45.5			59.0	2.6			225	
	15	27.0	950	54.5			73.0	2.1				
SPH 180 L6	100	16.0	980	37.0			40.0	4.6				
	60	19.0	975	41.5			47.0	3.9				
	40	23.0	970	47.5	0.0527	250	Y	57.0	3.2	2200	0.358	
	25	26.0	960	52.5			64.0	2.8			255	
	15	32.0	950	63.0			79.0	2.3				
SPH 200 M6	100	22.0	975	44.0			62.0	3.8				
	60	26.0	970	51.0			73.0	3.2				
	40	32.0	965	61.0	0.0350	220	Y	90.0	2.6	2080	0.535	
	25	35.0	960	66.0			99.0	2.4			320	
	15	40.0	955	69.5			113.0	2.1				
SPH 225 M6	100	30.0	980	58.0			77.0	3.7				
	60	36.0	980	69.0			93.0	3.1				
	40	42.0	975	79.5	0.0231	240	Y	108.0	2.6	2080	1.000	
	25	48.0	970	89.5			124.0	2.3			425	
	15	55.0	965	103.0			142.0	2.0				
S10H 250 M6	100	37.0	980	70.5			102.0	3.6				
	60	45.0	980	83.5			124.0	3.0				
	40	52.0	975	96.0	0.0373	225	Δ	143.0	2.6	2080	1.610	
	25	58.0	970	107.0			160.0	2.3			580	
	15	68.0	965	127.0			187.0	2.0				
S10H 250 MX6	100	45.0	985	88.0			116.0	3.9				
	60	54.0	985	104.0			139.0	3.2				
	40	63.0	980	118.0	0.0357	240	Δ	163.0	2.8	2080	1.820	
	25	70.0	975	129.0			180.0	2.5			600	
	15	80.0	975	148.0			206.0	2.2				
S10H 280 M6	100	55.0	988	103.0			131.0	4.0				
	60	67.0	985	122.0			160.0	3.2				
	40	80.0	980	144.0	0.0305	260	Δ	190.0	2.7	2080	3.100	
	25	90.0	980	162.0			212.0	2.4			850	
	15	105	975	190.0			250.0	2.1				
S10H 280 L6	100	75.0	990	143.0			160.0	4.1				
	60	85.0	988	158.0			180.0	3.6				
	40	100	985	181.0	0.0239	290	Δ	212.0	3.1	2080	3.620	
	25	112	985	201.0			238.0	2.8			950	
	15	130	980	233.0			277.0	2.4				

Three-phase motors with slip-ring rotor for intermittent periodic duty

Series SPH and S10H, progressive output assignment
with surface cooling, duty type S3,
thermal class F, degree of protection IP 54/IP 55

Motor selection data										Design point 400 V, 50 Hz		
Type	S3- %	P kW	n rpm	I 400 V A	R Ω	Rotor U V	I A	M _K /M _B -	n _{max} rpm	J kgm ²	m kg	
Synchronous speed 750 rpm – 8-pole version												
SPH 132 M8	100	2.3	710	7.7			10.0	2.9				
	60	2.8	700	8.5			12.5	2.3				
	40	3.3	685	9.4	0.3030	145	Y	15.0	2.0	2500	0.048	85
	25	3.3	685	9.4			15.0	2.0				
	15	3.3	685	9.4			15.0	2.0				
SPH 132 MX8	100	3.0	710	9.4			11.5	3.0				
	60	3.6	700	10.5			14.0	2.5				
	40	4.3	690	12.0	0.2800	160	Y	16.5	2.0	2500	0.058	95
	25	4.9	680	13.0			19.0	1.8				
	15	4.9	680	13.0			19.0	1.8				
SPH 132 L8	100	3.6	715	11.0			12.0	3.2				
	60	4.5	705	12.5			15.0	2.5				
	40	5.3	695	13.5	0.2780	190	Y	17.5	2.1	2500	0.068	105
	25	6.0	680	15.5			19.5	1.8				
	15	6.2	675	16.0			20.0	1.8				
SPH 160 M8	100	5.3	730	16.5			16.5	3.5				
	60	6.0	725	17.0			19.0	3.0				
	40	7.2	720	19.0	0.1590	205	Y	22.0	2.5	2400	0.163	145
	25	8.0	715	20.5			25.0	2.2				
	15	8.5	715	21.5			26.0	2.1				
SPH 160 L8	100	7.0	730	22.0			19.5	3.6				
	60	8.5	730	24.0			24.0	2.9				
	40	9.5	725	26.0	0.1300	225	Y	26.0	2.6	2400	0.190	170
	25	11.5	720	31.0			32.0	2.1				
	15	12.5	715	34.0			35.0	1.9				
SPH 180 M8	100	11.0	725	29.0			31.0	3.3				
	60	13.0	720	31.5			37.0	2.7				
	40	15.5	715	36.0	0.0823	220	Y	44.0	2.3	2200	0.308	225
	25	17.5	710	39.5			49.0	2.0				
	15	20.0	705	45.0			56.0	1.8				
SPH 180 L8	100	14.0	730	35.5			38.0	3.8				
	60	17.0	725	39.5			46.0	3.1				
	40	20.0	720	40.5	0.0611	230	Y	54.0	2.6	2200	0.365	260
	25	22.5	715	50.5			61.0	2.3				
	15	26.0	710	57.5			70.0	2.0				
SPH 200 M8	100	18.5	730	45.0			60.0	3.4				
	60	21.0	730	48.5			68.0	3.0				
	40	25.0	725	55.0	0.0257	190	Y	81.0	2.5	1875	0.568	330
	25	28.0	720	60.5			91.0	2.2				
	15	33.0	715	71.0			108.0	1.9				
SPH 225 M8	100	22.0	735	50.5			68.0	3.4				
	60	25.0	730	54.5			77.0	3.0				
	40	32.0	725	66.5	0.0218	200	Y	99.0	2.3	1875	0.990	425
	25	36.0	725	74.0			111.0	2.1				
	15	42.0	720	85.0			130.0	1.8				
S10H 250 M8	100	30.0	735	62.0			90.0	2.9				
	60	35.0	730	71.0			105.0	2.5				
	40	42.0	725	84.0	0.0488	210	Δ	126.0	2.1	1875	1.780	600
	25	48.0	725	97.0			145.0	1.8				
	15	48.0	725	97.0			145.0	1.8				
S10H 250 L8	100	37.0	738	86.5			103.0	3.5				
	60	43.0	736	96.0			118.0	3.0				
	40	52.0	734	112.0	0.0380	225	Δ	143.0	2.5	1875	1.950	665
	25	60.0	732	126.0			165.0	2.2				
	15	68.0	730	140.0			186.0	1.9				
S10H 280 M8	100	45.0	740	101.0			110.0	3.9				
	60	52.0	740	113.0			128.0	3.4				
	40	63.0	737	133.0	0.0348	250	Δ	158.0	2.8	1875	3.100	850
	25	68.0	735	142.0			170.0	2.6				
	15	77.0	735	162.0			190.0	2.3				
S10H 280 L8	100	55.0	740	121.0			126.0	3.5				
	60	67.0	740	143.0			153.0	2.9				
	40	80.0	737	166.0	0.0340	270	Δ	183.0	2.4	1875	3.620	950
	25	90.0	735	184.0			206.0	2.1				
	15	105	730	216.0			240.0	1.8				

Three-phase motors with slip-ring rotor for intermittent periodic duty

Series SPH and S10H, progressive output assignment
with surface cooling, duty type S3,
thermal class F, degree of protection IP 54/IP 55

Motor selection data											Design point 400 V, 50 Hz		
Type		S3- %	P kW	n rpm	I 400 V A	R Ω	Rotor U V		I A	M_K/M_B -	n_{max} rpm	J kgm ²	m kg
Synchronous speed 600 rpm – 10-pole version													
SPH	225 M10	100	16.0	590	48.0				50.0	3.2			
		60	21.0	585	56.0				65.0	2.4			
		40	24.0	580	61.0	0.0324	200	Y	74.0	2.1	1500	0.937	425
		25	28.0	580	68.0				87.0	1.8			
		15	28.0	580	68.0				87.0	1.8			
S10H	250 M10	100	20.0	590	65.0				57.0	3.4			
		60	26.0	585	72.5				75.0	2.6			
		40	30.0	585	79.0	0.0831	220	Δ	86.0	2.3	1500	1.520	580
		25	34.0	580	86.5				98.0	2.0			
		15	34.0	580	86.5				98.0	2.0			
S10H	250 MX10	100	24.0	590	86.5				68.0	3.7			
		60	30.0	585	93.0				85.0	3.0			
		40	36.0	585	103.0	0.0584	220	Δ	101.0	2.5	1500	1.730	600
		25	43.0	580	114.0				121.0	2.1			
		15	43.0	580	114.0				121.0	2.1			
S10H	280 M10	100	33.0	590	90.0				89.0	3.0			
		60	40.0	590	100.0				108.0	2.5			
		40	45.0	585	109.0	0.0462	230	Δ	121.0	2.2	1500	3.100	850
		25	52.0	585	125.0				140.0	1.9			
		15	52.0	585	125.0				140.0	1.9			
S10H	280 L10	100	43.0	590	103.0				102.0	2.5			
		60	50.0	585	116.0				119.0	2.2			
		40	55.0	585	127.0	0.0523	260	Δ	131.0	2.0	1500	3.620	950
		25	60.0	585	137.0				143.0	1.8			
		15	60.0	585	137.0				143.0	1.8			

Bearings

Slip-ring contact system components

Series SPER, S11R

Bearings

Type SPER S11R	Number of poles	Anti-friction bearing	D-end			N-end		Type of lubrication	Figure	
			V-ring	Wave spring	Disc spring	Anti-friction bearing	V-ring		D-end	N-end
132	M4-8	6308 2Z C3	-	90	-	6308 2Z C3	-	Permanent lubrication	2/1	2/13
132	MX4-8	6308 2Z C3	-	90	-	6308 2Z C3	-		2/1	2/13
160	M4-8	6310 2Z C3	-	110	-	6309 2Z C3	-		2/1	2/13
160	L4-8	6310 2Z C3	-	110	-	6309 2Z C3	-		2/1	2/13
180	L4-8	6310 C3	50 A	110	-	6310 C3	50 A		2/3	2/4
200	L4-8	6312 C3	60 A	-	130	6312 C3	60 A		2/3	2/4
200	M4-8	6312 C3	60 A	-	130	6312 C3	60 A		2/3	2/4
225	M4-8	6313 C3	65 A	-	140	6312 C3	60 A		2/3	2/4
225	MX6, 8	6313 C3	65 A	-	140	6312 C3	60 A		2/3	2/4
250	M, MX4	6315 C3	75 A	-	160	6313 C3	65 A		2/3	2/4
250	MX6, 8	NU 316 EJ	80 A	-	-	6314 C3	70 A		2/5	2/4
280	S, M4	NU 316 EJ	80 A	-	-	6314 C3	70 A		2/5	2/4
280	M6, 8	NU 316 EJ	80 A	-	-	6314 C3	70 A		2/5	2/4
315	S4-8	NU 317 EJ	85 A	-	-	6316 C3	80 A	2/5	2/4	
315	M4-8	NU 317 EJ	85 A	-	-	6316 C3	80 A	2/5	2/4	
315	MX, MY4-8	NU 320 EJ	100 ¹⁾	-	-	6317 C3 ²⁾	85 A	Relubrication facility	2/22	2/23
315	LX4-8, LY4	NU 320 EJ	100 ¹⁾	-	-	6317 C3 ²⁾	85 A	2/22	2/23	

1) Gamma ring RB 100

2) For vertical construction type Q 317

Slip-ring contact system components

Type SPER/ S11R	Number of poles	Box-type brush holder Order no.	Carbon brushes Order no.	Slip-ring body Order no.
132	M4, 6, 8	TIKZ2f 10 x 8-16-42-21	10 x 8 x 25/RC53 25938 01	E 100 x 55-310 12294 01
132	MX4, 6, 8	13867 01	10 x 8 x 25/RC53 25938 01	E 100 x 55-310 12294 01
160	M4, L4	TIKZ2f 10 x 8-16-42-21	10 x 8 x 25/C40 01500 01	E 120 x 65-310 12280 01
160	M6, 8	13867 01	10 x 8 x 25/RC53 01503 01	E 120 x 65-310 12280 01
160	L6, 8		10 x 8 x 25/RC53 01503 01	E 120 x 65-310 12280 01
180	L4	TIKZ2f 16 x 8-16-45-21	16 x 8 x 25/RC90 24743 01	E 140 x 80-316 12293 01
180	L6, 8	12271 01	16 x 8 x 25/RC53 01501 01	E 140 x 80-316 12293 01
200	L4, 6, 8	TIKZ2f 16 x 12.5-20-52-23.5	16 x 12.5 x 32/RC53 01502 01	E 160 x 90-316 12302 01
200	LX4	14487 01	16 x 12.5 x 32/RC53 01502 01	E 160 x 90-316 12302 01
225	M4	TIKZ2f 16 x 12.5-20-52-23.5	16 x 12.5 x 32/RC90 24745 01	E 160 x 90-316 12302 01
225	M6, 8	14487 01	16 x 12.5 x 32/RC53 01502 01	E 160 x 90-316 12302 01
225	MX6, 8		16 x 12.5 x 32/RC53 01502 01	E 160 x 90-316 12302 01
250	M4, 6, 8	TIKZ2f 25 x 12.5-20-56.5-23.5	25 x 12.5 x 32/C40 50281 01	E 160 x 95-316 12286 01
250	MX4	12275 01	25 x 12.5 x 32/C40 50281 01	E 160 x 95-316 12286 01
250	MX6, 8		25 x 12.5 x 32/C40 50283 01	E 180 x 105-316 16527 01
280	S4, 6	TIKZ2f 25 x 12.5-20-56.5-23.5	25 x 12.5 x 32/B14Z1 63010 01	E 180 x 105-316 16527 01
280	M4, 6	12275 01	25 x 12.5 x 32/B14Z1 63010 01	E 180 x 105-316 16527 01
280	S, M8		25 x 12.5 x 32/C40 50283 01	E 180 x 105-316 16527 01
315	S4, 6	TIKZ2f 32 x 12.5-20-60-23.5	32 x 12.5 x 32/ B14Z1 61869 01	E 200 x 120-316 16529 01
315	M4, 6	12276 01	32 x 12.5 x 32/ B14Z1 61869 01	E 200 x 120-316 16529 01
315	S, M8		32 x 12.5 x 32/C40 50285 01	E 200 x 120-316 16529 01
315	MX, MY4-8	DKS 3216	32 x 16 x 40/C40 57393 01	SK 111 EW-N 9012 57793 01
315	LX4-8, LY4	57402 01	32 x 16 x 40/C40 57393 01	SK 111 EW-N 9012 57793 01

Series SPEH, S11H

Bearings

Type SPEH/ S11H	Number of poles	Anti-friction bearing	D-end			N-end		Type of lubrication	Figure	
			V-ring	Wave spring	Disc spring	Anti-friction bearing	V-ring		D-end	N-end
132	M4-8	6308 2Z C3	-	90	-	6308 2Z C3	-	Permanent lubrication	2/1	2/13
132	MX4-8	6308 2Z C3	-	90	-	6308 2Z C3	-		2/1	2/13
160	M4-8	6310 2Z C3	-	110	-	6309 2Z C3	-		2/1	2/13
160	L4-8	6310 2Z C3	-	110	-	6309 2Z C3	-		2/1	2/13
180	L4-8	6310 C3	50 A	110	-	6310 C3	50 A		2/3	2/4
200	L4-8	6312 C3	60 A	-	130	6312 C3	60 A		2/3	2/4
200	LX4	6312 C3	60 A	-	130	6312 C3	60 A		2/3	2/4
225	M4-8	6313 C3	65 A	-	140	6312 C3	60 A		2/3	2/4
225	MX6, 8	6313 C3	65 A	-	140	6312 C3	60 A		2/3	2/4
250	M, MX4	6315 C3	75 A	-	160	6313 C3	65 A		2/3	2/4
250	MX6, 8	NU 316 EJ	80 A	-	-	6314 C3	70 A		2/5	2/4
280	S, M4	NU 317 EJ	85 A	-	-	6314 C3	70 A		2/5	2/4
280	M6, 8	NU 317 EJ	85 A	-	-	6314 C3	70 A		2/5	2/4
315	S4-8	NU 319 EJ	95 A	-	-	6316 C3	80 A		2/5	2/4
315	M4-8	NU 319 EJ	95 A	-	-	6316 C3	80 A	2/5	2/4	
315	MX, MY4-8	NU 320 EJ	100 ¹⁾	-	-	6317 C3 ²⁾	85 A	Relubrication facility	1/22	1/23
315	LX4-8, LY4	NU 320 EJ	100 ¹⁾	-	-	6317 C3 ²⁾	85 A	Relubrication facility	1/22	1/23

¹⁾ Gamma ring RB 100

²⁾ For vertical construction type Q 317

Slip-ring contact system components

Type SPEH/ S11H	Number of poles	Box-type brush holder Order no.	Carbon brushes Order no.	Slip-ring body Order no.
132	M4, 6, 8	TIKZ2f 10 x 8-16-42-21	10 x 8 x 25/RC53 25938 01	E 100 x 55-310 12294 01
132	MX4, 6, 8	13867 01	10 x 8 x 25/RC53 25938 01	E 100 x 55-310 12294 01
160	M4, L4	TIKZ2f 10 x 8-16-42-21	10 x 8 x 25/C40 01500 01	E 120 x 65-310 12280 01
160	M6, 8	13867 01	10 x 8 x 25/RC53 01503 01	E 120 x 65-310 12280 01
160	L6, 8		10 x 8 x 25/RC53 01503 01	E 120 x 65-310 12280 01
180	L4	TIKZ2f 16 x 8-16-45-21	16 x 8 x 25/RC90 24743 01	E 140 x 80-316 12293 01
180	L6, 8	12271 01	16 x 8 x 25/C40 57461 01	E 140 x 80-316 X6 20492 01
200	L4, 6, 8	TIKZ2f 16 x 12.5-20-52-23.5	16 x 12.5 x 32/RC53 01502 01	E 160 x 90-316 12302 01
200	LX4	14487 01	16 x 12.5 x 32/RC53 01502 01	E 160 x 90-316 12302 01
225	M4	TIKZ2f 16 x 12.5-20-52-23.5	16 x 12.5 x 32/RC90 24745 01	E 160 x 90-316 12302 01
225	M6, 8	14487 01	16 x 12.5 x 32/RC53 01502 01	E 160 x 90-316 12302 01
225	MX6, 8		16 x 12.5 x 32/RC53 01502 01	E 160 x 90-316 12302 01
250	M4, 6, 8	TIKZ2f 25 x 12.5-20-56.5-23.5	25 x 12.5 x 32/C40 50281 01	E 160 x 95-316 12286 01
250	MX4	12275 01	25 x 12.5 x 32/C40 50281 01	E 160 x 95-316 12286 01
250	MX6, 8		25 x 12.5 x 32/C40 50283 01	E 180 x 105-316 16527 01
280	S4, 6	TIKZ2f 32 x 12.5-20-60-23.5	32 x 12.5 x 32/C40 57441 01	E 180 x 105-316 16527 01
280	M4, 6	12276 01	32 x 12.5 x 32/C40 57441 01	E 180 x 105-316 16527 01
280	S, M8	TIKZ2f 25 x 12.5-20-56.5-23.5 12275 01	25 x 12.5 x 32/C40 50283 01	E 180 x 105-316 16527 01
315	S4, 6	TIKZ2f 32 x 12.5-20-60-23.5	32 x 12.5 x 32/B14Z1 61869 01	E 200 x 120-316 16529 01
315	M4, 6	12276 01	32 x 12.5 x 32/B14Z1 61869 01	E 200 x 120-316 16529 01
315	S, M8		32 x 12.5 x 32/C40 50285 01	E 200 x 120-316 16529 01
315	MX, MY4-8	DKS 3216	32 x 16 x 40/C40 57393 01	SK 111 EW-N 9012 57793 01
315	LX4-8, LY4	57402 01	32 x 16 x 40/C40 57393 01	SK 111 EW-N 9012 57793 01

Series SPR, SPH

Bearings

Type SPR SPH	Anti-friction bearing	D-end			N-end		Figure		Type of lubrication
		V-ring	Wave spring	Disc spring	Anti-friction bearing	V-ring	D-end	N-end	
132	6308 2Z C3	-	90	-	6308 2Z C3	-	2/1	2/13	Permanent lubrication
160	6310 2Z C3	-	110	-	6309 2Z C3	-	2/1	2/13	
180	6312 C3	60 A	-	130	6310 C3	50 A	2/3	2/4	
200	6313 C3	65 A	-	140	6312 C3	60 A	2/3	2/4	
225	6314 C3	70 A	-	150	6313 C3	65 A	2/3	2/4	
250	NU 316 EJ	80 A	-	-	6314 C3	70 A	2/5	2/4	
280	NU 317 EJ	85 A	-	-	6316 C3	80 A	2/5	2/4	

Slip-ring contact system components

Type SPR	Number of poles	Box-type brush holder Order no.	Carbon brushes Order no.	Slip-ring body Order no.
132	all	TIKZ2f 10 x 8-16-42-21 13867 01	10 x 8 x 25/RC53 25938 01	E 100 x 55-310 12294 01
160	all	TIKZ2f 10 x 8-16-42-21 13867 01	10 x 8 x 25/C40 01500 01	E 120 x 65-310 12280 01
180	all	TIKZ2f 16 x 8-16-45-21 12271 01	16 x 8 x 25/RC90 24743 01	E 140 x 80-316 12293 01
200	all	TIKZ2f 16 x 12.5-20-52-23.5 14487 01	16 x 12.5 x 32/RC90 24745 01	E 160 x 90-316 12302 01
225	all	TIKZ2f 16 x 12.5-20-52-23.5 14487 01	16 x 12.5 x 32/RC90 24745 01	E 160 x 95-316 12286 01
250	all	TIKZ2f 20 x 12.5-20-54-23.5 12273 01	20 x 12.5 x 32/RC90 24747 01	E 180 x 105-316 16527 01
280	all	TIKZ2f 25 x 12.5-20-56.5-23.5 12275 01	25 x 12.5 x 32/RC90 24749 01	E 200 x 120-316 16529 01
Type SPH				
132	all	TIKZ2f 10 x 8-16-42-21 13867 01	10 x 8 x 25/RC53 25938 01	E 100 x 55-310 12294 01
160	all	TIKZ2f 10 x 8-16-42-21 13867 01	10 x 8 x 25/C40 01500 01	E 120 x 65-310 12280 01
180	M, L4	TIKZ2f 16 x 8-16-45-21 12271 01	16 x 8 x 25/RC90 24743 01	E 140 x 80-316 12293 01
180	M, L6, 8		16 x 8 x 25/C40 57461 01	E 140 x 80-316 X6 20492 01
200	all	TIKZ2f 16 x 12.5-20-52-23.5 14487 01	16 x 12.5 x 32/RC90 24745 01	E 160 x 90-316 12302 01
225	all	TIKZ2f 16 x 12.5-20-52-23.5 14487 01	16 x 12.5 x 32/RC90 24745 01	E 160 x 95-316 12286 01
250	all	TIKZ2f 20 x 12.5-20-54-23.5 12273 01	20 x 12.5 x 32/RC90 24747 01	E 180 x 105-316 16527 01
280	all	TIKZ2f 25 x 12.5-20-56.5-23.5 12275 01	25 x 12.5 x 32/RC90 24749 01	E 200 x 120-316 16529 01

Figures

Figure 2/1	Figure 2/2	Figure 2/3	Figure 2/4
Figure 2/5	Figure 2/6	Figure 2/7	Figure 2/8
Figure 2/9	Figure 2/10	Figure 2/11	Figure 2/12
Figure 2/13	Figure 2/14	Figure 2/15	Figure 2/16

Figures

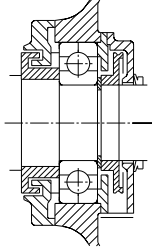
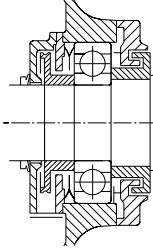
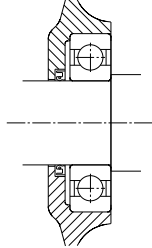
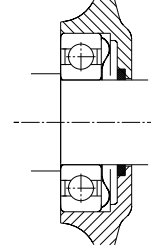
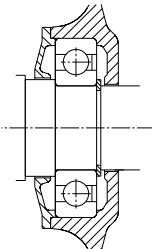
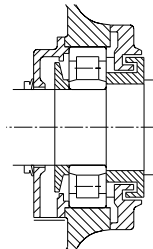
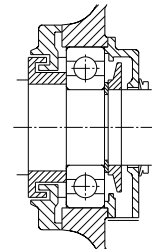
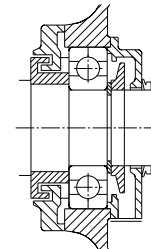
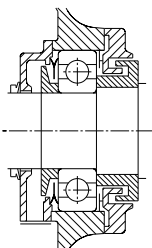
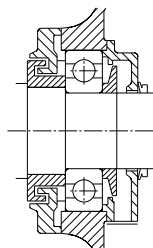
			
Figure 2/17	Figure 2/18	Figure 2/19	Figure 2/20
			
Figure 2/21	Figure 2/22	Figure 2/23	Figure 2/24
			
Figure 2/25	Figure 2/26		

Terminal boxes

Standard version, sealed cable glands

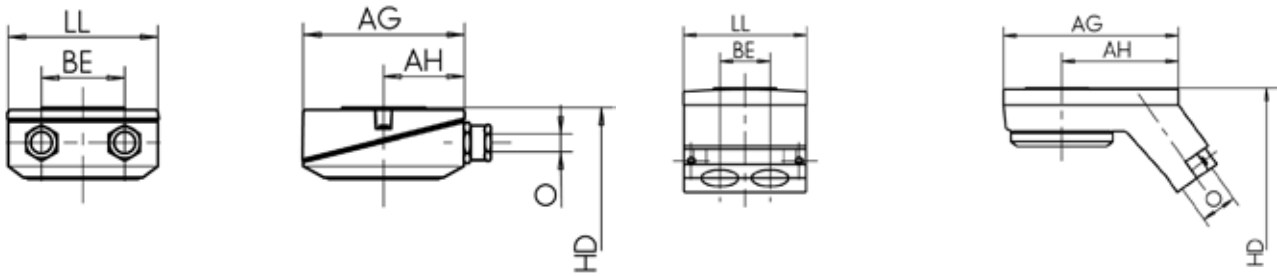

Standard terminal box for screwed cable glands

Standard terminal box for sealed cable glands

Type	Material	Adapter flange	Dimensions				Cable gland thread	Max. cable diameter	Terminal mounting	Number of terminals	Thread of terminal stud	Thread of protective conductor	Figure
			AG	LL	AH	BE							
Standard version													
25 A	Alu	-	156	145	-	-	M32 x 1.5	Ø 21 mm	SB 5	6	M5	M6	01
25 A SS	GG-15	-	143	134	-	-	M32 x 1.5	Ø 21 mm	SB 5	6	M5	M6	01
63/25 A	Alu	-	193	167	-	-	M40 x 1.5	Ø 28 mm	SB 5	6	M5	M6	01
63 A	Alu	-	193	167	-	-	M40 x 1.5	Ø 28 mm	SB 6	6	M6	M6	01
63 A	GG-15	-	174	162	-	-	M40 x 1.5	Ø 28 mm	SB 6	6	M6	M6	01
63 A	Alu	-	193	167	-	-	M50 x 1.5	Ø 35 mm	SB 6	6	M6	M6	01
63 A	GG-15	-	174	162	-	-	M50 x 1.5	Ø 35 mm	SB 6	6	M6	M6	01
100 A	GG-15	-	213	207	-	-	M50 x 1.5	Ø 35 mm	SB 8	6	M8	M8	01
200/100 A	GG-15	-	282	242	-	-	M63 x 1.5	Ø 45 mm	SB 8	6	M8	M8	01
200 A	GG-15	-	282	242	-	-	M63 x 1.5	Ø 45 mm	SB 10	6	M10	M10	01
400 A	GG-15	-	315	294	-	-	M63 x 1.5	Ø 45 mm	SB 12	6	M12	M10	02
400 B	GG-15	-	415	340	265	-	M63 x 1.5	Ø 45 mm	KM 12	6	M12	LK	03
400 B	GG-15	-	415	340	265	-	M72 x 2	Ø 56.5 mm	KM 12	6	M12	LK	03
Sealed cable glands													
VGK 200 A	GG-15	-	387	242	-	-	Ø 66	Ø 66 mm	SB 10	6	M10	M10	04
VGK 400 A	GG-15	-	422	296	-	-	Ø 95	Ø 95 mm	SB 12	6	M12	M10	04

Standard version, sealed cable glands

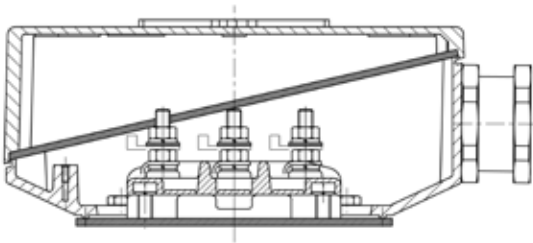

Figure 01

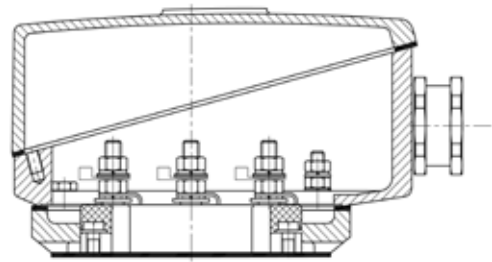

Figure 02

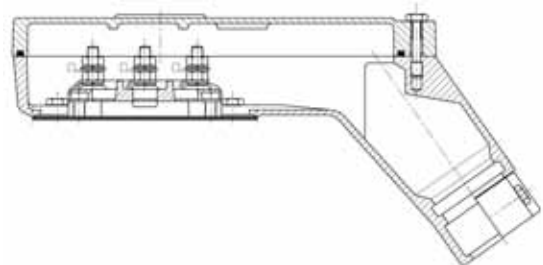
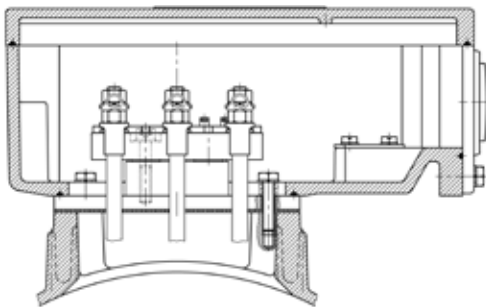
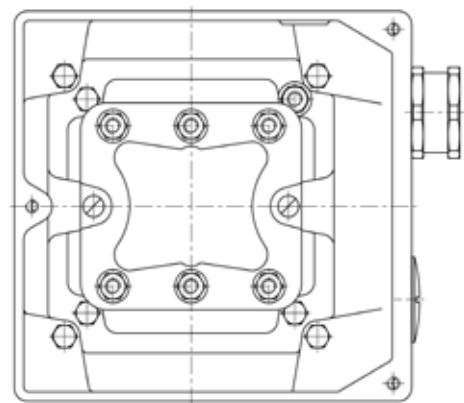
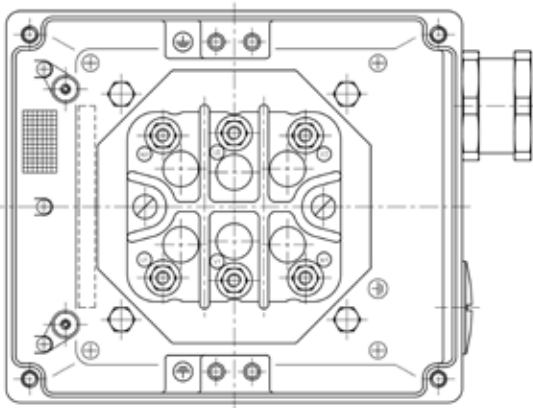

Figure 04

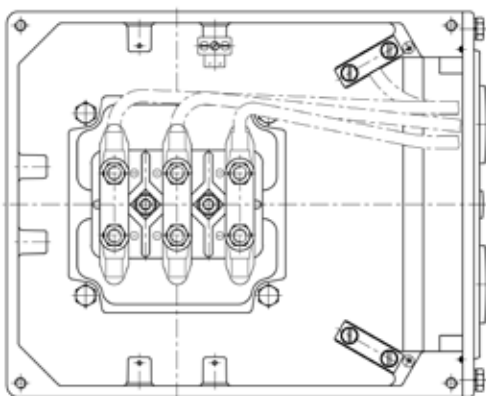

Figure 03

Dimensions

Three-phase motors with slip-ring rotor Basic version SPER 132–250/S11R 250–315 M

with surface cooling, type of cooling IC 411, degree of protection IP 54/IP 55

Type of construction IM B3 [IM 1001], IM 1002

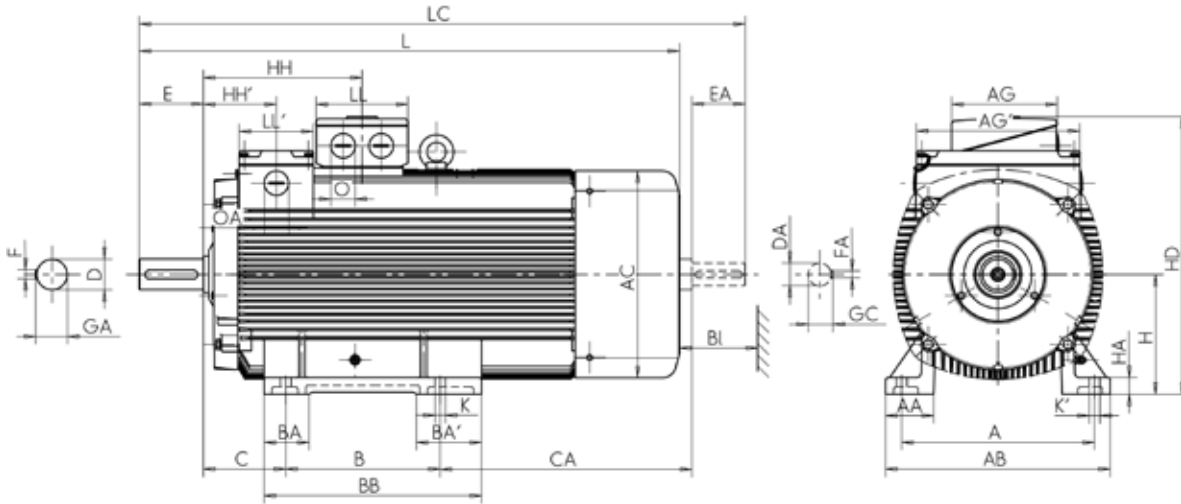

Type of construction IM B35 [IM 2001], IM 2002

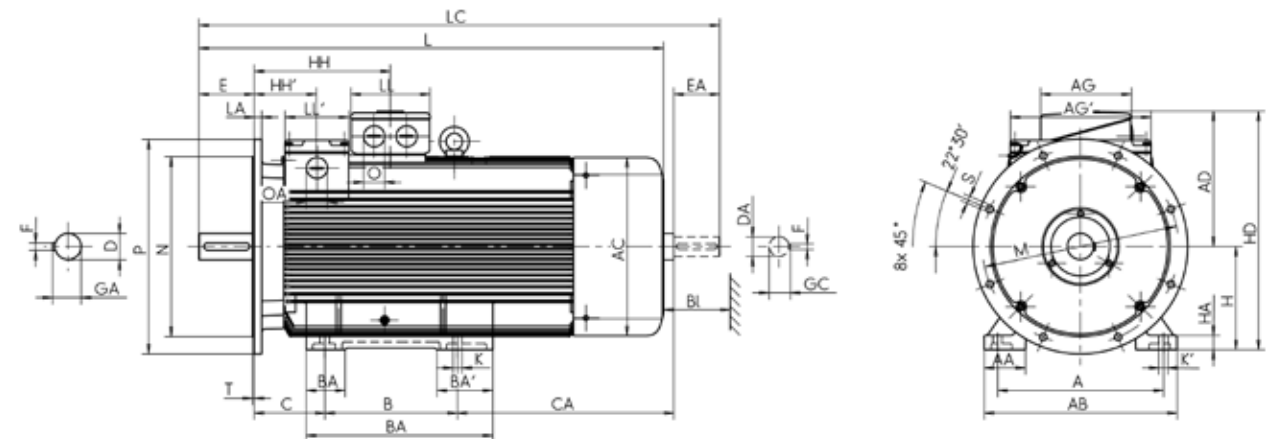

Type																			
IM B5	IM B35	A	AA	AB	AC	B	BA	BA'	BB	C	CA	D	DA	E	EA	F	FA		
b	n	f	g	a	m	m1	e	w1	w2	d	d1	Centre hole DIN 332-DS	l	l1	u	u1			
SPER 132 M	A300	A300	216	50	256	258	178	55	55	218	89	300	38	38	M12	80	80	10	10
SPER 132 MX	A300	A300	216	50	256	258	178	55	55	218	89	300	38	38	M12	80	80	10	10
SPER 160 M	A350	A350	254	55	296	313	210	60	60	257	108	339	42	42	M16	110	110	12	12
SPER 160 L	A350	A350	254	55	296	313	254	60	60	301	108	305	42	42	M16	110	110	12	12
SPER 180 L	A350	A350	279	62	328	351	279	65	65	326	121	315	48	48	M16	110	110	14	14
SPER 200 L	A400	A400	318	70	372	390	305	70	70	360	133	393	55	55	M20	110	110	16	16
SPER 200 LX	A400	A400	318	70	372	390	305	70	70	360	133	393	55	55	M20	110	110	16	16
SPER 225 M	A450	A450	356	75	413	390	311	75	75	368	149	371	60	55	M20	140	110	18	16
SPER 225 MX	A450	A450	356	75	413	390	311	75	75	368	149	371	60	55	M20	140	110	18	16
SPER 250 M	A550	A550	406	84	471	440	349	84	84	412	168	426	65	60	M20	140	140	18	18
S11R 250 MX6	A550	A550	406	84	469	490	349	84	84	412	168	524	65	60	M20	140	140	18	18
S11R 280 S4	A550	A550	457	94	522	490	368	96	96	431	190	483	75	60	M20	140	140	20	18
S11R 280 S8	A550	A550	457	94	522	490	368	96	138	482	190	563	75	60	M20	140	140	20	18
S11R 280 M4	A550	A550	457	94	522	490	419	96	138	482	190	512	75	60	M20	140	140	20	18
S11R 280 M6	A550	A550	457	94	522	490	419	96	138	482	190	512	75	60	M20	140	140	20	18
S11R 315 S4	A660	A660	508	126	590	550	406	120	120	520	216	583	80	65	M20	170	140	22	18
S11R 315 S6	A660	A660	508	126	590	550	406	120	172	572	216	663	80	65	M20	170	140	22	18
S11R 315 M	A660	A660	508	126	590	550	457	120	172	572	216	612	80	65	M20	170	140	22	18

Three-phase motors with slip-ring rotor Basic version SPER 132–250/S11R 250–315 M

with surface cooling, type of cooling IC 411, degree of protection IP 54/IP 55

Type of construction IM B5 [IM 3001], IM 3002; IM V1 [IM 3011], IM 2012

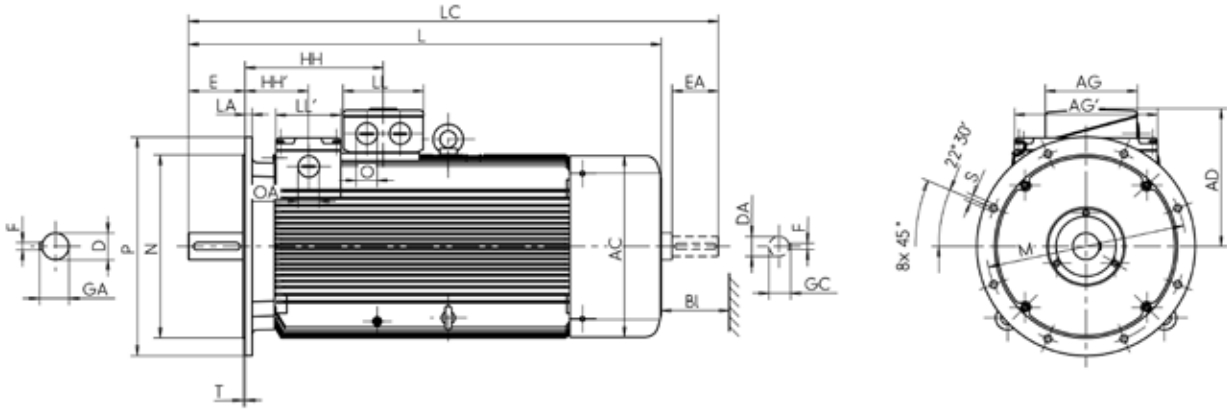

Type	GA	GC	H	HA	HD	K	K'	L	LC	LD	LD	LE	Terminal box			Slip-ring compartment			Hole pattern			
	t	t1	h	c	p (B3)	s	s'	k	k1	A (IM B3)	A (IM B5)	A1	Type	x'	z'	r	AG'	LL'	OA	BI	Hole pattern	NDE possible
SPER 132 M	41	41	132	16	331	12	12	643	727	242	242	-	25 A	156	145	M32 x 1.5	221	120	M32 x 1.5	35	4	no
SPER 132 MX	41	41	132	16	331	12	12	643	727	242	242	-	25 A	156	145	M32 x 1.5	221	120	M32 x 1.5	35	4	no
SPER 160 M	45	45	160	18	402	15	15	762	877	292	292	-	63 A	193	167	M40 x 1.5	272	140	M40 x 1.5	35	4	no
SPER 160 L	45	45	160	18	402	15	15	762	877	292	292	-	63 A	193	167	M40 x 1.5	272	140	M40 x 1.5	35	4	no
SPER 180 L	52	52	180	20	441	15	15	819	935	301	301	-	63 A	193	167	M40 x 1.5	292	140	M40 x 1.5	35	4	no
SPER 200 L	59	59	200	22	500	19	19	927	1051	331	331	-	100 A	213	207	M50 x 1.5	310	145	M50 x 1.5	40	4	no
SPER 200 LX	59	59	200	22	500	19	19	927	1051	331	331	-	100 A	213	207	M50 x 1.5	310	145	M50 x 1.5	40	4	no
SPER 225 M	64	59	225	25	525	19	19	957	1081	331	331	-	100 A	213	207	M50 x 1.5	310	145	M50 x 1.5	40	8	yes
SPER 225 MX	64	59	225	25	525	19	19	957	1081	331	331	-	100 A	213	207	M50 x 1.5	310	145	M50 x 1.5	40	8	yes
SPER 250 M	69	64	250	28	576	24	24	1072	1224	342	342	-	100 A	213	207	M50 x 1.5	382	195	M50 x 1.5	45	8	yes
S11R 250 MX6	69	64	250	28	636	24	24	1166	1321	411	411	-	200 A	282	242	M63 x 1.5	382	195	M63 x 1.5	50	8	yes
S11R 280 S4	80	64	280	40	696	24	30	1166	1321	411	411	-	200 A	282	242	M63 x 1.5	382	195	M63 x 1.5	50	8	yes
S11R 280 S8	80	64	280	40	696	24	30	1246	1401	411	411	-	200 A	282	242	M63 x 1.5	382	195	M63 x 1.5	50	8	yes
S11R 280 M4	80	64	280	40	696	24	30	1246	1401	411	411	-	200 A	282	242	M63 x 1.5	382	195	M63 x 1.5	50	8	yes
S11R 280 M6	80	64	280	40	696	24	30	1246	1401	411	411	-	200 A	282	242	M63 x 1.5	382	195	M63 x 1.5	50	8	yes
S11R 315 S4	85	69	315	44	731	28	35	1348	1515	416	416	-	200 A	282	242	M63 x 1.5	430	195	M63 x 1.5	55	8	yes
S11R 315 S6	85	69	315	44	731	28	35	1428	1595	416	416	-	200 A	282	242	M63 x 1.5	430	195	M63 x 1.5	55	8	yes
S11R 315 M	85	69	315	44	731	28	35	1428	1595	416	416	-	200 A	282	242	M63 x 1.5	430	195	M63 x 1.5	55	8	yes

Three-phase motors with slip-ring rotor
Basic version S11R 315 MX, MY, LX, LY

with surface cooling, type of cooling IC 411, degree of protection IP 55

Type of construction IM B3 [IM 1001], IM 1002

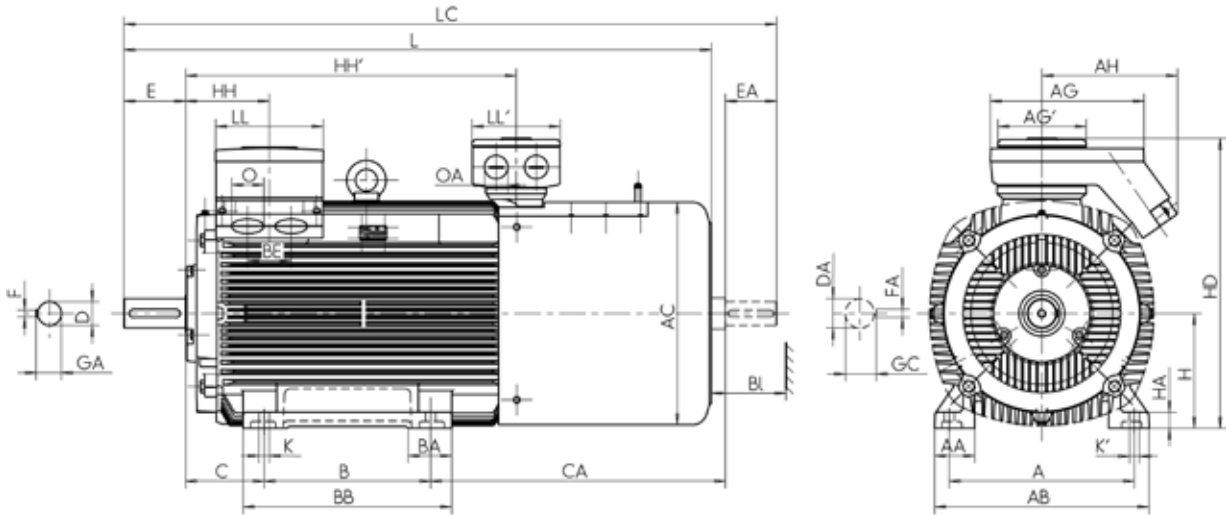

Type of construction IM B35 [IM 2001], IM 2002

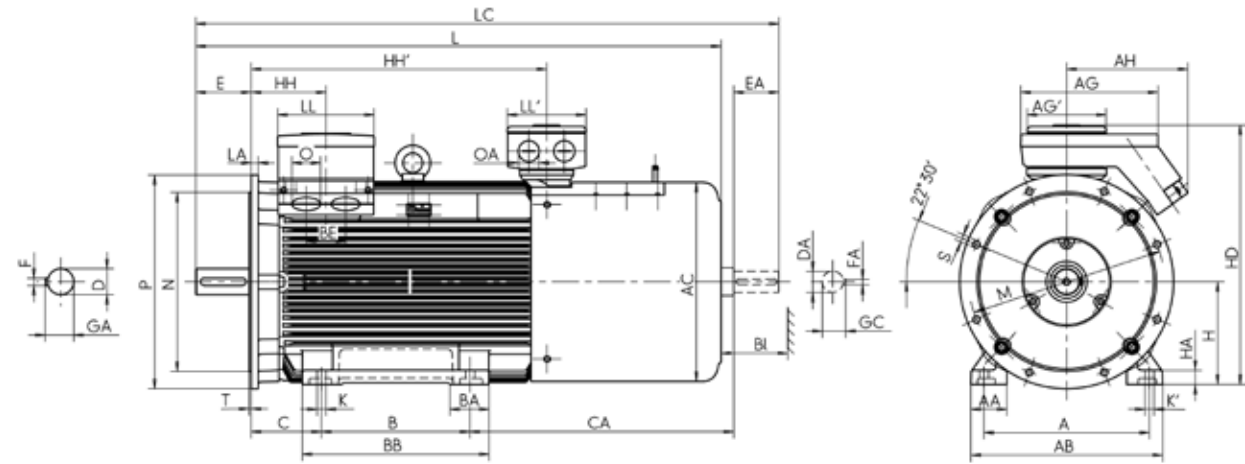

Type	IM B5	IM B35	A	AA	AB	AC	B	BA	BA'	BB	C	CA	D	DA	Centre hole DIN 332-DS	E	EA	F	FA
	b	n	f	g	a	m	m1	e	w1	w2	d	d1		l	l1	u	u1		
S11R 315 MX4	A660	A660	508	110	590	610	457	120	120	573	216	810	80	65	M20	170	140	22	18
S11R 315 MY4	A660	A660	508	110	590	610	457	120	120	573	216	810	80	65	M20	170	140	22	18
S11R 315 LX4	A660	A660	508	110	590	610	508	120	120	624	216	879	80	65	M20	170	140	22	18
S11R 315 LY4	A660	A660	508	110	590	610	508	120	120	624	216	879	80	65	M20	170	140	22	18

Three-phase motors with slip-ring rotor Basic version S11R 315 MX, MY, LX, LY

with surface cooling, type of cooling IC 411, degree of protection IP 55

Type of construction IM V1 [IM 3011], IM 3012

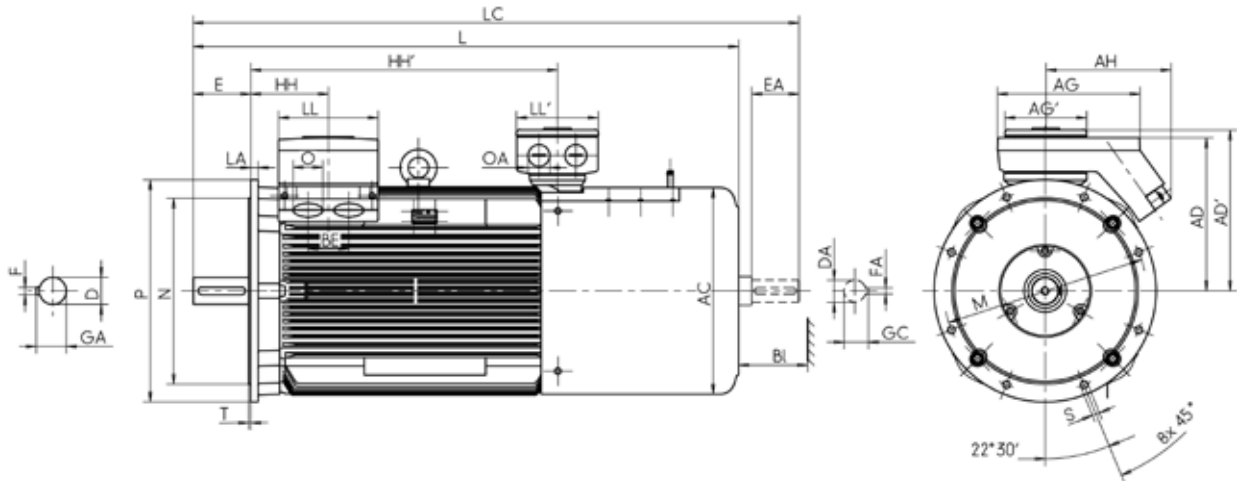

Type	GA	GC	H	HA	HD	K	K'	L	LC	LD	LD	LE	AG	LL	O	AG'	LL'	OA	-	-	-		
	t	t1	h	c	p (B3)	s	s'	k	k1	A (IM B3)	A (IM B5)	A1	Type	x'	z'	r	Type	x'	z'	r	BI	Hole pattern	NDE possible
	S11R 315 MX4	85	69	315	44	800	28	35	1613	1793	230	230	675	VGK400 A	422	296	0 95	200 A	282	242	M63 x 1.5	55	8
S11R 315 MY4	85	69	315	44	800	28	35	1613	1793	230	230	675	VGK400 A	422	296	0 95	200 A	282	242	M63 x 1.5	55	8	yes
S11R 315 LX4	85	69	315	44	800	28	35	1733	1913	230	230	795	VGK400 A	422	296	0 95	200 A	282	242	M63 x 1.5	55	8	yes
S11R 315 LY4	85	69	315	44	800	28	35	1733	1913	230	230	795	VGK400 A	422	296	0 95	200 A	282	242	M63 x 1.5	55	8	yes

**Three-phase motors with slip-ring rotor
Basic version SPER 132-160**

with surface cooling, type of cooling IC 411, degree of protection IP 54/IP 55

Type of construction IM B34 [IM 2101], IM 2102

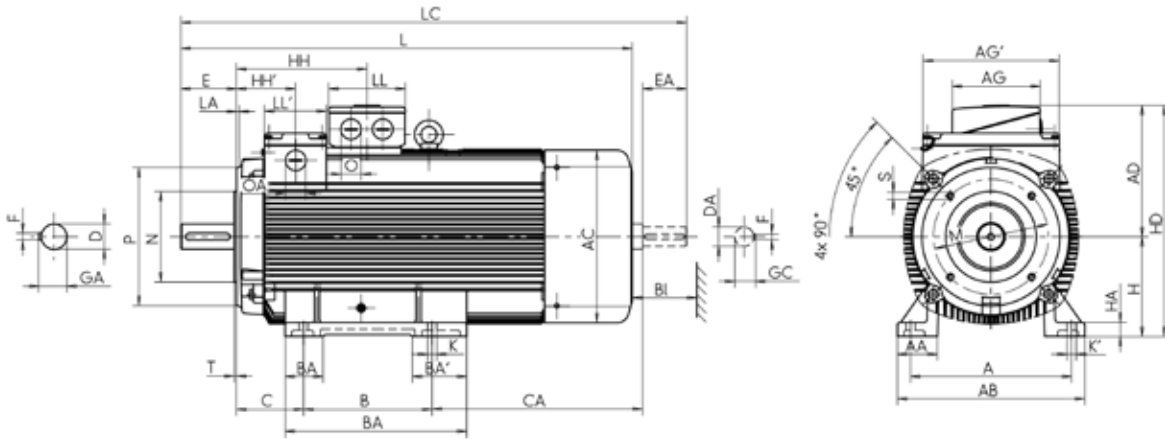

Type	IM B14K, IM B34 K	IM B14G, IM B34 G	A	AA	AB	AC	B	BA	BA'	BB	C	CA	D	DA	Centre hole	l	l1	u	u1
SPER 132 M	C200	C250	216	50	256	258	178	55	55	218	89	300	38	38	DIN 332-DS M12	80	80	10	10
SPER 132 MX	C200	C250	216	50	256	258	178	55	55	218	89	300	38	38	DIN 332-DS M12	80	80	10	10
SPER 160 M	C250	C300	254	55	296	313	210	60	60	257	108	339	42	42	DIN 332-DS M16	110	110	12	12
SPER 160 L	C250	C300	254	55	296	313	254	60	60	301	108	305	42	42	DIN 332-DS M16	110	110	12	12

Three-phase motors with slip-ring rotor Basic version SPER 132-160

with surface cooling, type of cooling IC 411, degree of protection IP 54/IP 55

Type of construction IM B14 [IM 2101], IM 2102

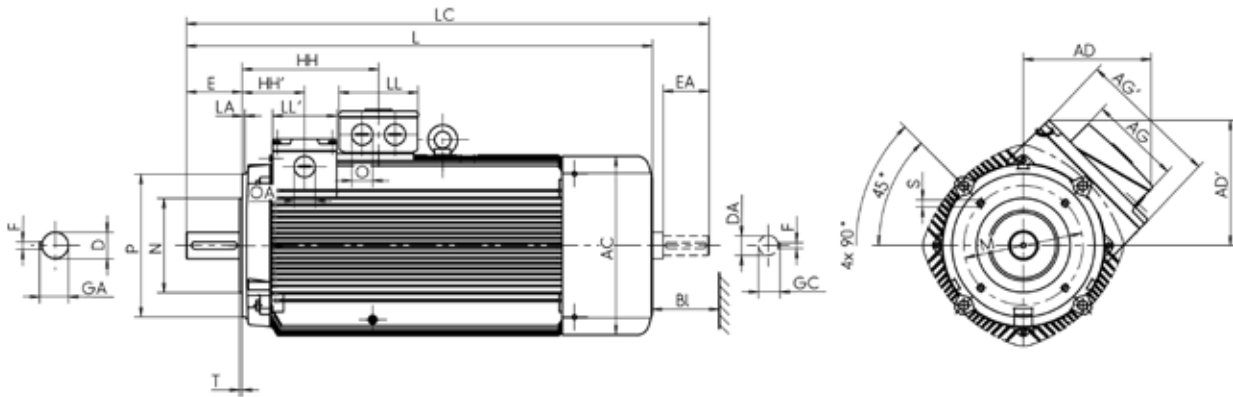

	GA	GC	H	HA	HD	K	K'	L	LC	LD	LD	LE	AG	LL	O	AG'	LL'	OA	-	-	-	
	t	t1	h	c	p (B3)	s	s'	k	k1	A (IM B14K)	A (IM B14G)	A1	Type	x	z	r	x'	z'	r'	BI	Hole pattern	NDE possible
SPER 132 M	41	41	132	16	331	12	12	643	727	242	242	-	25 A	156	145	M32 x 1.5	221	120	M32 x 1.5	35	4	no
SPER 132 MX	41	41	132	16	331	12	12	643	727	242	242	-	25 A	156	145	M32 x 1.5	221	120	M32 x 1.5	35	4	no
SPER 160 M	45	45	160	18	402	15	15	762	877	292	292	-	63 A	193	167	M40 x 1.5	272	140	M40 x 1.5	35	4	no
SPER 160 L	45	45	160	18	402	15	15	762	877	292	292	-	63 A	193	167	M40 x 1.5	272	140	M40 x 1.5	35	4	no

**Three-phase motors with slip-ring rotor
Basic version SPR/S10R 132–280**

with surface cooling, type of cooling IC 411, degree of protection IP 54/IP 55

Type of construction IM B3 [IM 1001], IM 1002

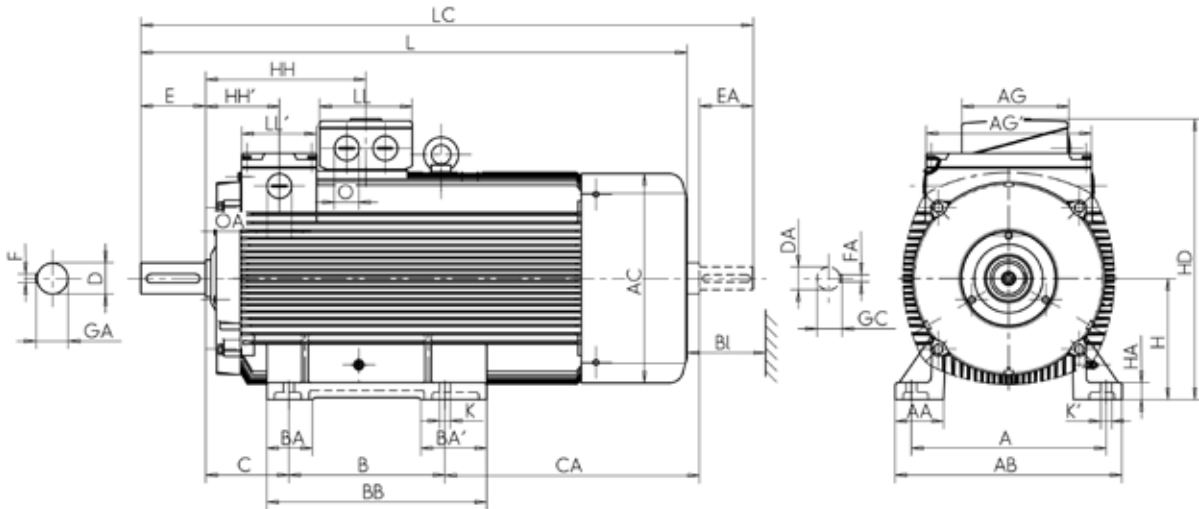

Type of construction IM B3 [IM 1001], IM 1002

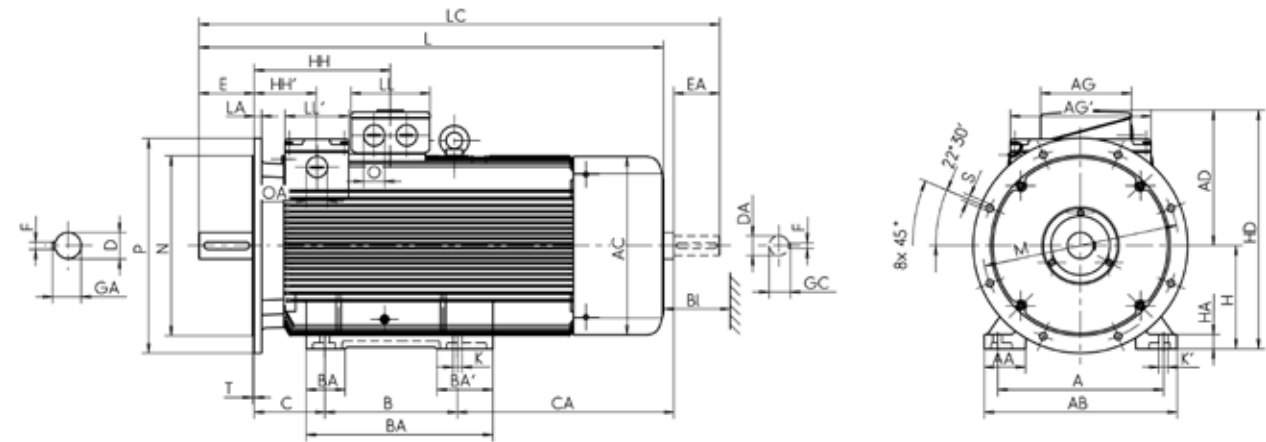

-	-	A	AA	AB	AC	B	BA	BA'	BB	C	CA	D	DA	-	E	EA	F	FA
---	---	---	----	----	----	---	----	-----	----	---	----	---	----	---	---	----	---	----

Type	B5	B35	b	n	f	g	a	e	m	m1	w1	w2	d	d1	Centre hole DIN 332-DS	l	l1	u	u1
SPR 132 M	A350	A350	216	50	256	258	178	218	55	55	89	300	38	38	M12	80	80	10	10
SPR 132 L	A350	A350	216	50	256	258	203	243	55	55	89	313	38	38	M12	80	80	10	10
SPR 160 M	A350	A400	254	55	296	313	210	257	60	60	108	339	48	42	M16	110	110	14	12
SPR 160 L	A350	A400	254	55	296	313	254	301	60	60	108	325	48	42	M16	110	110	14	12
SPR 180 M	A400	A450	279	62	328	351	241	288	65	65	121	353	55	48	M20	110	110	16	14
SPR 180 L	A400	A450	279	62	328	351	279	326	65	65	121	371	55	48	M20	110	110	16	14
SPR 200 M	A450	A450	318	70	372	390	267	322	70	70	133	431	60	55	M20	140	110	18	16
SPR 200 L	A450	A450	318	70	372	390	305	360	70	70	133	453	60	55	M20	140	110	18	16
SPR 225 M	A550	A550	356	75	413	440	311	368	75	75	149	481	65	55	M20	140	110	18	16
S10R 250M	A550	A550	406	80	470	490	349	412	-	-	168	523	75	65	M20	140	140	20	18
S10R 250L	A550	A550	406	80	470	490	406	469	-	-	168	546	75	65	M20	140	140	20	18
S10R 280M	A660	A660	457	88	522	550	419	482	-	-	190	596	80	70	M20	170	140	22	20
S10R 280L	A660	A660	457	88	522	550	457	520	-	-	190	638	80	70	M20	170	140	22	20

Three-phase motors with slip-ring rotor Basic version SPR/S10R 132–280

with surface cooling, type of cooling IC 411, degree of protection IP 54/IP 55

Type of construction IM B5 [IM 3001], IM 3002; IM V1 [IM 3011], IM 3012

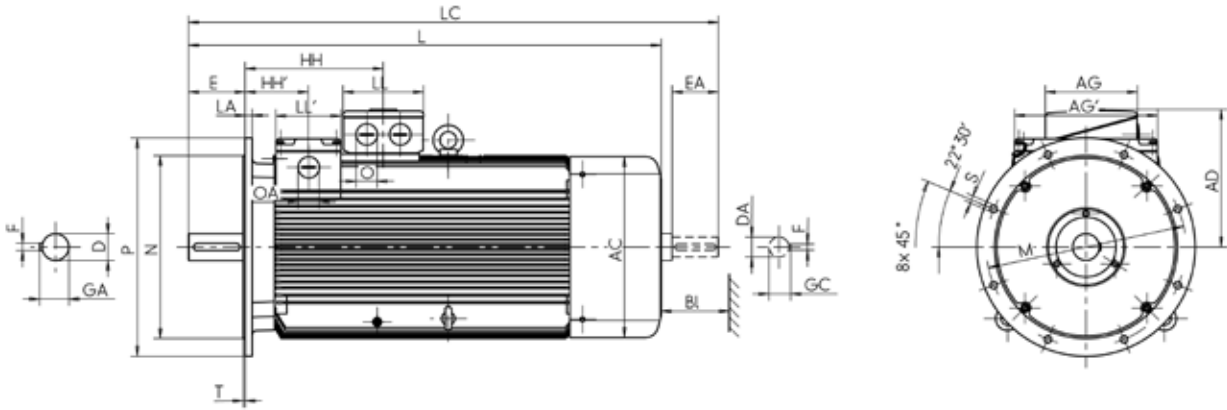

Type	GA	GC	H	HA	HD	HD	K	K'	L	LC	LD	LD	AG	LL	0	AG'	LL'	OA	-	-	-	
	t	t1	h	c	p (B3)	p (B3 VIK KK)	s	s'	k	k1	A (IM B3)	A (IM B5)	Terminal box			Slip-ring compartment			BI	Hole pattern	NDE possible	
													Type	x	z	r	x'	z'	r			
SPR 132 M	41	41	132	16	331	331	12	12	643	727	242	242	25 A	156	145	M32 x 1.5	221	120	M32 x 1.5	35	4L	no
SPR 132 L	41	41	132	16	331	331	12	12	681	765	242	242	25 A	156	145	M32 x 1.5	221	120	M32 x 1.5	35	4L	no
SPR 160 M	51.5	45	160	18	402	402	15	15	762	877	292	292	63 A	193	167	M40 x 1.5	272	140	M40 x 1.5	35	4L	no
SPR 160 L	51.5	45	160	18	402	402	15	15	792	907	292	292	63 A	193	167	M40 x 1.5	272	140	M40 x 1.5	35	4L	no
SPR 180 M	59	51.5	180	20	441	441	15	15	819	935	301	301	63 A	193	167	M40 x 1.5	292	140	M40 x 1.5	35	8L	no
SPR 180 L	59	51.5	180	20	441	441	15	15	875	991	301	301	100 A	213	207	M50 x 1.5	292	140	M50 x 1.5	35	8L	no
SPR 200 M	64	59	200	22	500	500	19	19	957	1081	331	331	100 A	213	207	M50 x 1.5	310	145	M50 x 1.5	40	8L	no
SPR 200 L	64	59	200	22	500	500	19	19	1017	1141	331	331	100 A	213	207	M50 x 1.5	310	145	M50 x 1.5	40	8L	yes
SPR 225 M	69	59	225	25	549	549	19	19	1069	1191	339	339	100 A	213	207	M50 x 1.5	310	145	M50 x 1.5	45	8L	yes
S10R 250 M	79.5	69	250	40	636	645	24	24	1166	1321	411	411	200 A	282	242	M63 x 1.5	382	195	M63 x 1.5	50	8L	yes
S10R 250 L	79.5	69	250	40	636	645	24	24	1246	1401	411	411	200 A	282	242	M63 x 1.5	382	195	M63 x 1.5	50	8L	yes
S10R 280 M	85	74.5	280	40	696	705	24	30	1363	1515	416	416	200 A	282	242	M63 x 1.5	382	195	M63 x 1.5	55	8L	yes
S10R 280 L	85	74.5	280	40	696	705	24	30	1443	1595	416	416	200 A	282	242	M63 x 1.5	382	195	M63 x 1.5	55	8L	yes

Three-phase motors with slip-ring rotor Basic version SPR 132–160

with surface cooling, type of cooling IC 411, degree of protection IP 54/IP 55

Type of construction IM B34 [IM 2101], IM 2102

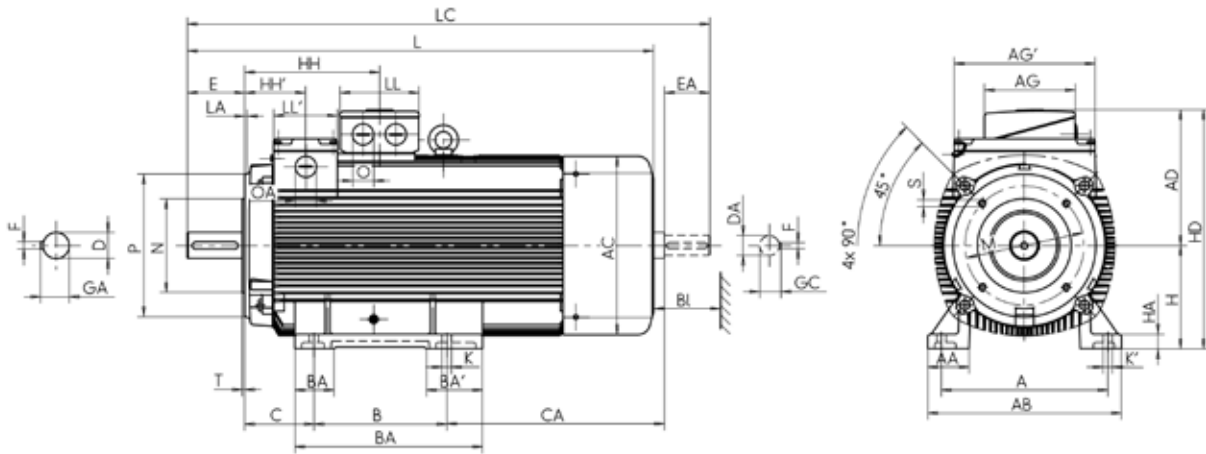

Type	B14 K, B34 K	B14 G, B34 G	A	AA	AB	AC	B	BB	BA	BA'	C	CA	D	DA	Centre hole DIN 332-DS	E	EA	F	FA
	b	n	f	g	a	e	m	m1	w1	w2	d	d1		l	l1	u	u1		
SPR132 M	C200	C250	216	50	256	258	178	218	55	55	89	300	38	38	M12	80	80	10	10
SPR132 L	C200	C250	216	50	256	258	203	243	55	55	89	313	38	38	M12	80	80	10	10
SPR160 M	C250	C300	254	55	296	313	210	257	60	60	108	339	48	42	M16	110	110	14	12
SPR160 L	C250	C300	254	55	296	313	254	301	60	60	108	325	48	42	M16	110	110	14	12

Three-phase motors with slip-ring rotor Basic version SPR 132–160

with surface cooling, type of cooling IC 411, degree of protection IP 54/IP 55

Type of construction IM B14 [IM 3601], IM 3602

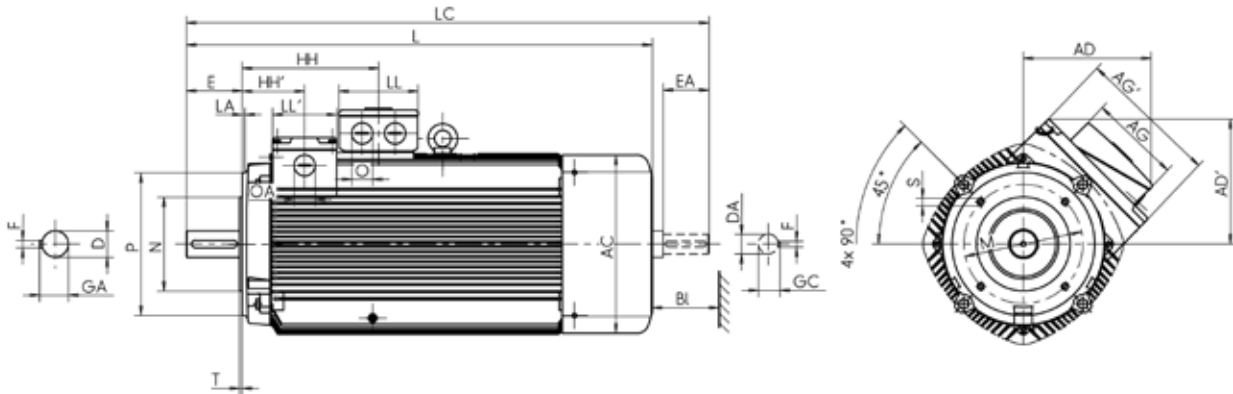

Type	GA	GC	H	HA	HD	HD	K	K'	L	LC	LD	LD	LD	LD	AG'	LL'	0	AG'	LL'	OA	-	-	
	t	t1	h	c	p (B3)	p (B3 VIK KK)	s	s'	k	k1	A (IM B3)	A (IM B5)	A (IM B14K)	A (IM B14G)	Terminal box			Slip-ring compartment			Bl	Hole pattern	
															Type	x'	z'	r	x'	z'	r		
SPR 132 M	41	41	132	16	331	331	12	12	643	727	242	242	242	242	25 A	156	145	M32 x 1.5	221	120	M32 x 1.5	35	4L
SPR 132 L	41	41	132	16	331	331	12	12	681	765	242	242	242	242	25 A	156	145	M32 x 1.5	221	120	M32 x 1.5	35	4L
SPR 160 M	51.5	45	160	18	402	402	15	15	762	877	292	292	292	292	63 A	193	167	M40 x 1.5	272	140	M40 x 1.5	35	4L
SPR 160 L	51.5	45	160	18	402	402	15	15	792	907	292	292	292	292	63 A	193	167	M40 x 1.5	272	140	M40 x 1.5	35	4L

Three-phase motors with slip-ring rotor
Basic version SPEH 132–250/S11H 250–315 M

with surface cooling, type of cooling IC 411, degree of protection IP 54/IP 55

Type of construction IM B3 [IM 1001], IM 1002
 Cylindrical shaft end

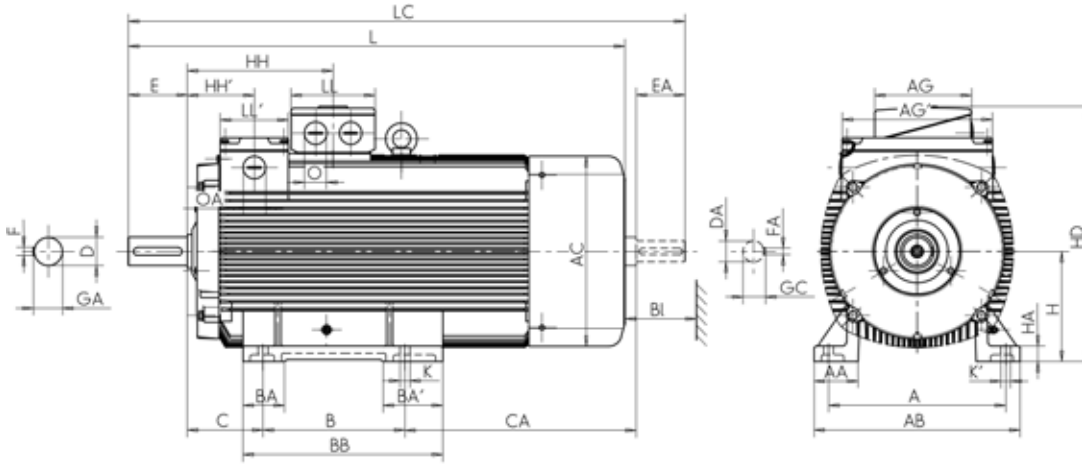

Type of construction IM B3K [IM 1003], IM 1004
 Tapered shaft end to DIN 1448, taper 1:10, with shoulder nut

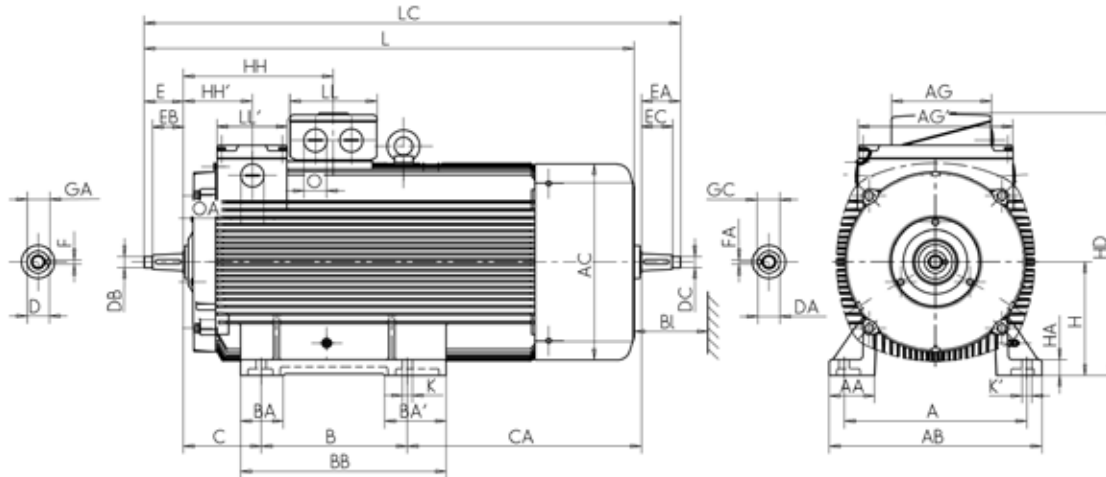

	-		A	AA	AB	AC	B	BA	BA'	BB	C	CA	D	DA	-	DB	DC	DIN	E	EA	F	FA	EB	EC	F	FA
	B5	B35	b	n	f	g	a	m	m1	e	w1	w2	d	d1	Centre hole DIN 332-DS	d2	d3	l	l1	u	u1	l2	l2	u	u1	u2
SPEH 132 M	A300	A300	216	50	256	258	178	55	55	218	89	300	38	38	M12	M24 x 2	M24 x 2	1448	80	80	10	10	58	58	6	6
SPEH 132 MX	A300	A300	216	50	256	258	178	55	55	218	89	300	38	38	M12	M24 x 2	M24 x 2	1448	80	80	10	10	58	58	6	6
SPEH 160 M	A350	A350	254	55	296	313	210	60	60	257	108	339	42	42	M16	M24 x 2	M24 x 2	1448	110	110	12	12	82	82	10	10
SPEH 160 L	A350	A350	254	55	296	313	254	60	60	301	108	305	42	42	M16	M24 x 2	M24 x 2	1448	110	110	12	12	82	82	10	10
SPEH 180 L	A350	A350	279	62	328	351	279	65	65	326	121	315	48	48	M16	M30 x 2	M30 x 2	1448	110	110	14	14	82	82	12	12
SPEH 200 L	A400	A400	318	70	372	390	305	70	70	360	133	393	55	55	M20	M36 x 3	M36 x 3	1448	110	110	16	16	82	82	14	14
SPEH 200 LX	A400	A400	318	70	372	390	305	70	70	360	133	393	55	55	M20	M36 x 3	M36 x 3	1448	110	110	16	16	82	82	14	14
SPEH 225 M	A450	A450	356	75	413	390	311	75	75	368	149	371	60	55	M20	M42 x 3	M36 x 3	1448	140	110	18	16	105	82	16	14
SPEH 225 MX	A450	A450	356	75	413	390	311	75	75	368	149	371	60	55	M20	M42 x 3	M36 x 3	1448	140	110	18	16	105	82	16	14
SPEH 250 M	A550	A550	406	84	471	440	349	84	84	412	168	426	70	60	M20	M48 x 3	M42 x 3	1448	140	140	20	18	105	105	18	16
S11H 250 MX6	A550	A550	406	84	469	490	349	84	84	412	168	524	70	60	M20	M48 x 3	M42 x 3	1448	140	140	20	18	105	105	18	16
S11H 280 S4	A550	A550	457	94	522	490	368	96	96	431	190	483	80	65	M20	M56 x 4	M42 x 3	1448	170	140	22	18	130	105	20	16
S11H 280 S8	A550	A550	457	94	522	490	368	96	138	482	190	563	80	65	M20	M56 x 4	M42 x 3	1448	170	140	22	18	130	105	20	16
S11H 280 M4	A550	A550	457	94	522	490	419	96	138	482	190	512	80	65	M20	M56 x 4	M42 x 3	1448	170	140	22	18	130	105	20	16
S11H 280 M6	A550	A550	457	94	522	490	419	96	138	482	190	512	80	65	M20	M56 x 4	M42 x 3	1448	170	140	22	18	130	105	20	16
S11H 315 S4	A660	A660	508	126	590	550	406	120	120	520	216	583	90	70	M24	M64 x 4	M48 x 3	1448	170	140	25	20	130	105	22	18
S11H 315 S6	A660	A660	508	126	590	550	406	120	172	572	216	663	90	70	M24	M64 x 4	M48 x 3	1448	170	140	25	20	130	105	22	18
S11H 315 M	A660	A660	508	126	590	550	457	120	172	572	216	612	90	70	M24	M64 x 4	M48 x 3	1448	170	140	25	20	130	105	22	18

Three-phase motors with slip-ring rotor Basic version SPEH 132–250/S11H 250–315 M

with surface cooling, type of cooling IC 411, degree of protection IP 54/IP 55

Type of construction IM B35 [IM 2001], IM 2002
Cylindrical shaft end

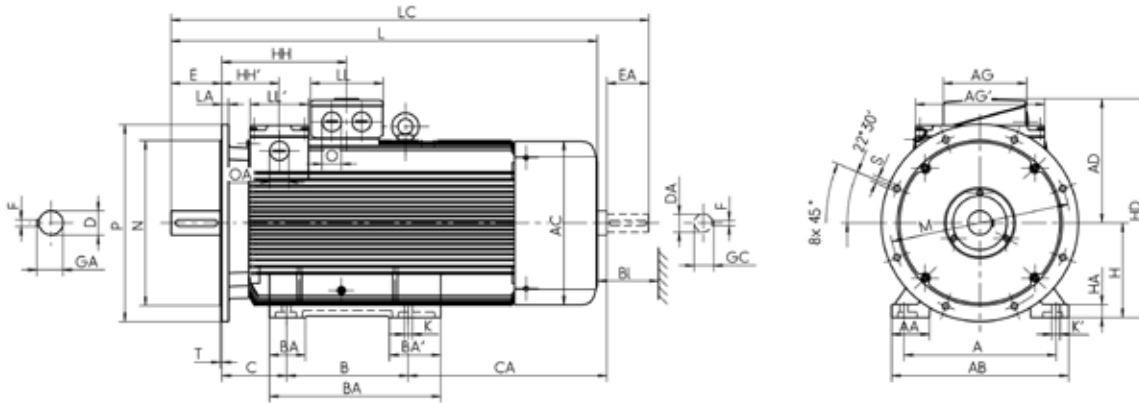

Type of construction IM B35K [IM 2003], IM 2004
Tapered shaft end to DIN 1448, taper 1:10, with shoulder nut

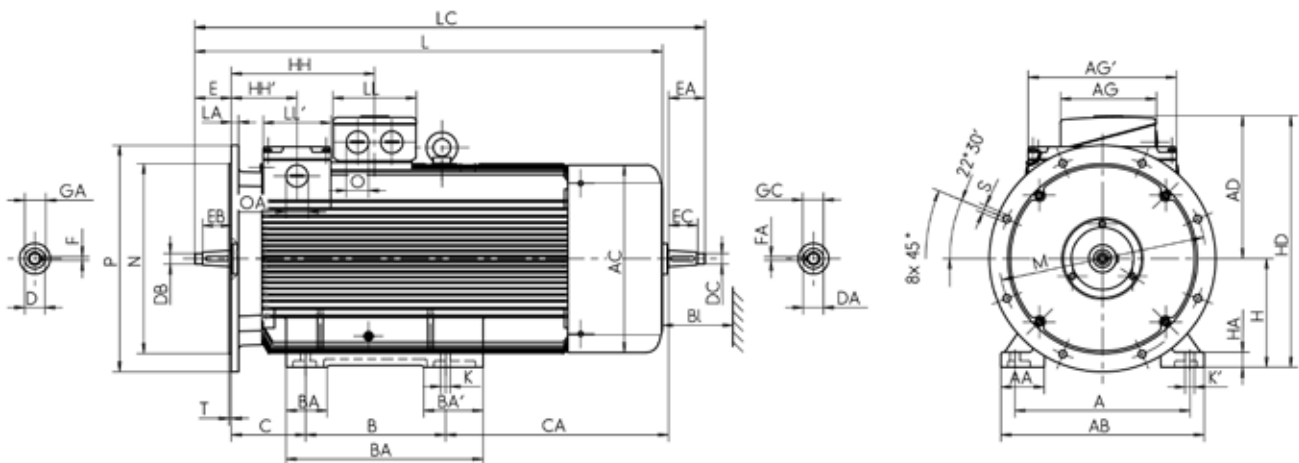

Type												Terminal box				Slip-ring compartment			Hole pattern					
	t	t tapered	t1	t1 tapered	h	c	p	s	s'	k	k1	A (IM B3)	A (IM B5)	A1	Type	x	z	r	x'	z'	r'	BI	Hole pattern	NDE possible
SPEH 132 M	41	39	41	39	132	16	331	12	12	643	727	242	242	-	25 A	156	145	M32 x 1.5	221	120	M32 x 1.5	35	4	no
SPEH 132 MX	41	39	41	39	132	16	331	12	12	643	727	242	242	-	25 A	156	145	M32 x 1.5	221	120	M32 x 1.5	35	4	no
SPEH 160 M	45	42.9	45	42.9	160	18	402	15	15	762	877	292	292	-	63 A	193	167	M40 x 1.5	272	140	M40 x 1.5	35	4	no
SPEH 160 L	45	42.9	45	42.9	160	18	402	15	15	762	877	292	292	-	63 A	193	167	M40 x 1.5	272	140	M40 x 1.5	35	4	no
SPEH 180 L	51.5	48.9	51.5	48.9	180	20	441	15	15	819	935	301	301	-	63 A	193	167	M40 x 1.5	292	140	M40 x 1.5	35	4	no
SPEH 200 L	59	56.4	59	56.4	200	22	500	19	19	927	1051	331	331	-	100 A	213	207	M50 x 1.5	310	145	M50 x 1.5	40	4	no
SPEH 200 LX	59	56.4	59	56.4	200	22	500	19	19	927	1051	331	331	-	100 A	213	207	M50 x 1.5	310	145	M50 x 1.5	40	4	no
SPEH 225 M	64	61.4	64	61.4	225	25	525	19	19	957	1081	331	331	-	100 A	213	207	M50 x 1.5	310	145	M50 x 1.5	40	8	yes
SPEH 225 MX	64	61.4	64	61.4	225	25	525	19	19	957	1081	331	331	-	100 A	213	207	M50 x 1.5	310	145	M50 x 1.5	40	8	yes
SPEH 250 M	74.5	71.4	74.5	71.4	250	28	576	24	24	1072	1224	342	342	-	100 A	213	207	M50 x 1.5	382	195	M50 x 1.5	45	8	yes
S11H 250 MX6	74.5	71.4	74.5	71.4	250	28	636	24	24	1166	1321	411	411	-	200 A	282	242	M63 x 1.5	382	195	M63 x 1.5	50	8L	yes
S11H 280 S4	85	81.2	85	81.2	280	40	696	24	30	1201	1350	411	411	-	200 A	282	242	M63 x 1.5	382	195	M63 x 1.5	50	8L	yes
S11H 280 S8	85	81.2	85	81.2	280	40	696	24	30	1281	1430	411	411	-	200 A	282	242	M63 x 1.5	382	195	M63 x 1.5	50	8L	yes
S11H 280 M4	85	81.2	85	81.2	280	40	696	24	30	1281	1430	411	411	-	200 A	282	242	M63 x 1.5	382	195	M63 x 1.5	50	8L	yes
S11H 280 M6	85	81.2	85	81.2	280	40	696	24	30	1281	1430	411	411	-	200 A	282	242	M63 x 1.5	382	195	M63 x 1.5	50	8L	yes
S11H 315 S4	95	91.7	95	91.7	315	44	731	28	35	1348	1515	416	416	-	200 A	282	242	M63 x 1.5	430	195	M63 x 1.5	55	8L	yes
S11H 315 S6	95	91.7	95	91.7	315	44	731	28	35	1428	1595	416	416	-	200 A	282	242	M63 x 1.5	430	195	M63 x 1.5	55	8L	yes
S11H 315 M	95	91.7	95	91.7	315	44	731	28	35	1428	1595	416	416	-	200 A	282	242	M63 x 1.5	430	195	M63 x 1.5	55	8L	yes

Three-phase motors with slip-ring rotor
Basic version SPEH 132–250/S11H 250–315 M

with surface cooling, type of cooling IC 411, degree of protection IP 54/IP 55

Type of construction IM B5 [IM 3001], IM 3002 up to size 200, IM V1 [IM 3011], IM 3012

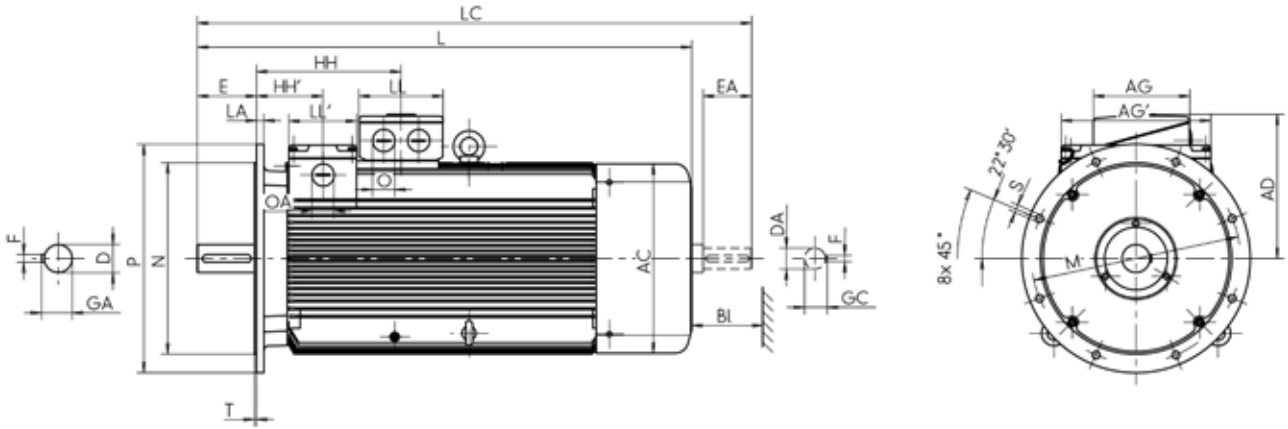

Type of construction IM B5K [IM 3003], IM 3004; up to size 200, IM V1K [IM 3013], IM 3014
 Tapered shaft end to DIN 1448, taper 1:10

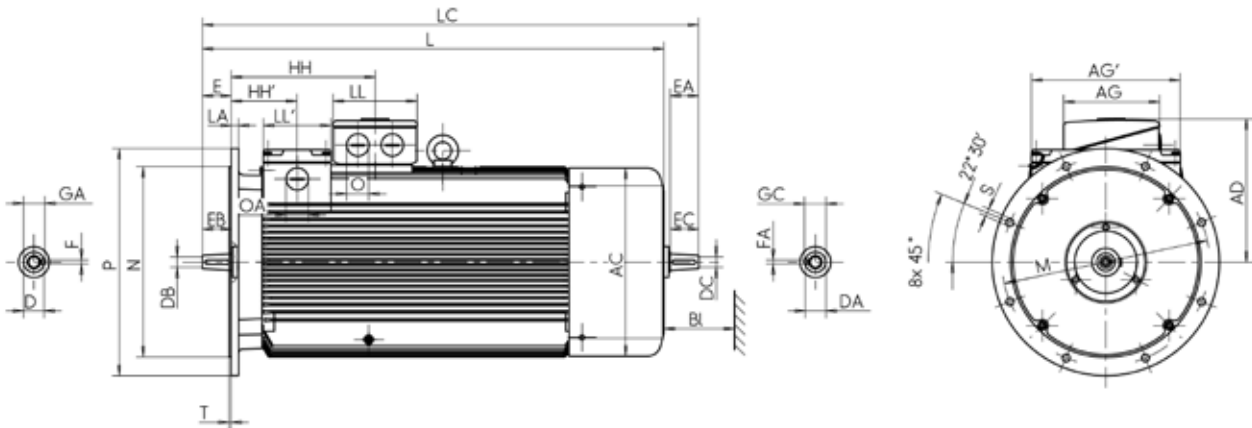

Three-phase motors with slip-ring rotor
Basic version S11H 315 MX-LY

with surface cooling, type of cooling IC 411, degree of protection IP 55

Type of construction IM B3 [IM 1001], IM 1002
 Cylindrical shaft end

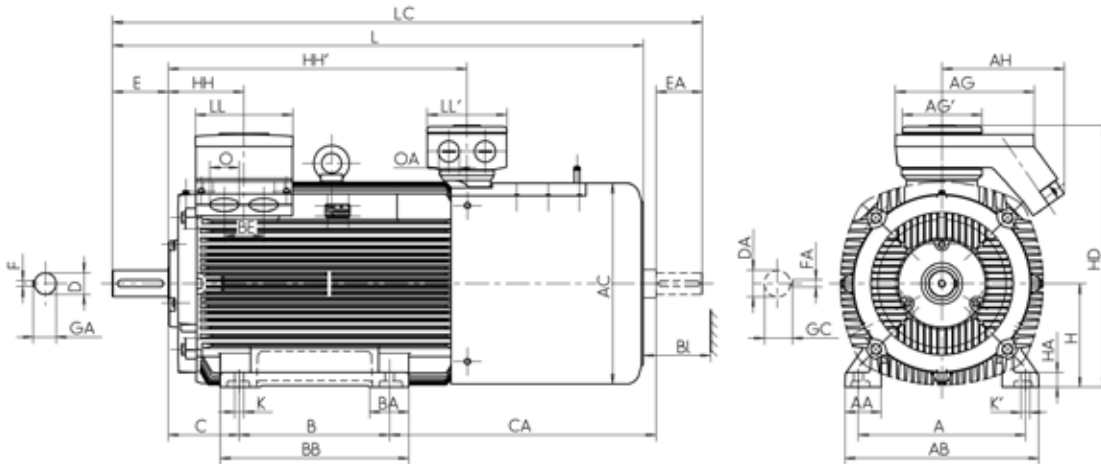

Type of construction IM B3K [IM 1003], IM 1004
 Tapered shaft end to DIN 1448, taper 1:10, with shoulder nut

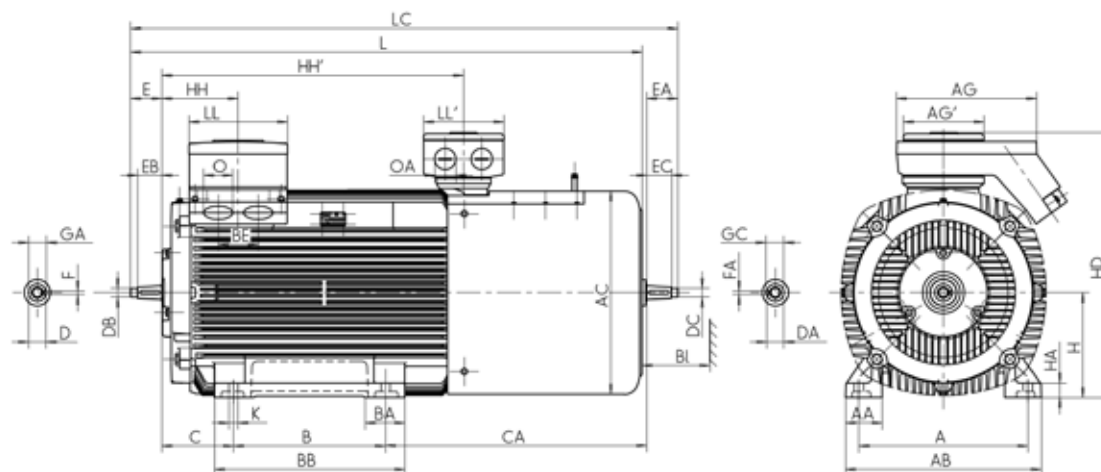

	-	-	A	AA	AB	AC	B	BA	BA'	BB	C	CA	D	DA	-	DB	DC	DIN	E	EA	F	FA	EB	EC	F	FA
	B5	B35	b	n	f	g	a	m	m1	e	w1	w2	d	d1	Centre hole DIN 332-DS	d2	d3		l	l1	u	u1	l2	l2	u	u1
S11H 315 MX4	A660	A660	508	110	590	610	457	120	120	573	216	810	90	70	M24	M64 x 4	M48 x 3	1448	170	140	25	20	130	105	22	18
S11H 315 MY4	A660	A660	508	110	590	610	457	120	120	573	216	810	90	70	M24	M64 x 4	M48 x 3	1448	170	140	25	20	130	105	22	18
S11H 315 LX4	A660	A660	508	110	590	610	508	120	120	624	216	879	90	70	M24	M64 x 4	M48 x 3	1448	170	140	25	20	130	105	22	18
S11H 315 LY4	A660	A660	508	110	590	610	508	120	120	624	216	879	90	70	M24	M64 x 4	M48 x 3	1448	170	140	25	20	130	105	22	18

Three-phase motors with slip-ring rotor Basic version S11H 315 MX-LY

with surface cooling, type of cooling IC 411, degree of protection IP 55

Type of construction IM B35 [IM 2001], IM 2002
Cylindrical shaft end

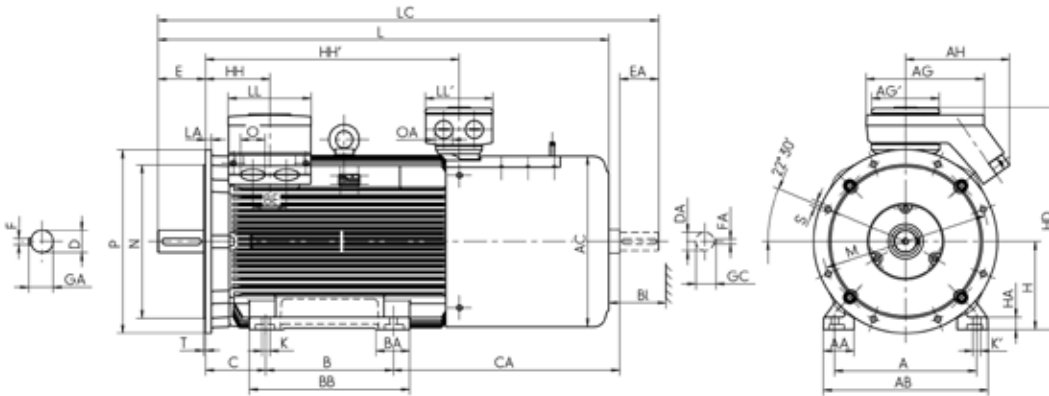

Type of construction IM B35K [IM 2003], IM 2004
Tapered shaft end to DIN 1448, taper 1:10, with shoulder nut

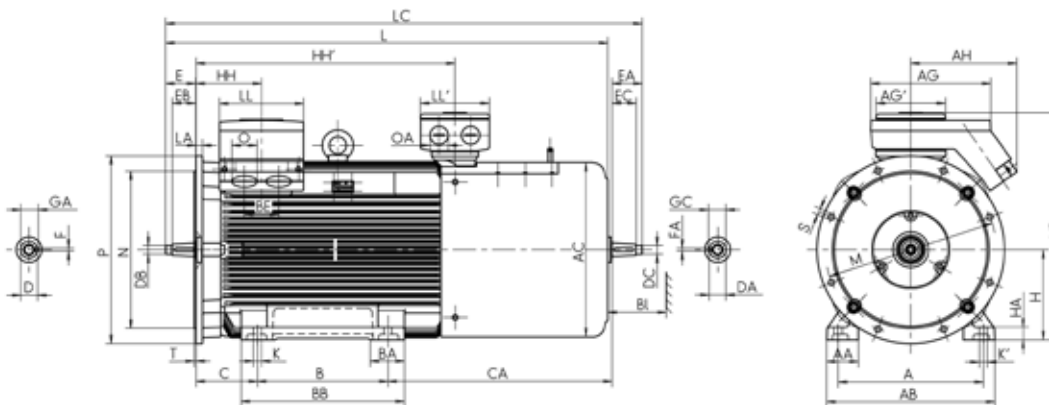

Type	GA	GA	GC	GC	H	HA	HD	K	K'	L	LC	LD	LD	LE	Terminal box			Slip-ring compartment			BI	Hole pattern	NDE possible		
	t	t tapered	t1	t1 tapered	h	c	p	s	s'	k	k1	A (IM B3)	A (IM B5)	A1	TB Type	x	z	r	Type	x'				z'	r'
S11H 315 MX4	95	91.7	74.5	71.4	315	44	800	28	35	1613	1793	230	230	675	VGK400 A	422	296	Ø 95	200A	282	242	M63 x1.5	55	8L	yes
S11H 315 MY4	95	91.7	74.5	71.4	315	44	800	28	35	1613	1793	230	230	675	VGK400 A	422	296	Ø 95	200A	282	242	M63 x1.5	55	8L	yes
S11H 315 LX4	95	91.7	74.5	71.4	315	44	800	28	35	1733	1913	230	230	795	VGK400 A	422	296	Ø 95	200A	282	242	M63 x1.5	55	8L	yes
S11H 315 LY4	95	91.7	74.5	71.4	315	44	800	28	35	1733	1913	230	230	795	VGK400 A	422	296	Ø 95	200A	282	242	M63 x1.5	55	8L	yes

**Three-phase motors with slip-ring rotor
Basic version S11H 315 MX-LY**

with surface cooling, type of cooling IC 411, degree of protection IP 55

Type of construction IM V1 [IM 3011]

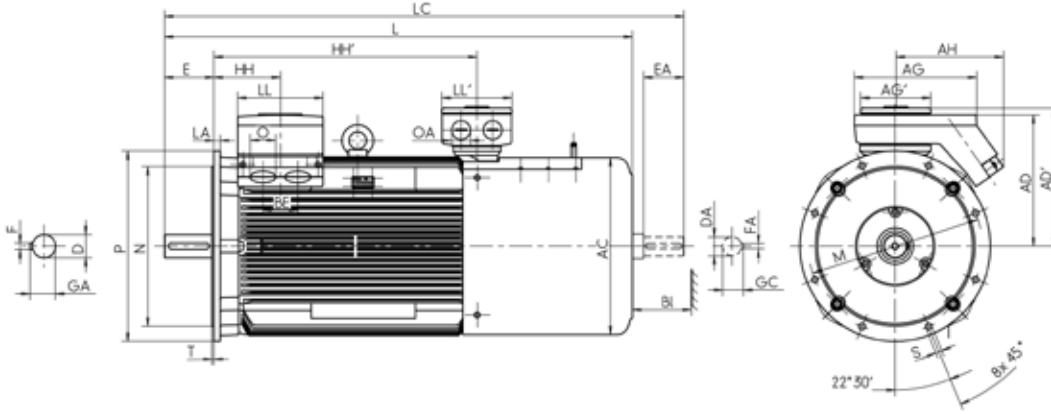

Type of construction IM B5K [IM 3003], IM 3004; up to size 200, IM V1K [IM 3013], IM 3014
Tapered shaft end to DIN 1448, taper 1:10

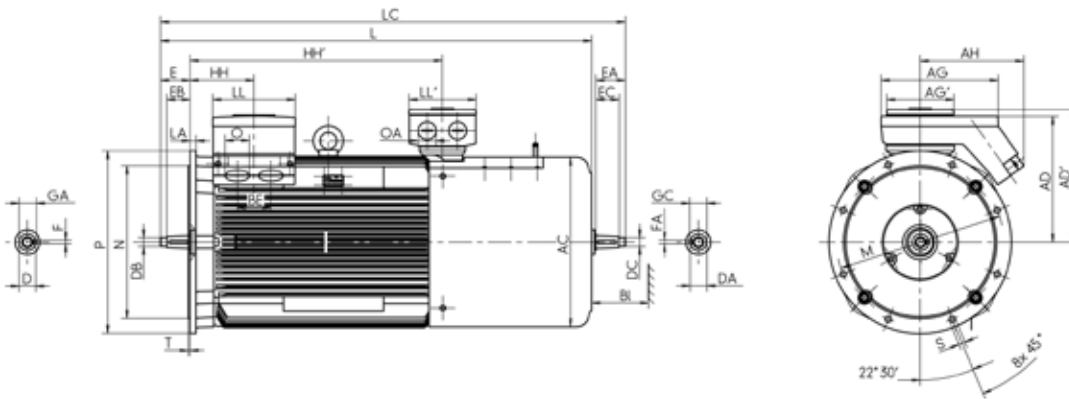

**Three-phase motors with slip-ring rotor
Basic version SPEH 132–160**

with surface cooling, type of cooling IC 411, degree of protection IP 54/IP 55

Type of construction IM B34 [IM 2101], IM 2102

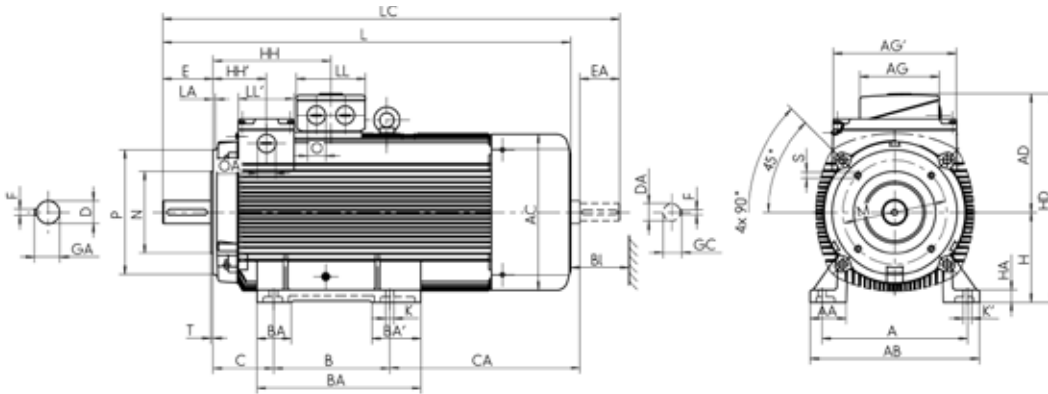

Type of construction IM B34K [IM 2103], IM 2104

Tapered shaft end to DIN 1448, taper 1:10, with shoulder nut

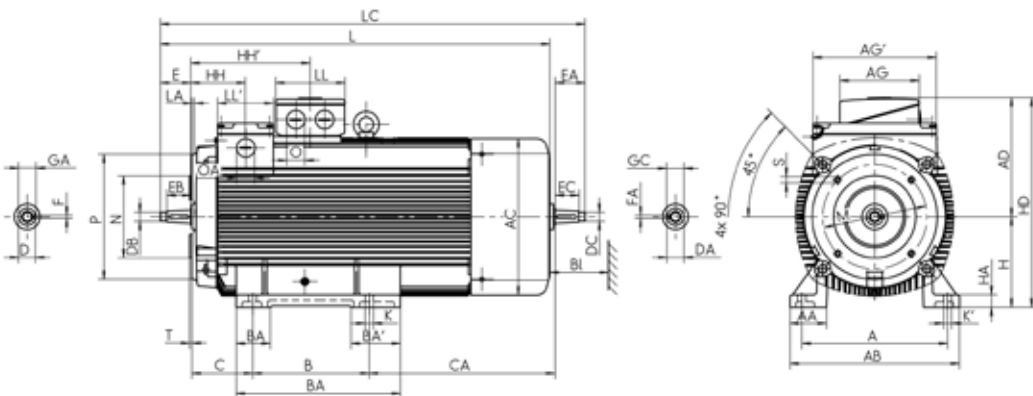

	-	-	A	AA	AB	AC	B	BA	BA'	BB	C	CA	D	DA	DB	DC	DIN	-	E	EA	F	FA	EB	EC	F	FA
	B14 K, B34 K	B14 G, B34 G	b	n	f	g	a	m	m1	e	w1	w2	d	d1	d2	d3	Centre hole DIN 332-DS	l	l1	u	u1	l2	l3	u	u1	
SPEH 132 M	C200	C250	216	50	256	258	178	55	55	218	89	300	38	38	M24 x 2	M24 x 2	1448	M12	80	80	10	10	58	58	6	6
SPEH 132 MX	C200	C250	216	50	256	258	178	55	55	218	89	300	38	38	M24 x 2	M24 x 2	1448	M12	80	80	10	10	58	58	6	6
SPEH 160 M	C250	C300	254	55	296	313	210	60	60	257	108	339	42	42	M24 x 2	M24 x 2	1448	M16	110	110	12	12	82	82	10	10
SPEH 160 L	C250	C300	254	55	296	313	254	60	60	301	108	305	42	42	M24 x 2	M24 x 2	1448	M16	110	110	12	12	82	82	10	10

Three-phase motors with slip-ring rotor Basic version SPEH 132–160

with surface cooling, type of cooling IC 411, degree of protection IP 54/IP 55

Type of construction IM B14 [IM 3601], IM 3602

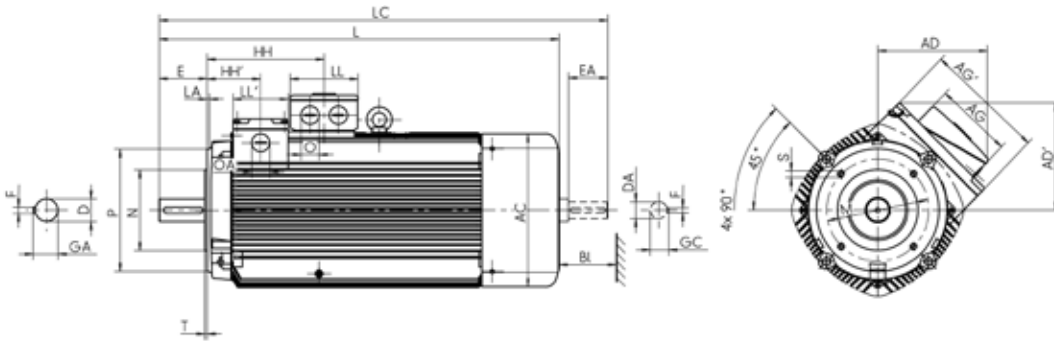

Type of construction IM B14K [IM 3603], IM 3604

Tapered shaft end to DIN 1448, taper 1:10, with shoulder nut

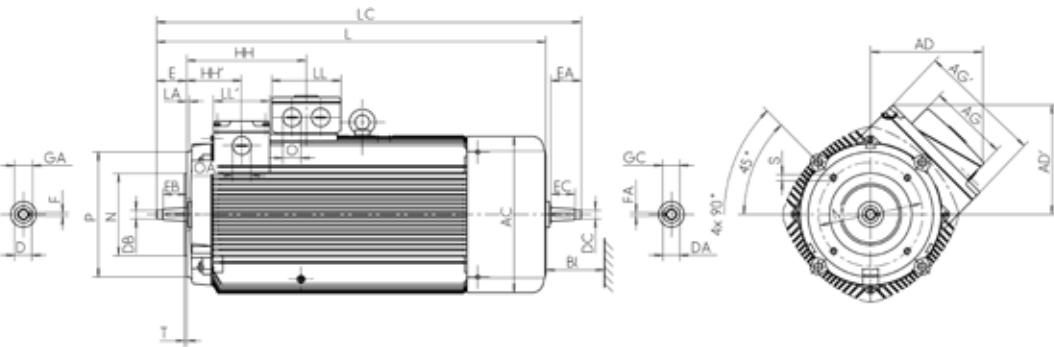

Type	GA	GA	GC	GC	H	HA	HD	K	K'	L	LC	LD	LD	LE	Terminal box			Slip-ring compartment			Hole pattern			
	t	t tapered	t1	t1 tapered	h	c	p	s	s'	k	k1	A (IM B14 K)	A (IM B14 G)	A1	TB Type	x	z	r	x'	z'	r'	BI	Hole pattern	NDE possible
SPEH 132 M	41	39	41	39	132	16	331	12	12	643	727	242	242	-	25 A	156	145	M32 x 1.5	221	120	M32 x 1.5	35	4	no
SPEH 132 MX	41	39	41	39	132	16	331	12	12	643	727	242	242	-	25 A	156	122	M32 x 1.5	221	120	M32 x 1.5	35	4	no
SPEH 160 M	45	42.9	45	42.9	160	18	402	15	15	762	877	292	292	-	63 A	193	167	M40 x 1.5	272	140	M40 x 1.5	35	4	no
SPEH 160 L	45	42.9	45	42.9	160	18	402	15	15	762	877	292	292	-	63 A	193	167	M40 x 1.5	272	140	M40 x 1.5	35	4	no

**Three-phase motors with slip-ring rotor
Basic version SPH/S10H 132–280**

with surface cooling, type of cooling IC 411, degree of protection IP 54/IP 55

Type of construction IM B3 [IM 1001], IM 1002

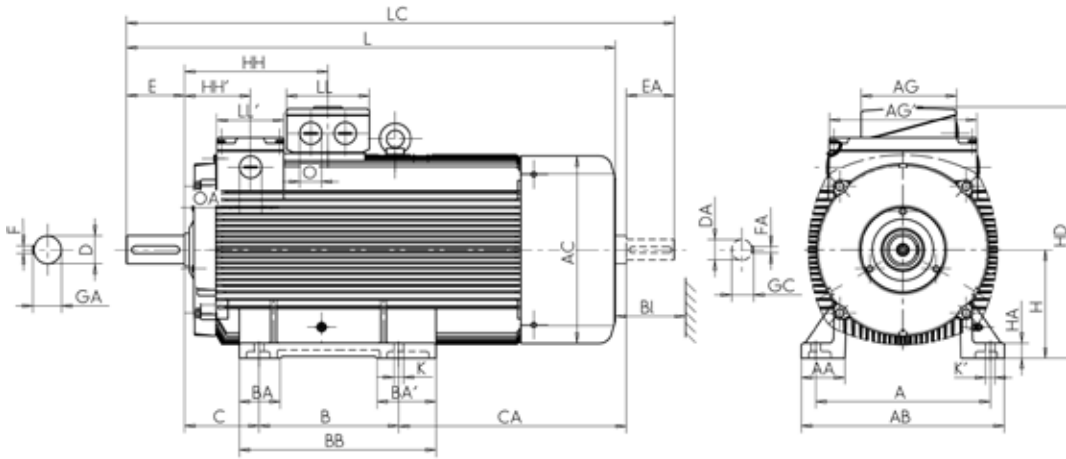

Type of construction IM B3K [IM 1003], IM 1004

Tapered shaft end to DIN 1448, taper 1:10, with shoulder nut

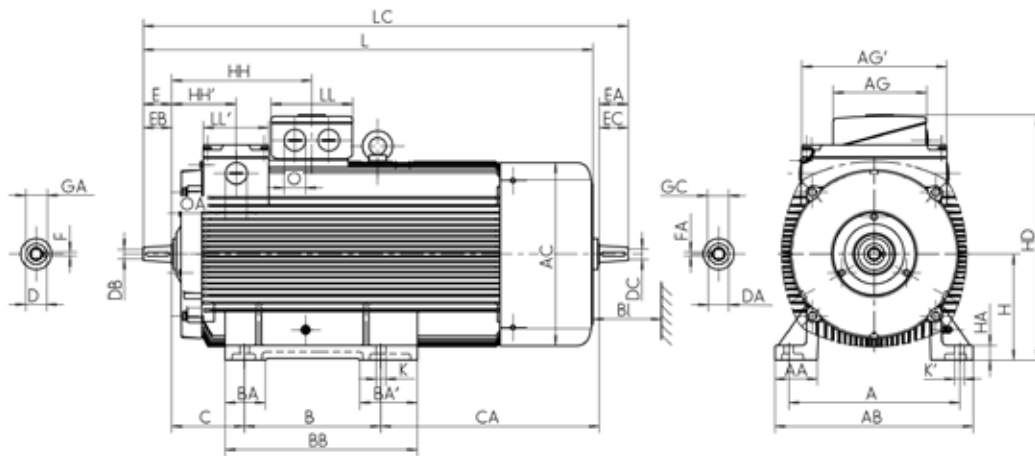

						A	AA	AB	AC	B	BA	BA'	BB	C	CA	HA	D	DA	-	E	EA	F	FA
Type	B5	B35	B14 K, B34 K	B14 G, B34 G	b	n	f	g	a	m	m1	e	w1	w2	c	d	d1	Centre hole	l	l1	u	u1	
SPH 132 M	A350	A350	C200	C250	216	50	256	258	178	55	55	218	89	300	16	38	38	M12	80	80	10	10	
SPH 132 L	A350	A350	C200	C250	216	50	256	258	203	55	55	243	89	313	16	38	38	M12	80	80	10	10	
SPH 160 M	A350	A400	C250	C300	254	55	296	313	210	60	60	257	108	339	18	48	42	M16	110	110	14	12	
SPH 160 L	A350	A400	C250	C300	254	55	296	313	254	60	60	301	108	325	18	48	42	M16	110	110	14	12	
SPH 180 M	A400	A450	-	-	279	62	328	351	241	65	65	288	121	353	20	55	48	M16	110	110	16	14	
SPH 180 L	A400	A450	-	-	279	62	328	351	279	65	65	326	121	371	20	55	48	M16	110	110	16	14	
SPH 200 M	A450	A450	-	-	318	70	372	390	267	70	70	322	133	431	22	60	55	M20	140	110	18	16	
SPH 200 L	A450	A450	-	-	318	70	372	390	305	70	70	360	133	453	22	60	55	M20	140	110	18	16	
SPH 225 M	A550	A550	-	-	356	75	413	440	311	75	75	368	149	481	25	65	55	M20	140	110	18	16	
S10H 250 M	A550	A550	-	-	406	80	470	490	349	-	-	412	168	524	40	75	65	M20	140	140	20	18	
S10H 250 L	A550	A550	-	-	406	80	470	490	406	-	-	469	168	547	40	75	65	M20	140	140	20	18	
S10H 280 M	A660	A660	-	-	457	88	522	550	419	-	-	482	190	596	40	80	70	M20	170	140	22	20	
S10H 280 L	A660	A660	-	-	457	88	522	550	457	-	-	520	190	638	40	80	70	M20	170	140	22	20	

Three-phase motors with slip-ring rotor Basic version SPH/S10H 132-280

with surface cooling, type of cooling IC 411, degree of protection IP 54/IP 55

Type of construction IM B3 [IM 1001], IM 1002

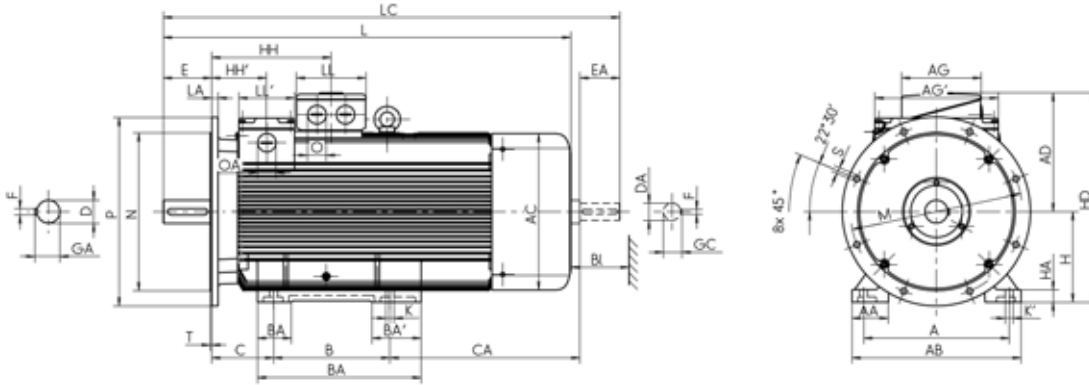

Type of construction IM B3K [IM 1003], IM 1004

Tapered shaft end to DIN 1449, taper 1:10, with shoulder nut

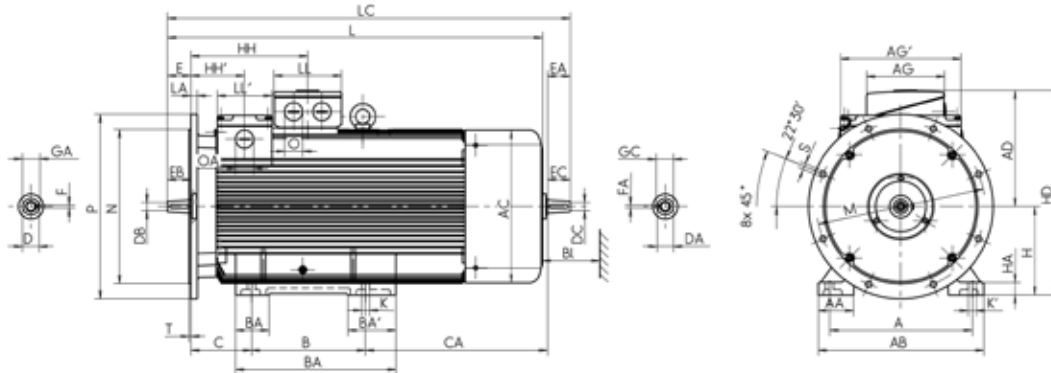

Type	GA	GC	H	HD	HD	K	K'	L	LC	LD	LD	LD	LD	AG	LL	O	AG'	LL'	OA	-	-	-	
	t	t1	h	p (B3)	p (B3 VIK KK)	s	s'	k	k1	A (IM B3)	A (IM B5)	A (IM B14 K)	A (IM B14 G)	Type	x	z	r	x'	z'	r'	BI	Hole pattern	NDE possible
SPH 132 M	41	41	132	331	331	12	12	643	727	242	242	242	242	25 A	156	145	M32 x 1.5	221	120	M32 x 1.5	35	4L	yes
SPH 132 L	41	41	132	331	331	12	12	681	765	242	242	242	242	25 A	156	145	M32 x 1.5	221	120	M32 x 1.5	35	4L	yes
SPH 160 M	51.5	45	160	402	402	15	15	762	877	292	292	292	292	63 A	193	167	M40 x 1.5	272	140	M40 x 1.5	35	4L	yes
SPH 160 L	51.5	45	160	402	402	15	15	792	907	292	292	292	292	63 A	193	167	M40 x 1.5	272	140	M40 x 1.5	35	4L	yes
SPH 180 M	59	51.5	180	441	441	15	15	819	935	301	301	301	301	63 A	193	167	M40 x 1.5	292	140	M40 x 1.5	35	8L	yes
SPH 180 L	59	51.5	180	441	441	15	15	875	991	301	301	301	301	100 A	213	207	M40 x 1.5	292	140	M40 x 1.5	35	8L	yes
SPH 200 M	64	59	200	500	500	19	19	957	1081	331	331	331	331	100 A	213	207	M50 x 1.5	310	145	M50 x 1.5	40	8L	yes
SPH 200 L	64	59	200	500	500	19	19	1017	1141	331	331	331	331	100 A	213	207	M50 x 1.5	310	145	M50 x 1.5	40	8L	yes
SPH 225 M	69	59	225	549	549	19	19	1069	1191	339	339	339	339	100 A	213	207	M50 x 1.5	382	195	M50 x 1.5	45	8L	yes
S10H 250 M	79.5	69	250	636	645	24	24	1166	1321	411	411	411	411	200 A	282	242	M63 x 1.5	382	195	M63 x 1.5	50	8L	yes
S10H 250 L	79.5	69	250	636	645	24	24	1246	1400	411	411	411	411	200 A	282	242	M63 x 1.5	382	195	M63 x 1.5	50	8L	yes
S10H 280 M	85	74.5	280	696	705	24	30	1363	1515	416	416	416	416	200 A	282	242	M63 x 1.5	430	195	M63 x 1.5	55	8L	yes
S10H 280 L	85	74.5	280	696	705	24	30	1443	1595	416	416	416	416	200 A	282	242	M63 x 1.5	430	195	M63 x 1.5	55	8L	yes

Three-phase motors with slip-ring rotor Basic version SPH/S10H 132–280

with surface cooling, type of cooling IC 411, degree of protection IP 54/IP 55

Type of construction IM B5 [IM 3001]

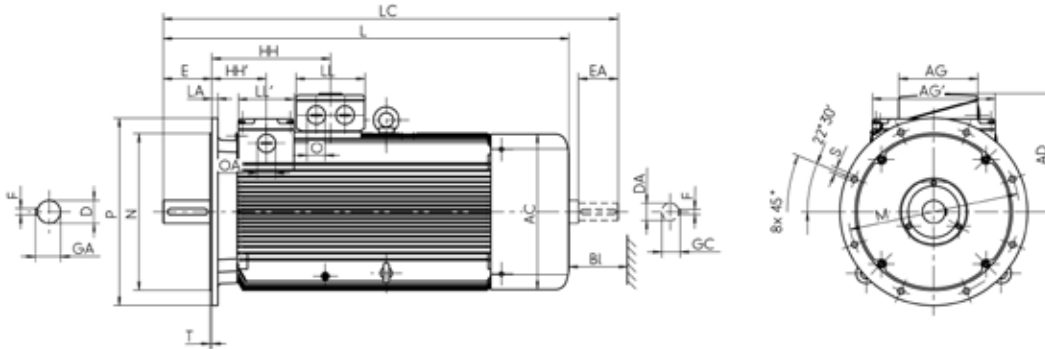

Type of construction IM B5K [IM 3003, IM 3004]

Tapered shaft end to DIN 1449, taper 1:10, with washer and fixing screw

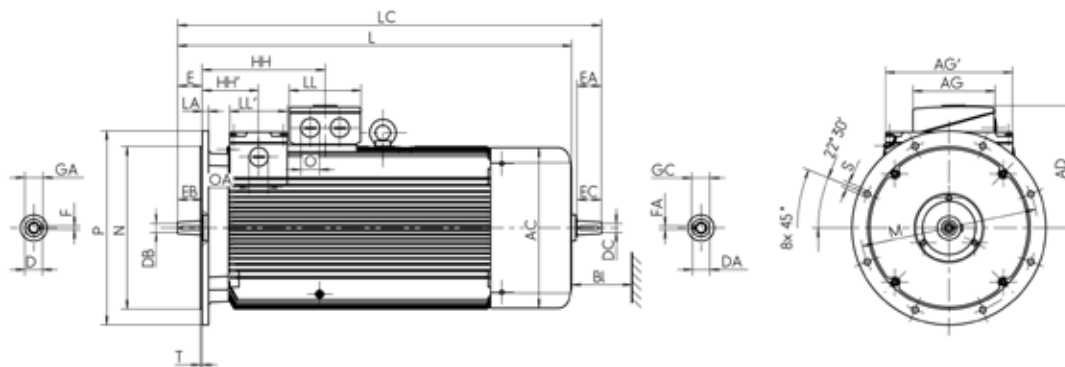

**Three-phase motors with slip-ring rotor
Basic version SPH 132–160**

with surface cooling, type of cooling IC 411, degree of protection IP 54/IP 55

Type of construction IM B34 [IM 2101], IM 2102

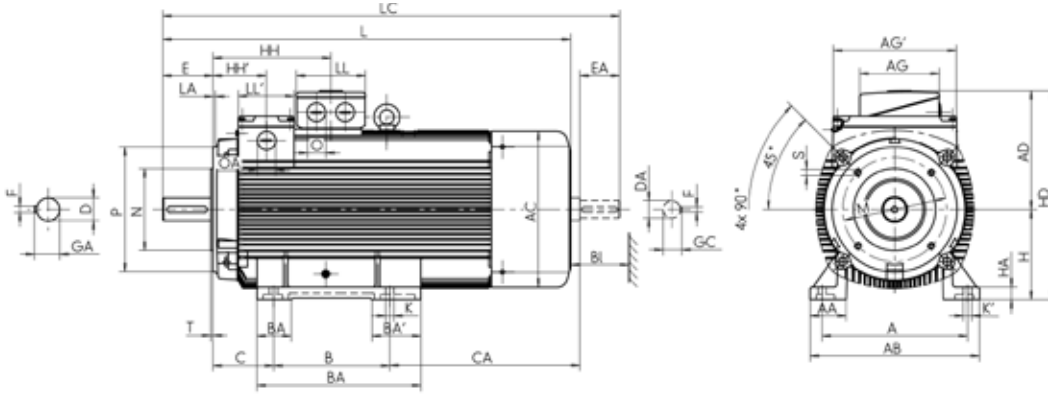

Type of construction IM B34K [IM 2103], IM 2104

Tapered shaft end to DIN 1449, taper 1:10, with washer and fixing screw

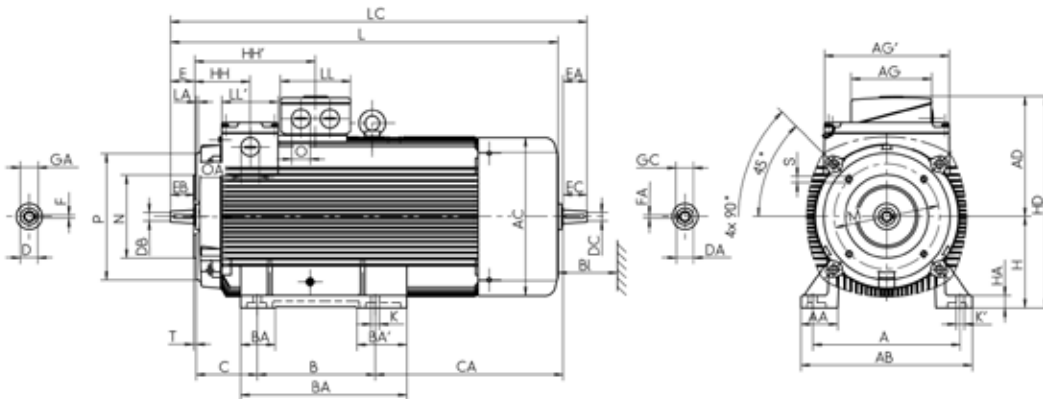

		-	A	AA	AB	AC	B	BA	BA'	BB	C	CA	HA	D	DA	-	E	EA	F	FA
B14 K, B34 K	B14 G, B34 G	Centre hole																		
		b	n	f	g	a	m	m1	e	w1	w2	c	d	d1	l	l1	u	u1		
SPH 132 M	C200 C250	216	50	256	258	178	55	55	55	218	89	300	16	38	38	M12	80	80	10	10
SPH 132 L	C200 C250	216	50	256	258	203	55	55	55	243	89	313	16	38	38	M12	80	80	10	10
SPH 160 M	C250 C300	254	55	296	313	210	60	60	60	257	108	339	18	48	42	M16	110	110	14	12
SPH 160 L	C250 C300	254	55	296	313	254	60	60	60	301	108	325	18	48	42	M16	110	110	14	12

Three-phase motors with slip-ring rotor Basic version SPH 132–160

with surface cooling, type of cooling IC 411, degree of protection IP 54/IP 55

Type of construction IM B14 [IM 3601], IM 3602

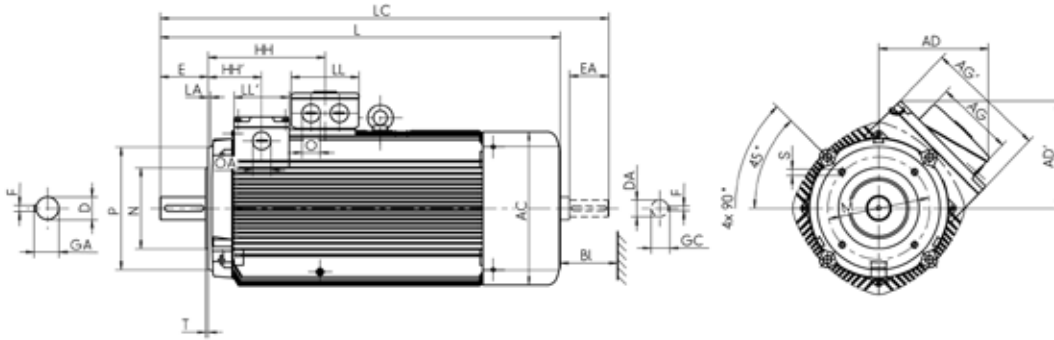

Type of construction IM B14K [IM 3603], IM 3604

Tapered shaft end to DIN 1449, taper 1:10, with washer and fixing screw

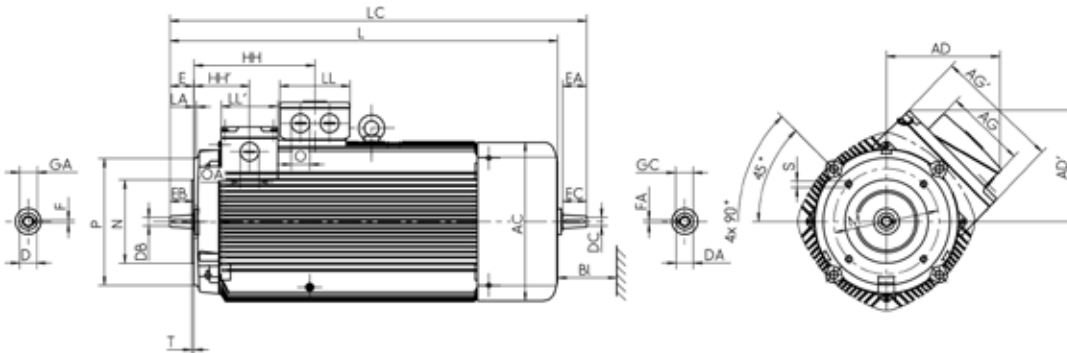

Type	GA	GC	H	HD	HD	K	K'	L	LC	LD	LD	Terminal box			Slip-ring compartment			- - -			
	t	t1	h	p (B3)	p (B3 VIK Kk)	s	s'	k	k1	A (IM B14 K)	A (IM B14 G)	Type	x	z	r	x'	z'	r'	BI	Hole pattern	NDE possible
SPH 132 M	41	41	132	331	331	12	12	643	727	242	242	25 A	156	145	M32 x 1.5	221	120	M32 x 1.5	35	4L	yes
SPH 132 L	41	41	132	331	331	12	12	681	765	242	242	25 A	156	145	M32 x 1.5	221	120	M32 x 1.5	35	4L	yes
SPH 160 M	51.5	45	160	402	402	15	15	762	877	292	292	63 A	193	167	M40 x 1.5	272	140	M40 x 1.5	35	4L	yes
SPH 160 L	51.5	45	160	402	402	15	15	792	907	292	292	63 A	193	167	M40 x 1.5	272	140	M40 x 1.5	35	4L	yes



VEM  MOTOR

Built-in motors

Contents

Product description	7/2
Overview of technical data	7/3
Motor selection data	
Series W4.R	
(corresponds to Efficiency IE3)	7/4
Series WE.R	
(corresponds to High Efficiency IE2)	7/6
Series K2.R	
(corresponds to Standard Efficiency IE1)	7/8
Dimensions	7/10

Product description

It is not always possible to mount or couple a drive motor with a standard foot or flange construction. For such machines, it is recommended to use a built-in motor from the

VEM standard series and to incorporate this motor directly. Built-in motors comprise a stator core with winding and a die-cast rotor body with or without shaft.

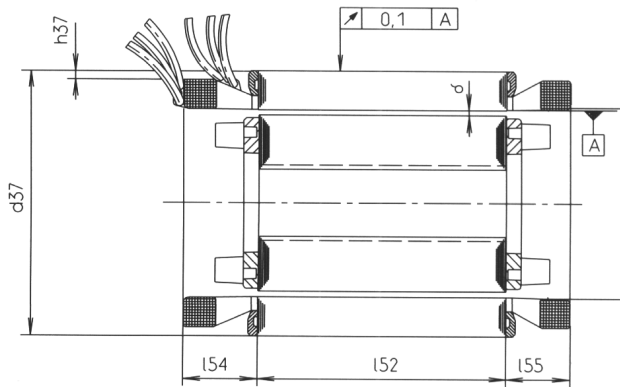

Built-in motor without shaft

Built-in motors achieve the same output and operating parameters as the corresponding motors of the basic series, subject to equivalent installation and cooling conditions after incorporation into the machine. As this is rarely the case, however, detailed rating plate data can only be specified after testing of the final product.

The fit of the stator housing is dependent on the material used. Minimum clearances must be observed between the winding overhang and the machine housing. The length of the connecting cable must be clarified before ordering.

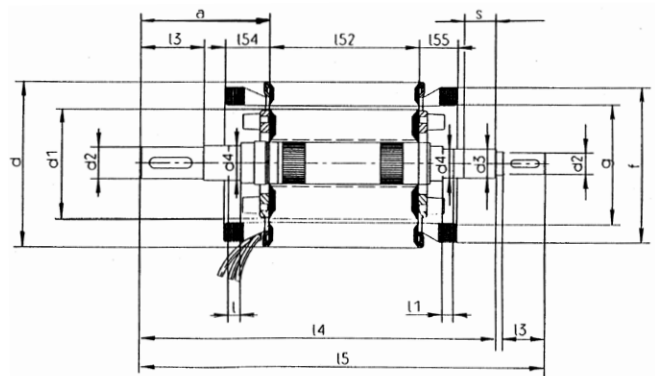

Built-in motor with shaft

Under normal circumstances, the rotor body is not machined. After pressing the rotor body onto the shaft, the outer diameter must be turned to the required final dimensions and the completed rotor must be balanced dynamically. The motor bearing design should correspond to that of the VEM standard series as far as possible.

Where built-in motors are to be used in special versions, such as semi-hermetic, transformer oil or wastewater pumps or the like, the specific installation and operating demands must be clarified before ordering.

Overview of technical data

The most important technical data are summarised in the following table. Further information can be taken from the catalogue section "Introduction" (chapter 1).

Product group	Squirrel-cage rotor, IEC/DIN
Rated output	0.06 to 710 kW
Sizes	56 to 400
Efficiency classification/ efficiency determination	Suitable for IE1, IE2 or IE3 to IEC/EN 60034-30-1, binding efficiency classification dependent on the circumstances of incorporation into the final product
Housing material	Not applicable, motor for incorporation, without own housing
Rated torque	0.25 to 5768 Nm
Method of connection	Single-speed motors are designed in star-delta configuration as standard.
Stator winding insulation	Thermal class 155, optional 155 [F(B)], 180 to IEC/EN 60034-1
Degree of protection	IP 00 to IEC/EN 60034-5, motor for incorporation, protection must be realised by the customer
Type of cooling	Not defined, cooling must be realised by the customer
Coolant temperature/ installation altitude	Standard -20 °C to +40 °C, Altitude 1000 m above sea level
Rated voltage	Standard voltages to EN 60038 50 Hz: 230 V, 400 V, 500 V, 690 V 60 Hz: 275 V, 460 V, 480 V, 600 V Voltage ranges A and B to IEC/EN 60034-1 (Prior consultation necessary regarding 230 V, 50 Hz and 275 V, 60 Hz for motors from size 315)
Type of construction	IM 5010
Paint finish	Not applicable
Vibration severity grade	Determined by the final product.
Shaft ends	to DIN 748 (IEC 60072), balanced with half-key, only applicable where a complete rotor is supplied
Limit speeds	Please refer to the section of "Limit speeds" in catalogue section "Motors for converter-fed operation", Chapter 4.
Bearing design	Please refer to the tables of "Bearing design data" in catalogue section „Standand motors“, Chapter 2.
Terminal boxes	Not applicable
Documentation	The operating and maintenance manuals of the final product must be observed.
Tolerances	Please refer to the section "Tolerances" in catalogue section "Introduction", Chapter 1.
Options	Please refer to the section "Overview of modifications" in catalogue section "Introduction", Chapter 1.

Motor selection data

Three-phase built-in motors based on Premium Efficiency IE3

Thermal class 155

Output assignments/principal dimensions							
Type	P _B kW	Stator outer diameter	Core length	Air gap	Stator [kg]	Weight	
		d ₃₇ [mm]	l ₅₂ [mm]	δ [mm]		Rotor body [kg]	Total [kg]
Synchronous speed 3000 rpm – 2-pole version							
W40R 132 MY2 E	7.5	206	137	0.60	23.2	8.6	32
W40R 160 S2 E	11	255	151	0.70	42.5	15.5	58
W40R 160 M2 E	15	255	190	0.70	52.5	19.1	72
W40R 160 MX2C E	18.5	255	220	0.70	61	30	91
W40R 180 M2C E	22	288	224	0.90	77	40	117
W40R 200 L2 E	30	322	250	1.00	114	40.9	155
W40R 200 L2C E	37	322	250	1.00	114	54	168
W40R 225 M2 E	45	362	247	1.20	114	50.8	165
W40R 250 S2 E	55	410	252	1.20	193	67.5	261
W40R 250 S2 E	75	410	252	1.20	193	67.5	261
W40R 250 M2 E	90	410	280	1.20	211	74.5	286
W40R 280 S2 E	110	465	300	1.45	290	104	394
W40R 280 M2 E	132	465	355	1.45	330	122	452
W40R 315 S2 E	160	465	435	1.45	400	150	550
W40R 315 M2 E	200	520	440	1.60	520	177	697
W40R 315 L2 E	250	520	570	1.60	660	233	893
W40R 315 LX2 E	315	520	690	1.60	775	280	1055
W40R 355 M2 E	355	610	420	1.90	680	251	931
W42R 355 MX2 E	400	610	465	1.90	915	310	1225
W42R 355 L2 E	500	610	700	1.90	1075	381	1456
W42R 400 M2 E	560	700	562	2.00	1330	449	1779
W42R 400 MX2 E	630	700	622	2.00	1460	498	1958
W42R 400 L2 E	710	700	692	2.00	1565	533	2098
Synchronous speed 1500 rpm – 4-pole version							
W40R 132 M4 E	5.5	206	194	0.45	27	13.7	41
W40R 132 MX4 E	7.5	206	240	0.45	33.4	17	50
W40R 160 S4 E	11	255	165	0.45	37	18.8	56
W40R 160 L4C E	15	255	250	0.45	60	38.5	99
W40R 180 M4 E	18.5	288	248	0.55	70.5	33.4	104
W40R 180 MX4 E	22	288	300	0.55	85.5	40.4	126
W40R 200 L4C E	30	322	290	0.65	112	71.5	184
W40R 200 LX4C E	37	322	330	0.65	128	81.5	210
W40R 225 MX4 E	45	362	340	0.70	136	76.5	213
W40R 250 S4 E	55	410	310	0.80	194	91.5	286
W40R 250 M4 E	75	410	364	0.80	227	107	334
W40R 280 S4 E	90	465	345	1.00	275	138	413
W40R 280 S4 E	110	465	345	1.00	275	159	434
W40R 280 M4 E	132	465	400	1.00	310	159	469
W40R 315 S4 E	160	465	480	1.10	360	191	551
W40R 315 M4 E	200	520	480	1.00	450	260	710
W40R 315 L4 E	250	520	600	1.00	550	364	914
W40R 315 LX4 E	315	520	690	1.00	620	374	994
W40R 355 M4 E	355	610	590	1.50	850	357	1207
W42R 355 MX4 E	400	610	712	1.50	990	419	1409
W42R 355 L4 E	500	610	752	1.50	1045	442	1487
W42R 400 M4 E	560	700	542	1.60	1130	437	1567
W42R 400 MX4 E	630	700	612	1.60	1265	489	1754
W42R 400 L4 E	710	700	697	1.60	1390	519	1909

Three-phase built-in motors based on Premium Efficiency IE3

Thermal class 155

Output assignments/principal dimensions							
Type	P _B kW	Stator outer diameter	Core length	Air gap	Stator [kg]	Rotor body [kg]	Total [kg]
		d ₃₇ [mm]	l ₅₂ [mm]	δ [mm]			
Synchronous speed 1000 rpm – 6-pole version							
W40R 132 S6 E	4	206	151	0.35	19.5	13.9	33
W40R 132 MX6 E	5.5	206	240	0.35	30.9	21.7	53
W40R 160 M6 E	7.5	255	210	0.40	41.5	33.8	75
W40R 160 L6C E	11	255	240	0.40	47.5	48.4	96
W40R 180 M6C E	15	288	248	0.45	57	58	115
W40R 200 L6 E	18.5	322	290	0.45	93	68	161
W40R 200 L6C E	22	322	290	0.45	93	85.5	179
W40R 225 MX6 E	30	362	290	0.50	89	89.5	179
W40R 250 M6 E	37	410	315	0.55	162	123	285
W40R 280 S6 E	45	465	300	0.70	220	159	379
W40R 280 M6 E	55	465	380	0.70	260	197	457
W40R 315 S6 E	75	520	370	0.70	305	213	518
W40R 315 M6 E	90	520	400	0.70	320	206	526
W40R 315 L6 E	110	520	450	0.70	380	350	730
W40R 315 LX6 E	132	520	580	0.70	460	398	858
W40R 355 M6 E	160	610	480	0.90	610	389	999
W42R 355 MX6 E	200	610	595	0.90	865	524	1389
W42R 355 LY6 E	250	610	720	0.90	905	558	1463
W42R 355 L6 E	315	610	720	0.90	915	558	1473
W42R 355 LX6 E	355	610	720	0.90	915	558	1473
W42R 355 LZ6 E	400	610	720	0.90	915	558	1473
W42R 400 MY6 E	355	610	595	0.90	1220	563	1783
W42R 400 M6 E	400	700	595	0.90	1230	563	1793
W42R 400 MX6 E	450	700	562	1.00	1105	644	1749
W42R 400 L6 E	500	700	622	1.00	1190	703	1893
W42R 400 LX6 E	560	700	697	1.00	1200	703	1903
Synchronous speed 750 rpm – 8-pole version							
W40R 132 S8 E	3	206	151	0.35	19.5	13.9	33
W40R 132 MX8 E	4	206	240	0.35	29.7	21.7	51
W40R 160 M8 E	5.5	255	210	0.40	41.5	33.8	75
W40R 160 L8 E	7.5	255	240	0.40	46.5	38.5	85
W40R 180 M8 E	11	288	248	0.45	57	45.8	103
W40R 180 MX8 E	15	288	294	0.45	67.5	55.5	123
W40R 200 L8 E	18.5	322	290	0.45	89.5	68	158
W40R 225 MX8 E	22	362	290	0.50	86	89.5	176
W40R 250 M8 E	30	410	315	0.55	159	123	282
W40R 280 S8 E	37	465	300	0.70	220	159	379
W40R 280 M8 E	45	465	380	0.70	260	197	457
W40R 315 S8 E	55	465	410	0.70	270	213	483
W40R 315 M8 E	75	520	400	0.70	320	206	526
W40R 315 L8 E	90	520	450	0.70	380	350	730
W40R 315 LX8 E	110	520	580	0.70	460	398	858
W40R 355 MY8 E	132	610	430	0.80	510	336	846
W40R 355 M8 E	160	610	480	0.80	580	408	988
W42R 355 MX8 E	250	610	672	0.80	820	559	1379
W42R 355 L8 E	315	610	732	0.80	890	615	1505
W42R 400 M8 E	355	700	607	0.90	920	562	1482
W42R 400 MX8 E	400	700	672	0.90	1100	643	1743
W42R 400 L8 E	450	700	740	0.90	1170	701	1871

Three-phase built-in motors based on High Efficiency IE2

Thermal class 155

Output assignments/principal dimensions							
Type	P _B kW	Stator outer diameter	Core length	Air gap	Stator [kg]	Weight	
		d ₃₇ [mm]	l ₅₂ [mm]	δ [mm]		Rotor body [kg]	Total [kg]
Synchronous speed 3000 rpm – 2-pole version							
W10R 132 MY2 E	7.5	206	137	0.60	23.2	8.6	31.80
W10R 160 S2 E	11.0	255	151	0.70	42.5	15.5	58.00
W10R 160 M2 E	15.0	255	190	0.70	52.5	19.1	71.60
W10R 160 M2 E	18.5	255	190	0.70	52.5	19.1	71.60
W10R 180 S2 E	22	288	174	0.90	61.5	23.6	85.10
W10R 180 M2 E	30	288	224	0.90	77.0	29.7	106.70
W10R 180 MX2 E	37	288	270	0.90	93	35.8	128.80
W10R 200 L2 E	45	322	250	1.00	114	40.9	154.40
W10R 225 M2 E	55	362	247	1.20	146	50.8	196.30
W10R 250 S2 E	75	410	252	1.20	193	67.5	260.50
W10R 250 M2 E	90	410	280	1.20	211	74.5	285.50
W10R 280 S2 E	110	465	300	1.45	290	104	394.00
W10R 280 M2 E	132	465	355	1.45	330	122	452.00
W10R 315 S2 E	160	465	435	1.45	400	150	550.00
W10R 315 M2 E	200	520	440	1.60	520	177	697.00
W10R 315 L2 E	250	520	570	1.60	660	233	893.00
W10R 315 LX2 E	315	520	690	1.60	775	280	1055.00
W22R 355 MY2 E	315	610	420	1.90	680	229	909.00
W22R 355 M2 E	355	610	465	1.90	750	251	1001.00
Synchronous speed 1500 rpm – 4-pole version							
W10R 132 M4 E	5.5	206	194	0.45	27.0	13.7	40.70
W10R 132 M4 E	7.5	206	194	0.45	27.0	13.7	40.70
W10R 132 MX4 E	11.0	206	240	0.45	33.4	17.0	50.40
W10R 160 S4 E	11.0	255	165	0.45	37.0	18.8	55.80
W10R 160 L4 E	15.0	255	250	0.45	60.0	28.3	88.30
W10R 180 S4 E	18.5	288	191	0.55	55.5	26.2	81.70
W10R 180 M4 E	22	288	248	0.55	70.5	33.4	103.90
W10R 200 M4 E	30	322	250	0.65	96.5	47.8	144.30
W10R 200 L4 E	37	322	290	0.65	112	54.5	166.50
W10R 200 LX4 E	45	322	330	0.65	127	62.0	189.00
W10R 225 M4 E	45	362	280	0.70	146	63.0	209.00
W10R 225 MX4 E	55	362	340	0.70	136	76.5	212.50
W10R 250 S4 E	55	410	310	0.80	194	91.5	285.50
W10R 250 S4 E	75	410	310	0.80	194	91.5	285.50
W10R 250 M4 E	90	410	364	0.80	227	107	334.00
W10R 280 S4 E	110	465	345	1.00	275	138	413.00
W10R 280 M4 E	132	465	400	1.00	310	159	469.00
W10R 315 S4 E	160	465	480	1.10	360	191	551.00
W10R 315 M4 E	200	520	480	1.00	450	260	710.00
W10R 315 L4 E	250	520	600	1.00	550	364	914.00
W10R 315 LX4 E	315	520	690	1.00	620	374	994.00
W22R 355 MY4 E	315	610	480	1.50	700	286	986.00
W22R 355 M4 E	355	610	590	1.50	850	357	1207.00

Three-phase built-in motors based on High Efficiency IE2

Thermal class 155

Output assignments/principal dimensions							
Type	P _B kW	Stator outer diameter	Core length	Air gap	Stator [kg]	Rotor body [kg]	Total [kg]
		d ₃₇ [mm]	l ₅₂ [mm]	δ [mm]			
Synchronous speed 1000 rpm – 6-pole version							
W10R 132 S6 E	4.0	206	151	0.35	19.5	13.9	33.40
W10R 132 M6 E	5.5	206	194	0.35	25.0	17.5	42.50
W10R 132 MX6 E	7.5	206	240	0.35	31.0	21.7	52.70
W10R 160 S6 E	7.5	255	160	0.40	33.0	26.2	59.20
W10R 160 M6 E	11.0	255	210	0.40	41.5	33.8	75.30
W10R 160 L6 E	15.0	255	240	0.40	47.5	38.6	86.10
W10R 180 S6 E	15.0	288	204	0.45	49.0	38.1	87.10
W10R 180 M6 E	18.5	288	248	0.45	57.0	45.8	102.80
W10R 180 MX6 E	22	288	294	0.45	67.5	55.5	123.00
W10R 200 M6 E	22	322	250	0.45	80	59.0	139.00
W10R 200 L6 E	30	322	290	0.45	93	68.0	161.00
W10R 225 M6 E	30	362	260	0.50	104	80.5	184.50
W10R 225 MX6 E	37	362	290	0.50	89.5	89.5	179.00
W10R 250 S6 E	37	410	252	0.55	133	100	233.00
W10R 250 M6 E	45	410	315	0.55	162	123	285.00
W10R 280 S6 E	55	465	300	0.70	220	159	379.00
W10R 280 M6 E	75	465	380	0.70	260	197	457.00
W10R 315 S6 E	90	465	410	0.70	270	213	483.00
W10R 315 L6 E	110	520	450	0.70	320	350	670.00
W10R 315 M6 E	132	520	450	0.70	320	350	670.00
W10R 315 LX6 E	160	520	580	0.70	460	398	858.00
W10R 315 LX6 E	200	520	580	0.70	460	398	858.00
W22R 355 MY6 E	200	610	430	0.90	590	349	939.00
W22R 355 M6 E	250	610	480	0.90	610	389	999.00
Synchronous speed 750 rpm – 8-pole version							
W10R 132 S8 E	3.0	206	151	0.35	19.5	13.9	33.40
W10R 132 M8 E	4.0	206	194	0.35	25.0	17.5	42.50
W10R 132 MX8 E	5.5	206	240	0.35	30.0	21.7	51.70
W10R 160 S8 E	5.5	255	160	0.40	33.0	26.2	59.20
W10R 160 M8 E	7.5	255	210	0.40	41.5	33.8	75.30
W10R 160 L8 E	11.0	255	240	0.40	46.5	38.6	85.10
W10R 180 S8 E	11.0	288	204	0.45	49.0	38.1	87.10
W10R 180 M8 E	15.0	288	248	0.45	57.0	45.8	102.80
W10R 180 MX8 E	18.5	288	294	0.45	67.5	55.5	123.00
W10R 200 M8 E	18.5	322	250	0.45	77.0	58.6	135.60
W10R 200 L8 E	22	322	290	0.45	89.5	68.0	157.50
W10R 225 M8 E	22	362	260	0.50	101	81	181.50
W10R 225 MX8 E	30	362	290	0.50	86.0	89.5	175.50
W10R 250 S8 E	30	410	252	0.55	129	100	229.00
W10R 250 M8 E	37	410	315	0.55	159	123	282.00
W10R 280 S8 E	55	465	300	0.70	220	159	379.00
W10R 280 M8 E	75	465	380	0.70	260	197	457.00
W10R 315 S8 E	90	465	410	0.70	270	213	483.00
W10R 315 M8 E	110	520	400	0.70	320	206	526.00
W10R 315 L8 E	132	520	450	0.70	380	350	730.00
W10R 315 LX8 E	160	520	580	0.70	460	398	858.00
W22R 355 MY8 E	160	610	430	0.80	510	336	846.00
W22R 355 M8 E	200	610	480	0.80	580	408	988.00

Three-phase built-in motors based on Standard Efficiency IE1

Thermal class 155

Output assignments/principal dimensions							
Type	P _B kW	Stator outer diameter d ₃₇ [mm]	Core length l ₅₂ [mm]	Air gap δ [mm]	Stator [kg]	Weight Rotor body [kg]	Total [kg]
Synchronous speed 3000 rpm – 2-pole version							
K20R 56 K2 E	0.18	84.0	37.0	0.25	1.32	0.39	1.71
K20R 56 G2 E	0.25	84.0	47.0	0.25	1.60	0.47	2.07
K20R 63 K2 E	0.37	96.0	43.0	0.25	1.95	0.58	2.53
K20R 63 G2 E	0.55	96.0	59.0	0.25	2.50	0.77	3.27
K20R 71 K2 E	0.75	110.0	60.0	0.30	3.40	0.96	4.36
K20R 71 G2 E	1.1	110.0	81.0	0.30	4.31	1.25	5.56
K20R 80 K2 E	1.5	126.0	80.0	0.35	5.78	1.65	7.43
K20R 80 G2 E	2.2	126.0	108.0	0.35	7.55	2.18	9.73
K20R 90 L2 E	3.0	140.0	110.0	0.45	9.55	2.95	12.50
K20R 100 S2 E	4.0	158.0	112.0	0.55	12.80	3.77	16.57
K20R 100 L2 E	5.5	158.0	146.0	0.55	16.30	4.82	21.12
K20R 112 MY2 E	5.5	176.0	122.0	0.60	16.0	5.0	21.00
K20R 112 M2 E	7.5	176.0	162.0	0.60	21.0	6.5	27.46
K10R 132 M2 E	11.0	206.0	162.0	0.60	27.0	10.0	36.96
K10R 160 S2 E	15.0	255.0	153.5	0.70	42.5	15.5	57.96
K10R 160 M2 E	18.5	255.0	192.5	0.70	52.5	19.1	71.58
K10R 180 S2 E	22	288.0	176.5	0.90	61.5	23.6	85.10
K10R 180 M2 E	30	288.0	226.5	0.90	77.0	29.7	106.70
K10R 200 M2 E	37	322.0	212.5	1.00	99.0	34.9	133.90
K10R 200 L2 E	45	322.0	252.5	1.00	113.5	40.9	154.40
K10R 225 M2 E	55	362.0	250.5	1.20	145.5	50.8	196.30
K10R 250 S2 E	75	410.0	255.0	1.20	192.5	67.3	259.80
K10R 250 M2 E	90	410.0	283.0	1.20	210.5	74.3	284.80
K10R 280 S2 E	110	465.0	306.0	1.45	290.0	104.0	394.00
K10R 280 M2 E	132	465.0	361.0	1.45	330.0	122.0	452.00
K10R 315 S2 E	160	465.0	441.0	1.45	400.0	150.0	550.00
K10R 315 M2 E	200	520.0	446.0	1.60	520.0	-	520.00
K10R 315 L2 E	250	520.0	576.0	1.60	660.0	-	660.00
K22R 355 MY2 E	315	610.0	432.0	1.90	680.0	-	680.00
K22R 355 M2 E	355	610.0	477.0	1.90	750.0	-	750.00
Synchronous speed 1500 rpm – 4-pole version							
K20R 56 K4 E	0.12	84.0	37.0	0.20	1.22	0.5	1.72
K20R 56 G4 E	0.18	84.0	49.0	0.20	1.52	0.63	2.15
K20R 63 K4 E	0.25	96.0	45.0	0.20	1.85	0.78	2.63
K20R 63 G4 E	0.37	96.0	62.0	0.20	2.43	1.05	3.48
K20R 71 K4 E	0.55	110.0	63.0	0.20	3.09	1.33	4.42
K20R 71 G4 E	0.75	110.0	81.0	0.20	3.88	1.66	5.54
K20R 80 K4 E	1.1	126.0	80.0	0.25	4.92	2.25	7.17
K20R 80 G4 E	1.5	126.0	104.0	0.25	6.23	2.88	9.11
K20R 90 L4 E	2.2	140.0	110.0	0.30	8.35	3.76	12.11
K20R 100 S4 E	3.0	158.0	112.0	0.35	10.60	5.21	15.81
K20R 100 L4 E	4.0	158.0	146.0	0.35	13.50	6.71	20.21
K20R 100 LX4 E	5.5	158.0	180	0.35	16.00	8.27	24.27
K20R 112 M4 E	5.5	176.0	142.0	0.35	15.0	7.1	22.07
K10R 132 S4 E	7.5	206.0	139.0	0.45	20.0	10.0	29.96
K10R 132 M4 E	11.0	206.0	196.0	0.45	27.0	13.7	40.70
K10R 160 S4 E	15.0	255.0	167.5	0.45	37.0	18.8	55.80
K10R 160 M4 E	18.5	255.0	197.5	0.45	46.5	22.0	68.52
K10R 180 S4 E	22	288.0	193.0	0.55	55.5	26.2	81.70
K10R 180 M4 E	30	288.0	250.5	0.55	70.5	33.4	103.90
K10R 200 M4 E	37	322.0	252.5	0.65	96.5	47.8	144.30
K10R 200 L4 E	45	322.0	292.5	0.65	112.0	54.5	166.50
K10R 225 M4 E	55	362.0	283.5	0.70	145.5	63.0	208.50
K10R 250 S4 E	75	410.0	313.0	0.80	193.5	91.2	284.70
K10R 250 M4 E	90	410.0	367.0	0.80	227.0	106.8	333.80
K10R 280 S4 E	110	465.0	351.0	1.00	275.0	138.0	413.00
K10R 280 M4 E	132	465.0	406.0	1.00	310.0	159.0	469.00
K10R 315 S4 E	160	465.0	486.0	1.10	360.0	191.0	551.00
K10R 315 M4 E	200	520.0	486.0	1.00	450.0	-	450.00
K10R 315 L4 E	250	520.0	606.0	1.00	550.0	-	550.00
K22R 355 MY4 E	315	610.0	492.0	1.50	720.0	-	720.00

Three-phase built-in motors based on Standard Efficiency IE1

Thermal class 155

Output assignments/principal dimensions							
Type	P _B kW	Stator outer diameter d ₃₇ [mm]	Core length l ₅₂ [mm]	Air gap δ [mm]	Stator [kg]	Weight Rotor body [kg]	Total [kg]
Synchronous speed 1000 rpm – 6-pole version							
K20R 56 K6 E	0.09	84.0	49.0	0.17	1.33	0.63	1.96
K20R 56 G6 E	0.12	84.0	62.0	0.17	1.83	0.79	2.62
K20R 63 K6 E	0.18	96.0	62.0	0.17	2.30	0.91	3.21
K20R 63 G6 E	0.25	96.0	76.0	0.17	2.83	1.25	4.08
K20R 71 K6 E	0.37	110.0	66.0	0.20	2.78	1.70	4.48
K20R 71 G6 E	0.55	110.0	91.0	0.20	3.75	2.33	6.08
K20R 80 K6 E	0.75	126.0	89.0	0.25	4.55	3.13	7.68
K20R 80 G6 E	1.1	126.0	120.0	0.25	6.07	4.15	10.22
K20R 90 L6 E	1.5	140.0	120.0	0.25	7.45	5.13	12.58
K20R 100 L6 E	2.2	158.0	139.0	0.30	10.70	7.63	18.33
K20R 112 M6 E	3.0	176.0	122.0	0.30	12.0	8.2	20.21
K20R 112 MX6 E	4.0	176.0	162.0	0.30	15.5	10.8	26.25
K10R 132 S6 E	5.5	206.0	153.0	0.35	19.5	13.9	33.35
K10R 132 M6 E	7.5	206.0	196.0	0.35	25.0	17.5	42.52
K10R 160 S6 E	11.0	255.0	162.5	0.40	33.0	26.2	59.20
K10R 160 M6 E	15.0	255.0	212.5	0.40	41.5	33.8	75.30
K10R 180 S6 E	18.5	288.0	206.5	0.45	49.0	38.1	87.10
K10R 180 M6 E	22	288.0	250.5	0.45	57.0	45.8	102.80
K10R 200 M6 E	30	322.0	252.5	0.45	80.0	58.6	138.60
K10R 225 M6 E	37	362.0	263.5	0.50	104.0	80.2	184.20
K10R 250 S6 E	45	410.0	255.0	0.55	133.0	99.5	232.50
K10R 250 M6 E	55	410.0	318.0	0.55	161.5	123.1	284.60
K10R 280 S6 E	75	465.0	306.0	0.70	220.0	159.0	379.00
K10R 280 M6 E	90	465.0	386.0	0.70	260.0	197.0	457.00
K10R 315 S6 E	110	465.0	416.0	0.70	270.0	213.0	483.00
K10R 315 M6 E	132	520.0	406.0	0.70	320.0	206.0	526.00
K10R 315 L6 E	160	520.0	456.0	0.70	380.0	350.0	730.00
K10R 315 LX6 E	200	520.0	586.0	0.70	460.0	-	460.00
K22R 355 MY6 E	200	610.0	442.0	0.90	600.0	-	600.00
K22R 355 M6 E	250	610.0	492.0	0.90	610.0	-	610.00
Synchronous speed 750 rpm – 8-pole version							
K20R 63 K8 E	0.09	96.0	62.0	0.20	2.06	1.05	3.11
K20R 63 G8 E	0.12	96.0	73.0	0.20	2.65	1.21	3.86
K20R 71 K8 E	0.18	110.0	66.0	0.20	2.73	1.70	4.43
K20R 71 G8 E	0.25	110.0	91.0	0.20	3.65	2.33	5.98
K20R 80 K8 E	0.37	126.0	80.0	0.25	4.05	2.83	6.88
K20R 80 G8 E	0.55	126.0	104.0	0.25	5.24	3.62	8.86
K20R 90 L8 E	0.75	140.0	110.0	0.25	6.56	4.73	11.29
K20R 100 S8 E	1.1	158.0	100.0	0.30	8.00	5.54	13.54
K20R 100 L8 E	1.5	158.0	139.0	0.30	10.75	7.63	18.38
K20R 112 M8 E	2.2	176.0	122.0	0.30	11.5	8.2	19.71
K20R 112 MX8 E	3.0	176.0	162.0	0.30	15.5	10.8	26.25
K10R 132 S8 E	4.0	206.0	153.0	0.35	19.5	13.9	33.35
K10R 132 M8 E	5.5	206.0	196.0	0.35	24.0	17.5	41.52
K10R 160 S8 E	7.5	255.0	162.5	0.40	31.0	26.2	57.20
K10R 160 M8 E	11.0	255.0	212.5	0.40	40.5	33.8	74.30
K10R 180 S8 E	15.0	288.0	206.5	0.45	48.0	38.1	86.10
K10R 180 M8 E	18.5	288.0	250.5	0.45	57.0	45.8	102.80
K10R 200 M8 E	22	322.0	252.5	0.45	77.0	58.6	135.60
K10R 225 M8 E	30	362.0	263.5	0.50	101.0	80.2	181.20
K10R 250 S8 E	37	410.0	255.0	0.55	129.0	99.5	228.50
K10R 250 M8 E	45	410.0	318.0	0.55	159.5	123.1	282.60
K10R 280 S8 E	55	465.0	306.0	0.70	220.0	159.0	379.00
K10R 280 M8 E	75	465.0	386.0	0.70	260.0	197.0	457.00
K10R 315 S8 E	90	465.0	416.0	0.70	270.0	213.0	483.00
K10R 315 M8 E	110	520.0	406.0	0.70	320.0	206.0	526.00
K10R 315 L8 E	132	520.0	456.0	0.70	380.0	350.0	730.00
K10R 315 LX8 E	160	520.0	486.0	0.70	460.0	-	460.00
K22R 355 MY8 E	160	610.0	442.0	0.80	510.0	-	510.00
K22R 355 M8 E	200	610.0	492.0	0.80	590.0	-	590.00

Dimensions

Three-phase built-in motors

Built-in motor without shaft
 Version for efficiency classes IE1, IE2 und IE3
 Principal dimensions for wound stator core

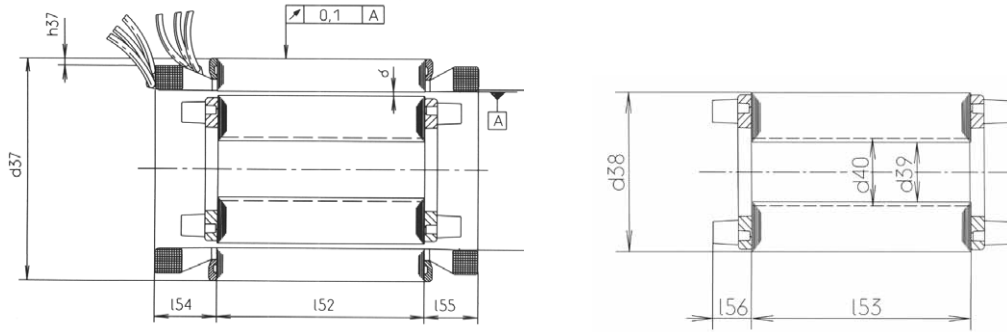

Built-in motors			d ₃₇	d _{gr} (Oversize)	d ₄₁	h ₃₇	l ₅₂	l ₅₄	l ₅₅	δ	d ₃₈ (Finished size)	d ₃₈ (Delivered size)	d ₃₈ (Delivered size)	d ₄₀ (Finished size max.)	l ₅₃	l ₅₆
for IE1	for IE2	for IE3	[mm]	[mm]	[mm]	[mm]	[mm]	[mm]	[mm]	[mm]	[mm]	[mm]	[mm]	[mm]	[mm]	[mm]
Synchronous speed 3000 rpm – 2-pole version																
K20R 56 K2 E			84	83.8	49.0	3.5	37.0	27.0	27.0	0.25	45.5	46.0	17.0	19.0	37.0	12.0
K20R 56 G2 E			84	83.8	49.0	3.5	47.0	27.0	27.0	0.25	45.5	46.0	17.0	19.0	47.0	12.0
K20R 63 K2 E			96	95.8	56.0	4.0	43.0	35.0	35.0	0.25	52.5	53.0	20.0	23.0	43.0	16.5
K20R 63 G2 E			96	95.8	56.0	4.0	59.0	31.0	31.0	0.25	52.5	53.0	20.0	23.0	59.0	16.5
K20R 71 K2 E			110	109.8	63.0	4.0	60.0	36.0	35.0	0.30	59.4	60.0	25.0	27.0	60.0	17.5
K20R 71 G2 E			110	109.8	63.0	4.0	81.0	36.0	35.0	0.30	59.4	60.0	25.0	27.0	81.0	17.5
K20R 80 K2 E			126	125.8	73.0	5.0	80.0	43.0	42.0	0.35	68.3	69.0	30.0	32.0	80.0	19.0
K20R 80 G2 E			126	125.8	73.0	5.0	108.0	43.0	42.0	0.35	68.3	69.0	30.0	32.0	108.0	19.0
K20R 90 L2 E			140	139.8	82.0	4.5	110.0	45.0	45.0	0.45	77.1	78.0	32.0	34.0	110.0	24.0
K20R 100 S2 E			158	157.8	92.0	4.5	112.0	56.0	53.0	0.55	86.9	88.0	35.0	37.0	112.0	33.5
K20R 100 L2 E			158	157.8	92.0	4.5	146.0	56.0	53.0	0.55	86.9	88.0	35.0	37.0	146.0	33.5
K10R 112 MY2 E			176	175.8	99.0	5.5	122.0	61.0	61.0	0.60	96.8	98.0	44.0	46.0	120.0	32.5
K10R 112 M2 E			176	175.8	99.0	5.5	162.0	61.0	61.0	0.60	96.8	98.0	44.0	46.0	160.0	32.5
	W10R 132 MY2 E	W40R 132 MY2 E	206	205.8	121.0	6.0	137.0	66.0	66.0	0.60	118.8	120.0	52.0	54.0	137.0	32.5
	K10R 132 M2 E		206	205.8	121.0	6.0	162.0	66.0	66.0	0.60	118.8	120.0	52.0	54.0	160.0	32.5
	K10R 160 S2 E	W10R 160 S2 E	255	254.8	148.0	6.5	153.5	76.0	76.0	0.70	145.6	147.0	55.0	58.0	151.0	35.0
	K10R 160 M2 E	W10R 160 M2 E	255	254.8	148.0	6.5	192.5	76.0	76.0	0.70	145.6	147.0	55.0	58.0	190.0	35.0
		W40R 160 MX2 E	255	254.8	148.0	6.5	220.0	76.0	76.0	0.70	145.6	147.0	55.0	58.0	220.0	35.0
	K10R 180 S2 E	W10R 180 S2 E	288	287.8	168.0	6.5	176.5	81.0	81.0	0.90	165.2	167.0	62.0	65.0	174.0	55.0
	K10R 180 M2 E	W10R 180 M2 E	288	287.8	168.0	6.5	226.5	81.0	81.0	0.90	165.2	167.0	62.0	65.0	224.0	55.0
		W10R 180 MX2 E	288	287.8	168.0	6.5	270.0	81.0	81.0	0.90	165.2	167.0	62.0	65.0	270.0	55.0
	K10R 200 M2 E	W40R 200 M2 E	322	321.8	187.0	9.0	212.5	99.0	99.0	1.00	184.0	186.0	75.0	78.0	210.0	55.0
	K10R 200 L2 E	W10R 200 L2 E	322	321.8	187.0	9.0	252.5	99.0	99.0	1.00	184.0	186.0	75.0	78.0	250.0	55.0
	K10R 225 M2 E	W10R 225 M2 E	362	361.8	211.0	11.0	250.5	115.0	115.0	1.20	207.6	210.0	85.0	88.0	247.0	57.5
	K10R 250 S2 E	W10R 250 S2 E	410	409.8	241.0	14.0	255.0	135.0	135.0	1.20	237.6	240.0	95.0	98.0	252.0	65.0
	K10R 250 M2 E	W10R 250 M2 E	410	409.8	241.0	14.0	283.0	135.0	135.0	1.20	237.6	240.0	95.0	98.0	280.0	65.0
	K10R 280 S2 E	W10R 280 S2 E	465	464.8	273.0	14.0	306.0	170.0	140.0	1.45	269.1	272.0	105.0	108.0	300.0	70.0
	K10R 280 M2 E	W10R 280 M2 E	465	464.8	273.0	14.0	361.0	170.0	140.0	1.45	269.1	272.0	105.0	108.0	355.0	70.0
	K10R 315 S2 E	W10R 315 S2 E	465	464.8	273.0	14.0	441.0	170.0	140.0	1.45	269.1	272.0	105.0	108.0	435.0	70.0
		W40R 315 S2 E	520	519.8	306.0	14.0	376.0	185.0	165.0	1.60	301.8	305.0	105.0	108.0	370.0	65.0
	K10R 315 M2 E	W10R 315 M2 E	520	519.8	306.0	14.0	446.0	185.0	165.0	1.60	301.8	305.0	130.0	133.0	440.0	80.0
	K10R 315 L2 E	W10R 315 L2 E	520	519.8	306.0	14.0	576.0	185.0	165.0	1.60	301.8	305.0	130.0	133.0	570.0	80.0
	K10R 315 LX2 E	W10R 315 LX2 E	520	519.8	306.0	14.0	696.0	185.0	165.0	1.60	301.8	305.0	130.0	133.0	690.0	80.0
		W22R 355 MY2 E	610	609.8	352.0	25.0	432.0	225.0	185.0	1.90	347.2	351.0	130.0	133.0	420.0	80.0
		W40R 355 M2 E	610	609.8	352.0	25.0	477.0	225.0	185.0	1.90	347.2	351.0	130.0	133.0	465.0	90.0
		W22R 355 MX2 E	610	609.8	352.0	25.0	591.0	225.0	185.0	1.90	347.2	351.0	130.0	133.0	580.0	80.0
		W42R 355 MX2 E	610	609.8	352.0	25.0	591.0	225.0	185.0	1.90	347.2	351.0	130.0	133.0	579.0	80.0
		W22R 355 L2 E	610	609.8	352.0	25.0	712.0	225.0	185.0	1.90	347.2	351.0	130.0	133.0	710.0	80.0
		W42R 355 L2 E	610	609.8	352.0	25.0	712.0	225.0	185.0	1.90	347.2	351.0	130.0	133.0	700.0	80.0
		W42R 400 M2 E	700	699.8	405.0	15.0	622.0	275.0	235.0	2.50	399.0	404.0	150.0	153.0	610.0	90.0
		W42R 400 MX2 E	700	699.8	405.0	15.0	692.0	275.0	235.0	2.50	399.0	404.0	150.0	153.0	680.0	90.0
		W42R 400 L2 E	700	699.8	405.0	15.0	742.0	275.0	235.0	2.50	399.0	404.0	150.0	153.0	730.0	90.0

Three-phase built-in motors

Built-in motor without shaft
Version for efficiency classes IE1, IE2 und IE3
Principal dimensions for wound stator core

Built-in motors			d_{37}	d_{37} (Oversize)	d_{41}	h_{37}	l_{52}	l_{54}	l_{55}	δ	d_{38} (Finished size)	d_{38} (Delivered size)	d_{39} (Delivered size)	d_{40} (Finished size, max.)	l_{53}	l_{56}
for IE1	for IE2	for IE3	[mm]	[mm]	[mm]	[mm]	[mm]	[mm]	[mm]	[mm]	[mm]	[mm]	[mm]	[mm]	[mm]	[mm]
Synchronous speed 1500 rpm – 4-pole version																
K20R 56 K4 E			84	83.8	54.0	3.5	37.0	27.0	27.0	0.20	50.6	51.0	17.0	20.0	37.0	10.0
K20R 56 G4 E			84	83.8	54.0	3.5	49.0	27.0	27.0	0.20	50.6	51.0	17.0	20.0	49.0	10.0
K20R 63 K4 E			96	95.8	62.0	4.0	45.0	31.0	29.0	0.20	58.6	59.0	20.0	23.0	45.0	15.0
K20R 63 G4 E			96	95.8	62.0	4.0	62.0	31.0	29.0	0.20	58.6	59.0	20.0	23.0	62.0	15.0
K20R 71K4 E			110	109.8	70.0	4.0	63.0	35.0	33.0	0.20	66.6	67.0	25.0	27.0	63.0	17.5
K20R 71G4 E			110	109.8	70.0	4.0	81.0	35.0	33.0	0.20	66.6	67.0	25.0	27.0	81.0	17.5
K20R 80 K4 E			126	125.8	82.0	5.0	80.0	39.0	38.0	0.25	77.5	78.0	30.0	34.0	80.0	14.5
K20R 80 G4 E			126	125.8	82.0	5.0	104.0	39.0	38.0	0.25	77.5	78.0	30.0	34.0	104.0	14.5
K20R 90 L4 E			140	139.8	90.0	4.5	110.0	43.0	42.0	0.30	85.4	86.0	32.0	36.0	110.0	24.0
K20R 100 S4 E			158	157.8	103.0	4.5	112.0	49.0	48.0	0.35	98.3	99.0	35.0	39.0	112.0	33.5
K20R 100 L4 E			158	157.8	103.0	4.5	146.0	49.0	48.0	0.35	98.3	99.0	35.0	39.0	146.0	33.5
K20R 100 LX4 E			158	157.8	103.0	4.5	180.0	49.0	48.0	0.35	98.3	99.0	35.0	39.0	180.0	33.5
K10R 112 M4 E			176	175.8	111.0	5.5	142.0	64.0	56.0	0.35	109.3	110.0	44.0	46.0	142.0	32.5
K10R 132 S4 E		W40R 132 S4 E	206	205.8	129.0	6.0	139.0	71.0	61.0	0.45	127.1	128.0	52.0	54.0	137.0	32.5
K10R 132 M4 E	W10R 132 M4 E	W40R 132 M4 E	206	205.8	129.0	6.0	196.0	71.0	61.0	0.45	127.1	128.0	52.0	54.0	194.0	32.5
	W10R 132 MX4 E	W40R 132 MX4 E	206	205.8	129.0	6.0	240.0	71.0	61.0	0.45	127.1	128.0	52.0	54.0	240.0	32.5
K10R 160 S4 E	W10R 160 S4 E	W40R 160 S4 E	255	254.8	159.0	6.5	165.0	83.0	71.0	0.45	157.2	158.0	62.0	66.0	165.0	35.0
K10R 160 M4 E			255	254.8	159.0	6.5	195.0	83.0	71.0	0.45	157.2	158.0	62.0	66.0	195.0	35.0
	W10R 160 L4 E	W40R 160 L4 E	255	254.8	159.0	6.5	250.0	83.0	71.0	0.45	157.2	158.0	62.0	66.0	250.0	35.0
K10R 180 S4 E	W10R 180 S4 E		288	287.8	179.0	6.5	191.0	88.0	76.0	0.55	176.9	178.0	72.0	76.0	191.0	43.5
K10R 180 M4 E	W10R 180 M4 E	W40R 180 M4 E	288	287.8	179.0	6.5	248.0	88.0	76.0	0.55	176.9	178.0	72.0	76.0	248.0	43.5
		W40R 180 MX4 E	288	287.8	179.0	6.5	300.0	88.0	76.0	0.55	176.9	178.0	72.0	76.0	300.0	43.5
K10R 200 M4 E	W10R 200 M4 E		322	321.8	201.0	9.0	250.0	99.0	91.0	0.65	198.7	20.0	85.0	90.0	250.0	45.0
K10R 200 L4 E	W10R 200 L4 E	W40R 200 L4 E	322	321.8	201.0	9.0	290.0	99.0	91.0	0.65	198.7	200.0	85.0	90.0	290.0	45.0
	W10R 200 LX4 E	W40R 200 LX4 E	322	321.8	201.0	9.0	330.0	99.0	91.0	0.65	198.7	200.0	85.0	90.0	330.0	45.0
K10R 225 M4 E	W10R 225 M4 E		362	361.8	227.0	11.0	280.0	112.0	97.0	0.70	224.6	226.0	95.0	110.0	280.0	49.0
	W10R 225 MX4 E	W40R 225 MX4 E	362	361.8	227.0	11.0	340.0	112.0	97.0	0.70	224.6	226.0	95.0	110.0	340.0	49.0
K10R 250 S4 E	W10R 250 S4 E	W40R 250 S4 E	410	409.8	259.0	14.0	310.0	125.0	105.0	0.80	256.4	258.0	105.0	110.0	310.0	50.0
K10R 250 M4 E	W10R 250 M4 E	W40R 250 M4 E	410	409.8	259.0	14.0	364.0	125.0	105.0	0.80	256.4	258.0	105.0	110.0	364.0	50.0
K10R 280 S4 E	W10R 280 S4 E	W40R 280 S4 E	465	464.8	296.0	14.0	351.0	145.0	120.0	1.00	293.0	295.0	115.0	120.0	345.0	65.0
K10R 280 M4 E	W10R 280 M4 E	W40R 280 M4 E	465	464.8	296.0	14.0	406.0	145.0	120.0	1.00	293.0	295.0	115.0	120.0	400.0	65.0
K10R 315 S4 E	W10R 315 S4 E		465	464.8	296.0	14.0	486.0	145.0	120.0	1.10	292.8	295.0	115.0	120.0	480.0	65.0
		W40R 315 S4 E	520	519.8	341.0	14.0	406.0	155.0	125.0	1.00	338.0	340.0	130.0	135.0	400.0	65.0
K10R 315 M4 E	W10R 315 M4 E	W40R 315 M4 E	520	519.8	341.0	14.0	486.0	155.0	125.0	1.00	338.0	340.0	130.0	135.0	480.0	75.0
K10R 315 L4 E	W10R 315 L4 E	W40R 315 L4 E	520	519.8	341.0	14.0	606.0	155.0	125.0	1.00	338.0	340.0	130.0	135.0	600.0	75.0
K10R 315 LX4 E	W10R 315 LX4 E	W40R 315 LX4 E	520	519.8	341.0	14.0	696.0	155.0	125.0	1.00	338.0	340.0	130.0	135.0	690.0	75.0
K22R 355 MY4 E	W22R 355 MY4 E	W40R 355 MY4 E	610	609.8	376.0	25.0	492.0	215.0	175.0	1.50	372.0	375.0	150.0	155.0	480.0	75.0
K22R 355 M4 E	W22R 355 M4 E	W40R 355 M4 E	610	609.8	376.0	25.0	492.0	215.0	175.0	1.50	372.0	375.0	150.0	155.0	590.0	89.0
	W22R 355 MX4 E		610	609.8	376.0	25.0	712.0	215.0	175.0	1.50	372.0	375.0	150.0	155.0	700.0	89.0
		W42R 355 MX4 E	610	609.8	376.0	25.0	712.0	215.0	175.0	1.50	372.0	375.0	150.0	155.0	700.0	82.0
	W22R 355 L4 E		610	609.8	376.0	25.0	752.0	215.0	175.0	1.50	372.0	375.0	150.0	155.0	740.0	89.0
		W42R 355 L E	610	609.8	376.0	25.0	752.0	215.0	175.0	1.50	372.0	375.0	150.0	155.0	740.0	82.0
		W42R 400 M4 E	700	699.8	441.0	15.0	292.0	255.0	215.0	1.60	436.8	440.0	155.0	160.0	580.0	80.0
		W42R 400 MX4 E	700	699.8	441.0	15.0	662.0	255.0	215.0	1.60	436.8	440.0	155.0	160.0	650.0	80.0
		W42R 400 L4 E	700	699.8	441.0	15.0	747.0	255.0	215.0	1.60	436.8	440.0	155.0	160.0	735.0	80.0

Three-phase built-in motors with squirrel-cage rotor

Built-in motor without shaft
Version for efficiency classes IE1, IE2 und IE3
Principal dimensions for wound stator core

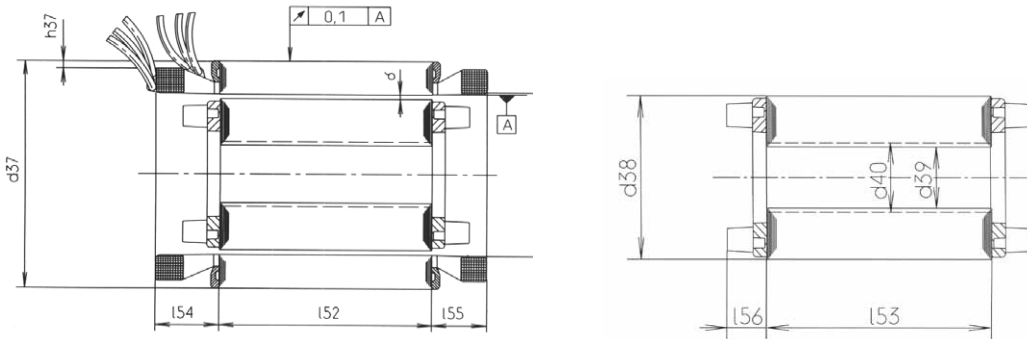

Built-in motors			d ₃₇	d ₃₇ (Oversize)	d ₄₁	h ₃₇	l ₅₂	l ₅₄	l ₅₅	δ	d ₃₈ (Finished size)	d ₃₈ (Delivered size)	d ₃₉ (Delivered size)	d ₄₀ (Finished size, max.)	l ₅₃	l ₅₆
for IE1	for IE2	for IE3	[mm]	[mm]	[mm]	[mm]	[mm]	[mm]	[mm]	[mm]	[mm]	[mm]	[mm]	[mm]	[mm]	[mm]
Synchronous speed 1000 rpm – 6-pole version																
K20R 56 K6 E			84	83.8	54.0	3.5	49.0	25.0	25.0	0.20	50.66	51.0	17.0	20.0	49.0	10.0
K20R 56 G6 E			84	83.8	54.0	3.5	62.0	25.0	25.0	0.20	50.66	51.0	17.0	20.0	62.0	10.0
K20R 63 K6 E			96	95.8	62.0	4.0	62.0	24.0	24.0	0.20	58.66	59.0	20.0	24.0	62.0	8.5
K20R 63 G6 E			96	95.8	62.0	4.0	76.0	25.0	25.0	0.20	58.66	59.0	20.0	24.0	76.0	8.5
K20R 71 K6 E			110	109.8	76.0	4.0	66.0	30.0	30.0	0.20	72.6	73.0	25.0	30.0	66.0	12.5
K20R 71 G6 E			110	109.8	76.0	4.0	91.0	30.0	30.0	0.20	72.6	73.0	25.0	30.0	91.0	12.5
K20R 80 K6 E			126	125.8	88.0	5.0	89.0	36.0	35.0	0.25	85.5	86.0	30.0	36.0	89.0	13.0
K20R 80 G6 E			126	125.8	88.0	5.0	120.0	36.0	35.0	0.25	85.5	86.0	30.0	36.0	120.0	13.0
K20R 90 L6 E			140	139.8	98.0	4.5	120.0	35.0	35.0	0.25	94.5	95.0	32.0	40.0	120.0	19.0
K20R 100 L6 E			158	157.8	112.0	4.5	139.0	41.0	40.0	0.30	106.4	107.0	35.0	43.0	139.0	20.0
K10R 112 M6 E			176	175.8	121.0	5.5	122.0	59.0	51.0	0.30	119.4	120.0	44.0	52.0	120.0	32.5
K10R 112 MX6 E			176	175.8	121.0	5.5	162.0	59.0	51.0	0.30	119.4	120.0	44.0	52.0	160.0	32.5
K10R 132 S6 E	W10R 132 S6 E	W40R 132 S6 E	206	205.8	143.0	6.0	153.0	66.0	56.0	0.35	141.3	142.0	52.0	60.0	151.0	32.5
K10R 132 M6 E	W10R 132 M6 E		206	205.8	143.0	6.0	196.0	66.0	56.0	0.35	141.3	142.0	52.0	60.0	194.0	32.5
	W10R 132 MX6 E	W40R 132 MX6 E	206	205.8	143.0	6.0	240.0	66.0	56.0	0.35	141.3	142.0	52.0	60.0	240.0	32.5
K10R 160 S6 E			255	254.8	177.0	6.5	162.5	78.0	66.0	0.40	175.2	176.0	62.0	68.0	160.0	35.0
K10R 160 M6 E	W10R 160 M6 E	W40R 160 M6 E	255	254.8	177.0	6.5	212.5	78.0	66.0	0.40	175.2	176.0	62.0	68.0	210.0	35.0
	W10R 160 L6 E	W40R 160 L6 E	255	254.8	177.0	6.5	240.0	78.0	66.0	0.40	175.2	176.0	62.0	68.0	240.0	35.0
K10R 180 S6 E			288	287.8	201.0	6.5	206.5	83.0	71.0	0.45	199.1	200.0	72.0	80.0	204.0	43.5
K10R 180 M6 E	W10R 180 M6 E	W40R 180 M6 E	288	287.8	201.0	6.5	250.5	83.0	71.0	0.45	199.1	200.0	72.0	80.0	248.0	43.5
K10R 180 MX6 E	W10R 180 MX6 E		288	287.8	201.0	6.5	294.0	83.0	71.0	0.45	199.1	200.0	72.0	80.0	294.0	43.5
K10R 200 M6 E	W10R 200 M6 E		322	321.8	225.0	9.0	252.5	96.0	81.0	0.45	223.1	224.0	85.0	95.0	250.0	45.0
	W10R 200 L6 E	W40R 200 L6 E	322	321.8	225.0	9.0	290.0	96.0	81.0	0.45	223.1	224.0	85.0	95.0	290.0	45.0
K10R 225 M6 E	W10R 225 M6 E		362	361.8	253.0	11.0	263.5	107.0	92.0	0.50	251.0	252.0	95.0	105.0	260.0	49.0
	W10R 225 MX6 E	W40R 225 MX6 E	362	361.8	253.0	11.0	290.0	107.0	92.0	0.50	251.0	252.0	95.0	105.0	290.0	49.0
K10R 250 S6 E	W10R 250 S6 E	W40R 250 S6 E	410	409.8	289.0	14.0	255.0	115.0	95.0	0.55	286.9	288.0	105.0	110.0	252.0	50.0
K10R 250 M6 E	W10R 250 M6 E	W40R 250 M6 E	410	409.8	289.0	14.0	318.0	115.0	95.0	0.55	286.9	288.0	105.0	110.0	315.0	50.0
K10R 280 S6 E	W10R 280 S6 E	W40R 280 S6 E	465	464.8	329.0	14.0	306.0	145.0	120.0	0.70	326.6	328.0	115.0	120.0	300.0	65.0
K10R 280 M6 E	W10R 280 M6 E	W40R 280 M6 E	465	464.8	329.0	14.0	386.0	145.0	120.0	0.70	326.6	328.0	115.0	120.0	380.0	65.0
K10R 315 S6 E	W10R 315 S6 E		465	464.8	329.0	14.0	416.0	135.0	115.0	0.70	326.6	328.0	115.0	120.0	410.0	65.0
		W40R 315 S6 E	520	519.8	376.0	14.0	376.0	145.0	125.0	0.70	373.6	375.0	130.0	135.0	370.0	50.0
K10R 315 M6 E	W10R 315 M6 E	W40R 315 M6 E	520	519.8	376.0	14.0	406.0	145.0	125.0	0.70	373.6	375.0	130.0	135.0	400.0	65.0
K10R 315 L6 E	W10R 315 L6 E	W40R 315 L6 E	520	519.8	376.0	14.0	456.0	145.0	125.0	0.70	373.6	375.0	130.0	135.0	450.0	65.0
K10R 315 LX6 E	W10R 315 LX6 E	W40R 315 LX6 E	520	519.8	376.0	14.0	586.0	145.0	125.0	0.70	373.6	375.0	130.0	135.0	580.0	65.0
K22R 355 MY6 E	W22R 355 MY6 E	W40R 355 MY6 E	610	609.8	409.0	25.0	442.0	175.0	145.0	0.90	406.2	408.0	150.0	155.0	430.0	78.0
K22R 355 M6 E	W22R 355 M6 E	W40R 355 M6 E	610	609.8	409.0	25.0	492.0	175.0	145.0	0.90	406.2	408.0	150.0	155.0	480.0	68.0
	W22R 355 MX6 E		610	609.8	409.0	25.0	697.0	175.0	145.0	0.90	406.2	408.0	150.0	155.0	685.0	78.0
		W42R 355 MX6 E	610	609.8	409.0	25.0	697.0	175.0	145.0	0.90	406.2	408.0	150.0	155.0	685.0	85.0
		W42R 355 LY6 E	610	609.8	409.0	25.0	732.0	175.0	145.0	0.90	406.2	408.0	150.0	155.0	720.0	85.0
	W22R 355 L6 E		610	609.8	409.0	25.0	732.0	175.0	145.0	0.90	406.2	408.0	150.0	155.0	730.0	78.0
		W42R 355 L6 E	610	609.8	409.0	25.0	732.0	175.0	145.0	0.90	406.2	408.0	150.0	155.0	720.0	85.0
		W42R 355 LX6 E	610	609.8	409.0	25.0	732.0	175.0	145.0	0.90	406.2	408.0	150.0	155.0	720.0	85.0
		W42R 355 LZ6 E	610	609.8	409.0	25.0	732.0	175.0	145.0	0.90	406.2	408.0	150.0	155.0	720.0	85.0
		W42R 400 M6 E	700	699.8	473.0	15.0	607.0	225.0	175.0	1.30	469.4	472.0	170.0	175.0	595.0	75.0
		W42R 400 MX6 E	700	699.8	473.0	15.0	692.0	225.0	175.0	1.30	469.4	472.0	170.0	175.0	680.0	75.0
		W42R 400 L6 E	700	699.8	473.0	15.0	752.0	225.0	175.0	1.30	469.4	472.0	170.0	175.0	740.0	75.0

Three-phase built-in motors with squirrel-cage rotor

Built-in motor without shaft
Version for efficiency classes IE1, IE2 und IE3
Principal dimensions for wound stator core

Built-in motors			d_{37}	d_{37} (Oversize)	d_{41}	h_{37}	l_{52}	l_{54}	l_{55}	δ	d_{38} (Finished size)	d_{38} (Delivered size)	d_{39} (Delivered size)	d_{40} (Finished size, max.)	l_{53}	l_{56}
for IE1	for IE2	for IE3	[mm]	[mm]	[mm]	[mm]	[mm]	[mm]	[mm]	[mm]	[mm]	[mm]	[mm]	[mm]	[mm]	[mm]
Synchronous speed 750 rpm – 8-pole version																
K20R 63 K8 E			96	95.8	62.0	4.0	62.0	24.0	24.0	0.20	58.6	59.0	20.0	24.0	62.0	8.5
K20R 63 G8 E			96	95.8	62.0	4.0	73.0	24.0	24.0	0.20	58.6	59.0	20.0	24.0	73.0	8.5
K20R 71 K8 E			110	109.8	76.0	4.0	66.0	30.0	30.0	0.20	72.6	73.0	25.0	30.0	66.0	12.5
K20R 71 G8 E			110	109.8	76.0	4.0	91.0	30.0	30.0	0.20	72.6	73.0	25.0	30.0	91.0	12.5
K20R 80 K8 E			126	125.8	88.0	5.0	80.0	36.0	35.0	0.25	85.5	86.0	30.0	36.0	80.0	13.0
K20R 80 G8 E			126	125.8	88.0	5.0	104.0	36.0	35.0	0.25	85.5	86.0	30.0	36.0	104.0	13.0
K20R 90 L8 E			140	139.8	98.0	4.5	110.0	35.0	35.0	0.25	94.5	95.0	32.0	40.0	110.0	24.0
K20R 100 S8 E			158	157.8	112.0	4.5	100.0	40.0	40.0	0.25	106.4	107.0	35.0	43.0	100.0	20.0
K20R 100 L8 E			158	157.8	112.0	4.5	139.0	40.0	40.0	0.30	106.4	107.0	35.0	43.0	139.0	20.0
K10R 112 M8 E			176	175.8	121.0	5.5	122.0	59.0	51.0	0.30	119.4	120.0	44.0	52.0	120.0	32.5
K10R 112 MX8 E			176	175.8	121.0	5.5	162.0	59.0	51.0	0.30	119.4	120.0	44.0	52.0	160.0	32.5
K10R 132 S8 E	W10R 132 S8 E	W40R 132 S8 E	206	205.8	143.0	6.0	153.0	66.0	56.0	0.35	141.3	142.0	52.0	60.0	151.0	32.5
K10R 132 M8 E	W10R 132 M8 E		206	205.8	143.0	6.0	196.0	66.0	56.0	0.35	141.3	142.0	52.0	60.0	194.0	32.5
	W10R 132 MX8 E	W40R 132 MX8 E	206	205.8	143.0	6.0	240.0	66.0	56.0	0.35	141.3	142.0	52.0	60.0	240.0	32.5
K10R 160 S8 E	W10R 160 S8 E	W40R 160 S8 E	255	254.8	177.0	6.5	162.5	78.0	66.0	0.40	175.2	176.0	62.0	68.0	160.0	35.0
K10R 160 M8 E	W10R 160 M8 E	W40R 160 M8 E	255	254.8	177.0	6.5	212.5	78.0	66.0	0.40	175.2	176.0	62.0	68.0	210.0	35.0
	W10R 160 L8 E	W40R 160 L8 E	255	254.8	177.0	6.5	240.0	78.0	66.0	0.40	175.2	176.0	62.0	68.0	240.0	35.0
K10R 180 S8 E	W10R 180 S8 E	W40R 180 S8 E	288	287.8	201.0	6.5	206.5	83.0	71.0	0.45	199.1	200.0	72.0	80.0	204.0	43.5
K10R 180 M8 E	W10R 180 M8 E		288	287.8	201.0	6.5	250.5	83.0	71.0	0.45	199.1	200.0	72.0	80.0	248.0	43.5
		W40R 180 MX8 E	288	287.8	201.0	6.5	294.0	83.0	71.0	0.45	199.1	200.0	72.0	80.0	294.0	43.5
K10R 200 M8 E	W10R 200 M8 E		322	321.8	225.0	9.0	252.5	96.0	81.0	0.45	223.1	224.0	85.0	95.0	250.0	45.0
	W10R 200 L8 E	W40R 200 L8 E	322	321.8	225.0	9.0	290.0	96.0	81.0	0.45	223.1	224.0	85.0	95.0	290.0	45.0
K10R 225 M8 E	W10R 225 M8 E	W40R 225 M8 E	362	361.8	253.0	11.0	263.5	107.0	92.0	0.50	251.0	252.0	95.0	105.0	260.0	49.0
	W10R 225 MX8 E	W40R 225 MX8 E	362	361.8	253.0	11.0	290.0	107.0	92.0	0.50	251.0	252.0	95.0	105.0	290.0	49.0
K10R 250 S8 E	W10R 250 S8 E	W40R 250 S8 E	410	409.8	289.0	14.0	255.0	110.0	90.0	0.55	286.9	288.0	105.0	110.0	252.0	50.0
K10R 250 M8 E	W10R 250 M8 E	W40R 250 M8 E	410	409.8	289.0	14.0	318.0	110.0	90.0	0.55	286.9	288.0	105.0	110.0	315.0	50.0
K10R 280 S8 E	W10R 280 S8 E	W40R 280 S8 E	465	464.8	329.0	14.0	306.0	140.0	115.0	0.70	326.6	328.0	115.0	120.0	300.0	65.0
K10R 280 M8 E	W10R 280 M8 E	W40R 280 M8 E	465	464.8	329.0	14.0	386.0	140.0	115.0	0.70	326.6	328.0	115.0	120.0	380.0	65.0
K10R 315 S8 E	W10R 315 S8 E		465	464.8	329.0	14.0	416.0	135.0	115.0	0.70	326.6	328.0	115.0	120.0	410.0	65.0
		W40R 315 S8 E	465	464.8	329.0	14.0	376.0	145.0	125.0	0.70	373.6	375.0	130.0	135.0	370.0	50.0
K10R 315 M8 E	W10R 315 M8 E	W40R 315 M8 E	520	519.8	376.0	14.0	406.0	145.0	125.0	0.70	373.6	375.0	130.0	135.0	400.0	65.0
K10R 315 L8 E	W10R 315 L8 E	W40R 315 L8 E	520	519.8	376.0	14.0	456.0	145.0	125.0	0.70	373.6	375.0	130.0	135.0	450.0	65.0
K10R 315 LX8 E	W10R 315 LX8 E	W40R 315 LX8 E	520	519.8	376.0	14.0	486.0	145.0	125.0	0.70	373.6	375.0	130.0	135.0	480.0	65.0
K22R 355 MY8 E	W22R 355 MY8 E	W40R 355 MY8 E	610	609.8	421.0	24.0	442.0	175.0	140.0	0.80	418.4	420.0	150.0	155.0	430.0	90.0
K22R 355 M8 E	W22R 355 M8 E	W40R 355 M8 E	610	609.8	421.0	24.0	492.0	175.0	140.0	0.80	418.4	420.0	150.0	155.0	480.0	90.0
	W22R 355 MX8 E		610	609.8	421.0	25.0	492.0	175.0	140.0	0.8	418.4	420.0	150.0	155.0	660.0	90.0
		W42R 355 MX8 E	610	609.8	421.0	25.0	492.0	175.0	140.0	0.8	418.4	420.0	150.0	155.0	660.0	85.0
	W22R 355 L8 E		610	609.8	421.0	25.0	492.0	175.0	140.0	0.8	418.4	420.0	150.0	155.0	730.0	90.0
		W42R 355 L8 E	610	609.8	421.0	25.0	492.0	175.0	140.0	0.8	418.4	420.0	150.0	155.0	720.0	85.0
		W42R 400 M8 E	700	699.8	473.0	25.0	607.0	225.0	175.0	1	470.0	472.0	170.0	175.0	595.0	75.0
		W42R 400 MX8 E	700	699.8	473.0	25.0	692.0	225.0	175.0	1	470.0	472.0	170.0	175.0	680.0	75.0
		W42R 400 L8 E	700	699.8	473.0	25.0	752.0	225.0	175.0	1	470.0	472.0	170.0	175.0	740.0	75.0



VEM  MOTOR

Fire-gas motors

Contents

Product description	8/2
Overview of technical data	8/6
Motor selection data	
Performance data for IE3 version	8/7
Performance data for IE2 version	8/9
Performance data for IE1 version	8/11
Bearings	8/15
Terminal boxes	
Identical to terminal boxes of standard motors, see Chapter 2	
Dimensions	8/23

Product description

Three-phase asynchronous motors for use in powered smoke and heat extraction systems Fire-gas versions F₂₀₀ – F₄₀₀ (F₆₀₀) to EN 12101-3

Taking up the basic design features of the VEM asynchronous motor series, specifically modified insulation systems, bearings and cable connections were developed to enable use in powered smoke and heat extraction systems.

These fire-gas motors operate as conventional fan motors under normal circumstances, but are designed such that, in case of a fire, they continue to function under the significantly increased temperatures for a specified period of time before they are permitted to fail. Already at the design stage, strict testing is implemented to simulate corresponding emergency situations as realistically as possible.



As the real operating conditions are always dependent on the individual application, further tests on the final product must be performed by the fan manufacturer. The smallest and largest models of each series are tested. For these tests, the motors are fitted with additional thermosensors to enable exact monitoring of the temperatures inside the motor. Such sensors are normally incorporated at the bearings, in the winding overhang and in the core slot.



Practical use is only permitted after successful completion of the testing.



VEM fire-gas motors are already in proven use in numerous major tunnels, including for example the Öresund tunnel, and are there operating under the most varied conditions (road and rail tunnels, see photos).



Numerous different design variants are used. For jet fans, the dominant construction Type is "pad-mounted". Where higher outputs are required, the cables can also be routed out via the bearing end shield at the N-end.

Classification according to DIN EN 12101-3

In accordance with DIN EN 12101-3, fire-gas motors are assigned to classes from F₂₀₀ to F₆₀₀.

Fire-gas temperature	Duration of thermal stress		Classification acc. to EN 12101-3
	1 h	2 h	
200 °C		•	F ₂₀₀
300 °C	•		F ₃₀₀
400 °C		•	F ₄₀₀
600 °C	•		F ₆₀₀ ^{*)}

^{*)} upon request

In practice, however, operators often demand stress exposure durations which deviate from those specified in the DIN EN standard; such cases are assigned to the appropriate basic class.

In class F₂₀₀, the assignments between mounting dimensions and rated output correspond to DIN 42673/DIN 42677. The rated outputs are reduced in classes F₃₀₀ and F₄₀₀. Detailed information can be found in the tables of technical data. Pole-changing motors with two speeds can

be supplied upon request. The data given in the technical selection lists refer to self-ventilated motors with Type of cooling IC 411. Where motors without self-ventilation are incorporated into jet fans or ventilation ducts (Type of cooling IC 418), motor cooling is provided by the fan of the overall system with its significantly greater cooling air flow. This permits raising of the output power. Motors are then configured on a customer-specific basis.

Insulation systems

In case of a fire, the insulation systems of fire-gas motors are subjected to extreme temperatures, which may even lead to disintegration and destruction of the insulation

materials. The insulation thus consists of materials of thermal class F, H or 250/IEC 60085, depending on the specified stress temperatures.

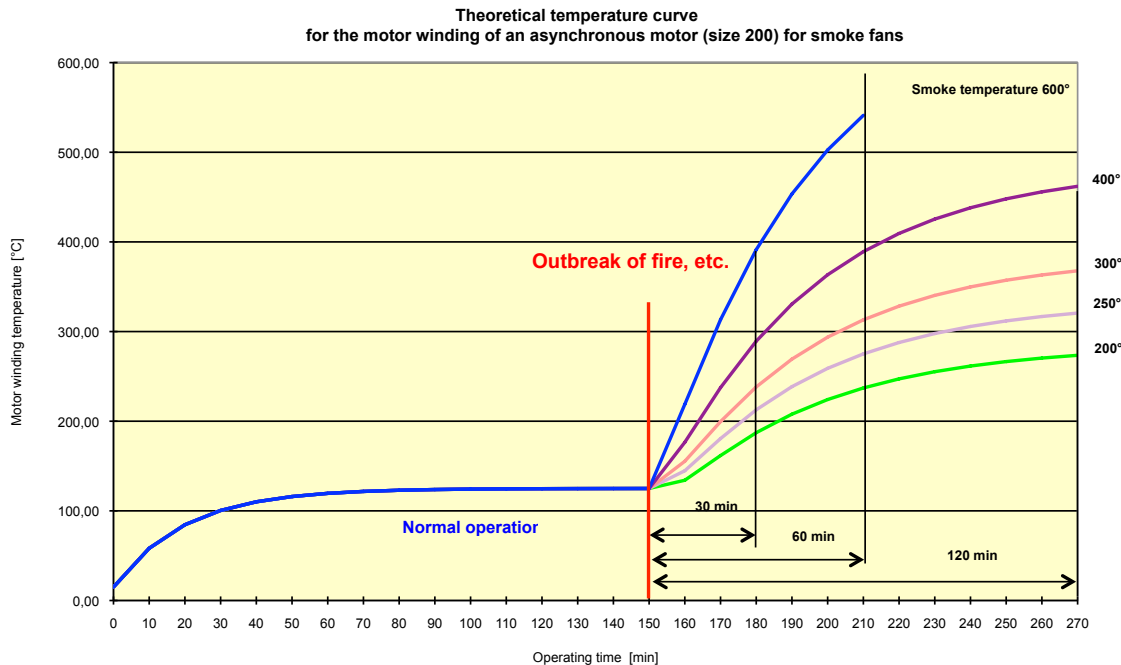

Temperature curve for the motor winding of an asynchronous motor (size 200)

Materials

Shaft height	Housing	Material for End shields	Feet	Foot mounting
132 to 280		Grey cast iron		Bolted
315, 355, 400				Cast-on

Types of construction and dimensions

Motors can be supplied in all Types of construction of the VEM basic series. The mounting dimensions are similarly

identical to the corresponding basic versions. A design version "pad-mounted" can be supplied upon request.

Notes regarding mode of operation

The motors are intended for use in powered smoke and heat extraction systems in accordance with EN 12101-3. They are dual-function motors for normal and emergency operation.

Normal operation:

Operation under normal conditions in accordance with the rating plate specifications.

Duty Type: S1

Ambient temperature: -20 °C to +40 °C

Installation altitude: ≤ 1000 m

Any deviating specifications on the rating plate must always be observed. The conditions at the place of installation must correspond to the rating plate specifications.

Emergency operation:

Short-time duty S2, running time dependent on the fire-gas class. Emergency operation is understood to mean operation under conditions which deviate from those of normal operation. This refers, in particular, to the occurrence of an emergency situation as defined according to EN 12101-3 (temperature-time classification). If an emergency situation occurs, the thermal winding protection must be disabled immediately!

After the occurrence of any emergency situation, the affected motors must always be replaced!

If the operating conditions deviate from the normal conditions specified on the rating plate without this constituting an emergency situation, a reduced service lifetime and reduced suitability to withstand an emergency situation must be expected. The motors are designed for use in industrial environments. Use in areas subject to an explosion hazard is forbidden.

Special designations for fire-gas versions

Special designation	Emergency operation	Class acc. to EN 12101	Remarks
FV (old FV0)	1 h at 200 °C	F _{f200} (60)	
FV1	2 h at 200 °C	F ₂₀₀	
	1 h at 250 °C	F _{f250} (60)	
FV2	1 h at 300 °C	F ₃₀₀	Discontinuation due to new development*
FV2-1	1 h at 300 °C		New development, replacing FV2
FV2	2 h at 250 °C	F _{f250}	Discontinuation due to new development*
FV2-1	2 h at 250 °C		New development, replacing FV2
FV3	2 h at 300 °C	F _{f300}	Discontinuation due to new development*
FV3-1	2 h at 300 °C		New development, replacing FV3
FV4-2	1 h at 400 °C	F _{f400} (60)	Discontinuation due to new development*
	1.5 h at 400 °C	F _{f400} (90)	
	2 h at 400 °C		
FV4-3	2 h at 400 °C	F ₄₀₀	Customer-specific special version
FV4-4	2 h at 400 °C		New development, replacing für FV4-2
FV5X	1 h at 600 °C	F ₆₀₀ X	Motor with thermal protection
FV5	1 h at 600 °C	F ₆₀₀	

* Consultation with the manufacturer necessary

Newly developed versions FV2-1, FV3-1 and FV4-4 are available for the Types FV2, FV3 and FV4-2. These new versions are to be preferred when developing new fan systems, as supplies of the individual materials used in the original versions will be significantly limited in the future. When switching, however, it must be taken into account that renewed approval testing for the fan system may be necessary.

Motors for efficiency classes IE2 and IE3 in sizes 132...400 can only be supplied on the basis of the newly developed systems FV2-1, FV3-1 and FV4-4. Motors are supplied on the basis of a manufacturer's declaration until the results of customer testing of the overall system become available.

Motor connection

Upon customer request, it is possible – to a limited extent – to use terminal boxes with a connection plate. In such cases, the following conditions apply: VEM standard connection plates may be used for classes $F_{200}(60)$, F_{200} , $F_{250}(60)$ and $F_{600}X$. Ceramic connection plates with a stud diameter up to M6 are available for F_{300} , F_{250} and F_{300} (corresponding to terminal box 63 A). From fire-gas class F_{400} , the connection is realised exclusively by way of high-temperature-resistant cables or specially insulated single conductors, which can also be provided with protective tubing.

Where motors are designed with a terminal box, the connection cables used must be appropriate for the specified fire-gas class. Cable lugs must only be crimped; solder connections are not permitted. For further details of terminal boxes, please refer to the section “Terminal boxes” in Chapter 2 “Standard motors”. The assignments of terminal boxes can be taken from the dimension drawings.

Motor version with connected cables

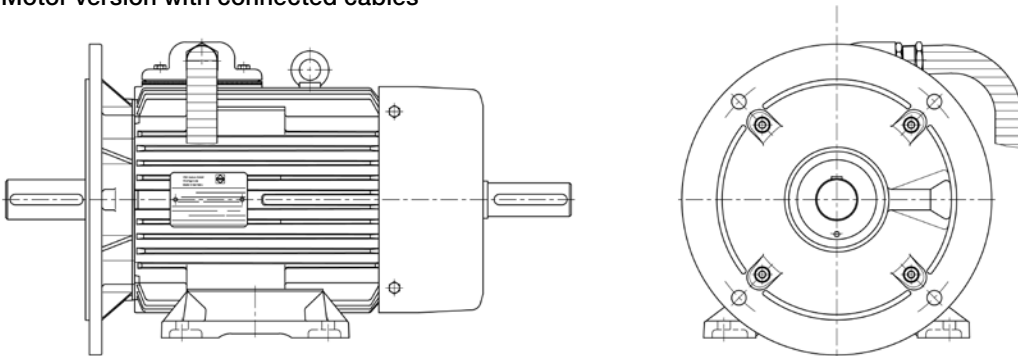

Connection cable with protective tubing, connection plate at top

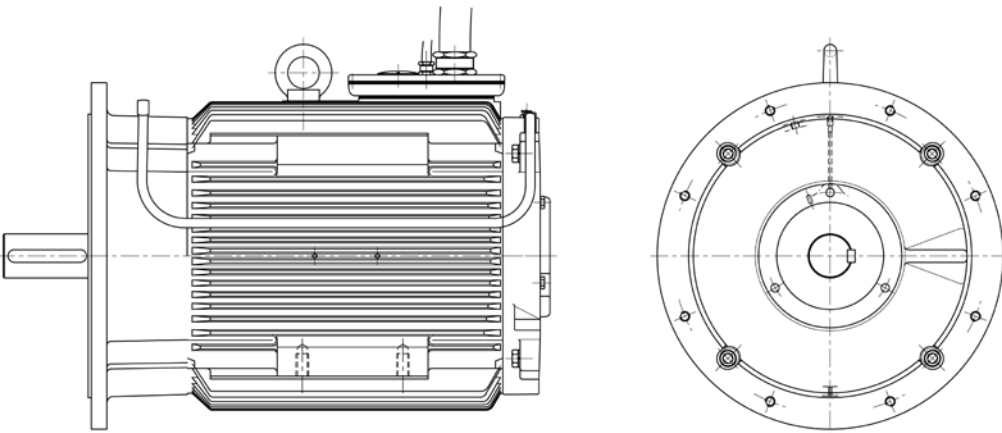

Connection cable without protective tubing, connection plate at top

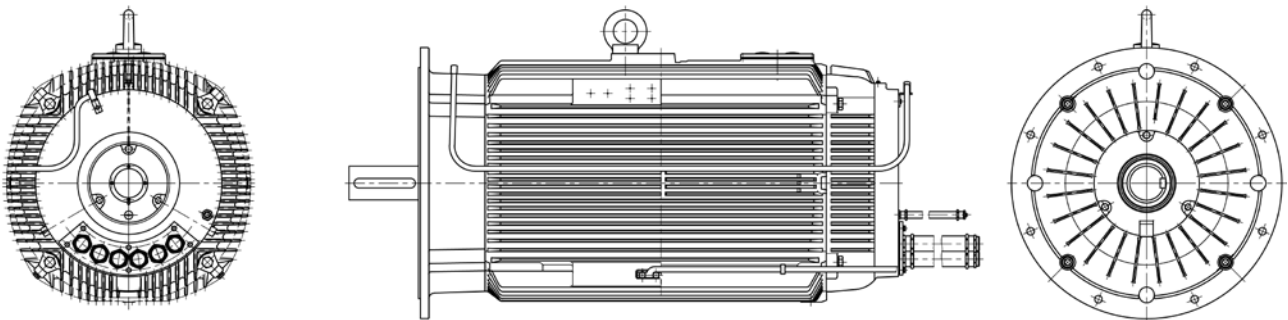

Connection cable with protective tubing, connection plate at rear end shield

Overview of technical data

The most important technical data are summarised in the following table.
Further information can be taken from the catalogue section "Introduction" (chapter 1).

Product group	Squirrel-cage rotor, IEC/DIN
Rated output	4 kW to 710 kW (IE1, IE2 and IE3 versions with 2, 4, 6 and 8 poles)
Sizes	132 to 400
Housing material	Grey cast iron
Rated torque	20 Nm to 4500 Nm
Efficiency classification/ efficiency determination	IEC/EN 60034-30-1 / IEC/EN 60034-2-1, ≤ 1 kW direct measurement, > 1 kW residual loss method
Stress temperatures in case of emergency	1 h at 200 °C, class F ₂₀₀ (60) to EN 12101-3:2015 2 h at 200 °C, class F ₂₀₀ to EN 12101-3:2015 1 h at 250 °C, class F ₂₅₀ (60) to EN 12101-3:2015 1 h at 300 °C, class F ₃₀₀ to EN 12101-3:2015 2 h at 250 °C, class F ₂₅₀ to EN 12101-3:2015 2 h at 400 °C, class F ₄₀₀ to EN 12101-3:2015
Method of connection	Single-speed motors are designed in star-delta configuration as standard.
Stator winding insulation	Thermal class 155, optional 155 [F(B)], 180 to IEC/EN 60034-1
Degree of protection	IP 55 to IEC/EN 60034-5, higher ratings as options
Type of cooling	IC 411, with self-ventilation (observe Regulations (EC) 640/2009 and (EU) 4/2014), IC 418, without self-ventilation, for incorporation into jet fans to IEC/EN 60034-6
Coolant temperature/ installation altitude	Standard -20 °C to +40 °C, Altitude 1000 m above sea level, deviating locations upon request
Rated voltage	Standard voltages to EN 60038 50 Hz: 230 V, 400 V, 500 V, 690 V, 60 Hz: 275 V, 460 V, 480 V, 600 V (Prior consultation necessary regarding 230 V, 50 Hz and 275 V, 60 Hz for motors from size 315)
Duty Types	S1, continuous duty
Types of construction	IM B3, IM B35, IM B5 and derived types to IEC/EN 60034-7
Paint finish	Normal finish "Moderate", colour RAL 7031, blue-grey Special finish "Worldwide", colour RAL 7031, blue-grey
Vibration severity grade	Grade "A" as standard for machines with no special vibration requirements
Shaft ends	to DIN 748 (IEC 60072), balanced with half-key
Limit speeds	Please refer to the section of "Limit speeds" in catalogue section "Motors for converter-fed operation", Chapter 4.
Bearing design	Please refer to the tables of bearing design data.
Motor mass	Please refer to the technical selection lists.
Terminal boxes	Please refer to the tables of "Terminal boxes" in catalogue section „Standard motors“, Chapter 2.
Documentation	The operating and maintenance manuals of the final product must be observed.
Tolerances	Please refer to the section "Tolerances" in catalogue section "Introduction", Chapter 1.
Options	Please refer to the section "Overview of modifications" in catalogue section "Introduction", Chapter 1.

Motor selection data

Three-phase motors with squirrel-cage rotor for use in powered smoke and heat extraction systems to EN 12101-3 Energy-saving motor, efficiency class Premium Efficiency IE3

with surface cooling, duty Type S1, continuous duty thermal class H, degree of protection IP 55

Type designation	Cooling IC 411 T-box at D-end	Cooling IC 411 T-box at N-end	Cooling IC 418 T-box at D-end	Cooling IC 418 T-box at N-end	Class					Cooling air									
					VEM code	F _{F200} (60)	F _{F200 + F_{F250}} (60)	F _{F300}	F _{F300}	F _{F400}	P _B	P _B	P _B	P _B	P _B	Q	v	J	m
Synchronous speed 3000 rpm – 2-pole version																			
IE3-W41R 132 SX2	IE3-Y41R 132 SX2	IE3-W41R 132 SX2 FAN	IE3-Y41R 132 SX2 FAN	5.5	4.0	4.0	4	3	6	12.5	0.035	90							
IE3-W41R 160 M2	IE3-Y41R 160 M2	IE3-W41R 160 M2 FAN	IE3-Y41R 160 M2 FAN	7.5	5.5	5.5	5.5	4	6	12.5	0.043	100							
IE3-W41R 160 MX2	IE3-Y41R 160 MX2	IE3-W41R 160 MX2 FAN	IE3-Y41R 160 MX2 FAN	11	7.5	7.5	7.5	5.5	10	12.5	0.078	125							
IE3-W41R 160 L2	IE3-Y41R 160 L2	IE3-W41R 160 L2 FAN	IE3-Y41R 160 L2 FAN	15	11.0	11.0	11	7.5	10	13.5	0.1567	175							
IE3-W41R 180 M2C	IE3-Y41R 180 M2C	IE3-W41R 180 M2C FAN	IE3-Y41R 180 M2C FAN	18.5	15.0	15.0	15	11	12	19	0.078	160							
IE3-W41R 200 L2	IE3-Y41R 200 L2	IE3-W41R 200 L2 FAN	IE3-Y41R 200 L2 FAN	22	18.5	18.5	18.5	15	14	21.0	0.1717	214							
IE3-W41R 200 LX2C	IE3-Y41R 200 LX2C	IE3-W41R 200 LX2C FAN	IE3-Y41R 200 LX2C FAN	30	22.0	22.0	22	18.5	16	22.0	0.36	305							
IE3-W41R 225 M2	IE3-Y41R 225 M2	IE3-W41R 225 M2 FAN	IE3-Y41R 225 M2 FAN	37	30.0	30.0	30	22	16	22.0	0.4757	310							
IE3-W41R 225 M2	IE3-Y41R 225 M2	IE3-W41R 225 M2 FAN	IE3-Y41R 225 M2 FAN	45	37.0	37.0	37	30	22	23.0	0.375	375							
IE3-W41R 250 M2	IE3-Y41R 250 M2	IE3-W41R 250 M2 FAN	IE3-Y41R 250 M2 FAN	55	45.0	45.0	45	37	25	23.0	0.65	510							
IE3-W41R 280 S2	IE3-Y41R 280 S2	IE3-W41R 280 S2 FAN	IE3-Y41R 280 S2 FAN	75	55.0	55.0	55	45	25	23	0.65	500							
IE3-W41R 280 M2	IE3-Y41R 280 M2	IE3-W41R 280 M2 FAN	IE3-Y41R 280 M2 FAN	90	75.0	75.0	75	55	25	23	0.675	545							
IE3-W41R 315 S2	IE3-Y41R 315 S2	IE3-W41R 315 S2 FAN	IE3-Y41R 315 S2 FAN	110	90.0	90.0	90	75	27	23.0	1.21	750							
IE3-W41R 315 M2	IE3-Y41R 315 M2	IE3-W41R 315 M2 FAN	IE3-Y41R 315 M2 FAN	132	110.0	110.0	110	90	27	23.0	1.44	815							
IE3-W41R 315 MX2	IE3-Y41R 315 MX2	IE3-W41R 315 MX2 FAN	IE3-Y41R 315 MX2 FAN	160	132.0	132.0	132	110	27	23.0	1.76	955							
IE3-W41R 315 MX2	IE3-Y41R 315 MX2	IE3-W41R 315 MX2 FAN	IE3-Y41R 315 MX2 FAN	160	160.0	160.0	160	132	27	23.0	2.37	1095							
IE3-W41R 315 MY2	IE3-Y41R 315 MY2	IE3-W41R 315 MY2 FAN	IE3-Y41R 315 MY2 FAN	200	160.0	160.0	160	160	27	23	2.82	1200							
IE3-W41R 315 L2	IE3-Y41R 315 L2	IE3-W41R 315 L2 FAN	IE3-Y41R 315 L2 FAN	250	200.0	200.0	200	160	27	23	3.66	1460							
IE3-W41R 315 LX2	IE3-Y41R 315 LX2	IE3-W41R 315 LX2 FAN	IE3-Y41R 315 LX2 FAN	315	250.0	250.0	250	200	27	23	4.43	1700							
IE3-W41R 355 M2	IE3-Y41R 355 M2	IE3-W41R 355 M2 FAN	IE3-Y41R 355 M2 FAN	355	315.0	315.0	315	250	75	23.0	4.2	2000							
IE3-W42R 355 MX2	IE3-Y42R 355 MX2	IE3-W42R 355 MX2 FAN	IE3-Y42R 355 MX2 FAN	400	355.0	355.0	355	315	***	***	5.5	2200							
IE3-W42R 355 L2	IE3-Y42R 355 L2	IE3-W42R 355 L2 FAN	IE3-Y42R 355 L2 FAN	500	400.0	400.0	400	355	***	***	7.1	2445							
IE3-W42R 400 M2	IE3-Y42R 400 M2	IE3-W42R 400 M2 FAN	IE3-Y42R 400 M2 FAN	560	500.0	500.0	500	400	***	***	8.44	3000							
IE3-W42R 400 MX2	IE3-Y42R 400 MX2	IE3-W42R 400 MX2 FAN	IE3-Y42R 400 MX2 FAN	630	560.0	560.0	560	500	***	***	9.41	3200							
IE3-W42R 400 L2	IE3-Y42R 400 L2	IE3-W42R 400 L2 FAN	IE3-Y42R 400 L2 FAN	710	630.0	630.0	630	560	***	***	10.41	3450							
Synchronous speed 1500 rpm – 4-pole version																			
IE3-W41R 132 S4	IE3-Y41R 132 S4	IE3-W41R 132 S4 FAN	IE3-Y41R 132 S4 FAN	5.5	4.0	4.0	4	3	6	12.5	0.035	90							
IE3-W41R 132 M4	IE3-Y41R 132 M4	IE3-W41R 132 M4 FAN	IE3-Y41R 132 M4 FAN	7.5	5.5	5.5	5.5	4	6	12.5	0.043	100							
IE3-W41R 160 M4	IE3-Y41R 160 M4	IE3-W41R 160 M4 FAN	IE3-Y41R 160 M4 FAN	11	7.5	7.5	7.5	5.5	10	12.5	0.078	125							
IE3-W41R 160 L4C	IE3-Y41R 160 L4C	IE3-W41R 160 L4C FAN	IE3-Y41R 160 L4C FAN	15	11.0	11.0	11	7.5	10	13.5	0.1567	175							
IE3-W41R 180 M4	IE3-Y41R 180 M4	IE3-W41R 180 M4 FAN	IE3-Y41R 180 M4 FAN	18.5	15.0	15.0	15	11	11	14.0	0.168	210							
IE3-W41R 180 L4	IE3-Y41R 180 L4	IE3-W41R 180 L4 FAN	IE3-Y41R 180 L4 FAN	22	18.5	18.5	18.5	15	11	14.0	0.203	240							
IE3-W41R 200 L4C	IE3-Y41R 200 L4C	IE3-W41R 200 L4C FAN	IE3-Y41R 200 L4C FAN	30	22.0	22.0	22	18.5	15	14.5	0.411	327							
IE3-W41R 225 S4C	IE3-Y41R 225 S4C	IE3-W41R 225 S4C FAN	IE3-Y41R 225 S4C FAN	37	30.0	30.0	30	22	15	14.5	0.4675	367							
IE3-W41R 225 M4	IE3-Y41R 225 M4	IE3-W41R 225 M4 FAN	IE3-Y41R 225 M4 FAN	45	37.0	37.0	37	30	21	15.0	0.619	450							
IE3-W41R 250 M4	IE3-Y41R 250 M4	IE3-W41R 250 M4 FAN	IE3-Y41R 250 M4 FAN	55	45.0	45.0	45	37	32	20.0	0.95	550							
IE3-W41R 280 S4	IE3-Y41R 280 S4	IE3-W41R 280 S4 FAN	IE3-Y41R 280 S4 FAN	75	55.0	55.0	55	45	32	20.0	1.1	617							
IE3-W41R 280 M4	IE3-Y41R 280 M4	IE3-W41R 280 M4 FAN	IE3-Y41R 280 M4 FAN	90	75.0	75.0	75	55	45	20.0	1.96	785							
IE3-W41R 315 S4	IE3-Y41R 315 S4	IE3-W41R 315 S4 FAN	IE3-Y41R 315 S4 FAN	110	90.0	90.0	90	75	45	20	1.96	760							
IE3-W41R 315 M4	IE3-Y41R 315 M4	IE3-W41R 315 M4 FAN	IE3-Y41R 315 M4 FAN	132	110.0	110.0	110	90	45	20	2.27	850							
IE3-W41R 315 MX4	IE3-Y41R 315 MX4	IE3-W41R 315 MX4 FAN	IE3-Y41R 315 MX4 FAN	160	132.0	132.0	132	110	45	20	2.73	975							
IE3-W41R 315 MX4	IE3-Y41R 315 MX4	IE3-W41R 315 MX4 FAN	IE3-Y41R 315 MX4 FAN	160	160.0	160.0	160	132	45	20	4.01	1120							
IE3-W41R 315 MY4	IE3-Y41R 315 MY4	IE3-W41R 315 MY4 FAN	IE3-Y41R 315 MY4 FAN	200	160.0	160.0	160	160	45	20	4.82	1250							
IE3-W41R 315 L4	IE3-Y41R 315 L4	IE3-W41R 315 L4 FAN	IE3-Y41R 315 L4 FAN	250	200.0	200.0	200	160	45	20	5.93	1450							
IE3-W41R 315 LX4	IE3-Y41R 315 LX4	IE3-W41R 315 LX4 FAN	IE3-Y41R 315 LX4 FAN	315	250.0	250.0	250	200	45	20	6.82	1630							
IE3-W41R 355 M 4	IE3-Y41R 355M 4	IE3-W41R 355M 4 FAN	IE3-Y41R 355M 4 FAN	355	315.0	315.0	315	250	72	20.0	7.9	2150							
IE3-W42R 355 MX4	IE3-Y42R 355 MX4	IE3-W42R 355 MX4 FAN	IE3-Y42R 355 MX4 FAN	400	355.0	355.0	355	315	***	***	9.5	2400							
IE3-W42R 355 L4	IE3-Y42R 355 L4	IE3-W42R 355 L4 FAN	IE3-Y42R 355 L4 FAN	500	400.0	400.0	400	355	***	***	10	2500							
IE3-W42R 400 M4	IE3-Y42R 400 M4	IE3-W42R 400 M4 FAN	IE3-Y42R 400 M4 FAN	560	500.0	500.0	500	400	***	***	12.6	2900							
IE3-W42R 400 MX4	IE3-Y42R 400 MX4	IE3-W42R 400 MX4 FAN	IE3-Y42R 400 MX4 FAN	630	560.0	560.0	560	500	***	***	14.33	3100							
IE3-W42R 400 L4	IE3-Y42R 400 L4	IE3-W42R 400 L4 FAN	IE3-Y42R 400 L4 FAN	710	630.0	630.0	630	560	***	***	16.29	3400							

*** upon request

Three-phase motors with squirrel-cage rotor for use in powered smoke and heat extraction systems to EN 12101-3
Energy-saving motor, efficiency class Premium Efficiency IE3

with surface cooling, duty Type S1, continuous duty thermal class H, degree of protection IP 55

				Class		Thermal stress							
				F ₂₀₀ (60)	F ₂₀₀ + F ₂₅₀ (60)	F ₃₀₀	F ₃₀₀	F ₃₀₀	F ₄₀₀				
				1h/200 °C	2h/200 °C + 1h/250 °C	1h/300 °C	2h/300 °C	2h/300 °C	2h/400 °C				
				VEM code	FV	FV1-1	FV2-1	FV3-1	FV4-4				
Type designation				Rated output					Cooling air				
Cooling IC 411	Cooling IC 411	Cooling IC 418	Cooling IC 418	P _B	P _B	P _B	P _B	P _B	Q	v	J	m	
T-box at D-end	T-box at N-end	T-box at D-end	T-box at N-end	kW	kW	kW	kW	kW	m ³ /min	ms ⁻¹	kgm ²	kg	
Synchronous speed 1000 rpm – 6-pole version													
IE3-W41R 132 M6	IE3-Y41R 132 M6	IE3-W41R 132 M6 FAN	IE3-Y41R 132 M6 FAN	4	3.0	3.0	3	2.2	4	9.5	0.043	75	
IE3-W41R 132 MX6	IE3-Y41R 132 MX6	IE3-W41R 132 MX6 FAN	IE3-Y41R 132 MX6 FAN	5.5	4.0	4.0	4	3	4	10.5	0.053	105	
IE3-W41R 160 M6	IE3-Y41R 160 M6	IE3-W41R 160 M6 FAN	IE3-Y41R 160 M6 FAN	7.5	5.5	5.5	5.5	4	5	11.0	0.145	145	
IE3-W41R 160 L6C	IE3-Y41R 160 L6C	IE3-W41R 160 L6C FAN	IE3-Y41R 160 L6C FAN	11	7.5	7.5	7.5	5.5	5	11.0	0.166	168	
IE3-W41R 180 L6C	IE3-Y41R 180 L6C	IE3-W41R 180 L6C FAN	IE3-Y41R 180 L6C FAN	15	11.0	11.0	11	7.5	8	11.5	0.3396	214	
IE3-W41R 200 L6	IE3-Y41R 200 L6	IE3-W41R 200 L6 FAN	IE3-Y41R 200 L6 FAN	18.5	15.0	15.0	15	11	10	12.0	0.514	310	
IE3-W41R 200 LX6C	IE3-Y41R 200 LX6C	IE3-W41R 200 LX6C FAN	IE3-Y41R 200 LX6C FAN	22	18.5	18.5	18.5	15	10	12.0	0.6476	321	
IE3-W41R 225 M6	IE3-Y41R 225 M6	IE3-W41R 225 M6 FAN	IE3-Y41R 225 M6 FAN	30	22.0	22.0	22	18.5	14	12.5	0.92	400	
IE3-W41R 250 M6	IE3-Y41R 250 M6	IE3-W41R 250 M6 FAN	IE3-Y41R 250 M6 FAN	37	30.0	30.0	30	22	21	15.0	1.48	545	
IE3-W41R 280 S6	IE3-Y41R 280 S6	IE3-W41R 280 S6 FAN	IE3-Y41R 280 S6 FAN	45	37.0	37.0	37	30	30	20.0	2.63	695	
IE3-W41R 280 M6	IE3-Y41R 280 M6	IE3-W41R 280 M6 FAN	IE3-Y41R 280 M6 FAN	55	45.0	45.0	45	37	30	20.0	3.33	815	
IE3-W41R 315 S6	IE3-Y41R 315 S6	IE3-W41R 315 S6 FAN	IE3-Y41R 315 S6 FAN	75	55.0	55.0	55	45	30	20.0	3.6	910	
IE3-W41R 315 S6	IE3-Y41R 315 S6	IE3-W41R 315 S6 FAN	IE3-Y41R 315 S6 FAN	75	75.0	75.0	75	55	30	20.0	5.55	1060	
IE3-W41R 315 M6	IE3-Y41R 315 M6	IE3-W41R 315 M6 FAN	IE3-Y41R 315 M6 FAN	90	75.0	75.0	75	75	30	20.0	6	1100	
IE3-W41R 315 MX6	IE3-Y41R 315 MX6	IE3-W41R 315 MX6 FAN	IE3-Y41R 315 MX6 FAN	110	90.0	90.0	90	75	30	20.0	6.67	1210	
IE3-W41R 315 L6	IE3-Y41R 315 L6	IE3-W41R 315 L6 FAN	IE3-Y41R 315 L6 FAN	132	110.0	110.0	110	90	30	20.0	8.6	1550	
IE3-W41R 355 M6	IE3-Y41R 355 M6	IE3-W41R 355 M6 FAN	IE3-Y41R 355 M6 FAN	160	132.0	132.0	132	110	54	20.0	8.2	1850	
IE3-W41R 355 MX6	IE3-Y41R 355 MX6	IE3-W41R 355 MX6 FAN	IE3-Y41R 355 MX6 FAN	200	160.0	160.0	160	132	54	20.0	12.1	2200	
IE3-W42R 355 MX6	IE3-Y42R 355 MX6	IE3-W42R 355 MX6 FAN	IE3-Y42R 355 MX6 FAN	200	200.0	200.0	200	160	54	20.0	12.1	2350	
IE3-W42R 355 L6	IE3-Y42R 355 L6	IE3-W42R 355 L6 FAN	IE3-Y42R 355 L6 FAN	250	200.0	200.0	200	200	54	20.0	14	2400	
IE3-W42R 355 LX6	IE3-Y42R 355 LX6	IE3-W42R 355 LX6 FAN	IE3-Y42R 355 LX6 FAN	315	250.0	250.0	250	200	54	20.0	14	2400	
IE3-W42R 400 MY6	IE3-Y42R 400 MY6	IE3-W42R 400 MY6 FAN	IE3-Y42R 400 MY6 FAN	355	315.0	315.0	315	250	***	***	16.54	2900	
IE3-W42R 400 M6	IE3-Y42R 400 M6	IE3-W42R 400 M6 FAN	IE3-Y42R 400 M6 FAN	400	355.0	355.0	355	315	***	***	16.54	2900	
IE3-W42R 400 MX6	IE3-Y42R 400 MX6	IE3-W42R 400 MX6 FAN	IE3-Y42R 400 MX6 FAN	450	400.0	400.0	400	355	***	***	18.44	3100	
IE3-W42R 400 L6	IE3-Y42R 400 L6	IE3-W42R 400 L6 FAN	IE3-Y42R 400 L6 FAN	500	450.0	450.0	450	400	***	***	20.63	3400	

Synchronous speed 750 rpm – 8-pole version												
IE3-W41R 132 M8	IE3-Y41R 132 M8	IE3-W41R 132 M8 FAN	IE3-Y41R 132 M8 FAN	3	2.2	2.2	2.2	1.5	3	8.5	0.043	74
IE3-W41R 160 M8	IE3-Y41R 160 M8	IE3-W41R 160 M8 FAN	IE3-Y41R 160 M8 FAN	4	3.0	3.0	3	2.2	3	8.5	0.113	114
IE3-W41R 160 MX8	IE3-Y41R 160 MX8	IE3-W41R 160 MX8 FAN	IE3-Y41R 160 MX8 FAN	5.5	4.0	4.0	4	3	4	9.0	0.145	143
IE3-W41R 160 L8	IE3-Y41R 160 L8	IE3-W41R 160 L8 FAN	IE3-Y41R 160 L8 FAN	7.5	5.5	5.5	5.5	4	4	9.0	0.166	155
IE3-W41R 180 L8	IE3-Y41R 180 L8	IE3-W41R 180 L8 FAN	IE3-Y41R 180 L8 FAN	11	7.5	7.5	7.5	5.5	8	9.5	0.228	175
IE3-W41R 200 L8	IE3-Y41R 200 L8	IE3-W41R 200 L8 FAN	IE3-Y41R 200 L8 FAN	15	11.0	11.0	11	7.5	8	9.5	0.324	235
IE3-W41R 225 S8	IE3-Y41R 225 S8	IE3-W41R 225 S8 FAN	IE3-Y41R 225 S8 FAN	18.5	15.0	15.0	15	11	11	10.0	0.514	310
IE3-W41R 225 M8	IE3-Y41R 225 M8	IE3-W41R 225 M8 FAN	IE3-Y41R 225 M8 FAN	22	18.5	18.5	18.5	15	16	10.5	0.825	360
IE3-W41R 250 M8	IE3-Y41R 250 M8	IE3-W41R 250 M8 FAN	IE3-Y41R 250 M8 FAN	30	22.0	22.0	22	18.5	16	15.0	0.92	400
IE3-W41R 280 S8	IE3-Y41R 280 S8	IE3-W41R 280 S8 FAN	IE3-Y41R 280 S8 FAN	37	30.0	30.0	30	22	21	15.0	1.55	520
IE3-W41R 280 M8	IE3-Y41R 280 M8	IE3-W41R 280 M8 FAN	IE3-Y41R 280 M8 FAN	45	37.0	37.0	37	30	21	15.0	2.63	700
IE3-W41R 315 S8	IE3-Y41R 315 S8	IE3-W41R 315 S8 FAN	IE3-Y41R 315 S8 FAN	55	45.0	45.0	45	37				
IE3-W41R 315 S8	IE3-Y41R 315 S8	IE3-W41R 315 S8 FAN	IE3-Y41R 315 S8 FAN	55	55.0	55.0	55	45	21	15.0	3.33	800
IE3-W41R 315 M8	IE3-Y41R 315 M8	IE3-W41R 315 M8 FAN	IE3-Y41R 315 M8 FAN	75	55.0	55.0	55	55	21	15.0	5.55	1060
IE3-W41R 315 MX8	IE3-Y41R 315 MX8	IE3-W41R 315 MX8 FAN	IE3-Y41R 315 MX8 FAN	90	75.0	75.0	75	55	21	15.0	6	1100
IE3-W41R 315 L8	IE3-Y41R 315 L8	IE3-W41R 315 L8 FAN	IE3-Y41R 315 L8 FAN	110	90.0	90.0	90	75	21	15.0	8.71	1450
IE3-W41R 355 M8	IE3-Y41R 355 M8	IE3-W41R 355 M8 FAN	IE3-Y41R 355 M8 FAN	132	110.0	110.0	110	90	40	15	9.5	1890
IE3-W42R 355 MX8	IE3-Y42R 355 MX8	IE3-W42R 355 MX8 FAN	IE3-Y42R 355 MX8 FAN	160	132.0	132.0	132	110	40	15	13.4	2200
IE3-W42R 355 L8	IE3-Y42R 355 L8	IE3-W42R 355 L8 FAN	IE3-Y42R 355 L8 FAN	200	160.0	160.0	160	132	40	15	15.8	2400
IE3-W42R 355 LX8	IE3-Y42R 355 LX8	IE3-W42R 355 LX8 FAN	IE3-Y42R 355 LX8 FAN	250	200.0	200.0	200	160	40	15	15.8	2400
IE3-W42R 400 MY8	IE3-Y42R 400 MY8	IE3-W42R 400 MY8 FAN	IE3-Y42R 400 MY8 FAN	315	250.0	250.0	250	200	***	***	17.94	2800
IE3-W42R 400 M8	IE3-Y42R 400 M8	IE3-W42R 400 M8 FAN	IE3-Y42R 400 M8 FAN	355	315.0	315.0	315	250	***	***	17.94	2900
IE3-W42R 400 MX8	IE3-Y42R 400 MX8	IE3-W42R 400 MX8 FAN	IE3-Y42R 400 MX8 FAN	400	355.0	355.0	355	315	***	***	19.99	3100
IE3-W42R 400 L8	IE3-Y42R 400 L8	IE3-W42R 400 L8 FAN	IE3-Y42R 400 L8 FAN	450	400.0	400.0	400	355	***	***	22.34	3400

***) upon request

Three-phase motors with squirrel-cage rotor for use in powered smoke and heat extraction systems to EN 12101-3

Energy-saving motor, efficiency class High Efficiency IE2

with surface cooling, duty Type S1, continuous duty thermal class H, degree of protection IP 55

Type designation				Class						Cooling air			
				Thermal stress		F ₂₀₀ (60)		F ₃₀₀		F ₄₀₀		Q	v
VEM code				1h/200 °C	2h/200 °C + 1h/250 °C	1h/300 °C	2h/300 °C	2h/400 °C	m³ /min	ms ⁻¹	kgm²	kg	
Rated output				P _B	P _B	P _B	P _B	P _B					
Cooling IC 411				kW	kW	kW	kW	kW					
Cooling IC 418				kW	kW	kW	kW	kW					
Cooling IC 418				kW	kW	kW	kW	kW					
Cooling IC 418				kW	kW	kW	kW	kW					
Synchronous speed 3000 rpm – 2-pole version													
IE2-WE1R 132 SX2	IE2-YE1R 132 SX2	IE2-WE1R 132 SX2 FAN	IE2-YE1R 132 SX2 FAN	7.5	7.5	5.5	5.5	4	7	19	0.0168	75	
IE2-WE1R 160 M2	IE2-YE1R 160 M2	IE2-WE1R 160 M2 FAN	IE2-YE1R 160 M2 FAN	11	11.0	7.5	7.5	5.5	12	19	0.0258	125	
IE2-WE1R 160 MX2	IE2-YE1R 160 MX2	IE2-WE1R 160 MX2 FAN	IE2-YE1R 160 MX2 FAN	15	15.0	11.0	11	7.5	12	19	0.0675	140	
IE2-WE1R 160 L2	IE2-YE1R 160 L2	IE2-WE1R 160 L2 FAN	IE2-YE1R 160 L2 FAN	18.5	18.5	15.0	15	11	12	19	0.0675	140	
IE2-WE1R 180 M2	IE2-YE1R 180 M2	IE2-WE1R 180 M2 FAN	IE2-YE1R 180 M2 FAN	22	22.0	18.5	18.5	15	14	20	0.105	173	
IE2-WE1R 200 L2	IE2-YE1R 200 L2	IE2-WE1R 200 L2 FAN	IE2-YE1R 200 L2 FAN	30	30.0	22.0	22	22	14	20	0.128	210	
IE2-WE1R 200 LX2	IE2-YE1R 200 LX2	IE2-WE1R 200 LX2 FAN	IE2-YE1R 200 LX2 FAN	37	37.0	30.0	30	30	14	20	0.154	233	
IE2-WE1R 225 M2	IE2-YE1R 225 M2	IE2-WE1R 225 M2 FAN	IE2-YE1R 225 M2 FAN	45	45.0	37.0	37	37	16	21	0.360	295	
IE2-WE1R 250 M2	IE2-YE1R 250 M2	IE2-WE1R 250 M2 FAN	IE2-YE1R 250 M2 FAN	55	55.0	45.0	45	45	22	23	0.375	385	
IE2-WE1R 280 S2	IE2-YE1R 280 S2	IE2-WE1R 280 S2 FAN	IE2-YE1R 280 S2 FAN	75	75.0	55.0	55	55	25	23	0.65	510	
IE2-WE1R 280 M2	IE2-YE1R 280 M2	IE2-WE1R 280 M2 FAN	IE2-YE1R 280 M2 FAN	90	90.0	75.0	75	75	25	23	0.68	550	
IE2-WE1R 315 S2	IE2-YE1R 315 S2	IE2-WE1R 315 S2 FAN	IE2-YE1R 315 S2 FAN	110	110.0	90.0	90	90	27	23	1.21	730	
IE2-WE1R 315 M2	IE2-YE1R 315 M2	IE2-WE1R 315 M2 FAN	IE2-YE1R 315 M2 FAN	132	132.0	110.0	110	110	27	23	1.44	820	
IE2-WE1R 315 MX2	IE2-YE1R 315 MX2	IE2-WE1R 315 MX2 FAN	IE2-YE1R 315 MX2 FAN	160	160.0	132.0	132	132	27	23	1.76	955	
IE2-WE1R 315 MY2	IE2-YE1R 315 MY2	IE2-WE1R 315 MY2 FAN	IE2-YE1R 315 MY2 FAN	200	200.0	160.0	160	160	27	23	2.82	1200	
IE2-WE1R 315 L2	IE2-YE1R 315 L2	IE2-WE1R 315 L2 FAN	IE2-YE1R 315 L2 FAN	250	250.0	200.0	200	200	27	23	3.66	1450	
IE2-WE1R 315 LX2	IE2-YE1R 315 LX2	IE2-WE1R 315 LX2 FAN	IE2-YE1R 315 LX2 FAN	315	315.0	250.0	250	250	27	23	4.43	1700	
IE2-WE2R 355 M2	IE2-YE2R 355 M2	IE2-WE2R 355 M2 FAN	IE2-YE2R 355 M2 FAN	355	355.0	355.0	300	300	75	23	4.20	2000	
IE2-WE2R 355 MX2	YE2R 355 MX2	IE2-WE2R 355 MX2 FAN	IE2-YE2R 355 MX2 FAN	400	400.0	400.0	340	340	75	23	4.50	2200	
IE2-WE2R 355 L2	YE2R 355 L2	IE2-WE2R 355 L2 FAN	IE2-YE2R 355 L2 FAN	450	450.0	450.0	420	420	75	23	7.10	2400	
Synchronous speed 1500 rpm – 4-pole version													
IE2-WE1R 132 M4	IE2-YE1R 132 M4	IE2-WE1R 132 M4 FAN	IE2-YE1R 132 M4 FAN	7.5	7.5	5.5	5.5	4	5.5	12.5	0.035	88	
IE2-WE1R 160 M4	IE2-YE1R 160 M4	IE2-WE1R 160 M4 FAN	IE2-YE1R 160 M4 FAN	11.0	11.0	7.5	7.5	5.5	10	13.5	0.078	122	
IE2-WE1R 160 L4	IE2-YE1R 160 L4	IE2-WE1R 160 L4 FAN	IE2-YE1R 160 L4 FAN	15.0	15.0	11.0	11	7.5	10	13.5	0.115	160	
IE2-WE1R 180 M4	IE2-YE1R 180 M4	IE2-WE1R 180 M4 FAN	IE2-YE1R 180 M4 FAN	18.5	18.5	15.0	15	11	11	14	0.168	207	
IE2-WE1R 180 L4	IE2-YE1R 180 L4	IE2-WE1R 180 L4 FAN	IE2-YE1R 180 L4 FAN	22	22.0	18.5	18.5	15	11	14	0.168	215	
IE2-WE1R 200 L4	IE2-YE1R 200 L4	IE2-WE1R 200 L4 FAN	IE2-YE1R 200 L4 FAN	30	30.0	22.0	22	18.5	15	14.5	0.275	277	
IE2-WE1R 225 S4	IE2-YE1R 225 S4	IE2-WE1R 225 S4 FAN	IE2-YE1R 225 S4 FAN	37	37.0	30.0	30	30	15	14.5	0.313	313	
IE2-WE1R 225 M4	IE2-YE1R 225 M4	IE2-WE1R 225 M4 FAN	IE2-YE1R 225 M4 FAN	45	45.0	37.0	37	37	21	15	0.525	390	
IE2-WE1R 250 M4	IE2-YE1R 250 M4	IE2-WE1R 250 M4 FAN	IE2-YE1R 250 M4 FAN	55	55.0	45.0	45	45			0.95	535	
IE2-WE1R 280 S4	IE2-YE1R 280 S4	IE2-WE1R 280 S4 FAN	IE2-YE1R 280 S4 FAN	75	75.0	55.0	55	55	32	20	0.95	550	
IE2-WE1R 280 M4	IE2-YE1R 280 M4	IE2-WE1R 280 M4 FAN	IE2-YE1R 280 M4 FAN	90	90.0	75.0	75	75	32	20	1.10	610	
IE2-WE1R 315 S4	IE2-YE1R 315 S4	IE2-W21R 315 S4 FAN	IE2-YE1R 315 S4 FAN	110	110.0	90.0	90	90	45	20	1.96	760	
IE2-WE1R 315 M4	IE2-YE1R 315 M4	IE2-W21R 315 M4 FAN	IE2-YE1R 315 M4 FAN	132	132.0	110.0	110	110	45	20	2.27	850	
IE2-WE1R 315 MX4	IE2-YE1R 315 MX4	IE2-W21R 315 MX4 FAN	IE2-YE1R 315 MX4 FAN	160	160.0	132.0	132	132	45	20	2.73	975	
IE2-WE1R 315 MY4	IE2-YE1R 315 MY4	IE2-W21R 315 MY4 FAN	IE2-YE1R 315 MY4 FAN	200	200.0	160.0	160	160	45	20	4.82	1270	
IE2-WE1R 315 L4	IE2-YE1R 315 L4	IE2-W21R 315 L4 FAN	IE2-YE1R 315 L4 FAN	250	250.0	200.0	200	200	45	20	5.93	1450	
IE2-WE1R 315 LX4	IE2-YE1R 315 LX4	IE2-W21R 315 LX4 FAN	IE2-YE1R 315 LX4 FAN	315	315.0	250.0	250	250	45	20	6.82	1630	
IE2-WE2R 355 M4	IE2-YE2R 355 M4	IE2-WE2R 355 M4 FAN	IE2-YE2R 355 M4 FAN	355	355.0	355.0	340	300	72	20	7.90	2150	
IE2-WE2R 355 MX4	YE2R 355 MX4	IE2-WE2R 355 MX4 FAN	IE2-YE2R 355 MX4 FAN	400	400.0	400.0	380	340	72	20	9.50	2400	
IE2-WE2R 355 LY4	YE2R 355 LY4	IE2-WE2R 355 LY4 FAN	IE2-YE2R 355 LY4 FAN					380	81	20	10.00	2500	
IE2-WE2R 355 L4	YE2R 355 L4	IE2-WE2R 355 L4 FAN	IE2-YE2R 355 L4 FAN	450	450.0	450.0	420	420	81	20	10.00	2500	

Three-phase motors with squirrel-cage rotor for use in powered smoke and heat extraction systems to EN 12101-3
Energy-saving motor, efficiency class High Efficiency IE2

with surface cooling, duty Type S1, continuous duty thermal class H, degree of protection IP 55

				Class		Thermal stress							
				$F_{200}(60)$	F_{300}	$F_{200} + F_{250}(60)$	F_{300}	F_{300}	F_{400}				
				1h/200 °C	1h/300 °C	2h/200 °C + 1h/250 °C	1h/300 °C	2h/300 °C	2h/400 °C				
				VEM code	FV	FV1-1	FV2-1	FV3-1	FV4-4				
Type designation				Rated output					Cooling air				
Cooling IC 411	Cooling IC 411	Cooling IC 418	Cooling IC 418	P_B	P_B	P_B	P_B	P_B	Q	v	J	m	
T-box at D-end	T-box at N-end	T-box at D-end	T-box at N-end	kW	kW	kW	kW	kW	m ³ /min	ms ⁻¹	kgm ²	kg	
Synchronous speed 1000 rpm – 6-pole version													
IE2-WE1R 132 M6	IE2-YE1R 132 M6	IE2-WE1R 132 M6 FAN	IE2-YE1R 132 M6 FAN	4.0	4.0	3.0	3	2.2	4	9.5	0.029	76	
IE2-WE1R 132 MX6	IE2-YE1R 132 MX6	IE2-WE1R 132 MX6 FAN	IE2-YE1R 132 MX6 FAN	5.5	5.5	4.0	4	3	4	9.5	0.113	85	
IE2-WE1R 160 M6	IE2-YE1R 160 M6	IE2-WE1R 160 M6 FAN	IE2-YE1R 160 M6 FAN	7.5	7.5	5.5	5.5	4	5	10.5	0.066	118	
IE2-WE1R 160 L6	IE2-YE1R 160 L6	IE2-WE1R 160 L6 FAN	IE2-YE1R 160 L6 FAN	11.0	11.0	7.5	7.5	5.5	5	10.5	0.166	135	
IE2-WE1R 180 L6	IE2-YE1R 180 L6	IE2-WE1R 180 L6 FAN	IE2-YE1R 180 L6 FAN	15.0	15.0	11.0	11	7.5	8	11.5	0.228	185	
IE2-WE1R 200 L6	IE2-YE1R 200 L6	IE2-WE1R 200 L6 FAN	IE2-YE1R 200 L6 FAN	18.5	18.5	15.0	15	11	8	11.5	0.268	208	
IE2-WE1R 200 LX6	IE2-YE1R 200 LX6	IE2-WE1R 200 LX6 FAN	IE2-YE1R 200 LX6 FAN	22	22.0	18.5	18.5	15	10	12	0.443	272	
IE2-WE1R 225 M6	IE2-YE1R 225 M6	IE2-WE1R 225 M6 FAN	IE2-YE1R 225 M6 FAN	30	30.0	22.0	22	22	14	12.5	0.825	365	
IE2-WE1R 250 M6	IE2-YE1R 250 M6	IE2-WE1R 250 M6 FAN	IE2-YE1R 250 M6 FAN	37	37.0	30.0	30	30	10	12	1.28	485	
IE2-WE1R 280 S6	IE2-YE1R 280 S6	IE2-WE1R 280 S6 FAN	IE2-YE1R 280 S6 FAN	45	45.0	37.0	37	37	10	12	1.48	560	
IE2-WE1R 280 M6	IE2-YE1R 280 M6	IE2-WE1R 280 M6 FAN	IE2-YE1R 280 M6 FAN	55	55.0	45.0	45	45	30	20	2.63	710	
IE2-WE1R 315 S6	IE2-YE1R 315 S6	IE2-WE1R 315 S6 FAN	IE2-YE1R 315 S6 FAN	75	75.0	55.0	55	55	30	20	3.33	804	
IE2-WE1R 315 M6	IE2-YE1R 315 M6	IE2-WE1R 315 M6 FAN	IE2-YE1R 315 M6 FAN	90	90.0	75.0	75	75	30	20	3.60	865	
IE2-WE1R 315 MX6	IE2-YE1R 315 MX6	IE2-WE1R 315 MX6 FAN	IE2-YE1R 315 MX6 FAN	110	110.0	90.0	90	90	30	20	6.67	1210	
IE2-WE1R 315 MY6	IE2-YE1R 315 MY6	IE2-WE1R 315 MY6 FAN	IE2-YE1R 315 MY6 FAN	132	132.0	110.0	110	110	30	20	6.67	1250	
IE2-WE1R 315 L6	IE2-YE1R 315 L6	IE2-WE1R 315 L6 FAN	IE2-YE1R 315 L6 FAN	160	160.0	132.0	132	132	30	20	8.60	1430	
IE2-WE1R 315 LX6	IE2-YE1R 315 LX6	IE2-WE1R 315 LX6 FAN	IE2-YE1R 315 LX6 FAN	200	200.0	160.0	160	160	30	20	8.60	1460	
IE2-WE2R 355 M6	IE2-YE2R 355 M6	IE2-WE2R 355 M6 FAN	IE2-YE2R 355 M6 FAN	250	250.0	200.0	200	200	54	20	8.20	1850	
IE2-WE2R 355 MX6	IE2-YE2R 355 MX6	IE2-WE2R 355 MX6 FAN	IE2-YE2R 355 MX6 FAN	315	315.0	250.0	250	250	54	20	12.10	2200	
IE2-WE2R 355 LY6	IE2-YE2R 355 LY6	IE2-WE2R 355 LY6 FAN	IE2-YE2R 355 LY6 FAN	355	355.0	315.0	300	300	54	20	14.00	2400	
Synchronous speed 750 rpm – 8-pole version													
IE2-W41R 132 M8	IE2-Y41R 132 M8	IE2-W41R 132 M8 FAN	IE2-Y41R 132 M8 FAN	3	2.2	2.2	2.2	1.5	3	8.5	0.043	74	
IE2-WE1R 132 M8	IE2-YE1R 132 M8	IE2-WE1R 132 M8 FAN	IE2-YE1R 132 M8 FAN	3.0	3.0	2.2	2.2	1.5	3	8.5	0.0430	74	
IE2-WE1R 160 M8	IE2-YE1R 160 M8	IE2-WE1R 160 M8 FAN	IE2-YE1R 160 M8 FAN	4.0	4.0	3.0	3	2.2	3	8.5	0.0530	86	
IE2-WE1R 160 MX8	IE2-YE1R 160 MX8	IE2-WE1R 160 MX8 FAN	IE2-YE1R 160 MX8 FAN	5.5	5.5	4.0	4	3	4	8.5	0.1130	115	
IE2-WE1R 160 L8	IE2-YE1R 160 L8	IE2-WE1R 160 L8 FAN	IE2-YE1R 160 L8 FAN	7.5	7.5	5.5	5.5	4	4	8.5	0.1450	136	
IE2-WE1R 180 L8	IE2-YE1R 180 L8	IE2-WE1R 180 L8 FAN	IE2-YE1R 180 L8 FAN	11.0	11.0	7.5	7.5	5.5	8	9.5	0.2280	175	
IE2-WE1R 200 L8	IE2-YE1R 200 L8	IE2-WE1R 200 L8 FAN	IE2-YE1R 200 L8 FAN	15.0	15.0	11.0	11	7.5	8	9.5	0.2680	200	
IE2-WE1R 225 S8	IE2-YE1R 225 S8	IE2-WE1R 225 S8 FAN	IE2-YE1R 225 S8 FAN	18.5	18.5	15.0	15	11	8	10	0.44	265	
IE2-WE1R 225 M8	IE2-YE1R 225 M8	IE2-WE1R 225 M8 FAN	IE2-YE1R 225 M8 FAN	22	22.0	18.5	18.5	15	16	10.5	0.83	380	
IE2-WE1R 250 M8	IE2-YE1R 250 M8	IE2-WE1R 250 M8 FAN	IE2-YE1R 250 M8 FAN	30	30.0	22.0	22	22	16	15	1.35	480	
IE2-WE1R 280 S8	IE2-YE1R 280 S8	IE2-WE1R 280 S8 FAN	IE2-YE1R 280 S8 FAN	37	37.0	30.0	30	30	16	15	1.55	550	
IE2-WE1R 280 M8	IE2-YE1R 280 M8	IE2-WE1R 280 M8 FAN	IE2-YE1R 280 M8 FAN	45	45.0	37.0	37	37	21	15	2.63	690	
IE2-WE1R 315 S8	IE2-YE1R 315 S8	IE2-WE1R 315 S8 FAN	IE2-YE1R 315 S8 FAN	55	55.0	45.0	45	45	21	15	3.33	800	
IE2-WE1R 315 M8	IE2-YE1R 315 M8	IE2-WE1R 315 M8 FAN	IE2-YE1R 315 M8 FAN	75	75.0	55.0	55	55	21	15	3.6	880	
IE2-WE1R 315 MX8	IE2-YE1R 315 MX8	IE2-WE1R 315 MX8 FAN	IE2-YE1R 315 MX8 FAN	90	90.0	75.0	75	75	21	15	6	1050	
IE2-WE1R 315 MY8	IE2-YE1R 315 MY8	IE2-WE1R 315 MY8 FAN	IE2-YE1R 315 MY8 FAN	110	110.0	90.0	90	90	21	15	6.76	1250	
IE2-WE1R 315 L8	IE2-YE1R 315 L8	IE2-WE1R 315 L8 FAN	IE2-YE1R 315 L8 FAN	132	132.0	110.0	110	110	21	15	8.71	1430	
IE2-WE1R 315 LX8	IE2-YE1R 315 LX8	IE2-WE1R 315 LX8 FAN	IE2-YE1R 315 LX8 FAN	160	160.0	132.0	132	132	21	15	8.71	1430	
IE2-WE2R 355 M8	IE2-YE2R 355 M8	IE2-WE2R 355 M8 FAN	IE2-YE2R 355 M8 FAN	200	200.0	200.0	160	160	40	15	9.5	1850	
IE2-WE2R 355 MX8	IE2-YE2R 355 MX8	IE2-WE2R 355 MX8 FAN	IE2-YE2R 355 MX8 FAN	250	250.0	250.0	200	200	40	15	13.4	2200	
IE2-WE2R 355 L8	IE2-YE2R 355 L8	IE2-WE2R 355 L8 FAN	IE2-YE2R 355 L8 FAN	280	280.0	280.0	250	250	40	15	15.8	2400	

Three-phase motors with squirrel-cage rotor for use in powered smoke and heat extraction systems to EN 12101-3 Energy-saving motor, efficiency class Standard Efficiency IE1

with surface cooling, duty Type S1, continuous duty thermal class H, degree of protection IP 55

				Class		Thermal stress							
				F ₂₀₀ (60)	F ₃₀₀ + F ₂₅₀ (60)	F ₃₀₀	F ₃₀₀	F ₄₀₀					
				1h/200 °C	2h/200 °C + 1h/250 °C	1h/300 °C	2h/300 °C	2h/400 °C					
				VEM code	FV	FV1-1	FV2-1	FV3-1	FV4-4				
Type designation				Rated output					Cooling air				
Cooling IC 411	Cooling IC 411	Cooling IC 418	Cooling IC 418	P _B	P _B	P _B	P _B	P _B	Q	v	J	m	
T-box at D-end	T-box at N-end	T-box at D-end	T-box at N-end	kW	kW	kW	kW	kW	m ³ /min	ms ⁻¹	kgm ²	kg	
Synchronous speed 3000 rpm – 2-pole version													
IE1-K11R 160 M2	IE1-Y11R 160 M2	IE1-K11R 160 M2 FAN	IE1-Y11R 160 M2 FAN	11	7.5	7.5	7.5	5.5	7	19	0.0258	81	
IE1-K11R 160 MX2	IE1-Y11R 160 MX2	IE1-K11R 160 MX2 FAN	IE1-Y11R 160 MX2 FAN	15	11	11	11	7.5	12	19	0.0575	118	
IE1-K11R 160 L2	IE1-Y11R 160 L2	IE1-K11R 160 L2 FAN	IE1-Y11R 160 L2 FAN	18.5	15	15	15	11	12	19	0.0675	134	
IE1-K11R 180 M2	IE1-Y11R 180 M2	IE1-K11R 180 M2 FAN	IE1-Y11R 180 M2 FAN	22	18.5	18.5	18.5	15	14	20	0.105	165	
IE1-K11R 200 L2	IE1-Y11R 200 L2	IE1-K11R 200 L2 FAN	IE1-Y11R 200 L2 FAN	30	22	22	22	18.5	14	21	0.128	195	
IE1-K11R 200 LX2	IE1-Y11R 200 LX2	IE1-K11R 200 LX2 FAN	IE1-Y11R 200 LX2 FAN	37	30	30	30	30	16	21	0.193	255	
IE1-K11R 225 M2	IE1-Y11R 225 M2	IE1-K11R 225 M2 FAN	IE1-Y11R 225 M2 FAN	45	37	37	37	37	16	22	0.22	290	
IE1-K11R 250 M2	IE1-Y11R 250 M2	IE1-K11R 250 M2 FAN	IE1-Y11R 250 M2 FAN	55	45	45	45	45	22	23	0.375	360	
IE1-K11R 280 S2	IE1-Y11R 280 S2	IE1-K11R 280 S2 FAN	IE1-Y11R 280 S2 FAN	75	55	55	55	55	25	23	0.65	490	
IE1-K11R 280 M2	IE1-Y11R 280 M2	IE1-K11R 280 M2 FAN	IE1-Y11R 280 M2 FAN	90	75	75	75	75	25	23	0.675	510	
IE1-K11R 315 S2	IE1-Y11R 315 S2	IE1-K11R 315 S2 FAN	IE1-Y11R 315 S2 FAN	110	90	90	90	90	27	23	1.21	720	
IE1-K11R 315 M2	IE1-Y11R 315 M2	IE1-K11R 315 M2 FAN	IE1-Y11R 315 M2 FAN	132	110	110	110	110	27	23	1.44	800	
IE1-K11R 315 MX2	IE1-Y11R 315 MX2	IE1-K11R 315 MX2 FAN	IE1-Y11R 315 MX2 FAN	160	132	132	132	132	27	23	1.76	980	
IE1-K11R 315 MY2	IE1-Y11R 315 MY2	IE1-K11R 315 MY2 FAN	IE1-Y11R 315 MY2 FAN	200	160	160	160	160	27	23	2.82	1170	
IE1-K11R 315 L2	IE1-Y11R 315 L2	IE1-K11R 315 L2 FAN	IE1-Y11R 315 L2 FAN	250	200	200	200	200	27	23	3.66	1460	
IE1-K11R 315 LX2	IE1-Y11R 315 LX2	IE1-K11R 315 LX2 FAN	IE1-Y11R 315 LX2 FAN	315	250	250	250	250	27	23	4.43	1630	
IE1-K22R 355 M2	IE1-Y22R 355 M2	IE1-K22R 355 M2 FAN	IE1-Y22R 355 M2 FAN	355	300	300	300	300	75	23	4.2	2000	
IE1-K22R 355 MX2	IE1-Y22R 355 MX2	IE1-K22R 355 MX2 FAN	IE1-Y22R 355 MX2 FAN	400	340	340	340	340	75	23	5.5	2200	
IE1-K22R 355 LY2	IE1-Y22R 355 LY2	IE1-K22R 355 LY2 FAN	IE1-Y22R 355 LY2 FAN	450	380	380	380	380	75	23	7.1	2400	
IE1-K22R 355 L2	IE1-Y22R 355 L2	IE1-K22R 355 L2 FAN	IE1-Y22R 355 L2 FAN	500	420	420	420	420	75	23	7.1	2400	
Synchronous speed 1500 rpm – 4-pole version													
IE1-K11R 132 M4	IE1-Y11R 132 M4	IE1-K11R 132 M4 FAN	IE1-Y11R 132 M4 FAN	7.5	5.5	5.5	5.5	4	5.5	12	0.028	70	
IE1-K11R 160 M4	IE1-Y11R 160 M4	IE1-K11R 160 M4 FAN	IE1-Y11R 160 M4 FAN	11	7.5	7.5	7.5	5.5	5.5	12.5	0.035	92	
IE1-K11R 160 L4	IE1-Y11R 160 L4	IE1-K11R 160 L4 FAN	IE1-Y11R 160 L4 FAN	15	11	11	11	7.5	10	12.5	0.078	120	
IE1-K11R 180 M4	IE1-Y11R 180 M4	IE1-K11R 180 M4 FAN	IE1-Y11R 180 M4 FAN	18.5	15	15	15	11	10	13.5	0.09	136	
IE1-K11R 180 L4	IE1-Y11R 180 L4	IE1-K11R 180 L4 FAN	IE1-Y11R 180 L4 FAN	22	18.5	18.5	18.5	15	11	13.5	0.138	170	
IE1-K11R 200 L4	IE1-Y11R 200 L4	IE1-K11R 200 L4 FAN	IE1-Y11R 200 L4 FAN	30	22	22	22	18.5	11	14	0.168	200	
IE1-K11R 225 S4	IE1-Y11R 225 S4	IE1-K11R 225 S4 FAN	IE1-Y11R 225 S4 FAN	37	30	30	30	30	15	14.5	0.275	270	
IE1-K11R 225 M4	IE1-Y11R 225 M4	IE1-K11R 225 M4 FAN	IE1-Y11R 225 M4 FAN	45	37	37	37	37	15	14.5	0.313	300	
IE1-K11R 250 M4	IE1-Y11R 250 M4	IE1-K11R 250 M4 FAN	IE1-Y11R 250 M4 FAN	55	45	45	45	45	21	15	0.525	375	
IE1-K11R 280 S4	IE1-Y11R 280 S4	IE1-K11R 280 S4 FAN	IE1-Y11R 280 S4 FAN	75	55	55	55	55	32	20	0.95	520	
IE1-K11R 280 M4	IE1-Y11R 280 M4	IE1-K11R 280 M4 FAN	IE1-Y11R 280 M4 FAN	90	75	75	75	75	32	20	1.1	580	
IE1-K11R 315 S4	IE1-Y11R 315 S4	IE1-K11R 315 S4 FAN	IE1-Y11R 315 S4 FAN	110	90	90	90	90	45	20	1.96	740	
IE1-K11R 315 M4	IE1-Y11R 315 M4	IE1-K11R 315 M4 FAN	IE1-Y11R 315 M4 FAN	132	110	110	110	110	45	20	2.27	840	
IE1-K11R 315 MX4	IE1-Y11R 315 MX4	IE1-K11R 315 MX4 FAN	IE1-Y11R 315 MX4 FAN	160	132	132	132	132	45	20	2.73	1000	
IE1-K11R 315 MY4	IE1-Y11R 315 MY4	IE1-K11R 315 MY4 FAN	IE1-Y11R 315 MY4 FAN	200	160	160	160	160	45	20	4.82	1200	
IE1-K11R 315 L4	IE1-Y11R 315 L4	IE1-K11R 315 L4 FAN	IE1-Y11R 315 L4 FAN	250	200	200	200	200	45	20	5.93	1510	
IE1-K11R 315 LX4	IE1-Y11R 315 LX4	IE1-K11R 315 LX4 FAN	IE1-Y11R 315 LX4 FAN	315	250	250	250	250	45	20	6.82	1630	
IE1-K22R 355 M4	IE1-Y22R 355 M4	IE1-K22R 355 M4 FAN	IE1-Y22R 355 M4 FAN	355	300	300	300	300	72	20	7.9	2150	
IE1-K22R 355 MX4	IE1-Y22R 355 MX4	IE1-K22R 355 MX4 FAN	IE1-Y22R 355 MX4 FAN	400	340	340	340	340	72	20	9.5	2400	
IE1-K22R 355 LY4	IE1-Y22R 355 LY4	IE1-K22R 355 LY4 FAN	IE1-Y22R 355 LY4 FAN	450	380	380	380	380	81	20	10	2500	
IE1-K22R 355 L4	IE1-Y22R 355 L4	IE1-K22R 355 L4 FAN	IE1-Y22R 355 L4 FAN	500	420	420	420	420	81	20	10	2500	

Three-phase motors with squirrel-cage rotor for use in powered smoke and heat extraction systems to EN 12101-3
Energy-saving motor, efficiency class Standard Efficiency IE1

with surface cooling, duty Type S1, continuous duty thermal class H, degree of protection IP 55

				Class		Thermal stress							
				$F_{200(60)}$	F_{300+} $F_{250(60)}$	F_{300}	F_{300}	F_{300}	F_{400}				
				1h/200 °C	2h/200 °C +1h/250 °C	1h/300 °C	2h/300 °C	2h/300 °C	2h/400 °C				
				VEM code	FV	FV1-1	FV2-1	FV3-1	FV4-4				
Type designation				Rated output					Cooling air				
Cooling IC 411	Cooling IC 411	Cooling IC 418	Cooling IC 418	P_B	P_B	P_B	P_B	P_B	Q	v	J	m	
T-box at D-end	T-box at N-end	T-box at D-end	T-box at N-end	kW	kW	kW	kW	kW	m ³ /min	ms ⁻¹	kgm ²	kg	
Synchronous speed 1000 rpm – 6-pole version													
IE1-K11R 132 MX6	IE1-Y11R 132 MX6	IE1-K11R 132 MX6 FAN	IE1-Y11R 132 MX6 FAN	5.5	4	4	4	3	4	9.5	0.043	70	
IE1-K11R 160 M6	IE1-Y11R 160 M6	IE1-K11R 160 M6 FAN	IE1-Y11R 160 M6 FAN	7.5	5.5	5.5	5.5	4	4	10.5	0.053	86	
IE1-K11R 160 L6	IE1-Y11R 160 L6	IE1-K11R 160 L6 FAN	IE1-Y11R 160 L6 FAN	11	7.5	7.5	7.5	5.5	5	10.5	0.113	114	
IE1-K11R 180 L6	IE1-Y11R 180 L6	IE1-K11R 180 L6 FAN	IE1-Y11R 180 L6 FAN	15	11	11	11	7.5	5	11	0.145	136	
IE1-K11R 200 L6	IE1-Y11R 200 L6	IE1-K11R 200 L6 FAN	IE1-Y11R 200 L6 FAN	18.5	15	15	15	11	8	11.5	0.228	175	
IE1-K11R 200 LX6	IE1-Y11R 200 LX6	IE1-K11R 200 LX6 FAN	IE1-Y11R 200 LX6 FAN	22	18.5	18.5	18.5	15	8	11.5	0.268	200	
IE1-K11R 225 M6	IE1-Y11R 225 M6	IE1-K11R 225 M6 FAN	IE1-Y11R 225 M6 FAN	30	22	22	22	22	10	12	0.443	265	
IE1-K11R 250 M6	IE1-Y11R 250 M6	IE1-K11R 250 M6 FAN	IE1-Y11R 250 M6 FAN	37	30	30	30	30	14	12.5	0.825	360	
IE1-K11R 280 S6	IE1-Y11R 280 S6	IE1-K11R 280 S6 FAN	IE1-Y11R 280 S6 FAN	45	37	37	37	37	21	15	1.28	465	
IE1-K11R 280 M6	IE1-Y11R 280 M6	IE1-K11R 280 M6 FAN	IE1-Y11R 280 M6 FAN	55	45	45	45	45	21	15	1.48	520	
IE1-K11R 315 S6	IE1-Y11R 315 S6	IE1-K11R 315 S6 FAN	IE1-Y11R 315 S6 FAN	75	55	55	55	55	30	20	2.63	690	
IE1-K11R 315 M6	IE1-Y11R 315 M6	IE1-K11R 315 M6 FAN	IE1-Y11R 315 M6 FAN	90	75	75	75	75	30	20	3.33	800	
IE1-K11R 315 MX6	IE1-Y11R 315 MX6	IE1-K11R 315 MX6 FAN	IE1-Y11R 315 MX6 FAN	110	90	90	90	90	30	20	3.6	880	
IE1-K11R 315 MY6	IE1-Y11R 315 MY6	IE1-K11R 315 MY6 FAN	IE1-Y11R 315 MY6 FAN	132	110	110	110	110	30	20	6	1050	
IE1-K11R 315 L6	IE1-Y11R 315 L6	IE1-K11R 315 L6 FAN	IE1-Y11R 315 L6 FAN	160	132	132	132	132	30	20	6.67	1250	
IE1-K11R 315 LX6	IE1-Y11R 315 LX6	IE1-K11R 315 LX6 FAN	IE1-Y11R 315 LX6 FAN	200	160	160	160	160	30	20	8.6	1460	
IE1-K22R 355 M6	IE1-Y22R 355 M6	IE1-K22R 355 M6 FAN	IE1-Y22R 355 M6 FAN	250	200	200	200	200	54	20	8.2	1650	
IE1-K22R 355 MX6	IE1-Y22R 355 MX6	IE1-K22R 355 MX6 FAN	IE1-Y22R 355 MX6 FAN	315	250	250	250	250	54	20	12.1	2200	
IE1-K22R 355 LY6	IE1-Y22R 355 LY6	IE1-K22R 355 LY6 FAN	IE1-Y22R 355 LY6 FAN	355	300	300	300	300	54	20	14	2400	
Synchronous speed 750 rpm – 8-pole version													
IE1-K11R 160 M8	IE1-Y11R 160 M8	IE1-K11R 160 M8 FAN	IE1-Y11R 160 M8 FAN	4	3	3	3	2.2	3	8.5	0.043	70	
IE1-K11R 160 MX8	IE1-Y11R 160 MX8	IE1-K11R 160 MX8 FAN	IE1-Y11R 160 MX8 FAN	5.5	4	4	4	3	3	8.5	0.053	86	
IE1-K11R 160 L8	IE1-Y11R 160 L8	IE1-K11R 160 L8 FAN	IE1-Y11R 160 L8 FAN	7.5	5.5	5.5	5.5	4	4	8.5	0.113	114	
IE1-K11R 180 L8	IE1-Y11R 180 L8	IE1-K11R 180 L8 FAN	IE1-Y11R 180 L8 FAN	11	7.5	7.5	7.5	5.5	4	9	0.145	136	
IE1-K11R 200 L8	IE1-Y11R 200 L8	IE1-K11R 200 L8 FAN	IE1-Y11R 200 L8 FAN	15	11	11	11	7.5	6	9.5	0.228	175	
IE1-K11R 225 S8	IE1-Y11R 225 S8	IE1-K11R 225 S8 FAN	IE1-Y11R 225 S8 FAN	18.5	18.5	18.5	18.5	18.5	8	10	0.44	265	
IE1-K11R 225 M8	IE1-Y11R 225 M8	IE1-K11R 225 M8 FAN	IE1-Y11R 225 M8 FAN	22	18.5	18.5	18.5	18.5	11	10	0.44	265	
IE1-K11R 250 M8	IE1-Y11R 250 M8	IE1-K11R 250 M8 FAN	IE1-Y11R 250 M8 FAN	30	22	22	22	22	16	10.5	0.825	360	
IE1-K11R 280 S8	IE1-Y11R 280 S8	IE1-K11R 280 S8 FAN	IE1-Y11R 280 S8 FAN	37	30	30	30	30	16	15	1.35	465	
IE1-K11R 280 M8	IE1-Y11R 280 M8	IE1-K11R 280 M8 FAN	IE1-Y11R 280 M8 FAN	45	37	37	37	37	16	15	1.55	520	
IE1-K11R 315 S8	IE1-Y11R 315 S8	IE1-K11R 315 S8 FAN	IE1-Y11R 315 S8 FAN	55	45	45	45	45	21	15	2.63	690	
IE1-K11R 315 M8	IE1-Y11R 315 M8	IE1-K11R 315 M8 FAN	IE1-Y11R 315 M8 FAN	75	55	55	55	55	21	15	3.33	800	
IE1-K11R 315 MX8	IE1-Y11R 315 MX8	IE1-K11R 315 MX8 FAN	IE1-Y11R 315 MX8 FAN	90	75	75	75	75	21	15	3.6	880	
IE1-K11R 315 MY8	IE1-Y11R 315 MY8	IE1-K11R 315 MY8 FAN	IE1-Y11R 315 MY8 FAN	110	90	90	90	90	21	15	6	1050	
IE1-K11R 315 L8	IE1-Y11R 315 L8	IE1-K11R 315 L8 FAN	IE1-Y11R 315 L8 FAN	132	110	110	110	110	21	15	6.76	1250	
IE1-K11R 315 LX8	IE1-Y11R 315 LX8	IE1-K11R 315 LX8 FAN	IE1-Y11R 315 LX8 FAN	160	132	132	132	132	21	15	8.71	1430	
IE1-K22R 355 M8	IE1-Y22R 355 M8	IE1-K22R 355 M8 FAN	IE1-Y22R 355 M8 FAN	200	160	160	160	160	40	15	9.5	1600	
IE1-K22R 355 MX8	IE1-Y22R 355 MX8	IE1-K22R 355 MX8 FAN	IE1-Y22R 355 MX8 FAN	250	200	200	200	200	40	15	13.4	2200	
IE1-K22R 355 LY8	IE1-Y22R 355 LY8	IE1-K22R 355 LY8 FAN	IE1-Y22R 355 LY8 FAN	280	230	230	230	230	40	15	15.8	2400	

Three-phase motors with squirrel-cage rotor for use in powered smoke and heat extraction systems to EN 12101-3

Energy-saving motor, efficiency class Standard Efficiency IE1

with surface cooling, duty Type S1, continuous duty thermal class H, degree of protection IP 55

				Class		Thermal stress		VEM code					
				$F_{200}(60)$	$F_{200} + F_{250}(60)$	1h/200 °C	2h/200 °C + 1h/250 °C	F_{300}	F_{300}	F_{300}	F_{300}	F_{400}	F_{400}
				FV	FV1-1	FV2-1	FV3-1	FV4-4					
Type designation				Rated output					Cooling air				
Cooling IC 411	Cooling IC 411	Cooling IC 418	Cooling IC 418	P_B	P_B	P_B	P_B	P_B	Q	v	J	m	
T-box at D-end	T-box at N-end	T-box at D-end	T-box at N-end	kW	kW	kW	kW	kW	m ³ /min	ms ⁻¹	kgm ²	kg	
Synchronous speed 3000 rpm – 2-pole version													
IE1-K10R 132 M2	IE1-Y10R 132 M2	IE1-K10R 132 M2 FAN	IE1-Y10R 132 M2 FAN	11	7.5	7.5	7.5	5.5	7	19	0.0258	81	
IE1-K10R 160 S2	IE1-Y10R 160 S2	IE1-K10R 160 S2 FAN	IE1-Y10R 160 S2 FAN	15	11	11	11	7.5	12	19	0.0575	118	
IE1-K10R 160 M2	IE1-Y10R 160 M2	IE1-K10R 160 M2 FAN	IE1-Y10R 160 M2 FAN	18.5	15	15	15	11	12	19	0.0675	134	
IE1-K10R 180 S2	IE1-Y10R 180 S2	IE1-K10R 180 S2 FAN	IE1-Y10R 180 S2 FAN	22	18.5	18.5	18.5	15	14	20	0.105	165	
IE1-K10R 180 M2	IE1-Y10R 180 M2	IE1-K10R 180 M2 FAN	IE1-Y10R 180 M2 FAN	30	22	22	22	18.5	14	21	0.128	195	
IE1-K10R 200 M2	IE1-Y10R 200 M2	IE1-K10R 200 M2 FAN	IE1-Y10R 200 M2 FAN	37	30	30	30	30	16	21	0.193	255	
IE1-K10R 200 L2	IE1-Y10R 200 L2	IE1-K10R 200 L2 FAN	IE1-Y10R 200 L2 FAN	45	37	37	37	37	16	22	0.22	290	
IE1-K10R 225 M2	IE1-Y10R 225 M2	IE1-K10R 225 M2 FAN	IE1-Y10R 225 M2 FAN	55	45	45	45	45	22	23	0.375	360	
IE1-K10R 250 S2	IE1-Y10R 250 S2	IE1-K10R 250 S2 FAN	IE1-Y10R 250 S2 FAN	75	55	55	55	55	25	23	0.65	490	
IE1-K10R 250 M2	IE1-Y10R 250 M2	IE1-K10R 250 M2 FAN	IE1-Y10R 250 M2 FAN	90	75	75	75	75	25	23	0.675	510	
IE1-K10R 280 S2	IE1-Y10R 280 S2	IE1-K10R 280 S2 FAN	IE1-Y10R 280 S2 FAN	110	90	90	90	90	27	23	1.21	720	
IE1-K10R 280 M2	IE1-Y10R 280 M2	IE1-K10R 280 M2 FAN	IE1-Y10R 280 M2 FAN	132	110	110	110	110	27	23	1.44	800	
IE1-K10R 315 S2	IE1-Y10R 315 S2	IE1-K10R 315 S2 FAN	IE1-Y10R 315 S2 FAN	160	132	132	132	132	27	23	1.76	980	
IE1-K10R 315 M2	IE1-Y10R 315 M2	IE1-K10R 315 M2 FAN	IE1-Y10R 315 M2 FAN	200	160	160	160	160	27	23	2.82	1170	
IE1-K10R 315 L2	IE1-Y10R 315 L2	IE1-K10R 315 L2 FAN	IE1-Y10R 315 L2 FAN	250	200	200	200	200	27	23	3.66	1460	
IE1-K10R 315 LX2	IE1-Y10R 315 LX2	IE1-K10R 315 LX2 FAN	IE1-Y10R 315 LX2 FAN	315	250	250	250	250	27	23	4.43	1630	
Synchronous speed 1500 rpm – 4-pole version													
IE1-K10R 132 S4	IE1-Y10R 132 S4	IE1-K10R 132 S4 FAN	IE1-Y10R 132 S4 FAN	7.5	5.5	5.5	5.5	4	5.5	12	0.028	70	
IE1-K10R 132 M4	IE1-Y10R 132 M4	IE1-K10R 132 M4 FAN	IE1-Y10R 132 M4 FAN	11	7.5	7.5	7.5	5.5	5.5	12.5	0.035	92	
IE1-K10R 160 S4	IE1-Y10R 160 S4	IE1-K10R 160 S4 FAN	IE1-Y10R 160 S4 FAN	15	11	11	11	7.5	10	12.5	0.078	120	
IE1-K10R 160 M4	IE1-Y10R 160 M4	IE1-K10R 160 M4 FAN	IE1-Y10R 160 M4 FAN	18.5	15	15	15	11	10	13.5	0.09	136	
IE1-K10R 180 S4	IE1-Y10R 180 S4	IE1-K10R 180 S4 FAN	IE1-Y10R 180 S4 FAN	22	18.5	18.5	18.5	15	11	13.5	0.138	170	
IE1-K10R 180 M4	IE1-Y10R 180 M4	IE1-K10R 180 M4 FAN	IE1-Y10R 180 M4 FAN	30	22	22	22	18.5	11	14	0.168	200	
IE1-K10R 200 M4	IE1-Y10R 200 M4	IE1-K10R 200 M4 FAN	IE1-Y10R 200 M4 FAN	37	30	30	30	30	15	14.5	0.275	270	
IE1-K10R 200 L4	IE1-Y10R 200 L4	IE1-K10R 200 L4 FAN	IE1-Y10R 200 L4 FAN	45	37	37	37	37	15	14.5	0.313	300	
IE1-K10R 225 M4	IE1-Y10R 225 M4	IE1-K10R 225 M4 FAN	IE1-Y10R 225 M4 FAN	55	45	45	45	45	21	15	0.525	375	
IE1-K10R 250 S4	IE1-Y10R 250 S4	IE1-K10R 250 S4 FAN	IE1-Y10R 250 S4 FAN	75	55	55	55	55	32	20	0.95	520	
IE1-K10R 250 M4	IE1-Y10R 250 M4	IE1-K10R 250 M4 FAN	IE1-Y10R 250 M4 FAN	90	75	75	75	75	32	20	1.1	580	
IE1-K10R 280 S4	IE1-Y10R 280 S4	IE1-K10R 280 S4 FAN	IE1-Y10R 280 S4 FAN	110	90	90	90	90	45	20	1.96	740	
IE1-K10R 280 M4	IE1-Y10R 280 M4	IE1-K10R 280 M4 FAN	IE1-Y10R 280 M4 FAN	132	110	110	110	110	45	20	2.27	840	
IE1-K10R 315 S4	IE1-Y10R 315 S4	IE1-K10R 315 S4 FAN	IE1-Y10R 315 S4 FAN	160	132	132	132	132	45	20	2.73	1000	
IE1-K10R 315 M4	IE1-Y10R 315 M4	IE1-K10R 315 M4 FAN	IE1-Y10R 315 M4 FAN	200	160	160	160	160	45	20	4.82	1200	
IE1-K10R 315 L4	IE1-Y10R 315 L4	IE1-K10R 315 L4 FAN	IE1-Y10R 315 L4 FAN	250	200	200	200	200	45	20	5.93	1510	
IE1-K10R 315 LX4	IE1-Y10R 315 LX4	IE1-K10R 315 LX4 FAN	IE1-Y10R 315 LX4 FAN	315	250	250	250	250	45	20	6.82	1630	

Three-phase motors with squirrel-cage rotor for use in powered smoke and heat extraction systems to EN 12101-3
Energy-saving motor, efficiency class Standard Efficiency IE1

with surface cooling, duty Type S1, continuous duty thermal class H, degree of protection IP 55

				Class		Thermal stress		VEM code						
				$F_{200(60)}$	F_{300+} $F_{250(60)}$	1h/200 °C	2h/200 °C +1h/250 °C	1h/300 °C	2h/300 °C	2h/400 °C				
				FV	FV1-1	FV2-1	FV3-1	FV4-4						
Type designation				Rated output					Cooling air					
Cooling IC 411	Cooling IC 411	Cooling IC 418	Cooling IC 418	P_B	P_B	P_B	P_B	P_B	Q	v	J	m		
T-box at D-end	T-box at N-end	T-box at D-end	T-box at N-end	kW	kW	kW	kW	kW	m ³ /min	ms ⁻¹	kgm ²	kg		
Synchronous speed 1000 rpm – 6-pole version														
IE1-K10R 132 S6	IE1-Y10R 132 S6	IE1-K10R 132 S6 FAN	IE1-Y10R 132 S6 FAN	5.5	4	4	4	3	4	9.5	0.043	70		
IE1-K10R 132 M6	IE1-Y10R 132 M6	IE1-K10R 132 M6 FAN	IE1-Y10R 132 M6 FAN	7.5	5.5	5.5	5.5	4	4	10.5	0.053	86		
IE1-K10R 160 S6	IE1-Y10R 160 S6	IE1-K10R 160 S6 FAN	IE1-Y10R 160 S6 FAN	11	7.5	7.5	7.5	5.5	5	10.5	0.113	114		
IE1-K10R 160 M6	IE1-Y10R 160 M6	IE1-K10R 160 M6 FAN	IE1-Y10R 160 M6 FAN	15	11	11	11	7.5	5	11	0.145	136		
IE1-K10R 180 S6	IE1-Y10R 180 S6	IE1-K10R 180 S6 FAN	IE1-Y10R 180 S6 FAN	18.5	15	15	15	11	8	11.5	0.228	175		
IE1-K10R 180 M6	IE1-Y10R 180 M6	IE1-K10R 180 M6 FAN	IE1-Y10R 180 M6 FAN	22	18.5	18.5	18.5	15	8	11.5	0.268	200		
IE1-K10R 200 M6	IE1-Y10R 200 M6	IE1-K10R 200 M6 FAN	IE1-Y10R 200 M6 FAN	30	22	22	22	22	10	12	0.443	265		
IE1-K10R 225 M6	IE1-Y10R 225 M6	IE1-K10R 225 M6 FAN	IE1-Y10R 225 M6 FAN	37	30	30	30	30	14	12.5	0.825	360		
IE1-K10R 250 S6	IE1-Y10R 250 S6	IE1-K10R 250 S6 FAN	IE1-Y10R 250 S6 FAN	45	37	37	37	37	21	15	1.28	465		
IE1-K10R 250 M6	IE1-Y10R 250 M6	IE1-K10R 250 M6 FAN	IE1-Y10R 250 M6 FAN	55	45	45	45	45	21	15	1.48	520		
IE1-K10R 280 S6	IE1-Y10R 280 S6	IE1-K10R 280 S6 FAN	IE1-Y10R 280 S6 FAN	75	55	55	55	55	30	20	2.63	690		
IE1-K10R 280 M6	IE1-Y10R 280 M6	IE1-K10R 280 M6 FAN	IE1-Y10R 280 M6 FAN	90	75	75	75	75	30	20	3.33	800		
IE1-K10R 315 S6	IE1-Y10R 315 S6	IE1-K10R 315 S6 FAN	IE1-Y10R 315 S6 FAN	110	90	90	90	90	30	20	3.6	880		
IE1-K10R 315 M6	IE1-Y10R 315 M6	IE1-K10R 315 M6 FAN	IE1-Y10R 315 M6 FAN	132	110	110	110	110	30	20	6	1050		
IE1-K10R 315 L6	IE1-Y10R 315 L6	IE1-K10R 315 L6 FAN	IE1-Y10R 315 L6 FAN	160	132	132	132	132	30	20	6.67	1250		
IE1-K10R 315 LX6	IE1-Y10R 315 LX6	IE1-K10R 315 LX6 FAN	IE1-Y10R 315 LX6 FAN	200	160	160	160	160	30	20	8.6	1460		
Synchronous speed 750 rpm – 8-pole version														
IE1-K10R 132 S8	IE1-Y10R 132 S8	IE1-K10R 132 S8 FAN	IE1-Y10R 132 S8 FAN	4	3	3	3	2.2	3	8.5	0.043	70		
IE1-K10R 132 M8	IE1-Y10R 132 M8	IE1-K10R 132 M8 FAN	IE1-Y10R 132 M8 FAN	5.5	4	4	4	3	3	8.5	0.053	86		
IE1-K10R 160 S8	IE1-Y10R 160 S8	IE1-K10R 160 S8 FAN	IE1-Y10R 160 S8 FAN	7.5	5.5	5.5	5.5	4	4	8.5	0.113	114		
IE1-K10R 160 M8	IE1-Y10R 160 M8	IE1-K10R 160 M8 FAN	IE1-Y10R 160 M8 FAN	11	7.5	7.5	7.5	5.5	4	9	0.145	136		
IE1-K10R 180 S8	IE1-Y10R 180 S8	IE1-K10R 180 S8 FAN	IE1-Y10R 180 S8 FAN	15	11	11	11	7.5	6	9.5	0.228	175		
IE1-K10R 180 M8	IE1-Y10R 180 M8	IE1-K10R 180 M8 FAN	IE1-Y10R 180 M8 FAN	18.5	15	15	15	11	8	9.5	0.268	200		
IE1-K10R 200 M8	IE1-Y10R 200 M8	IE1-K10R 200 M8 FAN	IE1-Y10R 200 M8 FAN	22	18.5	18.5	18.5	18.5	11	10	0.44	265		
IE1-K10R 225 M8	IE1-Y10R 225 M8	IE1-K10R 225 M8 FAN	IE1-Y10R 225 M8 FAN	30	22	22	22	22	16	10.5	0.825	360		
IE1-K10R 250 S8	IE1-Y10R 250 S8	IE1-K10R 250 S8 FAN	IE1-Y10R 250 S8 FAN	37	30	30	30	30	16	15	1.35	465		
IE1-K10R 250 M8	IE1-Y10R 250 M8	IE1-K10R 250 M8 FAN	IE1-Y10R 250 M8 FAN	45	37	37	37	37	16	15	1.55	520		
IE1-K10R 280 S8	IE1-Y10R 280 S8	IE1-K10R 280 S8 FAN	IE1-Y10R 280 S8 FAN	55	45	45	45	45	21	15	2.63	690		
IE1-K10R 280 M8	IE1-Y10R 280 M8	IE1-K10R 280 M8 FAN	IE1-Y10R 280 M8 FAN	75	55	55	55	55	21	15	3.33	800		
IE1-K10R 315 S8	IE1-Y10R 315 S8	IE1-K10R 315 S8 FAN	IE1-Y10R 315 S8 FAN	90	75	75	75	75	21	15	3.6	880		
IE1-K10R 315 M8	IE1-Y10R 315 M8	IE1-K10R 315 M8 FAN	IE1-Y10R 315 M8 FAN	110	90	90	90	90	21	15	6	1050		
IE1-K10R 315 L8	IE1-Y10R 315 L8	IE1-K10R 315 L8 FAN	IE1-Y10R 315 L8 FAN	132	110	110	110	110	21	15	6.76	1250		
IE1-K10R 315 LX8	IE1-Y10R 315 LX8	IE1-K10R 315 LX8 FAN	IE1-Y10R 315 LX8 FAN	160	132	132	132	132	21	15	8.71	1430		

Bearings

Energy-saving motors IE3-W41R

Type	Anti-friction bearing	D-end				Anti-friction bearing	N-end		Figure		
		V-ring	γ-ring	Wave spring	Disc spring		V-ring	γ-ring	N-end	D-end	Fixed bearing
IE3-W41R 112 M2	6207 ZZ C3	-	RB35	72	-	6207 ZZ C3	-	RB35	6	8	N-end
IE3-W41R 112 M4	6207 ZZ C3	-	RB35	72	-	6207 ZZ C3	-	RB35	6	8	N-end
IE3-W41R 132 S2	6208 ZZ C3	-	RB40	80	-	6207 ZZ C3	-	RB35	6	8	N-end
IE3-W41R 132 SX2	6308 ZZ C3	-	RB40	90	-	6308 ZZ C3	-	RB40	6	8	N-end
IE3-W41R 132 S4	6308 ZZ C3	-	RB40	90	-	6308 ZZ C3	-	RB40	6	8	N-end
IE3-W41R 132 M4	6308 ZZ C3	-	RB40	90	-	6308 ZZ C3	-	RB40	6	8	N-end
IE3-W41R 160 M2	6310 ZZ C3	-	RB50	110	-	6309 ZZ C3	-	RB45	6	8	N-end
IE3-W41R 160 MX2	6310 ZZ C3	-	RB50	110	-	6309 ZZ C3	-	RB45	6	8	N-end
IE3-W41R 160 L2	6310 ZZ C3	-	RB50	110	-	6309 ZZ C3	-	RB45	6	8	N-end
IE3-W41R 160 M4	6310 ZZ C3	-	RB50	110	-	6309 ZZ C3	-	RB45	6	8	N-end
IE3-W41R 160 L4C	6310 ZZ C3	-	RB50	110	-	6309 ZZ C3	-	RB45	6	8	N-end
IE3-W41R 180 M2C	6310 C3	50A	-	110	-	6310 C3	50A	-	6	8	N-end
IE3-W41R 200 L2	6312 C3	60A	-	-	130	6312 C3	60A	-	6	8	N-end
IE3-W41R 200 LX2C	6312 C3	60A	-	-	130	6312 C3	60A	-	6	8	N-end
IE3-W41R 225 M2	6313 C3	65A	-	-	140	6313 C3	65A	-	6	8	N-end
IE3-W41R 250 M2	6314 C3	70A	-	-	150	6314 C3	70A	-	6	8	N-end
IE3-W41R 180 M4	6310 C3	50A	-	110	-	6310 C3	50A	-	6	8	N-end
IE3-W41R 180 L4	6310 C3	50A	-	110	-	6310 C3	50A	-	6	8	N-end
IE3-W41R 200 L4C	6312 C3	60A	-	-	130	6312 C3	60A	-	6	8	N-end
IE3-W41R 225 S4C	6313 C3	65A	-	-	140	6312 C3	60A	-	6	8	N-end
IE3-W41R 225 M4	6314 C3	70A	-	-	150	6313 C3	65A	-	6	8	N-end
IE3-W41R 250 M4	6316 C3	80A	-	-	170	6314 C3	70A	-	6	8	N-end
IE3-W41R 132 S6	6208 ZZ C3	-	RB40	80	-	6207 ZZ C3	-	RB35	6	8	N-end
IE3-W41R 132 M6	6308 ZZ C3	-	RB40	90	-	6308 ZZ C3	-	RB40	6	8	N-end
IE3-W41R 132 MX6	6308 ZZ C3	-	RB40	90	-	6308 ZZ C3	-	RB40	6	8	N-end
IE3-W41R 160 M6	6310 ZZ C3	-	RB50	110	-	6309 ZZ C3	-	RB45	6	8	N-end
IE3-W41R 160 L6C	6310 ZZ C3	-	RB50	110	-	6309 ZZ C3	-	RB45	6	8	N-end
IE3-W41R 180 L6C	6310 C3	50A	-	110	-	6310 C3	50A	-	6	8	N-end
IE3-W41R 200 L6	6312 C3	60A	-	-	130	6312 C3	60A	-	6	8	N-end
IE3-W41R 200 LX6C	6312 C3	60A	-	-	130	6312 C3	60A	-	6	8	N-end
IE3-W41R 225 M6	6314 C3	70A	-	-	150	6313 C3	65A	-	6	8	N-end
IE3-W41R 250 M6	6316 C3	80A	-	-	170	6314 C3	70A	-	6	8	N-end
IE3-W41R 280 S2	6314 C3	70A	-	-	150	6314 C3	70A	-	6	8	N-end
IE3-W41R 280 M2	6314 C3	70A	-	-	150	6314 C3	70A	-	6	8	N-end
IE3-W41R 280 S4	6316 C3	80A	-	-	170	6314 C3	70A	-	6	8	N-end
IE3-W41R 280 M4	6317 C3	85A	-	-	180	6316 C3	80A	-	6	8	N-end
IE3-W41R 280 S6, M6	6317 C3	85A	-	-	180	6316 C3	80A	-	6	8	N-end
IE3-W41R 315 S2, M2	6316 C3	80A	-	-	170	6316 C3	80A	-	6	8	N-end
IE3-W41R 315 MX2	6317 C3	85A	-	-	180	6317 C3 ¹⁾	85A	-	6	8	N-end
IE3-W41R 315 MY2, L2, LX2	6317 C3	85A	-	-	180	6317 C3 ¹⁾	85A	-	6	8	N-end
IE3-W41R 315 S4, M4	6317 C3	85A	-	-	180	6316 C3	80A	-	6	8	N-end
IE3-W41R 315 MX4	6320 C3	-	RB100	-	215	6317 C3 ¹⁾	85A	-	18	19	N-end
IE3-W41R 315 MY4	6320 C3	-	RB100	-	215	6317 C3 ¹⁾	85A	-	18	19	N-end
IE3-W41R 315 L4, LX4	6320 C3	-	RB100	-	215	6317 C3 ¹⁾	85A	-	18	19	N-end
IE3-W41R 315 S6	6320 C3	-	RB100	-	215	6317 C3 ¹⁾	85A	-	18	19	N-end
IE3-W41R 315 M6, MX6, MY6	6320 C3	-	RB100	-	215	6317 C3 ¹⁾	85A	-	18	19	N-end
IE3-W41R 355 M2	6317 C3	-	RB85A	-	180	6317 C3 ¹⁾	85A	-	18	19	N-end
IE3-W41R 355 M4, 6	6324 C3	-	RB120	-	260	6317 C3 ¹⁾	85A	-	18	19	N-end

¹⁾ For types for vertical mounting Q317 C3; figures 18, 21

IE3-W41R from 2-pole 315 MX, 4-pole 315 MX, 6-pole 315S with relubrication device as standard

Bearings corresponding to fire-gas classes FV, FV1, FV2 and FV3

For fire-gas class FV4, only bearings with a solid brass cage are used

Size 400 upon request

Energy-saving motors IE3-W41R

Type	D-end				N-end				Figure		Fixed bearing
	Anti-friction bearing				Anti-friction bearing				N-end	D-end	
		V-ring	γ-ring	Wave spring	Disc spring		V-ring	γ-ring			
IE3-W41R 132 S8	6308 ZZ C3	-	RB40	90	-	6308 ZZ C3	-	RB40	6	8	N-end
IE3-W41R 132 M8	6308 ZZ C3	-	RB40	90	-	6308 ZZ C3	-	RB40	6	8	N-end
IE3-W41R 160 M8	6310 ZZ C3	-	RB50	110	-	6309 ZZ C3	-	RB45	6	8	N-end
IE3-W41R 160 MX8	6310 ZZ C3	-	RB50	110	-	6309 ZZ C3	-	RB45	6	8	N-end
IE3-W41R 160 L8	6310 ZZ C3	-	RB50	110	-	6309 ZZ C3	-	RB45	6	8	N-end
IE3-W41R 180 L8	6310 C3	50A	-	110	-	6310 C3	50A	-	6	8	N-end
IE3-W41R 200 L8	6310 C3	50A	-	110	-	6310 C3	50A	-	6	8	N-end
IE3-W41R 225 S8	6312 C3	60A	-	-	130	6312 C3	60A	-	6	8	N-end
IE3-W41R 225 M8	6314 C3	70A	-	-	150	6313 C3	65A	-	6	8	N-end
IE3-W41R 250 M8	6314 C3	70A	-	-	150	6313 C3	65A	-	6	8	N-end
IE3-W41R 280 S8	6316 C3	80A	-	-	170	6314 C3	70A	-	6	8	N-end
IE3-W41R 280 M8	6317 C3	85A	-	-	180	6316 C3	80A	-	6	8	N-end
IE3-W41R 315 S8	6317 C3	85A	-	-	180	6316 C3	80A	-	18	19	N-end
IE3-W41R 315 M8, MX8, MY8,L8	6320 C3	-	RB100	-	215	6317 C3 ¹⁾	85A	-	18	19	N-end
IE3-W41R 355 M8	6324 C3	-	RB120	-	260	6317 C3 ¹⁾	85A	-	18	19	N-end

¹⁾ For types for vertical mounting Q317 C3; figures 18, 21
 IE3-W41R from 315 M with relubrication device as standard
 Bearings corresponding to fire-gas classes FV, FV1, FV2 and FV3
 For fire-gas class FV4, only bearings with a solid brass cage are used

Energy-saving motors IE3-W41R
 Relubrication device

Type	D-end					N-end		Figure				Fixed bearing	
	Anti-friction bearing					Anti-friction bearing		D-end	N-end	D-end	N-end		
	Light-duty Bearings	Reinforced Bearings	γ-ring	Wave spring ¹⁾	Disc spring ¹⁾	V-ring	γ-ring	Light-duty Bearings	Light-duty Bearings	Reinforced Bearings	Reinforced Bearings		
IE3-W41R 132 S8	6308 C3	NU 308	RB40	90	-	6308 C3	RB40	13	14	15	14	N-end	
IE3-W41R 132 M8	6308 C3	NU 308	RB40	90	-	6308 C3	RB40	13	14	15	14	N-end	
IE3-W41R 160 M8	6310 C3	NU 310 E	RB50	110	-	6309 C3	-	RB45	13	14	15	14	N-end
IE3-W41R 160 MX8	6310 C3	NU 310 E	RB50	110	-	6309 C3	-	RB45	13	14	15	14	N-end
IE3-W41R 160 L8	6310 C3	NU 310 E	RB50	110	-	6309 C3	-	RB45	13	14	15	14	N-end
IE3-W41R 180 L8	6310 C3	NU 310 E	RB50	110	-	6310 C3	50A	-	13	14	15	14	N-end
IE3-W41R 200 L8	6310 C3	NU 310 E	RB50	110	-	6310 C3	50A	-	13	14	15	14	N-end
IE3-W41R 225 S8	6312 C3	NU 312 E	RB60	-	130	6312 C3	60A	-	13	14	15	14	N-end
IE3-W41R 225 M8	6314 C3	NU 314 E	RB70	-	150	6313 C3	65A	-	13	14	15	14	N-end
IE3-W41R 250 M8	6314 C3	NU 314 E	RB70	-	150	6313 C3	65A	-	13	14	15	14	N-end
IE3-W41R 280 S8	6316 C3	NU 316 E	RB80	-	170	6314 C3	70A	-	13	14	15	14	N-end
IE3-W41R 280 M8	6317 C3	NU 317 E	RB85	-	180	6316 C3	80A	-	13	14	15	14	N-end
IE3-W41R 315 S8	6317 C3	NU 317 E	RB85	-	180	6316 C3	80A	-	13	14	15	14	N-end
IE3-W41R 315 M8, MX8, MY8,L8													
IE3-W41R 355 M8													

¹⁾ Light-duty bearings only
 Bearings corresponding to fire-gas classes FV, FV1, FV2 and FV3
 For fire-gas class FV4, only bearings with a solid brass cage are used

Energy-saving motors IE3-W41R Relubrication device

Type	D-end					N-end		Figure					Fixed bearing
	Anti-friction bearing					Anti-friction bearing		D-end	N-end	D-end	N-end		
	Light-duty Bearings	Reinforced Bearings	γ-ring	Wave spring ¹⁾	Disc spring ¹⁾	V-ring	γ-ring	Light-duty Bearings	Light-duty Bearings	Reinforced Bearings	Reinforced Bearings		
IE3-W41R 132 S2	not possible at D-end for design reasons												
IE3-W41R 132 SX2	6308 C3	NU 308	RB40	90	-	6308 C3	RB40	13	14	15	14	N-end	
IE3-W41R 132 S4	6308 C3	NU 308	RB40	90	-	6308 C3	RB40	13	14	15	14	N-end	
IE3-W41R 132 M4	6308 C3	NU 308	RB40	90	-	6308 C3	RB40	13	14	15	14	N-end	
IE3-W41R 160 M2	6310 C3	NU 310 E	RB50	110	-	6309 C3	- RB45	13	14	15	14	N-end	
IE3-W41R 160 MX2	6310 C3	NU 310 E	RB50	110	-	6309 C3	- RB45	13	14	15	14	N-end	
IE3-W41R 160 L2	6310 C3	NU 310 E	RB50	110	-	6309 C3	- RB45	13	14	15	14	N-end	
IE3-W41R 160 M4	6310 C3	NU 310 E	RB50	110	-	6309 C3	- RB45	13	14	15	14	N-end	
IE3-W41R 160 L4C	6310 C3	NU 310 E	RB50	110	-	6309 C3	- RB45	13	14	15	14	N-end	
IE3-W41R 180 M2C	6310 C3	NU 310 E	RB50	110	-	6310 C3	50A -	13	14	15	14	N-end	
IE3-W41R 200 L2	6312 C3	NU 312 E	RB60	-	130	6312 C3	60A -	13	14	15	14	N-end	
IE3-W41R 200 LX2C	6312 C3	NU 312 E	RB60	-	130	6312 C3	60A -	13	14	15	14	N-end	
IE3-W41R 225 M2	6313 C3	NU 313 E	RB65	-	140	6313 C3	65A -	13	14	15	14	N-end	
IE3-W41R 250 M2	6314 C3	NU 314 E	RB70	-	150	6314 C3	70A -	13	14	15	14	N-end	
IE3-W41R 180 M4	6310 C3	NU 310 E	RB50	110	-	6310 C3	50A -	13	14	15	14	N-end	
IE3-W41R 180 L4	6310 C3	NU 310 E	RB50	110	-	6310 C3	50A -	13	14	15	14	N-end	
IE3-W41R 200 L4C	6312 C3	NU 312 E	RB60	-	130	6312 C3	60A -	13	14	15	14	N-end	
IE3-W41R 225 S4C	6313 C3	NU 313 E	RB65	-	140	6312 C3	60A -	13	14	15	14	N-end	
IE3-W41R 225 M4	6314 C3	NU 314 E	RB70	-	150	6313 C3	65A -	13	14	15	14	N-end	
IE3-W41R 250 M4	6316 C3	NU 316 E	RB80	-	170	6314 C3	70A -	13	14	15	14	N-end	
IE3-W41R 132 S6													
IE3-W41R 132 M6	6308 C3	NU 308	RB40	90	-	6308 C3	RB40	13	14	15	14	N-end	
IE3-W41R 132 MX6	6308 C3	NU 308	RB40	90	-	6308 C3	RB40	13	14	15	14	N-end	
IE3-W41R 160 M6	6310 C3	NU 310 E	50	110	-	6309 C3	- RB45	13	14	15	14	N-end	
IE3-W41R 160 L6C	6310 C3	NU 310 E	50	110	-	6309 C3	- RB45	13	14	15	14	N-end	
IE3-W41R 180 L6C	6310 C3	NU 310 E	RB50	110	-	6310 C3	50A -	13	14	15	14	N-end	
IE3-W41R 200 L6	6312 C3	NU 312 E	RB60	-	130	6312 C3	60A -	13	14	15	14	N-end	
IE3-W41R 200 LX6C	6312 C3	NU 312 E	RB60	-	130	6312 C3	60A -	13	14	15	14	N-end	
IE3-W41R 225 M6	6314 C3	NU 314 E	RB70	-	150	6313 C3	65A -	13	14	15	14	N-end	
IE3-W41R 250 M6	6316 C3	NU 316 E	RB80	-	170	6314 C3	70A -	13	14	15	14	N-end	
IE3-W41R 280 S2	6314 C3	NU 314 E	RB70	-	150	6314 C3	70A -	13	14	15	14	N-end	
IE3-W41R 280 M2	6314 C3	NU 314 E	RB70	-	150	6314 C3	70A -	13	14	15	14	N-end	
IE3-W41R 280 S4	6316 C3	NU 316 E	RB80	-	170	6314 C3	70A -	13	14	15	14	N-end	
IE3-W41R 280 M4	6317 C3	NU 317 E	RB85	-	180	6316 C3	80A -	13	14	15	14	N-end	
IE3-W41R 280 S6, M6	6317 C3	NU 317 E	RB85	-	180	6316 C3	80A -	13	14	15	14	N-end	
IE3-W41R 315 S2, M2	6316 C3	NU 316 E	RB80	-	170	6316 C3	80A -	13	14	15	14	N-end	
IE3-W41R 315 MX2													
IE3-W41R 315 MY2, L2, LX2													
IE3-W41R 315 S4, M4	6317 C3	NU 317 E	RB85	-	180	6316 C3	80A -	13	14	15	14	N-end	
IE3-W41R 315 MX4													
IE3-W41R 315 MY4													
IE3-W41R 315 L4, LX4													
IE3-W41R 315 S6													
IE3-W41R 315 M6, MX6, MY6													
IE3-W41R 355 M2													
IE3-W41R 355 M4, 6													

¹⁾ Light-duty bearings only

Bearings corresponding to fire-gas classes FV, FV1, FV2 and FV3

For fire-gas class FV4, only bearings with a solid brass cage are used

Energy-saving motors IE2-W.1R

Type	D-end				N-end				Figure		Fixed bearing
	Anti-friction bearing					Anti-friction bearing			D-end	N-end	
		V-ring	γ-ring	Wave spring	Disc spring		V-ring	γ-ring			
IE2-WE1R 132 SX2	6308 ZZ C3	-	RB40	90	-	6308 ZZ C3	-	RB40	6	8	N-end
IE2-WE1R 132 M4, M6, MX6	6308 ZZ C3	-	RB40	90	-	6308 ZZ C3	-	RB40	6	8	N-end
IE2-W21R 132 S6	6208 ZZ C3	-	RB40	80	-	6207 ZZ C3	-	RB35	6	8	N-end
IE2-WE1R 132 S8	6208 ZZ C3	-	RB40	80	-	6207 ZZ C3	-	RB35	6	8	N-end
IE2-WE1R 132 M8	6308 ZZ C3	-	RB40	90	-	6308 ZZ C3	-	RB40	6	8	N-end
IE2-WE1R 160 M2, M4	6310 ZZ C3	-	RB50	110	-	6309 ZZ C3	-	RB45	6	8	N-end
IE2-WE1R 160 MX2, L2, L4	6310 ZZ C3	-	RB50	110	-	6309 ZZ C3	-	RB45	6	8	N-end
IE2-WE1R 160 M6	6310 ZZ C3	-	RB50	110	-	6309 ZZ C3	-	RB45	6	8	N-end
IE2-WE1R 160 L6	6310 ZZ C3	-	RB50	110	-	6309 ZZ C3	-	RB45	6	8	N-end
IE2-WE1R 160 M8	6309 ZZ C3	-	RB45	100	-	6308 ZZ C3	-	RB40	6	8	N-end
IE2-WE1R 160 MX8, L8	6310 ZZ C3	-	RB50	110	-	6309 ZZ C3	-	RB45	6	8	N-end
IE2-WE1R 180 M2, M4, L4, L6	6310 C3	50A	-	110	-	6310 C3	50A	-	6	8	N-end
IE2-WE1R 180 L8	6310 ZZ C3	-	RB50	110	-	6310 ZZ C3	-	RB50	6	8	N-end
IE2-WE1R 200 L2, LX2	6312 C3	60A	-	-	130	6310 C3	50A	-	6	8	N-end
IE2-WE1R 200 L4, LX6	6312 C3	60A	-	-	130	6312 C3	60A	-	6	8	N-end
IE2-WE1R 200 L6	6312 C3	60A	-	-	130	6310 C3	50A	-	6	8	N-end
IE2-WE1R 200 L8	6312 C3	60A	-	-	130	6310 C3	50A	-	6	8	N-end
IE2-WE1R 225 M2	6312 C3	60A	-	-	140	6312 C3	60A	-	6	8	N-end
IE2-WE1R 225 S4	6313 C3	65A	-	-	140	6312 C3	60A	-	6	8	N-end
IE2-WE1R 225 M4, M6	6314 C3	70A	-	-	140	6313 C3	65A	-	6	8	N-end
IE2-WE1R 225 S8	6313 C3	65A	-	-	140	6312 C3	60A	-	6	8	N-end
IE2-WE1R 225 M8	6314 C3	70A	-	-	150	6313 C3	65A	-	6	8	N-end
IE2-WE1R 250 M2	6313 C3	65A	-	-	140	6313 C3	65A	-	6	8	N-end
IE2-WE1R 250 M4	6314 C3	70A	-	-	150	6313 C3	65A	-	6	8	N-end
IE2-WE1R 250 M6	6316 C3	70A	-	-	150	6314 C3	70A	-	6	8	N-end
IE2-WE1R 250 M8	6316 C3	80A	-	-	170	6314 C3	70A	-	6	8	N-end
IE2-WE1R 280 S2, M2	6314 C3	70A	-	-	150	6314 C3	70A	-	6	8	N-end
IE2-WE1R 280 S4, M4	6316 C3	80A	-	-	170	6314 C3	70A	-	6	8	N-end
IE2-WE1R 280 S6	6316 C3	80A	-	-	170	6314 C3	70A	-	6	8	N-end
IE2-WE1R 280 M6	6317 C3	85A	-	-	170	6316 C3	80A	-	6	8	N-end
IE2-WE1R 280 S8	6316 C3	80A	-	-	170	6314 C3	70A	-	6	8	N-end
IE2-WE1R 280 M8	6317 C3	85A	-	-	180	6316 C3	80A	-	6	8	N-end
IE2-WE1R 315 S2, M2	6316 C3	80A	-	-	170	6316 C3	80A	-	6	8	N-end
IE2-WE1R 315 S4, 6; M4	6317 C3	85A	-	-	180	6316 C3	80A	-	6	8	N-end
IE2-WE1R 315 M6	6220 C3	-	RB100	-	180	6316 C3	80A	-	13	16	N-end
IE2-WE1R 315 MX2	6317 C3	-	RB85	-	180	6316 C3	80A	-	13	16	N-end
IE2-WE1R 315 MX4	6220 C3	-	RB100	-	180	6316 C3	80A	-	13	16	N-end
IE2-WE1R 315 MX6	6320 C3	-	RB100	-	215	6317 C3 ¹⁾	85A	-	18	19	N-end
IE2-WE1R 315 MY2	6317 C3	-	RB85	-	180	6317 C3 ¹⁾	85A	-	18	19	N-end
IE2-WE1R 315 L2, LX2	6317 C3	-	RB85	-	180	6317 C3 ¹⁾	85A	-	18	19	N-end
IE2-WE1R 315 L4, 6; LX4, 6	6320 C3	-	RB100	-	215	6317 C3 ¹⁾	85A	-	18	19	N-end
IE2-WE1R 315 S8	6317 C3	85A	-	-	180	6316 C3	80A	-	6	8	N-end
IE2-WE1R 315 M8	6220 C3	-	RB100	-	180	6316 C3	80A	-	13	16	N-end
IE2-WE1R 315 MX8	6320 C3	-	RB100	-	215	6317 C3 ¹⁾	85A	-	18	19	N-end
IE2-WE1R 315 MY8	6320 C3	-	RB100	-	215	6317 C3 ¹⁾	85A	-	18	19	N-end
IE2-WE1R 315 L8, LX8	6320 C3	-	RB100	-	215	6317 C3 ¹⁾	85A	-	18	19	N-end

¹⁾ For types for vertical mounting Q317 C3; figures 18, 21
 (IE2-)WE1R 315 M6; MX; MY; L; LX with relubrication device as standard
 Bearings corresponding to fire-gas classes FV, FV1, FV2 and FV3
 For fire-gas class FV4, only bearings with a solid brass cage are used

Energy-saving motors IE2-W.1R

Relubrication device

Type	D-end					N-end		Figure				Fixed bearing
	Anti-friction bearing					Anti-friction bearing		D-end	N-end	D-end	N-end	
	Light-duty Bearings	Reinforced Bearings	γ-ring	Wave spring ¹⁾	Disc spring ¹⁾	V-ring	Light-duty Bearings	Light-duty Bearings	Reinforced Bearings	Reinforced Bearings		
IE2-WE1R 132 SX2	6308 C3	NU 308 E	RB40	90	-	6308 C3	40A	13	14	15	14	N-end
IE2-WE1R 132 M4, M6, MX6	6308 C3	NU 308 E	RB40	90	-	6308 C3	40A	13	14	15	14	N-end
IE2-WE1R 132 S6	not possible at D-end for design reasons											
IE2-WE1R 132 S8	not possible at D-end for design reasons											
IE2-WE1R 132 M8	6308 C3	NU 308 E	RB40	90	-	6308 C3	40A	13	14	15	14	N-end
IE2-WE1R 160 M2, M4	6310 C3	NU 310 E	RB50	110	-	6309 C3	45A	13	14	15	14	N-end
IE2-WE1R 160 MX2, L2, L4	6310 C3	NU 310 E	RB50	110	-	6309 C3	45A	13	14	15	14	N-end
IE2-WE1R 160 M6	6310 C3	NU 310 E	RB50	110	-	6309 C3	45A	13	14	15	14	N-end
IE2-WE1R 160 L6	6310 C3	NU 310 E	RB50	110	-	6309 C3	45A	13	14	15	14	N-end
IE2-WE1R 160 M8	not possible at D-end for design reasons											
IE2-WE1R 160 MX8, L8	6310 C3	NU 310 E	RB50	110	-	6309 2Z C3	-	13	14	15	14	N-end
IE2-WE1R 180 M2, M4, L4, L6	6310 C3	NU 310 E	RB50	110	-	6310 C3	50A	13	14	15	14	N-end
IE2-WE1R 180 L8	6310 C3	NU 310 E	RB50	110	-	6310 2Z C3	-	13	14	15	14	N-end
IE2-WE1R 200 L2, LX2	6312 C3	NU 312 E	RB60	-	130	6310 C3	50A	13	14	15	14	N-end
IE2-WE1R 200 L4, LX6	6312 C3	NU 312 E	RB60	-	130	6312 C3	60A	13	14	15	14	N-end
IE2-WE1R 200 L6	6312 C3	NU 312 E	RB60	-	130	6310 C3	50A	13	14	15	14	N-end
IE2-WE1R 200 L8	6312 C3	NU 312 E	RB60	-	130	6310 C3	50A	13	14	15	14	N-end
IE2-WE1R 225 M2	6312 C3	NU 312 E	RB60	-	130	6312 C3	60A	13	14	15	14	N-end
IE2-WE1R 225 S4	6313 C3	NU 313 E	RB65	-	140	6312 C3	60A	13	14	15	14	N-end
IE2-WE1R 225 M4, M6	6314 C3	NU 314 E	RB70	-	150	6313 C3	60A	13	14	15	14	N-end
IE2-WE1R 225 S8	6313 C3	NU 313 E	RB65	-	140	6312 C3	60A	13	14	15	14	N-end
IE2-WE1R 225 M8	6314 C3	NU 314 E	RB70	-	150	6313 C3	65A	13	14	15	14	N-end
IE2-WE1R 250 M2	6313 C3	NU 313 E	RB65	-	140	6313 C3	65A	13	14	15	14	N-end
IE2-WE1R 250 M4	6314 C3	NU 314 E	RB70	-	150	6313 C3	65A	13	14	15	14	N-end
IE2-WE1R 250 M6	6316 C3	NU 316 E	RB80	-	170	6314 C3	70A	13	14	15	14	N-end
IE2-WE1R 250 M8	6316 C3	NU 316 E	RB80	-	170	6314 C3	70A	13	14	15	14	N-end
IE2-WE1R 280 S2, M2	6314 C3	NU 314 E	RB70	-	150	6314 C3	70A	13	14	15	14	N-end
IE2-WE1R 280 S4, M4	6316 C3	NU 316 E	RB80	-	170	6314 C3	70A	13	14	15	14	N-end
IE2-WE1R 280 S6	6316 C3	NU 316 E	RB80	-	170	6314 C3	70A	13	14	15	14	N-end
IE2-WE1R 280 M6	6317 C3	NU 317 E	RB85	-	180	6316 C3	80A	13	14	15	14	N-end
IE2-WE1R 280 S8	6316 C3	NU 316 E	RB80	-	170	6314 C3	70A	13	14	15	14	N-end
IE2-WE1R 280 M8	6317 C3	NU 317 E	RB85	-	180	6316 C3	80A	13	14	15	14	N-end
IE2-WE1R 315 S2, M2	6316 C3	NU 316 E	RB80	-	170	6316 C3	80A	13	14	15	14	N-end
IE2-WE1R 315 S4, 6; M4	6317 C3	NU 317 E	RB85	-	180	6316 C3	80A	13	14	15	14	N-end
IE2-WE1R 315 M6	see basic version											
IE2-WE1R 315 MX2	see basic version											
IE2-WE1R 315 MX4	see basic version											
IE2-WE1R 315 MX6	see basic version											
IE2-WE1R 315 MY2	see basic version											
IE2-WE1R 315 L2, LX2	see basic version											
IE2-WE1R 315 L4, 6; LX4, 6	see basic version											
IE2-WE1R 315 S8	6317 C3	NU 317 E	RB85	-	180	6316 C3	80A	13	14	15	14	N-end
IE2-WE1R 315 M8	see basic version											
IE2-WE1R 315 MX8	see basic version											
IE2-WE1R 315 MY8	see basic version											
IE2-WE1R 315 L8, LX8	see basic version											

¹⁾ Light-duty bearings only

Bearings corresponding to fire-gas classes FV, FV1, FV2 and FV3

For fire-gas class FV4, only bearings with a solid brass cage are used

Standard

Type	Anti-friction bearing	D-end				N-end		Figure		Fixed bearing
		V-ring	γ-ring	Wave spring	Disc spring	V-ring	γ-ring	D-end N-end		
(IE1-)K11R 132 S, SX2, M6, 8	6208 2RS C3	-	RB40	80	-	6207 2RS C3	-	RB35	6 8	N-end
(IE1-)K11R 132 M4, MX6	6308 2RS C3	-	RB40	90	-	6308 2RS C3	-	RB40	6 8	N-end
(IE1-)K11R 160 M, MX6	6309 2RS C3	-	RB45	100	-	6308 2RS C3	-	RB40	6 8	N-end
(IE1-)K11R 160 MX2, L	6310 2RS C3	-	RB50	110	-	6309 2RS C3	-	RB45	6 8	N-end
(IE1-)K11R 180 M4, L6, 8	6310 2RS C3	-	RB50	110	-	6309 2RS C3	-	RB45	6 8	N-end
(IE1-)K11R 180 M2, L4	6310 C3	50A	-	110	-	6310 C3	50A	-	6 8	N-end
(IE1-)K11R 200 L, LX6	6312 C3	60A	-	-	130	6310 C3	50A	-	6 8	N-end
(IE1-)K11R 200 LX2	6312 C3	60A	-	-	130	6312 C3	60A	-	6 8	N-end
(IE1-)K11R 225 M2	6312 C3	60A	-	-	130	6312 C3	60A	-	6 8	N-end
(IE1-)K11R 225 S4, 8, M4, 6, 8	6313 C3	65A	-	-	140	6312 C3	60A	-	6 8	N-end
(IE1-)K11R 250 M2	6313 C3	65A	-	-	140	6313 C3	65A	-	6 8	N-end
(IE1-)K11R 250 M4, 6, 8	6314 C3	70A	-	-	150	6313 C3	65A	-	6 8	N-end
(IE1-)K11R 280 S2, M2	6314 C3	70A	-	-	150	6314 C3	70A	-	6 8	N-end
(IE1-)K11R 280 S4, 6, 8, M4, 6, 8	6316 C3	80A	-	-	170	6314 C3	70A	-	6 8	N-end
(IE1-)K11R 315 S2, M2	6316 C3	80A	-	-	170	6316 C3	80A	-	6 8	N-end
(IE1-)K11R 315 S4, 6, 8, M4, 6, 8	6317 C3	85A	-	-	180	6316 C3	80A	-	6 8	N-end
(IE1-)K11R 315 MX2	6317 C3	-	RB85	-	180	6316 C3	80A	-	13 16	N-end
(IE1-)K11R 315 MX4, 6, 8	6220 C3	-	RB100	-	180	6316 C3	80A	-	13 16	N-end
(IE1-)K11R 315 MY2	6317 C3	-	RB85	-	180	6317 C3 ¹⁾	85A	-	18 19	N-end
(IE1-)K11R 315 MY4, 6, 8	6320 C3	-	RB100	-	215	6317 C3 ¹⁾	85A	-	18 19	N-end
(IE1-)K11R 315 L2, LX2	6317 C3	-	RB85	-	180	6317 C3 ¹⁾	85A	-	18 19	N-end
(IE1-)K11R 315 L4, 6, 8, LX4, 6, 8	6320 C3	-	RB100	-	215	6317 C3 ¹⁾	85A	-	18 19	N-end
(IE1-)K22R 355 MY/M/MX/LY/L 2-pole	6317 C3	-	RB85	-	180	6317 C3 ¹⁾	85A	-	18 19	N-end
(IE1-)K22R 355 MY/M/MX/LY/L 4-, 6-, 8-pole	6324 C3	-	RB120	-	260	6317 C3 ¹⁾	85A	-	18 19	N-end

¹⁾ For types for vertical mounting Q317 C3; figures 18, 21
 From size (IE1-)K11R 315 MX with relubrication device as standard
 Bearings corresponding to fire-gas classes FV, FV1, FV2 and FV3
 For fire-gas class FV4, only bearings with a solid brass cage are used

Type	Anti-friction bearing	D-end				N-end		Figure		Fixed bearing
		V-ring	γ-ring	Wave spring	Disc spring	V-ring	γ-ring	D-end N-end		
(IE1-)K10R 132 S, M	6308 2RS C3	-	RB40	90	-	6308 2RS C3	-	RB40	6 8	N-end
(IE1-)K10R 160 S, M	6310 2RS C3	-	RB50	110	-	6309 2RS C3	-	RB45	6 8	N-end
(IE1-)K10R 180 S2, M2	6310 C3	50A	-	110	-	6310 C3	50A	-	6 8	N-end
(IE1-)K10R 180 S4, 6, 8, M4, 6, 8	6312 C3	60A	-	-	130	6310 C3	50A	-	6 8	N-end
(IE1-)K10R 200 M2, L2	6312 C3	60A	-	-	130	6312 C3	60A	-	6 8	N-end
(IE1-)K10R 200 M4, 6, 8, L4, 6, 8	6313 C3	65A	-	-	140	6312 C3	60A	-	6 8	N-end
(IE1-)K10R 225 M2	6313 C3	65A	-	-	140	6313 C3	65A	-	6 8	N-end
(IE1-)K10R 225 M4, 6, 8	6314 C3	70A	-	-	150	6313 C3	65A	-	6 8	N-end
(IE1-)K10R 250 S2, M2	6314 C3	70A	-	-	150	6314 C3	70A	-	6 8	N-end
(IE1-)K10R 250 S4, 6, 8, M4, 6, 8	6316 C3	80A	-	-	170	6314 C3	70A	-	6 8	N-end
(IE1-)K10R 280 S2, M2	6316 C3	80A	-	-	170	6316 C3	80A	-	6 8	N-end
(IE1-)K10R 280 S4, 6, 8, M4, 6, 8	6317 C3	85A	-	-	180	6316 C3	80A	-	6 8	N-end
(IE1-)K10R 315 S2	6317 C3	-	RB85	-	180	6316 C3	80A	-	13 16	N-end
(IE1-)K10R 315 S4, 6, 8	6220 C3	-	RB100	-	180	6316 C3	80A	-	13 16	N-end
(IE1-)K10R 315 M2, L2, LX2	6317 C3	-	RB85	-	180	6317 C3 ¹⁾	85A	-	18 19	N-end
(IE1-)K10R 315 M4, 6, 8, L4, 6, 8, LX4, 6, 8	6320 C3	-	RB100	-	215	6317 C3 ¹⁾	85A	-	18 19	N-end

¹⁾ For types for vertical mounting Q317 C3; figures 18, 21
 From size (IE1-)K11R 315 MX with relubrication device as standard
 Bearings corresponding to fire-gas classes FV, FV1, FV2 and FV3
 For fire-gas class FV4, only bearings with a solid brass cage are used

Relubrication device

Type	D-end					N-end		Figure				Fixed bearing
	Anti-friction bearing					Anti-friction bearing		D-end N-end D-end N-end				
	Light-duty Bearings	Reinforced Bearings	γ-ring	Wave spring ¹⁾	Disc spring ¹⁾	V-ring	Light-duty Bearings	Light-duty Bearings	Reinforced Bearings	Reinforced Bearings		
(IE1-)K11R 132 S, SX2, M6, 8	not possible at D-end for design reasons											
(IE1-)K11R 132 M4, MX6	6308 C3	NU308 E	RB40	90		6308 C3	40A	13	14	15	14	N-end
(IE1-)K11R 160 M, MX6	not possible at D-end for design reasons											
(IE1-)K11R 160 MX2, L	6310 C3	NU 310 E	RB50	110	-	6309 C3	45A	13	14	15	14	N-end
(IE1-)K11R 180 M4, L6, 8	6310 C3	NU 310 E	RB50	110	-	6309 C3	45A	13	14	15	14	N-end
(IE1-)K11R 180 M2, L4	6310 C3	NU 310 E	RB50	110	-	6310 C3	50A	13	14	15	14	N-end
(IE1-)K11R 200 L, LX6	6312 C3	NU 312 E	RB60	-	130	6310 C3	50A	13	14	15	14	N-end
(IE1-)K11R 200 LX2	6312 C3	NU 312 E	RB60	-	130	6312 C3	60A	13	14	15	14	N-end
(IE1-)K11R 225 M2	6312 C3	NU 312 E	RB60	-	130	6312 C3	60A	13	14	15	14	N-end
(IE1-)K11R 225 S4, 8, M4, 6, 8	6313 C3	NU 313 E	RB65	-	140	6312 C3	60A	13	14	15	14	N-end
(IE1-)K11R 250 M2	6313 C3	NU 313 E	RB65	-	140	6313 C3	65A	13	14	15	14	N-end
(IE1-)K11R 250 M4, 6, 8	6314 C3	NU 314 E	RB70	-	150	6313 C3	65A	13	14	15	14	N-end
(IE1-)K11R 280 S2, M2	6314 C3	NU 314 E	RB70	-	150	6314 C3	70A	13	14	15	14	N-end
(IE1-)K11R 280 S4, 6, 8, M4, 6, 8	6316 C3	NU 316 E	RB80	-	170	6314 C3	70A	13	14	15	14	N-end
(IE1-)K11R 315 S2, M2	6316 C3	NU 316 E	RB80	-	170	6316 C3	80A	13	14	15	14	N-end
(IE1-)K11R 315 S4, 6, 8, M4, 6, 8	6317 C3	NU 317 E	RB85	-	180	6316 C3	80A	13	14	15	14	N-end
(IE1-)K11R 315 MX2							see basic version					
(IE1-)K11R 315 MX4, 6, 8							see basic version					
(IE1-)K11R 315 MY2							see basic version					
(IE1-)K11R 315 MY4, 6, 8							see basic version					
(IE1-)K11R 315 L2, LX2							see basic version					
(IE1-)K11R 315 L4, 6, 8, LX4, 6, 8							see basic version					
(IE1-)K22R 355 MY/M/MX/LY/L 2-pole							see basic version					
(IE1-)K22R 355 MY/M/MX/LY/L 4-, 6-, 8-pole							see basic version					

¹⁾ Light-duty bearings only

Bearings corresponding to fire-gas classes FV, FV1, FV2 and FV3

For fire-gas class FV4, only bearings with a solid brass cage are used

Type	D-end					N-end		Figure				Fixed bearing
	Anti-friction bearing					Anti-friction bearing		D-end N-end D-end N-end				
	Light-duty Bearings	Reinforced Bearings	γ-ring	Wave spring ¹⁾	Disc spring ¹⁾	V-ring	Light-duty Bearings	Light-duty Bearings	Reinforced Bearings	Reinforced Bearings		
(IE1)-K10R 132 S, M	6308 C3	NU 308 E	RB40	90	-	6308 C3	40A	13	14	15	14	N-end
(IE1)-K10R 160 S, M	6310 C3	NU 310 E	RB50	110	-	6309 C3	45A	13	14	15	14	N-end
(IE1)-K10R 180 S2, M2	6310 C3	NU 310 E	RB50	110	-	6310 C3	50A	13	14	15	14	N-end
(IE1)-K10R 180 S4, 6, 8, M4, 6, 8	6312 C3	NU 312 E	RB60	-	130	6310 C3	50A	13	14	15	14	N-end
(IE1)-K10R 200 M2, L2	6312 C3	NU 312 E	RB60	-	130	6312 C3	60A	13	14	15	14	N-end
(IE1)-K10R 200 M4, 6, 8, L4, 6, 8	6313 C3	NU 313 E	RB65	-	140	6312 C3	60A	13	14	15	14	N-end
(IE1)-K10R 225 M2	6313 C3	NU 313 E	RB65	-	140	6313 C3	65A	13	14	15	14	N-end
(IE1)-K10R 225 M4, 6, 8	6314 C3	NU 314 E	RB70	-	150	6313 C3	65A	13	14	15	14	N-end
(IE1)-K10R 250 S2, M2	6314 C3	NU 314 E	RB70	-	150	6314 C3	70A	13	14	15	14	N-end
(IE1)-K10R 250 S4, 6, 8, M4, 6, 8	6316 C3	NU 316 E	RB80	-	170	6314 C3	70A	13	14	15	14	N-end
(IE1)-K10R 280 S2, M2	6316 C3	NU 316 E	RB80	-	170	6316 C3	80A	13	14	15	14	N-end
(IE1)-K10R 280 S4, 6, 8, M4, 6, 8	6317 C3	NU 317 E	RB85	-	180	6316 C3	80A	13	14	15	14	N-end
(IE1)-K10R 315 S2							see basic version					
(IE1)-K10R 315 S4, 6, 8							see basic version					
(IE1)-K10R 315 M2, L2, LX2							see basic version					
(IE1)-K10R 315 M4, 6, 8, L4, 6, 8, LX4, 6, 8							see basic version					

¹⁾ Light-duty bearings only

Bearings corresponding to fire-gas classes FV, FV1, FV2 and FV3

For fire-gas class FV4, only bearings with a solid brass cage are used

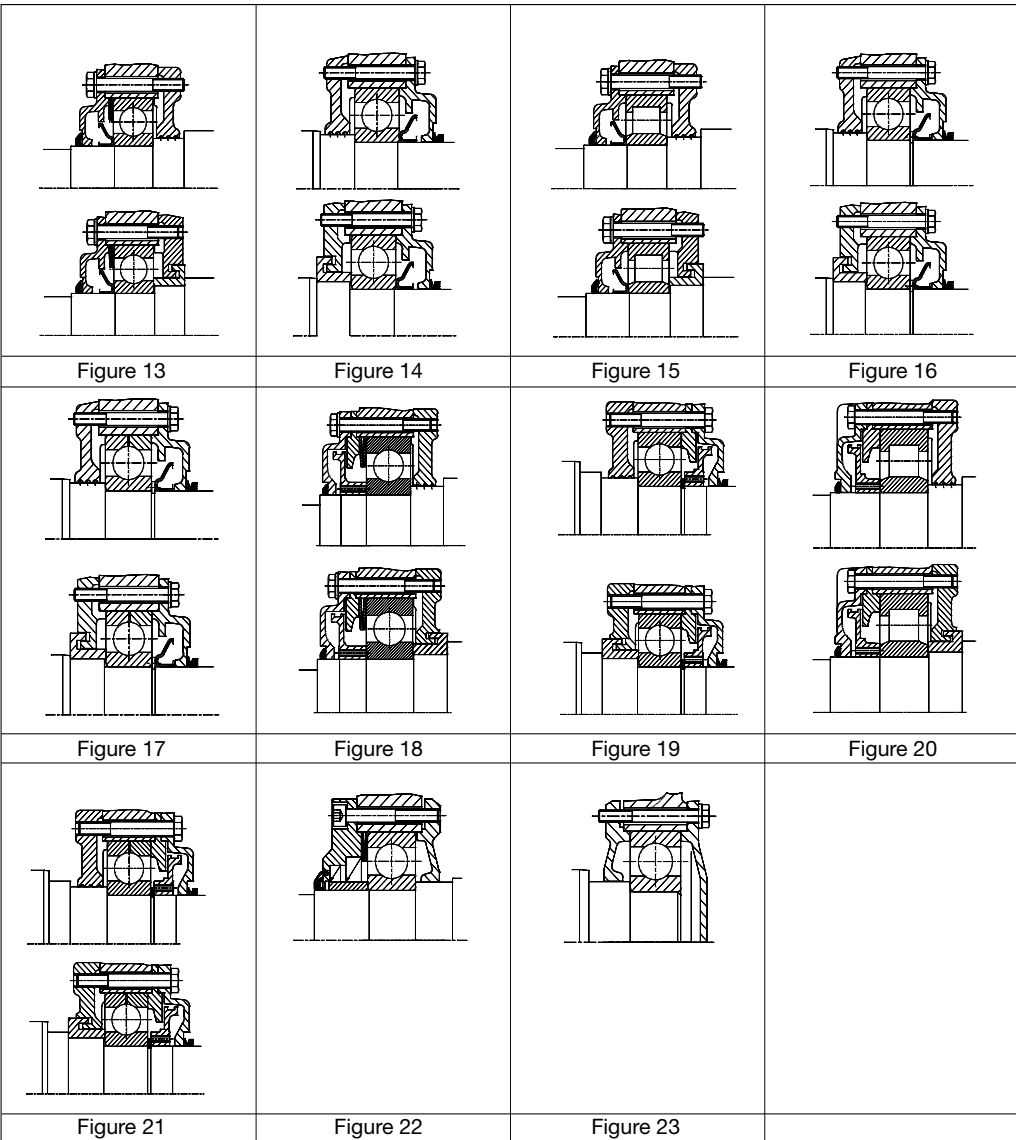
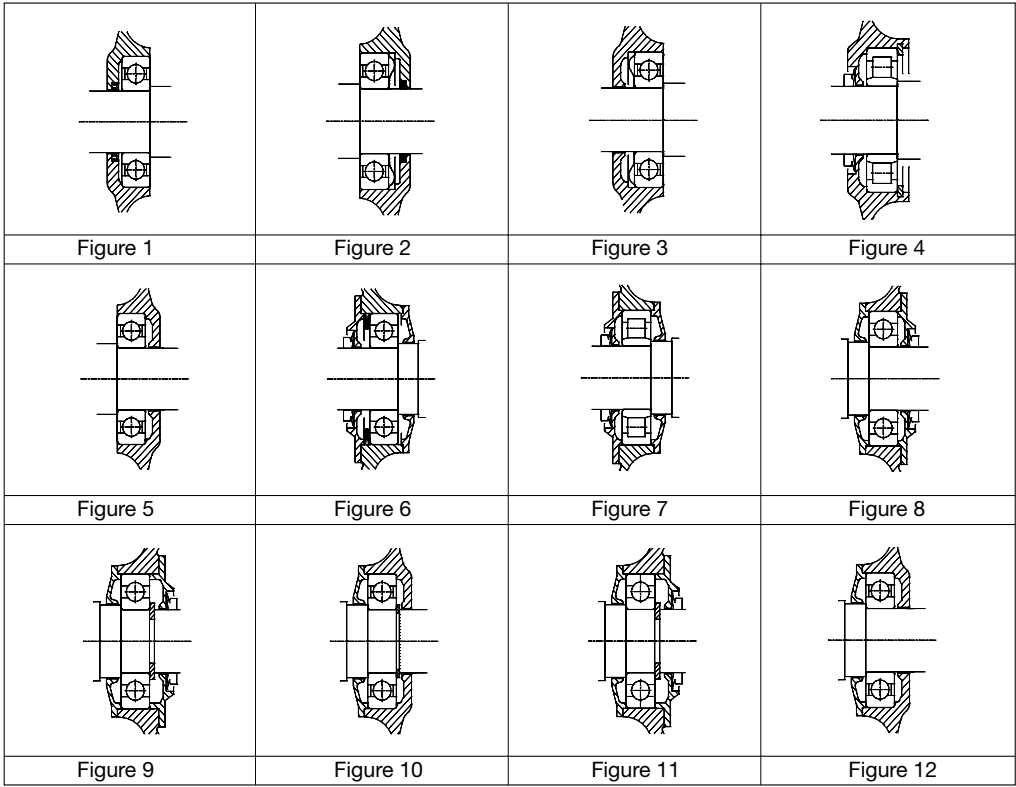

Dimensions

Flange dimensions

Flanges with threaded holes

Flange type to E DIN EN 50347	Flange type to DIN 42948	LA c ₁	M e ₁	N b ₁	P a ₁	S s ₁	T f ₁
FT 65	C 80	6,5	65	50	80	M5	2,5
FT 75	C 90	8	75	60	90	M5	2,5
FT 85	C 105	8,5	85	70	105	M6	2,5
FT 100	C 120	8	100	80	120	M6	3
FT 115	C 140	10	115	95	140	M8	3
FT 130	C 160	10	130	110	160	M8	3,5
FT 165	C 200	12	165	130	200	M10	3,5
FT 215	C 250	12	215	180	250	M12	4

Flanges with through-holes

Flange type to E DIN EN 50347	Flange type to DIN 42948	LA c ₁	M e ₁	N b ₁	P a ₁	S s ₁	T f ₁
FF 100	A 120	9	100	80	120	7	3
FF 115	A 140	9	115	95	140	9	3
FF 130	A 160	9	130	110	160	9	3,5
FF 165	A 200	10	165	130	200	11	3,5
FF 215	A 250	11	215	180	250	14	4
FF 265	A 300	12	265	230	300	14	4
FF 300	A 350	13	300	250	350	18	5
FF 350	A 400	15	350	300	400	18	5
FF 400	A 450	16	400	350	450	18	5
FF 500	A 550	18	500	450	550	18	5
FF 600	A 660	22	600	550	660	22	6
FF 740	A 800	25	740	680	800	22	6

According to DIN EN 50347, the different sizes of FF flanges possess through-holes, while FT flanges possess threaded holes. The flange designations A and C defined in DIN 42948 remain valid.

Flange assignments which deviate from the standard are specified in the flange assignment tables.

For tolerances for the dimension N (b₁), refer to the corresponding dimension tables LA (c₁) depth of engagement

Three-phase motors with squirrel-cage rotor for use in powered smoke and heat extraction systems to EN 12101-3

Energy-saving motors, Premium Efficiency IE3

Surface cooling, type of cooling IC 418, degree of protection IP 55
Size 132 to 200

Type of construction IM B3 [IM 1001]

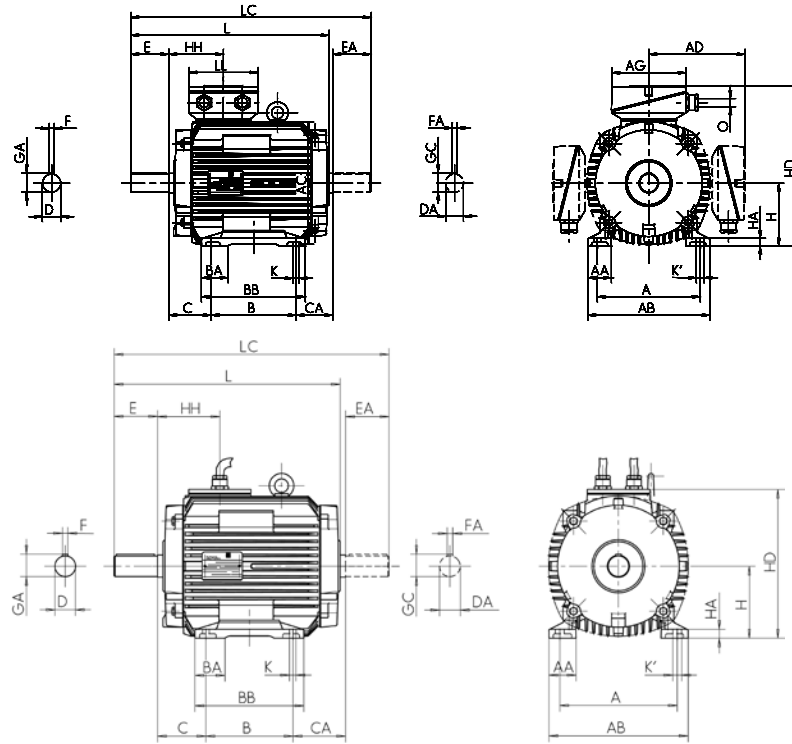

Type designation	Flange size	A	AA	AB	AC	AD	B	BA	BB	C	CA	D	DA	DB ¹⁾	E	EA	F	FA
		b	n	f	g	g1	a	m	e	w1	w2	d	d1	l	l1	u	u1	
IE3-W41R 132 SX2 FAN	FF 265	216	50	256	258	199	140	53	180	89	117	38	32	M12	80	80	10	10
IE3-W41R 132 S4 FAN	FF 265	216	50	256	258	199	140	53	180	89	165	38	32	M12	80	80	10	10
IE3-W41R 132 M4 FAN	FF 265	216	50	256	258	199	178	53	218	89	177	38	38	M12	80	80	10	10
IE3-W41R 132 M6 FAN	FF 265	216	50	256	258	199	178	53	218	89	79	38	32	M12	80	80	10	10
IE3-W41R 132 MX6 FAN	FF 265	216	50	256	258	199	178	53	218	89	177	38	38	M12	80	80	10	10
IE3-W41R 132 S8 FAN	FF 265	216	50	256	258	199	140	53	180	89	117	38	32	M12	80	80	10	10
IE3-W41R 132 M8 FAN	FF 265	216	50	256	258	199	178	53	218	89	79	38	32	M12	80	80	10	10
IE3-W41R 160 M2 FAN	FF 300	254	55	296	313	242	210	56	257	108	87	42	42	M16	110	110	12	12
IE3-W41R 160 MX2 FAN	FF 300	254	55	296	313	242	210	56	257	108	125	42	42	M16	110	110	12	12
IE3-W41R 160 L2 FAN	FF 300	254	55	296	313	242	254	60	301	108	131	42	42	M16	110	110	12	12
IE3-W41R 160 M4 FAN	FF 300	254	55	296	313	242	210	56	257	108	87	42	42	M16	110	110	12	12
IE3-W41R 160 L4C FAN	FF 300	254	55	296	313	242	254	60	301	108	131	42	42	M16	110	110	12	12
IE3-W41R 160 M6 FAN	FF 300	254	55	296	313	242	210	56	257	108	125	42	42	M16	110	110	12	12
IE3-W41R 160 L6C FAN	FF 300	254	55	296	313	242	254	60	301	108	131	42	42	M16	110	110	12	12
IE3-W41R 160 M8 FAN	FF 300	254	55	296	313	242	210	60	257	108	87	42	42	M16	110	110	12	12
IE3-W41R 160 MX8 FAN	FF 300	254	55	296	313	242	210	56	257	108	125	42	42	M16	110	110	12	12
IE3-W41R 160 L8 FAN	FF 300	254	55	296	313	242	254	60	301	108	131	42	42	M16	110	110	12	12
IE3-W41R 180 M2C FAN	FF 300	279	62	328	351	261	241	65	288	121	152	48	48	M16	110	110	14	14
IE3-W41R 180 M4 FAN	FF 300	279	62	328	351	261	241	65	288	121	152	48	48	M16	110	110	14	14
IE3-W41R 180 L4 FAN	FF 300	279	62	328	351	261	279	65	326	121	164	48	48	M16	110	110	14	14
IE3-W41R 180 L6C FAN	FF 300	279	62	328	351	261	279	65	326	121	114	48	48	M16	110	110	14	14
IE3-W41R 180 L8 FAN	FF 300	279	62	328	351	261	279	65	326	121	114	48	48	M16	110	110	14	14
IE3-W41R 200 L2 FAN	FF 350	318	70	372	390	300	305	70	360	133	147	55	55	M20	110	110	16	16
IE3-W41R 200 LX2C FAN	FF 350	318	70	372	390	300	305	70	360	133	147	55	55	M20	110	110	16	16
IE3-W41R 200 L4C FAN	FF 350	318	70	372	390	300	305	70	360	133	147	55	55	M20	110	110	16	16
IE3-W41R 200 L6 FAN	FF 350	318	70	372	390	300	305	70	360	133	147	55	55	M20	110	110	16	16
IE3-W41R 200 LX6C FAN	FF 350	318	70	372	390	300	305	70	360	133	147	55	55	M20	110	110	16	16
IE3-W41R 200 L8 FAN	FF 350	318	70	372	351	261	305	70	360	133	126	55	48	M20	110	110	16	14

¹⁾ Centre holes to DIN 332-DS

Three-phase motors with squirrel-cage rotor for use in powered smoke and heat extraction systems to EN 12101-3 Energy-saving motors, Premium Efficiency IE3

Surface cooling, type of cooling IC 418, degree of protection IP 55
Size 132 to 200

Type of construction IM B35 [IM 2001]

Flange dimensions, see page 8/23

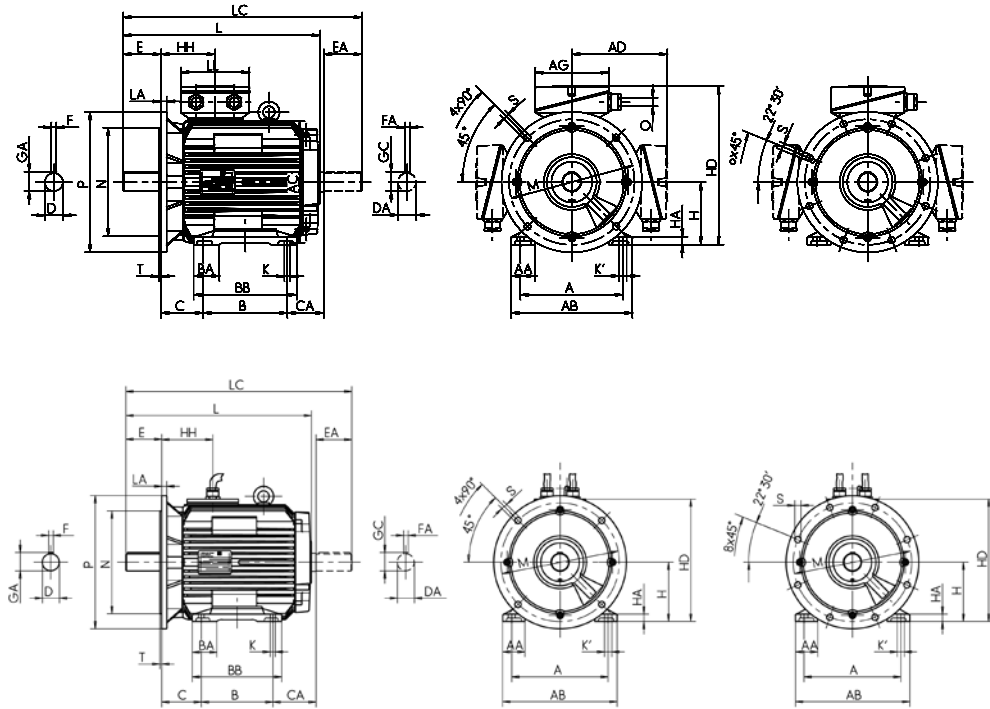

Type designation	GA	GC	H	HA	HD	HD ^{**}	HD	HH	K	K'	L	LC	TB Type	AG	LL	O	Hole	BI
	t	t1	h	c	p	p	p	A	s	s'	k	k1		x	z	-	pattern	BI
IE3-W41R 132 SX2 FAN	41	35	132	15	331	279	276	114	12	12	424	506	25 A	156	145	M32 x 1.5	4L	35
IE3-W41R 132 S4 FAN	41	35	132	15	331	279	276	114	12	12	472	554	25 A	156	145	M32 x 1.5	4L	35
IE3-W41R 132 M4 FAN	41	41	132	15	331	279	276	114	12	12	522	604	25 A	156	145	M32 x 1.5	4L	35
IE3-W41R 132 M6 FAN	41	35	132	16	331	279	276	114	12	12	424	506	25 A	156	145	M32 x 1.5	4L	35
IE3-W41R 132 MX6 FAN	41	41	132	15	331	279	276	114	12	12	522	604	25 A	156	145	M32 x 1.5	4L	35
IE3-W41R 132 S8 FAN	41	35	132	16	331	279	276	114	12	12	424	506	25 A	156	145	M32 x 1.5	4L	35
IE3-W41R 132 M8 FAN	41	35	132	16	331	279	276	114	12	12	424	506	25 A	156	145	M32 x 1.5	4L	35
IE3-W41R 160 M2 FAN	45	45	160	18	402	336	332	138	15	20	512	625	63 A	193	167	M40 x 1.5	4L	35
IE3-W41R 160 MX2 FAN	45	45	160	18	402	336	332	138	15	20	550	663	63 A	193	167	M40 x 1.5	4L	35
IE3-W41R 160 L2 FAN	45	45	160	18	402	336	332	138	15	20	600	713	63 A	193	167	M40 x 1.5	4L	35
IE3-W41R 160 M4 FAN	45	45	160	18	402	336	332	138	15	20	512	625	63 A	193	167	M40 x 1.5	4L	35
IE3-W41R 160 L4C FAN	45	45	160	18	402	336	332	138	15	20	600	713	63 A	193	167	M40 x 1.5	4L	35
IE3-W41R 160 M6 FAN	45	45	160	18	402	336	332	138	15	20	550	663	63 A	193	167	M40 x 1.5	4L	35
IE3-W41R 160 L6C FAN	45	45	160	18	402	336	332	138	15	20	600	713	63 A	193	167	M40 x 1.5	4L	35
IE3-W41R 160 M8 FAN	45	45	160	18	402	336	332	138	15	15	512	625	63 A	193	167	M40 x 1.5	4L	35
IE3-W41R 160 MX8 FAN	45	45	160	18	402	336	332	138	15	20	550	663	63 A	193	167	M40 x 1.5	4L	35
IE3-W41R 160 L8 FAN	45	45	160	18	402	336	332	138	15	20	600	713	63 A	193	167	M40 x 1.5	4L	35
IE3-W41R 180 M2C FAN	51.5	51.5	180	20	441	369	371	147	15	20	625	734	63 A	193	167	M40 x 1.5	4L	35
IE3-W41R 180 M4 FAN	51.5	51.5	180	20	441	369	371	147	15	20	625	734	63 A	193	167	M40 x 1.5	4L	35
IE3-W41R 180 L4 FAN	51.5	51.5	180	20	441	369	371	147	15	20	675	784	63 A	193	167	M40 x 1.5	4L	35
IE3-W41R 180 L6C FAN	51.5	51.5	180	20	441	369	371	147	15	20	625	734	63 A	193	167	M40 x 1.5	4L	35
IE3-W41R 180 L8 FAN	51.5	51.5	180	20	441	369	371	147	15	20	625	734	63 A	193	167	M40 x 1.5	4L	35
IE3-W41R 200 L2 FAN	59	59	200	22	500	417	411	168	19	25	698	805	100 A	213	207	M50 x 1.5	4L	40
IE3-W41R 200 LX2C FAN	59	59	200	22	500	417	411	168	19	25	698	805	100 A	213	207	M50 x 1.5	4L	40
IE3-W41R 200 L4C FAN	59	59	200	22	500	417	411	168	19	25	698	805	100 A	213	207	M50 x 1.5	4L	35
IE3-W41R 200 L6 FAN	59	59	200	22	500	417	411	168	19	25	698	805	100 A	213	207	M50 x 1.5	4L	35
IE3-W41R 200 LX6C FAN	59	59	200	22	500	417	411	168	19	25	698	805	100 A	213	207	M50 x 1.5	4L	35
IE3-W41R 200 L8 FAN	59	51.5	200	22	461	389	391	147	19	25	675	784	63 A	193	167	M40 x 1.5	4L	35

***) Terminal box left/right

**Three-phase motors with squirrel-cage rotor for use in powered smoke and heat extraction systems to EN 12101-3
Energy-saving motors, Premium Efficiency IE3**

Surface cooling, type of cooling IC 418, degree of protection IP 55
Size 225 to 280

Type of construction IM B3 [IM 1001]

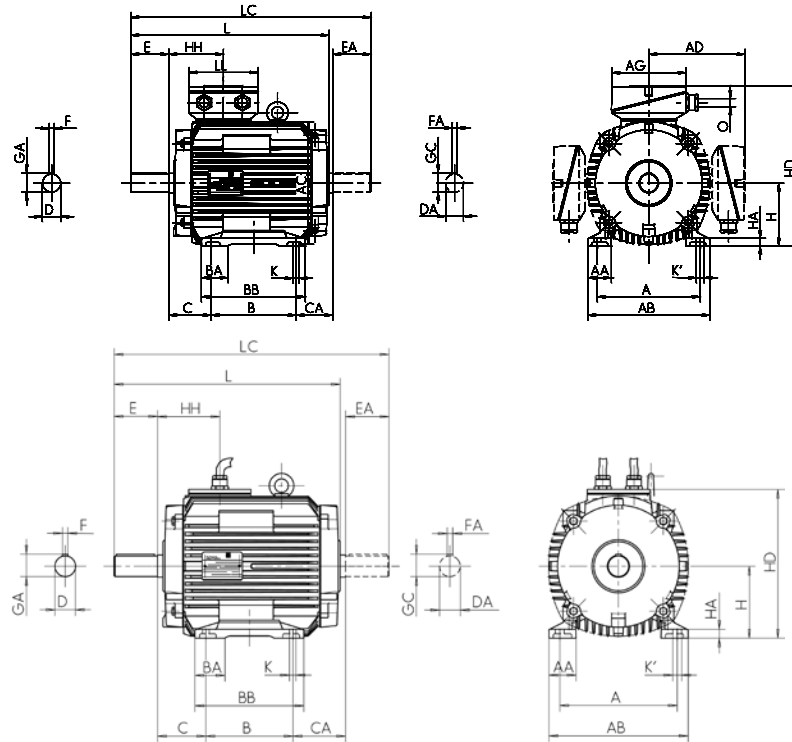

Type designation	Flange size	A	AA	AB	AC	AD	B	BA	BB	C	CA	D	DA	DB ¹⁾	E	EA	F	FA
		b	n	f	g	g1	a	m	e	w1	w2	d	d1	l	l1	u	u1	
IE3-W41R 225 M2 FAN	FF 400	356	75	413	440	324	311	75	368	149	147	55	55	M20	110	110	16	16
IE3-W41R 225 S4C FAN	FF 400	356	75	413	390	300	286	75	343	149	200	60	55	M20	140	110	18	16
IE3-W41R 225 M4 FAN	FF 400	356	75	413	440	324	311	75	368	149	197	60	55	M20	140	110	18	16
IE3-W41R 225 M6 FAN	FF 400	356	75	413	440	324	311	75	368	149	147	60	55	M20	140	110	18	16
IE3-W41R 225 S8 FAN	FF 400	356	75	413	390	300	286	75	343	149	150	60	55	M20	140	110	18	16
IE3-W41R 225 M8 FAN	FF 400	356	75	413	440	324	311	75	368	149	147	60	55	M20	140	110	18	16
IE3-W41R 250 M2 FAN	FF 500	406	84	469	490	386	349	84	374	168	154	60	55	M20	140	110	18	16
IE3-W41R 250 M4 FAN	FF 500	406	84	469	490	386	349	84	412	168	154	65	55	M20	140	110	18	16
IE3-W41R 250 M6 FAN	FF 500	406	84	469	490	386	349	84	412	168	154	65	55	M20	140	110	18	16
IE3-W41R 250 M8 FAN	FF 500	406	84	471	440	386	349	84	412	168	140	65	55	M20	140	110	18	16
IE3-W41R 280 S2 FAN	FF 500	457	94	522	490	386	368	96	431	190	113	65	65	M20	140	140	18	18
IE3-W41R 280 M2 FAN	FF 500	457	94	522	490	386	419	96	482	190	109	65	65	M20	140	140	18	18
IE3-W41R 280 S4 FAN	FF 500	457	94	522	490	386	368	96	431	190	160	75	65	M20	140	140	20	18
IE3-W41R 280 M4 FAN	FF 500	457	88	522	550	416	419	94	482	190	192	75	65	M20	140	140	20	18
IE3-W41R 280 S6 FAN	FF 500	457	88	522	550	416	368	94	431	190	188	75	65	M20	140	140	20	18
IE3-W41R 280 M6 FAN	FF 500	457	88	522	550	416	419	94	482	190	192	75	65	M20	140	140	20	18
IE3-W41R 280 S8 FAN	FF 500	457	94	522	490	386	368	96	431	190	113	75	65	M20	140	140	20	18
IE3-W41R 280 M8 FAN	FF 500	457	88	522	550	416	419	94	482	190	192	75	65	M20	140	140	20	18

¹⁾ Centre holes to DIN 332-DS

Three-phase motors with squirrel-cage rotor for use in powered smoke and heat extraction systems to EN 12101-3 Energy-saving motors, Premium Efficiency IE3

Surface cooling, type of cooling IC 418, degree of protection IP 55
Size 225 to 280

Type of construction IM B35 [IM 2001]

Flange dimensions, see page 8/23

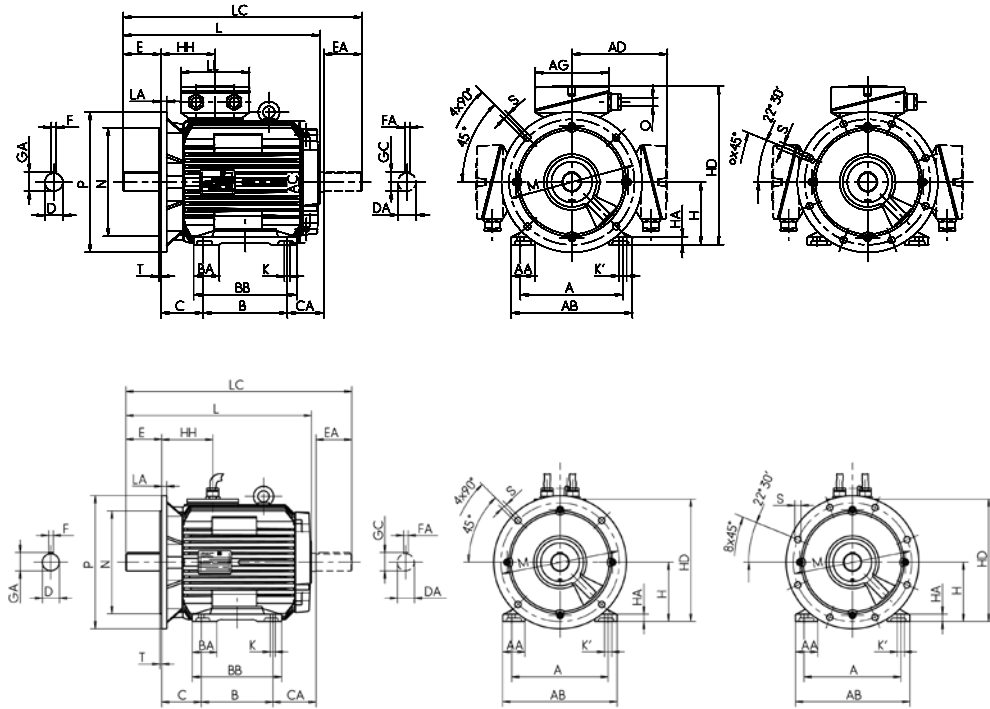

Type designation	GA	GC	H	HA	HD	HD ^{**}	HD	HH	K	K'	L	LC	TB Type	AG	LL	O	Hole	BI
	t	t1	h	c	p	p	p	A	s	s'	k	k1		x	z	-	pattern	Bl
IE3-W41R 225 M2 FAN	59	59	225	25	549	450	460	177	19	25	707	827	100 A	213	207	M50 x 1.5	8L	45
IE3-W41R 225 S4C FAN	64	59	225	25	527	442	436	168	19	25	778	885	100 A	213	207	M50 x 1.5	8L	40
IE3-W41R 225 M4 FAN	64	59	225	25	549	450	460	177	19	25	787	907	100 A	213	207	M50 x 1.5	8L	45
IE3-W41R 225 M6 FAN	64	59	225	25	549	450	460	177	19	25	787	907	100 A	213	207	M50 x 1.5	8L	45
IE3-W41R 225 S8 FAN	64	59	225	25	527	442	436	168	19	25	728	835	100 A	213	207	M50 x 1.5	8L	40
IE3-W41R 225 M8 FAN	64	59	225	25	549	450	460	177	19	25	737	857	100 A	213	207	M50 x 1.5	8L	45
IE3-W41R 250 M2 FAN	64	59	250	28	636	493	535	206	24	30	801	921	200 A	282	242	M63 x 1.5	8L	55
IE3-W41R 250 M4 FAN	69	59	250	28	636	493	535	206	24	30	801	921	200 A	282	242	M63 x 1.5	8L	50
IE3-W41R 250 M6 FAN	69	59	250	28	636	493	535	206	24	30	801	921	200 A	282	242	M63 x 1.5	8L	50
IE3-W41R 250 M8 FAN	69	59	250	28	636	484	485	177	24	30	787	907	200 A	282	242	M63 x 1.5	8L	50
IE3-W41R 280 S2 FAN	69	69	280	32	666	523	565	206	24	30	801	951	200 A	282	242	M63 x 1.5	8L	55
IE3-W41R 280 M2 FAN	69	69	280	32	666	523	565	206	24	30	848	998	200 A	282	242	M63 x 1.5	8L	55
IE3-W41R 280 S4 FAN	79.5	69	280	32	666	523	565	206	24	30	848	998	200 A	282	242	M63 x 1.5	8L	50
IE3-W41R 280 M4 FAN	79.5	69	280	40	696	555	595	211	24	30	934	1081	200 A	282	242	M63 x 1.5	8L	55
IE3-W41R 280 S6 FAN	79.5	69	280	40	696	555	595	211	24	30	879	1026	200 A	282	242	M63 x 1.5	8L	55
IE3-W41R 280 M6 FAN	79.5	69	280	40	696	555	595	211	24	30	934	1081	200 A	282	242	M63 x 1.5	8L	55
IE3-W41R 280 S8 FAN	79.5	69	280	32	666	523	565	206	24	30	801	951	200 A	282	242	M63 x 1.5	8L	55
IE3-W41R 280 M8 FAN	79.5	69	280	40	696	555	595	211	24	30	934	1081	200 A	282	242	M63 x 1.5	8L	55

** Terminal box left/right

**Three-phase motors with squirrel-cage rotor for use in powered smoke and heat extraction systems to EN 12101-3
Energy-saving motors, Premium Efficiency IE3**

Surface cooling, type of cooling IC 418, degree of protection IP 55
Size 315

Type of construction IM B3 [IM 1001]

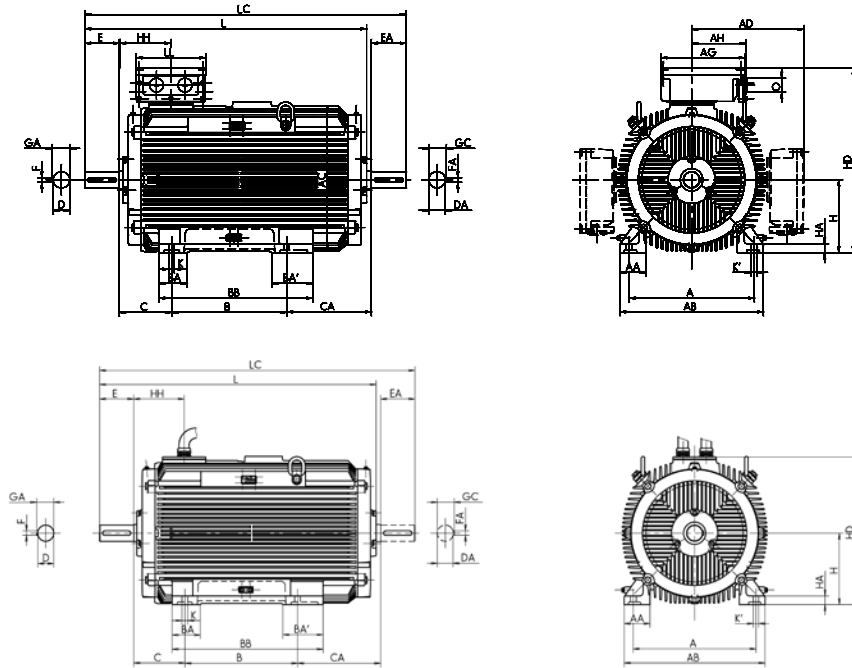

Type designation	Flange size	A	AA	AB	AC	AD	B	BA	BA'	BB	C	CA	D	DA	DB ¹⁾	E	EA	F	FA
		b	n	f	g	g1	a	m	m1	e	w1	w2	d	d1		l	l1	u	u1
IE3-W41R 315 S2 FAN	FF 600	508	126	590	550	416	406	120	-	503	216	124	65	65	M20	140	140	18	18
IE3-W41R 315 M2 FAN	FF 600	508	126	590	550	416	457	120	150	554	216	128	65	65	M20	140	140	18	18
IE3-W41R 315 MX2 FAN	FF 600	508	110	590	610	494	457	120	150	554	216	234	65	65	M20	140	140	18	18
IE3-W41R 315 MY2 FAN	FF 600	508	110	590	610	494	457	120	-	573	216	304	65	65	M20	140	140	18	18
IE3-W41R 315 L2 FAN	FF 600	508	110	590	610	494	508	120	-	624	216	373	65	65	M20	140	140	18	18
IE3-W41R 315 LX2 FAN	FF 600	508	110	590	610	494	508	120	-	624	216	493	65	65	M20	140	140	18	18
IE3-W41R 315 S4 FAN	FF 600	508	126	590	550	416	406	120	-	503	216	124	80	70	M20	170	140	22	20
IE3-W41R 315 M4 FAN	FF 600	508	126	590	550	416	457	120	150	554	216	128	80	70	M20	170	140	22	20
IE3-W41R 315 MX4 FAN	FF 600	508	110	590	610	494	457	120	150	554	216	234	80	70	M20	170	140	22	20
IE3-W41R 315 MY4 FAN	FF 600	508	110	590	610	494	457	120	-	573	216	304	80	70	M20	170	140	22	20
IE3-W41R 315 L4 FAN	FF 600	508	110	590	610	494	508	120	-	624	216	373	80	70	M20	170	140	22	20
IE3-W41R 315 LX4 FAN	FF 600	508	110	590	610	494	508	120	-	624	216	493	80	70	M20	170	140	22	20
IE3-W41R 315 S6 FAN	FF 600	508	110	590	610	494	406	120	150	554	216	285	80	70	M20	170	140	22	20
IE3-W41R 315 M6 FAN	FF 600	508	110	590	610	494	457	120	-	573	216	304	80	70	M20	170	140	22	20
IE3-W41R 315 MX6 FAN	FF 600	508	110	590	610	494	457	120	-	573	216	234	80	70	M20	170	140	22	20
IE3-W41R 315 L6 FAN	FF 600	508	110	590	610	494	508	120	-	624	216	373	80	70	M20	170	140	22	20
IE3-W41R 315 S8 FAN	FF 600	508	126	590	550	416	406	120	150	554	216	179	80	70	M20	170	140	22	20
IE3-W41R 315 M8 FAN	FF 600	508	110	590	610	494	457	120	150	554	216	234	80	70	M20	170	140	22	20
IE3-W41R 315 MX8 FAN	FF 600	508	110	590	610	494	457	120	-	573	216	304	80	70	M20	170	140	22	20
IE3-W41R 315 L8 FAN	FF 600	508	110	590	610	494	508	120	-	624	216	373	80	70	M20	170	140	22	20

¹⁾ Centre holes to DIN 332-DS

**Three-phase motors with squirrel-cage rotor for use in powered smoke and heat extraction systems to EN 12101-3
Energy-saving motors, Premium Efficiency IE3**

Surface cooling, type of cooling IC 418, degree of protection IP 55
Size 315

Type of construction IM B35 [IM 2001]

Flange dimensions, see page 8/23

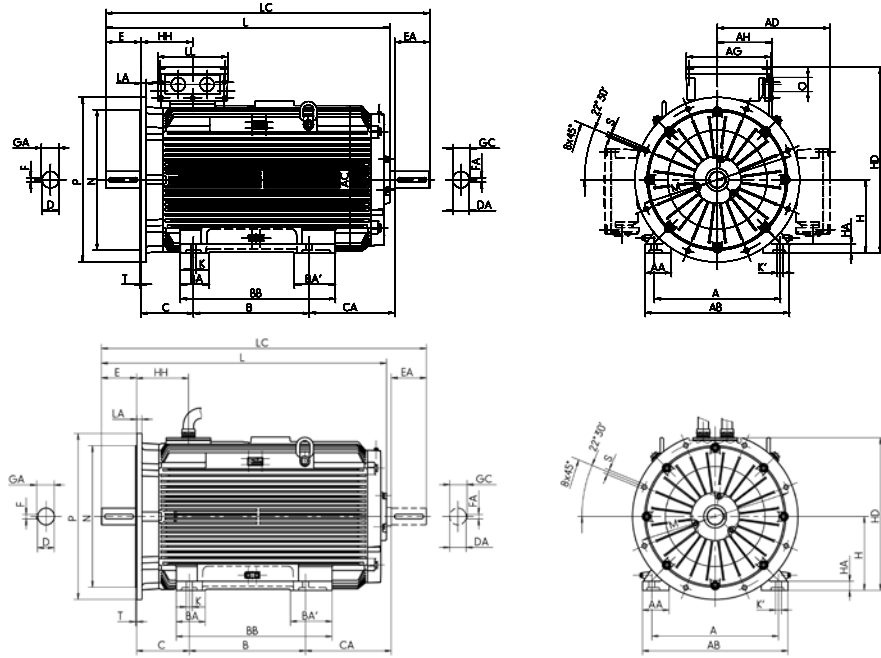

Type designation	GA	GC	H	HA	HD	HD** with TB	HD Cable	HH	K	K'	L	LC	TB Type	AG	LL	AH	O	BI
	t	t1	h	c	p	p	p	A	s	s'	k	k1		x	z	-	r	BI
IE3-W41R 315 S2 FAN	69	69	315	44	731	595	630	211	28	35	879	1026	200 A	282	242	-	M63 x 1.5	55
IE3-W41R 315 M2 FAN	69	69	315	44	731	595	630	211	28	35	934	1081	200 A	282	242	-	M63 x 1.5	55
IE3-W41R 315 MX2 FAN	69	69	315	44	809	628	663	230	28	35	1043	1187	400 B	415	340	265	M63 x 1.5	55
IE3-W41R 315 MY2 FAN	69	69	315	44	809	628	663	230	28	35	1113	1257	400 B	415	340	265	M63 x 1.5	55
IE3-W41R 315 L2 FAN	69	69	315	44	809	628	663	230	28	35	1233	1377	400 B	415	340	265	M63 x 1.5	55
IE3-W41R 315 LX2 FAN	69	69	315	44	809	628	663	230	28	35	1353	1497	400 B	415	340	265	M63 x 1.5	55
IE3-W41R 315 S4 FAN	85	74.5	315	44	731	595	630	211	28	35	909	1056	200 A	282	242	-	M63 x 1.5	55
IE3-W41R 315 M4 FAN	85	74.5	315	44	731	595	630	211	28	35	964	1111	200 A	282	242	-	M63 x 1.5	55
IE3-W41R 315 MX4 FAN	85	74.5	315	44	809	628	663	230	28	35	1073	1217	400 B	415	340	265	M63 x 1.5	55
IE3-W41R 315 MY4 FAN	85	74.5	315	44	809	628	663	230	28	35	1143	1287	400 B	415	340	265	M63 x 1.5	55
IE3-W41R 315 L4 FAN	85	74.5	315	44	809	628	663	230	28	35	1263	1407	400 B	415	340	265	M63 x 1.5	55
IE3-W41R 315 LX4 FAN	85	74.5	315	44	809	628	663	230	28	35	1383	1527	400 B	415	340	265	M63 x 1.5	55
IE3-W41R 315 S6 FAN	85	74.5	315	44	809	628	663	230	28	35	1073	1217	400 B	415	340	265	M63 x 1.5	55
IE3-W41R 315 M6 FAN	85	74.5	315	44	809	628	663	230	28	35	1143	1287	400 B	415	340	265	M63 x 1.5	55
IE3-W41R 315 MX6 FAN	85	74.5	315	44	809	628	663	230	28	35	1073	1217	400 B	415	340	265	M63 x 1.5	55
IE3-W41R 315 L6 FAN	85	74.5	315	44	809	628	663	230	28	35	1263	1407	400 B	415	340	265	M63 x 1.5	55
IE3-W41R 315 S8 FAN	85	74.5	315	44	731	595	630	211	28	35	964	1111	200 A	282	242	-	M63 x 1.5	55
IE3-W41R 315 M8 FAN	85	74.5	315	44	809	628	663	230	28	35	1073	1217	400 B	415	340	265	M63 x 1.5	55
IE3-W41R 315 MX8 FAN	85	74.5	315	44	809	628	663	230	28	35	1143	1287	400 B	415	340	265	M63 x 1.5	55
IE3-W41R 315 L8 FAN	85	74.5	315	44	809	628	663	230	28	35	1263	1407	400 B	415	340	265	M63 x 1.5	55

**) Terminal box left/right

**Three-phase motors with squirrel-cage rotor for use in powered smoke and heat extraction systems to EN 12101-3
Energy-saving motors, Premium Efficiency IE3**

Surface cooling, type of cooling IC 418, degree of protection IP 55
Size 355

Type of construction IM B3 [IM 1001]

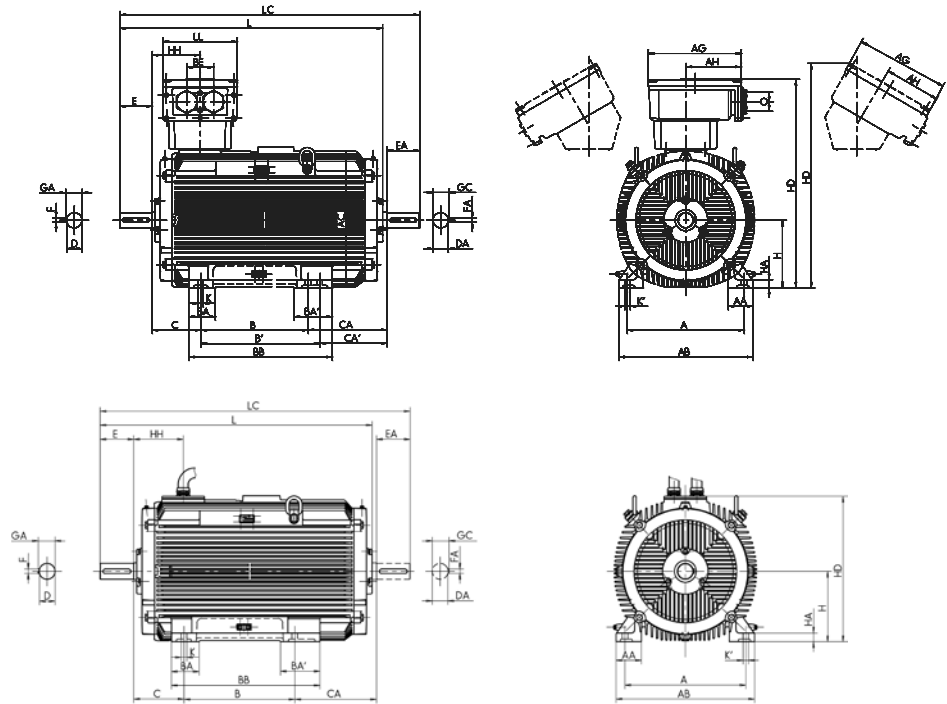

Type designation	Flange size	A	AA	AB	AC	B	BA	BA'	BB	C	CA	D	DA	DB'	E	EA	F	FA
		b	n	f	g	a	m	m1	e	w1	w2	d	d1		l	l1	u	u1
IE3-W41R 355 MY2 FAN	FF 740	610	130	700	715	560	140	200	750	254	404	80	80	M20	170	170	22	22
IE3-W41R 355 M2 FAN	FF 740	610	130	700	715	560	140	200	750	254	404	80	80	M20	170	170	22	22
IE3-W41R 355 MX2 FAN	FF 740	610	130	700	715	560	140	200	750	254	604	80	80	M20	170	170	22	22
IE3-W41R 355 L2 FAN	FF 740	610	130	700	715	630	140	200	750	254	611	80	80	M20	170	170	22	22
IE3-W41R 355 MY4 FAN	FF 740	610	130	700	715	560	140	200	750	254	534	100	80	M24	210	170	28	22
IE3-W41R 355 M 4 FAN	FF 740	610	130	700	715	560	140	200	750	254	404	100	80	M24	210	170	28	22
IE3-W41R 355 MX4 FAN	FF 740	610	130	700	715	560	140	200	750	254	604	100	80	M24	210	170	28	22
IE3-W41R 355 L4 FAN	FF 740	610	130	700	715	630	140	200	750	254	534	100	80	M24	210	170	28	22
IE3-W41R 355 MY6 FAN	FF 740	610	130	700	715	560	140	200	750	254	404	100	80	M24	210	170	28	22
IE3-W41R 355 M6 FAN	FF 740	610	130	700	715	560	140	200	750	254	404	100	80	M24	210	170	28	22
IE3-W41R 355 MX6 FAN	FF 740	610	130	700	715	560	140	200	750	254	604	100	80	M24	210	170	28	22
IE3-W41R 355 L6 FAN	FF 740	610	130	700	715	630	140	200	750	254	534	100	80	M24	210	170	28	22
IE3-W41R 355 LX6 FAN	FF 740	610	130	700	715	630	140	200	750	254	534	100	80	M24	210	170	28	22
IE3-W41R 355 MY8 FAN	FF 740	610	130	700	715	560	140	200	750	254	404	100	80	M24	210	170	28	22
IE3-W41R 355 M8 FAN	FF 740	610	130	700	715	560	140	200	750	254	404	100	80	M24	210	170	28	22
IE3-W41R 355 MX8 FAN	FF 740	610	130	700	715	560	140	200	750	254	604	100	80	M24	210	170	28	22
IE3-W41R 355 L8 FAN	FF 740	610	130	700	715	630	140	200	750	254	534	100	80	M24	210	170	28	22
IE3-W41R 355 LX8 FAN	FF 740	610	130	700	715	630	140	200	750	254	534	100	80	M24	210	170	28	22

¹ Centre holes to DIN 332-DS

Three-phase motors with squirrel-cage rotor for use in powered smoke and heat extraction systems to EN 12101-3 Energy-saving motors, Premium Efficiency IE3

Surface cooling, type of cooling IC 418, degree of protection IP 55
Size 355

Type of construction IM B35 [IM 1001]

Flange dimensions, see page 8/23

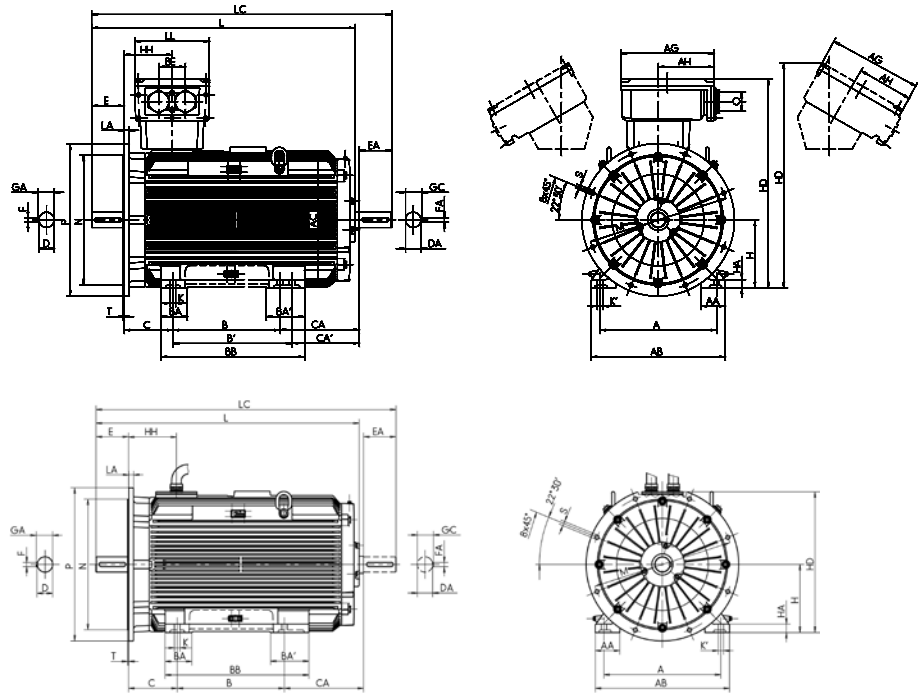

Type designation	GA	GC	H	HA	HD	HD ^{*)}	HD	HH	K	K'	L	LC	TB Type	AG	LL	AH	BE	O	BI
	t	t1	h	c	p	p	p	A	s	s'	k	k1	x	z	-	-	r	BI	
IE3-W41R 355 MY2 FAN	85	85	355	44	1091	1172	839	250	28	35	1365	1558	630 A	496	390	301	140	M72 x 2	60
IE3-W41R 355 M2 FAN	85	85	355	44	1091	1172	839	250	28	35	1365	1558	630 A	496	390	301	140	M72 x 2	60
IE3-W41R 355 MX2 FAN	85	85	355	44	1083	1174	839	327	28	35	1565	1758	1000 A	615	474	385	200	M72 x 2	60
IE3-W41R 355 L2 FAN	85	85	355	44	1083	1174	839	327	28	35	1565	1758	1000 A	615	474	385	200	M72 x 2	60
IE3-W41R 355 MY4 FAN	106	85	355	44	1091	1172	839	250	28	35	1405	1598	630 A	496	390	301	140	M72 x 2	60
IE3-W41R 355 M 4 FAN	106	85	355	44	1091	1172	839	250	28	35	1405	1598	630 A	496	390	301	140	M72 x 2	60
IE3-W41R 355 MX4 FAN	106	85	355	44	1091	1172	839	250	28	35	1605	1798	630 A	496	390	301	140	M72 x 2	60
IE3-W41R 355 L4 FAN	106	85	355	44	1083	1174	839	327	28	35	1605	1798	1000 A	615	474	385	200	M72 x 2	60
IE3-W41R 355 MY6 FAN	106	85	355	44	1091	1172	839	250	28	35	1405	1598	630 A	496	390	301	140	M72 x 2	60
IE3-W41R 355 M6 FAN	106	85	355	44	1091	1172	839	250	28	35	1405	1598	630 A	496	390	301	140	M72 x 2	60
IE3-W41R 355 MX6 FAN	106	85	355	44	1091	1172	839	250	28	35	1605	1798	630 A	496	390	301	140	M72 x 2	60
IE3-W41R 355 L 6 FAN	106	85	355	44	1083	1174	839	327	28	35	1605	1798	1000 A	615	474	385	200	M72 x 2	60
IE3-W41R 355 LX6 FAN	106	85	355	44	1083	1174	839	327	28	35	1605	1798	1000 A	615	474	385	200	M72 x 2	60
IE3-W41R 355 MY8 FAN	106	85	355	44	1091	1172	839	250	28	35	1405	1598	630 A	496	390	301	140	M72 x 2	60
IE3-W41R 355 M8 FAN	106	85	355	44	1091	1172	839	250	28	35	1405	1598	630 A	496	390	301	140	M72 x 2	60
IE3-W41R 355 MX8 FAN	106	85	355	44	1091	1172	839	250	28	35	1605	1798	630 A	496	390	301	140	M72 x 2	60
IE3-W41R 355 L8 FAN	106	85	355	44	1083	1174	839	327	28	35	1605	1798	1000 A	615	474	385	200	M72 x 2	60
IE3-W41R 355 LX8 FAN	106	85	355	44	1083	1174	839	327	28	35	1605	1798	1000 A	615	474	385	200	M72 x 2	60

^{*)} Terminal box inclined left/right

Three-phase motors with squirrel-cage rotor for use in powered smoke and heat extraction systems to EN 12101-3 Energy-saving motors, Premium Efficiency IE3

Surface cooling, type of cooling IC 418, degree of protection IP 55
Size 132 to 160

Type of construction IM B14 [IM 3601]

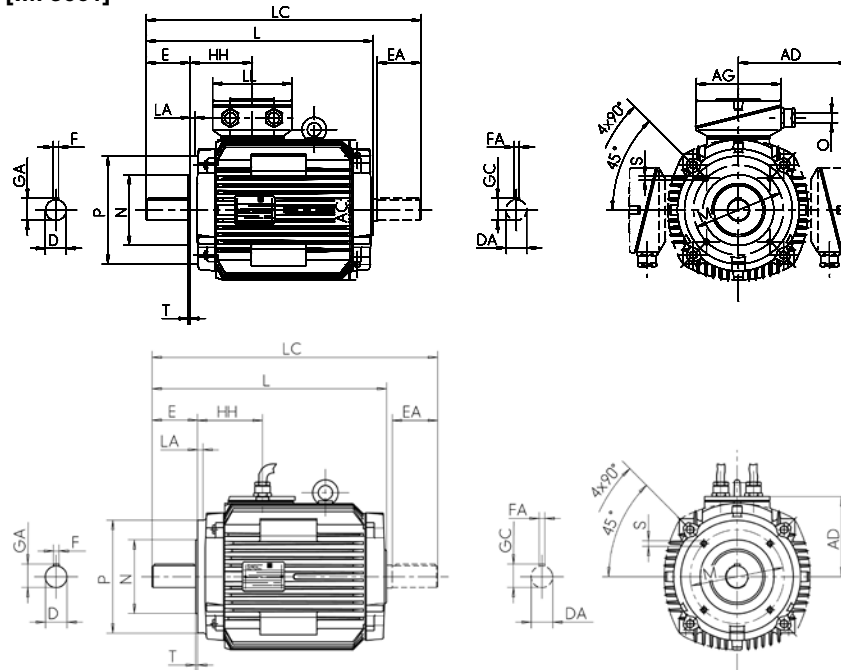

Type designation	Flange size	A	AA	AB	AC	AD	B	BA	BA'	BB	C	CA	D	DA	DB ¹⁾	E	EA	F	FA
		b	n	f	g	g1	a	m	m1	e	w1	w2	d	d1		l	l1	u	u1
IE3-W41R 132 SX2 FAN	FT 165	FT 215	216	50	256	258	199	140	53	180	89	117	38	32	M12	80	80	10	10
IE3-W41R 132 S4 FAN	FT 165	FT 215	216	50	256	258	199	140	53	180	89	165	38	32	M12	80	80	10	10
IE3-W41R 132 M4 FAN	FT 165	FT 215	216	50	256	258	199	178	53	218	89	177	38	38	M12	80	80	10	10
IE3-W41R 132 M6 FAN	FT 165	FT 215	216	50	256	258	199	178	53	218	89	79	38	32	M12	80	80	10	10
IE3-W41R 132 MX6 FAN	FT 165	FT 215	216	50	256	258	199	178	53	218	89	177	38	38	M12	80	80	10	10
IE3-W41R 132 S8 FAN	FT 165	FT 215	216	50	256	258	199	140	53	180	89	117	38	32	M12	80	80	10	10
IE3-W41R 132 M8 FAN	FT 165	FT 215	216	50	256	258	199	178	53	218	89	79	38	32	M12	80	80	10	10
IE3-W41R 160 M2 FAN	FT 215	C300	254	55	296	313	242	210	60	257	108	87	42	42	M16	110	110	12	12
IE3-W41R 160 MX2 FAN	FT 215	C300	254	55	296	313	242	210	56	257	108	125	42	42	M16	110	110	12	12
IE3-W41R 160 L2 FAN	FT 215	C300	254	55	296	313	242	254	60	301	108	131	42	42	M16	110	110	12	12
IE3-W41R 160 M4 FAN	FT 215	C300	254	55	296	313	242	210	60	257	108	87	42	42	M16	110	110	12	12
IE3-W41R 160 L4C FAN	FT 215	C300	254	55	296	313	242	254	60	301	108	131	42	42	M16	110	110	12	12
IE3-W41R 160 M6 FAN	FT 215	C300	254	55	296	313	242	210	56	257	108	125	42	42	M16	110	110	12	12
IE3-W41R 160 L6C FAN	FT 215	C300	254	55	296	313	242	254	60	301	108	131	42	42	M16	110	110	12	12
IE3-W41R 160 M8 FAN	FT 215	C300	254	55	296	313	242	210	60	257	108	87	42	42	M16	110	110	12	12
IE3-W41R 160 MX8 FAN	FT 215	C300	254	55	296	313	242	210	56	257	108	125	42	42	M16	110	110	12	12
IE3-W41R 160 L8 FAN	FT 215	C300	254	55	296	313	242	254	60	301	108	131	42	42	M16	110	110	12	12

¹⁾ Centre holes to DIN 332-DS

Three-phase motors with squirrel-cage rotor for use in powered smoke and heat extraction systems to EN 12101-3 Energy-saving motors, Premium Efficiency IE3

Surface cooling, type of cooling IC 418, degree of protection IP 55
Size 132 to 160

Type of construction IM B34 [IM 2101]

Flange dimensions, see page 8/23

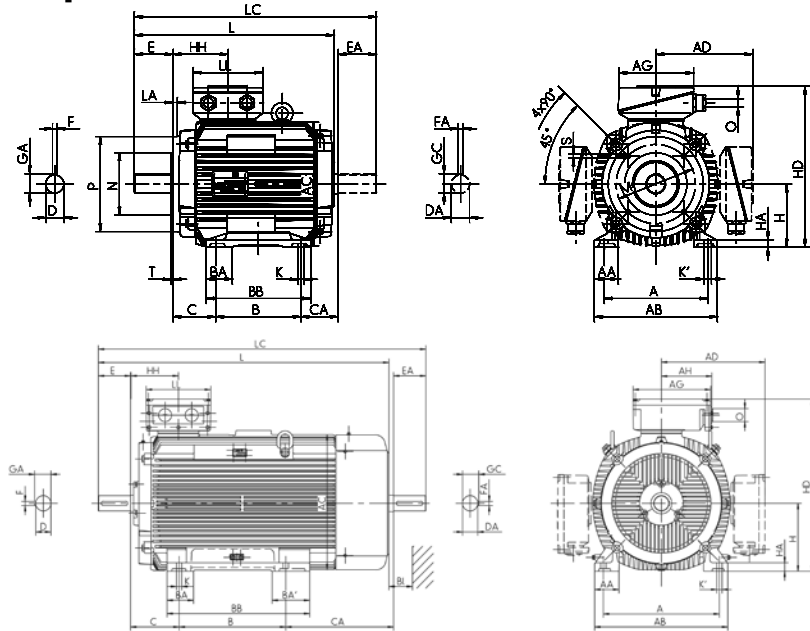

Type designation	GA	GC	H	HA	HD	HD** with TB	HD Cable	HH	K	K'	L	LC	TB Type	AG	LL	AH	O	BI
	t	t1	h	c	p	p	p	A	s	s'	k	k1		x	z	-	r	BI
IE3-W41R 132 SX2 FAN	41	35	132	15	331	279	276	114	12	12	424	506	25 A	156	145	M32 x 1.5	4L	35
IE3-W41R 132 S4 FAN	41	35	132	15	331	279	276	114	12	12	472	554	25 A	156	145	M32 x 1.5	4L	35
IE3-W41R 132 M4 FAN	41	41	132	15	331	279	276	114	12	12	522	604	25 A	156	145	M32 x 1.5	4L	35
IE3-W41R 132 M6 FAN	41	35	132	16	331	279	276	114	12	12	424	506	25 A	156	145	M32 x 1.5	4L	35
IE3-W41R 132 MX6 FAN	41	41	132	15	331	279	276	114	12	12	522	604	25 A	156	145	M32 x 1.5	4L	35
IE3-W41R 132 S8 FAN	41	35	132	16	331	279	276	114	12	12	424	506	25 A	156	145	M32 x 1.5	4L	35
IE3-W41R 132 M8 FAN	41	35	132	16	331	279	276	114	12	12	424	506	25 A	156	145	M32 x 1.5	4L	35
IE3-W41R 160 M2 FAN	45	45	160	18	402	336	332	138	15	20	512	625	63 A	193	167	M40 x 1.5	4L	35
IE3-W41R 160 MX2 FAN	45	45	160	18	402	336	332	138	15	20	550	663	63 A	193	167	M40 x 1.5	4L	35
IE3-W41R 160 L2 FAN	45	45	160	18	402	336	332	138	15	20	600	713	63 A	193	167	M40 x 1.5	4L	35
IE3-W41R 160 M4 FAN	45	45	160	18	402	336	332	138	15	20	512	625	63 A	193	167	M40 x 1.5	4L	35
IE3-W41R 160 L4C FAN	45	45	160	18	402	336	332	138	15	20	600	713	63 A	193	167	M40 x 1.5	4L	35
IE3-W41R 160 M6 FAN	45	45	160	18	402	336	332	138	15	20	550	663	63 A	193	167	M40 x 1.5	4L	35
IE3-W41R 160 L6C FAN	45	45	160	18	402	336	332	138	15	20	600	713	63 A	193	167	M40 x 1.5	4L	35
IE3-W41R 160 M8 FAN	45	45	160	18	402	336	332	138	15	20	512	625	63 A	193	167	M40 x 1.5	4L	35
IE3-W41R 160 MX8 FAN	45	45	160	18	402	336	332	138	15	20	550	663	63 A	193	167	M40 x 1.5	4L	35
IE3-W41R 160 L8 FAN	45	45	160	18	402	336	332	138	15	20	600	713	63 A	193	167	M40 x 1.5	4L	35

**) Terminal box left/right

Three-phase motors with squirrel-cage rotor for use in powered smoke and heat extraction systems to EN 12101-3
Energy-saving motors, Premium Efficiency IE3

Surface cooling, type of cooling IC 418, degree of protection IP 55
 Size 132 to 280

Type of construction IM B5 [IM 3001]
Type of construction IM V1 [IM 3011]

Flange dimensions, see page 8/23

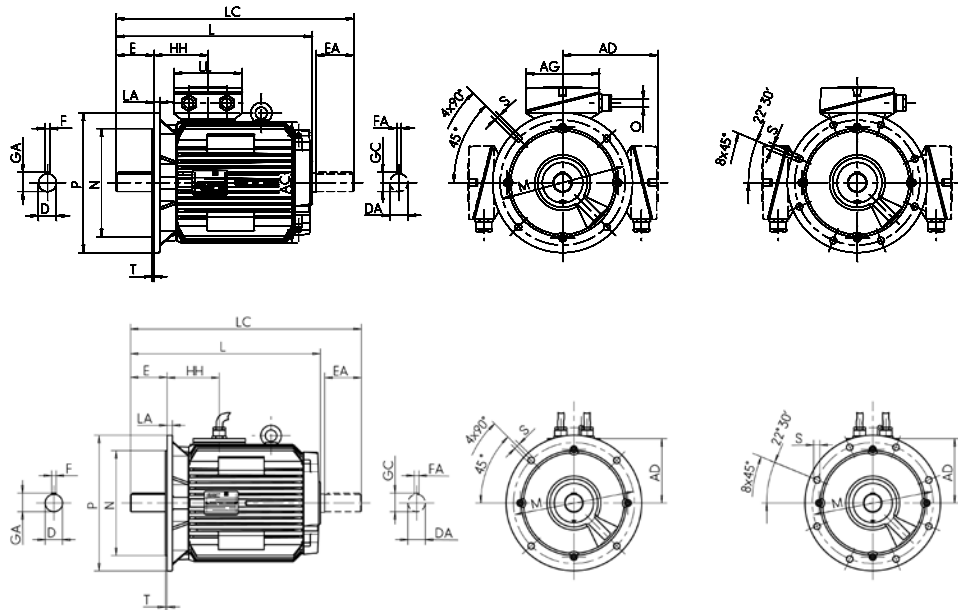

Type designation	Flange size	AC	AD	AD	D	DA	DB ¹⁾	E	EA	F	FA	GA	GC	H	HH	L	LC	TB Type	AG	LL	O	Hole	BI
		g	g1	g1	d	d1		l	l1	u	u1	t	t1	h	A	k	k1		x	z	-	pattern	BI
IE3-W41R 132 SX2 FAN	FF 265	258	199	144	38	32	M12	80	80	10	10	41	35	132	114	424	506	25 A	156	145	M32 x 1.5	4L	35
IE3-W41R 132 S4 FAN	FF 265	258	199	144	38	32	M12	80	80	10	10	41	35	132	114	472	554	25 A	156	145	M32 x 1.5	4L	35
IE3-W41R 132 M4 FAN	FF 265	258	199	144	38	38	M12	80	80	10	10	41	41	132	114	522	604	25 A	156	145	M32 x 1.5	4L	35
IE3-W41R 132 M6 FAN	FF 265	258	199	144	38	32	M12	80	80	10	10	41	35	132	114	424	506	25 A	156	145	M32 x 1.5	4L	35
IE3-W41R 132 MX6 FAN	FF 265	258	199	144	38	38	M12	80	80	10	10	41	41	132	114	522	604	25 A	156	145	M32 x 1.5	4L	35
IE3-W41R 132 S8 FAN	FF 265	258	199	144	38	32	M12	80	80	10	10	41	35	132	114	424	506	25 A	156	145	M32 x 1.5	4L	35
IE3-W41R 132 M8 FAN	FF 265	258	199	144	38	32	M12	80	80	10	10	41	35	132	114	424	506	25 A	156	145	M32 x 1.5	4L	35
IE3-W41R 160 M2 FAN	FF 300	313	242	172	42	42	M16	110	110	12	12	45	45	160	138	512	625	63 A	193	167	M40 x 1.5	4L	35
IE3-W41R 160 MX2 FAN	FF 300	313	242	172	42	42	M16	110	110	12	12	45	45	160	138	550	663	63 A	193	167	M40 x 1.5	4L	35
IE3-W41R 160 L2 FAN	FF 300	313	242	172	42	42	M16	110	110	12	12	45	45	160	138	600	713	63 A	193	167	M40 x 1.5	4L	35
IE3-W41R 160 M4 FAN	FF 300	313	242	172	42	42	M16	110	110	12	12	45	45	160	138	512	625	63 A	193	167	M40 x 1.5	4L	35
IE3-W41R 160 L4C FAN	FF 300	313	242	172	42	42	M16	110	110	12	12	45	45	160	138	600	713	63 A	193	167	M40 x 1.5	4L	35
IE3-W41R 160 M6 FAN	FF 300	313	242	172	42	42	M16	110	110	12	12	45	45	160	138	550	663	63 A	193	167	M40 x 1.5	4L	35
IE3-W41R 160 L6C FAN	FF 300	313	242	172	42	42	M16	110	110	12	12	45	45	160	138	600	713	63 A	193	167	M40 x 1.5	4L	35
IE3-W41R 160 M8 FAN	FF 300	313	242	172	42	42	M16	110	110	12	12	45	45	160	138	512	625	63 A	193	167	M40 x 1.5	4L	35
IE3-W41R 160 MX8 FAN	FF 300	313	242	172	42	42	M16	110	110	12	12	45	45	160	138	550	663	63 A	193	167	M40 x 1.5	4L	35
IE3-W41R 160 L8 FAN	FF 300	313	242	172	42	42	M16	110	110	12	12	45	45	160	138	600	713	63 A	193	167	M40 x 1.5	4L	35
IE3-W41R 180 M2C FAN	FF 300	351	261	191	48	48	M16	110	110	14	14	51.5	51.5	180	147	625	734	63 A	193	167	M40 x 1.5	4L	35
IE3-W41R 180 M4 FAN	FF 300	351	261	191	48	48	M16	110	110	14	14	51.5	51.5	180	147	625	734	63 A	193	167	M40 x 1.5	4L	35
IE3-W41R 180 L4 FAN	FF 300	351	261	191	48	48	M16	110	110	14	14	51.5	51.5	180	147	675	784	63 A	193	167	M40 x 1.5	4L	35
IE3-W41R 180 L6C FAN	FF 300	351	261	191	48	48	M16	110	110	14	14	51.5	51.5	180	147	625	734	63 A	193	167	M40 x 1.5	4L	35
IE3-W41R 180 L8 FAN	FF 300	351	261	191	48	48	M16	110	110	14	14	51.5	51.5	180	147	625	734	63 A	193	167	M40 x 1.5	4L	35
IE3-W41R 200 L2 FAN	FF 350	390	300	211	55	55	M20	110	110	16	16	59	59	200	168	698	805	100 A	213	207	M50 x 1.5	4L	40
IE3-W41R 200 LX2C FAN	FF 350	390	300	211	55	55	M20	110	110	16	16	59	59	200	168	698	805	100 A	213	207	M50 x 1.5	4L	40
IE3-W41R 200 L4C FAN	FF 350	390	300	211	55	55	M20	110	110	16	16	59	59	200	168	698	805	100 A	213	207	M50 x 1.5	4L	35
IE3-W41R 200 L6 FAN	FF 350	390	300	211	55	55	M20	110	110	16	16	59	59	200	168	698	805	100 A	213	207	M50 x 1.5	4L	35
IE3-W41R 200 LX6C FAN	FF 350	390	300	211	55	55	M20	110	110	16	16	59	59	200	168	698	805	100 A	213	207	M50 x 1.5	4L	35
IE3-W41R 200 L8 FAN	FF 350	351	261	191	55	48	M20	110	110	16	14	59	51.5	200	147	675	784	63 A	193	167	M50 x 1.5	4L	35
IE3-W41R 225 M2 FAN	FF 400	440	324	235	60	55	M20	110	110	16	16	59	59	225	177	707	827	100 A	213	207	M50 x 1.5	8L	45
IE3-W41R 225 S4C FAN	FF 400	390	300	211	60	55	M20	140	110	18	16	64	59	225	168	778	885	100 A	213	207	M50 x 1.5	8L	40
IE3-W41R 225 M4 FAN	FF 400	440	324	235	60	55	M20	140	110	18	16	64	59	225	177	787	907	100 A	213	207	M50 x 1.5	8L	45
IE3-W41R 225 M6 FAN	FF 400	440	324	235	60	55	M20	140	110	18	16	64	59	225	177	787	907	100 A	213	207	M50 x 1.5	8L	45
IE3-W41R 225 S8 FAN	FF 400	390	300	211	60	55	M20	140	110	18	16	64	59	225	168	728	835	100 A	213	207	M50 x 1.5	8L	40
IE3-W41R 225 M8 FAN	FF 400	440	324	235	60	55	M20	140	110	18	16	64	59	225	177	737	857	100 A	213	207	M50 x 1.5	8L	45

Type designation	Flange size	AC	AD	AD	D	DA	DB ¹⁾	E	EA	F	FA	GA	GC	H	HH	L	LC	TB	AG	LL	O	Hole	BI
		g	g1	g1	d	d1	l	l1	u	u1	t	t1	h	A	k	k1	x	z	-	pattern	BI		
IE3-W41R 250 M2 FAN	FF 500	490	386	285	60	55	M20	140	110	18	16	64	59	250	206	801	921	200 A	282	242	M63 x 1.5	8L	55
IE3-W41R 250 M4 FAN	FF 500	490	386	285	65	55	M20	140	110	18	16	69	59	250	206	801	921	200 A	282	242	M63 x 1.5	8L	50
IE3-W41R 250 M6 FAN	FF 500	490	386	285	65	55	M20	140	110	18	16	69	59	250	206	801	921	200 A	282	242	M63 x 1.5	8L	50
IE3-W41R 250 M8 FAN	FF 500	440	386	235	65	55	M20	140	110	18	16	69	59	250	206	787	907	100 A	282	242	M50 x 1.5	8L	50
IE3-W41R 280 S2 FAN	FF 500	490	386	285	65	65	M20	140	140	18	18	69	69	280	206	801	951	200 A	282	242	M63 x 1.5	8L	55
IE3-W41R 280 M2 FAN	FF 500	490	386	285	65	65	M20	140	140	18	18	69	69	280	206	848	998	200 A	282	242	M63 x 1.5	8L	55
IE3-W41R 280 S4 FAN	FF 500	490	386	285	75	65	M20	140	140	20	18	79.5	69	280	206	848	998	200 A	282	242	M63 x 1.5	8L	50
IE3-W41R 280 M4 FAN	FF 500	550	416	315	75	65	M20	140	140	20	18	79.5	69	280	211	934	1081	200 A	282	242	M63 x 1.5	8L	55
IE3-W41R 280 S6 FAN	FF 500	550	416	315	75	65	M20	140	140	20	18	79.5	69	280	211	879	1026	200 A	282	242	M63 x 1.5	8L	55
IE3-W41R 280 M6 FAN	FF 500	550	416	315	75	65	M20	140	140	20	18	79.5	69	280	211	934	1081	200 A	282	242	M63 x 1.5	8L	55
IE3-W41R 280 S8 FAN	FF 500	490	386	285	75	65	M20	140	140	20	18	79.5	69	280	206	801	951	200 A	282	242	M63 x 1.5	8L	55
IE3-W41R 280 M8 FAN	FF 500	550	416	315	75	65	M20	140	140	20	18	79.5	69	280	211	934	1081	200 A	282	242	M63 x 1.5	8L	55

¹⁾ Centre holes to DIN 332-DS

^{**)} Terminal box left/right

**Three-phase motors with squirrel-cage rotor for use in powered smoke and heat extraction systems to EN 12101-3
Energy-saving motors, Premium Efficiency IE3**

Surface cooling, type of cooling IC 418, degree of protection IP 55
Size 315

**Type of construction IM B5 [IM 3001]
Type of construction IM V1 [IM 3011]**

Flange dimensions, see page 8/23

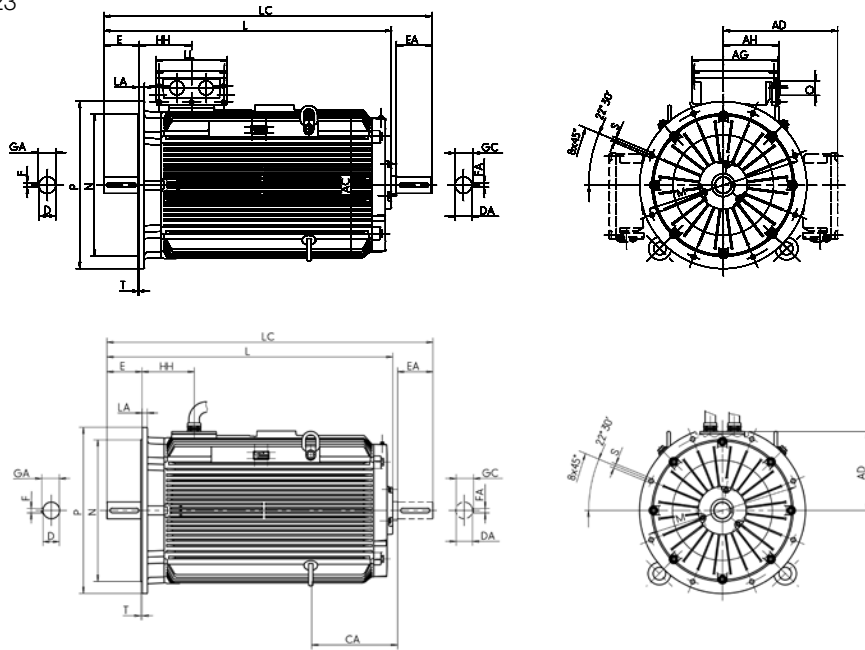

Type designation	Flange size	AC	AD	AD	D	DA	DB ¹⁾	E	EA	F	FA	GA	GC	H	HH	L	LC	TB	Type	AG	LL	AH	O	BI
		g	g1	g	d	d1		l	l1	u	u1	t	t1	h	A	k	k1	x	z	-	r	BI		
IE3-W41R 315 S2	FF 600	550	416	315	65	65	M20	140	140	18	18	69	69	315	211	879	1026	200	A	282	242	-	M63 x 1.5	55
IE3-W41R 315 M2	FF 600	550	416	315	65	65	M20	140	140	18	18	69	69	315	211	934	1081	200	A	282	242	-	M63 x 1.5	55
IE3-W41R 315 MX2	FF 600	610	494	348	65	65	M20	140	140	18	18	69	69	315	230	1043	1187	400	B	415	340	265	M63 x 1.5	55
IE3-W41R 315 MY2	FF 600	610	494	348	65	65	M20	140	140	18	18	69	69	315	230	1113	1257	400	B	415	340	265	M63 x 1.5	55
IE3-W41R 315 L2	FF 600	610	494	348	65	65	M20	140	140	18	18	69	69	315	230	1233	1377	400	B	415	340	265	M63 x 1.5	55
IE3-W41R 315 LX2	FF 600	610	494	348	65	65	M20	140	140	18	18	69	69	315	230	1353	1497	400	B	415	340	265	M63 x 1.5	55
IE3-W41R 315 S4	FF 600	550	416	315	80	70	M20	170	140	22	20	85	74.5	315	211	909	1056	200	A	282	242	-	M63 x 1.5	55
IE3-W41R 315 M4	FF 600	550	416	315	80	70	M20	170	140	22	20	85	74.5	315	211	964	1111	200	A	282	242	-	M63 x 1.5	55
IE3-W41R 315 MX4	FF 600	610	494	348	80	70	M20	170	140	22	20	85	74.5	315	230	1073	1217	400	B	415	340	265	M63 x 1.5	55
IE3-W41R 315 MY4	FF 600	610	494	348	80	70	M20	170	140	22	20	85	74.5	315	230	1143	1287	400	B	415	340	265	M63 x 1.5	55
IE3-W41R 315 L4	FF 600	610	494	348	80	70	M20	170	140	22	20	85	74.5	315	230	1263	1407	400	B	415	340	265	M63 x 1.5	55
IE3-W41R 315 LX4	FF 600	610	494	348	80	70	M20	170	140	22	20	85	74.5	315	230	1383	1527	400	B	415	340	265	M63 x 1.5	55
IE3-W41R 315 S6	FF 600	610	494	348	80	70	M20	170	140	22	20	85	74.5	315	230	1073	1217	400	B	415	340	265	M63 x 1.5	55
IE3-W41R 315 M6	FF 600	610	494	348	80	70	M20	170	140	22	20	85	74.5	315	230	1143	1287	400	B	415	340	265	M63 x 1.5	55
IE3-W41R 315 MX6	FF 600	610	494	348	80	70	M20	170	140	22	20	85	74.5	315	230	1073	1217	400	B	415	340	265	M63 x 1.5	55
IE3-W41R 315 L6	FF 600	610	494	348	80	70	M20	170	140	22	20	85	74.5	315	230	1263	1407	400	B	415	340	265	M63 x 1.5	55
IE3-W41R 315 S8	FF 600	550	416	315	80	70	M20	170	140	22	20	85	74.5	315	211	964	1111	200	A	282	242	-	M63 x 1.5	55
IE3-W41R 315 M8	FF 600	610	494	348	80	70	M20	170	140	22	20	85	74.5	315	230	1073	1217	400	B	415	340	265	M63 x 1.5	55
IE3-W41R 315 MX8	FF 600	610	494	348	80	70	M20	170	140	22	20	85	74.5	315	230	1143	1287	400	B	415	340	265	M63 x 1.5	55
IE3-W41R 315 L8	FF 600	610	494	348	80	70	M20	170	140	22	20	85	74.5	315	230	1263	1407	400	B	415	340	265	M63 x 1.5	55

¹⁾ Centre holes to DIN 332-DS

Three-phase motors with squirrel-cage rotor for use in powered smoke and heat extraction systems to EN 12101-3 Energy-saving motors, Premium Efficiency IE3

Surface cooling, type of cooling IC 418, degree of protection IP 55
Size 355

Type of construction IM B5 [IM 3001]
Type of construction IM V1 [IM 3011]

Flange dimensions, see page 8/23

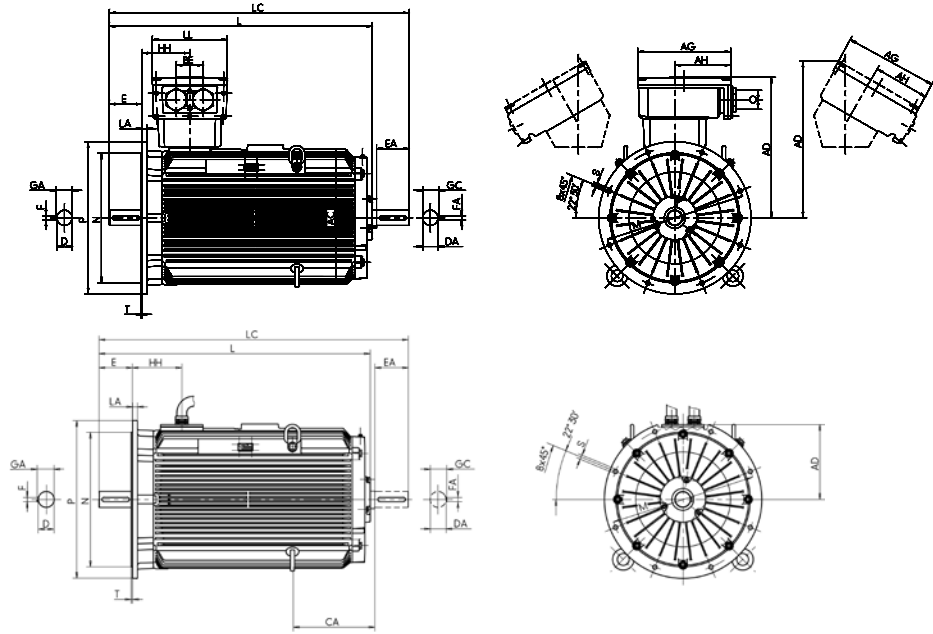

Type designation	Flange size	AC	AD	AD ^{*)}	AD	D	DA	DB ^{*)}	E	EA	F	FA	GA	GC	H	HH	L	LC	TB Type	AG	LL	AH	BE	O	BI
		g	g1	g1	g1	d	d1		l	l1	u	u1	t	t1	h	A	K	K1		x	z	-	-	r	Bl
IE3-W41R 355 MY2	FF 740	715	736	817	484	80	80	M20	170	170	22	22	85	85	355	250	1365	1558	630 A	496	390	301	140	M72 x 2	60
IE3-W41R 355 M2	FF 740	715	736	817	484	80	80	M20	170	170	22	22	85	85	355	250	1365	1558	630 A	496	390	301	140	M72 x 2	60
IE3-W41R 355 MX2	FF 740	715	728	819	484	80	80	M20	170	170	22	22	85	85	355	327	1565	1758	1000 A	615	474	385	200	M72 x 2	60
IE3-W41R 355 L2	FF 740	715	728	819	484	80	80	M20	170	170	22	22	85	85	355	327	1565	1758	1000 A	615	474	385	200	M72 x 2	60
IE3-W41R 355 MY4	FF 740	715	736	817	484	100	80	M24	210	170	28	22	106	85	355	250	1405	1598	630 A	496	390	301	140	M72 x 2	60
IE3-W41R 355 M4	FF 740	715	736	817	484	100	80	M24	210	170	28	22	106	85	355	250	1405	1598	630 A	496	390	301	140	M72 x 2	60
IE3-W41R 355 MX4	FF 740	715	736	817	484	100	80	M24	210	170	28	22	106	85	355	250	1605	1798	630 A	496	390	301	140	M72 x 2	60
IE3-W41R 355 L4	FF 740	715	728	819	484	100	80	M24	210	170	28	22	106	85	355	327	1605	1798	1000 A	615	474	385	200	M72 x 2	60
IE3-W41R 355 MY6	FF 740	715	736	817	484	100	80	M24	210	170	28	22	106	85	355	250	1405	1598	630 A	496	390	301	140	M72 x 2	60
IE3-W41R 355 M6	FF 740	715	736	817	484	100	80	M24	210	170	28	22	106	85	355	250	1405	1598	630 A	496	390	301	140	M72 x 2	60
IE3-W41R 355 MX6	FF 740	715	736	817	484	100	80	M24	210	170	28	22	106	85	355	250	1605	1798	630 A	496	390	301	140	M72 x 2	60
IE3-W41R 355 L6	FF 740	715	728	819	484	100	80	M24	210	170	28	22	106	85	355	327	1605	1798	1000 A	615	474	385	200	M72 x 2	60
IE3-W41R 355 LX6	FF 740	715	728	819	484	100	80	M24	210	170	28	22	106	85	355	327	1605	1798	1000 A	615	474	385	200	M72 x 2	60
IE3-W41R 355 MY8	FF 740	715	736	817	484	100	80	M24	210	170	28	22	106	85	355	250	1405	1598	630 A	496	390	301	140	M72 x 2	60
IE3-W41R 355 M8	FF 740	715	736	817	484	100	80	M24	210	170	28	22	106	85	355	250	1405	1598	630 A	496	390	301	140	M72 x 2	60
IE3-W41R 355 MX8	FF 740	715	736	817	484	100	80	M24	210	170	28	22	106	85	355	250	1605	1798	630 A	496	390	301	140	M72 x 2	60
IE3-W41R 355 L8	FF 740	715	728	819	484	100	80	M24	210	170	28	22	106	85	355	327	1605	1798	1000 A	615	474	385	200	M72 x 2	60
IE3-W41R 355 LX8	FF 740	715	728	819	484	100	80	M24	210	170	28	22	106	85	355	327	1605	1798	1000 A	615	474	385	200	M72 x 2	60

^{*)} Centre holes to DIN 332-DS

^{**)} Terminal box left/right

Three-phase motors with squirrel-cage rotor for use in powered smoke and heat extraction systems to EN 12101-3
Energy-saving motors, High Efficiency IE2

Surface cooling, type of cooling IC 418, degree of protection IP 55
 Size 132 to 225

Type of construction IM B3 [IM 1001]

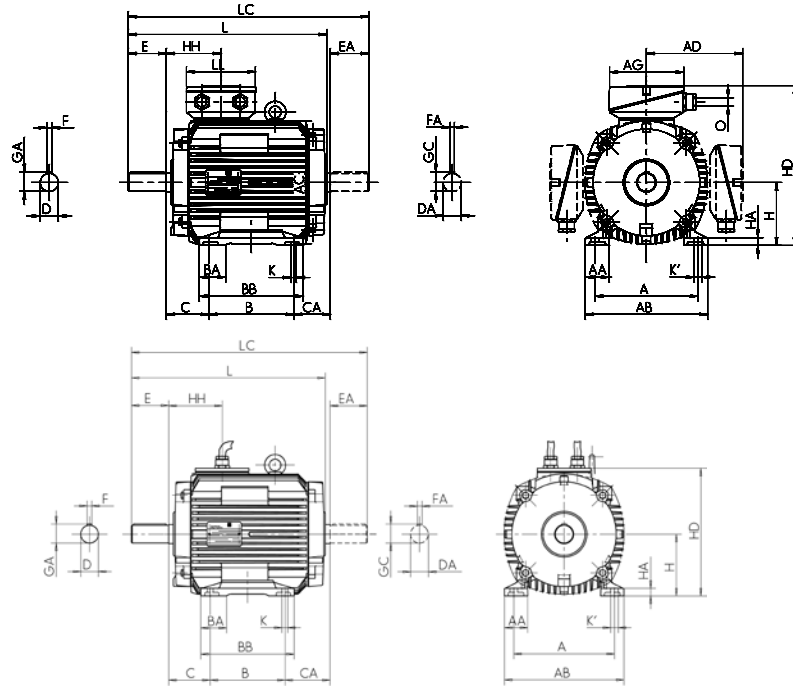

Type designation	Flange size	A	AA	AB	AC	AD	B	BA	BB	C	CA	D	DA	DB ¹⁾	E	EA	F	FA
		b	n	f	g	g1	a	m	e	w1	w2	d	d1	l	l1	u	u1	
IE2-WE2R 132 S4 FAN	FF 265	216	50	256	217	178	140	53	180	89	167	38	32	M12	80	80	10	10
IE2-WE1R 132 SX2 FAN	FF 265	216	50	256	258	199	140	53	180	89	117	38	38	M12	80	80	10	10
IE2-WE1R 132 M4 FAN	FF 265	216	50	256	258	199	178	53	218	89	127	38	38	M12	80	80	10	10
IE2-WE1R 132 MX6 FAN	FF 265	216	50	256	258	199	178	53	218	89	127	38	38	M12	80	80	10	10
IE2-WE2R 132 M6, 8 FAN	FF 265	216	50	256	217	178	178	53	218	89	129	38	32	M12	80	80	10	10
IE2-WE1R 160 M2 FAN	FF 300	254	55	296	313	242	210	60	257	108	87	42	42	M16	110	110	12	12
IE2-WE1R 160 M4 FAN	FF 300	254	55	296	313	242	210	60	257	108	87	42	42	M16	110	110	12	12
IE2-WE2R 160 M4 FAN	FF 300	254	55	296	258	214	210	60	257	108	126	42	38	M16	110	80	12	10
IE2-WE1R 160 M8 FAN	FF 300	254	55	296	258	214	210	60	257	108	76	42	38	M16	110	80	12	10
IE2-WE1R 160 M6, MX8 FAN	FF 300	254	55	296	313	242	210	60	257	108	87	42	42	M16	110	110	12	12
IE2-WE2R 160 M6, MX8 FAN	FF 300	254	55	296	258	214	210	60	257	108	126	42	38	M16	110	80	12	10
IE2-WE1R 160 MX2 FAN	FF 300	254	55	296	313	242	210	56	257	108	125	42	42	M16	110	110	12	12
IE2-WE1R 160 L2 FAN	FF 300	254	55	296	313	242	254	60	301	108	81	42	42	M16	110	110	12	12
IE2-WE2R 160 L4 FAN	FF 300	254	55	296	313	242	254	60	301	108	131	42	42	M16	110	110	12	12
IE2-WE1R 160 L6, 8 FAN	FF 300	254	55	296	313	242	254	60	301	108	81	42	42	M16	110	110	12	12
IE2-WE1R 180 M2 FAN	FF 300	279	62	328	351	261	241	65	288	121	107	48	48	M16	110	110	14	14
IE2-WE1R 180 M4 FAN	FF 300	279	62	328	351	261	241	65	288	121	152	48	48	M16	110	110	14	14
IE2-WE2R 180 M4 FAN	FF 300	279	62	328	351	261	241	65	288	121	107	48	48	M16	110	110	14	14
IE2-WE1R 180 L4 FAN	FF 300	279	62	328	351	261	279	65	326	121	114	48	48	M16	110	110	14	14
IE2-WE1R 180 L6, 8 FAN	FF 300	279	62	328	351	261	279	65	326	121	114	48	48	M16	110	110	14	14
IE2-WE1R 200 L2 FAN	FF 350	318	70	372	351	261	305	70	360	133	76	55	48	M20	110	110	16	14
IE2-WE2R 200 LX2 FAN	FF 350	318	70	372	351	261	305	70	360	133	126	55	48	M20	110	110	16	14
IE2-WE1R 200 L4 FAN	FF 350	318	70	372	390	300	305	70	360	133	107	55	55	M20	110	110	16	16
IE2-WE1R 200 LX6 FAN	FF 350	318	70	372	390	300	305	70	360	133	107	55	55	M20	110	110	16	16
IE2-WE1R 200 L6, 8 FAN	FF 350	318	70	372	351	261	305	70	360	133	76	55	48	M20	110	110	16	14
IE2-WE1R 225 M2 FAN	FF 400	356	75	413	390	300	311	75	368	149	125	55	55	M20	110	110	16	16
IE2-WE1R 225 S4 FAN	FF 400	356	75	413	390	300	286	75	343	149	150	60	55	M20	140	110	18	16
IE2-WE1R 225 M4 FAN	FF 400	356	75	413	440	324	311	75	368	149	147	60	55	M20	140	110	18	16
IE2-WE2R 225 M4 FAN	FF 400	356	75	413	390	300	311	75	343	149	175	60	55	M20	140	110	18	16
IE2-WE1R 225 S8 FAN	FF 400	356	75	413	390	300	286	75	368	149	110	60	55	M20	140	110	18	16
IE2-WE1R 225 M6, M8 FAN	FF 400	356	75	413	440	324	311	75	368	149	147	60	55	M20	140	110	18	16
IE2-WE2R 225 M6, 8 FAN	FF 400	356	75	413	390	300	311	75	368	149	125	60	55	M20	140	110	18	16

¹⁾ Centre holes to DIN 332-DS

Three-phase motors with squirrel-cage rotor for use in powered smoke and heat extraction systems to EN 12101-3 Energy-saving motors, High Efficiency IE2

Surface cooling, type of cooling IC 418, degree of protection IP 55
Size 132 to 225

Type of construction IM B35 [IM 2001]

Flange dimensions, see page 8/23

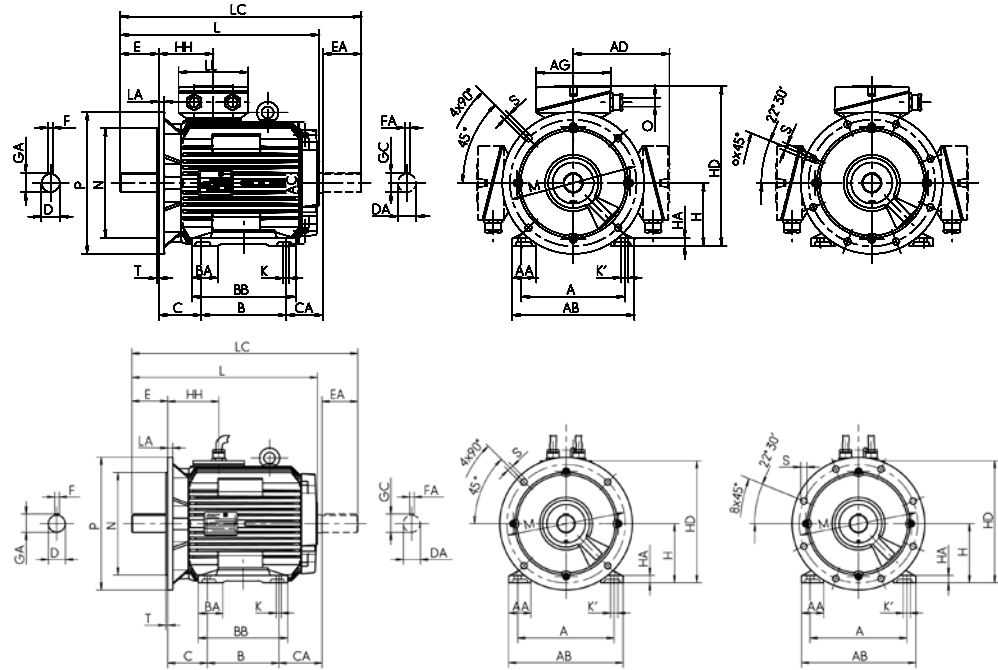

Type designation	GA	GC	H	HA	HD	HD ^{*)}	HD	HH	K	K'	L	LC	TB Type	AG	LL	O	Hole	BI
	t	t1	h	c	p	p	p	A	s	s'	k	k1	Standard	x	z	-	pattern	BI
IE2-WE2R 132 S4 FAN	41	35	132	16	310	256.5	255	108	12	12	474	556	25 A	156	145	M32 x 1.5	4L	35
IE2-WE1R 132 SX2 FAN	41	41	132	15	331	279	276	114	12	12	424	506	25 A	156	145	M32 x 1.5	4L	35
IE2-WE1R 132 M4 FAN	41	41	132	15	331	279	276	114	12	12	472	554	25 A	156	145	M32 x 1.5	4L	35
IE2-WE1R 132 MX6 FAN	41	41	132	15	331	279	276	114	12	12	472	554	25 A	156	145	M32 x 1.5	4L	35
IE2-WE2R 132 M6, 8 FAN	41	35	132	16	310	256.5	255	108	12	12	474	556	25 A	156	145	M32 x 1.5	4L	35
IE2-WE1R 160 M2 FAN	45	45	160	18	409	336	332	138	15	20	512	625	63 A	193	167	M40 x 1.5	4L	35
IE2-WE1R 160 M4 FAN	45	45	160	18	409	336	332	138	15	20	512	625	63 A	193	167	M40 x 1.5	4L	35
IE2-WE2R 160 M4 FAN	45	41	160	18	370	307	304	114	15	15	552	634	25 A	193	167	M32 x 1.5	4L	35
IE2-WE1R 160 M8 FAN	45	41	160	18	363	307	304	114	15	15	502	584	25 A	156	145	M32 x 1.5	4L	35
IE2-WE1R 160 M6, MX8 FAN	45	45	160	18	409	336	332	138	15	20	512	625	63 A	193	167	M40 x 1.5	4L	35
IE2-WE2R 160 M6, MX8 FAN	45	41	160	18	370	307	304	114	15	15	552	634	25 A	193	167	M32 x 1.5	4L	35
IE2-WE1R 160 MX2 FAN	45	45	160	18	409	336	332	138	15	20	550	663	63 A	193	167	M40 x 1.5	4L	35
IE2-WE1R 160 L2 FAN	45	45	160	18	409	336	332	138	15	20	550	663	63 A	193	167	M40 x 1.5	4L	35
IE2-WE2R 160 L4 FAN	45	45	160	18	402	336	332	138	15	20	600	713	63 A	193	167	M40 x 1.5	4L	35
IE2-WE1R 160 L6, 8 FAN	45	45	160	18	409	336	332	138	15	20	550	663	63 A	193	167	M40 x 1.5	4L	35
IE2-WE1R 180 M2 FAN	51.5	51.5	180	20	441	369	371	147	15	20	580	689	63 A	193	167	M40 x 1.5	4L	35
IE2-WE1R 180 M4 FAN	51.5	51.5	180	20	441	369	371	147	15	20	625	734	63 A	193	167	M40 x 1.5	4L	35
IE2-WE2R 180 M4 FAN	51.5	51.5	180	20	441	369	371	147	15	20	580	689	63 A	193	167	M40 x 1.5	4L	35
IE2-WE1R 180 L4 FAN	51.5	51.5	180	20	441	369	371	147	15	20	625	734	63 A	193	167	M40 x 1.5	4L	35
IE2-WE1R 180 L6, 8 FAN	51.5	51.5	180	20	441	369	371	147	15	20	625	734	63 A	193	167	M40 x 1.5	4L	35
IE2-WE1R 200 L2 FAN	59	51.5	200	22	461	389	391	147	19	25	625	734	63 A	193	167	M50 x 1.5	4L	35
IE2-WE2R 200 LX2 FAN	59	51.5	200	22	461	389	391	147	19	25	675	784	63 A	193	167	M50 x 1.5	4L	35
IE2-WE1R 200 L4 FAN	59	59	200	22	500	417	411	168	19	25	658	765	100 A	213	207	M50 x 1.5	4L	35
IE2-WE1R 200 LX6 FAN	59	59	200	22	500	417	411	168	19	25	658	765	100 A	213	207	M50 x 1.5	4L	35
IE2-WE1R 200 L6, 8 FAN	59	51.5	200	22	461	389	391	147	19	25	625	734	63 A	193	167	M50 x 1.5	4L	35
IE2-WE1R 225 M2 FAN	59	59	225	25	527	442	436	168	19	25	698	805	100 A	213	207	M50 x 1.5	8L	40
IE2-WE1R 225 S4 FAN	64	59	225	25	527	442	436	168	19	25	728	835	100 A	213	207	M50 x 1.5	8L	40
IE2-WE1R 225 M4 FAN	64	59	225	25	549	450	460	177	19	25	737	857	100 A	213	207	M50 x 1.5	8L	45
IE2-WE2R 225 M4 FAN	64	59	225	25	527	442	436	168	19	25	778	885	100 A	213	207	M50 x 1.5	8L	40
IE2-WE1R 225 S8 FAN	64	59	225	25	527	442	436	168	19	25	688	795	100 A	213	207	M50 x 1.5	8L	40
IE2-WE1R 225 M6, M8 FAN	64	59	225	25	549	450	460	177	19	25	737	857	100 A	213	207	M50 x 1.5	8L	45
IE2-WE2R 225 M6, 8 FAN	64	59	225	25	527	442	436	168	19	25	728	835	100 A	213	207	M50 x 1.5	8L	40

**) Terminal box left/right

**Three-phase motors with squirrel-cage rotor for use in powered smoke and heat extraction systems to EN 12101-3
Energy-saving motors, High Efficiency IE2**

Surface cooling, type of cooling IC 418, degree of protection IP 55
Size 250 to 280

Type of construction IM B3 [IM 1001]

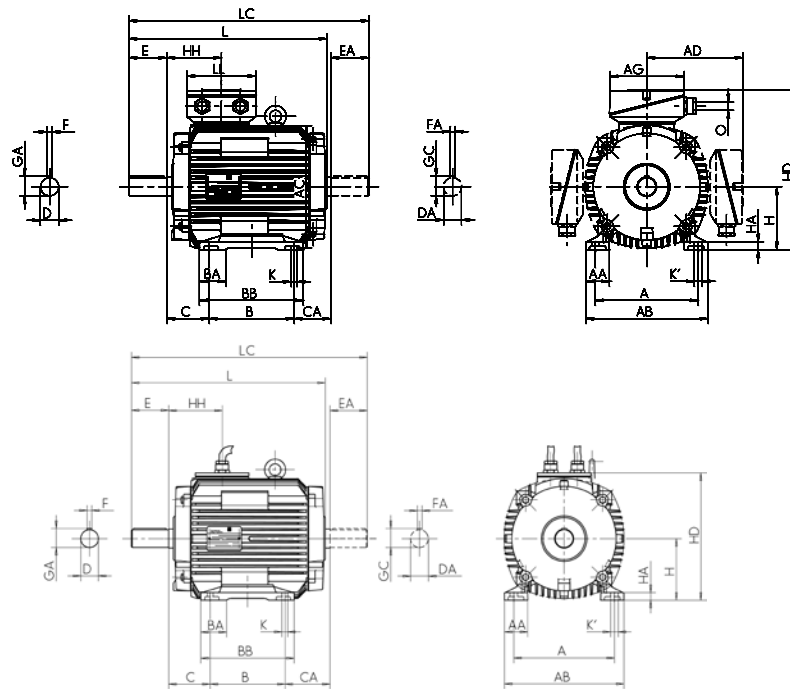

Type designation	Flange size	A	AA	AB	AC	AD	B	BA	BB	C	CA	D	DA	DB ¹⁾	E	EA	F	FA
		b	n	f	g	g1	a	m	e	w1	w2	d	d1		l	l1	u	u1
IE2-WE1R 250 M2 FAN	FF 500	406	84	471	440	358	349	84	412	168	90	60	55	M20	140	110	18	16
IE2-WE1R 250 M4 FAN	FF 500	406	84	469	490	386	349	84	412	168	154	65	55	M20	140	110	18	16
IE2-WE1R 250 M6, 8 FAN	FF 500	406	84	469	490	386	349	84	412	168	154	65	55	M20	140	110	18	16
IE2-WE2R 250 M4, 6 FAN	FF 500	406	84	469	440	386	349	84	412	168	140	65	55	M20	140	110	18	16
IE2-WE1R 280 S2 FAN	FF 500	457	94	522	490	386	368	96	431	190	113	65	65	M20	140	140	18	18
IE2-WE1R 280 M2 FAN	FF 500	457	94	522	490	386	419	96	482	190	109	65	65	M20	140	140	18	18
IE2-WE1R 280 S4 FAN	FF 500	457	94	522	490	386	368	96	431	190	113	75	65	M20	140	140	20	18
IE2-WE1R 280 M4 FAN	FF 500	457	94	522	490	386	419	96	482	190	109	75	65	M20	140	140	20	18
IE2-WE1R 280 S6 FAN	FF 500	457	94	522	490	386	368	96	431	190	160	75	65	M20	140	140	20	18
IE2-WE1R 280 S8 FAN	FF 500	457	94	522	490	386	368	96	431	190	160	75	65	M20	140	140	20	18
IE2-WE1R 280 M6 FAN	FF 500	457	88	522	550	416	419	94	482	190	192	75	65	M20	140	140	20	18
IE2-WE1R 280 M8 FAN	FF 500	457	94	522	490	386	419	96	482	190	109	75	65	M20	140	140	20	18

¹⁾ Centre holes to DIN 332-DS

Three-phase motors with squirrel-cage rotor for use in powered smoke and heat extraction systems to EN 12101-3
Energy-saving motors, High Efficiency IE2

Surface cooling, type of cooling IC 418, degree of protection IP 55
 Size 250 to 280

Type of construction IM B35 [IM 2001]

Flange dimensions, see page 8/23

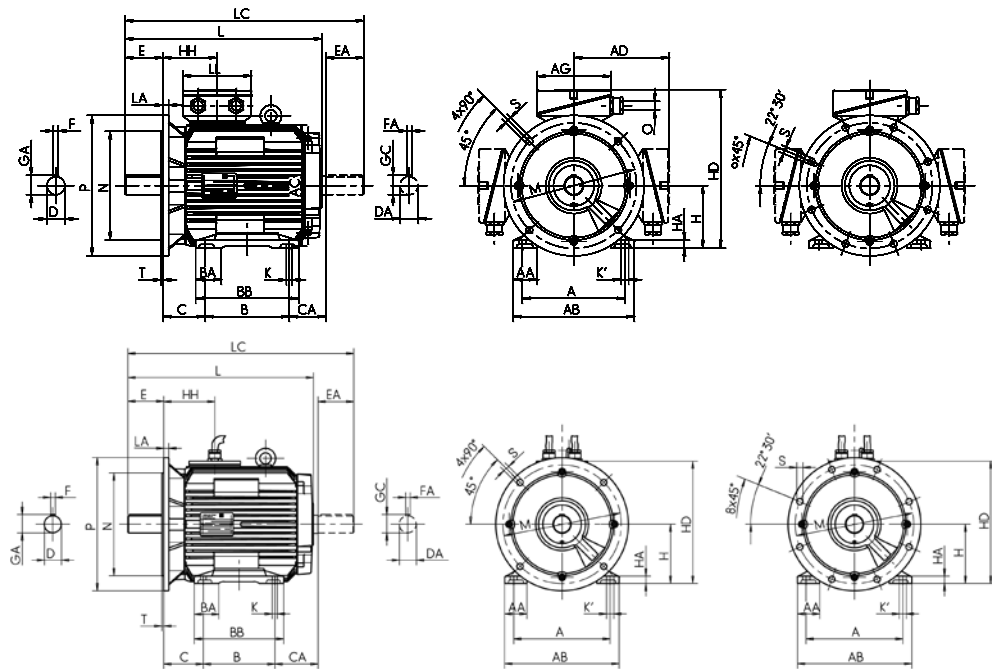

Type designation	GA	GC	H	HA	HD	HD ^{**})	HD	HH	K	K'	L	LC	TB Type	AG	LL	O	Hole	BI
	t	t1	h	c	p	p	p	A	s	s'	k	k1	Standard	x	z	-	pattern	Bl
IE2-WE1R 250 M2 FAN	64	59	250	28	608	484	485	177	24	30	737	857	200 A	282	242	M63 x 1.5	8L	45
IE2-WE1R 250 M4 FAN	69	59	250	28	636	493	535	206	24	30	801	921	200 A	282	242	M63 x 1.5	8L	50
IE2-WE1R 250 M6, 8 FAN	69	59	250	28	636	493	535	206	24	30	801	921	200 A	282	242	M63 x 1.5	8L	50
IE2-WE2R 250 M4, 6 FAN	69	59	250	28	636	484	485	177	24	30	787	907	200 A	282	242	M63 x 1.5	8L	50
IE2-WE1R 280 S2 FAN	69	69	280	32	666	523	565	206	24	30	801	951	200 A	282	242	M63 x 1.5	8L	50
IE2-WE1R 280 M2 FAN	69	69	280	32	666	523	565	206	24	30	848	998	200 A	282	242	M63 x 1.5	8L	50
IE2-WE1R 280 S4 FAN	79.5	69	280	32	666	523	565	206	24	30	801	951	200 A	282	242	M63 x 1.5	8L	50
IE2-WE1R 280 M4 FAN	79.5	69	280	32	666	523	565	206	24	30	848	998	200 A	282	242	M63 x 1.5	8L	50
IE2-WE1R 280 S6 FAN	79.5	69	280	32	666	523	565	206	24	30	848	998	200 A	282	242	M63 x 1.5	8L	50
IE2-WE1R 280 S8 FAN	79.5	69	280	32	666	523	565	206	24	30	848	998	200 A	282	242	M63 x 1.5	8L	50
IE2-WE1R 280 M6 FAN	79.5	69	280	40	696	555	595	211	24	30	934	1081	200 A	282	242	M63 x 1.5	8L	55
IE2-WE1R 280 M8 FAN	79.5	69	280	32	696	523	565	206	24	30	848	998	200 A	282	242	M63 x 1.5	8L	55

***) Terminal box left/right

Three-phase motors with squirrel-cage rotor for use in powered smoke and heat extraction systems to EN 12101-3
Energy-saving motors, High Efficiency IE2

Surface cooling, type of cooling IC 418, degree of protection IP 55
 Size 315

Type of construction IM B3 [IM 1001]

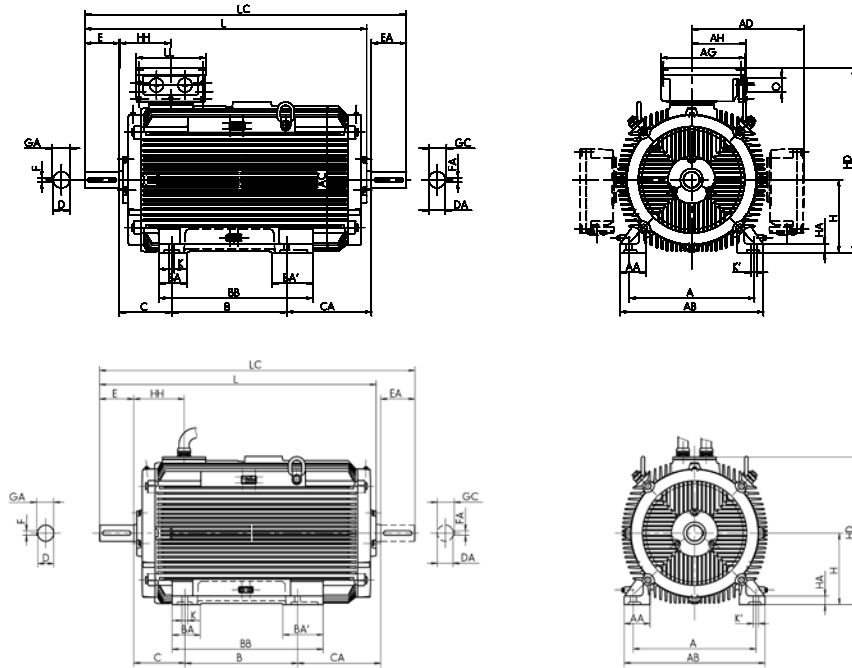

Type designation	Flange size	A	AA	AB	AC	AD	B	BA	BA'	BB	C	CA	D	DA	DB ¹⁾	E	EA	F	FA
		b	n	f	g	g1	a	m	m1	e	w1	w2	d	d1		l	l1	u	u1
IE2-WE1R 315 S2 FAN	FF 600	508	126	590	550	416	406	120	-	503	216	124	65	65	M20	140	140	18	18
IE2-WE1R 315 M2 FAN	FF 600	508	126	590	550	416	457	120	150	554	216	128	65	65	M20	140	140	18	18
IE2-WE1R 315 MX2 FAN	FF 600	508	126	590	550	416	457	120	150	554	216	208	65	65	M20	140	140	18	18
IE2-WE1R 315 MY2 FAN	FF 600	508	110	590	610	494	457	120	-	573	216	304	65	65	M20	140	140	18	18
IE2-WE1R 315 L2 FAN	FF 600	508	110	590	610	494	508	120	-	624	216	373	65	65	M20	140	140	18	18
IE2-WE1R 315 LX2 FAN	FF 600	508	110	590	610	494	508	120	-	624	216	493	65	65	M20	140	140	18	18
IE2-WE1R 315 S4 FAN	FF 600	508	126	590	550	416	406	120	-	503	216	124	80	70	M20	170	140	22	20
IE2-WE1R 315 M4 FAN	FF 600	508	126	590	550	416	457	120	150	554	216	128	80	70	M20	170	140	22	20
IE2-WE1R 315 MX4 FAN	FF 600	508	126	590	550	416	457	120	150	554	216	208	80	70	M20	170	140	22	20
IE2-WE1R 315 MY4 FAN	FF 600	508	110	590	610	494	457	120	-	573	216	304	80	70	M20	170	140	22	20
IE2-WE1R 315 L4 FAN	FF 600	508	110	590	610	494	508	120	-	624	216	373	80	70	M20	170	140	22	20
IE2-WE1R 315 LX4 FAN	FF 600	508	110	590	610	494	508	120	-	624	216	493	80	70	M20	170	140	22	20
IE2-WE1R 315 S6 FAN	FF 600	508	126	590	550	416	406	120	150	554	216	179	80	70	M20	170	140	22	20
IE2-WE1R 315 M6 FAN	FF 600	508	126	590	550	416	457	120	150	554	216	128	80	70	M20	170	140	22	20
IE2-WE1R 315 MX6 FAN	FF 600	508	110	590	610	494	457	120	-	573	216	234	80	70	M20	170	140	22	20
IE2-WE1R 315 MY6 FAN	FF 600	508	110	590	610	494	457	120	-	573	216	234	80	70	M20	170	140	22	20
IE2-WE1R 315 L6 FAN	FF 600	508	110	590	610	494	508	120	-	624	216	373	80	70	M20	170	140	22	20
IE2-WE1R 315 LX6 FAN	FF 600	508	110	590	610	494	508	120	-	624	216	373	80	70	M20	170	140	22	20
IE2-WE1R 315 S8 FAN	FF 600	508	126	590	550	416	406	120	-	503	216	124	80	70	M20	170	140	22	20
IE2-WE1R 315 M8 FAN	FF 600	508	126	590	550	416	457	120	150	554	216	128	80	70	M20	170	140	22	20
IE2-WE1R 315 MX8 FAN	FF 600	508	126	590	550	416	457	120	150	554	216	128	80	70	M20	170	140	22	20
IE2-WE1R 315 MY8 FAN	FF 600	508	110	590	610	494	457	120	-	573	216	304	80	70	M20	170	140	22	20
IE2-WE1R 315 L8 FAN	FF 600	508	110	590	610	494	508	120	-	624	216	373	80	70	M20	170	140	22	20
IE2-WE1R 315 LX8 FAN	FF 600	508	110	590	610	494	508	120	-	624	216	373	80	70	M20	170	140	22	20

¹⁾ Centre holes to DIN 332-DS

Three-phase motors with squirrel-cage rotor for use in powered smoke and heat extraction systems to EN 12101-3 Energy-saving motors, High Efficiency IE2

Surface cooling, type of cooling IC 418, degree of protection IP 55
Size 315

Type of construction IM B35 [IM 2001]

Flange dimensions, see page 8/23

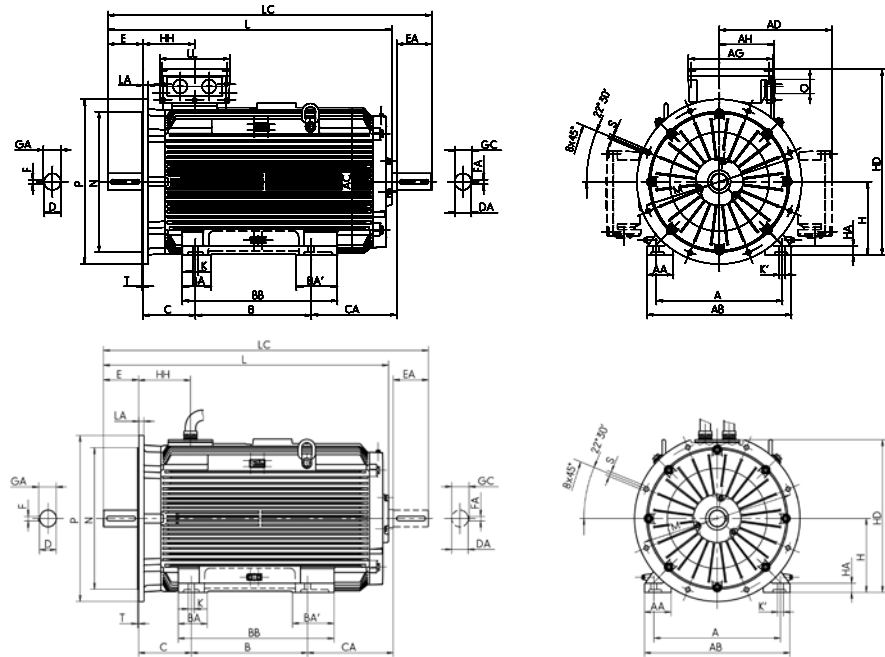

Type designation	GA	GC	H	HA	HD	HD ^{**}	HD	HH	K	K'	L	LC	TB Type	AG	LL	AH	O	BI
	t	t1	h	c	p	p	p	A	s	s'	k	k1	Standard	x	z	-	r	BI
IE2-WE1R 315 S2 FAN	69	69	315	44	731	595	630	211	28	35	879	1026	200 A	282	242	-	M63 x 1.5	55
IE2-WE1R 315 M2 FAN	69	69	315	44	731	595	630	211	28	35	934	1081	200 A	282	242	-	M63 x 1.5	55
IE2-WE1R 315 MX2 FAN	69	69	315	44	731	595	630	211	28	35	1014	1161	200 A	282	242	-	M63 x 1.5	55
IE2-WE1R 315 MY2 FAN	69	69	315	44	809	628	663	230	28	35	1113	1257	400 B	415	340	265	M63 x 1.5	55
IE2-WE1R 315 L2 FAN	69	69	315	44	809	628	663	230	28	35	1233	1377	400 B	415	340	265	M63 x 1.5	55
IE2-WE1R 315 LX2 FAN	69	69	315	44	809	628	663	230	28	35	1353	1497	400 B	415	340	265	M63 x 1.5	55
IE2-WE1R 315 S4 FAN	85	74.5	315	44	731	595	630	211	28	35	909	1056	200 A	282	242	-	M63 x 1.5	55
IE2-WE1R 315 M4 FAN	85	74.5	315	44	731	595	630	211	28	35	964	1111	200 A	282	242	-	M63 x 1.5	55
IE2-WE1R 315 MX4 FAN	85	74.5	315	44	731	595	630	211	28	35	1044	1191	200 A	282	242	-	M63 x 1.5	55
IE2-WE1R 315 MY4 FAN	85	74.5	315	44	809	628	663	230	28	35	1143	1287	400 B	415	340	265	M63 x 1.5	55
IE2-WE1R 315 L4 FAN	85	74.5	315	44	809	628	663	230	28	35	1263	1407	400 B	415	340	265	M63 x 1.5	55
IE2-WE1R 315 LX4 FAN	85	74.5	315	44	809	628	663	230	28	35	1383	1527	400 B	415	340	265	M63 x 1.5	55
IE2-WE1R 315 S6 FAN	85	74.5	315	44	731	595	630	211	28	35	964	1111	200 A	282	242	-	M63 x 1.5	55
IE2-WE1R 315 M6 FAN	85	74.5	315	44	731	595	630	211	28	35	964	1111	200 A	282	242	265	M63 x 1.5	55
IE2-WE1R 315 MX6 FAN	85	74.5	315	44	809	628	663	230	28	35	1073	1217	400 B	415	340	265	M63 x 1.5	55
IE2-WE1R 315 MY6 FAN	85	74.5	315	44	809	628	663	230	28	35	1073	1217	400 B	415	340	265	M63 x 1.5	55
IE2-WE1R 315 L6 FAN	85	74.5	315	44	809	628	663	230	28	35	1263	1407	400 B	415	340	265	M63 x 1.5	55
IE2-WE1R 315 LX6 FAN	85	74.5	315	44	809	628	663	230	28	35	1263	1407	400 B	415	340	265	M63 x 1.5	55
IE2-WE1R 315 S8 FAN	85	74.5	315	44	731	595	630	211	28	35	909	1056	200 A	282	242	-	M63 x 1.5	55
IE2-WE1R 315 M8 FAN	85	74.5	315	44	731	595	630	211	28	35	964	1111	200 A	282	242	-	M63 x 1.5	55
IE2-WE1R 315 MX8 FAN	85	74.5	315	44	731	595	630	211	28	35	964	1111	200 A	282	242	-	M63 x 1.5	55
IE2-WE1R 315 MY8 FAN	85	74.5	315	44	809	628	663	230	28	35	1143	1287	400 B	415	340	265	M63 x 1.5	55
IE2-WE1R 315 L8 FAN	85	74.5	315	44	809	628	663	230	28	35	1263	1407	400 B	415	340	265	M63 x 1.5	55
IE2-WE1R 315 LX8 FAN	85	74.5	315	44	809	628	663	230	28	35	1263	1407	400 B	415	340	265	M63 x 1.5	55

***) Terminal box left/right

Three-phase motors with squirrel-cage rotor for use in powered smoke and heat extraction systems to EN 12101-3 Energy-saving motors, High Efficiency IE2

Surface cooling, type of cooling IC 418, degree of protection IP 55
Size 355

Type of construction IM B3 [IM 1001]

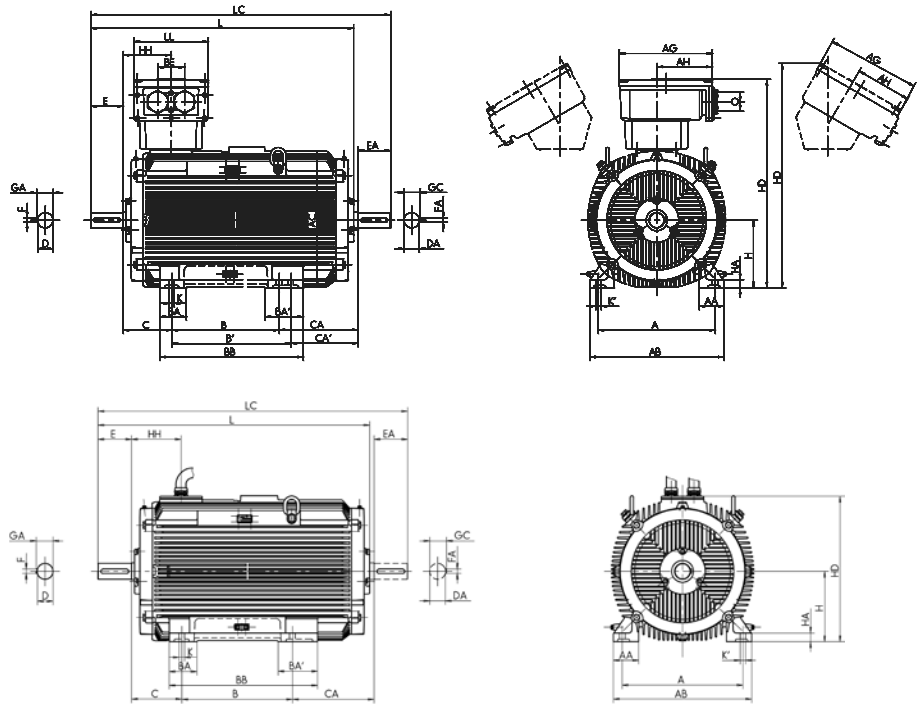

Type designation	Flange size	A	AA	AB	AC	B	BA	BA'	BB	C	CA	D	DA	DB'	E	EA	F	FA
		b	n	f	g	a	m	m1	e	w1	w2	d	d1		l	l1	u	u1
IE2-WE2R 355 M2 FAN	FF 740	610	130	700	715	560	140	200	750	254	404	80	80	M20	170	170	22	22
IE2-WE2R 355 M4 FAN	FF 740	610	130	700	715	560	140	200	750	254	404	100	80	M24	210	170	28	22
IE2-WE2R 355 M6, 8 FAN	FF 740	610	130	700	715	560	140	200	750	254	404	100	80	M24	210	170	28	22
IE2-WE2R 355 MX6, 8 FAN	FF 740	610	130	700	715	560	140	200	750	254	524	100	80	M24	210	170	28	22
IE2-WE2R 355 MX2 FAN	FF 740	610	130	700	715	560	140	200	750	254	524	80	80	M20	170	170	22	22
IE2-WE2R 355 LY2, L2 FAN	FF 740	610	130	700	715	630	140	200	750	254	454	80	80	M20	170	170	22	22
IE2-WE2R 355 MX4 FAN	FF 740	610	130	700	715	560	140	200	750	254	524	100	80	M24	210	170	28	22
IE2-WE2R 355 LY4, L4 FAN	FF 740	610	130	700	715	630	140	200	750	254	454	100	80	M24	210	170	28	22
IE2-WE2R 355 LY6, 8 FAN	FF 740	610	130	700	715	630	140	200	750	254	454	100	80	M24	210	170	28	22

¹ Centre holes to DIN 332-DS

Three-phase motors with squirrel-cage rotor for use in powered smoke and heat extraction systems to EN 12101-3
Energy-saving motors, High Efficiency IE2

Surface cooling, type of cooling IC 418, degree of protection IP 55
 Size 355

Type of construction IM B35 [IM 1001]

Flange dimensions, see page 8/23

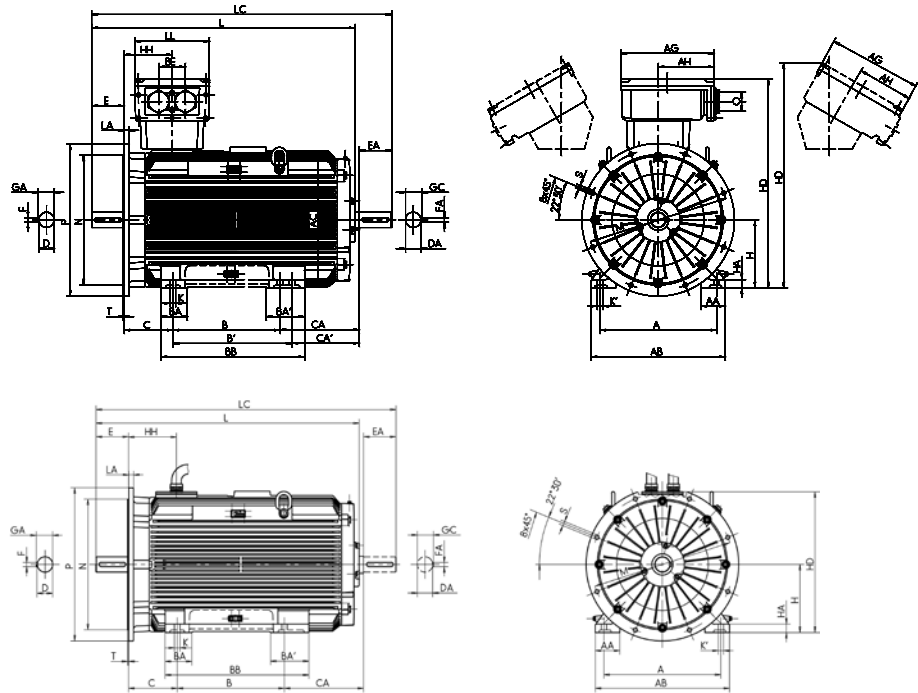

Type designation	GA	GC	H	HA	HD	HD ^{*)}	HD	HH	K	K'	L	LC	TB Type	AG	LL	AH	BE	O	BI
	t	t1	h	c	p	p	p	A	s	s'	k	k1		x	z	-	-	r	BI
IE2-WE2R 355 M2 FAN	85	85	355	44	1091	1172	839	250	28	35	1365	1558	630 A	496	390	301	140	M72x2	60
IE2-WE2R 355 M4 FAN	106	85	355	44	1091	1172	839	250	28	35	1405	1598	630 A	496	390	301	140	M72x2	60
IE2-WE2R 355 M6, 8 FAN	106	85	355	44	1091	1172	839	250	28	35	1405	1598	630 A	496	390	301	140	M72x2	60
IE2-WE2R 355 MX6, 8 FAN	106	85	355	44	1091	1172	839	250	28	35	1525	1718	630 A	496	390	301	140	M72x2	60
IE2-WE2R 355 MX2 FAN	85	85	355	44	1083	1174	839	327	28	35	1485	1678	1000 A	615	474	385	200	M72x2	60
IE2-WE2R 355 LY2, L2 FAN	85	85	355	44	1083	1174	839	327	28	35	1485	1678	1000 A	615	474	385	200	M72x2	60
IE2-WE2R 355 MX4 FAN	106	85	355	44	1083	1174	839	327	28	35	1525	1718	1000 A	615	474	385	200	M72x2	60
IE2-WE2R 355 LY4, L4 FAN	106	85	355	44	1083	1174	839	327	28	35	1525	1718	1000 A	615	474	385	200	M72x2	60
IE2-WE2R 355 LY6, 8 FAN	106	85	355	44	1083	1174	839	327	28	35	1525	1718	1000 A	615	474	385	200	M72x2	60

^{*)} Terminal box inclined left/right

**Three-phase motors with squirrel-cage rotor for use in powered smoke and heat extraction systems to EN 12101-3
Energy-saving motors, High Efficiency IE2**

Surface cooling, type of cooling IC 418, degree of protection IP 55
Size 132 to 160

Type of construction IM B14 [IM 3601]

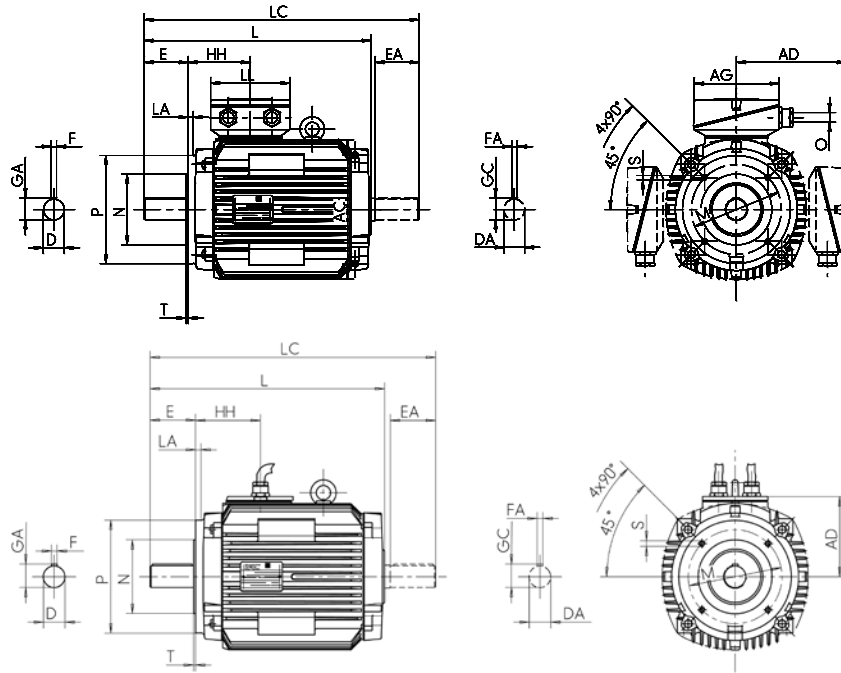

Type designation	Flange size		A	AA	AB	AC	AD	B	BA	BB	C	CA	D	DA	DB ¹⁾	E	EA	F	FA
	small	large	n	f	g	g1	a	m	m1	e	w1	w2	d	d1		l	l1	u	u1
IE2-WE2R 132 S4 FAN	FT 130	FT 165	216	50	256	217	178	140	53	180	89	167	38	32	M12	80	80	10	10
IE2-WE1R 132 SX2 FAN	FT 165	FT 215	216	50	256	258	199	140	53	180	89	117	38	38	M12	80	80	10	10
IE2-WE1R 132 M4 FAN	FT 165	FT 215	216	50	256	258	199	178	53	218	89	127	38	38	M12	80	80	10	10
IE2-WE1R 132 MX6 FAN	FT 165	FT 215	216	50	256	258	199	178	53	218	89	127	38	38	M12	80	80	10	10
IE2-WE2R 132 M6, 8 FAN	FT 130	FT 165	216	50	256	217	178	178	53	218	89	129	38	32	M12	80	80	10	10
IE2-WE1R 160 M2 FAN	FT 215	FT 268	254	55	296	313	242	210	60	257	108	87	42	42	M16	110	110	12	12
IE2-WE1R 160 M4 FAN	FT 215	FT 268	254	55	296	313	242	210	60	257	108	87	42	42	M16	110	110	12	12
IE2-WE1R 160 M8 FAN	FT 165	FT 215	254	55	296	258	214	210	60	257	108	76	42	38	M16	110	80	12	10
IE2-WE1R 160 M6, MX8 FAN	FT 215	FT 265	254	55	296	313	242	210	60	257	108	87	42	42	M16	110	110	12	12
IE2-WE2R 160 M4, 6, MX8 FAN	FT 165	FT 215	254	55	296	258	214	210	60	257	108	126	42	38	M16	110	80	12	10
IE2-WE1R 160 MX2 FAN	FT 215	FT 265	254	55	296	313	242	210	56	257	108	125	42	42	M16	110	110	12	12
IE2-WE1R 160 L2 FAN	FT 215	FT 265	254	55	296	313	242	254	60	301	108	81	42	42	M16	110	110	12	12
IE2-WE2R 160 L4 FAN	FT 215	FT 265	254	55	296	313	242	254	60	301	108	131	42	42	M16	110	110	12	12
IE2-WE1R 160 L6, 8 FAN	FT 215	FT 265	254	55	296	313	242	254	60	301	108	81	42	42	M16	110	110	12	12

¹⁾ Centre holes to DIN 332-DS

Three-phase motors with squirrel-cage rotor for use in powered smoke and heat extraction systems to EN 12101-3 Energy-saving motors, High Efficiency IE2

Surface cooling, type of cooling IC 418, degree of protection IP 55
Size 132 to 160

Type of construction IM B34 [IM 2101]

Flange dimensions, see page 8/23

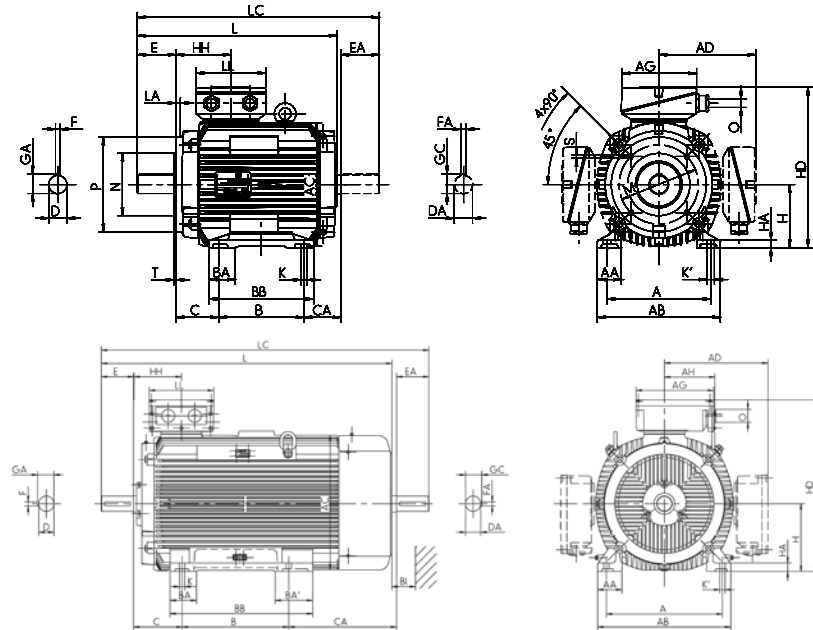

Type designation	GA	GC	H	HA	HD	HD**)	HD	HH	K	K'	L	LC	TB Type	AG	LL	O	Hole	BI
	t	t1	h	c	p	p	p	A	s	s'	k	k1	Standard	x	z	-	pattern	Bl
IE2-WE2R 132 S4 FAN	41	35	132	16	310	257	255	108	12	12	474	556	25 A	156	145	M32 x 1.5	4L	35
IE2-WE1R 132 SX2 FAN	41	41	132	15	331	279	276	114	12	12	424	506	25 A	156	145	M32 x 1.5	4L	35
IE2-WE1R 132 M4 FAN	41	41	132	16	331	279	276	114	12	12	472	554	25 A	156	145	M32 x 1.5	4L	35
IE2-WE1R 132 MX6 FAN	41	41	132	15	331	279	276	114	12	12	472	554	25 A	156	145	M32 x 1.5	4L	35
IE2-WE2R 132 M6, 8 FAN	41	35	132	16	310	257	255	108	12	12	474	556	25 A	156	145	M32 x 1.5	4L	35
IE2-WE1R 160 M2 FAN	45	45	160	18	402	307	332	138	15	20	512	625	63 A	193	167	M40 x 1.5	4L	35
IE2-WE1R 160 M4 FAN	45	45	160	18	402	336	332	138	15	20	512	625	63 A	193	167	M40 x 1.5	4L	35
IE2-WE1R 160 M8 FAN	45	41	160	18	374	307	304	114	15	15	502	584	25 A	193	167	M32 x 1.5	4L	35
IE2-WE1R 160 M6, MX8 FAN	45	45	160	18	402	336	332	138	15	20	512	625	63 A	193	167	M40 x 1.5	4L	35
IE2-WE2R 160 M4, 6, MX8 FAN	45	41	160	18	370	307	304	114	15	15	552	634	25 A	193	167	M32 x 1.5	4L	35
IE2-WE1R 160 MX2 FAN	45	45	160	18	402	336	332	138	15	20	550	663	63 A	193	167	M40 x 1.5	4L	35
IE2-WE1R 160 L2 FAN	45	45	160	18	402	336	332	138	15	20	550	663	63 A	193	167	M40 x 1.5	4L	35
IE2-WE2R 160 L4 FAN	45	45	160	18	402	336	332	138	15	20	600	713	63 A	193	167	M40 x 1.5	4L	35
IE2-WE1R 160 L6, 8 FAN	45	45	160	18	402	336	332	138	15	20	550	663	63 A	193	167	M40 x 1.5	4L	35

**) Terminal box left/right

Three-phase motors with squirrel-cage rotor for use in powered smoke and heat extraction systems to EN 12101-3
Energy-saving motors, High Efficiency IE2

Surface cooling, type of cooling IC 418, degree of protection IP 55
 Size 132 to 280

Type of construction IM B5 [IM 3001]
Type of construction IM V1 [IM 3011]

Flange dimensions, see page 8/23

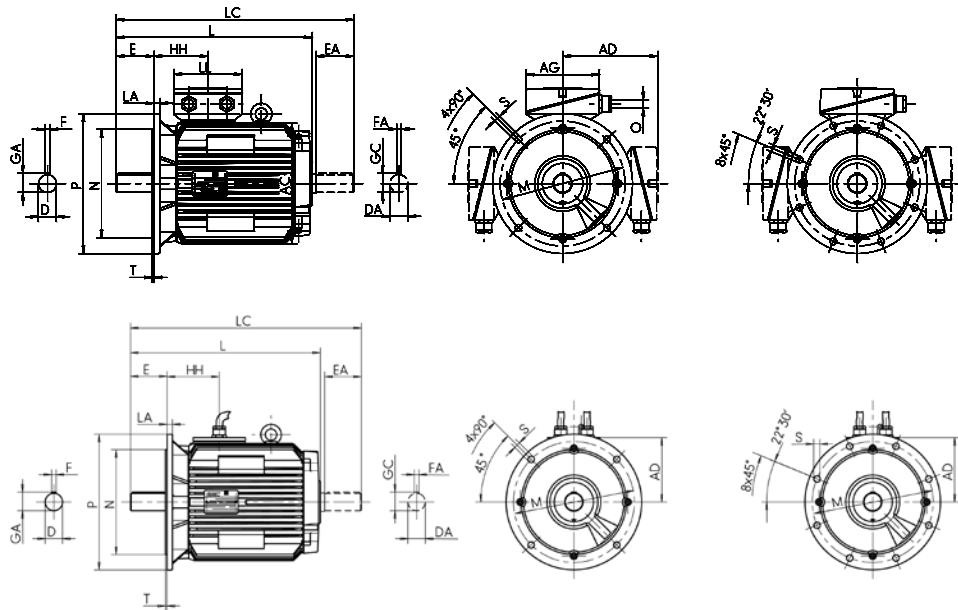

Type designation	Flange size	AC	AD	AD	D	DA	DB ¹⁾	E	EA	F	FA	GA	GC	H	HH	L	LC	TB Type	AG	LL	O	Hole	BI
		g	g1	g1	d	d1		l	l1	u	u1	t	t1	h	A	k	k1	Standard	x	z	-	pattern	BI
IE2-WE1R 132 SX2 FAN	FF 265	258	210	144	38	32	M12	80	80	10	10	41	41	132	114	424	506	25 A	156	145	M32 x 1.5	4L	35
IE2-WE1R 132 M4 FAN	FF 265	258	210	144	38	38	M12	80	80	10	10	41	41	132	114	472	554	25 A	156	145	M32 x 1.5	4L	35
IE2-WE1R 132 MX6 FAN	FF 265	258	210	144	38	38	M12	80	80	10	10	41	41	132	114	472	554	25 A	156	145	M32 x 1.5	4L	35
IE2-WE1R 160 M2 FAN	FF 300	313	242	172	42	38	M16	110	110	12	12	45	45	160	138	512	625	63 A	193	167	M40 x 1.5	4L	35
IE2-WE1R 160 M4 FAN	FF 300	313	242	172	42	38	M16	110	110	12	12	45	45	160	138	512	625	63 A	193	167	M40 x 1.5	4L	35
IE2-WE2R 160 M4 FAN	FF 300	258	214	144	42	38	M16	110	80	12	10	45	41	160	114	552	634	25 A	193	167	M32 x 1.5	4L	35
IE2-WE1R 160 M8 FAN	FF 300	258	214	144	42	38	M16	110	80	12	10	45	41	160	114	502	584	25 A	193	167	M32 x 1.5	4L	35
IE2-WE1R 160 M6, MX8 FAN	FF 300	313	242	172	42	38	M16	110	110	12	12	45	45	160	138	512	625	63 A	193	167	M40 x 1.5	4L	35
IE2-WE2R 160 M6, MX8 FAN	FF 300	258	214	144	42	38	M16	110	80	12	10	45	41	160	114	552	634	25 A	193	167	M32 x 1.5	4L	35
IE2-WE1R 160 MX2 FAN	FF 300	313	242	172	42	42	M16	110	110	12	12	45	45	160	138	550	663	63 A	193	167	M40 x 1.5	4L	35
IE2-WE1R 160 L2 FAN	FF 300	313	242	172	42	42	M16	110	110	12	12	45	45	160	138	550	663	63 A	193	167	M40 x 1.5	4L	35
IE2-WE2R 160 L4 FAN	FF 300	313	242	172	42	42	M16	110	110	12	12	45	45	160	138	600	713	63 A	193	167	M40 x 1.5	4L	35
IE2-WE1R 160 L6, 8 FAN	FF 300	313	242	172	42	42	M16	110	110	12	12	45	45	160	138	550	663	63 A	193	167	M40 x 1.5	4L	35
IE2-WE1R 180 M2 FAN	FF 300	351	261	191	48	48	M16	110	110	14	14	51.5	51.5	180	147	580	689	63 A	193	167	M40 x 1.5	4L	35
IE2-WE1R 180 M4 FAN	FF 300	351	261	191	48	48	M16	110	110	14	14	51.5	51.5	180	147	625	734	63 A	193	167	M40 x 1.5	4L	35
IE2-WE2R 180 M4 FAN	FF 300	351	261	191	48	48	M16	110	110	14	14	51.5	51.5	180	147	580	689	63 A	193	167	M40 x 1.5	4L	35
IE2-WE1R 180 L4 FAN	FF 300	351	261	191	48	48	M16	110	110	14	14	51.5	51.5	180	147	625	734	63 A	193	167	M40 x 1.5	4L	35
IE2-WE1R 180 L6, 8 FAN	FF 300	351	261	191	48	48	M16	110	110	14	14	51.5	51.5	180	147	625	734	63 A	193	167	M40 x 1.5	4L	35
IE2-WE1R 200 L2 FAN	FF 350	351	261	191	55	48	M20	110	110	16	14	59	51.5	200	147	625	734	63 A	193	167	M40 x 1.5	4L	35
IE2-WE2R 200 LX2 FAN	FF 350	351	261	191	55	48	M20	110	110	16	14	59	51.5	200	147	675	784	63 A	193	167	M50 x 1.5	4L	35
IE2-WE1R 200 L4 FAN	FF 350	390	300	211	55	55	M20	110	110	16	16	59	59	200	168	658	765	100 A	213	207	M50 x 1.5	4L	35
IE2-WE1R 200 LX6 FAN	FF 350	390	300	211	55	55	M20	110	110	16	16	59	59	200	168	658	765	100 A	213	207	M50 x 1.5	4L	35
IE2-WE1R 200 L6, 8 FAN	FF 350	351	261	191	55	48	M20	110	110	16	14	59	51.5	200	147	625	734	63 A	193	167	M50 x 1.5	4L	35
IE2-WE1R 225 M2 FAN	FF 400	390	300	211	55	55	M20	110	110	16	16	59	59	225	168	698	805	100 A	213	207	M50 x 1.5	8L	40
IE2-WE1R 225 S4 FAN	FF 400	390	300	211	60	55	M20	140	110	18	16	64	59	225	168	728	835	100 A	213	207	M50 x 1.5	8L	40
IE2-WE1R 225 M4 FAN	FF 400	440	324	235	60	55	M20	140	110	18	16	64	59	225	177	737	857	100 A	213	207	M50 x 1.5	8L	45
IE2-WE2R 225 M4 FAN	FF 400	390	300	211	60	55	M20	140	110	18	16	64	59	225	168	778	885	100 A	213	207	M50 x 1.5	8L	40
IE2-WE1R 225 S8 FAN	FF 400	390	300	211	60	55	M20	140	110	18	16	64	59	225	168	688	795	100 A	213	207	M50 x 1.5	8L	40
IE2-WE1R 225 M6, M8 FAN	FF 400	440	324	235	60	55	M20	140	110	18	16	64	59	225	177	737	857	100 A	213	207	M50 x 1.5	8L	45
IE2-WE2R 225 M6, 8 FAN	FF 400	390	300	211	60	55	M20	140	110	18	16	64	59	225	168	728	835	100 A	213	207	M50 x 1.5	8L	40

Type designation	Flange size	AC g	AD with TB g1	AD Cable g1	D d	DA d1	DB ¹⁾	E l	EA l1	F u	FA u1	GA t	GC t1	H h	HH A	L k	LC k1	TB Type Standard	AG x	LL z	O -	Hole pattern	BI BI
IE2-WE1R 250 M2 FAN	FF 500	440	358	235	60	55	M20	140	110	18	16	64	59	250	177	737	857	100 A	282	242	M50 x 1.5	8L	45
IE2-WE1R 250 M4 FAN	FF 500	490	386	285	65	55	M20	140	110	18	16	69	59	250	206	801	921	200 A	282	242	M63 x 1.5	8L	50
IE2-WE2R 250 M6, 8 FAN	FF 500	440	386	235	65	55	M20	140	110	18	16	69	59	250	177	787	907	100 A	282	242	M50 x 1.5	8L	50
IE2-WE1R 250 M6, 8 FAN	FF 500	490	386	285	65	55	M20	140	110	18	16	69	59	250	206	801	921	200 A	282	242	M63 x 1.5	8L	50
IE2-WE1R 280 S2 FAN	FF 500	490	386	285	65	65	M20	140	140	18	18	69	69	280	206	801	951	200 A	282	242	M63 x 1.5	8L	50
IE2-WE1R 280 M2 FAN	FF 500	490	386	285	65	65	M20	140	140	18	18	69	69	280	206	848	998	200 A	282	242	M63 x 1.5	8L	50
IE2-WE1R 280 S4 FAN	FF 500	490	386	285	75	65	M20	140	140	20	18	79.5	69	280	206	801	951	200 A	282	242	M63 x 1.5	8L	50
IE2-WE1R 280 M4 FAN	FF 500	490	386	285	75	65	M20	140	140	20	18	79.5	69	280	206	848	998	200 A	282	242	M63 x 1.5	8L	50
IE2-WE1R 280 S6 FAN	FF 500	490	386	285	75	65	M20	140	140	20	18	79.5	69	280	206	848	998	200 A	282	242	M63 x 1.5	8L	50
IE2-WE1R 280 S8 FAN	FF 500	490	386	285	75	65	M20	140	140	20	18	79.5	69	280	206	848	998	200 A	282	242	M63 x 1.5	8L	50
IE2-WE1R 280 M6 FAN	FF 500	550	416	315	75	65	M20	140	140	20	18	79.5	69	280	211	934	1081	200 A	282	242	M63 x 1.5	8L	55
IE2-WE1R 280 M8 FAN	FF 500	550	386	285	75	65	M20	140	140	20	18	79.5	69	280	206	848	998	200 A	282	242	M63 x 1.5	8L	55

¹⁾ Centre holes to DIN 332-DS

^{**)} Terminal box left/right

Three-phase motors with squirrel-cage rotor for use in powered smoke and heat extraction systems to EN 12101-3
Energy-saving motors, High Efficiency IE2

Surface cooling, type of cooling IC 418, degree of protection IP 55
 Size 315

Type of construction IM B5 [IM 3001]
Type of construction IM V1 [IM 3011]

Flange dimensions, see page 8/23

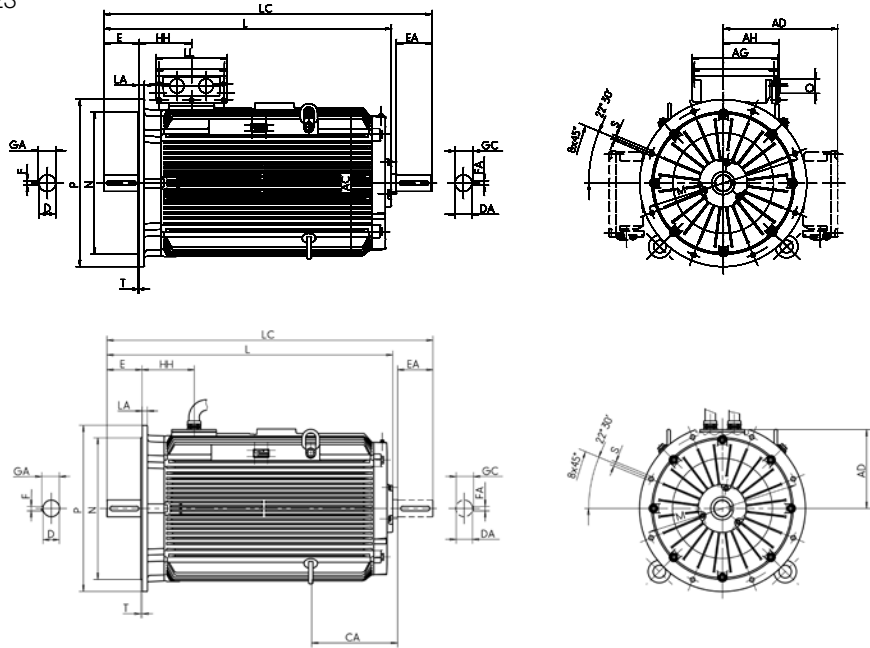

Type designation	Flange size	AC	AD	AD	D	DA	DB ¹⁾	E	EA	F	FA	GA	GC	H	HH	L	LC	TB Type	AG	LL	AH	O	BI
		g	g1	g	d	d1		l	l1	u	u1	t	t1	h	A	k	k1	Standard	x	z	-	r	Bl
IE2-WE1R 315 S2 FAN	FF 600	550	416	315	65	65	M20	140	140	18	18	69	69	315	211	879	1026	200 A	282	242	-	M63 x 1.5	55
IE2-WE1R 315 M2 FAN	FF 600	550	416	315	65	65	M20	140	140	18	18	69	69	315	211	934	1081	200 A	282	242	-	M63 x 1.5	55
IE2-WE1R 315 MX2 FAN	FF 600	550	416	315	65	65	M20	140	140	18	18	69	69	315	211	1014	1161	200 A	282	242	-	M63 x 1.5	55
IE2-WE1R 315 MY2 FAN	FF 600	610	494	348	65	65	M20	140	140	18	18	69	69	315	230	1113	1257	400 B	415	340	265	M63 x 1.5	55
IE2-WE1R 315 L2 FAN	FF 600	610	494	348	65	65	M20	140	140	18	18	69	69	315	230	1233	1377	400 B	415	340	265	M63 x 1.5	55
IE2-WE1R 315 LX2 FAN	FF 600	610	494	348	65	65	M20	140	140	18	18	69	69	315	230	1353	1497	400 B	415	340	265	M63 x 1.5	55
IE2-WE1R 315 S4 FAN	FF 600	550	416	315	80	70	M20	170	140	22	20	85	74.5	315	211	909	1056	200 A	282	242	-	M63 x 1.5	55
IE2-WE1R 315 M4 FAN	FF 600	550	416	315	80	70	M20	170	140	22	20	85	74.5	315	211	964	1111	200 A	282	242	-	M63 x 1.5	55
IE2-WE1R 315 MX4 FAN	FF 600	550	416	315	80	70	M20	170	140	22	20	85	74.5	315	211	1044	1191	200 A	282	242	-	M63 x 1.5	55
IE2-WE1R 315 MY4 FAN	FF 600	610	494	348	80	70	M20	170	140	22	20	85	74.5	315	230	1143	1287	400 B	415	340	265	M63 x 1.5	55
IE2-WE1R 315 L4 FAN	FF 600	610	494	348	80	70	M20	170	140	22	20	85	74.5	315	230	1263	1407	400 B	415	340	265	M63 x 1.5	55
IE2-WE1R 315 LX4 FAN	FF 600	610	494	348	80	70	M20	170	140	22	20	85	74.5	315	230	1383	1527	400 B	415	340	265	M63 x 1.5	55
IE2-WE1R 315 S6 FAN	FF 600	550	416	315	80	70	M20	170	140	22	20	85	74.5	315	211	964	1111	200 A	282	242	-	M63 x 1.5	55
IE2-WE1R 315 M6 FAN	FF 600	550	416	315	80	70	M20	170	140	22	20	85	74.5	315	211	964	1111	200 A	282	242	265	M63 x 1.5	55
IE2-WE1R 315 MX6 FAN	FF 600	610	494	348	80	70	M20	170	140	22	20	85	74.5	315	230	1073	1217	400 B	415	340	265	M63 x 1.5	55
IE2-WE1R 315 MY6 FAN	FF 600	610	494	348	80	70	M20	170	140	22	20	85	74.5	315	230	1073	1217	400 B	415	340	265	M63 x 1.5	55
IE2-WE1R 315 L6 FAN	FF 600	610	494	348	80	70	M20	170	140	22	20	85	74.5	315	230	1263	1407	400 B	415	340	265	M63 x 1.5	55
IE2-WE1R 315 LX6 FAN	FF 600	610	494	348	80	70	M20	170	140	22	20	85	74.5	315	230	1263	1407	400 B	415	340	265	M63 x 1.5	55
IE2-WE1R 315 S8 FAN	FF 600	550	416	315	80	70	M20	170	140	22	20	85	74.5	315	211	909	1056	200 A	282	242	-	M63 x 1.5	55
IE2-WE1R 315 M8 FAN	FF 600	550	416	315	80	70	M20	170	140	22	20	85	74.5	315	211	964	1111	200 A	282	242	-	M63 x 1.5	55
IE2-WE1R 315 MX8 FAN	FF 600	550	416	315	80	70	M20	170	140	22	20	85	74.5	315	211	964	1111	200 A	282	242	-	M63 x 1.5	55
IE2-WE1R 315 MY8 FAN	FF 600	610	494	348	80	70	M20	170	140	22	20	85	74.5	315	230	1143	1287	400 B	415	340	265	M63 x 1.5	55
IE2-WE1R 315 L8 FAN	FF 600	610	494	348	80	70	M20	170	140	22	20	85	74.5	315	230	1263	1407	400 B	415	340	265	M63 x 1.5	55
IE2-WE1R 315 LX8 FAN	FF 600	610	494	348	80	70	M20	170	140	22	20	85	74.5	315	230	1263	1407	400 B	415	340	265	M63 x 1.5	55

¹⁾ Centre holes to DIN 332-DS

Three-phase motors with squirrel-cage rotor for use in powered smoke and heat extraction systems to EN 12101-3
Energy-saving motors, High Efficiency IE2

Surface cooling, type of cooling IC 418, degree of protection IP 55
 Size 355

Type of construction IM B5 [IM 3001]
Type of construction IM V1 [IM 3011]

Flange dimensions, see page 8/23

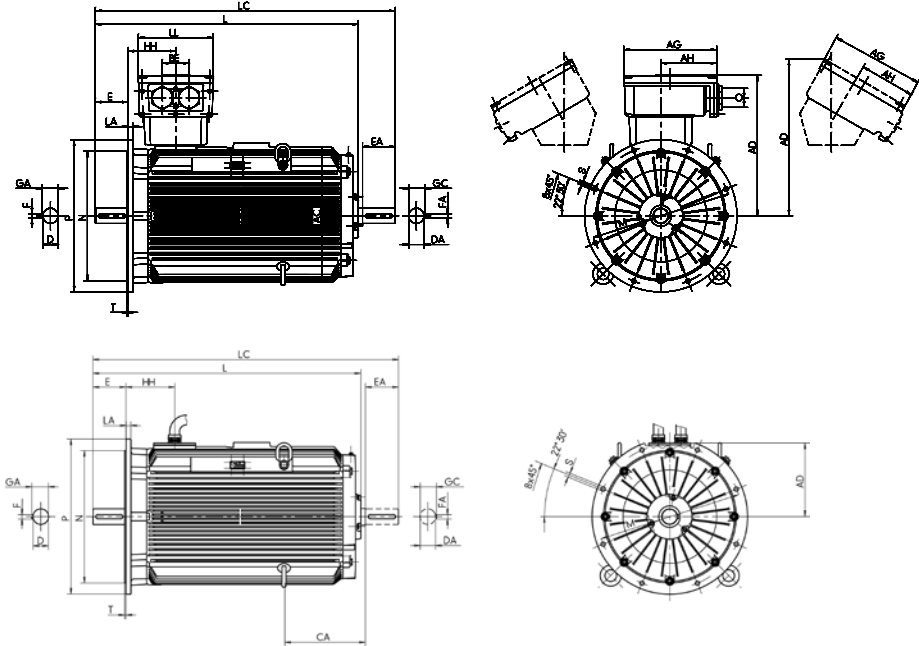

Type designation	Flange size	AC	AD	AD ^{*)}	AD	D	DA	DB ^{*)}	E	EA	F	FA	GA	GC	H	HH	L	LC	TB Type	AG	LL	AH	BE	O	BI
		g	g1	g1	g1	d	d1		l	l1	u	u1	t	t1	h	A	K	K1		x	z	-	-	r	Bl
IE2-WE2R 355 M2	FF 740	715	736	817	484	80	80	M20	170	170	22	22	85	85	355	250	1365	1558	630 A	496	390	301	140	M72 x 2	60
IE2-WE2R 355 M4	FF 740	715	736	817	484	100	80	M24	210	170	28	22	106	85	355	250	1405	1598	630 A	496	390	301	140	M72 x 2	60
IE2-WE2R 355 M6, 8	FF 740	715	736	817	484	100	80	M24	210	170	28	22	106	85	355	250	1405	1598	630 A	496	390	301	140	M72 x 2	60
IE2-WE2R 355 MX6, 8	FF 740	715	736	817	484	100	80	M24	210	170	28	22	106	85	355	250	1525	1718	630 A	496	390	301	140	M72 x 2	60
IE2-WE2R 355 MX2	FF 740	715	728	819	484	80	80	M20	170	170	22	22	85	85	355	327	1485	1678	1000 A	615	474	385	200	M72 x 2	60
IE2-WE2R 355 LY2, L2	FF 740	715	728	819	484	80	80	M20	170	170	22	22	85	85	355	327	1485	1678	1000 A	615	474	385	200	M72 x 2	60
IE2-WE2R 355 MX4	FF 740	715	728	819	484	100	80	M24	210	170	28	22	106	85	355	327	1525	1718	1000 A	615	474	385	200	M72 x 2	60
IE2-WE2R 355 LY, L4	FF 740	715	728	819	484	100	80	M24	210	170	28	22	106	85	355	327	1525	1718	1000 A	615	474	385	200	M72 x 2	60
IE2-WE2R 355 LY6, 8	FF 740	715	728	819	484	100	80	M24	210	170	28	22	106	85	355	327	1525	1718	1000 A	615	474	385	200	M72 x 2	60

^{*)} Centre holes to DIN 332-DS
^{**)} Terminal box inclined left/right

Three-phase motors with squirrel-cage rotor for use in powered smoke and heat extraction systems to EN 12101-3
Energy-saving motor, efficiency class Standard Efficiency IE1

Surface cooling, type of cooling IC 418, degree of protection IP 55
 Size 132 to 280

Type of construction IM B3 [IM 1001]

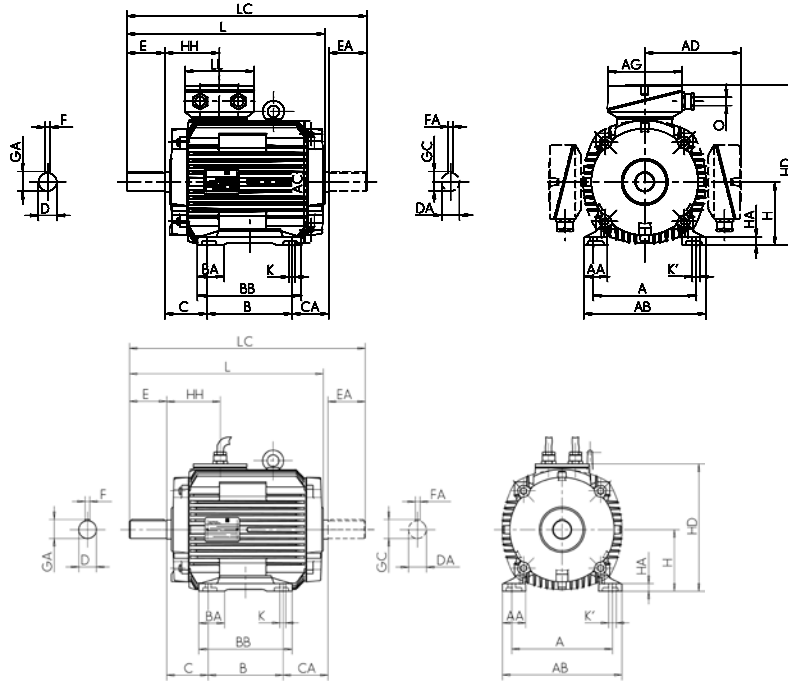

Type designation	Flange size	A	AA	AB	AC	AD	B	BA	BB	C	CA	D	DA	DB ¹⁾	E	EA	F	FA
		b	n	f	g	g1	a	m	e	w1	w2	d	d1		l	l1	u	u1
IE1-K11R 132 M4 FAN	FF265	216	50	256	258	199	178	55	218	89	79	38	38	M12	80	80	10	10
IE1-K11R 132 MX6 FAN	FF265	216	50	256	258	199	178	55	218	89	79	38	38	M12	80	80	10	10
IE1-K11R 160 M2 FAN	FF300	254	55	296	258	214	210	60	257	108	76	42	38	M16	110	80	12	10
IE1-K11R 160 M4, 6, 8 FAN	FF300	254	55	296	258	214	210	60	257	108	76	42	38	M16	110	80	12	10
IE1-K11R 160 MX8 FAN	FF300	254	55	296	258	199	210	60	257	108	76	42	38	M16	110	80	12	10
IE1-K11R 160 MX2 FAN	FF300	254	55	296	313	242	210	60	257	108	87	42	42	M16	110	110	12	12
IE1-K11R 160 L2, 4, 6, 8 FAN	FF300	254	55	296	313	242	254	60	301	108	81	42	42	M16	110	110	12	12
IE1-K11R 180 M2 FAN	FF300	279	62	328	351	261	241	65	288	121	107	48	48	M16	110	110	14	14
IE1-K11R 180 M4 FAN	FF300	279	62	328	313	242	241	65	288	121	81	48	42	M16	110	110	14	12
IE1-K11R 180 L4 FAN	FF300	279	62	328	351	261	279	65	326	121	114	48	48	M16	110	110	14	14
IE1-K11R 180 L6, 8 FAN	FF300	279	62	328	313	242	279	65	326	121	43	48	42	M16	110	110	14	12
IE1-K11R 200 L2, 4, 6, 8 FAN	FF 350	318	70	372	351	261	305	70	360	133	76	55	48	M20	110	110	16	14
IE1-K11R 200 LX6 FAN	FF 350	318	70	372	351	261	305	70	360	133	76	55	48	M20	110	110	16	14
IE1-K11R 200 LX2 FAN	FF 350	318	70	372	390	300	305	70	360	133	139	55	55	M20	110	110	16	16
IE1-K11R 225 S4, 8 FAN	FF 400	356	75	413	390	300	286	75	343	149	148	60	55	M20	140	110	18	16
IE1-K11R 225 M2 FAN	FF 400	356	75	413	390	300	311	75	368	149	157	55	55	M20	110	110	16	16
IE1-K11R 225 M4 FAN	FF 400	356	75	413	390	300	311	75	368	149	157	60	55	M20	140	110	18	16
IE1-K11R 225 M6, 8 FAN	FF 400	356	75	413	390	300	311	75	368	149	117	60	55	M20	140	110	18	16
IE1-K11R 250 M2 FAN	FF 500	406	84	471	440	358	349	84	412	168	90	60	55	M20	140	110	18	16
IE1-K11R 250 M4, 6, 8 FAN	FF 500	406	84	471	440	358	349	84	412	168	90	65	55	M20	140	110	18	16
IE1-K11R 280 S2 FAN	FF 500	457	94	522	490	386	368	96	431	190	113	65	65	M20	140	140	18	18
IE1-K11R 280 S4, 6, 8 FAN	FF 500	457	94	522	490	386	368	96	431	190	113	75	65	M20	140	140	20	18
IE1-K11R 280 M2 FAN	FF 500	457	94	522	490	386	419	96	482	190	108	65	65	M20	140	140	18	18
IE1-K11R 280 M4, 6, 8 FAN	FF 500	457	94	522	490	386	419	96	482	190	108	75	65	M20	140	140	20	18

¹⁾ Centre holes to DIN 332-DS

Three-phase motors with squirrel-cage rotor for use in powered smoke and heat extraction systems to EN 12101-3
Energy-saving motor, efficiency class Standard Efficiency IE1

Surface cooling, type of cooling IC 418, degree of protection IP 55
 Size 132 to 280

Type of construction IM B35 [IM 2001]

Flange dimensions, see page 8/23

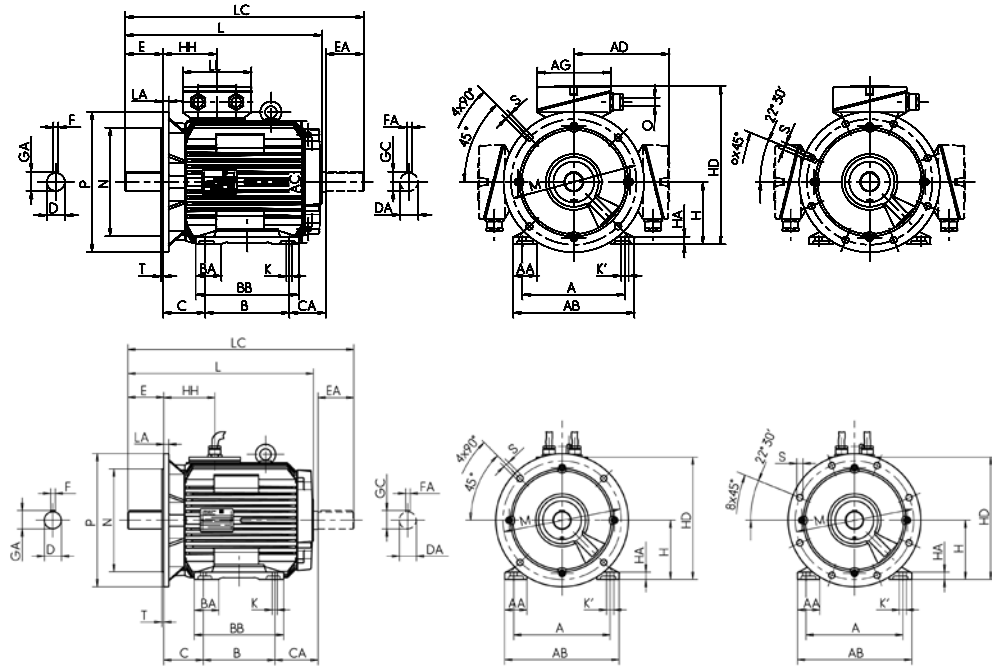

Type designation	GA	GC	H	HA	HD	HD**)	HD	HH	K	K'	L	LC	TB Type	AG	LL	O	Hole
	t	t1	h	c	p	p	p	A	s	s'	k	k1				-	pattern
IE1-K11R 132 M4 FAN	41	41	132	16	331	279	276	114	12	12	420	506	25 A	156	145	M32 x 1.5	4L
IE1-K11R 132 MX6 FAN	41	41	132	16	331	279	276	114	12	12	420	506	25 A	156	145	M32 x 1.5	4L
IE1-K11R 160 M2 FAN	45	41	160	18	374	307	304	114	15	15	498	584	63 A	193	167	M40 x 1.5	4L
IE1-K11R 160 M4, 6, 8 FAN	45	41	160	18	374	307	304	114	15	15	498	584	63 A	193	167	M40 x 1.5	4L
IE1-K11R 160 MX8 FAN	45	41	160	18	374	307	304	114	15	15	498	584	63 A	193	167	M40 x 1.5	4L
IE1-K11R 160 MX2 FAN	45	45	160	18	402	336	332	138	15	20	502	625	63 A	193	167	M40 x 1.5	4L
IE1-K11R 160 L2, 4, 6, 8 FAN	45	45	160	18	402	336	332	138	15	20	540	663	63 A	193	167	M40 x 1.5	4L
IE1-K11R 180 M2 FAN	51.5	51.5	180	20	441	369	371	147	15	20	562	689	63 A	193	167	M40 x 1.5	4L
IE1-K11R 180 M4 FAN	51.5	45	180	20	422	356	352	138	15	20	540	663	63 A	193	167	M40 x 1.5	4L
IE1-K11R 180 L4 FAN	51.5	51.5	180	20	441	369	371	147	15	20	607	734	63 A	193	167	M40 x 1.5	4L
IE1-K11R 180 L6, 8 FAN	51.5	45	180	20	422	369	352	138	15	20	540	663	63 A	193	167	M40 x 1.5	4L
IE1-K11R 200 L2, 4, 6, 8 FAN	59	51.5	200	22	461	389	391	147	19	25	607	734	63 A	193	167	M40 x 1.5	4L
IE1-K11R 200 LX6 FAN	59	51.5	200	22	461	389	391	147	19	25	607	734	63 A	193	167	M40 x 1.5	4L
IE1-K11R 200 LX2 FAN	59	59	200	22	500	417	411	168	19	25	661	797	100 A	213	207	M50 x 1.5	4L
IE1-K11R 225 S4, 8 FAN	64	59	225	25	525	442	436	168	19	25	691	827	100 A	213	207	M50 x 1.5	8L
IE1-K11R 225 M2 FAN	59	59	225	25	525	442	436	168	19	25	701	837	100 A	213	207	M50 x 1.5	8L
IE1-K11R 225 M4 FAN	64	59	225	25	525	442	436	168	19	25	731	867	100 A	213	207	M50 x 1.5	8L
IE1-K11R 225 M6, 8 FAN	64	59	225	25	525	442	436	168	19	25	691	827	100 A	213	207	M50 x 1.5	8L
IE1-K11R 250 M2 FAN	64	59	250	28	608	484	485	177	24	30	737	857	200 A	282	242	M63 x 1.5	8L
IE1-K11R 250 M4, 6, 8 FAN	69	59	250	28	608	484	485	177	24	30	737	857	200 A	282	242	M63 x 1.5	8L
IE1-K11R 280 S2 FAN	69	69	280	32	666	523	565	206	24	30	801	951	200 A	282	242	M63 x 1.5	8L
IE1-K11R 280 S4, 6, 8 FAN	79.5	69	280	32	666	523	565	206	24	30	801	951	200 A	282	242	M63 x 1.5	8L
IE1-K11R 280 M2 FAN	69	69	280	32	666	523	565	206	24	30	847	997	200 A	282	242	M63 x 1.5	8L
IE1-K11R 280 M4, 6, 8 FAN	79.5	69	280	32	666	523	565	206	24	30	847	997	200 A	282	242	M63 x 1.5	8L

***) Terminal box left/right

**Three-phase motors with squirrel-cage rotor for use in powered smoke and heat extraction systems to EN 12101-3
Energy-saving motor, efficiency class Standard Efficiency IE1**

Surface cooling, type of cooling IC 418, degree of protection IP 55
Size 315

Type of construction IM B3 [IM 1001]

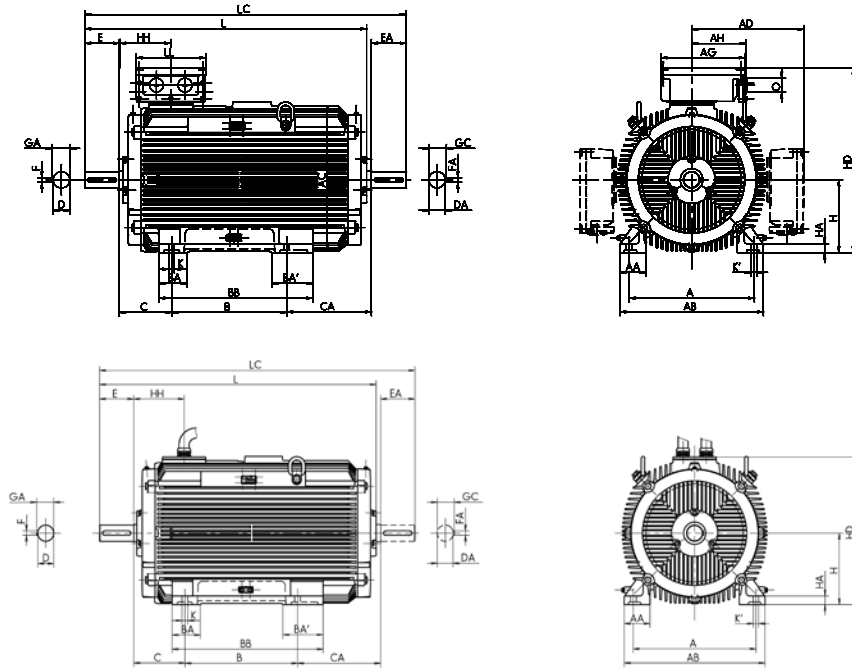

Type designation	Flange size	A	AA	AB	AC	AD	AD	B	BA	BA'	BB	C	CA	D	DA	DB ⁷⁾	E	EA	F	FA
		b	n	f	g	g1	g1	a	m	m1	e	w1	w2	d	d1		l	l1	u	u1
IE1-K11R 315 S2 FAN	FF 600	508	126	590	550	416	315	406	120	-	503	216	124	65	65	M20	140	140	18	18
IE1-K11R 315 S4, 6, 8 FAN	FF 600	508	126	590	550	416	315	406	120	-	503	216	124	80	70	M20	170	140	22	20
IE1-K11R 315 M2 FAN	FF 600	508	126	590	550	416	315	457	120	-	554	216	128	65	65	M20	140	140	18	18
IE1-K11R 315 M4, 6, 8 FAN	FF 600	508	126	590	550	416	315	457	120	-	554	216	128	80	70	M20	170	140	22	20
IE1-K11R 315 MX2 FAN	FF 600	508	126	590	550	416	315	457	120	150	554	216	208	65	65	M20	140	140	18	18
IE1-K11R 315 MX4 FAN	FF 600	508	126	590	550	416	315	457	120	150	554	216	208	80	70	M20	170	140	22	20
IE1-K11R 315 MX6, 8 FAN	FF 600	508	126	590	550	416	315	457	120	150	554	216	128	80	70	M20	170	140	22	20
IE1-K11R 315 MX10, 12 FAN	FF 600	508	126	590	550	416	315	457	120	150	554	216	128	80	70	M20	170	140	22	20
IE1-K11R 315 MY2 FAN	FF 600	508	110	590	610	494	348	457	120	-	573	216	304	65	65	M20	140	140	18	18
IE1-K11R 315 MY4, 6, 8 FAN	FF 600	508	110	590	610	494	348	457	120	-	573	216	304	80	70	M20	170	140	22	20
IE1-K11R 315 L2 FAN	FF 600	508	110	590	610	494	348	508	120	-	624	216	373	65	65	M20	140	140	18	18
IE1-K11R 315 L4, 6, 8 FAN	FF 600	508	110	590	610	494	348	508	120	-	624	216	373	80	70	M20	170	140	22	20
IE1-K11R 315 LX2 FAN	FF 600	508	110	590	610	494	348	508	120	-	624	216	493	65	65	M20	140	140	18	18
IE1-K11R 315 LX4 FAN	FF 600	508	110	590	610	494	348	508	120	-	624	216	493	80	70	M20	170	140	22	20
IE1-K11R 315 LX6, 8 FAN	FF 600	508	110	590	610	494	348	508	120	-	624	216	373	80	70	M20	170	140	22	20

⁷⁾ Centre holes to DIN 332-DS

Three-phase motors with squirrel-cage rotor for use in powered smoke and heat extraction systems to EN 12101-3
Energy-saving motor, efficiency class Standard Efficiency IE1

Surface cooling, type of cooling IC 418, degree of protection IP 55
 Size 315

Type of construction IM B35 [IM 2001]
 Flange dimensions, see page 8/23

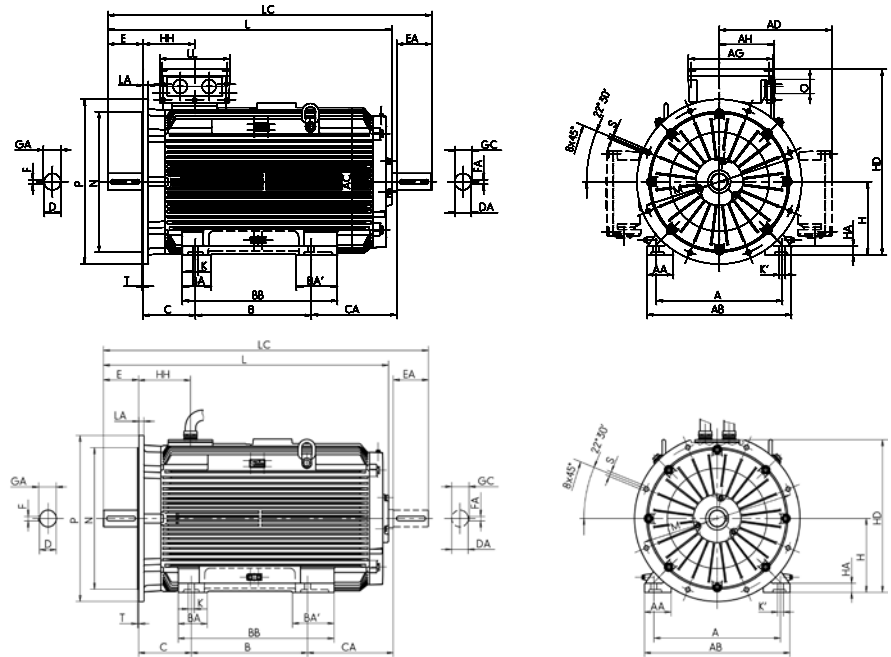

Type designation	GA	GC	H	HA	HD	HD ^{**})	HD	HH	K	K'	L	LC	TB Type	AG	LL	AH	O
	t	tl	h	c	p	p	p	A	s	s'	k	k1				-	
IE1-K11R 315 S2 FAN	69	69	315	44	731	595	630	211	28	35	879	1026	200 A	282	242	-	M63 x 1.5
IE1-K11R 315 S4, 6, 8 FAN	85	74.5	315	44	731	595	630	211	28	35	909	1056	200 A	282	242	-	M63 x 1.5
IE1-K11R 315 M2 FAN	69	69	315	44	731	595	630	211	28	35	934	1081	200 A	282	242	-	M63 x 1.5
IE1-K11R 315 M4, 6, 8 FAN	85	74.5	315	44	731	595	630	211	28	35	964	1111	200 A	282	242	-	M63 x 1.5
IE1-K11R 315 MX2 FAN	69	69	315	44	731	595	630	211	28	35	1014	1161	200 A	282	242	-	M63 x 1.5
IE1-K11R 315 MX4 FAN	85	74.5	315	44	731	595	630	211	28	35	1044	1191	200 A	282	242	-	M63 x 1.5
IE1-K11R 315 MX6, 8 FAN	85	74.5	315	44	731	595	630	211	28	35	964	1111	200 A	282	242	-	M63 x 1.5
IE1-K11R 315 MX10, 12 FAN	85	74.5	315	44	731	595	630	211	28	35	964	1111	200 A	282	242	-	M63 x 1.5
IE1-K11R 315 MY2 FAN	69	69	315	44	809	628	663	230	28	35	1113	1257	400 B	415	340	265	M63 x 1.5
IE1-K11R 315 MY4, 6, 8 FAN	85	74.5	315	44	809	628	663	230	28	35	1143	1287	400 B	415	340	265	M63 x 1.5
IE1-K11R 315 L2 FAN	69	69	315	44	809	628	663	230	28	35	1233	1377	400 B	415	340	265	M63 x 1.5
IE1-K11R 315 L4, 6, 8 FAN	85	74.5	315	44	809	628	663	230	28	35	1263	1407	400 B	415	340	265	M63 x 1.5
IE1-K11R 315 LX2 FAN	69	69	315	44	809	628	663	230	28	35	1353	1497	400 B	415	340	265	M63 x 1.5
IE1-K11R 315 LX4 FAN	85	74.5	315	44	809	628	663	230	28	35	1383	1527	400 B	415	340	265	M63 x 1.5
IE1-K11R 315 LX6, 8 FAN	85	74.5	315	44	809	628	663	230	28	35	1263	1407	400 B	415	340	265	M63 x 1.5

** Terminal box left/right

Three-phase motors with squirrel-cage rotor for use in powered smoke and heat extraction systems to EN 12101-3 Energy-saving motor, efficiency class Standard Efficiency IE1

Surface cooling, type of cooling IC 418, degree of protection IP 55
Size 355

Type of construction IM B3 [IM 1001]

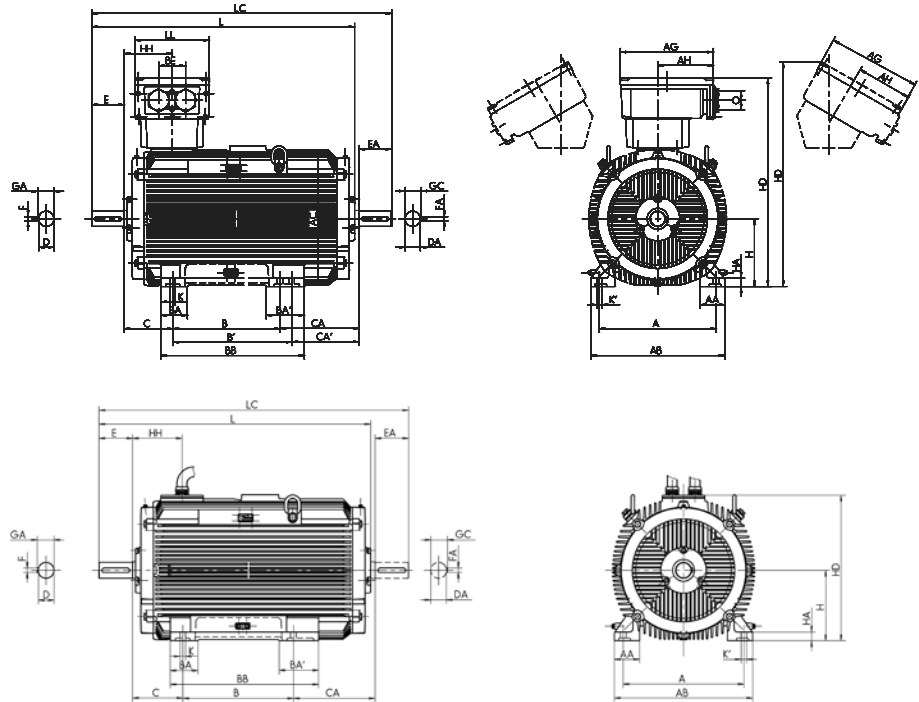

Type designation	Flange size	A	AA	AB	AC	B	BA	BA'	BB	C	CA	D	DA	DB ¹⁾	E	EA	F	FA
		b	n	f	g	a	m	m1	e	w1	w2	d	d1		l	l1	u	u1
IE1-K22R 355 MY2, M2 FAN	FF 740	610	130	700	715	560	140	200	750	254	404	80	80	M20	170	170	22	22
IE1-K22R 355 MY4, 6, 8 FAN	FF 740	610	130	700	715	560	140	200	750	254	404	100	80	M24	210	170	28	22
IE1-K22R 355 M4 FAN	FF 740	610	130	700	715	560	140	200	750	254	404	100	80	M24	210	170	28	22
IE1-K22R 355 M6, 8 FAN	FF 740	610	130	700	715	560	140	200	750	254	404	100	80	M24	210	170	28	22
IE1-K22R 355 MX6, 8 FAN	FF 740	610	130	700	715	560	140	200	750	254	524	100	80	M24	210	170	28	22
IE1-K22R 355 MX2 FAN	FF 740	610	130	700	715	560	140	200	750	254	524	80	80	M20	170	170	22	22
IE1-K22R 355 LY2, L2 FAN	FF 740	610	130	700	715	630	140	200	750	254	454	80	80	M20	170	170	22	22
IE1-K22R 355 MX4 FAN	FF 740	610	130	700	715	560	140	200	750	254	524	100	80	M24	210	170	28	22
IE1-K22R 355 LY4, 6, 8, L4 FAN	FF 740	610	130	700	715	630	140	200	750	254	454	100	80	M24	210	170	28	22

¹⁾ Centre holes to DIN 332-DS

Three-phase motors with squirrel-cage rotor for use in powered smoke and heat extraction systems to EN 12101-3
Energy-saving motor, efficiency class Standard Efficiency IE1

Surface cooling, type of cooling IC 418, degree of protection IP 55
 Size 355

Type of construction IM B35 [IM 1001]

Flange dimensions, see page 8/23

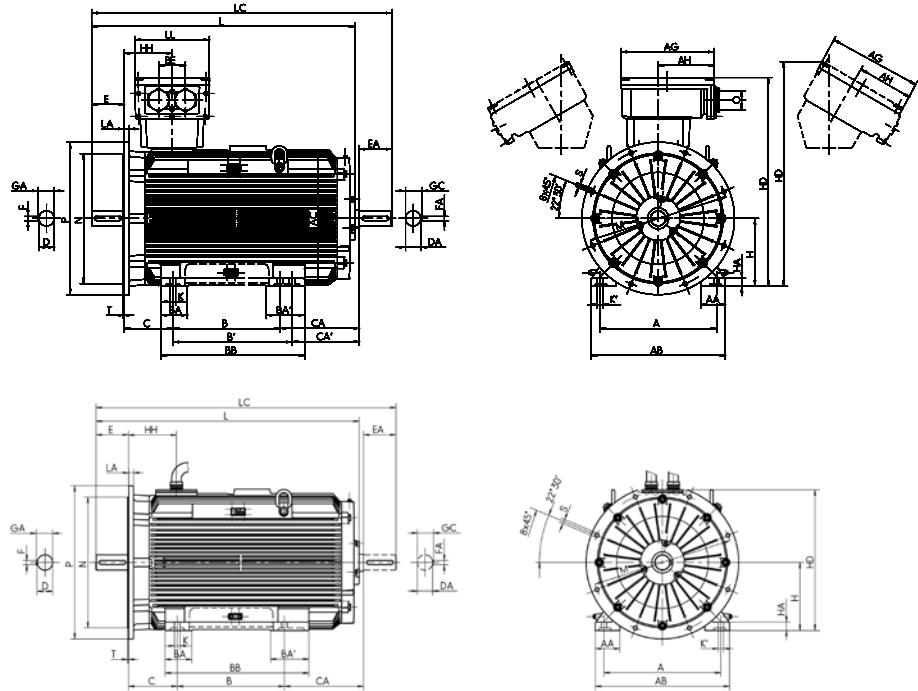

Type designation	GA	GC	H	HA	HD	HD ^{*)}	HD	HH	K	K'	L	LC	TB Type	AG	LL	AH	BE	O
	t	t1	h	c	p	p	p	A	s	s'	k	k1		x	z	-	-	r
IE1-K22R 355 MY2, M2 FAN	85	85	355	44	1091	1172	839	250	28	35	1365	1558	630 A	496	390	301	140	M72 x 2
IE1-K22R 355 MY4, 6, 8 FAN	106	85	355	44	1091	1172	839	250	28	35	1405	1598	630 A	496	390	301	140	M72 x 2
IE1-K22R 355 M4 FAN	106	85	355	44	1091	1172	839	250	28	35	1405	1598	630 A	496	390	301	140	M72 x 2
IE1-K22R 355 M6, 8 FAN	106	85	355	44	1091	1172	839	250	28	35	1405	1598	630 A	496	390	301	140	M72 x 2
IE1-K22R 355 MX6, 8 FAN	106	85	355	44	1091	1172	839	250	28	35	1525	1718	630 A	496	390	301	140	M72 x 2
IE1-K22R 355 MX2 FAN	85	85	355	44	1083	1174	839	327	28	35	1485	1678	1000 A	615	474	385	200	M72 x 2
IE1-K22R 355 LY2, L2 FAN	85	85	355	44	1083	1174	839	327	28	35	1485	1678	1000 A	615	474	385	200	M72 x 2
IE1-K22R 355 MX4 FAN	106	85	355	44	1083	1174	839	327	28	35	1525	1718	1000 A	615	474	385	200	M72 x 2
IE1-K22R 355 LY4, 6, 8, L4 FAN	106	85	355	44	1083	1174	839	327	28	35	1525	1718	1000 A	615	474	385	200	M72 x 2

^{*)} Terminal box inclined left/right

Three-phase motors with squirrel-cage rotor for use in powered smoke and heat extraction systems to EN 12101-3
Energy-saving motor, efficiency class Standard Efficiency IE1

Surface cooling, type of cooling IC 418, degree of protection IP 55
 Size 132 to 180

Type of construction IM B14 [IM 3601]

Flange dimensions, see page 8/23

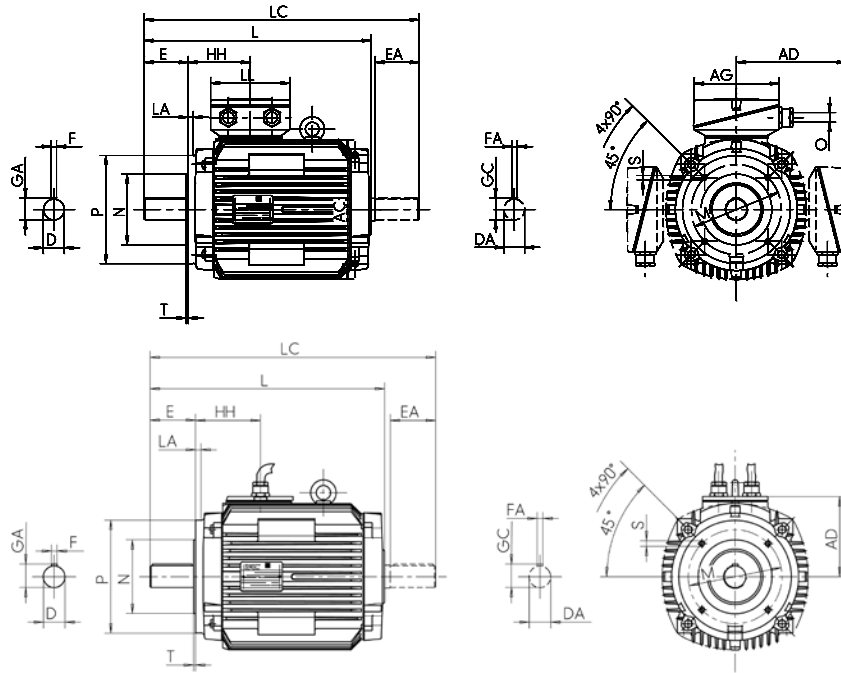

Type designation	Flange size		A	AA	AB	AC	AD	AD	B	BA	BB	C	CA	D	DA	DB ¹⁾	E	EA	F	FA
	small	large	b	n	f	g	g1	g1	a	m	e	w1	w2	d	d1		l	l1	u	u1
IE1-K11R 132 M4 FAN	FT 165	FT 215	216	50	256	258	199	144	178	55	218	89	79	38	38	M12	80	80	10	10
IE1-K11R 132 MX6 FAN	FT 165	FT 215	216	50	256	258	199	144	178	55	218	89	79	38	38	M12	80	80	10	10
IE1-K11R 160 M2 FAN	FT 165	FT 215	254	55	296	258	214	144	210	60	257	108	76	42	38	M16	110	80	12	10
IE1-K11R 160 M4, 6, 8 FAN	FT 165	FT 215	254	55	296	258	214	144	210	60	257	108	76	42	38	M16	110	80	12	10
IE1-K11R 160 MX8 FAN	FT 165	FT 215	254	55	296	258	199	144	210	60	257	108	76	42	38	M16	110	80	12	10
IE1-K11R 160 MX2 FAN	FT 215	FT 265	254	55	296	313	242	172	210	60	257	108	87	42	42	M16	110	110	12	12
IE1-K11R 160 L2, 4, 6, 8 FAN	FT 215	FT 265	254	55	296	313	242	172	254	60	301	108	81	42	42	M16	110	110	12	12
IE1-K11R 180 M4 FAN	FT 265	-	279	62	328	313	242	172	241	65	288	121	81	48	42	M16	110	110	14	12
IE1-K11R 180 L6, 8 FAN	FT 265	-	279	62	328	313	242	172	279	65	326	121	43	48	42	M16	110	110	14	12

¹⁾ Centre holes to DIN 332-DS

Three-phase motors with squirrel-cage rotor for use in powered smoke and heat extraction systems to EN 12101-3
Energy-saving motor, efficiency class Standard Efficiency IE1

Surface cooling, type of cooling IC 418, degree of protection IP 55
 Size 132 to 180

Type of construction IM B34 [IM 2101]

Flange dimensions, see page 8/23

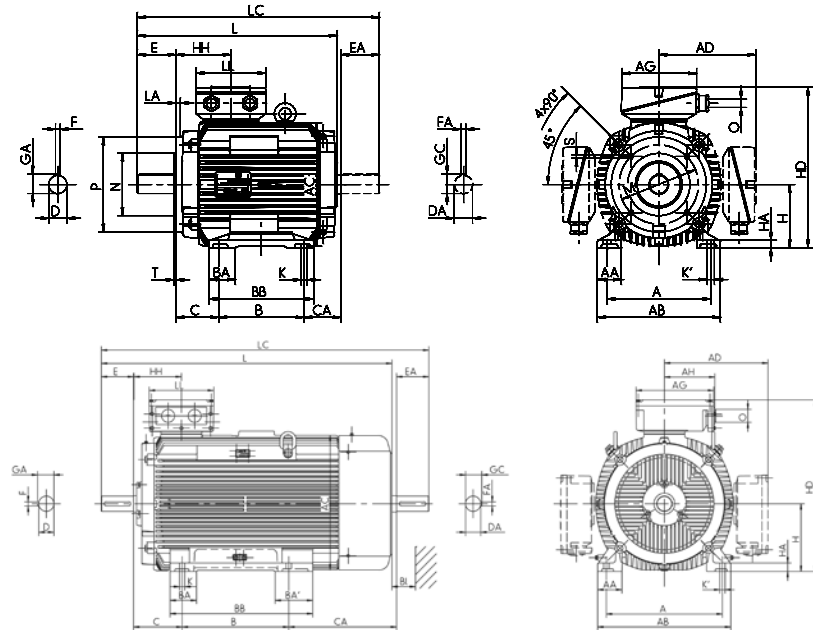

Type designation	GA	GC	H	HA	HD	HD **)	HD	HH	K	K'	L	LC	TB Type	AG	LL	O
	t	t1	h	c	p	p	p	A	s	s'	k	k1				
IE1-K11R 132 M4 FAN	41	41	132	16	331	279	276	114	12	12	420	506	25 A	156	145	M32 x 1.5
IE1-K11R 132 MX6 FAN	41	41	132	16	331	279	276	114	12	12	420	506	25 A	156	145	M32 x 1.5
IE1-K11R 160 M2 FAN	45	41	160	18	374	307	304	114	15	15	498	584	63 A	193	167	M40 x 1.5
IE1-K11R 160 M4, 6, 8 FAN	45	41	160	18	374	307	304	114	15	15	498	584	63 A	193	167	M40 x 1.5
IE1-K11R 160 MX8 FAN	45	41	160	18	374	307	304	114	15	15	498	584	63 A	193	167	M40 x 1.5
IE1-K11R 160 MX2 FAN	45	45	160	18	402	336	332	138	15	20	502	625	63 A	193	167	M40 x 1.5
IE1-K11R 160 L2, 4, 6, 8 FAN	45	45	160	18	402	336	332	138	15	20	540	663	63 A	193	167	M40 x 1.5
IE1-K11R 180 M4 FAN	51.5	45	180	20	422	369	352	138	15	20	540	663	63 A	193	167	M40 x 1.5
IE1-K11R 180 L6, 8 FAN	51.5	45	180	20	422	369	352	138	15	20	540	663	63 A	193	167	M40 x 1.5

**) Terminal box left/right

Three-phase motors with squirrel-cage rotor for use in powered smoke and heat extraction systems to EN 12101-3
Energy-saving motor, efficiency class Standard Efficiency IE1

Surface cooling, type of cooling IC 418, degree of protection IP 55
 Size 132 to 280

Type of construction IM B5 [IM 3001]
Type of construction IM V1 [IM 3011]

Flange dimensions, see page 8/23

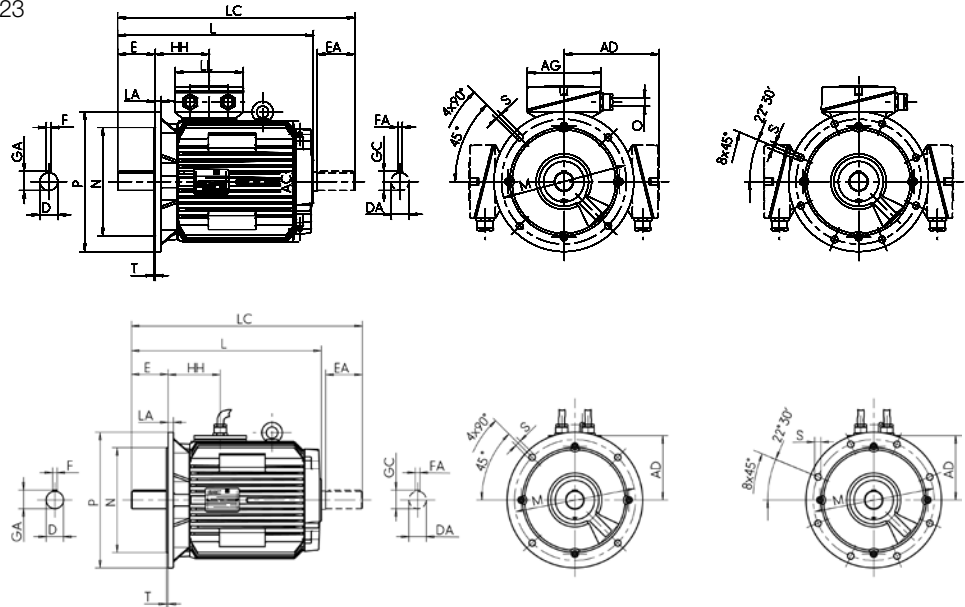

Type designation	Flange size	AC	AD	AD	D	DA	DB ^{*)}	E	EA	F	FA	GA	GC	H	HH	L	LC	TB	Type	AG	LL	O	Hole
		g	g1	g1	d	d1		l	l1	u	u1	t	t1	h	A	k	k1						pattern
IE1-K11R 132 M4 FAN	FF265	258	199	144	38	38	M12	80	80	10	10	41	41	132	114	420	506	25 A	156	145	M32 x 1.5	4L	
IE1-K11R 132 MX6 FAN	FF265	258	199	144	38	38	M12	80	80	10	10	41	41	132	114	420	506	25 A	156	145	M32 x 1.5	4L	
IE1-K11R 160 M2 FAN	FF300	258	214	144	42	38	M16	110	80	12	10	45	41	160	114	498	584	63 A	193	167	M40 x 1.5	4L	
IE1-K11R 160 M4, 6, 8 FAN	FF300	258	214	144	42	38	M16	110	80	12	10	45	41	160	114	498	584	63 A	193	167	M40 x 1.5	4L	
IE1-K11R 160 MX8 FAN	FF300	258	199	144	42	38	M16	110	80	12	10	45	41	160	114	498	584	63 A	193	167	M40 x 1.5	4L	
IE1-K11R 160 MX2 FAN	FF300	313	242	172	42	42	M16	110	110	12	12	45	45	160	138	502	625	63 A	193	167	M40 x 1.5	4L	
IE1-K11R 160 L2, 4, 6, 8 FAN	FF300	313	242	172	42	42	M16	110	110	12	12	45	45	160	138	540	663	63 A	193	167	M40 x 1.5	4L	
IE1-K11R 180 M2 FAN	FF300	351	261	191	48	48	M16	110	110	14	14	51.5	51.5	180	147	562	689	63 A	193	167	M40 x 1.5	4L	
IE1-K11R 180 M4 FAN	FF300	313	242	172	48	42	M16	110	110	14	12	51.5	45	180	138	540	663	63 A	193	167	M40 x 1.5	4L	
IE1-K11R 180 L4 FAN	FF300	351	261	191	48	48	M16	110	110	14	14	51.5	51.5	180	147	607	734	63 A	193	167	M40 x 1.5	4L	
IE1-K11R 180 L6, 8 FAN	FF300	313	242	172	48	42	M16	110	110	14	12	51.5	45	180	138	540	663	63 A	193	167	M40 x 1.5	4L	
IE1-K11R 200 L2, 4, 6, 8 FAN	FF 350	351	261	191	55	48	M20	110	110	16	14	59	51.5	200	147	607	734	63 A	193	167	M40 x 1.5	4L	
IE1-K11R 200 LX6 FAN	FF 350	351	261	191	55	48	M20	110	110	16	14	59	51.5	200	147	607	734	63 A	193	167	M40 x 1.5	4L	
IE1-K11R 200 LX2 FAN	FF 350	390	300	211	55	55	M20	110	110	16	16	64	59	200	168	661	797	100 A	213	207	M50 x 1.5	4L	
IE1-K11R 225 S4, 8 FAN	FF 400	390	300	211	60	55	M20	140	110	18	16	64	59	225	168	691	827	100 A	213	207	M50 x 1.5	8L	
IE1-K11R 225 M2 FAN	FF 400	390	300	211	55	55	M20	110	110	16	16	59	59	225	168	701	837	100 A	213	207	M50 x 1.5	8L	
IE1-K11R 225 M4 FAN	FF 400	390	300	211	60	55	M20	140	110	18	16	64	59	225	168	731	867	100 A	213	207	M50 x 1.5	8L	
IE1-K11R 225 M6, 8 FAN	FF 400	390	300	211	60	55	M20	140	110	18	16	64	59	225	168	691	827	100 A	213	207	M50 x 1.5	8L	
IE1-K11R 250 M2 FAN	FF 500	440	358	235	60	55	M20	140	110	18	16	64	59	250	177	737	857	200 A	282	242	M63 x 1.5	8L	
IE1-K11R 250 M4, 6, 8 FAN	FF 500	440	358	235	65	55	M20	140	110	18	16	69	59	250	177	737	857	200 A	282	242	M63 x 1.5	8L	
IE1-K11R 280 S2 FAN	FF 500	490	386	285	65	65	M20	140	140	18	18	69	69	280	206	801	951	200 A	282	242	M63 x 1.5	8L	
IE1-K11R 280 S4, 6, 8 FAN	FF 500	490	386	285	75	65	M20	140	140	20	18	79.5	69	280	206	801	951	200 A	282	242	M63 x 1.5	8L	
IE1-K11R 280 M2 FAN	FF 500	490	386	285	65	65	M20	140	140	18	18	69	69	280	206	847	997	200 A	282	242	M63 x 1.5	8L	
IE1-K11R 280 M4, 6, 8 FAN	FF 500	490	386	285	75	65	M20	140	140	20	18	79.5	69	280	206	847	997	200 A	282	242	M63 x 1.5	8L	

^{*)} Centre holes to DIN 332-DS
^{**)} Terminal box left/right

Three-phase motors with squirrel-cage rotor for use in powered smoke and heat extraction systems to EN 12101-3
Energy-saving motor, efficiency class Standard Efficiency IE1

Surface cooling, type of cooling IC 418, degree of protection IP 55
 Size 315

Type of construction IM B5 [IM 3001]
Type of construction IM V1 [IM 3011]

Flange dimensions, see page 8/23

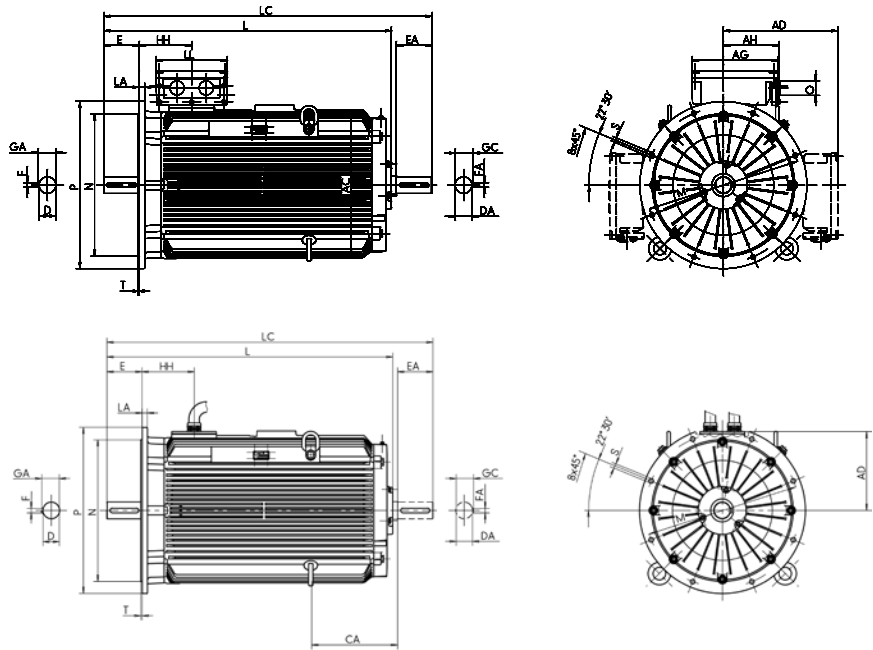

Type designation	Flange size	AC	AD	AD	D	DA	DB ¹⁾	E	EA	F	FA	GA	GC	H	HH	L	LC	TB Type	AG	LL	AH	O
		g	g1	g1	d	d1		l	l1	u	u1	t	t1	h	A	k	k1		x	z	-	r
IE1-K11R 315 S2	FF 600	550	416	315	65	65	M20	140	140	18	18	69	69	315	211	879	1026	200 A	282	242	-	M63 x 1.5
IE1-K11R 315 S4, 6, 8	FF 600	550	416	315	80	70	M20	170	140	22	20	85	74.5	315	211	909	1056	200 A	282	242	-	M63 x 1.5
IE1-K11R 315 M2	FF 600	550	416	315	65	65	M20	140	140	18	18	69	69	315	211	934	1081	200 A	282	242	-	M63 x 1.5
IE1-K11R 315 M4, 6, 8	FF 600	550	416	315	80	70	M20	170	140	22	20	85	74.5	315	211	964	1111	200 A	282	242	-	M63 x 1.5
IE1-K11R 315 MX2	FF 600	550	416	315	65	65	M20	140	140	18	18	69	69	315	211	1014	1161	200 A	282	242	-	M63 x 1.5
IE1-K11R 315 MX4	FF 600	550	416	315	80	70	M20	170	140	22	20	85	74.5	315	211	1044	1191	200 A	282	242	-	M63 x 1.5
IE1-K11R 315 MX6, 8	FF 600	550	416	315	80	70	M20	170	140	22	20	85	74.5	315	211	964	1111	200 A	282	242	-	M63 x 1.5
IE1-K11R 315 MX10, 12	FF 600	550	416	315	80	70	M20	170	140	22	20	85	74.5	315	211	964	1111	200 A	282	242	-	M63 x 1.5
IE1-K11R 315 MY2	FF 600	610	494	348	65	65	M20	140	140	18	18	69	69	315	230	1113	1257	400 B	415	340	265	M63 x 1.5
IE1-K11R 315 MY4, 6, 8	FF 600	610	494	348	80	70	M20	170	140	22	20	85	74.5	315	230	1143	1287	400 B	415	340	265	M63 x 1.5
IE1-K11R 315 L2	FF 600	610	494	348	65	65	M20	140	140	18	18	69	69	315	230	1233	1377	400 B	415	340	265	M63 x 1.5
IE1-K11R 315 L4, 6, 8	FF 600	610	494	348	80	70	M20	170	140	22	20	85	74.5	315	230	1263	1407	400 B	415	340	265	M63 x 1.5
IE1-K11R 315 LX2	FF 600	610	494	348	65	65	M20	140	140	18	18	69	69	315	230	1353	1497	400 B	415	340	265	M63 x 1.5
IE1-K11R 315 LX4	FF 600	610	494	348	80	70	M20	170	140	22	20	85	74.5	315	230	1383	1527	400 B	415	340	265	M63 x 1.5
IE1-K11R 315 LX6, 8	FF 600	610	494	348	80	70	M20	170	140	22	20	85	74.5	315	230	1263	1407	400 B	415	340	265	M63 x 1.5

¹⁾ Centre holes to DIN 332-DS

Three-phase motors with squirrel-cage rotor for use in powered smoke and heat extraction systems to EN 12101-3
Energy-saving motor, efficiency class Standard Efficiency IE1

Surface cooling, type of cooling IC 418, degree of protection IP 55
 Size 355

Type of construction IM B5 [IM 3001]
Type of construction IM V1 [IM 3011]

Flange dimensions, see page 8/23

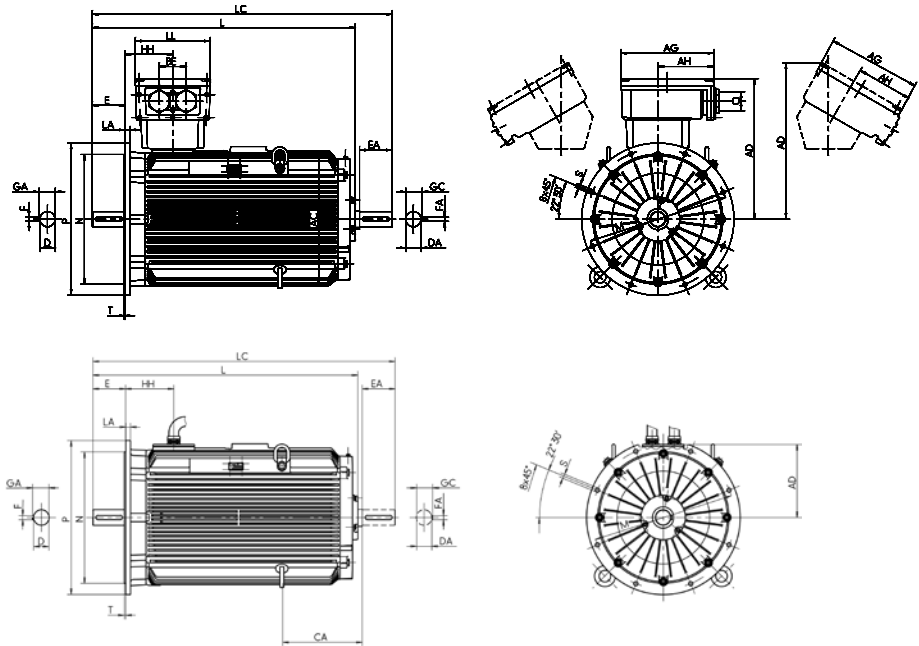

Type designation	Flange size	AC	AD	AD ¹⁾	AD	D	DA	DB ¹⁾	E	EA	F	FA	GA	GC	H	HH	L	LC	TB Type	AG	LL	AH	BE	O
		g	g1	g1	g1	d	d1		l	l1	u	u1	t	t1	h	A	k	k1		x	z	-	-	r
IE1-K22R 355 MY2, M2	FF 740	715	736	817	484	80	80	M20	170	170	22	22	85	85	355	250	1365	1558	630 A	496	390	301	140	M72 x 2
IE1-K22R 355 MY4, 6, 8	FF 740	715	736	817	484	100	80	M24	210	170	28	22	106	85	355	250	1405	1598	630 A	496	390	301	140	M72 x 2
IE1-K22R 355 M4	FF 740	715	736	817	484	100	80	M24	210	170	28	22	106	85	355	250	1405	1598	630 A	496	390	301	140	M72 x 2
IE1-K22R 355 M6, 8	FF 740	715	736	817	484	100	80	M24	210	170	28	22	106	85	355	250	1405	1598	630 A	496	390	301	140	M72 x 2
IE1-K22R 355 MX6, 8	FF 740	715	736	817	484	100	80	M24	210	170	28	22	106	85	355	250	1525	1718	630 A	496	390	301	140	M72 x 2
IE1-K22R 355 MX2	FF 740	715	728	819	484	80	80	M20	170	170	22	22	85	85	355	327	1485	1678	1000 A	615	474	385	200	M72 x 2
IE1-K22R 355 LY2,L2	FF 740	715	728	819	484	80	80	M20	170	170	22	22	85	85	355	327	1485	1678	1000 A	615	474	385	200	M72 x 2
IE1-K22R 355 MX4	FF 740	715	728	819	484	100	80	M24	210	170	28	22	106	85	355	327	1525	1718	1000 A	615	474	385	200	M72 x 2
IE1-K22R 355 LY4, 6, 8, L4	FF 740	715	728	819	484	100	80	M24	210	170	28	22	106	85	355	327	1525	1718	1000 A	615	474	385	200	M72 x 2

¹⁾ Centre holes to DIN 332-DS
²⁾ Terminal box inclined left/right

Three-phase motors with squirrel-cage rotor for use in powered smoke and heat extraction systems to EN 12101-3 Energy-saving motor, efficiency class Standard Efficiency IE1

Surface cooling, type of cooling IC 418, degree of protection IP 55
Size 132 to 250

Type of construction IM B3 [IM 1001]

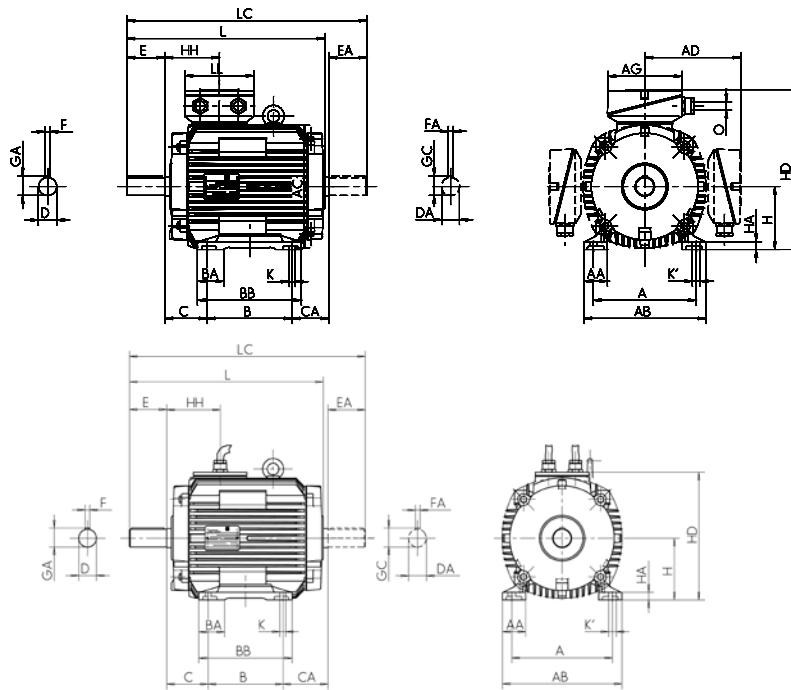

Type designation	Flange size	A	AA	AB	AC	AD	AD	B	BA	BB	C	CA	D	DA	DB ¹⁾	E	EA	F	FA
		b	n	f	g	g1	g1	a	m	e	w1	w2	d	d1		l	l1	u	u1
IE1-K10R 132 S FAN	FF 300	216	50	256	258	199	140	140	52.5	180	89	117	38	38	M12	80	80	10	10
IE1-K10R 132 M FAN	FF 300	216	50	256	258	199	140	178	52.5	218	89	127	38	38	M12	80	80	10	10
IE1-K10R 160 S2 FAN	FF 300	254	55	296	313	242	169	178	56	225	108	119	42	42	M16	110	110	12	12
IE1-K10R 160 S4, 6, 8 FAN	FF 300	254	55	296	313	242	169	178	56	225	108	119	48	42	M16	110	110	14	12
IE1-K10R 160 M2 FAN	FF 300	254	55	296	313	242	169	210	56	257	108	125	42	42	M16	110	110	12	12
IE1-K10R 160 M4, 6, 8 FAN	FF 300	254	55	296	313	242	169	210	56	257	108	125	48	42	M16	110	110	14	12
IE1-K10R 180 S2 FAN	FF 350	279	62	328	351	261	187	203	65	250	121	145	48	48	M16	110	110	14	14
IE1-K10R 180 S4, 6, 8 FAN	FF 350	279	62	328	351	261	187	203	65	250	121	145	55	48	M20	110	110	16	14
IE1-K10R 180 M2 FAN	FF 350	279	62	328	351	261	187	241	65	288	121	152	48	48	M16	110	110	14	14
IE1-K10R 180 M4, 6, 8 FAN	FF 350	279	62	328	351	261	187	241	65	288	121	152	55	48	M20	110	110	16	14
IE1-K10R 200 M2 FAN	FF 400	318	70	372	390	300	209	267	70	322	133	177	55	55	M20	110	110	16	16
IE1-K10R 200 M4, 6, 8 FAN	FF 400	318	70	372	390	300	209	267	70	322	133	177	60	55	M20	140	110	18	16
IE1-K10R 200 L2 FAN	FF 400	318	70	372	390	300	209	305	70	360	133	179	55	55	M20	110	110	16	16
IE1-K10R 200 L4, 6, 8 FAN	FF 400	318	70	372	390	300	209	305	70	360	133	179	60	55	M20	140	110	18	16
IE1-K10R 225 M2 FAN	FF 500	356	75	413	440	324	233	311	75	368	149	147	55	55	M20	110	110	16	16
IE1-K10R 225 M4, 6, 8 FAN	FF 500	356	75	413	440	324	233	311	75	368	149	147	65	55	M20	140	110	18	16
IE1-K10R 250 S2 FAN	FF 500	406	84	469	490	386	263	311	84	374	168	192	65	65	M20	140	140	18	18
IE1-K10R 250 S4, 6, 8 FAN	FF 500	406	84	469	490	386	263	311	84	374	168	192	75	65	M20	140	140	20	18
IE1-K10R 250 M2 FAN	FF 500	406	84	469	490	386	263	349	84	412	168	154	65	65	M20	140	140	18	18
IE1-K10R 250 M4 FAN	FF 500	406	84	469	490	386	263	349	84	412	168	200	75	65	M20	140	140	20	18
IE1-K10R 250 M6, 8 FAN	FF 500	406	84	469	490	386	263	349	84	412	168	154	65	65	M20	140	140	18	18

¹⁾ Centre holes to DIN 332-DS

Three-phase motors with squirrel-cage rotor for use in powered smoke and heat extraction systems to EN 12101-3
Energy-saving motor, efficiency class Standard Efficiency IE1

Surface cooling, type of cooling IC 418, degree of protection IP 55
 Size 132 to 250
 Size 132 to 160 with crowned flange

Type of construction IM B35 [IM 2001]

Flange dimensions, see page 8/23

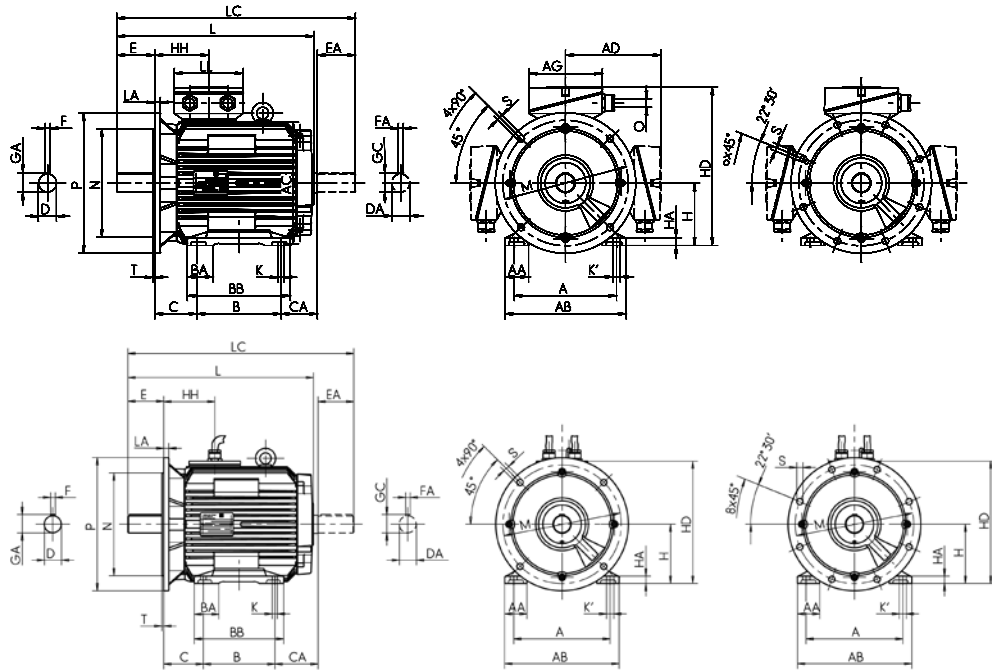

Type designation	GA	GC	H	HA	HD	HD ^{*)}	HD	HD ^{*)}	HH	K	K'	L	LC	TB Type	AG	LL	O	Hole
	t	t1	h	c	p	p	p	p	A	s	s'	k	k1					pattern
IE1-K10R 132 S FAN	41	41	132	15	331	279	276	279	114	12	12	420	506	25 A	156	145	M32 x 1.5	4L
IE1-K10R 132 M FAN	41	41	132	15	331	279	276	279	114	12	12	468	554	25 A	156	145	M32 x 1.5	4L
IE1-K10R 160 S2 FAN	45	45	160	18	402	336	332	336	138	15	20	502	625	63 A	193	167	M40 x 1.5	4L
IE1-K10R 160 S4, 6, 8 FAN	51.5	45	160	18	402	336	332	336	138	15	20	502	625	63 A	193	167	M40 x 1.5	4L
IE1-K10R 160 M2 FAN	45	45	160	18	402	336	332	336	138	15	20	540	663	63 A	193	167	M40 x 1.5	4L
IE1-K10R 160 M4, 6, 8 FAN	51.5	45	160	18	402	336	332	336	138	15	20	540	663	63 A	193	167	M40 x 1.5	4L
IE1-K10R 180 S2 FAN	51.5	51.5	180	20	441	369	371	369	147	15	20	562	689	63 A	193	167	M40 x 1.5	4L
IE1-K10R 180 S4, 6, 8 FAN	59	51.5	180	20	441	369	371	369	147	15	20	562	689	63 A	193	167	M40 x 1.5	4L
IE1-K10R 180 M2 FAN	51.5	51.5	180	20	441	369	371	369	147	15	20	607	734	63 A	193	167	M40 x 1.5	4L
IE1-K10R 180 M4, 6, 8 FAN	59	51.5	180	20	441	369	371	369	147	15	20	607	734	63 A	193	167	M40 x 1.5	4L
IE1-K10R 200 M2 FAN	59	59	200	22	500	417	411	417	168	19	25	661	797	100 A	213	207	M50 x 1.5	4L
IE1-K10R 200 M4, 6, 8 FAN	64	59	200	22	500	417	411	417	168	19	25	691	827	100 A	213	207	M50 x 1.5	4L
IE1-K10R 200 L2 FAN	59	59	200	22	500	417	411	417	168	19	25	701	837	100 A	213	207	M50 x 1.5	4L
IE1-K10R 200 L4, 6, 8 FAN	64	59	200	22	500	417	411	417	168	19	25	731	867	100 A	213	207	M50 x 1.5	4L
IE1-K10R 225 M2 FAN	59	59	225	25	549	459	460	459	177	19	25	707	827	100 A	213	207	M50 x 1.5	8L
IE1-K10R 225 M4, 6, 8 FAN	69	59	225	25	549	459	460	459	177	19	25	737	857	100 A	213	207	M50 x 1.5	8L
IE1-K10R 250 S2 FAN	69	69	250	28	636	493	513	493	206	24	30	801	951	200 A	213	207	M63 x 1.5	8L
IE1-K10R 250 S4, 6, 8 FAN	79.5	69	250	28	636	493	513	493	206	24	30	801	951	200 A	213	207	M63 x 1.5	8L
IE1-K10R 250 M2 FAN	69	69	250	28	636	493	513	493	206	24	30	801	951	200 A	213	207	M63 x 1.5	8L
IE1-K10R 250 M4 FAN	79.5	69	250	28	636	493	513	493	206	24	30	847	997	200 A	213	207	M63 x 1.5	8L
IE1-K10R 250 M6, 8 FAN	69	69	250	28	636	493	513	493	206	24	30	801	951	200 A	213	207	M63 x 1.5	8L

**) Terminal box left/right

**Three-phase motors with squirrel-cage rotor for use in powered smoke and heat extraction systems to EN 12101-3
Energy-saving motor, efficiency class Standard Efficiency IE1**

Surface cooling, type of cooling IC 418, degree of protection IP 55
Size 280, 315

Type of construction IM B3 [IM 1001]

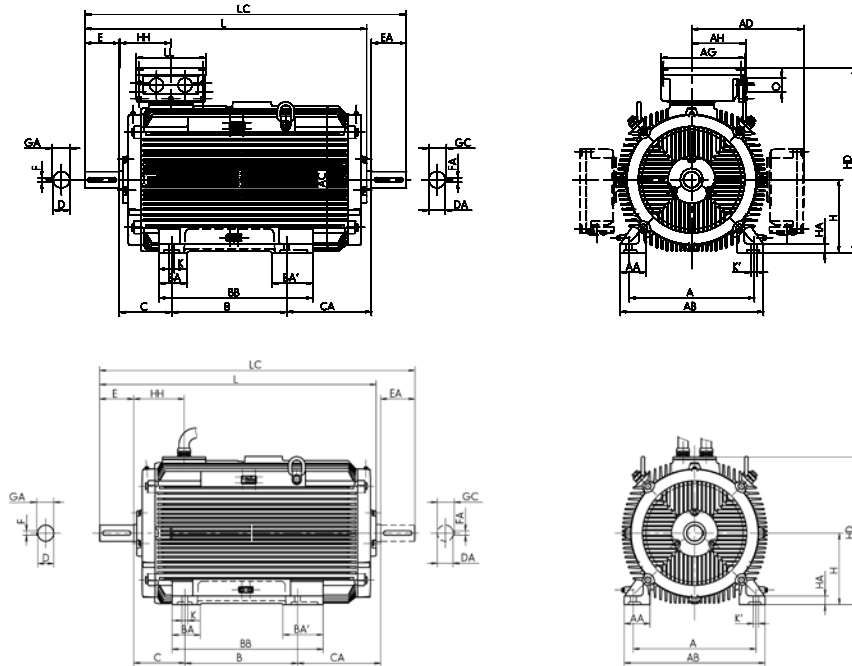

Type designation	Flange size	A	AA	AB	AC	AD	B	BA	BA'	BB	C	CA	D	DA	DB ¹⁾	E	EA	F	FA
		b	n	f	g	g1	a	m	m1	e	w1	w2	d	d1		l	l1	u	u1
IE1-K10R 280 S2 FAN	FF 600	457	88	522	550	416	368	94	-	431	190	188	70	70	M20	140	140	20	20
IE1-K10R 280 S4, 6, 8 FAN	FF 600	457	88	522	550	416	368	94	-	431	190	188	80	70	M20	170	140	22	20
IE1-K10R 280 M2 FAN	FF 600	457	88	522	550	416	419	94	-	482	190	192	70	70	M20	140	140	20	20
IE1-K10R 280 M4, 6, 8 FAN	FF 600	457	88	522	550	416	419	94	-	482	190	192	80	70	M20	170	140	22	20
IE1-K10R 315 S2 FAN	FF 600	508	132	590	550	416	406	120	150	554	216	259	75	70	M20	140	140	20	20
IE1-K10R 315 S4 FAN	FF 600	508	132	590	550	416	406	120	150	554	216	259	90	70	M24	170	140	25	20
IE1-K10R 315 S6, 8 FAN	FF 600	508	132	590	550	416	406	120	150	554	216	179	90	70	M24	170	140	25	20
IE1-K10R 315 M2 FAN	FF 600	508	110	590	610	494	457	120	-	573	216	307	75	75	M20	140	140	20	20
IE1-K10R 315 M4, 6, 8 FAN	FF 600	508	110	590	610	494	457	120	-	573	216	307	90	75	M24	170	140	25	20
IE1-K10R 315 M10, 12 FAN	FF 600	508	132	590	550	494	457	120	150	554	216	307	90	75	M24	170	140	25	20
IE1-K10R 315 L2 FAN	FF 600	508	110	590	610	494	508	120	-	624	216	376	75	75	M20	140	140	20	20
IE1-K10R 315 L4, 6, 8 FAN	FF 600	508	110	590	610	494	508	120	-	624	216	376	90	75	M24	170	140	25	20
IE1-K10R 315 LX2 FAN	FF 600	508	110	590	610	494	508	120	-	624	216	496	75	75	M20	140	140	20	20
IE1-K10R 315 LX4 FAN	FF 600	508	110	590	610	494	508	120	-	624	216	496	90	75	M24	170	140	25	20
IE1-K10R 315 LX6, 8 FAN	FF 600	508	110	590	610	494	508	120	-	624	216	376	90	75	M24	170	140	25	20

¹⁾ Centre holes to DIN 332-DS

Three-phase motors with squirrel-cage rotor for use in powered smoke and heat extraction systems to EN 12101-3
Energy-saving motor, efficiency class Standard Efficiency IE1

Surface cooling, type of cooling IC 418, degree of protection IP 55
 Size 280, 315

Type of construction IM B35 [IM 2001]

Flange dimensions, see page 8/23

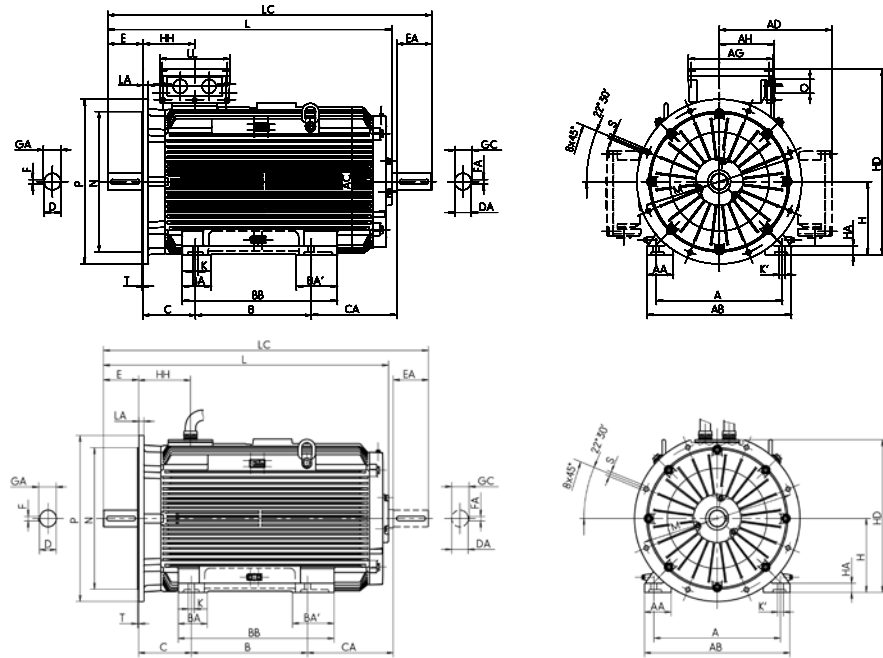

Type designation	GA	GC	H	HA	HD	HD ^{*)}	HD	HD ^{*)}	HH	K	K'	L	LC	TB Type	AG	LL	AH	O
	t	t1	h	c	p	p	p	p	A	s	s'	k	k1		x	z	-	r
IE1-K10R 280 S2 FAN	74.5	74.5	280	40	696	560	595	560	211	24	30	879	1026	200 A	282	242	-	M63 x 1.5
IE1-K10R 280 S4, 6, 8 FAN	85	74.5	280	40	696	560	595	560	211	24	30	909	1056	200 A	282	242	-	M63 x 1.5
IE1-K10R 280 M2 FAN	74.5	74.5	280	40	696	560	595	560	211	24	30	934	1081	200 A	282	242	-	M63 x 1.5
IE1-K10R 280 M4, 6, 8 FAN	85	74.5	280	40	696	560	595	560	211	24	30	964	1111	200 A	282	242	-	M63 x 1.5
IE1-K10R 315 S2 FAN	79.5	74.5	315	44	731	595	630	595	211	28	35	1014	1161	200 A	282	242	-	M63 x 1.5
IE1-K10R 315 S4 FAN	95	74.5	315	44	731	595	630	595	211	28	35	1044	1191	200 A	282	242	-	M63 x 1.5
IE1-K10R 315 S6, 8 FAN	95	74.5	315	44	731	595	630	595	211	28	35	964	1111	200 A	282	242	-	M63 x 1.5
IE1-K10R 315 M2 FAN	79.5	79.5	315	44	809	628	663	628	230	28	35	1116	1260	400 B	315	294	265	M63 x 1.5
IE1-K10R 315 M4, 6, 8 FAN	95	79.5	315	44	809	628	663	628	230	28	35	1146	1290	400 B	315	294	265	M63 x 1.5
IE1-K10R 315 M10, 12 FAN	95	79.5	315	44	774	595	630	595	211	28	35	1146	1290	400 B	315	294	265	M63 x 1.5
IE1-K10R 315 L2 FAN	79.5	79.5	315	44	809	628	663	628	230	28	35	1236	1380	400 B	315	294	265	M63 x 1.5
IE1-K10R 315 L4, 6, 8 FAN	95	79.5	315	44	809	628	663	628	230	28	35	1266	1410	400 B	315	294	265	M63 x 1.5
IE1-K10R 315 LX2 FAN	79.5	79.5	315	44	809	628	663	628	230	28	35	1356	1500	400 B	315	294	265	M63 x 1.5
IE1-K10R 315 LX4 FAN	95	79.5	315	44	809	628	663	628	230	28	35	1386	1530	400 B	315	294	265	M63 x 1.5
IE1-K10R 315 LX6, 8 FAN	95	79.5	315	44	809	628	663	628	230	28	35	1266	1410	400 B	315	294	265	M63 x 1.5

**) Terminal box left/right

Three-phase motors with squirrel-cage rotor for use in powered smoke and heat extraction systems to EN 12101-3
Energy-saving motor, efficiency class Standard Efficiency IE1

Surface cooling, type of cooling IC 410, degree of protection IP 55
 Size 132 to 160

Type of construction IM B14 [IM 3601]

Flange dimensions, see page 8/23

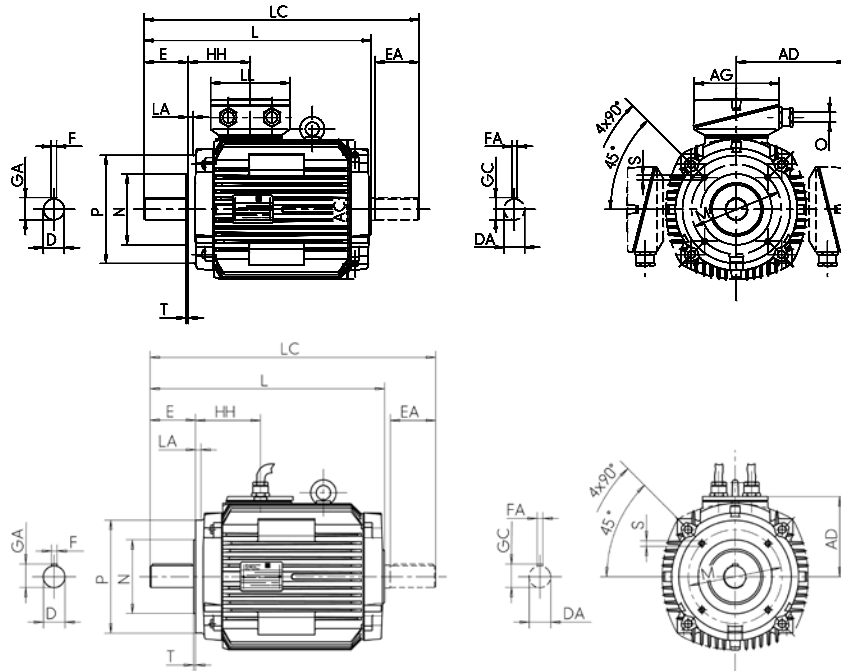

Type designation	Flange size		A	AA	AB	AC	AD	AD	B	BA	BB	C	CA	D	DA	DB ¹⁾	E	EA	F	FA
	small	large	b	n	f	g	g1	g1	a	m	e	w1	w2	d	d1		l	l1	u	u1
IE1-K10R 132 S FAN	FT 165	FT 215	216	50	256	258	199	144	140	52.5	180	89	117	38	38	M12	80	80	10	10
IE1-K10R 132 M FAN	FT 165	FT 215	216	50	256	258	199	144	178	52.5	218	89	127	38	38	M12	80	80	10	10
IE1-K10R 160 S2 FAN	FT 215	FT 265	254	55	296	313	242	172	178	56	225	108	119	42	42	M16	110	110	12	12
IE1-K10R 160 S4, 6, 8 FAN	FT 215	FT 265	254	55	296	313	242	172	178	56	225	108	119	48	42	M16	110	110	14	12
IE1-K10R 160 M2 FAN	FT 215	FT 265	254	55	296	313	242	172	210	56	257	108	125	42	42	M16	110	110	12	12
IE1-K10R 160 M4, 6, 8 FAN	FT 215	FT 265	254	55	296	313	242	172	210	56	257	108	125	48	42	M16	110	110	14	12

¹⁾ Centre holes to DIN 332-DS

Three-phase motors with squirrel-cage rotor for use in powered smoke and heat extraction systems to EN 12101-3
Energy-saving motor, efficiency class Standard Efficiency IE1

Surface cooling, type of cooling IC 410, degree of protection IP 55
 Size 132 to 160

Type of construction IM B34 [IM 2101]

Flange dimensions, see page 8/23

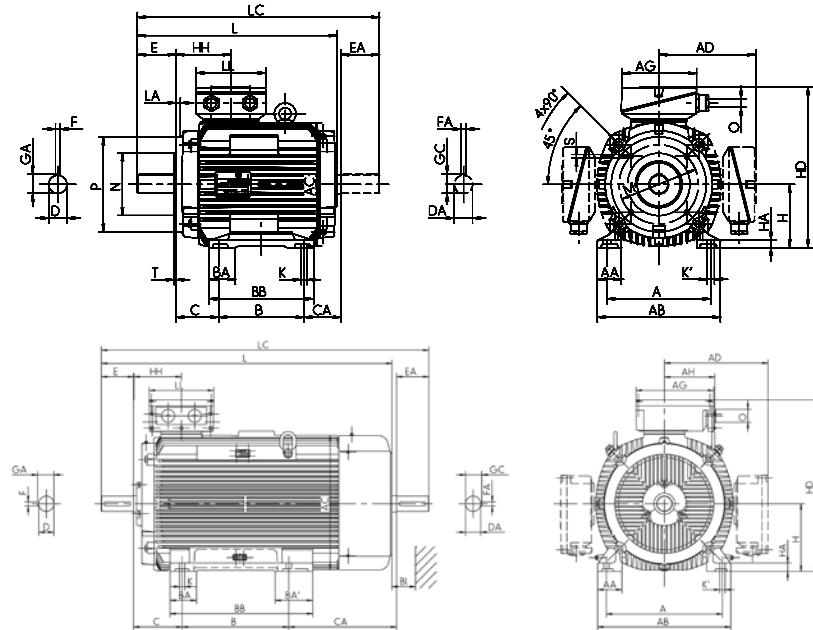

Type designation	GA	GC	H	HA	HD	HD ^{**} with TB	HD	HD ^{**} Cable	HH	K	K'	L	LC	TB Type	AG	LL	O
	t	t1	h	c	p	p	p	p	A	s	s'	k	k1				
IE1-K10R 132 S FAN	41	41	132	15	331	279	276	279	114	12	12	420	506	25 A	156	145	M32 x 1.5
IE1-K10R 132 M FAN	41	41	132	15	331	279	276	279	114	12	12	468	554	25 A	156	145	M32 x 1.5
IE1-K10R 160 S2 FAN	45	45	160	18	402	336	332	336	138	15	20	502	625	63 A	193	167	M40 x 1.5
IE1-K10R 160 S4, 6, 8 FAN	51.5	45	160	18	402	336	332	336	138	15	20	502	625	63 A	193	167	M40 x 1.5
IE1-K10R 160 M2 FAN	45	45	160	18	402	336	332	336	138	15	20	540	663	63 A	193	167	M40 x 1.5
IE1-K10R 160 M4, 6, 8 FAN	51.5	45	160	18	402	336	332	336	138	15	20	540	663	63 A	193	167	M40 x 1.5

**) Terminal box left/right

Three-phase motors with squirrel-cage rotor for use in powered smoke and heat extraction systems to EN 12101-3
Energy-saving motor, efficiency class Standard Efficiency IE1

Surface cooling, type of cooling IC 410, degree of protection IP 55
 Size 56 to 250

Type of construction IM B5 [IM 3001]
Type of construction IM V1 [IM 3011]

Flange dimensions, see page 8/23

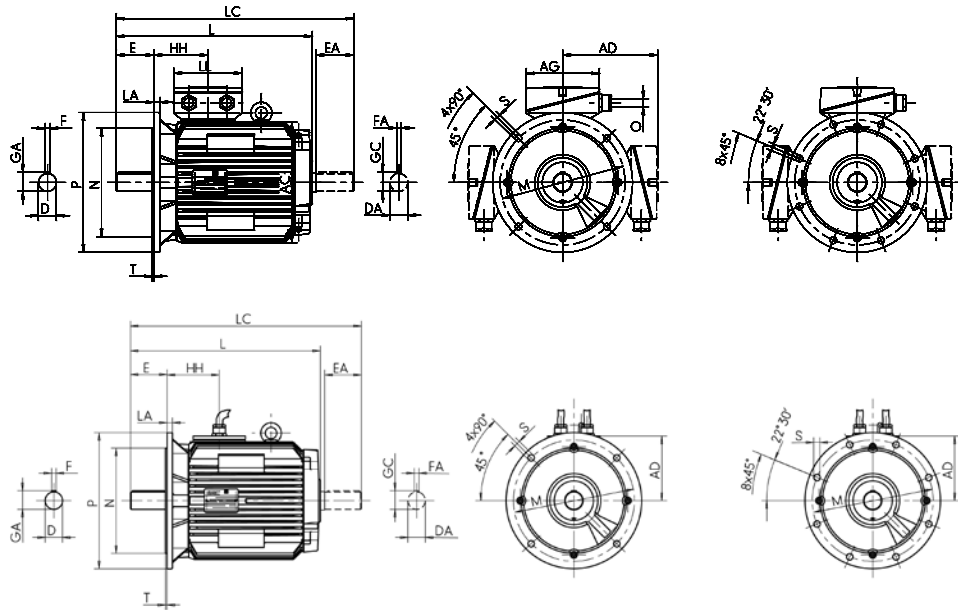

Type designation	Flange size	AC	AD	AD	D	DA	DB ¹⁾	E	EA	F	FA	GA	GC	H	HH	L	LC	TB	Type	AG	LL	O	Hole
		g	g1	g1	d	d1		l	l1	u	u1	t	t1	h	A	k	k1						pattern
IE1-K10R 132 S FAN	FF 300	258	199	144	38	38	M12	80	80	10	10	41	41	132	114	420	506	25 A	156	145	M32 x 1.5	4L	
IE1-K10R 132 M FAN	FF 300	258	199	144	38	38	M12	80	80	10	10	41	41	132	114	468	554	25 A	156	145	M32 x 1.5	4L	
IE1-K10R 160 S2 FAN	FF 300	313	242	172	42	42	M16	110	110	12	12	45	45	160	138	502	625	63 A	193	167	M40 x 1.5	4L	
IE1-K10R 160 S4, 6, 8 FAN	FF 300	313	242	172	48	42	M16	110	110	14	12	51.5	45	160	138	502	625	63 A	193	167	M40 x 1.5	4L	
IE1-K10R 160 M2 FAN	FF 300	313	242	172	42	42	M16	110	110	12	12	45	45	160	138	540	663	63 A	193	167	M40 x 1.5	4L	
IE1-K10R 160 M4, 6, 8 FAN	FF 300	313	242	172	48	42	M16	110	110	14	12	51.5	45	160	138	540	663	63 A	193	167	M40 x 1.5	4L	
IE1-K10R 180 S2 FAN	FF 350	351	261	191	48	48	M16	110	110	14	14	51.5	51.5	180	147	562	689	63 A	193	167	M40 x 1.5	4L	
IE1-K10R 180 S4, 6, 8 FAN	FF 350	351	261	191	55	48	M20	110	110	16	14	59	51.5	180	147	562	689	63 A	193	167	M40 x 1.5	4L	
IE1-K10R 180 M2 FAN	FF 350	351	261	191	48	48	M16	110	110	14	14	51.5	51.5	180	147	607	734	63 A	193	167	M40 x 1.5	4L	
IE1-K10R 180 M4, 6, 8 FAN	FF 350	351	261	191	55	48	M20	110	110	16	14	59	51.5	180	147	607	734	63 A	193	167	M40 x 1.5	4L	
IE1-K10R 200 M2 FAN	FF 400	390	300	211	55	55	M20	110	110	16	16	59	59	200	168	661	797	100 A	213	207	M50 x 1.5	4L	
IE1-K10R 200 M4, 6, 8 FAN	FF 400	390	300	211	60	55	M20	140	110	18	16	64	59	200	168	691	827	100 A	213	207	M50 x 1.5	4L	
IE1-K10R 200 L2 FAN	FF 400	390	300	211	55	55	M20	110	110	16	16	59	59	200	168	701	837	100 A	213	207	M50 x 1.5	4L	
IE1-K10R 200 L4, 6, 8 FAN	FF 400	390	300	211	60	55	M20	140	110	18	16	64	59	200	168	731	867	100 A	213	207	M50 x 1.5	4L	
IE1-K10R 225 M2 FAN	FF 500	440	324	235	55	55	M20	110	110	16	16	59	59	225	177	707	827	100 A	213	207	M50 x 1.5	8L	
IE1-K10R 225 M4, 6, 8 FAN	FF 500	440	324	235	65	55	M20	140	110	18	16	69	59	225	177	737	857	100 A	213	207	M50 x 1.5	8L	
IE1-K10R 250 S2 FAN	FF 500	490	386	263	65	65	M20	140	140	18	18	69	69	250	206	801	951	200 A	213	207	M63 x 1.5	8L	
IE1-K10R 250 S4, 6, 8 FAN	FF 500	490	386	263	75	65	M20	140	140	20	18	79.5	69	250	206	801	951	200 A	213	207	M63 x 1.5	8L	
IE1-K10R 250 M2 FAN	FF 500	490	386	263	65	65	M20	140	140	18	18	69	69	250	206	801	951	200 A	213	207	M63 x 1.5	8L	
IE1-K10R 250 M4 FAN	FF 500	490	386	263	75	65	M20	140	140	20	18	79.5	69	250	206	847	997	200 A	213	207	M63 x 1.5	8L	
IE1-K10R 250 M6, 8 FAN	FF 500	490	386	263	65	65	M20	140	140	18	18	69	69	250	206	801	951	200 A	213	207	M63 x 1.5	8L	

¹⁾ Centre holes to DIN 332-DS

Three-phase motors with squirrel-cage rotor for use in powered smoke and heat extraction systems to EN 12101-3
Energy-saving motor, efficiency class Standard Efficiency IE1

Surface cooling, type of cooling IC 410, degree of protection IP 55
 Size 280, 315

Type of construction IM B5 [IM 3001]
Type of construction IM V1 [IM 3011]

Flange dimensions, see page 8/23

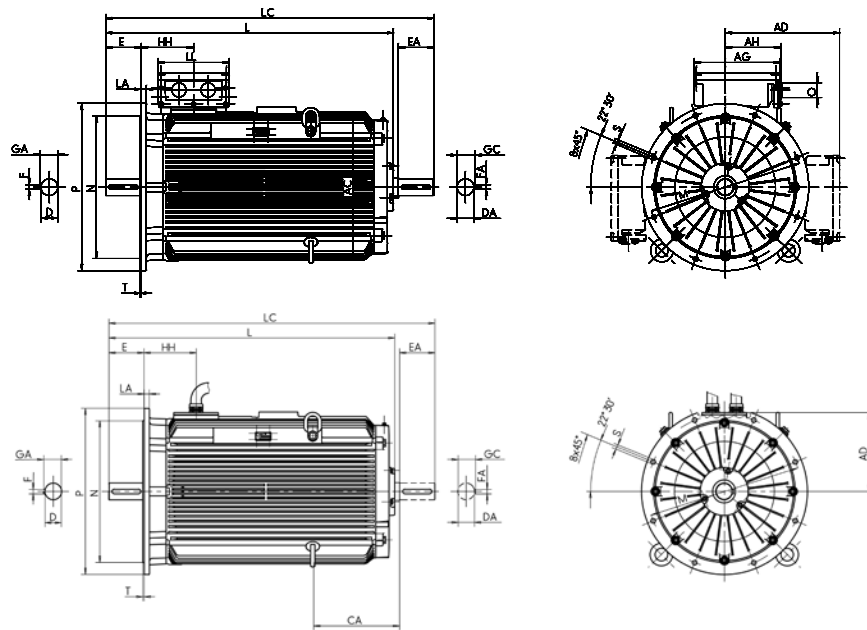

Type designation	Flange size	AC	AD	AD	D	DA	DB ¹⁾	E	EA	F	FA	GA	GC	H	HH	L	LC	TB	Type	AG	LL	AH	O
		g	g1	g1	d	d1		l	l1	u	u1	t	t1	h	A	k	k1		x	z	-	r	
IE1-K10R 280 S2 FAN	FF 600	550	416	315	70	70	M20	140	140	20	20	74.5	74.5	280	211	879	1026	200	A	282	242	-	M63 x 1.5
IE1-K10R 280 S4. 6. 8 FAN	FF 600	550	416	315	80	70	M20	170	140	22	20	85	74.5	280	211	909	1056	200	A	282	242	-	M63 x 1.5
IE1-K10R 280 M2 FAN	FF 600	550	416	315	70	70	M20	140	140	20	20	74.5	74.5	280	211	934	1081	200	A	282	242	-	M63 x 1.5
IE1-K10R 280 M4. 6. 8 FAN	FF 600	550	416	315	80	70	M20	170	140	22	20	85	74.5	280	211	964	1111	200	A	282	242	-	M63 x 1.5
IE1-K10R 315 S2 FAN	FF 600	550	416	315	75	70	M20	140	140	20	20	79.5	74.5	315	211	1014	1161	200	A	282	242	-	M63 x 1.5
IE1-K10R 315 S4 FAN	FF 600	550	416	315	90	70	M24	170	140	25	20	95	74.5	315	211	1044	1191	200	A	282	242	-	M63 x 1.5
IE1-K10R 315 S6. 8 FAN	FF 600	550	416	315	90	70	M24	170	140	25	20	95	74.5	315	211	964	1111	200	A	282	242	-	M63 x 1.5
IE1-K10R 315 M2 FAN	FF 600	610	494	348	75	75	M20	140	140	20	20	79.5	79.5	315	230	1116	1260	400	A	315	294	265	M63 x 1.5
IE1-K10R 315 M4. 6. 8 FAN	FF 600	610	494	348	90	75	M24	170	140	25	20	95	79.5	315	230	1146	1290	400	B	315	294	265	M63 x 1.5
IE1-K10R 315 M10. 12 FAN	FF 600	550	494	315	90	75	M24	170	140	25	20	95	79.5	315	211	1146	1290	400	B	315	294	265	M63 x 1.5
IE1-K10R 315 L2 FAN	FF 600	610	494	348	75	75	M20	140	140	20	20	79.5	79.5	315	230	1236	1380	400	B	315	294	265	M63 x 1.5
IE1-K10R 315 L4. 6. 8 FAN	FF 600	610	494	348	90	75	M24	170	140	25	20	95	79.5	315	230	1266	1410	400	B	315	294	265	M63 x 1.5
IE1-K10R 315 LX2 FAN	FF 600	610	494	348	75	75	M20	140	140	20	20	79.5	79.5	315	230	1356	1500	400	B	315	294	265	M63 x 1.5
IE1-K10R 315 LX4 FAN	FF 600	610	494	348	90	75	M24	170	140	25	20	95	79.5	315	230	1386	1530	400	B	315	294	265	M63 x 1.5
IE1-K10R 315 LX6. 8 FAN	FF 600	610	494	348	90	75	M24	170	140	25	20	95	79.5	315	230	1266	1410	400	B	315	294	265	M63 x 1.5

¹⁾ Centre holes to DIN 332-DS

Three-phase motors with squirrel-cage rotor for use in powered smoke and heat extraction systems to EN 12101-3
Energy-saving motor, efficiency class Standard Efficiency IE1

Surface cooling, type of cooling IC 411, degree of protection IP 55
 Size 132 to 280

Type of construction IM B3 [IM 1001]

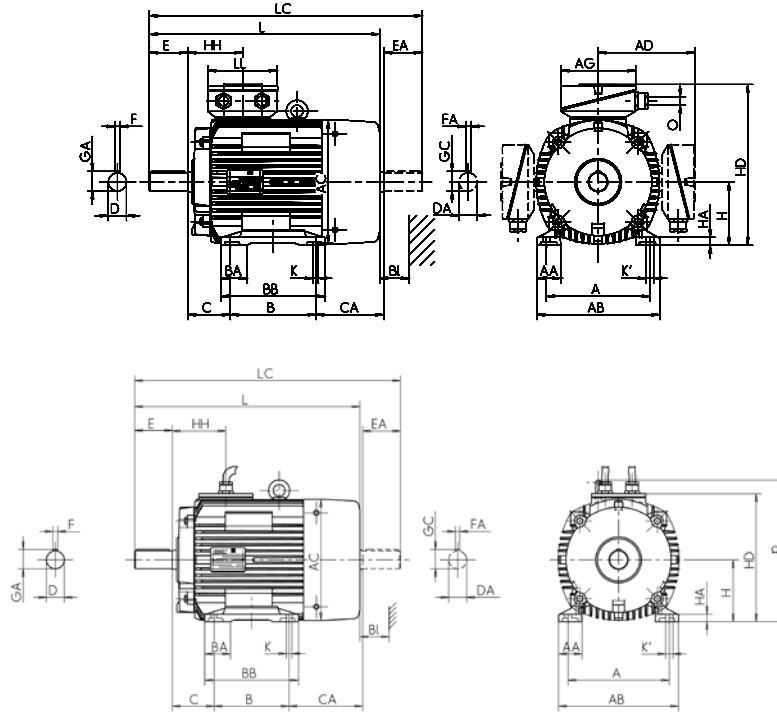

Type designation	Flange size	A	AA	AB	AC	AD	AD	B	BA	BB	C	CA	D	DA	DB ¹⁾	E	EA	F	FA
		b	n	f	g	g1	g1	a	m	e	w1	w2	d	d1	l	l1	u	u1	
(IE1-)K21R 132 M4	FF265	216	50	256	258	199	144	178	53	218	89	138	38	38	M12	80	80	10	10
(IE1-)K21R 132 MX6	FF265	216	50	256	258	199	144	178	53	218	89	138	38	38	M12	80	80	10	10
(IE1-)K21R 160 M2	FF300	254	55	296	258	214	144	210	60	257	108	135	42	38	M16	110	80	12	10
(IE1-)K21R 160 M4, 6, 8	FF300	254	55	296	258	214	144	210	60	257	108	135	42	38	M16	110	80	12	10
(IE1-)K21R 160 MX8	FF300	254	55	296	258	214	144	210	60	257	108	135	42	38	M16	110	80	12	10
(IE1-)K21R 160 MX2	FF300	254	55	296	313	242	172	210	60	257	108	148	42	42	M16	110	110	12	12
(IE1-)K21R 160 L2, 4, 6, 8	FF300	254	55	296	313	242	172	254	60	301	108	142	42	42	M16	110	110	12	12
(IE1-)K21R 180 M2	FF300	279	62	328	351	261	191	241	65	288	121	169	48	48	M16	110	110	14	14
(IE1-)K21R 180 M4	FF300	279	62	328	313	242	172	241	65	288	121	142	48	42	M16	110	110	14	12
(IE1-)K21R 180 L4	FF300	279	62	328	351	261	191	279	65	326	121	176	48	48	M16	110	110	14	14
(IE1-)K21R 180 L6, 8	FF300	279	62	328	313	242	172	279	65	326	121	104	48	42	M16	110	110	14	12
(IE1-)K21R 200 L2, 4, 6, 8	FF 350	318	70	372	351	261	191	305	70	360	133	138	55	48	M20	110	110	16	14
(IE1-)K21R 200 LX6	FF 350	318	70	372	351	261	191	305	70	360	133	138	55	48	M20	110	110	16	14
(IE1-)K21R 200 LX2	FF 350	318	70	372	390	300	211	305	70	360	133	193	55	55	M20	110	110	16	16
(IE1-)K21R 225 S4, 8	FF 400	356	75	413	390	300	211	286	75	343	149	196	60	55	M20	140	110	18	16
(IE1-)K21R 225 M2	FF 400	356	75	413	390	300	211	311	75	368	149	211	55	55	M20	110	110	16	16
(IE1-)K21R 225 M4	FF 400	356	75	413	390	300	211	311	75	368	149	211	60	55	M20	140	110	18	16
(IE1-)K21R 225 M6, 8	FF 400	356	75	413	390	300	211	311	75	368	149	171	60	55	M20	140	110	18	16
(IE1-)K21R 250 M2	FF 500	406	84	471	440	358	235	349	84	412	168	210	60	55	M20	140	110	18	16
(IE1-)K21R 250 M4, 6, 8	FF 500	406	84	471	440	358	235	349	84	412	168	210	65	55	M20	140	110	18	16
(IE1-)K21R 280 S2	FF 500	457	94	522	490	386	285	368	96	431	190	234	65	65	M20	140	140	18	18
(IE1-)K21R 280 S4, 6, 8	FF 500	457	94	522	490	386	285	368	96	431	190	234	75	65	M20	140	140	20	18
(IE1-)K21R 280 M2	FF 500	457	94	522	490	386	285	419	96	482	190	229	65	65	M20	140	140	18	18
(IE1-)K21R 280 M4, 6, 8	FF 500	457	94	522	490	386	285	419	96	482	190	229	75	65	M20	140	140	20	18

¹⁾ Centre holes to DIN 332-DS

Three-phase motors with squirrel-cage rotor for use in powered smoke and heat extraction systems to EN 12101-3
Energy-saving motor, efficiency class Standard Efficiency IE1

Surface cooling, type of cooling IC 411, degree of protection IP 55
 Size 132 to 280

Type of construction IM B35 [IM 2001]

Flange dimensions, see page 8/23

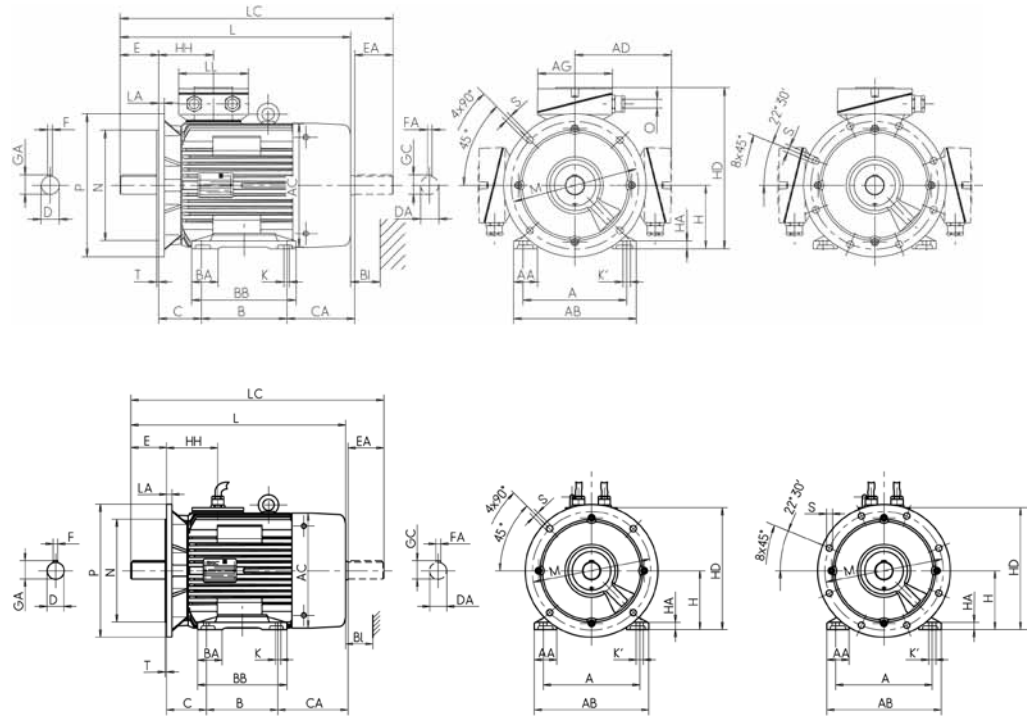

Type designation	GA	GC	H	HA	HD	HD ^{*)}	HD	HH	K	K'	L	LC	TB Type	AG	LL	O	Hole	BI
	t	t1	h	c	p	p	p	A	s	s'	k	k1	X	Z	pattern			BI
(IE1-)K21R 132 M4	41	41	132	16	331	279	276	114	12	12	481	565	25 A	156	145	M32 x 1.5	4L	35
(IE1-)K21R 132 MX6	41	41	132	16	331	279	276	114	12	12	481	565	25 A	156	145	M32 x 1.5	4L	35
(IE1-)K21R 160 M2	45	41	160	18	363	307	304	114	15	15	559	643	25 A	156	145	M32 x 1.5	4L	35
(IE1-)K21R 160 M4, 6, 8	45	41	160	18	363	307	304	114	15	15	559	643	25 A	156	145	M32 x 1.5	4L	35
(IE1-)K21R 160 MX8	45	41	160	18	363	307	304	114	15	15	559	643	25 A	156	145	M32 x 1.5	4L	35
(IE1-)K21R 160 MX2	45	45	160	18	409	336	332	138	15	20	571	686	63 A	193	167	M40 x 1.5	4L	35
(IE1-)K21R 160 L2, 4, 6, 8	45	45	160	18	409	336	332	138	15	20	609	724	63 A	193	167	M40 x 1.5	4L	35
(IE1-)K21R 180 M2	51.5	51.5	180	20	441	369	371	147	15	20	635	751	63 A	193	167	M40 x 1.5	4L	35
(IE1-)K21R 180 M4	51.5	45	180	20	422	356	352	138	15	20	609	724	63 A	193	167	M40 x 1.5	4L	35
(IE1-)K21R 180 L4	51.5	51.5	180	20	441	369	371	147	15	20	680	796	63 A	193	167	M40 x 1.5	4L	35
(IE1-)K21R 180 L6, 8	51.5	45	180	20	422	369	352	138	15	20	609	724	63 A	193	167	M40 x 1.5	4L	35
(IE1-)K21R 200 L2, 4, 6, 8	59	51.5	200	22	461	389	391	147	19	25	680	796	63 A	193	167	M40 x 1.5	4L	35
(IE1-)K21R 200 LX6	59	51.5	200	22	461	389	391	147	19	25	680	796	63 A	193	167	M40 x 1.5	4L	35
(IE1-)K21R 200 LX2	59	59	200	22	500	417	411	168	19	25	727	851	100 A	213	207	M50 x 1.5	4L	35
(IE1-)K21R 225 S4, 8	64	59	225	25	527	442	436	168	19	25	757	881	100 A	213	207	M50 x 1.5	8L	40
(IE1-)K21R 225 M2	59	59	225	25	527	442	436	168	19	25	767	891	100 A	213	207	M50 x 1.5	8L	40
(IE1-)K21R 225 M4	64	59	225	25	527	442	436	168	19	25	797	921	100 A	213	207	M50 x 1.5	8L	40
(IE1-)K21R 225 M6, 8	64	59	225	25	527	442	436	168	19	25	757	881	100 A	213	207	M50 x 1.5	8L	40
(IE1-)K21R 250 M2	64	59	250	28	608	484	485	177	24	30	862	977	200 A	282	242	M63 x 1.5	8L	45
(IE1-)K21R 250 M4, 6, 8	69	59	250	28	608	484	485	177	24	30	862	977	200 A	282	242	M63 x 1.5	8L	45
(IE1-)K21R 280 S2	69	69	280	32	666	523	565	206	24	30	924	1072	200 A	282	242	M63 x 1.5	8L	50
(IE1-)K21R 280 S4, 6, 8	79.5	69	280	32	666	523	565	206	24	30	924	1072	200 A	282	242	M63 x 1.5	8L	50
(IE1-)K21R 280 M2	69	69	280	32	666	523	565	206	24	30	970	1118	200 A	282	242	M63 x 1.5	8L	50
(IE1-)K21R 280 M4, 6, 8	79.5	69	280	32	666	523	565	206	24	30	970	1118	200 A	282	242	M63 x 1.5	8L	50

**) Terminal box left/right

**Three-phase motors with squirrel-cage rotor for use in powered smoke and heat extraction systems to EN 12101-3
Energy-saving motor, efficiency class Standard Efficiency IE1**

Surface cooling, type of cooling IC 411, degree of protection IP 55
Size 315

Type of construction IM B3 [IM 1001]

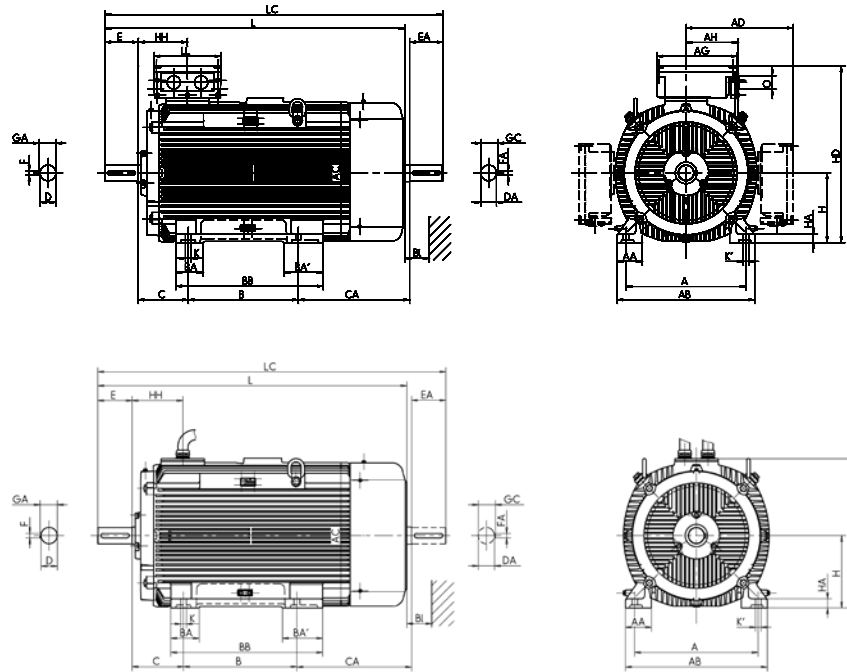

Type designation	Flange size	A	AA	AB	AC	AD	AD	B	BA	BA'	BB	C	CA	D	DA	DB ¹⁾	E	EA	F	FA
		b	n	f	g	g1	g1	a	m	m1	e	w1	w2	d	d1		l	l1	u	u1
(IE1-)K21R 315 S2	FF 600	508	126	590	550	416	315	406	120	-	503	216	316	65	65	M20	140	140	18	18
(IE1-)K21R 315 S4, 6, 8	FF 600	508	126	590	550	416	315	406	120	-	503	216	316	80	70	M20	170	140	22	20
(IE1-)K21R 315 M2	FF 600	508	126	590	550	416	315	457	120	-	554	216	320	65	65	M20	140	140	18	18
(IE1-)K21R 315 M4, 6, 8	FF 600	508	126	590	550	416	315	457	120	-	554	216	320	80	70	M20	170	140	22	20
(IE1-)K21R 315 MX2	FF 600	508	126	590	550	416	315	457	120	150	554	216	400	65	65	M20	140	140	18	18
(IE1-)K21R 315 MX4	FF 600	508	126	590	550	416	315	457	120	150	554	216	400	80	70	M20	170	140	22	20
(IE1-)K21R 315 MX6, 8	FF 600	508	126	590	550	416	315	457	120	150	554	216	320	80	70	M20	170	140	22	20
(IE1-)K21R 315 MX10, 12	FF 600	508	126	590	550	416	315	457	120	150	554	216	320	80	70	M20	170	140	22	20
(IE1-)K21R 315 MY2	FF 600	508	110	590	610	494	348	457	120	-	573	216	495	65	65	M20	140	140	18	18
(IE1-)K21R 315 MY4, 6, 8	FF 600	508	110	590	610	494	348	457	120	-	573	216	495	80	70	M20	170	140	22	20
(IE1-)K21R 315 L2	FF 600	508	110	590	610	494	348	508	120	-	624	216	539	65	65	M20	140	140	18	18
(IE1-)K21R 315 L4, 6, 8	FF 600	508	110	590	610	494	348	508	120	-	624	216	564	80	70	M20	170	140	22	20
(IE1-)K21R 315 LX2	FF 600	508	110	590	610	494	348	508	120	-	624	216	684	65	65	M20	140	140	18	18
(IE1-)K21R 315 LX4	FF 600	508	110	590	610	494	348	508	120	-	624	216	689	80	70	M20	170	140	22	20
(IE1-)K21R 315 LX6, 8	FF 600	508	110	590	610	494	348	508	120	-	624	216	564	80	70	M20	170	140	22	20

¹⁾ Centre holes to DIN 332-DS

Three-phase motors with squirrel-cage rotor for use in powered smoke and heat extraction systems to EN 12101-3
Energy-saving motor, efficiency class Standard Efficiency IE1

Surface cooling, type of cooling IC 411, degree of protection IP 55
 Size 315

Type of construction IM B35 [IM 2001]

Flange dimensions, see page 8/23

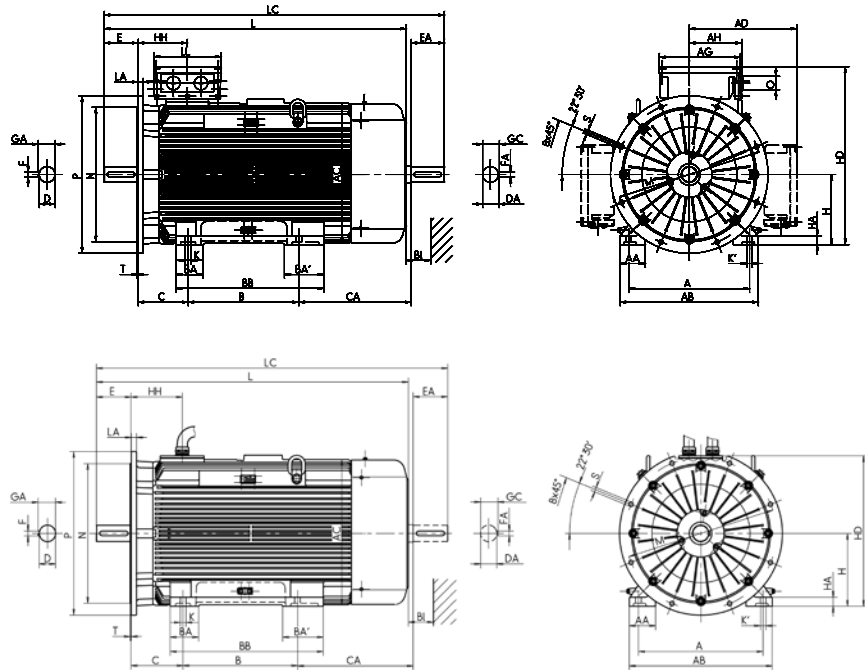

Type designation	GA	GC	H	HA	HD	HD ^{*)}	HD	HH	K	K'	L	LC	TB Type	AG	LL	AH	O	BI
	t	t1	h	c	p	p	p	A	s	s'	k	k1		x	z	-	r	BI
(IE1-)K21R 315 S2	69	69	315	44	731	595	630	211	28	35	1050	1218	200 A	282	242	-	M63 x 1.5	55
(IE1-)K21R 315 S4, 6, 8	85	74.5	315	44	731	595	630	211	28	35	1080	1248	200 A	282	242	-	M63 x 1.5	55
(IE1-)K21R 315 M2	69	69	315	44	731	595	630	211	28	35	1105	1273	200 A	282	242	-	M63 x 1.5	55
(IE1-)K21R 315 M4, 6, 8	85	74.5	315	44	731	595	630	211	28	35	1135	1303	200 A	282	242	-	M63 x 1.5	55
(IE1-)K21R 315 MX2	69	69	315	44	731	595	630	211	28	35	1185	1353	200 A	282	242	-	M63 x 1.5	55
(IE1-)K21R 315 MX4	85	74.5	315	44	731	595	630	211	28	35	1210	1383	200 A	282	242	-	M63 x 1.5	55
(IE1-)K21R 315 MX6, 8	85	74.5	315	44	731	595	630	211	28	35	1135	1303	200 A	282	242	-	M63 x 1.5	55
(IE1-)K21R 315 MX10, 12	85	74.5	315	44	731	595	630	211	28	35	1135	1303	200 A	282	242	-	M63 x 1.5	55
(IE1-)K21R 315 MY2	69	69	315	44	809	628	663	230	28	35	1270	1448	400 B	415	340	265	M63 x 1.5	55
(IE1-)K21R 315 MY4, 6, 8	85	74.5	315	44	809	628	663	230	28	35	1300	1478	400 B	415	340	265	M63 x 1.5	55
(IE1-)K21R 315 L2	69	69	315	44	809	628	663	230	28	35	1390	1543	400 B	415	340	265	M63 x 1.5	55
(IE1-)K21R 315 L4, 6, 8	85	74.5	315	44	809	628	663	230	28	35	1420	1598	400 B	415	340	265	M63 x 1.5	55
(IE1-)K21R 315 LX2	69	69	315	44	809	628	663	230	28	35	1510	1688	400 B	415	340	265	M63 x 1.5	55
(IE1-)K21R 315 LX4	85	74.5	315	44	809	628	663	230	28	35	1540	1723	400 B	415	340	265	M63 x 1.5	55
(IE1-)K21R 315 LX6, 8	85	74.5	315	44	809	628	663	230	28	35	1420	1598	400 B	415	340	265	M63 x 1.5	55

^{*)} Terminal box left/right

**Three-phase motors with squirrel-cage rotor for use in powered smoke and heat extraction systems to EN 12101-3
Energy-saving motor, efficiency class Standard Efficiency IE1**

Surface cooling, type of cooling IC 411, degree of protection IP 55
Size 355

Type of construction IM B3 [IM 1001]

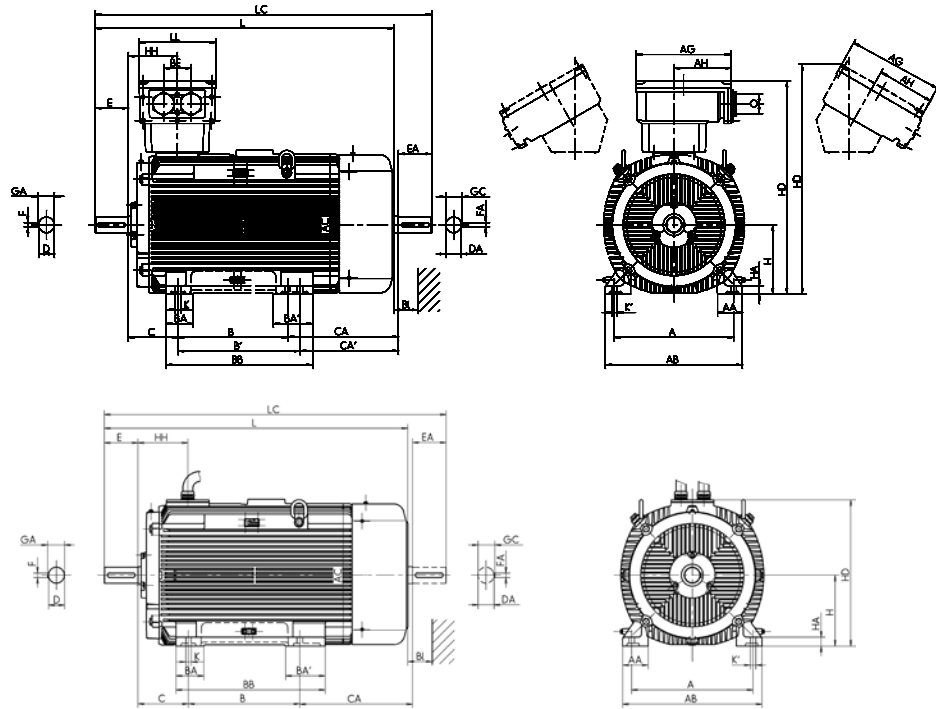

Type designation	Flange size	A	AA	AB	AC	B	BA	BA'	BB	C	CA	D	DA	DB ¹⁾	E	EA	F	FA
		b	n	f	g	a	m	m1	e	w1	w2	d	d1		l	l1	u	u1
(IE1-)K22R 355 MY2, M2	FF 740	610	130	700	715	560	140	200	750	254	561	80	80	M20	170	170	22	22
(IE1-)K22R 355 MY4, 6, 8	FF 740	610	130	700	715	560	140	200	750	254	561	100	80	M24	210	170	28	22
(IE1-)K22R 355 M4	FF 740	610	130	700	715	560	140	200	750	254	561	100	80	M24	210	170	28	22
(IE1-)K22R 355 M6, 8	FF 740	610	130	700	715	560	140	200	750	254	561	100	80	M24	210	170	28	22
(IE1-)K22R 355 MX6, 8	FF 740	610	130	700	715	560	140	200	750	254	681	100	80	M24	210	170	28	22
(IE1-)K22R 355 MX2	FF 740	610	130	700	715	560	140	200	750	254	681	80	80	M20	170	170	22	22
(IE1-)K22R 355 LY2, L2	FF 740	610	130	700	715	630	140	200	750	254	611	80	80	M20	170	170	22	22
(IE1-)K22R 355 MX4	FF 740	610	130	700	715	560	140	200	750	254	681	100	80	M24	210	170	28	22
(IE1-)K22R 355 LY4, L4	FF 740	610	130	700	715	630	140	200	750	254	611	100	80	M24	210	170	28	22
(IE1-)K22R 355 LY6, 8	FF 740	610	130	700	715	630	140	200	750	254	611	100	80	M24	210	170	28	22

¹⁾ Centre holes to DIN 332-DS

Three-phase motors with squirrel-cage rotor for use in powered smoke and heat extraction systems to EN 12101-3
Energy-saving motor, efficiency class Standard Efficiency IE1

Surface cooling, type of cooling IC 411, degree of protection IP 55
 Size 355

Type of construction IM B35 [IM 1001]

Flange dimensions, see page 8/23

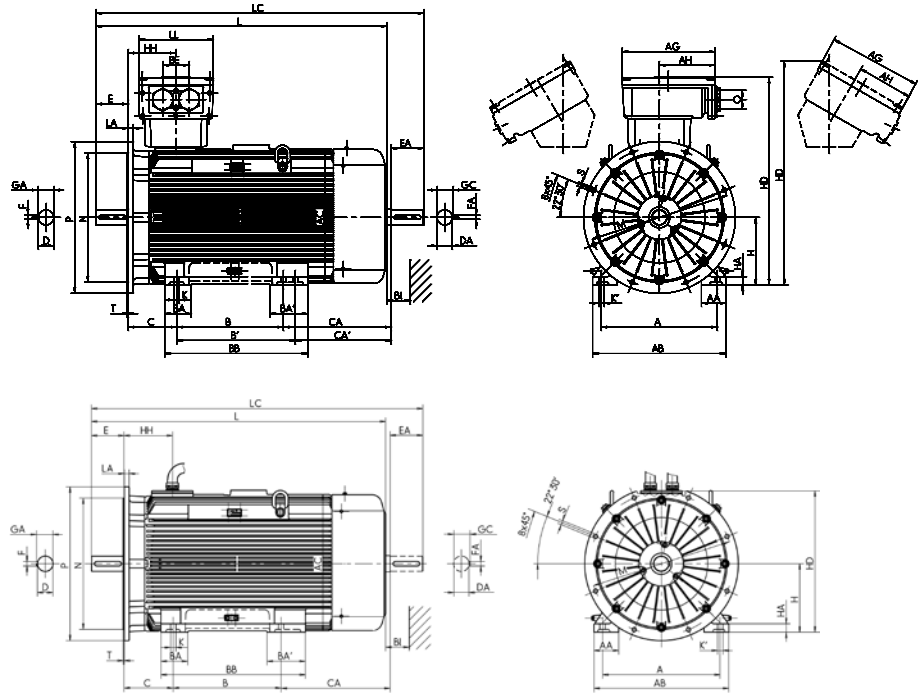

Type designation	GA	GC	H	HA	HD	HD ^{*)}	HD	HH	K	K'	L	LC	TB Type	AG	LL	AH	BE	O	BI
	t	t1	h	c	p	p	p	A	s	s'	k	k1		x	z	-	-	r	BI
(IE1-)K22R 355 MY2, M2	85	85	355	44	1091	1172	839	250	28	35	1530	1715	630 A	496	390	301	140	M72 x 2	60
(IE1-)K22R 355 MY4, 6, 8	106	85	355	44	1091	1172	839	250	28	35	1570	1755	630 A	496	390	301	140	M72 x 2	60
(IE1-)K22R 355 M4	106	85	355	44	1091	1172	839	250	28	35	1570	1755	630 A	496	390	301	140	M72 x 2	60
(IE1-)K22R 355 M6, 8	106	85	355	44	1091	1172	839	250	28	35	1570	1755	630 A	496	390	301	140	M72 x 2	60
(IE1-)K22R 355 MX6, 8	106	85	355	44	1091	1172	839	250	28	35	1690	1875	630 A	496	390	301	140	M72 x 2	60
(IE1-)K22R 355 MX2	85	85	355	44	1083	1174	839	327	28	35	1650	1835	1000 A	615	474	385	200	M72 x 2	60
(IE1-)K22R 355 LY2, L2	85	85	355	44	1083	1174	839	327	28	35	1650	1835	1000 A	615	474	385	200	M72 x 2	60
(IE1-)K22R 355 MX4	106	85	355	44	1083	1174	839	327	28	35	1690	1875	1000 A	615	474	385	200	M72 x 2	60
(IE1-)K22R 355 LY4, L4	106	85	355	44	1083	1174	839	327	28	35	1690	1875	1000 A	615	474	385	200	M72 x 2	60
(IE1-)K22R 355 LY6, 8	106	85	355	44	1083	1174	839	327	28	35	1690	1875	1000 A	615	474	385	200	M72 x 2	60

^{*)} Terminal box inclined left/right

Three-phase motors with squirrel-cage rotor for use in powered smoke and heat extraction systems to EN 12101-3
Energy-saving motor, efficiency class Standard Efficiency IE1

Surface cooling, type of cooling IC 411, degree of protection IP 55
 Size 132 to 180

Type of construction IM B14 [IM 3601]

Flange dimensions, see page 8/23

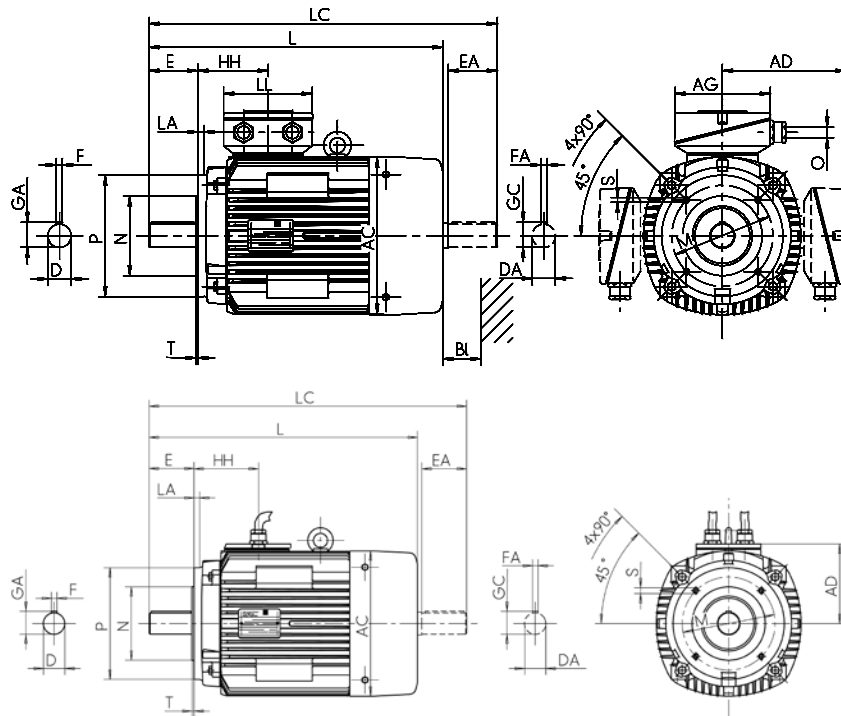

Type designation	Flange size		A	AA	AB	AC	AD	AD	B	BA	BB	C	CA	D	DA	DB ¹⁾	E	EA	F	FA
	small	large	b	n	f	g	g1	g1	a	m	e	w1	w2	d	d1		l	l1	u	u1
(IE1-)K21R 132 M4	FT 165	FT 215	216	50	256	258	199	144	178	53	218	89	138	38	38	M12	80	80	10	10
(IE1-)K21R 132 MX6	FT 165	FT 215	216	50	256	258	199	144	178	53	218	89	138	38	38	M12	80	80	10	10
(IE1-)K21R 160 M2	FT 165	FT 215	254	55	296	258	214	144	210	60	257	108	135	42	38	M16	110	80	12	10
(IE1-)K21R 160 M4, 6, 8	FT 165	FT 215	254	55	296	258	214	144	210	60	257	108	135	42	38	M16	110	80	12	10
(IE1-)K21R 160 MX8	FT 165	FT 215	254	55	296	258	214	144	210	60	257	108	135	42	38	M16	110	80	12	10
(IE1-)K21R 160 MX2	FT 215	FT 265	254	55	296	313	242	172	210	60	257	108	148	42	42	M16	110	110	12	12
(IE1-)K21R 160 L2, 4, 6, 8	FT 215	FT 265	254	55	296	313	242	172	254	60	301	108	142	42	42	M16	110	110	12	12
(IE1-)K21R 180 M4	FT 265	-	279	62	328	313	242	172	241	65	288	121	142	48	42	M16	110	110	14	12
(IE1-)K21R 180 L6, 8	FT 265	-	279	62	328	313	242	172	279	65	326	121	104	48	42	M16	110	110	14	12

¹⁾ Centre holes to DIN 332-DS

Three-phase motors with squirrel-cage rotor for use in powered smoke and heat extraction systems to EN 12101-3
Energy-saving motor, efficiency class Standard Efficiency IE1

Surface cooling, type of cooling IC 411, degree of protection IP 55
 Size 132 to 180

Type of construction IM B34 [IM 2101]

Flange dimensions, see page 8/23

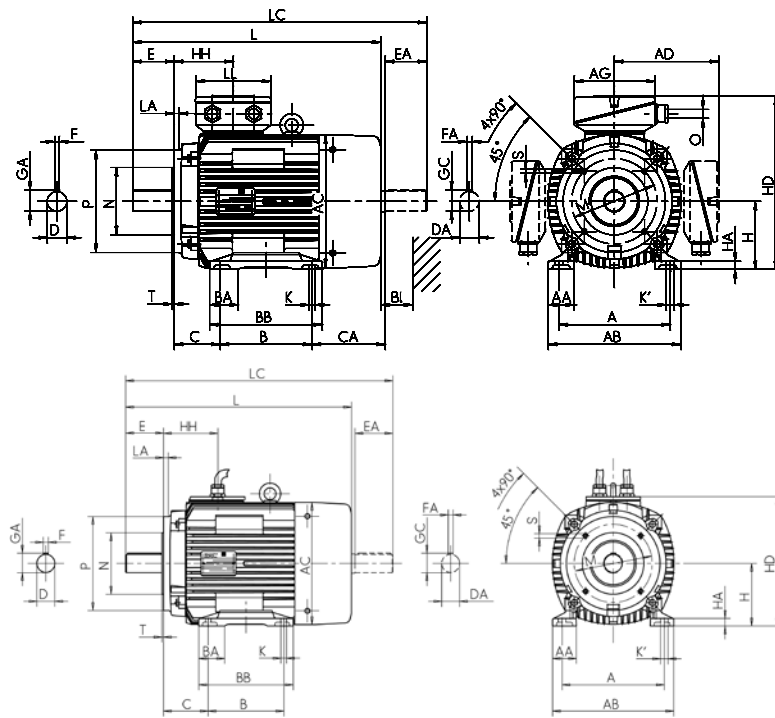

Type designation	GA	GC	H	HA	HD	HD ^{*)} with TB	HD Cable	HH	K	K'	L	LC	TB Type	AG	LL	O	Hole	BI
	t	t1	h	c	p	p	p	A	s	s'	k	k1	-	x	z	r	pattern	BI
(IE1-)K21R 132 M4	41	41	132	16	349	297	276	114	12	12	481	565	25 A	156	145	M32 x 1.5	4L	35
(IE1-)K21R 132 MX6	41	41	132	16	349	297	276	114	12	12	481	565	25 A	156	145	M32 x 1.5	4L	35
(IE1-)K21R 160 M2	45	41	160	18	389	322	304	114	15	15	559	643	25 A	193	167	M32 x 1.5	4L	35
(IE1-)K21R 160 M4, 6, 8	45	41	160	18	389	322	304	114	15	15	559	643	25 A	193	167	M32 x 1.5	4L	35
(IE1-)K21R 160 MX8	45	41	160	18	389	322	304	114	15	15	559	643	25 A	193	167	M32 x 1.5	4L	35
(IE1-)K21R 160 MX2	45	45	160	18	417	351	332	138	15	20	571	686	63 A	193	167	M40 x 1.5	4L	35
(IE1-)K21R 160 L2, 4, 6, 8	45	45	160	18	417	351	332	138	15	20	609	724	63 A	193	167	M40 x 1.5	4L	35
(IE1-)K21R 180 M4	51.5	45	180	20	417	351	352	138	15	20	609	724	63 A	193	167	M40 x 1.5	4L	35
(IE1-)K21R 180 L6, 8	51.5	45	180	20	417	364	352	138	15	20	609	724	63 A	193	167	M40 x 1.5	4L	35

^{*)} Terminal box left/right

Three-phase motors with squirrel-cage rotor for use in powered smoke and heat extraction systems to EN 12101-3
Energy-saving motor, efficiency class Standard Efficiency IE1

Surface cooling, type of cooling IC 411, degree of protection IP 55
 Size 132 to 280

Type of construction IM B5 [IM 3001]
Type of construction IM V1 [IM 3011]

Flange dimensions, see page 8/23

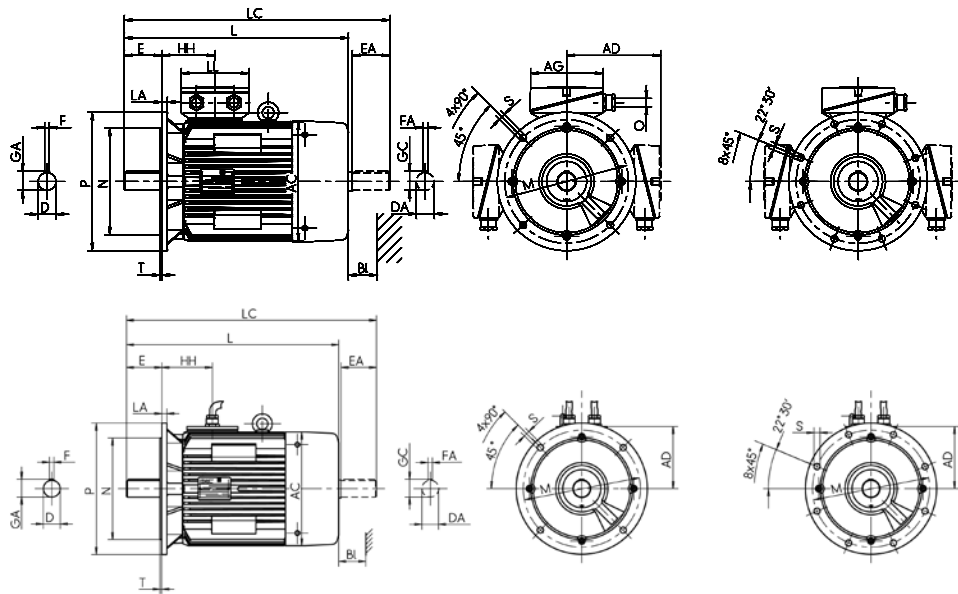

Type designation	Flange size	AC g	AD g1	AD g1	D d	DA d1	DB ¹⁾	E l	EA l1	F u	FA u1	GA t	GC t1	H h	HH A	L k	LC k1	TB	Type	AG	LL	O	Hole	BI
				with TB Cable																				pattern BI
(IE1-)K21R 132 M4	FF265	258	199	144	38	38	M12	80	80	10	10	41	41	132	114	481	565	25 A	156	145	M32 x 1.5	4L	35	
(IE1-)K21R 132 MX6	FF265	258	199	144	38	38	M12	80	80	10	10	41	41	132	114	481	565	25 A	156	145	M32 x 1.5	4L	35	
(IE1-)K21R 160 M2	FF300	258	214	144	42	38	M16	110	80	12	10	45	41	160	114	559	643	25 A	156	145	M32 x 1.5	4L	35	
(IE1-)K21R 160 M4, 6, 8	FF300	258	214	144	42	38	M16	110	80	12	10	45	41	160	114	559	643	25 A	156	145	M32 x 1.5	4L	35	
(IE1-)K21R 160 MX8	FF300	258	199	144	42	38	M16	110	80	12	10	45	41	160	114	559	643	25 A	156	145	M32 x 1.5	4L	35	
(IE1-)K21R 160 MX2	FF300	313	242	172	42	42	M16	110	110	12	12	45	45	160	138	571	686	63 A	193	167	M40 x 1.5	4L	35	
(IE1-)K21R 160 L2, 4, 6, 8	FF300	313	242	172	42	42	M16	110	110	12	12	45	45	160	138	609	724	63 A	193	167	M40 x 1.5	4L	35	
(IE1-)K21R 180 M2	FF300	351	261	191	48	48	M16	110	110	14	14	51.5	51.5	180	147	635	751	63 A	193	167	M40 x 1.5	4L	35	
(IE1-)K21R 180 M4	FF300	313	242	172	48	42	M16	110	110	14	12	51.5	45	180	138	609	724	63 A	193	167	M40 x 1.5	4L	35	
(IE1-)K21R 180 L4	FF300	351	261	191	48	48	M16	110	110	14	14	51.5	51.5	180	147	680	796	63 A	193	167	M40 x 1.5	4L	35	
(IE1-)K21R 180 L6, 8	FF300	313	242	172	48	42	M16	110	110	14	12	51.5	45	180	138	609	724	63 A	193	167	M40 x 1.5	4L	35	
(IE1-)K21R 200 L2, 4, 6, 8	FF 350	351	261	191	55	48	M20	110	110	16	14	59	51.5	200	147	680	796	63 A	193	167	M40 x 1.5	4L	35	
(IE1-)K21R 200 LX6	FF 350	351	261	191	55	48	M20	110	110	16	14	59	51.5	200	147	680	796	63 A	193	167	M40 x 1.5	4L	35	
(IE1-)K21R 200 LX2	FF 350	390	300	211	55	55	M20	110	110	16	16	59	59	200	168	727	851	100 A	213	207	M50 x 1.5	4L	35	
(IE1-)K21R 225 S4, 8	FF 400	390	300	211	60	55	M20	140	110	18	16	64	59	225	168	757	881	100 A	213	207	M50 x 1.5	8L	40	
(IE1-)K21R 225 M2	FF 400	390	300	211	55	55	M20	110	110	16	16	59	59	225	168	767	891	100 A	213	207	M50 x 1.5	8L	40	
(IE1-)K21R 225 M4	FF 400	390	300	211	60	55	M20	140	110	18	16	64	59	225	168	797	921	100 A	213	207	M50 x 1.5	8L	40	
(IE1-)K21R 225 M6, 8	FF 400	390	300	211	60	55	M20	140	110	18	16	64	59	225	168	757	881	100 A	213	207	M50 x 1.5	8L	40	
(IE1-)K21R 250 M2	FF 500	440	358	235	60	55	M20	140	110	18	16	64	59	250	177	862	977	200 A	282	242	M63 x 1.5	8L	45	
(IE1-)K21R 250 M4, 6, 8	FF 500	440	358	235	65	55	M20	140	110	18	16	69	59	250	177	862	977	200 A	282	242	M63 x 1.5	8L	45	
(IE1-)K21R 280 S2	FF 500	490	386	285	65	65	M20	140	140	18	18	69	69	280	206	924	1072	200 A	282	242	M63 x 1.5	8L	50	
(IE1-)K21R 280 S4, 6, 8	FF 500	490	386	285	75	65	M20	140	140	20	18	79.5	69	280	206	924	1072	200 A	282	242	M63 x 1.5	8L	50	
(IE1-)K21R 280 M2	FF 500	490	386	285	65	65	M20	140	140	18	18	69	69	280	206	970	1118	200 A	282	242	M63 x 1.5	8L	50	
(IE1-)K21R 280 M4, 6, 8	FF 500	490	386	285	75	65	M20	140	140	20	18	79.5	69	280	206	970	1118	200 A	282	242	M63 x 1.5	8L	50	

¹⁾ Centre holes to DIN 332-DS

²⁾ Terminal box left/right

Three-phase motors with squirrel-cage rotor for use in powered smoke and heat extraction systems to EN 12101-3
Energy-saving motor, efficiency class Standard Efficiency IE1

Surface cooling, type of cooling IC 411, degree of protection IP 55
 Size 315

Type of construction IM B5 [IM 3001]
Type of construction IM V1 [IM 3011]

Flange dimensions, see page 8/23

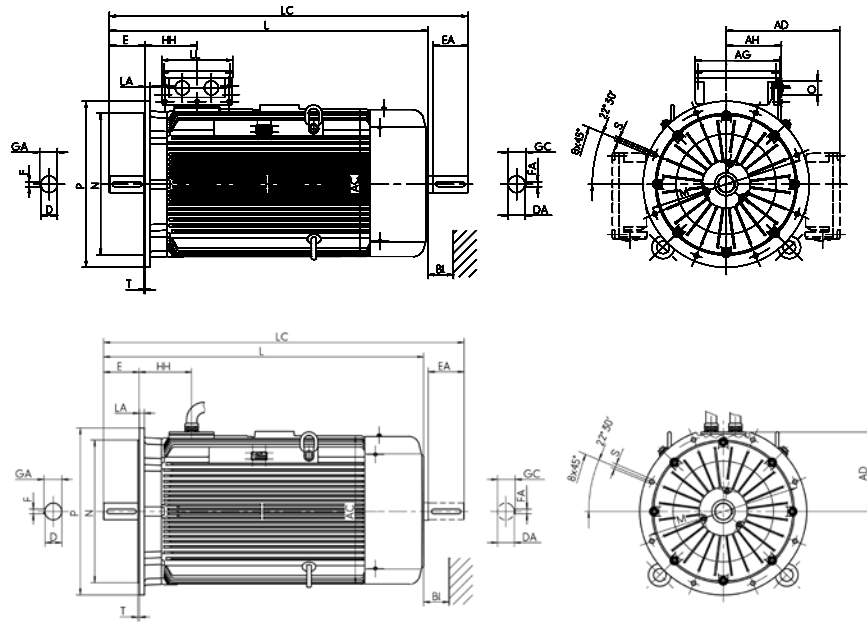

Type designation	Flange size	AC g	AD g1	AD g1	D d	DA d1	DB ¹⁾	E l	EA l1	F u	FA u1	GA t	GC t1	H h	HH A	L k	LC k1	TB	Type	AG x	LL z	AH -	O r	BI Bl
(IE1-)K21R 315 S2	FF 600	550	416	315	65	65	M20	140	140	18	18	69	69	315	211	1050	1218	200	A	282	242	-	M63 x 1.5	55
(IE1-)K21R 315 S4, 6, 8	FF 600	550	416	315	80	70	M20	170	140	22	20	85	74.5	315	211	1080	1248	200	A	282	242	-	M63 x 1.5	55
(IE1-)K21R 315 M2	FF 600	550	416	315	65	65	M20	140	140	18	18	69	69	315	211	1105	1273	200	A	282	242	-	M63 x 1.5	55
(IE1-)K21R 315 M4, 6, 8	FF 600	550	416	315	80	70	M20	170	140	22	20	85	74.5	315	211	1135	1303	200	A	282	242	-	M63 x 1.5	55
(IE1-)K21R 315 MX2	FF 600	550	416	315	65	65	M20	140	140	18	18	69	69	315	211	1185	1353	200	A	282	242	-	M63 x 1.5	55
(IE1-)K21R 315 MX4	FF 600	550	416	315	80	70	M20	170	140	22	20	85	74.5	315	211	1215	1383	200	A	282	242	-	M63 x 1.5	55
(IE1-)K21R 315 MX6, 8	FF 600	550	416	315	80	70	M20	170	140	22	20	85	74.5	315	211	1135	1303	200	A	282	242	-	M63 x 1.5	55
(IE1-)K21R 315 MX10, 12	FF 600	550	416	315	80	70	M20	170	140	22	20	85	74.5	315	211	1135	1303	200	A	282	242	-	M63 x 1.5	55
(IE1-)K21R 315 MY2	FF 600	610	494	348	65	65	M20	140	140	18	18	69	69	315	230	1270	1448	400	B	415	340	265	M63 x 1.5	55
(IE1-)K21R 315 MY4, 6, 8	FF 600	610	494	348	80	70	M20	170	140	22	20	85	74.5	315	230	1300	1478	400	B	415	340	265	M63 x 1.5	55
(IE1-)K21R 315 L2	FF 600	610	494	348	65	65	M20	140	140	18	18	69	69	315	230	1390	1543	400	B	415	340	265	M63 x 1.5	55
(IE1-)K21R 315 L4, 6, 8	FF 600	610	494	348	80	70	M20	170	140	22	20	85	74.5	315	230	1420	1598	400	B	415	340	265	M63 x 1.5	55
(IE1-)K21R 315 LX2	FF 600	610	494	348	65	65	M20	140	140	18	18	69	69	315	230	1510	1688	400	B	415	340	265	M63 x 1.5	55
(IE1-)K21R 315 LX4	FF 600	610	494	348	80	70	M20	170	140	22	20	85	74.5	315	230	1540	1723	400	B	415	340	265	M63 x 1.5	55
(IE1-)K21R 315 LX6, 8	FF 600	610	494	348	80	70	M20	170	140	22	20	85	74.5	315	230	1420	1598	400	B	415	340	265	M63 x 1.5	55

¹⁾ Centre holes to DIN 332-DS

Three-phase motors with squirrel-cage rotor for use in powered smoke and heat extraction systems to EN 12101-3
Energy-saving motor, efficiency class Standard Efficiency IE1

Surface cooling, type of cooling IC 411, degree of protection IP 55
 Size 355

Type of construction IM B5 [IM 3001]

Type of construction IM V1 [IM 3011]

Flange dimensions, see page 8/23

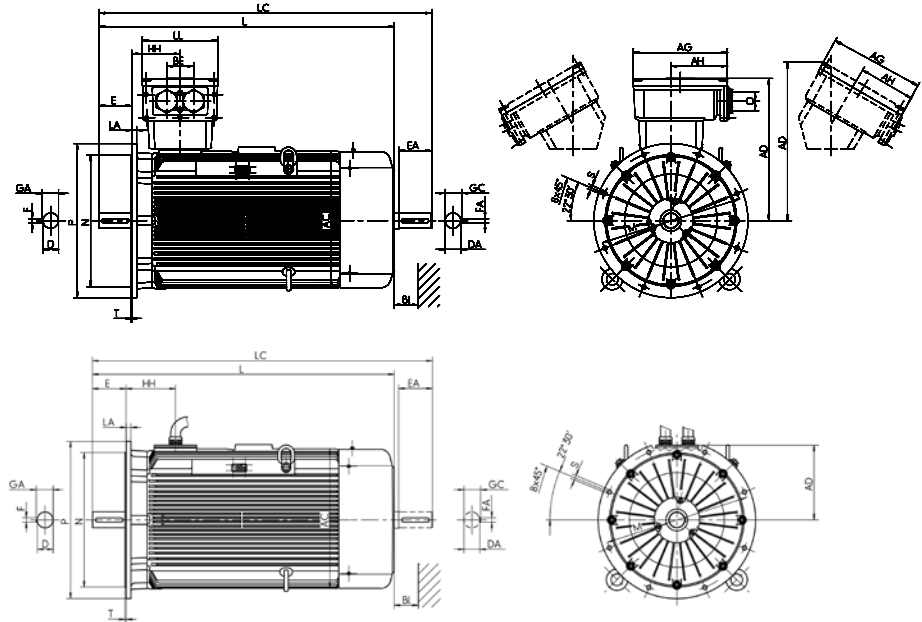

Type designation	Flange size	AC	AD	AD **)	AD	D	DA	DB *)	E	EA	F	FA	GA	GC	H	HH	L	LC	TB Type	AG	LL	AH	BE	0	BI
		g	g1	g1	g1	d	d1		l	l1	u	u1	t	t1	h	A	K	K1	Standard VIK	x	z	-	-	r	BI
		VIK ¹⁾	x	z	-	-	r	BI																	
(IE1-)K22R 355 MY2, M2	FF 740	715	736	817	484	80	80	M20	170	170	22	22	85	85	355	250	1530	1715	630 A	496	390	301	140	M72 x 2	60
(IE1-)K22R 355 MY4, 6, 8	FF 740	715	736	817	484	100	80	M24	210	170	28	22	106	85	355	250	1570	1755	630 A	496	390	301	140	M72 x 2	60
(IE1-)K22R 355 M4	FF 740	715	736	817	484	100	80	M24	210	170	28	22	106	85	355	250	1570	1755	630 A	496	390	301	140	M72 x 2	60
(IE1-)K22R 355 M6, 8	FF 740	715	736	817	484	100	80	M24	210	170	28	22	106	85	355	250	1570	1755	630 A	496	390	301	140	M72 x 2	60
(IE1-)K22R 355 MX6, 8	FF 740	715	736	817	484	100	80	M24	210	170	28	22	106	85	355	250	1690	1875	630 A	496	390	301	140	M72 x 2	60
(IE1-)K22R 355 MX2	FF 740	715	728	819	484	80	80	M20	170	170	22	22	85	85	355	327	1650	1835	1000 A	615	474	385	200	M72 x 2	60
(IE1-)K22R 355 LY2, L2	FF 740	715	728	819	484	80	80	M20	170	170	22	22	85	85	355	327	1650	1835	1000 A	615	474	385	200	M72 x 2	60
(IE1-)K22R 355 MX4	FF 740	715	728	819	484	100	80	M24	210	170	28	22	106	85	355	327	1690	1875	1000 A	615	474	385	200	M72 x 2	60
(IE1-)K22R 355 LY, L4	FF 740	715	728	819	484	100	80	M24	210	170	28	22	106	85	355	327	1690	1875	1000 A	615	474	385	200	M72 x 2	60
(IE1-)K22R 355 LY6, 8	FF 740	715	728	819	484	100	80	M24	210	170	28	22	106	85	355	327	1690	1875	1000 A	615	474	385	200	M72 x 2	60

¹⁾ Centre holes to DIN 332-DS
²⁾ Terminal box inclined left/right

Three-phase motors with squirrel-cage rotor for use in powered smoke and heat extraction systems to EN 12101-3
Energy-saving motor, efficiency class Standard Efficiency IE1

Transnorm version
 Surface cooling, type of cooling IC 411, degree of protection IP 55
 Size 132 to 250

Type of construction IM B3 [IM 1001]

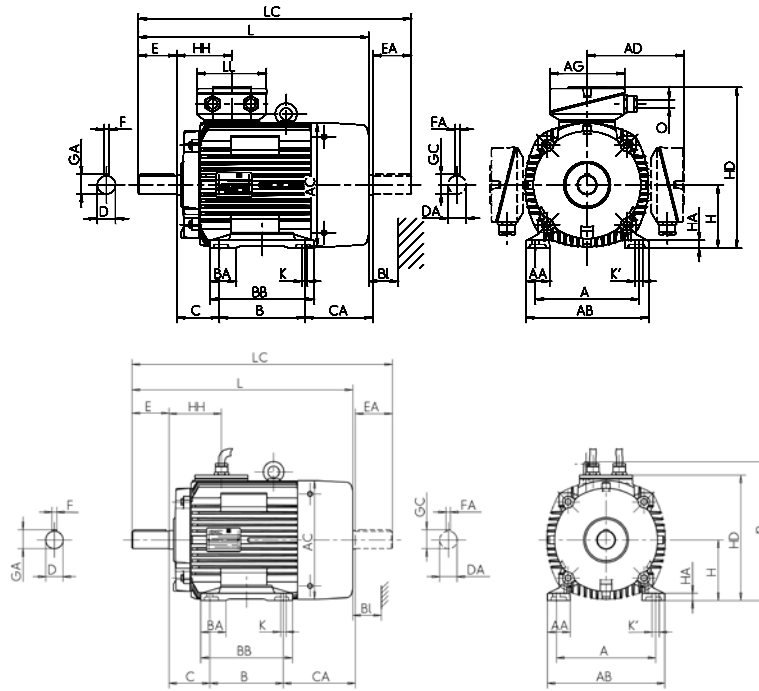

Type designation	Flange size	A	AA	AB	AC	AD	AD	B	BA	BB	C	CA	D	DA	DB ¹⁾	E	EA	F	FA
		b	n	f	g	g1	g1	a	m	e	w1	w2	d	d1		l	l1	u	u1
(IE1-)K20R 132 S	FF 300	216	50	256	258	199	140	140	47	180	89	176	38	38	M12	80	80	10	10
(IE1-)K20R 132 M	FF 300	216	50	256	258	199	140	178	47	218	89	186	38	38	M12	80	80	10	10
(IE1-)K20R 160 S2	FF 300	254	55	296	313	242	169	178	56	225	108	180	42	42	M16	110	110	12	12
(IE1-)K20R 160 S4, 6, 8	FF 300	254	55	296	313	242	169	178	56	225	108	180	48	42	M16	110	110	14	12
(IE1-)K20R 160 M2	FF 300	254	55	296	313	242	169	210	56	257	108	186	42	42	M16	110	110	12	12
(IE1-)K20R 160 M4, 6, 8	FF 300	254	55	296	313	242	169	210	56	257	108	186	48	42	M16	110	110	14	12
(IE1-)K20R 180 S2	FF 350	279	62	328	351	261	187	203	65	250	121	207	48	48	M16	110	110	14	14
(IE1-)K20R 180 S4, 6, 8	FF 350	279	62	328	351	261	187	203	65	250	121	207	55	48	M20	110	110	16	14
(IE1-)K20R 180 M2	FF 350	279	62	328	351	261	187	241	65	288	121	214	48	48	M16	110	110	14	14
(IE1-)K20R 180 M4, 6, 8	FF 350	279	62	328	351	261	187	241	65	288	121	214	55	48	M20	110	110	16	14
(IE1-)K20R 200 M2	FF 400	318	70	372	390	300	209	267	70	322	133	231	55	55	M20	110	110	16	16
(IE1-)K20R 200 M4, 6, 8	FF 400	318	70	372	390	300	209	267	70	322	133	231	60	55	M20	140	110	18	16
(IE1-)K20R 200 L2	FF 400	318	70	372	390	300	209	305	70	360	133	233	55	55	M20	110	110	16	16
(IE1-)K20R 200 L4, 6, 8	FF 400	318	70	372	390	300	209	305	70	360	133	233	60	55	M20	140	110	18	16
(IE1-)K20R 225 M2	FF 500	356	75	413	440	324	233	311	75	368	149	267	55	55	M20	110	110	16	16
(IE1-)K20R 225 M4, 6, 8	FF 500	356	75	413	440	324	233	311	75	368	149	267	65	55	M20	140	110	18	16
(IE1-)K20R 250 S2	FF 500	406	84	469	490	386	263	311	84	374	168	313	65	65	M20	140	140	18	18
(IE1-)K20R 250 S4, 6, 8	FF 500	406	84	469	490	386	263	311	84	374	168	313	75	65	M20	140	140	20	18
(IE1-)K20R 250 M2	FF 500	406	84	469	490	386	263	349	84	412	168	275	65	65	M20	140	140	18	18
(IE1-)K20R 250 M4, 6, 8	FF 500	406	84	469	490	386	263	349	84	412	168	321	75	65	M20	140	140	20	18

¹⁾ Centre holes to DIN 332-DS

Three-phase motors with squirrel-cage rotor for use in powered smoke and heat extraction systems to EN 12101-3
Energy-saving motor, efficiency class Standard Efficiency IE1

Transnorm version
 Surface cooling, type of cooling IC 411, degree of protection IP 55
 Size 132 to 250
 Size 112 to 160 with crowned flange

Type of construction IM B35 [IM 2001]

Flange dimensions, see page 8/23

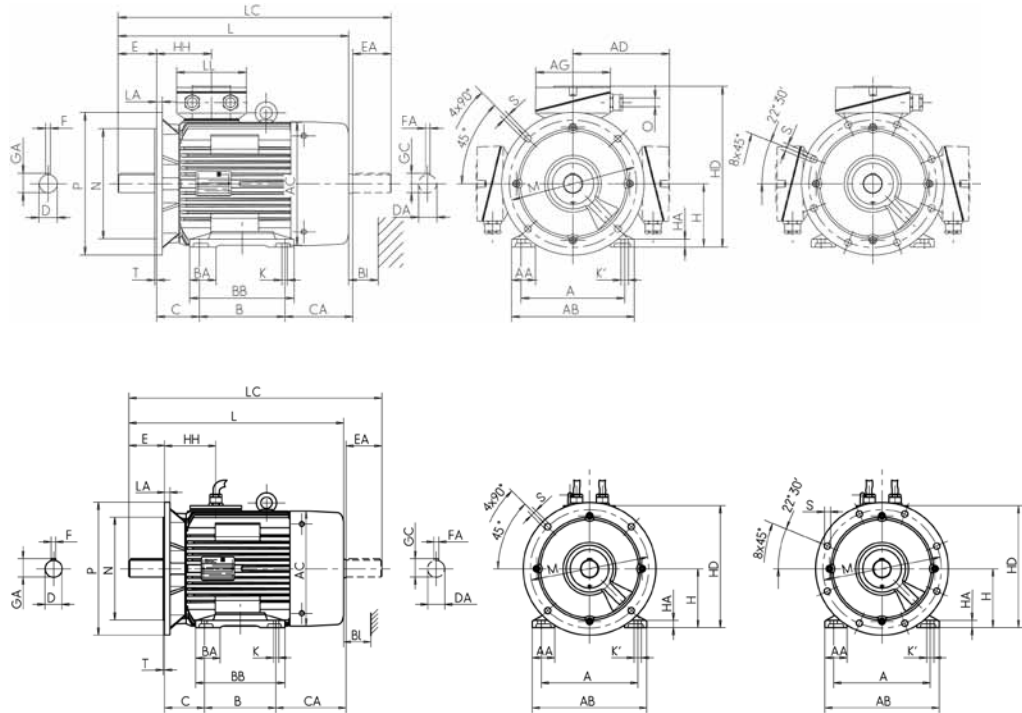

Type designation	GA	GC	H	HA	HD	HD ^{**})	HD	HH	K	K'	L	LC	TB Type	AG	LL	O	Hole	BI
	t	t1	h	c	p	p	p	A	s	s'	k	k1					pattern	BI
(IE1-)K20R 132 S	41	41	132	15	331	279	276	114	12	12	481	565	25 A	156	145	M32 x 1.5	4L	35
(IE1-)K20R 132 M	41	41	132	15	331	279	276	114	12	12	529	613	25 A	156	145	M32 x 1.5	4L	35
(IE1-)K20R 160 S2	45	45	160	18	402	336	332	138	15	20	571	686	63 A	193	167	M40 x 1.5	4L	35
(IE1-)K20R 160 S4, 6, 8	51.5	45	160	18	402	336	332	138	15	20	571	686	63 A	193	167	M40 x 1.5	4L	35
(IE1-)K20R 160 M2	45	45	160	18	402	336	332	138	15	20	609	724	63 A	193	167	M40 x 1.5	4L	35
(IE1-)K20R 160 M4, 6, 8	51.5	45	160	18	402	336	332	138	15	20	609	724	63 A	193	167	M40 x 1.5	4L	35
(IE1-)K20R 180 S2	51.5	51.5	180	20	441	369	371	147	15	20	635	751	63 A	193	167	M40 x 1.5	4L	35
(IE1-)K20R 180 S4, 6, 8	59	51.5	180	20	441	369	371	147	15	20	635	751	63 A	193	167	M40 x 1.5	4L	35
(IE1-)K20R 180 M2	51.5	51.5	180	20	441	369	371	147	15	20	680	796	63 A	193	167	M40 x 1.5	4L	35
(IE1-)K20R 180 M4, 6, 8	59	51.5	180	20	441	369	371	147	15	20	680	796	63 A	193	167	M40 x 1.5	4L	35
(IE1-)K20R 200 M2	59	59	200	22	500	417	411	168	19	25	727	851	100 A	213	207	M50 x 1.5	4L	40
(IE1-)K20R 200 M4, 6, 8	64	59	200	22	500	417	411	168	19	25	757	881	100 A	213	207	M50 x 1.5	4L	40
(IE1-)K20R 200 L2	59	59	200	22	500	417	411	168	19	25	767	891	100 A	213	207	M50 x 1.5	4L	40
(IE1-)K20R 200 L4, 6, 8	64	59	200	22	500	417	411	168	19	25	797	921	100 A	213	207	M50 x 1.5	4L	40
(IE1-)K20R 225 M2	59	59	225	25	549	459	460	177	19	25	832	947	100 A	213	207	M50 x 1.5	8L	45
(IE1-)K20R 225 M4, 6, 8	69	59	225	25	549	459	460	177	19	25	862	977	100 A	213	207	M50 x 1.5	8L	45
(IE1-)K20R 250 S2	69	69	250	28	636	493	513	206	24	30	924	1072	200 A	282	242	M63 x 1.5	8L	50
(IE1-)K20R 250 S4, 6, 8	79.5	69	250	28	636	493	513	206	24	30	924	1072	200 A	282	242	M63 x 1.5	8L	50
(IE1-)K20R 250 M2	69	69	250	28	636	493	513	206	24	30	924	1072	200 A	282	242	M63 x 1.5	8L	50
(IE1-)K20R 250 M4, 6, 8	79.5	69	250	28	636	493	513	206	24	30	970	1118	200 A	282	242	M63 x 1.5	8L	50

** Terminal box left/right

**Three-phase motors with squirrel-cage rotor for use in powered smoke and heat extraction systems to EN 12101-3
Energy-saving motor, efficiency class Standard Efficiency IE1**

Transnorm version
Surface cooling, type of cooling IC 411, degree of protection IP 55
Size 280, 315

Type of construction IM B3 [IM 1001]

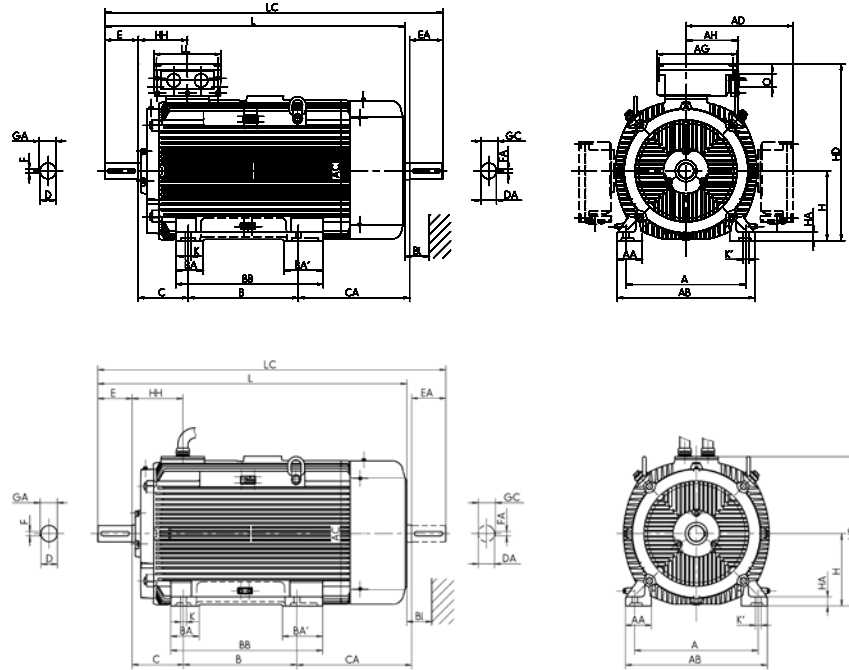

Type designation	Flange size	A	AA	AB	AC	AD	B	BA	BA'	BB	C	CA	D	DA	DB *)	E	EA	F	FA
		b	n	f	g	g1	a	m	m1	e	w1	w2	d	d1		l	l1	u	u1
(IE1-)K20R 280 S2	FF 600	457	88	522	550	416	368	94	-	431	190	380	70	70	M20	140	140	20	20
(IE1-)K20R 280 S4, 6, 8	FF 600	457	88	522	550	416	368	94	-	431	190	380	80	70	M20	170	140	22	20
(IE1-)K20R 280 M2	FF 600	457	88	522	550	416	419	94	-	482	190	384	70	70	M20	140	140	20	20
(IE1-)K20R 280 M4, 6, 8	FF 600	457	88	522	550	416	419	94	-	482	190	384	80	70	M20	170	140	22	20
(IE1-)K20R 315 S2	FF 600	508	132	590	550	416	406	120	150	554	216	451	75	70	M20	140	140	20	20
(IE1-)K20R 315 S4	FF 600	508	132	590	550	416	406	120	150	554	216	451	90	70	M24	170	140	25	20
(IE1-)K20R 315 S6, 8	FF 600	508	132	590	550	416	406	120	150	554	216	371	90	70	M24	170	140	25	20
(IE1-)K20R 315 M2	FF 600	508	110	590	610	498	457	120	-	573	216	495	75	75	M20	140	140	20	20
(IE1-)K20R 315 M4, 6, 8	FF 600	508	110	590	610	498	457	120	-	573	216	495	90	75	M24	170	140	25	20
(IE1-)K20R 315 M10, 12	FF 600	508	132	590	550	498	457	120	150	554	216	320	90	75	M24	170	140	25	20
(IE1-)K20R 315 L2	FF 600	508	110	590	610	498	508	120	-	624	216	564	75	75	M20	140	140	20	20
(IE1-)K20R 315 L4, 6, 8	FF 600	508	110	590	610	498	508	120	-	624	216	564	90	75	M24	170	140	25	20
(IE1-)K20R 315 LX2	FF 600	508	110	590	610	481	508	120	-	624	216	684	75	75	M20	140	140	20	20
(IE1-)K20R 315 LX4	FF 600	508	110	590	610	481	508	120	-	624	216	684	90	75	M24	170	140	25	20
(IE1-)K20R 315 LX6, 8	FF 600	508	110	590	610	498	508	120	-	624	216	564	90	75	M24	170	140	25	20

*) Centre holes to DIN 332-DS

Three-phase motors with squirrel-cage rotor for use in powered smoke and heat extraction systems to EN 12101-3
Energy-saving motor, efficiency class Standard Efficiency IE1

Transnorm version
 Surface cooling, type of cooling IC 411, degree of protection IP 55
 Size 280, 315

Type of construction IM B35 [IM 2001]

Flange dimensions, see page 8/23

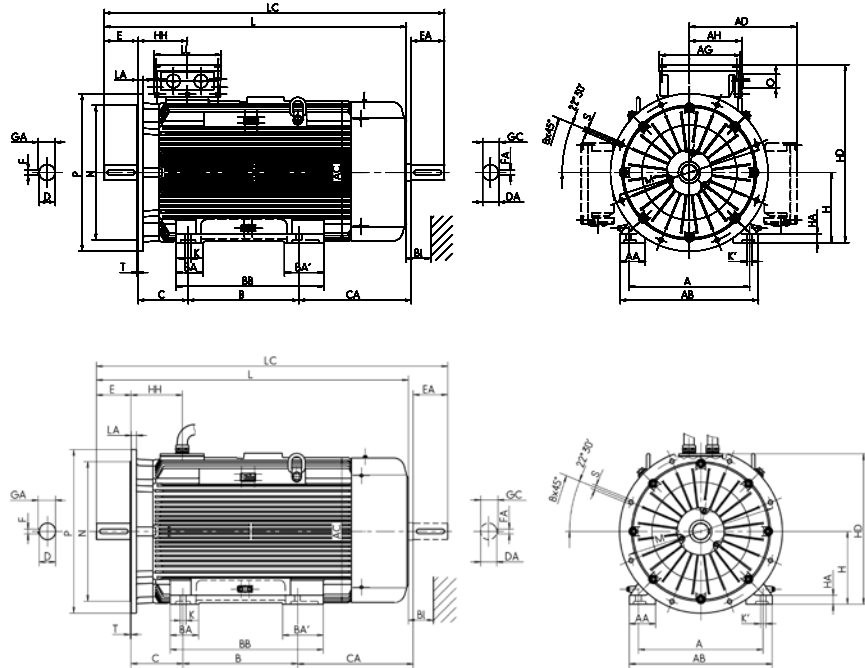

Type designation	GA	GC	H	HA	HD	HD** with TB	HD Cable	HH	K	K'	L	LC	TB Type	AG	LL	AH	O	BI
	t	t1	h	c	p	p	p	A	s	s'	k	k1		x	z	-	r	BI
(IE1-)K20R 280 S2	74.5	74.5	280	40	696	560	595	211	24	30	1050	1218	200 A	282	242	-	M63 x 1.5	55
(IE1-)K20R 280 S4, 6, 8	85	74.5	280	40	696	560	595	211	24	30	1080	1248	200 A	282	242	-	M63 x 1.5	55
(IE1-)K20R 280 M2	74.5	74.5	280	40	696	560	595	211	24	30	1105	1273	200 A	282	242	-	M63 x 1.5	55
(IE1-)K20R 280 M4, 6, 8	85	74.5	280	40	696	560	595	211	24	30	1135	1303	200 A	282	242	-	M63 x 1.5	55
(IE1-)K20R 315 S2	79.5	74.5	315	44	731	595	630	211	28	35	1185	1353	200 A	282	242	-	M63 x 1.5	55
(IE1-)K20R 315 S4	95	74.5	315	44	731	595	630	211	28	35	1215	1383	200 A	282	242	-	M63 x 1.5	55
(IE1-)K20R 315 S6, 8	95	74.5	315	44	731	595	630	211	28	35	1135	1303	200 A	282	242	-	M63 x 1.5	55
(IE1-)K20R 315 M2	79.5	79.5	315	44	809	628	663	230	28	35	1270	1448	400 B	315	294	265	M63 x 1.5	55
(IE1-)K20R 315 M4, 6, 8	95	79.5	315	44	809	628	663	230	28	35	1300	1478	400 B	315	294	265	M63 x 1.5	55
(IE1-)K20R 315 M10, 12	95	79.5	315	44	774	595	630	211	28	35	1135	1303	400 B	315	294	265	M63 x 1.5	55
(IE1-)K20R 315 L2	79.5	79.5	315	44	809	628	663	230	28	35	1390	1568	400 B	315	294	265	M63 x 1.5	55
(IE1-)K20R 315 L4, 6, 8	95	79.5	315	44	809	628	663	230	28	35	1420	1598	400 B	315	294	265	M63 x 1.5	55
(IE1-)K20R 315 LX2	79.5	79.5	315	44	809	628	663	230	28	35	1510	1688	400 B	315	294	265	M63 x 1.5	55
(IE1-)K20R 315 LX4	95	79.5	315	44	809	628	663	230	28	35	1540	1718	400 B	315	294	265	M63 x 1.5	55
(IE1-)K20R 315 LX6, 8	95	79.5	315	44	809	628	663	230	28	35	1420	1598	400 B	315	294	265	M63 x 1.5	55

** Terminal box left/right

Three-phase motors with squirrel-cage rotor for use in powered smoke and heat extraction systems to EN 12101-3
Energy-saving motor, efficiency class Standard Efficiency IE1

Transnorm version
 Surface cooling, type of cooling IC 411, degree of protection IP 55
 Size 132 to 160

Type of construction IM B14 [IM 3601]
 Flange dimensions, see page 8/23

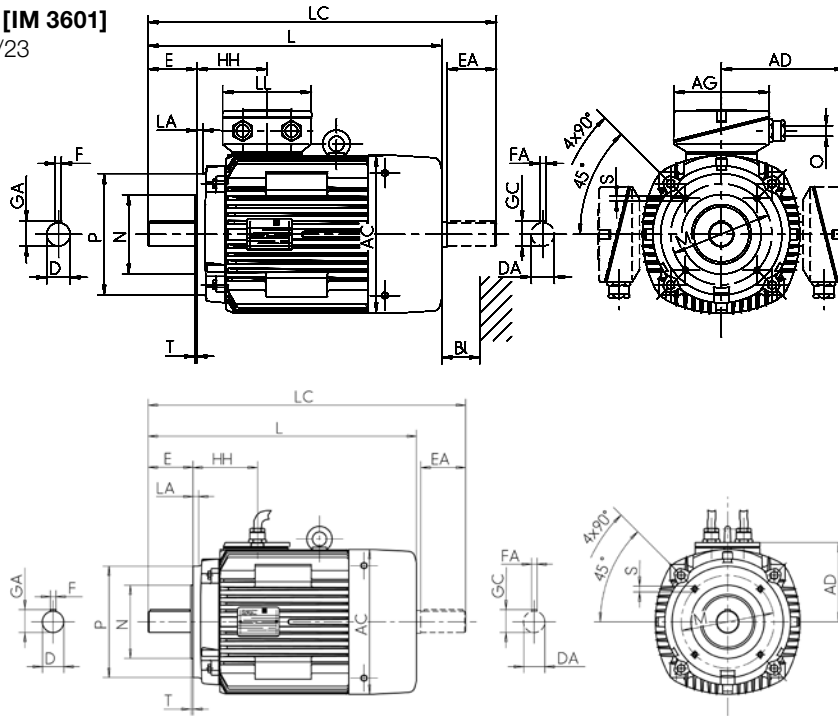

Type designation	Flange size		A	AA	AB	AC	AD	AD	B	BA	BB	C	CA	D	DA	DB ¹⁾	E	EA	F	FA
	small	large	b	n	f	g	g1	g1	a	m	e	w1	w2	d	d1		l	l1	u	u1
	with TB Cable																			
(IE1-)K20R 132 S	FT 165	FT 215	216	50	256	258	199	140	140	47	180	89	176	38	38	M12	80	80	10	10
(IE1-)K20R 132 M	FT 165	FT 215	216	50	256	258	199	140	178	47	218	89	186	38	38	M12	80	80	10	10
(IE1-)K20R 160 S2	FT 215	FT 265	254	55	296	313	242	169	178	56	225	108	180	42	42	M16	110	110	12	12
(IE1-)K20R 160 S4, 6, 8	FT 215	FT 265	254	55	296	313	242	169	178	56	225	108	180	48	42	M16	110	110	14	12
(IE1-)K20R 160 M2	FT 215	FT 265	254	55	296	313	242	169	210	56	257	108	186	42	42	M16	110	110	12	12
(IE1-)K20R 160 M4, 6, 8	FT 215	FT 265	254	55	296	313	242	169	210	56	257	108	186	48	42	M16	110	110	14	12

¹⁾ Centre holes to DIN 332-DS

Three-phase motors with squirrel-cage rotor for use in powered smoke and heat extraction systems to EN 12101-3
Energy-saving motor, efficiency class Standard Efficiency IE1

Transnorm version
 Surface cooling, type of cooling IC 411, degree of protection IP 55
 Size 132 to 160

Type of construction IM B34 [IM 2101]

Flange dimensions, see page 8/23

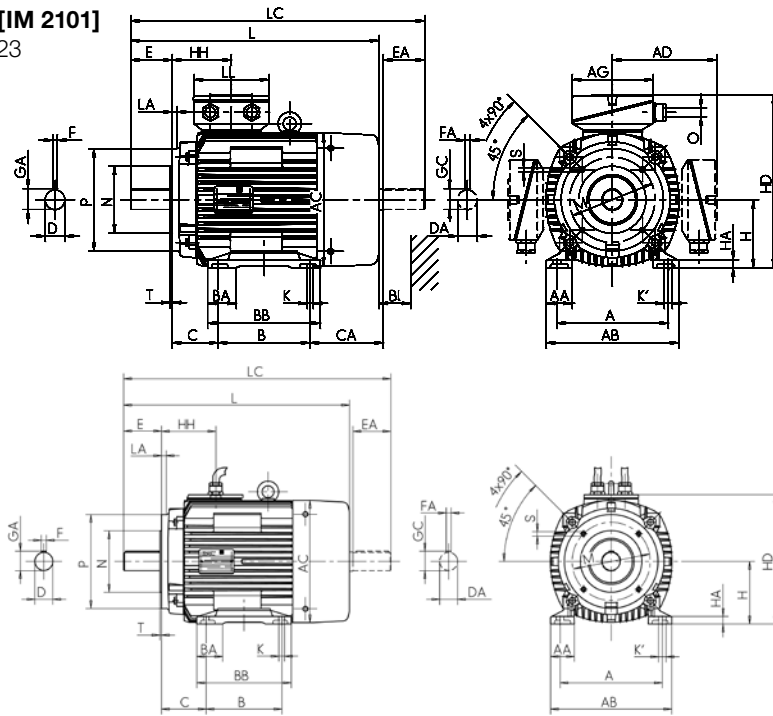

Type designation	GA	GC	H	HA	HD	HD ^{*)}	HD	HH	K	K'	L	LC	TB Type	AG	LL	O	Hole	BI
	t	t1	h	c	p	p	p	A	s	s'	k	k1					pattern	BI
(IE1-)K20R 132 S	41	41	132	15	331	279	276	114	12	12	481	565	25 A	156	145	M32 x 1.5	4L	35
(IE1-)K20R 132 M	41	41	132	15	331	279	276	114	12	12	529	613	25 A	156	145	M32 x 1.5	4L	35
(IE1-)K20R 160 S2	45	45	160	18	402	336	332	138	15	20	571	686	63 A	193	167	M40 x 1.5	4L	35
(IE1-)K20R 160 S4, 6, 8	51.5	45	160	18	402	336	332	138	15	20	571	686	63 A	193	167	M40 x 1.5	4L	35
(IE1-)K20R 160 M2	45	45	160	18	402	336	332	138	15	20	609	724	63 A	193	167	M40 x 1.5	4L	35
(IE1-)K20R 160 M4, 6, 8	51.5	45	160	18	402	336	332	138	15	20	609	724	63 A	193	167	M40 x 1.5	4L	35

^{*)} Terminal box left/right

Three-phase motors with squirrel-cage rotor for use in powered smoke and heat extraction systems to EN 12101-3
Energy-saving motor, efficiency class Standard Efficiency IE1

Transnorm version
 Surface cooling, type of cooling IC 411, degree of protection IP 55
 Size 132 to 250

Type of construction IM B5 [IM 3001]
Type of construction IM V1 [IM 3011]

Flange dimensions, see page 8/23

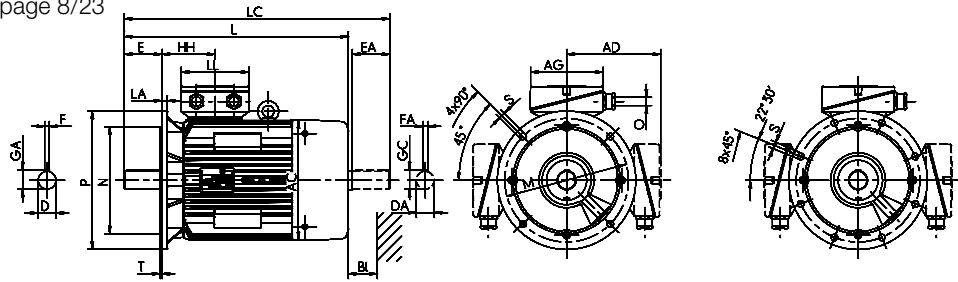

Size 160 with crowned flange

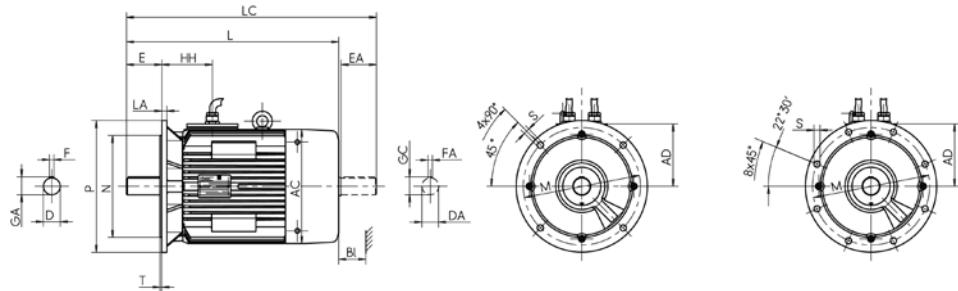

Type designation	Flange size	AC g	AD g1	AD g1	D d	DA d1	DB ⁷⁾	E l	EA l1	F u	FA u1	GA t	GC t1	H h	HH A	L k	LC k1	TB	Type	AG	LL	O	Hole	BI
																								pattern BI
(IE1-)K20R 132 S	FF 300	258	199	140	38	38	M12	80	80	10	10	41	41	132	114	481	565	25	A	156	145	M32x1.5	4L	35
(IE1-)K20R 132 M	FF 300	258	199	140	38	38	M12	80	80	10	10	41	41	132	114	529	613	25	A	156	145	M32x1.5	4L	35
(IE1-)K20R 160 S2	FF 300	313	242	169	42	42	M16	110	110	12	12	45	45	160	138	571	686	63	A	193	167	M40x1.5	4L	35
(IE1-)K20R 160 S4, 6, 8	FF 300	313	242	169	48	42	M16	110	110	14	12	51.5	45	160	138	571	686	63	A	193	167	M40x1.5	4L	35
(IE1-)K20R 160 M2	FF 300	313	242	169	42	42	M16	110	110	12	12	45	45	160	138	609	724	63	A	193	167	M40x1.5	4L	35
(IE1-)K20R 160 M4, 6, 8	FF 300	313	242	169	48	42	M16	110	110	14	12	51.5	45	160	138	609	724	63	A	193	167	M40x1.5	4L	35
(IE1-)K20R 180 S2	FF 350	351	261	187	48	48	M16	110	110	14	14	51.5	51.5	180	147	635	751	63	A	193	167	M40x1.5	4L	35
(IE1-)K20R 180 S4, 6, 8	FF 350	351	261	187	55	48	M20	110	110	16	14	59	51.5	180	147	635	751	63	A	193	167	M40x1.5	4L	35
(IE1-)K20R 180 M2	FF 350	351	261	187	48	48	M16	110	110	14	14	51.5	51.5	180	147	680	796	63	A	193	167	M40x1.5	4L	35
(IE1-)K20R 180 M4, 6, 8	FF 350	351	261	187	55	48	M20	110	110	16	14	59	51.5	180	147	680	796	63	A	193	167	M40x1.5	4L	35
(IE1-)K20R 200 M2	FF 400	390	300	209	55	55	M20	110	110	16	16	59	59	200	168	727	851	100	A	213	207	M50x1.5	4L	40
(IE1-)K20R 200 M4, 6, 8	FF 400	390	300	209	60	55	M20	140	110	18	16	64	59	200	168	757	881	100	A	213	207	M50x1.5	4L	40
(IE1-)K20R 200 L2	FF 400	390	300	209	55	55	M20	110	110	16	16	59	59	200	168	767	891	100	A	213	207	M50x1.5	4L	40
(IE1-)K20R 200 L4, 6, 8	FF 400	390	300	209	60	55	M20	140	110	18	16	64	59	200	168	797	921	100	A	213	207	M50x1.5	4L	40
(IE1-)K20R 225 M2	FF 500	440	324	233	55	55	M20	110	110	16	16	59	59	225	177	832	947	100	A	213	207	M50x1.5	8L	45
(IE1-)K20R 225 M4, 6, 8	FF 500	440	324	233	65	55	M20	140	110	18	16	69	59	225	177	862	977	100	A	213	207	M50x1.5	8L	45
(IE1-)K20R 250 S2	FF 500	490	386	263	65	65	M20	140	140	18	18	69	69	250	206	924	1072	200	A	282	242	M63x1.5	8L	50
(IE1-)K20R 250 S4, 6, 8	FF 500	490	386	263	75	65	M20	140	140	20	18	79.5	69	250	206	924	1072	200	A	282	242	M63x1.5	8L	50
(IE1-)K20R 250 M2	FF 500	490	386	263	65	65	M20	140	140	18	18	69	69	250	206	924	1072	200	A	282	242	M63x1.5	8L	50
(IE1-)K20R 250 M4, 6, 8	FF 500	490	386	263	75	65	M20	140	140	20	18	79.5	69	250	206	970	1118	200	A	282	242	M63x1.5	8L	50

⁷⁾ Centre holes to DIN 332-DS

Three-phase motors with squirrel-cage rotor for use in powered smoke and heat extraction systems to EN 12101-3
Energy-saving motor, efficiency class Standard Efficiency IE1

Transnorm version
 Surface cooling, type of cooling IC 411, degree of protection IP 55
 Size 280, 315

Type of construction IM B5 [IM 3001]
Type of construction IM V1 [IM 3011]

Flange dimensions, see page 8/23

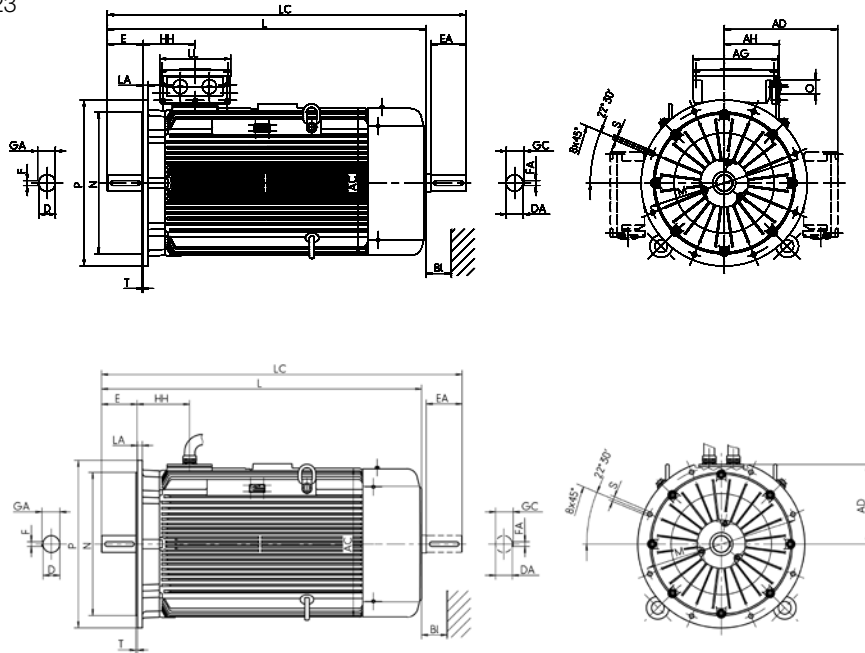

Type designation	Flange size	AC	AD	AD	D	DA	DB ¹⁾	E	EA	F	FA	GA	GC	H	HH	L	LC	TB Type	AG	LL	AH	O	BI
		g	g1	g1	d	d1		l	l1	u	u1	t	t1	h	A	k	k1		x	z	-	r	Bl
(IE1-)K20R 280 S2	FF 600	550	416	315	70	70	M20	140	140	20	20	74.5	74.5	280	211	1050	1218	200 A	282	242	-	M63 x 1.5	55
(IE1-)K20R 280 S4, 6, 8	FF 600	550	416	315	80	70	M20	170	140	22	20	85	74.5	280	211	1080	1248	200 A	282	242	-	M63 x 1.5	55
(IE1-)K20R 280 M2	FF 600	550	416	315	70	70	M20	140	140	20	20	74.5	74.5	280	211	1105	1273	200 A	282	242	-	M63 x 1.5	55
(IE1-)K20R 280 M4, 6, 8	FF 600	550	416	315	80	70	M20	170	140	22	20	85	74.5	280	211	1135	1303	200 A	282	242	-	M63 x 1.5	55
(IE1-)K20R 315 S2	FF 600	550	416	315	75	70	M20	140	140	20	20	79.5	74.5	315	211	1185	1353	200 A	282	242	-	M63 x 1.5	55
(IE1-)K20R 315 S4	FF 600	550	416	315	90	70	M24	170	140	25	20	95	74.5	315	211	1215	1383	200 A	282	242	-	M63 x 1.5	55
(IE1-)K20R 315 S6, 8	FF 600	550	416	315	90	70	M24	170	140	25	20	95	74.5	315	211	1135	1303	200 A	282	242	-	M63 x 1.5	55
(IE1-)K20R 315 M2	FF 600	610	498	348	75	75	M20	140	140	20	20	79.5	79.5	315	230	1270	1448	400 B	315	294	265	M63 x 1.5	55
(IE1-)K20R 315 M4, 6, 8	FF 600	610	498	348	90	75	M24	170	140	25	20	95	79.5	315	230	1300	1478	400 B	315	294	265	M63 x 1.5	55
(IE1-)K20R 315 M10, 12	FF 600	550	498	315	90	75	M24	170	140	25	20	95	79.5	315	211	1135	1303	400 B	315	294	265	M63 x 1.5	55
(IE1-)K20R 315 L2	FF 600	610	498	348	75	75	M20	140	140	20	20	79.5	79.5	315	230	1390	1568	400 B	315	294	265	M63 x 1.5	55
(IE1-)K20R 315 L4, 6, 8	FF 600	610	498	348	90	75	M24	170	140	25	20	95	79.5	315	230	1420	1598	400 B	315	294	265	M63 x 1.5	55
(IE1-)K20R 315 LX2	FF 600	610	481	348	75	75	M20	140	140	20	20	79.5	79.5	315	230	1510	1688	400 B	315	294	265	M63 x 1.5	55
(IE1-)K20R 315 LX4	FF 600	610	481	348	90	75	M24	170	140	25	20	95	79.5	315	230	1540	1718	400 B	315	294	265	M63 x 1.5	55
(IE1-)K20R 315 LX6, 8	FF 600	610	498	348	90	75	M24	170	140	25	20	95	79.5	315	230	1420	1598	400 B	315	294	265	M63 x 1.5	55

¹⁾ Centre holes to DIN 332-DS



Contents

Product description _____ 9/2

Light-duty version for converter-fed operation, self-ventilated, Type of cooling IC 411

Overview of technical data _____ 9/7

Motor selection data

Series IE3-A41R, duty types S1, S7/S9 _____ 9/8

Series IE2-AE.R, duty types S1, S7/S9 _____ 9/14

Bearings, terminal boxes and dimensions are identical to standard motors IE3-W41R und IE2-WE.R please refer chapter 2

Light-duty version for converter-fed operation, self-ventilated, Type of cooling IC 410

Overview of technical data _____ 9/20

Motor selection data

Series A..O _____ 9/21

Bearings und terminal boxes are identical to standard motors K21R please refer chapter 2

Dimensions _____ 9/23

heavy-duty version for converter-fed operation, non-ventilated, Type of cooling IC 410

Overview of technical data _____ 9/44

Motor selection data

Series ARC, duty types S7/S9 _____ 9/45

Bearings _____ 9/55

Limit speeds _____ 9/55

Terminal boxes _____ 9/56

Dimensions _____ 9/57

heavy-duty version for mains operation, non-ventilated, Type of cooling IC 410

Overview of technical data _____ 9/61

Motor selection data

Series ARB, duty types S4/S5 _____ 9/62

Please refer to bearings and terminal boxes series ARC

Dimensions _____ 9/63

Welded steel, transnorm,

Type of cooling IC 410, 411, 416, 71W (31W)

Overview of technical data _____ 9/65

Motor selection data

Series DS.. _____ 9/66

Bearings, terminal boxes and dimensions upon request

Product description

VEM is an innovative, dependable and internationally recognised manufacturer of technically sophisticated systems and drive solutions, as well as special drives and individual components. The product range covers practically the complete spectrum of electric motors and drives for industrial use. Through many years of experience in three-phase drive design, manufacturing, assembly and project development, VEM has gathered a wealth of know-how in many

specialised fields of application. One of these fields is the steel and rolling mill industry, with its extremely challenging demands and operating conditions. VEM has developed a full, complex package of drive solutions tailored to the specific requirements of this sector. This package includes not only “classic” roller table motors, but also geared roller table motors in numerous versions and “special motors” for particular applications in the rolling mill industry.

Series	Light-duty VEM roller table motors				Heavy-duty VEM roller table motors		
	(IE*-)A..R	(IE*-)A..F	(IE*-)A..O	(IE*-)A..B	ARB	ARC	DS..
Type of cooling	IC 411 Self-ventilated	IC 416 Forced-ventilated	IC 410 Non-ventilated	IC 31 W Water-cooled	IC 410 Non-ventilated	IC 410 Non-ventilated	IC 410, IC 411, IC 416, 31 W –
Power supply	Mains or converter-fed				Mains	Converter-fed	Mains or converter-fed
Efficiency class to IEC/EN 60034-30	132 ... 400	63 ... 400	225 ... 280	280 ... 400	22, 33, 54, 65	112 ... 400	355 ... 630
	without, IE1, IE2 or IE3				without	without	without
Output range [kW]	2.2 ... 710	0.06 ... 235	37 ... 90	110 ... 710	0.4 ... 5.5	1.1 ... 290	100 ... 1500
Duty types	S1, S3, S6, S7, S9				S4	S3, S6, S7, S9	S1, S3, S6, S7, S9
Rated torque [Nm]	24 ... 4550	0.3 ... 1515	240 ... 600	700 ... 4550	2.5 ... 35	10 ... 2500	1000 ... 15000
Acceleration torque [Nm]	55 ... 7000	0.5 ... 2700	490 ... 1000	1260 ... 8200	22 ... 240	45 ... 7500	1000 ... 25000
Housing material	EN-GJL-200, optionally EN-GJS 500			Sheet steel	EN-GJL-200	EN-GJL-200 optionally EN-GJS 500	Sheet steel
Housing type	Ribbed (horizontal/vertical)		Smooth surface		Ring-ribbed		Smooth surface/ ribbed
Thermal class	Thermal class 155, optionally 155 (F(B)), 180						
Transponder	Optional RFID system iID®2000 (13.56 MHz based on ISO 15693), (size A42. 400 as standard)						

*IE-class to IEC/EN 60034-30-1

Light-duty roller table motors, series IE3-A4../IE2-AE../A210/A200 for mains and converter-fed operation

Output range	0.09–approx. 710 kW
Degree of protection	IP 55 to IEC/EN 60034-5, higher degree of protection as an option
Types of cooling	IC 410, IC 411, IC 416 and water-jacket cooling IC 71 W (31 W) (upon request) to IEC/EN 60034-6
Types of construction	IM B3, IM B35, IM B5 and derived types to IEC/EN 60034-7

The series are derived from the VEM standard motor series and are mechanically identical in their principle design elements. The motor windings have been adapted to the

particular application of roller table drive. All screwed connections are additionally secured and the corrosion protection is similarly adapted for use in rolling mills.

Heavy-duty roller table motors, series ARC for converter-fed operation

Sizes	112–400
Output range	0.4–approx. 240 kW
Degree of protection	IP 55 to IEC/EN 60034-5, higher degree of protection as an option
Types of cooling	IC 410, IC 411, IC 416 to IEC/EN 60034-6
Types of construction	IM B3, IM B35, IM B5 and derived types to IEC/EN 60034-7

The series ARC (IC 410) is designed for converter-fed operation in rolling mill applications. It represents a combination of the positive features of a converter-fed double squirrel-cage rotor, with its torque characteristic geared to optimum acceleration (M_K/M_B approx. 3), and the mecha-

nically robust construction of a heavy-duty roller table motor. The overall design is identical to that of a VEM standard motor, with the exception of the housing form (circumferential ribs) and the bearing/seal arrangement on the D-end.

Heavy-duty roller table motors, series ARB for mains operation

Sizes	22 (132), 33 (125), 54 (180), 65 (200)
Output range	0.4–5.5 kW
Degree of protection	IP 55 to IEC/EN 60034-5, higher degree of protection as an option
Type of cooling	IC 410 to IEC/EN 60034-6
Types of construction	IM B3, IM B35, IM B5 and derived types to IEC/EN 60034-7

The heavy-duty roller table motor ARB (IC 410) is designed for mains operation. As with the ARC series, the housing is provided with circumferential cooling ribs. It is manufac-

ured from grey-cast iron with ribs running transverse to the shaft direction. The conventional motor design achieves a soft torque characteristic and long blocking times.

Transnorm motors, series DS, DSf, DSo, DSWM for mains and converter-fed operation

Sizes	355–630
Output range	100–approx. 1400 kW
Degree of protection	IP 55 to IEC/EN 60034-5, higher degree of protection as an option
Types of cooling	IC 410, IC 411, IC 416 and water-jacket cooling IC 71 W (31 W) to IEC/EN 60034-6
Types of construction	IM B3, IM B35, IM B5 and derived types to IEC/EN 60034-7

The motors are designed as welded steel constructions and can be adapted to specific project demands.

Robust to meet the toughest demands

The drive elements of the mill and driving tables in rolling mills are subjected to particularly exacting electrical and mechanical demands. They must cope with a diversity of operating modes, such as continuous, intermittent and short-time duty, as well as start-up, braking and reversing functions. Furthermore, the motors must withstand the high ambient temperatures arising from the molten steel and the overloads which may occur if jammed stock blocks the transport system. Exposure to water must frequently be expected, and this must be taken into account by the mechanical design of the motor. VEM roller table motors are ideally prepared to handle all such extreme operating conditions.



Wide hot strip mill train, ARC 315

Proven quality – modern design

VEM roller table motors of the classic series ARB 22–65 have been demonstrating their function capabilities and reliability under often extreme ambient conditions for many decades.

On the basis of this experience, VEM has developed several variants of roller table motors, which are each adapted to the special requirements of modern drive technologies for use in conjunction with a frequency converter. The motor windings are designed specifically for converter-fed operation. In contrast to a classic roller table motor design with soft torque characteristic and long blocking times, roller table motors for converter-fed operation feature a specially tailored characteristic, as is typical for a double squirrel-cage rotor. This ensures reliable synchronous operation with grouped drives, even under changing loads, which is turn a prerequisite for high rolling quality.



Motor of the ARB series for mains operation



Motor of the ARC series with built-on holding brake and incremental encoder

Versatile applications – individual adaptation

With regard to their mechanical design, the motors are available either as robust grey-cast constructions with horizontal/vertical ribbing, in versions with self- or forced ventilation as series IE2-AE.R/AE.F or in a non-ventilated version as series IE2-AE1O, or else on the basis of a ring-ribbed housing in the case of series ARC and ARB. In converter-fed operation, the operating speeds can be matched perfectly to the individual drive requirements. As control is realised primarily in the lower frequency range, project-specific adaptation of the windings and the use of a frequency converter with automatic voltage boost or field-oriented control are recommended. The windings are designed specifically for converter-fed operation. Detailed operating data sheets are available to assist project planning. They are based on windings for thermal class 155. Designs for thermal class 180 are also possible as an option, for example as a means to increase the frequency of switching operations. For existing installations, it is still possible to choose the heavy-duty series ARB, which is designed specifically for mains operation and can withstand a blocking period of several minutes without damage (soft torque characteristic, additional heat sinks on the rotor).



Furnace table with ARG 200L 12, $M_{max}=1888 \text{ Nm}$

Geared roller table motor version

The single- and multi-stage gearing arrangements used by VEM motors GmbH are developed in cooperation with leading gear manufacturers and designed specifically for operation in continuous casting, furnace and rolling mill plant. All individual components meet the tough demands posed by such environments. The gear housings are manufactured as grey cast iron (GG), spheroidal cast iron (GGG) or welded steel constructions, depending on the motor type and version. The dimensioning of the wall thickness ensures that ample space is available for the bearings and seals required at a particular place of installation. The actual gears are likewise matched in their dimensions to the individual demands. The gear teeth are designed as corrected involute helical teeth and have been case-hardened and honed. The quality complies with the stipulations of DIN quality class 7. The material used is 16MnCr5, 20MnCr5 or 17CrNiMo6. The drive shaft is sealed to the outside with a VITON sealing ring running on a hardened and ground bushing and with an additional labyrinth seal in order to prevent the penetration of dust, scale or water. The gearing is oil-lubricated (immersion lubrication). For special applications, for example in continuous casting plant (high ambient temperatures), we recommend lubrication with synthetic oils. In certain cases, fluid grease may be sufficient. The torques specified in the data sheet are firstly the nominal torque and secondly the acceleration or breakdown torque. The breakdown torque generally lies 20–30 % above the acceleration torque. The nominal torque can be delivered 24 hours a day without influencing service life. The acceleration torque can occur for a duration of 5 seconds approx. 100 times per hour without influencing the service life of the gearing. The maximum loading of the gears is designed such that the acceleration torque can be exceeded by 2.5 times occasionally (also several times per day, but not more than 10 times per hour for 2 seconds in each case), without influencing the service life of the gearing. The gearing is durable at acceleration torque. The motors are integrated with the gearing by way of at least four bolts. They can thus be separated from the gearing at any time, for example for maintenance purposes. It is



Roller table version, SG200 ARG 200L 8, $M_{max}= 1655 \text{ Nm}$



Delay table with S141-1A ARG 160L 4, $M_{max}=1039 \text{ Nm}$

merely necessary to drain the oil from the gearing before separation. The motors always possess an oil-tight seal at the drive end. The bearing on the non-drive end is generally provided with lifetime lubrication.

VEM – your competent partner for drive questions

Wherever our customers need electric machines, we are at hand as a partner and offer every necessary support at all phases of a project. It is not important whether you are doing business in Europe, the Middle East, Asia or America. As the VEM market share increases beyond Germany, we are also expanding our sales network with a combination of own subsidiary companies and strategic alliances.

Already today, our customers can address their questions to competent and experienced local partners all over the world. Our dense sales and service network comprises VEM subsidiaries in Finland, Great Britain, Norway, Austria, Sweden and Singapore, alongside agents and representatives in more than 40 countries.

Design versions

The housings of the light-duty series IE3-A4../IE2-AE../A2.O possess horizontal/vertical ribbing, whilst on the heavy-duty series ARB/ARC the cooling ribs run transverse to the shaft direction. Both housing designs are characterised by their high mechanical strength and very good thermal capacity.

The terminal box for motors of the series AE.O can be mounted either at the top, on the right or on the left, as is the case for the standard motor series K21R, K20R. The terminal box for series ARB is mounted on the right, while that for series ARC is positioned either on the top at the non-drive end or optionally on the non-drive-end shield.

Shaft height	Series	Housing	Material for			Foot mounting
			End shields	Feet		
132 to 280	IE3-A4../ IE2-AE../ A2.O	Grey cast iron	Grey cast iron	Grey cast iron	Bolted	
315					Cast	
355, 400					Cast	
112 to 400	ARC				Cast	
22 to 65	ARB				Cast	
355 to 630	DSWM	Steel	Steel	Steel	Welded	

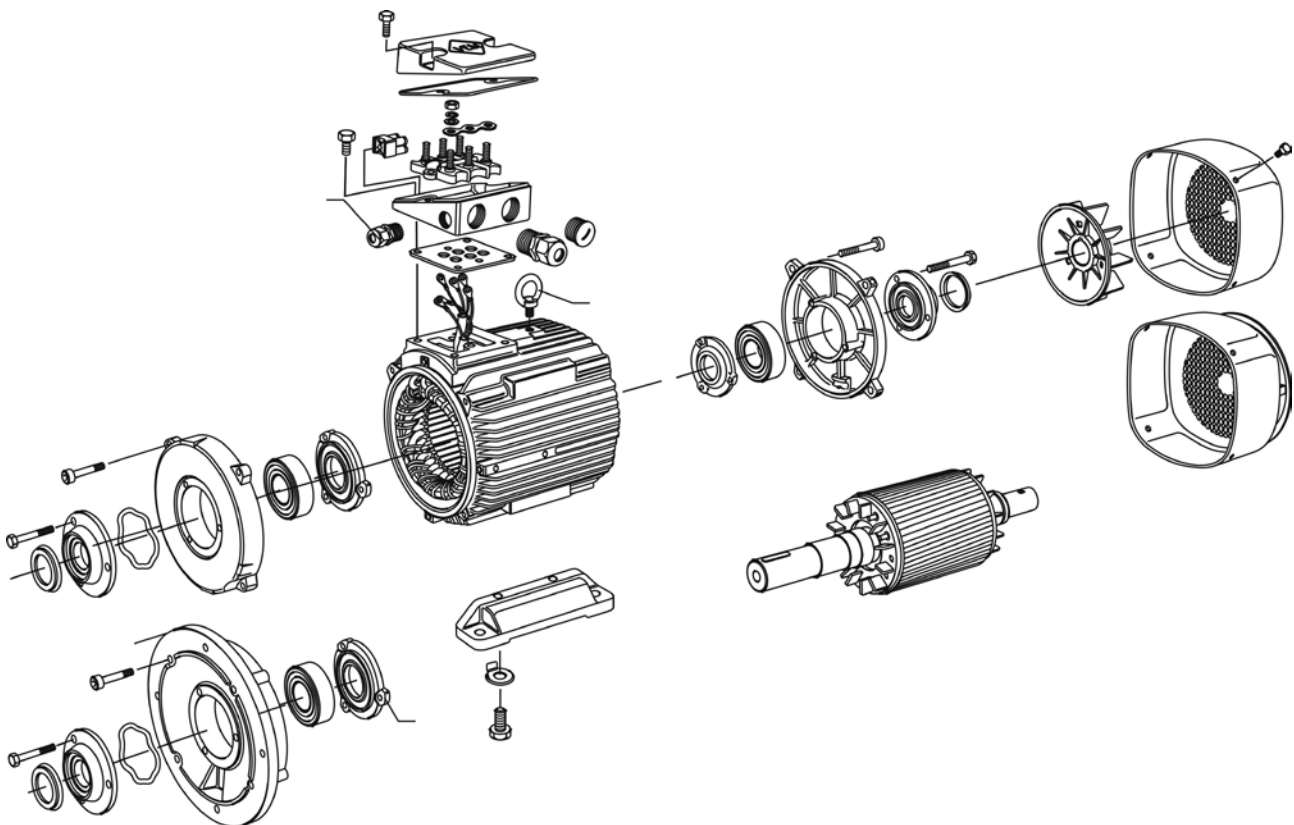

Design of an IE2-AE.R motor, schematic representation

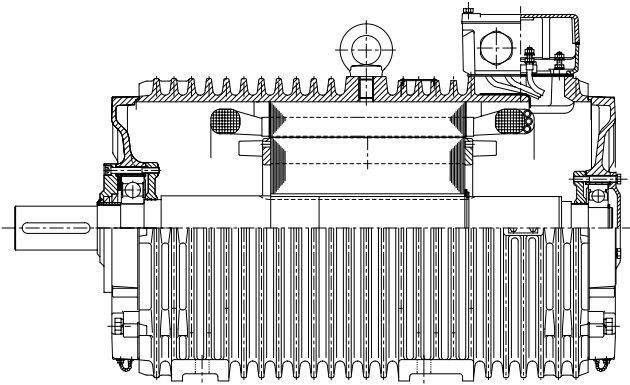

Design example for series ARC, with top-mounted terminal box

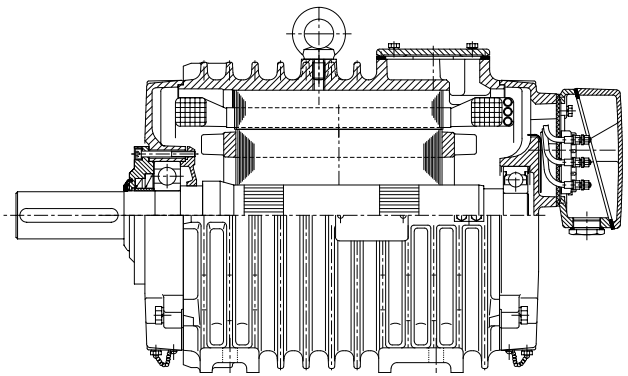

Design example for series ARC, terminal box on non-drive-end shield

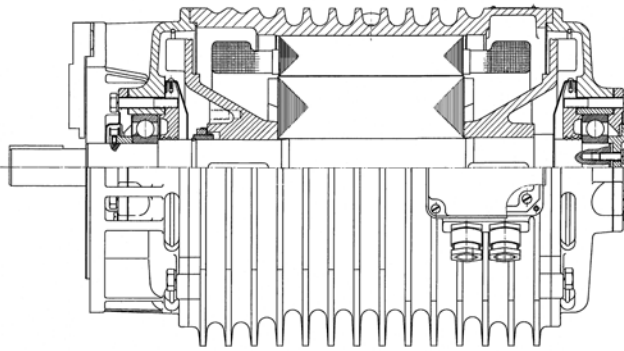

Design example for series ARB, terminal box mounted on the right

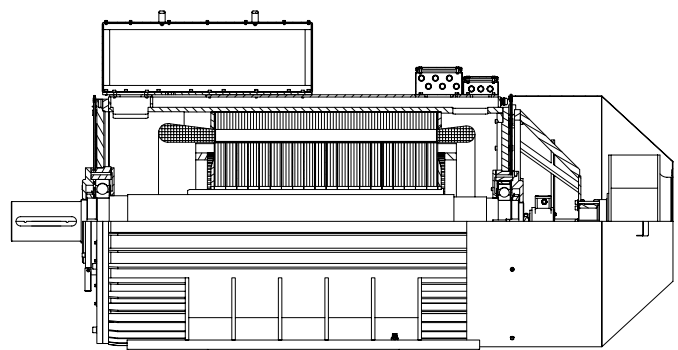
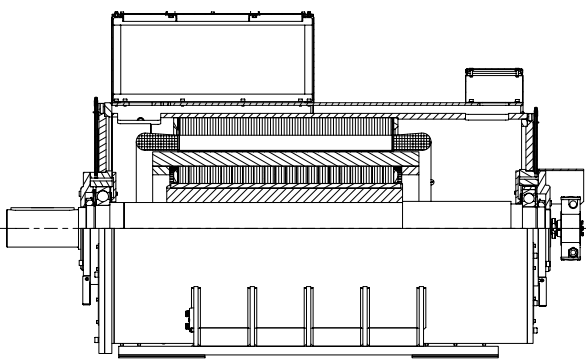

Design examples for welded-steel transnorm motors, types of cooling IC 411 and IC 416

Overview of technical data

Three-phase roller table motors with squirrel-cage rotor, light-duty version for converter-fed operation, self-ventilated, Type of cooling IC 411

The most important technical data are summarised in the following table. Further information can be taken from the catalogue section "Introduction" (chapter 1).

Product group	Roller table motors, squirrel-cage rotor, IEC/EN
Rated output	5.5 kW to 500 kW (IE2-, IE3-model 2-, 4-, 6- und 8-pole)
Sizes	132 to 355
Housing material	Grey cast iron EN GJL-200 to DIN EN 1561 or optionally spheroidal cast iron EN-GJS 500 to DIN EN 1563 with horizontal/vertical cooling ribs
Rated torque	24 Nm to 3400 Nm
Efficiency classification/ efficiency determination	IEC/EN 60034-30-1 / IEC/EN 60034-2-1, ≤ 1 kW direct measurement, > 1 kW residual loss method
Duty types	S1, S7/S9 to IEC/EN 60034-1
Method of connection	Single-speed motors are designed in star-delta configuration as standard. In the case of pole-changing motors, the method of connection is dependent on the combination of pole numbers, see selection lists.
Stator winding insulation	Thermal class 155, optionally 155 [F(B)], 180 to IEC/EN 60034-1
Degree of protection	IP 55 to IEC/EN 60034-5, optionally IP 56 and higher
Type of cooling	IC 411, optionally IC 410, IC 416 to IEC/EN 60034-6
Coolant temperature/ installation altitude	Standard -20 °C to +40 °C, Altitude 1000 m above sea level
Rated voltage	Standard voltages to EN 60038 50 Hz: 230 V, 400 V, 500 V, 690 V 60 Hz: 275 V, 460 V, 480 V, 600 V Rated Voltage ranges A and B to IEC/EN 60034-1
Types of construction	IM B3, IM B35, IM B5 and derived types to IEC/EN 60034-7
Paint finish	Normal finish "Moderate", colour RAL 7031, blue-grey Special finish "Worldwide", colour RAL 7031, blue-grey
Vibration severity grade	Grade "A" as standard for machines with no special vibration requirements
Shaft ends	to DIN 748 (IEC 60072), Balanced with half-key
Sound pressure level	to DIN EN ISO 1680, tolerance + 3 dB,
Limit speeds	Please refer to the section of "Limit speeds" in catalogue section "Motors for converter-fed operation", Chapter 4.
Bearing design	Please refer to the tables of "Bearing design data" in catalogue section „Standard motors“, Chapter 2.
Motor mass	Please refer to the technical selection lists.
Terminal boxes	Please refer to the section "Terminal boxes" in catalogue section „Standard motors“, Chapter 2.
Documentation	An operating and maintenance manual, a terminal plan and a safety data sheet are supplied with each motor.
Tolerances	Please refer to the section "Tolerances" in catalogue section "Introduction", Chapter 1.
Options	Please refer to the section "Overview of modifications" in catalogue section "Introduction", Chapter 1.

Motor selection data

Three-phase roller table motors with squirrel-cage rotor, Premium Efficiency IE3 light-duty version for converter-fed operation

self-ventilated, type of cooling IC 411, duty type S1, S7/S9
for rated voltage, thermal class 155 (F), degree of protection IP 55, 50 Hz

Motor selection data																	Design point 400 V, 50 Hz/460 V, 60 Hz			
Type	Converter input voltage to	U _B	f _B	P _B	M _B	P _B	M _B	n _B	η _B			cosφ _B	I _B	I _K /I _B	M _K /M _B	M _S /M _B	M _K /M _B	J	m	
	420 V	500 V	V	Hz	kW	Nm	kW	Nm	rpm	(IEC/EN 60034-2-1)			-	A	-	-	-	kgm ²	kg	
Synchronous speed 3000 rpm – 2-pole version																				
IE3-A41R 132 SX2	IE3-AU1R 132 SX2	400	50	7.5	24.0	7.5	24.0	2925	IE3-	90.1	89.4	87.9	0.87	14.0	8.0	2.5	2.1	3.3	0.0168	75
		460	60	9	24	9	24	3520	IE3-	90.5	89.5	87.8	0.89	14	7.1	2.3	1.9	3.1		
IE3-A41R 160 M2	IE3-AU1R 160 M2	400	50	11	36.0	11	36.0	2950	IE3-	91.4	91.7	90.5	0.90	19.5	8.0	2.2	1.8	3.2	0.0575	125
		460	60	13.2	36	13.2	36	3540	IE3-	91	90	87.9	0.91	20	7.3	2	1.6	2		
IE3-A41R 160 MX2	IE3-AU1R 160 MX2	400	50	15	49.0	15	49.0	2950	IE3-	91.9	92.0	91.3	0.91	26.0	7.9	2.2	1.7	3.1	0.0675	145
		460	60	18	48	18	48	3545	IE3-	92	92.3	91.2	0.92	26.5	7.4	2	1.6	2.9		
IE3-A41R 160 L2	IE3-AU1R 160 L2	400	50	18.5	60.0	18.5	60.0	2960	IE3-	92.4	92.5	91.4	0.90	32.0	9.2	2.6	2.1	3.6	0.078	160
		460	60	22	59	22	59	3550	IE3-	92	91.9	90.7	0.91	33	8.5	2.4	1.9	3.3		
IE3-A41R 180 M2C	IE3-AU1R 180 M2C	400	50	22	71	22	71	2975	IE3-	92.7	92.6	91.5	0.91	37.5	8.9	1.9	1.4	3.3	0.1717	214
		460	60	26	70	26	70	3570	IE3-	92.4	92.0	90.7	0.92	38.5	8.2	1.8	1.3	3.0		
IE3-A41R 200 L2	IE3-AU1R 200 L2	400	50	30	97	30	97	2965	IE3-	93.3	92.2	90.6	0.88	52.5	8.6	2.1	1.6	3.3	0.36	305
		460	60	33	88	33	88	3565	IE3-	92.4	91.0	88.6	0.88	51.0	8.5	2.1	1.6	3.2		
IE3-A41R 200 LX2C	IE3-AU1R 200 LX2C	400	50	37	119	37	119	2980	IE3-	93.7	92.9	91.7	0.89	64.0	8.7	1.7	1.3	3.2	0.4757	310
		460	60	40	107	40	107	3575	IE3-	93	91.7	89.5	0.89	60.5	8.8	1.8	1.3	3.2		
IE3-A41R 225 M2	IE3-AU1R 225 M2	400	50	45	145	45	145	2960	IE3-	94.0	93.7	93.0	0.89	77.5	8.8	2.3	1.9	3.2	0.375	375
		460	60	54	145	54	145	3553	IE3-	93.6	93.3	92.6	0.89	81.5	8.1	2.1	1.7	2.9		
IE3-A41R 250 M2	IE3-AU1R 250 M2	400	50	55	177	55	177	2970	IE3-	94.6	94.4	93.6	0.91	92	8.9	2.2	1.9	3.2	0.65	510
		460	60	66	177	66	177	3568	IE3-	94.1	93.5	92.3	0.92	95.5	8.2	2	1.8	2.9		
IE3-A41R 280 S2	IE3-AU1R 280 S2	400	50	75	241	75	241	2967	IE3-	94.7	94.5	93.9	0.89	128	8.1	1.9	1.9	2.8	0.65	500
		460	60	82	220	82	220	3566	IE3-	94.5	94	92.5	0.90	121	8.1	2	1.8	3		
IE3-A41R 280 M2	IE3-AU1R 280 M2	400	50	85	273	90	289	2970	IE3-	95	94.5	94	0.90	152	8.4	2.2		3.1	0.675	545
		460	60	85		90							upon request							
IE3-A41R 315 S2	IE3-AU1R 315 S2	400	50	110	354	110	354	2970	IE3-	95.2	94.5	93.5	0.89	187	10.0	1.9	1.7	3.0	1.21	750
		460	60	110	294	110	294	3570	IE3-	95.0	94.0	92.5	0.89	163	10	2	1.8	3.2		
IE3-A41R 315 M2	IE3-AU1R 315 M2	400	50	132	423	132	423	2980	IE3-	95.4	95.0	94.5	0.89	224	10.0	2.0	1.8	3.0	1.44	815
		460	60	145	387	145	387	3580	IE3-	95.4	95.0	94.5	0.89	214	10	2	1.8	3		
IE3-A41R 315 MX2	IE3-AU1R 315 MX2	400	50	160	513	160	513	2980	IE3-	95.7	95.7	95.0	0.9	268	8.5	2.3	1.7	2.6	2.37	1095
		460	60	165	440	165	440	3585	IE3-	95.4	95	94	0.89	244	9	2.5	1.8	2.8		
IE3-A41R 315 MY2	IE3-AU1R 315 MY2	400	50	192	615	200	641	2980	IE3-	95.8	95.9	95.5	0.91	331	8.3	2.6	1.6	2.4	2.82	1200
		460	60	211	563	220	587	3580	IE3-	95.8	95.3	94.5	0.91	317	8.5	2.8	1.7	2.7		
IE3-A41R 315 L2	IE3-AU1R 315 L2	400	50	220	704	250	800	2985	IE3-	96.0	96.0	95.9	0.92	409	8.4	2.5	1.4	2.3	3.66	1460
		460	60	246	656	280	747	3580	IE3-	96	96	95.5	0.92	458	8.2	2.5	1.4	2.3		
IE3-A41R 315 LX2	IE3-AU1R 315 LX2	400	50	270	864	315	1008	2985	IE3-	95.8	95.8	95.8	0.92	516	8.5	2.8	1.6	2.5	4.43	1700
		460	60	291	775	340	906	3585	IE3-	95.8	95.8	95.5	0.92	484	9.1	2.9	1.6	2.5		
IE3-A41R 355 M2	IE3-AU1R 355 M2	400	50	330	1056	355	1136	2985	IE3-	96.0	96.0	96.0	0.92	580	7.7	1.9	1.5	3.8	4.20	2000
IE3-A42R 355 MX2	IE3-AU2R 355 MX2	400	50	355	1135	400	1278	2988	IE3-	96.0	96.0	96.0	0.92	654	8.5	1.8	1.1	2.5	5.50	2275
IE3-A42R 355 L2	IE3-AU2R 355 L2	400	50	370	1182	500	1597	2990	IE3-	96.2	96.2	96.2	0.90	834	11.0	2.2	1.4	3.2	7.10	2445
IE3-A42R 400 M2	IE3-AU2R 400 M2	400	50	450	1435	560	1786	2995	IE3-	96.0	96.0	95.5	0.83	1014	9.0	2.8		3.0	8.44	3000
IE3-A42R 400 MX2	IE3-AU2R 400 MX2	400	50	500	1596	630	2011	2992	IE3-	96.0	96.0	95.5	0.91	1041	9.5	2.5		2.7	9.41	3200
IE3-A42R 400 L2	IE3-AU2R 400 L2	400	50	580	1856	710	2272	2985	IE3-	96.0	96.0	95.5	0.90	1186	7.7	2.2	1.1	2.8	10.41	3450

Three-phase roller table motors with squirrel-cage rotor, Premium Efficiency IE3 light-duty version for converter-fed operation

self-ventilated, type of cooling IC 411, duty type S1, S7/S9
for rated voltage, thermal class 155 (F), degree of protection IP 55, 50 Hz

Motor selection data															Design point 400 V, 50 Hz/460 V, 60 Hz					
Type	Converter input voltage to		U _B V	f _B Hz	P _B M _B Converter		P _B M _B Mains		n _B rpm	η _B (IEC/EN 60034-2-1)			cosφ _B	I _B A	I _A /I _B	M _A /M _B	M _S /M _B	M _K /M _B	J kgm ²	m kg
	420 V	500 V			P _B kW	M _B Nm	P _B kW	M _B Nm		100 %	75 %	50 %								
Synchronous speed 1500 rpm – 4-pole version																				
IE3-A41R 132 S4	IE3-AU1R 132 S4	400	50	5.5	35	5.5	35	1480	IE3-	91.0	90.2	87.8	0.73	12.0	9.9	3.4	2.8	5.4	0.035	90
		460	60	6.6	35	6.6	35	1780	IE3-	91.8	91	88.9	0.77	11.7	9.6	3.1	2.6	5		
IE3-A41R 132 M4	IE3-AU1R 132 M4	400	50	7.5	49	7.5	49	1475	IE3-	91.3	91.3	90.1	0.83	14.5	8.6	2.4	2.0	3.9	0.043	100
		460	60	9	49	9	49	1765	IE3-	91.8	91.7	90.6	0.85	14.5	8	2.3	1.9	3.6		
IE3-A41R 160 M4	IE3-AU1R 160 M4	400	50	11	71	11	71	1475	IE3-	91.4	91.5	90.5	0.83	21.0	7.5	2.5	2.0	3.2	0.078	125
		460	60	12.5	67	12.5	67	1775	IE3-	92.4	91.8	90.6	0.80	21.5	7.4	2.4	2	3.1		
IE3-A41R 160 L4C	IE3-AU1R 160 L4C	400	50	15	96	15	96	1490	IE3-	92.8	92.5	91.0	0.83	28.0	10.5	2.8	2.4	3.9	0.1567	175
		460	60	18	96	18	96	1785	IE3-	93.6	92.8	91.3	0.85	28.5	9.9	2.6	2.2	3.6		
IE3-A41R 180 M4	IE3-AU1R 180 M4	400	50	18.5	120	18.5	120	1475	IE3-	92.7	92.9	92.0	0.84	34.5	6.9	1.9	1.7	3.0	0.168	210
		460	60	22	118	22	118	1775	IE3-	93.6	93.0	92.3	0.84	35.0	6.5	1.8	1.9	2.8		
IE3-A41R 180 L4	IE3-AU1R 180 L4	400	50	22	142	22	142	1480	IE3-	93.0	93.0	92.1	0.84	40.5	7.6	2.2	2.0	3.2	0.203	240
		460	60	25	134	25	134	1775	IE3-	93.6	92.8	91.8	0.85	39.5	7.5	2.1	1.9	3.1		
IE3-A41R 200 L4C	IE3-AU1R 200 L4C	400	50	30	193	30	193	1485	IE3-	93.6	92.4	92.4	0.85	54.5	7.0	1.6	1.4	2.6	0.411	327
		460	60	30	160	30	160	1790	IE3-	94.1	92.8	91.0	0.84	47.5	7.7	1.7	1.5	2.8		
IE3-A41R 225 S4C	IE3-AU1R 225 S4C	400	50	37	237	37	237	1490	IE3-	93.9	93.8	93.2	0.85	67.0	7.4	1.9	1.4	2.7	0.4675	367
		460	60	40	214	40	214	1785	IE3-	94.5	93.7	92.5	0.85	62.5	7.5	1.9	1.4	2.7		
IE3-A41R 225 M4	IE3-AU1R 225 M4	400	50	45	290	45	290	1482	IE3-	94.2	94.3	94.0	0.82	84	8.1	2.6	2.1	2.6	0.619	450
		460	60	49	263	49	263	1782	IE3-	95	94	91.5	0.83	79	8.7	2.7	2.2	2.7		
IE3-A41R 250 M4	IE3-AU1R 250 M4	400	50	55	354	55	354	1485	IE3-	94.7	94.8	94.4	0.83	101	8.1	2.1	1.8	2.5	0.95	550
		460	60	55	294	55	294	1785	IE3-	95.4	94.9	93.5	0.83	87	8.9	2.3	2	2.7		
IE3-A41R 280 S4	IE3-AU1R 280 S4	400	50	75	482	75	482	1485	IE3-	95.0	94.6	94.2	0.83	137	8.2	2.1	1.8	2.5	1.1	617
		460	60	90	482	90	482	1783	IE3-	95.4	94.6	94	0.84	141	7.9	2	1.7	2.3		
IE3-A41R 280 M4	IE3-AU1R 280 M4	400	50	90	578	90	578	1487	IE3-	95.2	94.7	94.0	0.83	164	9.2	2.1	1.9	2.7	1.96	785
		460	60	90	480	90	480	1790	IE3-	95	95.4	93.2	0.82	144	10	2	1.9	2.9		
IE3-A41R 315 S4	IE3-AU1R 315 S4	400	50	110	706	110	706	1487	IE3-	95.4	95.0	94.3	0.82	203	9.5	1.9	1.7	2.7	1.96	760
		460	60	125	668	125	668	1788	IE3-	95.8	95.2	94.3	0.83	197	9.2	2.1	2	2.7		
IE3-A41R 315 M4	IE3-AU1R 315 M4	400	50	132	849	132	849	1485	IE3-	95.6	95.4	95.0	0.83	240	9.0	2.2	1.9	2.7	2.27	850
		460	60	129	689	129	689	1787	IE3-	95.8	95.3	94.7	0.83	204	10	2.3	2.1	2.9		
IE3-A41R 315 MX4	IE3-AU1R 315 MX4	400	50			160	1029	1485	IE3-	95.8	95.0	94.5	0.83	290	8.5	1.5	1.6	2.5	2.73	975
		460	60			160							upon request							
IE3-A41R 315 MX4	IE3-AU1R 315 MX4	400	50	160	1026	160	1026	1490	IE3-	95.8	95.5	95.0	0.84	287	9.5	2.1	2.0	3.2	4.01	1120
		460	60	175	934	175	934	1790	IE3-	96.2	96	95	0.84	272	10	2.1	2	3.2		
IE3-A41R 315 MY4	IE3-AU1R 315 MY4	400	50	200	1282	200	1282	1490	IE3-	96.0	95.8	95.5	0.87	346	9.5	2.1	1.7	2.7	4.82	1250
		460	60	225	1200	225	1200	1790	IE3-	96.2	96	95.5	0.86	341	9.5	2.2	1.8	2.7		
IE3-A41R 315 L4	IE3-AU1R 315 L4	400	50	250	1602	250	1602	1490	IE3-	96.2	96.2	96.0	0.87	431	9.4	2.2	1.8	2.7	5.93	1450
		460	60	280	1494	280	1494	1790	IE3-	96.2	96.1	95.7	0.87	420	9.3	2.2	1.8	2.7		
IE3-A41R 315 LX4	IE3-AU1R 315 LX4	400	50	285	1827	315	2019	1490	IE3-	96.0	96.0	96.0	0.87	544	9.5	2.3	1.7	2.9	6.82	1630
		460	60	285	1521	315	1680	1790	IE3-	96.2	96.2	95.5	0.87	472	10.5	2.6	1.9	3.2		
IE3-A41R 355 M4	IE3-AU1R 355 M4	400	50	355	2271	355	2271	1493	IE3-	96.2	96.2	95.5	0.87	612	8.1	1.3	1.0	2.7	7.90	2150
		460	60	375	2001	375	2001	1790	IE3-	96.2	95.8	95	0.87	647	9.1	1.3	1	3.2		
IE3-A42R 355 MX4	IE3-AU2R 355 MX4	400	50	390	2500	400	2564	1490	IE3-	96.2	96.2	96.2	0.84	714	8.2	1.7	1.4	2.4	9.50	2410
IE3-A42R 355 L4	IE3-AU2R 355 L4	400	50	480	3077	500	3205	1490	IE3-	96.4	96.4	96.0	0.84	891	7.4	2.5	1.2	2.3	10.00	2500
IE3-A42R 400 M4	IE3-AU2R 400 M4	400	50	500	3198	560	3582	1493	IE3-	96.3	96.3	96.0	0.87	965	10.5	2.0		2.5	12.60	2900
IE3-A42R 400 MX4	IE3-AU2R 400 MX4	400	50	580	3707	630	4027	1494	IE3-	96.5	96.5	96.0	0.86	1096	10.0	3.1		3.3	14.33	3100
IE3-A42R 400 L4	IE3-AU2R 400 L4	400	50	650	4158	710	4542	1493	IE3-	96.5	96.5	96.5	0.86	1235	11.4	4.1		3.8	16.29	3400

**Three-phase roller table motors with squirrel-cage rotor, Premium Efficiency IE3
light-duty version for converter-fed operation**

self-ventilated, type of cooling IC 411, duty type S1, S7/S9
for rated voltage, thermal class 155 (F), degree of protection IP 55, 50 Hz

Motor selection data														Design point 400 V, 50 Hz/460 V, 60 Hz						
Type	Converter input voltage to		U _B V	f _B Hz	P _B M _B Converter		P _B M _B Mains		n _B rpm	η _B (IEC/EN 60034-2-1)			cosφ _B	I _B A	I _A /I _B	M _A /M _B	M _G /M _B	M _K /M _B	J kgm ²	m kg
	420 V	500 V			P _B kW	M _B Nm	P _B kW	M _B Nm		100 %	75 %	50 %								
Synchronous speed 1000 rpm – 6-pole version																				
IE3-A41R 132 M6	IE3-AU1R 132 M6	400	50	4	40	4	40.0	965	IE3-	86.8	87.0	86.0	0.80	8.3	4.8	1.7	1.4	2.4	0.043	75
		460	60	4.5	37	4.5	37	1170	IE3-	89.5	88.7	87.6	0.80	7.9	4.8	1.7	1.5	2.4		
IE3-A41R 132 MX6	IE3-AU1R 132 MX6	400	50	5.5	54	5.5	54.0	970	IE3-	88.6	88.6	87.2	0.80	11.0	6.0	2.1	1.7	3.0	0.053	105
		460	60	5.7	46	5.7	46	1175	IE3-	91	89.8	87.5	0.79	10	6.5	2.2	1.9	3.2		
IE3-A41R 160 M6	IE3-AU1R 160 M6	400	50	7.5	73	7.5	73.0	980	IE3-	90.2	90.0	88.3	0.83	14.5	6.4	2.4	2.0	3.0	0.145	145
		460	60	9	73	9	73	1175	IE3-	91.3	90.6	89	0.85	14.6	6	2.2	1.9	2.8		
IE3-A41R 160 L6C	IE3-AU1R 160 L6C	400	50	11	107	11	107.0	985	IE3-	91.4	91.2	89.8	0.85	20.5	6.8	2.2	2	2.8	0.166	168
		460	60	13	105	13	105	1185	IE3-	91.7	91.4	90	0.86	20.5	6.5	2.1	1.9	2.6		
IE3-A41R 180 L6C	IE3-AU1R 180 L6C	400	50	15	145	15	145.0	985	IE3-	91.2	91.3	90.2	0.87	27.5	6.8	2	1.7	2.7	0.3396	214
		460	60	18.5	149	18.5	149	1185	IE3-	93	91.9	90.5	0.85	29.5	6.2	1.8	1.5	2.5		
IE3-A41R 200 L6	IE3-AU1R 200 L6	400	50	18.5	180	18.5	180.0	980	IE3-	91.8	91.7	90.5	0.87	33.5	7.2	2.3	2	3	0.514	310
		460	60	22	178	22	178	1180	IE3-	93	91.7	90.5	0.87	34	6.7	2.1	1.8	2.8		
IE3-A41R 200 LX6C	IE3-AU1R 200 LX6C	400	50	22	213	22	213.0	985	IE3-	92.2	91.5	90	0.87	39.5	7.6	2.1	1.7	2.9	0.6476	321
		460	60	22	177	22	177	1190	IE3-	93	91.4	89.4	0.87	34	6.5	2.4	1.9	3.2		
IE3-A41R 225 M6	IE3-AU1R 225 M6	400	50	30	291	30	291	984	IE3-	92.9	92.2	91.0	0.84	55.5	7.2	2.7	2.2	2.9	0.92	400
		460	60	30	***	30							***							
IE3-A41R 250 M6	IE3-AU1R 250 M6	400	50	37	359	37	359	985	IE3-	93.3	93.2	92.3	0.86	66.5	7.1	2.8	2.0	2.7	1.48	545
		460	60	40	322	40	322	1185	IE3-	94.1	93.3	92	0.86	62	7.2	2.9	2	2.8		
IE3-A41R 280 S6	IE3-AU1R 280 S6	400	50	45	434	45	434	990	IE3-	93.7	93.5	91.5	0.86	80.5	8.5	2.1	1.8	2.8	2.63	695
		460	60	45	***	45							***							
IE3-A41R 280 M6	IE3-AU1R 280 M6	400	50	55	531	55	531	990	IE3-	94.2	94.1	93.1	0.85	99	9.0	2.2	1.9	3.1	3.33	815
		460	60	55	440	55	440	1195	IE3-	94.5	94	92.5	0.85	86	9.5	2.5	2.2	3.4		
IE3-A41R 315 S6	IE3-AU1R 315 S6	400	50			75	723	990	IE3-	94.6	94.0	93.5	0.87	132	7.8	2.0	1.6	2.5	3.6	910
		460	60			75							***							
IE3-A41R 315 S6	IE3-AU1R 315 S6	400	50	75	723	75	723	990	IE3-	94.6	94.0	93.5	0.86	133	8.2	1.8	1.4	2.3	5.55	1060
		460	60	85	***	85							***							
IE3-A41R 315 M6	IE3-AU1R 315 M6	400	50	90	868	90	868	990	IE3-	94.9	94.0	93.0	0.86	159	8.5	2.2	1.7	2.8	6	1100
		460	60	99	***	99														
IE3-A41R 315 MX6	IE3-AU1R 315 MX6	400	50	110	1061	110	1061	990	IE3-	95.1	95.0	94.5	0.86	194	8.5	2.5	1.7	2.7	6.67	1210
		460	60	120	***	120							***							
IE3-A41R 315 L6	IE3-AU1R 315 L6	400	50	132	1267	132	1267	995	IE3-	95.4	95.0	94.5	0.87	230	9.0	2.8	2.0	3.2	8.6	1550
		460	60	132	1055	132	1055	1195	IE3-	95.8	95.3	94.4	0.84	206	9.5	3	2.2	3.5		
IE3-A41R 355 M6	IE3-AU1R 355 M6	400	50	160	1536	160	1536	995	IE3-	95.6	95.0	94.6	0.82	295	8.0	2.1	0.0	2.7	8.2	1850
		460	60	175	***	175							***							
IE3-A41R 355 MX6	IE3-AU1R 355 MX6	400	50	200	1919	200	1919	995	IE3-	95.8	95.0	94.0	0.85	355	9.0	2.1	0.0	2.9	12.10	2200
		460	60	200	***	200							***							
IE3-A42R 355 MX6	IE3-AU2R 355 MX6	400	50	200	1919	200	1919	995	IE3-	95.8	95.5	95.0	0.84	359	9.6	2.2	1.7	2.8	12.10	2350
IE3-A42R 355 LY 6	IE3-AU2R 355 LY 6	400	50	250	2399	250	2399	995	IE3-	95.8	95.5	95.0	0.82	459	8.0	1.8	1.5	2.5	14.00	2450
IE3-A42R 355 L6	IE3-AU2R 355 L6	400	50	315	3023	315	3023	995	IE3-	95.8	96.0	95.7	0.84	565	7.8	2.0	1.5	2.2	14.00	2450
IE3-A42R 400 MY6	IE3-AU2R 400 MY6	400	50	355	3407	355	3407	995	IE3-	96.0	96	95.8	0.83	643	7.5	1.2	1.2	2.1	16.54	3000
IE3-A42R 400 M6	IE3-AU2R 400 M6	400	50	400	3839	400	3839	995	IE3-	96.2	96.2	96	0.83	723	8.0	1.5	1.3	2.5	16.54	3000
IE3-A42R 400 MX6	IE3-AU2R 400 MX6	400	50	450	4314	450	4314	996	IE3-	96.0	96	95.8	0.84	805	7.6	1.5		2.2	18.44	3100
IE3-A42R 400 L6	IE3-AU2R 400 L6	400	50	500	4794	500	4794	996	IE3-	96.4	96.4	96.4	0.82	1023	7.5	1.7		2.2	20.63	3320

***) upon request

Three-phase roller table motors with squirrel-cage rotor, Premium Efficiency IE3 light-duty version for converter-fed operation

self-ventilated, type of cooling IC 411, duty type S1, S7/S9
for rated voltage, thermal class 155 (F), degree of protection IP 55, 50 Hz

Motor selection data														Design point 400 V, 50 Hz/460 V, 60 Hz							
Type	Converter input voltage to		U _B V	f _B Hz	P _B M _B Converter		P _B M _B Mains		n _B rpm	η _B (IEC/EN 60034-2-1)			cos φ _B	I _B A	I _A /I _B	M _A /M _B	M _G /M _B	M _K /M _B	J kgm ²	m kg	
	420 V	500 V			kW	Nm	kW	Nm		100 %	75 %	50 %									
Synchronous speed 750 rpm – 8-pole version																					
IE3-A41R 132 S8	IE3-AU1R 132 S8		400	50	2.2	29	2.2	29	725	IE3-	84.4	84.5	82.4	0.7	5.4	4.1	1.6	1.5	2.3	0.043	80
IE3-A41R 132 M8	IE3-AU1R 132 M8		400	50	3	40	3	40	720	IE3-	83.5	83.5	81.4	0.72	7	3.9	1.6	1.4	2.1	0.043	74
IE3-A41R 160 M8	IE3-AU1R 160 M8		400	50	4	52	4	52	735	IE3-	87	86.7	83.8	0.71	9.4	5.4	2.5	2.2	2.9	0.113	119
IE3-A41R 160 MX8	IE3-AU1R 160 MX8		400	50	5.5	72	5.5	72	730	IE3-	87.5	87.5	85.6	0.73	12.5	4.7	1.9	1.7	2.5	0.145	143
IE3-A41R 160 L8	IE3-AU1R 160 L8		400	50	7.5	98	7.5	98	730	IE3-	87.9	87.6	85.6	0.73	17	5.1	2.1	1.8	2.7	0.166	155
IE3-A41R 180 L8	IE3-AU1R 180 L8		400	50	11	143	11	143	733	IE3-	89.3	89	87.1	0.75	23.5	5.4	2.1	1.9	2.8	0.228	175
IE3-A41R 200 L8	IE3-AU1R 200 L8		400	50	15	196	15	196	730	IE3-	89.6	90	89	0.80	30	5.3	1.8	1.7	2.5	0.324	235
IE3-A41R 225 S8	IE3-AU1R 225 S8		400	50	18.5	242	18.5	242	730	IE3-	90.1									0.514	310
IE3-A41R 225 M8	IE3-AU1R 225 M8		400	50	22	286	22	286	735	IE3-	91.5	91.6	90.6	0.79	44	5.7	2.3	2	2.5	0.825	360
IE3-A41R 250 M8	IE3-AU1R 250 M8		400	50	30	391	30	391	732	IE3-	91.3	91.9	91.4	0.81	58.5	5.4	2	1.8	2.3	0.92	420
IE3-A41R 280 S8	IE3-AU1R 280 S8		400	50	37	479	37	479	738	IE3-	92	92	90.8	0.78	74.5	5.9	2.3	1.8	2.4	1.55	555
IE3-A41R 280 M8	IE3-AU1R 280 M8		400	50	45	581	45	581	740	IE3-	93	93	92.4	0.78	89.5	6.5	1.7	1.5	2.4	2.63	700
IE3-A42R 315 S8	IE3-AU2R 315 S8		400	50	55	708	55	708	742	IE3-	93.3	93.3	92.4	0.78	109	7.0	1.9	1.7	2.5	3.33	805
IE3-A41R 315 M8	IE3-AU1R 315 M8		400	50	75	742	75	742	965	IE3-	93.8	94.2	93.8	0.81	142	7.0	1.9	1.7	2.3	5.55	1120
IE3-A41R 315 MX8	IE3-AU1R 315 MX8		400	50	90	1157	90	1157	743	IE3-	94.3	94.4	93.6	0.8	172	7.9	2.4	2.0	2.7	6	1185
IE3-A41R 315 MY8	IE3-AU1R 315 MY8		400	50	110	1419	110	1419	740	IE3-	93.8	94.0	93.8	0.82	206	6.5	1.9	1.5	2.1	6.76	1250
IE3-A41R 315 L8	IE3-AU1R 315 L8		400	50	132	1703	132	1703	740	IE3-	94.2	94.2	93.5	0.8	253	8.0	2.4	1.9	2.7	8.71	1450
IE3-A41R 355 MY8	IE3-AU1R 355 MY8		400	50	145	1859	145	1859	745	IE3-	94.3	94.3	94.0	0.82	299	6.6	1.2	1.0	2.6	9.3	1700
IE3-A41R 355 M8	IE3-AU1R 355 M8		400	50	180	2307	180	2307	745	IE3-	94.7	94.9	94.2	0.81	376	7.0	1.0	1.0	2.7	9.5	1890
IE3-A42R 355 MX8	IE3-AU2R 355 MX8		400	50	220	2820	220	2820	745	IE3-	94.6	94.4	93.5	0.68	561	5.2	1.4	1.3	2.0	13.40	2300
IE3-A42R 355 L8	IE3-AU2R 355 L8		400	50	250	3204	250	3204	745	IE3-	95.0	95.0	95.0	0.73	656	5.7	2.0	1.5	2.2	15.80	2450
IE3-A42R 355 LX8	IE3-AU2R 355 LX8		400	50	315	4048	315	4048	743	IE3-	94.6									15.80	2400
IE3-A42R 400 M8	IE3-AU2R 400 M8		400	50	315	4038	355	4550	745	IE3-	95.0	95.0	95.0	0.74	729	6.5	1.5	1.3	1.8	17.94	2800
IE3-A42R 400 MX8	IE3-AU2R 400 MX8		400	50	355	4550	400	5127	745	IE3-	95.6	95.5	95.0	0.69	875	5.6	1.3	1.0	2.0	19.99	3170
IE3-A42R 400 L8	IE3-AU2R 400 L8		400	50	400	5127	450	5768	745	IE3-	95.0	95.0	95.0	0.74	924	6.0	1.5	1.3	1.8	22.34	3320

Assignment tables

The three-phase roller table motors IE3-A4.R/IE3-AU.R are identical to series IE3-W4.R/IE3-WU.R
 For further information regarding the connection system, bearings and dimensions, please refer to Chapter 2.

Assignment tables					
Type	Type		J	m	
	Converter input voltage to				
420 V	500 V	420 V	500 V	kgm ²	kg
Synchronous speed 3000 rpm – 2-pole version					
IE3-A41R 132 SX2	IE3-AU1R 132 SX2	IE3-W41R 132 SX2	IE3-WU1R 132 SX2	0.0168	75
IE3-A41R 160 M2	IE3-AU1R 160 M2	IE3-W41R 160 M2	IE3-WU1R 160 M2	0.0575	125
IE3-A41R 160 MX2	IE3-AU1R 160 MX2	IE3-W41R 160 MX2	IE3-WU1R 160 MX2	0.0675	145
IE3-A41R 160 L2	IE3-AU1R 160 L2	IE3-W41R 160 L2	IE3-WU1R 160 L2	0.078	160
IE3-A41R 180 M2C	IE3-AU1R 180 M2C	IE3-W41R 180 M2C	IE3-WU1R 180 M2C	0.1717	214
IE3-A41R 200 L2	IE3-AU1R 200 L2	IE3-W41R 200 L2	IE3-WU1R 200 L2	0.36	305
IE3-A41R 200 LX2C	IE3-AU1R 200 LX2C	IE3-W41R 200 LX2C	IE3-WU1R 200 LX2C	0.4757	310
IE3-A41R 225 M2	IE3-AU1R 225 M2	IE3-W41R 225 M2	IE3-WU1R 225 M2	0.375	375
IE3-A41R 250 M2	IE3-AU1R 250 M2	IE3-W41R 250 M2	IE3-WU1R 250 M2	0.65	510
IE3-A41R 280 S2	IE3-AU1R 280 S2	IE3-W41R 280 S2	IE3-WU1R 280 S2	0.65	500
IE3-A41R 280 M2	IE3-AU1R 280 M2	IE3-W41R 280 M2	IE3-WU1R 280 M2	0.675	545
IE3-A41R 315 S2	IE3-AU1R 315 S2	IE3-W41R 315 S2	IE3-WU1R 315 S2	1.21	750
IE3-A41R 315 M2	IE3-AU1R 315 M2	IE3-W41R 315 M2	IE3-WU1R 315 M2	1.44	815
IE3-A41R 315 MX2	IE3-AU1R 315 MX2	IE3-W41R 315 MX2	IE3-WU1R 315 MX2	2.37	1095
IE3-A41R 315 MY2	IE3-AU1R 315 MY2	IE3-W41R 315 MY2	IE3-WU1R 315 MY2	2.82	1200
IE3-A41R 315 L2	IE3-AU1R 315 L2	IE3-W41R 315 L2	IE3-WU1R 315 L2	3.66	1460
IE3-A41R 315 LX2	IE3-AU1R 315 LX2	IE3-W41R 315 LX2	IE3-WU1R 315 LX2	4.43	1700
IE3-A41R 355 M2	IE3-AU1R 355 M2	IE3-W41R 355 M2	IE3-WU1R 355 M2	4.20	2000
IE3-A42R 355 MX2	IE3-AU2R 355 MX2	IE3-W42R 355 MX2	IE3-WU2R 355 MX2	5.50	2275
IE3-A42R 355 L2	IE3-AU2R 355 L2	IE3-W42R 355 L2	IE3-WU2R 355 L2	7.10	2445
IE3-A42R 400 M2	IE3-AU2R 400 M2	IE3-W42R 400 M2	IE3-WU2R 400 M2	8.44	3000
IE3-A42R 400 MX2	IE3-AU2R 400 MX2	IE3-W42R 400 MX2	IE3-WU2R 400 MX2	9.41	3200
IE3-A42R 400 L2	IE3-AU2R 400 L2	IE3-W42R 400 L2	IE3-WU2R 400 L2	10.41	3450
Synchronous speed 1500 rpm – 4-pole version					
IE3-A41R 132 M4	IE3-AU1R 132 M4	IE3-W41R 132 M4	IE3-WU1R 132 M4	0.043	100
IE3-A41R 160 M4	IE3-AU1R 160 M4	IE3-W41R 160 M4	IE3-WU1R 160 M4	0.078	125
IE3-A41R 160 L4C	IE3-AU1R 160 L4C	IE3-W41R 160 L4C	IE3-WU1R 160 L4C	0.1567	175
IE3-A41R 180 M4	IE3-AU1R 180 M4	IE3-W41R 180 M4	IE3-WU1R 180 M4	0.168	210
IE3-A41R 180 L4	IE3-AU1R 180 L4	IE3-W41R 180 L4	IE3-WU1R 180 L4	0.203	240
IE3-A41R 200 L4C	IE3-AU1R 200 L4C	IE3-W41R 200 L4C	IE3-WU1R 200 L4C	0.411	327
IE3-A41R 225 S4C	IE3-AU1R 225 S4C	IE3-W41R 225 S4C	IE3-WU1R 225 S4C	0.4675	367
IE3-A41R 225 M4	IE3-AU1R 225 M4	IE3-W41R 225 M4	IE3-WU1R 225 M4	0.619	450
IE3-A41R 250 M4	IE3-AU1R 250 M4	IE3-W41R 250 M4	IE3-WU1R 250 M4	0.95	550
IE3-A41R 280 S4	IE3-AU1R 280 S4	IE3-W41R 280 S4	IE3-WU1R 280 S4	1.1	617
IE3-A41R 280 M4	IE3-AU1R 280 M4	IE3-W41R 280 M4	IE3-WU1R 280 M4	1.96	785
IE3-A41R 315 S4	IE3-AU1R 315 S4	IE3-W41R 315 S4	IE3-WU1R 315 S4	1.96	760
IE3-A41R 315 M4	IE3-AU1R 315 M4	IE3-W41R 315 M4	IE3-WU1R 315 M4	2.27	850
IE3-A41R 315 MX4	IE3-AU1R 315 MX4	IE3-W41R 315 MX4	IE3-WU1R 315 MX4	4.01	1120
IE3-A41R 315 MY4	IE3-AU1R 315 MY4	IE3-W41R 315 MY4	IE3-WU1R 315 MY4	4.82	1250
IE3-A41R 315 L4	IE3-AU1R 315 L4	IE3-W41R 315 L4	IE3-WU1R 315 L4	5.93	1450
IE3-A41R 315 LX4	IE3-AU1R 315 LX4	IE3-W41R 315 LX4	IE3-WU1R 315 LX4	6.82	1630
IE3-A41R 355 M4	IE3-AU1R 355 M4	IE3-W41R 355 M4	IE3-WU1R 355 M4	7.90	2150
IE3-A42R 355 MX4	IE3-AU2R 355 MX4	IE3-W42R 355 MX4	IE3-WU2R 355 MX4	9.50	2410
IE3-A42R 355 L4	IE3-AU2R 355 L4	IE3-W42R 355 L4	IE3-WU2R 355 L4	10.00	2500
IE3-A42R 400 M4	IE3-AU2R 400 M4	IE3-W42R 400 M4	IE3-WU2R 400 M4	12.60	2900
IE3-A42R 400 MX4	IE3-AU2R 400 MX4	IE3-W42R 400 MX4	IE3-WU2R 400 MX4	14.33	3100
IE3-A42R 400 L4	IE3-AU2R 400 L4	IE3-W42R 400 L4	IE3-WU2R 400 L4	16.29	3400

The three-phase roller table motors IE3-A4.R/IE3-AU.R are identical to series IE3-W4.R/IE3-WU.R
 For further information regarding the connection system, bearings and dimensions, please refer to Chapter 2.

Assignment tables						
Type	Converter input voltage to		Type	Converter input voltage to		
420 V	500 V		420 V	500 V		
Synchronous speed 1000 rpm – 6-pole version						
				J	m	
				kgm ²	kg	
IE3-A41R 132 M6	IE3-AU1R 132 M6		IE3-W41R 132 M6	IE3-WU1R 132 M6	0.043	75
IE3-A41R 132 MX6	IE3-AU1R 132 MX6		IE3-W41R 132 MX6	IE3-WU1R 132 MX6	0.053	105
IE3-A41R 160 M6	IE3-AU1R 160 M6		IE3-W41R 160 M6	IE3-WU1R 160 M6	0.145	145
IE3-A41R 160 L6C	IE3-AU1R 160 L6C		IE3-W41R 160 L6C	IE3-WU1R 160 L6C	0.166	168
IE3-A41R 180 L6C	IE3-AU1R 180 L6C		IE3-W41R 180 L6C	IE3-WU1R 180 L6C	0.3396	214
IE3-A41R 200 L6	IE3-AU1R 200 L6		IE3-W41R 200 L6	IE3-WU1R 200 L6	0.514	310
IE3-A41R 200 LX6C	IE3-AU1R 200 LX6C		IE3-W41R 200 LX6C	IE3-WU1R 200 LX6C	0.6476	321
IE3-A41R 225 M6	IE3-AU1R 225 M6		IE3-W41R 225 M6	IE3-WU1R 225 M6	0.92	400
IE3-A41R 250 M6	IE3-AU1R 250 M6		IE3-W41R 250 M6	IE3-WU1R 250 M6	1.48	545
IE3-A41R 280 S6	IE3-AU1R 280 S6		IE3-W41R 280 S6	IE3-WU1R 280 S6	2.63	695
IE3-A41R 280 M6	IE3-AU1R 280 M6		IE3-W41R 280 M6	IE3-WU1R 280 M6	3.33	815
IE3-A41R 315 S6	IE3-AU1R 315 S6		IE3-W41R 315 S6	IE3-WU1R 315 S6	5.55	1060
IE3-A41R 315 M6	IE3-AU1R 315 M6		IE3-W41R 315 M6	IE3-WU1R 315 M6	6	1100
IE3-A41R 315 MX6	IE3-AU1R 315 MX6		IE3-W41R 315 MX6	IE3-WU1R 315 MX6	6.67	1210
IE3-A41R 315 L6	IE3-AU1R 315 L6		IE3-W41R 315 L6	IE3-WU1R 315 L6	8.6	1550
IE3-A41R 355 M6	IE3-AU1R 355 M6		IE3-W41R 355 M6	IE3-WU1R 355 M6	8.2	1850
IE3-A41R 355 MX6	IE3-AU1R 355 MX6		IE3-W41R 355 MX6	IE3-WU1R 355 MX6	12.10	2200
IE3-A42R 355 MX6	IE3-AU2R 355 MX6		IE3-W42R 355 MX6	IE3-WU2R 355 MX6	12.1	2350
IE3-A42R 355 LY 6	IE3-AU2R 355 LY 6		IE3-W42R 355 LY 6	IE3-WU2R 355 LY 6	14	2450
IE3-A42R 355 L6	IE3-AU2R 355 L6		IE3-W42R 355 L6	IE3-WU2R 355 L6	14	2450
IE3-A42R 400 MY6	IE3-AU2R 400 MY6		IE3-W42R 400 MY6	IE3-WU2R 400 MY6	16.54	3000
IE3-A42R 400 M6	IE3-AU2R 400 M6		IE3-W42R 400 M6	IE3-WU2R 400 M6	16.54	3000
IE3-A42R 400 MX6	IE3-AU2R 400 MX6		IE3-W42R 400 MX6	IE3-WU2R 400 MX6	18.44	3100
IE3-A42R 400 L6	IE3-AU2R 400 L6		IE3-W42R 400 L6	IE3-WU2R 400 L6	20.63	3320
Synchronous speed 750 rpm – 8-pole version						
IE3-A41R 132 S8	IE3-AU1R 132 S8		IE3-W41R 132 S8	IE3-WU1R 132 S8	0.043	80
IE3-A41R 132 M8	IE3-AU1R 132 M8		IE3-W41R 132 M8	IE3-WU1R 132 M8	0.043	74
IE3-A41R 160 M8	IE3-AU1R 160 M8		IE3-W41R 160 M8	IE3-WU1R 160 M8	0.113	119
IE3-A41R 160 MX8	IE3-AU1R 160 MX8		IE3-W41R 160 MX8	IE3-WU1R 160 MX8	0.145	143
IE3-A41R 160 L8	IE3-AU1R 160 L8		IE3-W41R 160 L8	IE3-WU1R 160 L8	0.166	155
IE3-A41R 180 L8	IE3-AU1R 180 L8		IE3-W41R 180 L8	IE3-WU1R 180 L8	0.228	175
IE3-A41R 200 L8	IE3-AU1R 200 L8		IE3-W41R 200 L8	IE3-WU1R 200 L8	0.324	235
IE3-A41R 225 S8	IE3-AU1R 225 S8		IE3-W41R 225 S8	IE3-WU1R 225 S8	0.514	310
IE3-A41R 225 M8	IE3-AU1R 225 M8		IE3-W41R 225 M8	IE3-WU1R 225 M8	0.825	360
IE3-A41R 250 M8	IE3-AU1R 250 M8		IE3-W41R 250 M8	IE3-WU1R 250 M8	0.92	420
IE3-A41R 280 S8	IE3-AU1R 280 S8		IE3-W41R 280 S8	IE3-WU1R 280 S8	1.55	555
IE3-A41R 280 M8	IE3-AU1R 280 M8		IE3-W41R 280 M8	IE3-WU1R 280 M8	2.63	700
IE3-A42R 315 S8	IE3-AU2R 315 S8		IE3-W42R 315 S8	IE3-WU2R 315 S8	3.33	805
IE3-A41R 315 M8	IE3-AU1R 315 M8		IE3-W41R 315 M8	IE3-WU1R 315 M8	5.55	1120
IE3-A41R 315 MX8	IE3-AU1R 315 MX8		IE3-W41R 315 MX8	IE3-WU1R 315 MX8	6	1185
IE3-A41R 315 MY8	IE3-AU1R 315 MY8		IE3-W41R 315 MY8	IE3-WU1R 315 MY8	6.76	1250
IE3-A41R 315 L8	IE3-AU1R 315 L8		IE3-W41R 315 L8	IE3-WU1R 315 L8	8.71	1450
IE3-A41R 355 MY8	IE3-AU1R 355 MY8		IE3-W41R 355 MY8	IE3-WU1R 355 MY8	9.3	1700
IE3-A41R 355 M8	IE3-AU1R 355 M8		IE3-W41R 355 M8	IE3-WU1R 355 M8	9.5	1890
IE3-A42R 355 MX8	IE3-AU2R 355 MX8		IE3-W42R 355 MX8	IE3-WU2R 355 MX8	13.4	2300
IE3-A42R 355 L8	IE3-AU2R 355 L8		IE3-W42R 355 L8	IE3-WU2R 355 L8	15.8	2450
IE3-A42R 355 LX8	IE3-AU2R 355 LX8		IE3-W42R 355 LX8	IE3-WU2R 355 LX8	15.8	2400
IE3-A42R 400 M8	IE3-AU2R 400 M8		IE3-W42R 400 M8	IE3-WU2R 400 M8	17.94	2800
IE3-A42R 400 MX8	IE3-AU2R 400 MX8		IE3-W42R 400 MX8	IE3-WU2R 400 MX8	19.99	3170
IE3-A42R 400 L8	IE3-AU2R 400 L8		IE3-W42R 400 L8	IE3-WU2R 400 L8	22.34	3320

Three-phase roller table motors with squirrel-cage rotor, High Efficiency IE2 light-duty version for converter-fed operation

self-ventilated, type of cooling IC 411, duty type S1, S7/S9
for rated voltage, thermal class 155 (F), degree of protection IP 55, 50 Hz

Motor selection data																	Design point 400 V. 50 Hz/460 V. 60 Hz			
Type	Converter input voltage to		U _B V	f _B Hz	P _B M _B Converter		P _B M _B Mains		n _B rpm	η _B (IEC/EN 60034-2-1)			cosφ _B	I _B A	I _x /I _B	M _x /M _B	M _y /M _B	M _k /M _B	J kgm ²	m kg
	420 V	500 V			kW	Nm	kW	Nm		100 %	75 %	50 %								
Synchronous speed 3000 rpm – 2-pole version																				
IE2-AE1R 132 SX2	IE2-AU1R 132 SX2	400	50	7.5	24.5	7.5	24.5	2925	IE2- 88.8	89.2	88.3	0.91	13.5	6.7	2.1	1.6	2.9	0.0168	75	
		460	60	9	24.5	9.0	24.5	3505	IE2- 89.5	89.4	88.5	0.90	14.0	6.2	2.1	1.7	2.8			
IE2-AE1R 160 M2	IE2-AU1R 160 M2	400	50	11	35.6	11.0	35.6	2950	IE2- 90.3	90.3	89.1	0.90	19.5	7.7	2.3	1.7	3.1	0.0258	125	
		460	60	13	35.0	13.0	35.0	3550	IE2- 91.0	90.9	89.5	0.91	20.0	7.3	2.0	1.6	2.7			
IE2-AE1R 160 MX2	IE2-AU1R 160 MX2	400	50	15	48.7	15.0	48.7	2940	IE2- 90.7	90.5	89.1	0.92	26	6.7	1.8	1.4	2.6	0.0675	140	
		460	60	16.5	44.6	16.5	44.6	3535	IE2- 90.2	89.7	88.4	0.91	25.0	6.5	1.9	1.4	2.6			
IE2-AE1R 160 L2	IE2-AU1R 160 L2	400	50	18.5	60.2	18.5	60.2	2935	IE2- 91.0	91.4	91.4	0.91	32	7.2	2.0	1.5	2.8	0.0675	140	
		460	60	22	59.6	22.0	59.6	3525	IE2- 91.6	91.3	89.6	0.92	37.5	7.0	1.8	1.3	2.6			
IE2-AE1R 180 M2	IE2-AU1R 180 M2	400	50	22	72	22	72	2935	IE2- 91.3	90.6	86.4	0.90	38.5	6.2	1.4	1.1	2.4	0.105	173	
		460	60	26	70	26	70	3545	IE2- 91.7	91.6	90.9	0.90	39.5	6.0	1.5	1.2	2.4			
IE2-AE1R 200 L2	IE2-AU1R 200 L2	400	50	30	97	30	97	2945	IE2- 92.0	91.3	90.5	0.91	52	6.9	1.7	1.3	2.6	0.128	210	
		460	60	36	97	36	97	3550	IE2- 92.4	92.5	91.6	0.91	54.0	6.0	1.4	1.1	2.3			
IE2-AE1R 200 LX2	IE2-AU1R 200 LX2	400	50	55	179	37	120	2940	IE2- 92.5	92.3	91.6	0.92	63	7.4	1.9	1.4	2.9	0.154	233	
		460	60	44	119	44	119	3545	IE2- 93.0	92.4	92.1	0.91	65.5	6.8	1.9	1.5	2.8			
IE2-AE2R 200 LX2	IE2-AU2R 200 LX2	400	50	37	120	37	120	2940	IE2- 92.5	92.3	91.6	0.92	63	7.4	1.9	1.4	2.9	0.154	233	
		460	60	44	119	44	119	3545	IE2- 93.0	92.4	92.1	0.91	65.5	6.8	1.9	1.5	2.8			
IE2-AE1R 225 M2	IE2-AU1R 225 M2	400	50	45	146	45	146	2950	IE2- 92.9	92.2	91.2	0.87	80.5	6.9	1.7	1.1	2.7	0.220	295	
		460	60	54	145	54	145	3545	IE2- 93.0	92.5	91.8	0.88	83.0	6.9	1.7	1.4	2.8			
IE2-AE1R 250 M2	IE2-AU1R 250 M2	400	50	55	178	55	178	2955	IE2- 93.5	93.7	93.2	0.89	95.5	8.2	2.3	1.9	2.8	0.375	385	
		460	60	66	178	66	178	3550	IE2- 93.6	93.7	93.0	0.90	98.5	7.6	2.1	1.8	2.7			
IE2-AE1R 280 S2	IE2-AU1R 280 S2	400	50	74	238	75	241	2970	IE2- 94.1	94.0	91.5	0.90	128	7.9	2.1	1.7	3.0	0.65	500	
		460	60	89	238	90	241	3570	IE2- 94.5	93.9	92.8	0.91	131	7.3	1.9	1.6	2.8			
IE2-AE1R 280 M2	IE2-AU1R 280 M2	400	50	87	280	90	289	2970	IE2- 94.4	94.1	91.9	0.91	151	7.7	2.0	1.7	2.8	0.68	550	
		460	60	106	284	110	294	3568	IE2- 94.5	94.0	93.7	0.91	161	7.5	1.9	1.6	2.7			
IE2-AE1R 315 S2	IE2-AU1R 315 S2	400	50	110	353	110	353	2975	IE2- 94.5	94.3	93.3	0.89	189	8.0	1.3	1.2	2.4	1.21	730	
		460	60	120	320	120	320	3580	IE2- 94.5	94.0	93.0	0.89	179	8.5	1.4	1.3	2.5			
IE2-AE1R 315 M2	IE2-AU1R 315 M2	400	50	132	424	132	424	2975	IE2- 95.0	94.8	94.5	0.89	225	9.2	1.4	1.2	2.4	1.44	820	
		460	60	145	387	145	387	3580	IE2- 95.0	94.5	94.0	0.90	213	9.4	1.4	1.2	2.4			
IE2-AE1R 315 MX2	IE2-AU1R 315 MX2	400	50	160	514	160	514	2973	IE2- 94.8	94.8	94.8	0.89	274	8.2	1.3	1.3	2.4	1.76	955	
		460	60	175	467	175	467	3575	IE2- 95.4	95.0	94.0	0.90	256	8.2	1.7	1.6	2.7			
IE2-AE1R 315 MY2	IE2-AU1R 315 MY2	400	50	200	640	200	640	2983	IE2- 95.4	95.0	94.3	0.88	344	9.4	2.8	2.0	3.0	2.82	1200	
		460	60	220	586	220	586	3585	IE2- 95.4	95.0	94.0	0.89	325	9.5	2.8	2.0	3.0			
IE2-AE1R 315 L2	IE2-AU1R 315 L2	400	50	220	704	250	800	2984	IE2- 95.4	95.4	95.4	0.92	411	9.0	2.3	1.2	2.3	3.66	1450	
		460	60	246	656	280	747	3580	IE2- 95.5	95.5	95.5	0.92	400	8.0	2.3	1.4	2.3			
IE2-AE1R 315 LX2	IE2-AU1R 315 LX2	400	50	270	864	315	1008	2985	IE2- 95.4	95.4	95.0	0.92	518	8.5	2.8	1.6	2.5	4.43	1700	
		460	60	283	754	330	879	3585	IE2- 95.4	95.4	95.4	0.92	472	9.0	2.8	1.6	2.5			
IE2-AE2R 355 M2	IE2-AU2R 355 M2	400	50	330	1056	355	1136	2985	IE2- 95.5	95.5	95.5	0.92	583	7.7	1.3	1.0	2.6	4.20	2000	
		460	60	349	930	375	999	3585	IE2- 95.4	95.0	94.5	0.91	542	8.5	1.5	1.3	2.2			
IE2-AE2R 355 MX2	IE2-AU2R 355 MX2	400	50	355	1134	400	1278	2990	IE2- 95.5	95.5	95.5	0.91	664	9.4	1.8	1.0	3.0	4.50	2200	
		460	60	391	1040	440	1170	3590	IE2- 95.8	95.5	95.0	0.91	633	9.4	1.7	1.1	3.0			
IE2-AE2R 355 LY2	IE2-AU2R 355 LY2	400	50	425	1360	450	1440	2985	IE2- 95.5	95.5	95.5	0.92	739	7.0	1.3	0.9	2.4	7.10	2400	
		460	60	463	1232	490	1303	3590	IE2- 95.5	95.5	95.0	0.92	700	7.5	1.5	0.9	2.4			
IE2-AE2R 355 L2	IE2-AU2R 355 L2	400	50	425	1357	500	1597	2990	IE2- 95.5	95.5	95.5	0.92	821	8.5	1.5	1.2	2.5	7.10	2400	
		460	60	468	1248	550	1467	3580	IE2- 95.5	95.5	95.0	0.92	786	8.5	1.5	1.0	2.4			

Three-phase roller table motors with squirrel-cage rotor, High Efficiency IE2 light-duty version for converter-fed operation

self-ventilated, type of cooling IC 411, duty type S1, S7/S9
for rated voltage, thermal class 155 (F), degree of protection IP 55, 50 Hz

Motor selection data															Design point 400 V. 50 Hz/460 V. 60 Hz						
Type	Converter input voltage to		U _B V	f _B Hz	P _B M _B Converter		P _B M _B Mains		n _B rpm	η _B (IEC/EN 60034-2-1)			cosφ _B	I _B A	I _x /I _B	M _x /M _B	M _S /M _B	M _K /M _B	J kgm ²	m kg	
	420 V	500 V			P _B kW	M _B Nm	P _B kW	M _B Nm		100 %	75 %	50 %									
Synchronous speed 1000 rpm – 6-pole version																					
IE2-AE1R 132 M6	IE2-AU1R 132 M6	400	50	4.0	39.6	4.0	39.6	965	IE2- 85.5	85.5	83.8	0.79	8.5	5.1	1.8	1.6	2.4	0.043	76		
		460	60	4.5	36.9	4.5	36.9	1165	IE2- 87.5	86.0	83.4	0.79	8	5.3	1.8	1.6	2.5				
IE2-AE1R 132 MX6	IE2-AU1R 132 MX6	400	50	5.5	54	5.5	54	970	IE2- 86.1	85.5	82.4	0.77	12	5.7	2.2	1.7	2.7	0.053	85		
		460	60	6.6	54	6.6	54	1170	IE2- 89.5	88.5	87.1	0.8	11.5	5.6	1.9	1.7	2.9				
IE2-AE1R 160 M6	IE2-AU1R 160 M6	400	50	7.5	73	7.5	73	975	IE2- 87.4	88.1	86.0	0.81	15.5	6.3	2.5	2.1	2.9	0.113	118		
		460	60	9.0	73	9.0	73	1175	IE2- 89.5	88.9	87.0	0.82	16	5.8	2.2	2.0	2.7				
IE2-AE2R 160 M6	IE2-AU2R 160 M6	400	50	7.5	74	7.5	74	970	IE2- 87.5	87.6	85.9	0.79	15.5	5.9	2.1	1.8	2.9	0.053	103		
		460	60	9	73	9	73	1170	IE2- 89	89	87.7	0.81	15.5	5.7	1.9	1.7	2.7				
IE2-AE1R 160 L6	IE2-AU1R 160 L6	400	50	11.0	108	11.0	108	970	IE2- 88.7	87.9	86.3	0.85	21	5.8	2.2	1.9	2.7	0.145	135		
		460	60	11.0		11.0															
IE2-AE2R 160 L6	IE2-AU2R 160 L6	400	50	11.0	108	11.0	108	975	IE2- 88.9	88.8	87.0	0.81	22	6.8	2.7	2.4	3.1	0.166	155		
		460	60	13	106	13	106	1175	IE2- 90.3	89.9	88.1	0.83	22	6.4	2.5	2.2	2.8				
IE2-AE1R 180 L6	IE2-AU1R 180 L6	400	50	15.0	147	15.0	147	975	IE2- 89.7	88.8	86.7	0.84	28.5	6.2	2.1	1.8	2.8	0.228	185		
		460	60	16.5	134	16.5	134	1175	IE2- 90.2	89.8	88.4	0.85	27.0	7.3	2.2	1.9	2.7				
IE2-AE2R 180 L6	IE2-AU2R 180 L6	400	50	15	148	15	148	970	IE2- 89.7	88.8	87.8	0.83	29	5.6	2.3	1.7	2.6	0.166	157		
		460	60	15	122	15	122	1175	IE2- 90.2	89.5	87.4	0.83	25	6.3	2.5	1.9	2.9				
IE2-AE1R 200 L6	IE2-AU1R 200 L6	400	50	18.5	180	18.5	180	980	IE2- 90.4	88.8	86.5	0.85	35	6.6	2.3	1.7	2.9	0.268	208		
		460	60	22.0	179	22.0	179	1175	IE2- 91.7	90.1	88.5	0.85	35.5	6.6	2.2	1.8	2.7				
IE2-AE1R 200 LX6	IE2-AU1R 200 LX6	400	50	22	214	22	214	980	IE2- 90.9	90.2	88.5	0.86	40.5	6.4	2.2	1.8	2.7	0.443	272		
		460	60	25	202	25	202	1180	IE2- 91.7	91.2	90.0	0.86	40.0	6.4	2.2	1.8	2.7				
IE2-AE2R 200 LX6	IE2-AU2R 200 LX6	400	50	22	215	22	215	975	IE2- 90.9	89.9	88.5	0.84	41.5	6.7	2.4	2.0	3.0	0.324	238		
		460	60	25	202	25	202	1180	IE2- 91.7	90.8	89.5	0.86	40	6.6	2.3	1.9	2.9				
IE2-AE1R 225 M6	IE2-AU1R 225 M6	400	50	30	291	30	291	985	IE2- 92.0	91.5	90.0	0.86	54.5	7.3	2.5	2.2	2.9	0.825	365		
		460	60	36	291	36	291	1182	IE2- 93.0	92.0	90.5	0.85	57.0	7.1	2.3	2.0	2.6				
IE2-AE2R 225 M6	IE2-AU2R 225 M6	400	50	30	294	30	294	975	IE2- 91.7	91.4	90.6	0.87	54.5	6.7	2.3	1.9	2.8	0.514	308		
		460	60	25	201	25	201	1185	IE2- 91.7	90.8	88.1	0.86	40	8.2	2.9	2.4	3.7				
IE2-AE1R 250 M6	IE2-AU1R 250 M6	400	50	37	359	37	359	985	IE2- 92.2	91.7	90.7	0.85	68	6.4	2.7	1.8	2.4	1.28	480		
		460	60	40	322	40	322	1185	IE2- 93.0	92.0	90.5	0.86	63	6.6	2.7	1.8	2.5				
IE2-AE2R 250 M6	IE2-AU2R 250 M6	400	50	37	361	37	361	979	IE2- 92.2	92.3	91.8	0.86	67.5	6.6	2.7	2.0	2.6	0.92	407		
		460	60	40	324	40	324	1179	IE2- 93	93.4	91.8	0.86	63	6.7	2.7	2.1	2.6				
IE2-AE1R 280 S6	IE2-AU1R 280 S6	400	50	45	437	45	437	983	IE2- 93.0	92.7	92.4	0.87	80.5	6.5	2.2	1.7	2.4	1.48	560		
		460	60	49	395	49	395	1185	IE2- 93.6	92.4	91.0	0.87	75.5	6.7	2.3	1.9	2.6				
IE2-AE1R 280 M6	IE2-AU1R 280 M6	400	50	55	531	55	531	990	IE2- 93.5	93.5	93.0	0.85	100	7.6	2.0	1.5	2.5	2.63	710		
		460	60	64	514	64	514	1190	IE2- 94.1	93.5	93.0	0.84	102	8.0	2.1	1.6	2.7				
IE2-AE1R 315 S6	IE2-AU1R 315 S6	400	50	75	723	75	723	990	IE2- 93.9	93.7	93.5	0.87	133	7.8	1.9	1.5	2.5	3.33	804		
		460	60	90	722	90	722	1190	IE2- 94.1	93.5	93.0	0.87	138	7.5	1.8	1.6	2.5				
IE2-AE1R 315 M6	IE2-AU1R 315 M6	400	50	90	868	90	868	990	IE2- 94.0	94.0	93.5	0.88	157	7.5	1.8	1.5	2.5	3.60	865		
		460	60	99	794	99	794	1190	IE2- 94.1	94.0	93.5	0.87	152	8.0	2.1	1.6	2.6				
IE2-AE1R 315 MX6	IE2-AU1R 315 MX6	400	50	110	1061	110	1061	990	IE2- 94.3	94.3	94.0	0.87	194	7.5	1.8	1.4	2.3	6.67	1210		
		460	60	110	883	110	883	1190	IE2- 95.0	94.6	94.2	0.87	167	8.3	2.0	1.7	2.6				
IE2-AE1R 315 MY6	IE2-AU1R 315 MY6	400	50	132	1273	132	1273	990	IE2- 94.6	94.3	94.0	0.87	231	7.5	1.9	1.4	2.2	6.67	1250		
		460	60	145	1164	145	1164	1190	IE2- 95.0	95.0	94.5	0.86	223	8.0	2.0	1.5	2.4				
IE2-AE1R 315 L6	IE2-AU1R 315 L6	400	50	160	1543	160	1543	990	IE2- 94.8	94.5	93.5	0.88	277	7.5	2.0	1.5	2.4	8.60	1430		
		460	60	175	1404	175	1404	1190	IE2- 95.0	94.8	94.3	0.87	266	8.0	2.0	1.5	2.4				
IE2-AE1R 315 LX6	IE2-AU1R 315 LX6	400	50	185	1785	200	1929	990	IE2- 95.0	95.0	94.5	0.86	353	7.0	1.9	1.5	2.2	8.60	1460		
		460	60	204	1637	220	1766	1190	IE2- 95.0	95.0	94.5	0.86	338	7.0	1.9	1.5	2.3				
IE2-AE2R 355 M6	IE2-AU2R 355 M6	400	50	250	2402	250	2402	994	IE2- 95.0	95.0	94.7	0.84	452	7.0	1.5	1.2	2.2	8.20	1850		
		460	60	280	2241	280	2241	1193	IE2- 95.0	94.5	93.5	0.83	446	8.0	1.7	1.3	2.5				
IE2-AE2R 355 MX6	IE2-AU2R 355 MX6	400	50	300	2879	315	3023	995	IE2- 95.2	95.2	95.2	0.86	555	7.0	1.3	1.1	2.2	12.1	2200		
		460	60	314	2505	330	2633	1197	IE2- 95.2	95.2	95.2	0.86	506	7.0	1.3	1.1	2.2				
IE2-AE2R 355 LY6	IE2-AU2R 355 LY6	400	50	315	3023	355	3407	995	IE2- 95.0	95.0	94.0	0.77	700	7.5	1.8	1.5	2.6	14.0	2400		
		460	60	333	2661	375	2997	1195	IE2- 95.0	94.5	93.5	0.76	652	8.0	1.9	1.6	2.8				

Three-phase roller table motors with squirrel-cage rotor, High Efficiency IE2 light-duty version for converter-fed operation

self-ventilated, type of cooling IC 411, duty type S1, S7/S9
for rated voltage, thermal class 155 (F), degree of protection IP 55, 50 Hz

Motor selection data		Design point 400 V. 50 Hz/460 V. 60 Hz																		
Type	Converter input voltage to		U _B V	f _B Hz	P _B M _B Converter		P _B M _B Mains		n _B rpm	η _B (IEC/EN 60034-2-1)			cos φ _B	I _B A	I _x /I _B	M _x /M _B	M _y /M _B	M _k /M _B	J kgm ²	m kg
	420 V	500 V			P _B kW	M _B Nm	P _B kW	M _B Nm		100 %	75 %	50 %								
Synchronous speed 750 rpm – 8-pole version																				
IE2-AE1R 132 M8	IE2-AU1R 132 M8	400	50	3	39.8	3.0	39.8	720	IE2-	82.7	83.0	81.3	0.74	7.1	3.9	1.6	1.3	1.9	0.0430	74
		460	60	3.6	39.5	3.6	39.5	870	-	84.2	84.5	83.0	0.75	7.2	3.6	1.4	1.2	1.8		
IE2-AE1R 160 M8	IE2-AU1R 160 M8	400	50	4	53.2	4.0	53.2	718	IE2-	84.2	83.7	81.9	0.72	9.5	4.6	1.6	***	2.5	0.0530	86
		460	60	4		4.0														
IE2-AE1R 160 MX8	IE2-AU1R 160 MX8	400	50	5.5	72	5.5	72.0	730	IE2-	86.9	86.6	84.1	0.72	12.5	4.8	2.1	1.8	2.6	0.1130	115
		460	60	6.6	72	6.6	72	875	-	87.8	87.2	84.6	0.74	12.7	4.9	2.0	1.6	2.4		
IE2-AE2R 160 MX8	IE2-AU2R 160 MX8	400	50	5.5	73	5.5	73	715	IE2-	83.9	84.0	81.9	0.71	13.5	4.3	1.7	1.5	2.5	0.0530	103
		460	60	6.6	73	6.6	73	865	-	86.4	86.7	85.3	0.72	13.5	4.2	1.6	1.4	2.3		
IE2-AE1R 160 L8	IE2-AU1R 160 L8	400	50	7.5	99	7.5	99	725	IE2-	87.5	87.0	83.5	0.77	16	5.5	2.0	***	2.8	0.1450	136
		460	60	7.5		7.5														
IE2-AE1R 180 L8	IE2-AU1R 180 L8	400	50	11	144	11.0	144	727	IE2-	88.2	88.2	86.7	0.78	23	4.9	1.8	1.6	2.4	0.2280	175
		460	60	13	141	13.0	141	878	-	89.4	89.4	87.9	0.78	23.5	4.6	1.7	1.5	2.3		
IE2-AE2R 180 L8	IE2-AU2R 180 L8	400	50	11	144	11	144	730	IE2-	87.9	87.4	85.2	0.67	25.5	4.3	1.9	1.6	2.3	0.1660	157
		460	60	13		13														
IE2-AE1R 200 L8	IE2-AU1R 200 L8	400	50	15	197	15.0	197	727	IE2-	88.2	88.1	86.4	0.77	32	4.9	1.9	1.7	2.3	0.2680	200
		460	60	18	196	18.0	196	878	-	88.9	88.7	87.4	0.78	32.5	4.8	1.8	1.6	2.2		
IE2-AE1R 225 S8	IE2-AU1R 225 S8	400	50	18.5	242	18.5	242	730	IE2-	89.6	89.4	87.2	0.78	38	5.4	2.1	2.0	2.8	0.440	265
		460	60	22	239	22	239	880	-	89.9	89.6	87.5	0.79	39.0	5.2	2.0	1.9	2.7		
IE2-AE2R 225 S8	IE2-AU2R 225 S8	400	50	18.5	240	18.5	240	735	IE2-	90.7	90.7	89.4	0.8	37	6.1	2.1	1.9	2.9	0.514	305
		460	60	22	237	22	237	885	-	91.8	91.5	90.2	0.81	37.0	5.7	2	1.7	2.6		
IE2-AE1R 225 M8	IE2-AU1R 225 M8	400	50	22	287	22	287	733	IE2-	90.6	89.4	89.9	0.78	45	5.6	2.2	1.8	2.6	0.825	380
		460	60	33	356	33	356	885	-	91.5	91.0	89.5	0.78	58.0	5.6	2.1	1.8	2.4		
IE2-AE2R 225 M8	IE2-AU2R 225 M8	400	50	22	286	22	286	735	IE2-	90.3	90.3	88.7	0.77	45.5	6.1	2.2	2.0	2.9	0.514	307
		460	60	26	281	26	281	883	-	91.3	91.1	89.6	0.79	45.0	5.9	2.1	1.8	2.7		
IE2-AE1R 250 M8	IE2-AU1R 250 M8	400	50	30	389	30	389	737	IE2-	92.1	92.4	91.6	0.79	59.5	5.0	2.0	1.6	2.1	1.350	480
		460	60	37	398	37	398	887	-	91.7	91.5	90.0	0.80	63.5	4.7	1.7	1.3	1.8		
IE2-AE2R 250 M8	IE2-AU2R 250 M8	400	50	30	391	30	391	732	IE2-	91.5	91.7	90.9	0.77	61.5	5.6	2.3	2.0	2.5	0.950	405
		460	60	36	391	36	391	880	-	91.9	92.3	91.8	0.78	63.0	5.3	2.1	1.8	2.3		
IE2-AE1R 280 S8	IE2-AU1R 280 S8	400	50	37	479	37	479	737	IE2-	92.2	92.1	90.9	0.79	73.5	6.0	2.3	1.9	2.5	1.55	550
		460	60	45	484	45	484	888	-	91.7	91.2	89.0	0.79	78.0	6.0	2.1	1.6	2.2		
IE2-AE1R 280 M8	IE2-AU1R 280 M8	400	50	45	581	45	581	740	IE2-	92.7	92.7	92.0	0.79	88.5	6.7	1.8	1.5	2.5	2.63	690
		460	60	45		45														
IE2-AE1R 315 S8	IE2-AU1R 315 S8	400	50	55	710	55	710	740	IE2-	92.2	92.2	92.1	0.80	108	6.3	1.8	1.5	2.3	2.63	690
		460	60	66	708	66	708	890	-	93	93	92.5	0.8	111	5.8	1.6	1.4	2		
IE2-AE1R 315 M8	IE2-AU1R 315 M8	400	50	75	968	75	968	740	IE2-	93.5	93.5	93.0	0.81	143	6.0	1.8	1.5	2.1	3.6	880
		460	60	75		75														
IE2-AE1R 315 MX8	IE2-AU1R 315 MX8	400	50	90	1161	90	1161	740	IE2-	92.1	91.6	90.1	0.81	174	6.0	1.9	***	2.2	6	1050
		460	60	90		90														
IE2-AE1R 315 MY8	IE2-AU1R 315 MY8	400	50	110	1420	110	1420	740	IE2-	93.8	93.3	91.2	0.81	209	6.5	2.1	***	2.4	6.76	1250
		460	60			10														
IE2-AE1R 315 L8	IE2-AU1R 315 L8	400	50	132	1704	132	1704	740	IE2-	94.4	94.0	93.5	0.83	243	7.5	2.2	1.8	2.5	8.71	1430
		460	60	132		132														
IE2-AE1R 315 LX8	IE2-AU1R 315 LX8	400	50	145	1871	160	2065	740	IE2-	94.2	94.2	93.8	0.80	306	7.2	2.2	1.8	2.5	8.71	1430
		460	60	190	2039	190	2039	890	-	94.3	94.3	94.0	0.81	312	7.0	2.1	1.7	2.3		
IE2-AE2R 355 M8	IE2-AU2R 355 M8	400	50	200	2571	200	2571	743	IE2-	94.7	94.1	91.5	0.77	396	***	***	***	***	9.5	1850
		460	60	200		200														
IE2-AE2R 355 MX8	IE2-AU2R 355 MX8	400	50	225	2884	250	3205	745	IE2-	95.8	95.8	95.5	0.83	454	7.0	1.2	1.0	2.6	13.4	2200
		460	60	225		250														
IE2-AE2R 355 LY8	IE2-AU2R 355 LY8	400	50	230	2956	280	3599	743	IE2-	94.8	94.1	91.5	0.78	547	***	***	***	***	15.8	2400
		460	60	230		280														

***) upon request

Assignment tables

Die Three-phase roller table motors IE2-AE.R/IE2-AU.R are identical to series IE2-WE.R/IE2-WU.R
 For further information regarding the connection system, bearings and dimensions, please refer to Chapter 2.

Assignment tables						
Type	Converter input voltage to		Type	Converter input voltage to		
	420 V	500 V	420 V	500 V		
Synchronous speed 3000 rpm – 2-pole version						
				J	m	
				kgm ²	kg	
IE2-AE1R 132 SX2	IE2-AU1R 132 SX2		IE2-WE1R 132 SX2	IE2-WU1R 132 SX2	0.0168	75
IE2-AE1R 160 M2	IE2-AU1R 160 M2		IE2-WE1R 160 M2	IE2-WU1R 160 M2	0.0258	125
IE2-AE1R 160 MX2	IE2-AU1R 160 MX2		IE2-WE1R 160 MX2	IE2-WU1R 160 MX2	0.0675	140
IE2-AE1R 160 L2	IE2-AU1R 160 L2		IE2-WE1R 160 L2	IE2-WU1R 160 L2	0.0675	140
IE2-AE1R 180 M2	IE2-AU1R 180 M2		IE2-WE1R 180 M2	IE2-WU1R 180 M2	0.105	173
IE2-AE1R 200 L2	IE2-AU1R 200 L2		IE2-WE1R 200 L2	IE2-WU1R 200 L2	0.128	210
IE2-AE1R 200 LX2	IE2-AU1R 200 LX2		IE2-WE1R 200 LX2	IE2-WU1R 200 LX2	0.154	233
IE2-AE2R 200 LX2	IE2-AU2R 200 LX2		IE2-WE2R 200 LX2	IE2-WU2R 200 LX2	0.154	233
IE2-AE1R 225 M2	IE2-AU1R 225 M2		IE2-WE1R 225 M2	IE2-WU1R 225 M2	0.220	295
IE2-AE1R 250 M2	IE2-AU1R 250 M2		IE2-WE1R 250 M2	IE2-WU1R 250 M2	0.375	385
IE2-AE1R 280 S2	IE2-AU1R 280 S2		IE2-WE1R 280 S2	IE2-WU1R 280 S2	0.65	500
IE2-AE1R 280 M2	IE2-AU1R 280 M2		IE2-WE1R 280 M2	IE2-WU1R 280 M2	0.68	550
IE2-AE1R 315 S2	IE2-AU1R 315 S2		IE2-WE1R 315 S2	IE2-WU1R 315 S2	1.21	730
IE2-AE1R 315 M2	IE2-AU1R 315 M2		IE2-WE1R 315 M2	IE2-WU1R 315 M2	1.44	820
IE2-AE1R 315 MX2	IE2-AU1R 315 MX2		IE2-WE1R 315 MX2	IE2-WU1R 315 MX2	1.76	955
IE2-AE1R 315 MY2	IE2-AU1R 315 MY2		IE2-WE1R 315 MY2	IE2-WU1R 315 MY2	2.82	1200
IE2-AE1R 315 L2	IE2-AU1R 315 L2		IE2-WE1R 315 L2	IE2-WU1R 315 L2	3.66	1450
IE2-AE1R 315 LX2	IE2-AU1R 315 LX2		IE2-WE1R 315 LX2	IE2-WU1R 315 LX2	4.43	1700
IE2-AE2R 355 M2	IE2-AU2R 355 M2		IE2-WE2R 355 M2	IE2-WU2R 355 M2	4.20	2000
IE2-AE2R 355 MX2	IE2-AU2R 355 MX2		IE2-WE2R 355 MX2	IE2-WU2R 355 MX2	4.50	2200
IE2-AE2R 355 LY2	IE2-AU2R 355 LY2		IE2-WE2R 355 LY2	IE2-WU2R 355 LY2	7.10	2400
IE2-AE2R 355 L2	IE2-AU2R 355 L2		IE2-WE2R 355 L2	IE2-WU2R 355 L2	7.10	2400

Synchronous speed 1500 rpm – 4-pole version						
				J	m	
				kgm ²	kg	
IE2-AE1R 132 S4	IE2-AU1R 132 S4		IE2-WE1R 132 S4	IE2-WU1R 132 S4	0.035	87
IE2-AE1R 132 M4	IE2-AU1R 132 M4		IE2-WE1R 132 M4	IE2-WU1R 132 M4	0.035	88
IE2-AE1R 160 M4	IE2-AU1R 160 M4		IE2-WE1R 160 M4	IE2-WU1R 160 M4	0.078	122
IE2-AE2R 160 M4	IE2-AU2R 160 M4		IE2-WE2R 160 M4	IE2-WU2R 160 M4	0.043	105
IE2-AE1R 160 L4	IE2-AU1R 160 L4		IE2-WE1R 160 L4	IE2-WU1R 160 L4	0.115	160
IE2-AE2R 160 L4	IE2-AU2R 160 L4		IE2-WE2R 160 L4	IE2-WU2R 160 L4	0.115	161
IE2-AE1R 180 M4	IE2-AU1R 180 M4		IE2-WE1R 180 M4	IE2-WU1R 180 M4	0.168	207
IE2-AE2R 180 M4	IE2-AU2R 180 M4		IE2-WE2R 180 M4	IE2-WU2R 180 M4	0.138	176
IE2-AE1R 180 L4	IE2-AU1R 180 L4		IE2-WE1R 180 L4	IE2-WU1R 180 L4	0.168	215
IE2-AE1R 200 L4	IE2-AU1R 200 L4		IE2-WE1R 200 L4	IE2-WU1R 200 L4	0.275	277
IE2-AE1R 225 S4	IE2-AU1R 225 S4		IE2-WE1R 225 S4	IE2-WU1R 225 S4	0.313	313
IE2-AE1R 225 M4	IE2-AU1R 225 M4		IE2-WE1R 225 M4	IE2-WU1R 225 M4	0.525	390
IE2-AE2R 225 M4	IE2-AU2R 225 M4		IE2-WE2R 225 M4	IE2-WU2R 225 M4	0.356	346
IE2-AE1R 250 M4	IE2-AU1R 250 M4		IE2-WE1R 250 M4	IE2-WU1R 250 M4	0.95	535
IE2-AE2R 250 M4	IE2-AU2R 250 M4		IE2-WE2R 250 M4	IE2-WU2R 250 M4	0.62	435
IE2-AE1R 280 S4	IE2-AU1R 280 S4		IE2-WE1R 280 S4	IE2-WU1R 280 S4	0.95	550
IE2-AE1R 280 M4	IE2-AU1R 280 M4		IE2-WE1R 280 M4	IE2-WU1R 280 M4	1.10	610
IE2-AE1R 315 S4	IE2-AU1R 315 S4		IE2-WE1R 315 S4	IE2-WU1R 315 S4	1.96	760
IE2-AE1R 315 M4	IE2-AU1R 315 M4		IE2-WE1R 315 M4	IE2-WU1R 315 M4	2.27	850
IE2-AE1R 315 MX4	IE2-AU1R 315 MX4		IE2-WE1R 315 MX4	IE2-WU1R 315 MX4	2.73	975
IE2-AE1R 315 MY4	IE2-AU1R 315 MY4		IE2-WE1R 315 MY4	IE2-WU1R 315 MY4	4.82	1270
IE2-AE1R 315 L4	IE2-AU1R 315 L4		IE2-WE1R 315 L4	IE2-WU1R 315 L4	5.93	1450
IE2-AE1R 315 LX4	IE2-AU1R 315 LX4		IE2-WE1R 315 LX4	IE2-WU1R 315 LX4	6.82	1630
IE2-AE2R 355 M4	IE2-AU2R 355 M4		IE2-WE2R 355 M4	IE2-WU2R 355 M4	7.90	2150
IE2-AE2R 355 MX4	IE2-AU2R 355 MX4		IE2-WE2R 355 MX4	IE2-WU2R 355 MX4	9.50	2400
IE2-AE2R 355 LY4	IE2-AU2R 355 LY4		IE2-WE2R 355 LY4	IE2-WU2R 355 LY4	10.00	2500
IE2-AE2R 355 L4	IE2-AU2R 355 L4		IE2-WE2R 355 L4	IE2-WU2R 355 L4	10.00	2500

Die Three-phase roller table motors IE2-AE.R/IE2-AU.R are identical to series IE2-WE.R/IE2-WU.R
 For further information regarding the connection system, bearings and dimensions, please refer to Chapter 2.

Assignment tables						
Type	Converter input voltage to		Type	Converter input voltage to		
	420 V	500 V	420 V	500 V		
					J	
					m	
					kgm ²	
					kg	
Synchronous speed 1000 rpm – 6-pole version						
IE2-AE1R 132 M6	IE2-AU1R 132 M6	IE2-AU1R 132 M6	IE2-WE1R 132 M6	IE2-WU1R 132 M6	0.043	76
IE2-AE1R 132 MX6	IE2-AU1R 132 MX6	IE2-AU1R 132 MX6	IE2-WE1R 132 MX6	IE2-WU1R 132 MX6	0.053	85
IE2-AE1R 160 M6	IE2-AU1R 160 M6	IE2-AU1R 160 M6	IE2-WE1R 160 M6	IE2-WU1R 160 M6	0.113	118
IE2-AE2R 160 M6	IE2-AU2R 160 M6	IE2-AU2R 160 M6	IE2-WE2R 160 M6	IE2-WU2R 160 M6	0.053	103
IE2-AE1R 160 L6	IE2-AU1R 160 L6	IE2-AU1R 160 L6	IE2-WE1R 160 L6	IE2-WU1R 160 L6	0.145	135
IE2-AE2R 160 L6	IE2-AU2R 160 L6	IE2-AU2R 160 L6	IE2-WE2R 160 L6	IE2-WU2R 160 L6	0.166	155
IE2-AE1R 180 L6	IE2-AU1R 180 L6	IE2-AU1R 180 L6	IE2-WE1R 180 L6	IE2-WU1R 180 L6	0.228	185
IE2-AE2R 180 L6	IE2-AU2R 180 L6	IE2-AU2R 180 L6	IE2-WE2R 180 L6	IE2-WU2R 180 L6	0.166	157
IE2-AE1R 200 L6	IE2-AU1R 200 L6	IE2-AU1R 200 L6	IE2-WE1R 200 L6	IE2-WU1R 200 L6	0.268	208
IE2-AE1R 200 LX6	IE2-AU1R 200 LX6	IE2-AU1R 200 LX6	IE2-WE1R 200 LX6	IE2-WU1R 200 LX6	0.443	272
IE2-AE2R 200 LX6	IE2-AU2R 200 LX6	IE2-AU2R 200 LX6	IE2-WE2R 200 LX6	IE2-WU2R 200 LX6	0.324	238
IE2-AE1R 225 M6	IE2-AU1R 225 M6	IE2-AU1R 225 M6	IE2-WE1R 225 M6	IE2-WU1R 225 M6	0.825	365
IE2-AE2R 225 M6	IE2-AU2R 225 M6	IE2-AU2R 225 M6	IE2-WE2R 225 M6	IE2-WU2R 225 M6	0.514	308
IE2-AE1R 250 M6	IE2-AU1R 250 M6	IE2-AU1R 250 M6	IE2-WE1R 250 M6	IE2-WU1R 250 M6	1.28	480
IE2-AE2R 250 M6	IE2-AU2R 250 M6	IE2-AU2R 250 M6	IE2-WE2R 250 M6	IE2-WU2R 250 M6	0.92	407
IE2-AE1R 280 S6	IE2-AU1R 280 S6	IE2-AU1R 280 S6	IE2-WE1R 280 S6	IE2-WU1R 280 S6	1.48	560
IE2-AE1R 280 M6	IE2-AU1R 280 M6	IE2-AU1R 280 M6	IE2-WE1R 280 M6	IE2-WU1R 280 M6	2.63	710
IE2-AE1R 315 S6	IE2-AU1R 315 S6	IE2-AU1R 315 S6	IE2-WE1R 315 S6	IE2-WU1R 315 S6	3.33	804
IE2-AE1R 315 M6	IE2-AU1R 315 M6	IE2-AU1R 315 M6	IE2-WE1R 315 M6	IE2-WU1R 315 M6	3.60	865
IE2-AE1R 315 MX6	IE2-AU1R 315 MX6	IE2-AU1R 315 MX6	IE2-WE1R 315 MX6	IE2-WU1R 315 MX6	6.67	1210
IE2-AE1R 315 MY6	IE2-AU1R 315 MY6	IE2-AU1R 315 MY6	IE2-WE1R 315 MY6	IE2-WU1R 315 MY6	6.67	1250
IE2-AE1R 315 L6	IE2-AU1R 315 L6	IE2-AU1R 315 L6	IE2-WE1R 315 L6	IE2-WU1R 315 L6	8.60	1430
IE2-AE1R 315 LX6	IE2-AU1R 315 LX6	IE2-AU1R 315 LX6	IE2-WE1R 315 LX6	IE2-WU1R 315 LX6	8.60	1460
IE2-AE2R 355 M6	IE2-AU2R 355 M6	IE2-AU2R 355 M6	IE2-WE2R 355 M6	IE2-WU2R 355 M6	8.20	1850
IE2-AE2R 355 MX6	IE2-AU2R 355 MX6	IE2-AU2R 355 MX6	IE2-WE2R 355 MX6	IE2-WU2R 355 MX6	12.1	2200
IE2-AE2R 355 LY6	IE2-AU2R 355 LY6	IE2-AU2R 355 LY6	IE2-WE2R 355 LY6	IE2-WU2R 355 LY6	14.0	2400
Synchronous speed 750 rpm – 8-pole version						
IE2-AE1R 132 M8	IE2-AU1R 132 M8	IE2-AU1R 132 M8	IE2-WE1R 132 M8	IE2-WU1R 132 M8	0.0430	74
IE2-AE1R 160 M8	IE2-AU1R 160 M8	IE2-AU1R 160 M8	IE2-WE1R 160 M8	IE2-WU1R 160 M8	0.0530	86
IE2-AE1R 160 MX8	IE2-AU1R 160 MX8	IE2-AU1R 160 MX8	IE2-WE1R 160 MX8	IE2-WU1R 160 MX8	0.1130	115
IE2-AE2R 160 MX8	IE2-AU2R 160 MX8	IE2-AU2R 160 MX8	IE2-WE2R 160 MX8	IE2-WU2R 160 MX8	0.0530	103
IE2-AE1R 160 L8	IE2-AU1R 160 L8	IE2-AU1R 160 L8	IE2-WE1R 160 L8	IE2-WU1R 160 L8	0.1450	136
IE2-AE1R 180 L8	IE2-AU1R 180 L8	IE2-AU1R 180 L8	IE2-WE1R 180 L8	IE2-WU1R 180 L8	0.2280	175
IE2-AE2R 180 L8	IE2-AU2R 180 L8	IE2-AU2R 180 L8	IE2-WE2R 180 L8	IE2-WU2R 180 L8	0.1660	157
IE2-AE1R 200 L8	IE2-AU1R 200 L8	IE2-AU1R 200 L8	IE2-WE1R 200 L8	IE2-WU1R 200 L8	0.2680	200
IE2-AE1R 225 S8	IE2-AU1R 225 S8	IE2-AU1R 225 S8	IE2-WE1R 225 S8	IE2-WU1R 225 S8	0.440	265
IE2-AE2R 225 S8	IE2-AU2R 225 S8	IE2-AU2R 225 S8	IE2-WE2R 225 S8	IE2-WU2R 225 S8	0.514	305
IE2-AE1R 225 M8	IE2-AU1R 225 M8	IE2-AU1R 225 M8	IE2-WE1R 225 M8	IE2-WU1R 225 M8	0.825	380
IE2-AE2R 225 M8	IE2-AU2R 225 M8	IE2-AU2R 225 M8	IE2-WE2R 225 M8	IE2-WU2R 225 M8	0.514	307
IE2-AE1R 250 M8	IE2-AU1R 250 M8	IE2-AU1R 250 M8	IE2-WE1R 250 M8	IE2-WU1R 250 M8	1.350	480
IE2-AE2R 250 M8	IE2-AU2R 250 M8	IE2-AU2R 250 M8	IE2-WE2R 250 M8	IE2-WU2R 250 M8	0.950	405
IE2-AE1R 280 S8	IE2-AU1R 280 S8	IE2-AU1R 280 S8	IE2-WE1R 280 S8	IE2-WU1R 280 S8	1.55	550
IE2-AE1R 280 M8	IE2-AU1R 280 M8	IE2-AU1R 280 M8	IE2-WE1R 280 M8	IE2-WU1R 280 M8	2.63	690
IE2-AE1R 315 S8	IE2-AU1R 315 S8	IE2-AU1R 315 S8	IE2-WE1R 315 S8	IE2-WU1R 315 S8	2.63	690
IE2-AE1R 315 M8	IE2-AU1R 315 M8	IE2-AU1R 315 M8	IE2-WE1R 315 M8	IE2-WU1R 315 M8	3.6	880
IE2-AE1R 315 MX8	IE2-AU1R 315 MX8	IE2-AU1R 315 MX8	IE2-WE1R 315 MX8	IE2-WU1R 315 MX8	6	1050
IE2-AE1R 315 MY8	IE2-AU1R 315 MY8	IE2-AU1R 315 MY8	IE2-WE1R 315 MY8	IE2-WU1R 315 MY8	6.76	1250
IE2-AE1R 315 L8	IE2-AU1R 315 L8	IE2-AU1R 315 L8	IE2-WE1R 315 L8	IE2-WU1R 315 L8	8.71	1430
IE2-AE1R 315 LX8	IE2-AU1R 315 LX8	IE2-AU1R 315 LX8	IE2-WE1R 315 LX8	IE2-WU1R 315 LX8	8.71	1430
IE2-AE2R 355 M8	IE2-AU2R 355 M8	IE2-AU2R 355 M8	IE2-WE2R 355 M8	IE2-WU2R 355 M8	9.5	1850
IE2-AE2R 355 MX8	IE2-AU2R 355 MX8	IE2-AU2R 355 MX8	IE2-WE2R 355 MX8	IE2-WU2R 355 MX8	13.4	2200
IE2-AE2R 355 LY8	IE2-AU2R 355 LY8	IE2-AU2R 355 LY8	IE2-WE2R 355 LY8	IE2-WU2R 355 LY8	15.8	2400

Overview of technical data

Three-phase roller table motors with squirrel-cage rotor, light-duty version for converter-fed operation, non-ventilated, Type of cooling IC 410

The most important technical data are summarised in the following table. Further information can be taken from the catalogue section "Introduction" (chapter 1).

Product group	Roller table motors, squirrel-cage rotor, IEC/EN
Series	A210, A200
Rated output	0.04 kW to 230 kW
Sizes	56 to 355
Housing material	Grey cast iron EN GJL-200 DIN EN 1561 or optionally spheroidal cast iron EN-GJS 500 to DIN EN 1563 with horizontal/vertical cooling ribs
Rated torque	0.31 Nm to 1795 Nm
Duty types	S7/S9 to IEC/EN 60034-1
Method of connection	Single-speed motors are designed in star-delta configuration as standard. In the case of pole-changing motors, the method of connection is dependent on the combination of pole numbers, see selection lists.
Stator winding insulation	Thermal class 155, optionally 155 [F(B)], 180 to IEC/EN 60034-1
Degree of protection	IP 55 to IEC/EN 60034-5, higher protection ratings possible as options
Type of cooling	IC 410 to IEC/EN 60034-6
Coolant temperature/ installation altitude	Standard -20 °C to +40 °C, Altitude 1000 m above sea level
Rated voltage	Standard voltages to EN 60038 50 Hz: 230 V, 400 V, 500 V, 690 V 60 Hz: 275 V, 460 V, 480 V, 600 V Rated Voltage ranges A and B to IEC/EN 60034-1
Types of construction	IM B3, IM B35, IM B5 and derived types to IEC/EN 60034-7
Paint finish	Normal finish "Moderate", colour RAL 7031, blue-grey Special finish "Worldwide", colour RAL 7031, blue-grey
Vibration severity grade	Grade "A" as standard for machines with no special vibration requirements
Shaft ends	to DIN 748 (IEC 60072), balanced with half-key
Sound pressure level	to DIN EN ISO 1680, tolerance + 3 dB,
Limit speeds	Please refer to the section of "Limit speeds" in catalogue section "Motors for converter-fed operation", Chapter 4.
Bearing design	Please refer to the tables of "Bearing design data" in catalogue section „Standand motors“, Chapter 2.
Motor mass	Please refer to the technical selection lists.
Terminal boxes	Please refer to the section "Terminal boxes" in catalogue section „Standand motors“, Chapter 2.
Documentation	An operating and maintenance manual, a terminal plan and a safety data sheet are supplied with each motor.
Tolerances	Please refer to the section "Tolerances" in catalogue section "Introduction", Chapter 1.
Options	Please refer to the section "Overview of modifications" in catalogue section "Introduction", Chapter 1.

Motor selection data

Three-phase roller table motors with squirrel-cage rotor light-duty version, for use on a frequency converter

Type of cooling IC 410, non-ventilated version, duty type S7/S9
Thermal class 155, degree of protection IP 55, coolant temperature +50 °C

Motor selection data												Design point 400 V, 50 Hz	
Type		P_B	M_B	n_B	η_B	$\cos\varphi_B$	I_B	I_R/I_B	M_R/M_B	M_S/M_B	M_K/M_B	J	m
		IEC/EN 60034-2					400 V	-	-	-	-	kgm ²	kg
		kW	Nm	rpm	%	-	A	-	-	-	-	-	-
Synchronous speed 3000 rpm – 2-pole version													
A210 63 A2U	A200 56 A2U	0.09	0.31	2815	66.6	0.79	0.25	4.8	2.5	2.3	2.9	0.00013	4.8
A210 63 G2U	A200 56 G2U	0.12	0.40	2855	64.8	0.74	0.36	5.1	2.8	2.7	3.0	0.00015	5.1
A210 71 A2U	A200 63 A2U	0.18	0.61	2810	71.4	0.87	0.42	8.5	3.6	3.6	3.9	0.00025	6.5
A210 71 G2U	A200 63 G2U	0.25	0.84	2860	79.1	0.80	0.57	6.5	2.7	2.7	3.1	0.00032	7.4
A210 80 A2U	A200 71 A2U	0.37	1.24	2850	79.8	0.87	0.77	6.4	2.8	2.2	2.4	0.00057	10.4
A210 80 G2U	A200 71 G2U	0.55	1.84	2850	79.6	0.89	1.12	7.2	2.7	2.4	2.6	0.00072	11.2
A210 90 S2U	A200 80 A2U	0.75	2.49	2880	79.9	0.88	1.54	8.8	3.4	3.2	3.5	0.00132	15.7
A210 90 L2U	A200 80 G2U	1.10	3.69	2850	81.6	0.89	2.2	7.6	2.6	2.6	2.7	0.0017	18.7
A210 100 L2U	A200 90 L2U	1.40	4.58	2920	84.7	0.86	2.8	10.5	3.5	3.4	4.0	0.00275	24.5
A210 112 M2U	A200 100 S2U	2.05	6.68	2930	87.3	0.82	4.1	9.3	2.6	2.5	3.7	0.0045	31.4
A210 112 MX2U	A200 100 L2U	2.8	9.11	2935	89.4	0.85	5.3	10.8	3.0	2.6	4.1	0.0055	37.4
A210 132 SX2	A200 112 M2	3.0	9.90	2895	89.5	0.91	5.7	7.4	2.0		2.8	0.0110	57
A210 160 M2	A200 132 M2	4	13.2	2900	91.0	0.94	7.2	7.3	1.7		2.9	0.0258	81
A210 160 MX2	A200 160 S2	5.5	17.9	2935	91.5	0.93	9.9	7.8	1.9		2.9	0.0575	118
A210 160 L2	A200 160 M2	7.5	24.4	2935	92.5	0.93	13.2	8.1	2.1		3.0	0.0675	134
A210 180 M2	A200 180 S2	8.8	28.6	2935	92.5	0.93	19.3	7.7	2.0		2.6	0.105	165
A210 200 L2	A200 180 M2	12	39.0	2940	93.5	0.93	21.0	8.1	2.0		2.7	0.128	195
A210 200 LX2	A200 200 M2	15	48.6	2945	92.5	0.92	25.5	7.7	1.7		2.5	0.193	255
A210 225 M2	A200 200 L2	18.5	60.0	2945	93.0	0.92	31	8.0	1.8		2.6	0.220	290
A210 250 M2	A200 225 M2	22	71.1	2955	93.5	0.92	37	8.1	1.9		2.6	0.375	360
A210 280 S2	A200 250 S2	32	103	2965	93.5	0.93	53	8.9	1.9		2.7	0.650	490
A210 280 M2	A200 250 M2	40	129	2965	94.0	0.93	66	9.0	1.9		2.7	0.675	510
A210 315 S2	A200 280 S2	49	158	2970	94.0	0.93	81	8.8	1.6		2.7	1.21	720
A210 315 M2	A200 280 M2	59	190	2970	94.5	0.93	97	9.2	1.7		2.8	1.44	800
A210 315 MX2	A200 315 S2	70	225	2970	95.0	0.94	114	9.6	1.9		2.7	1.76	980
A210 315 MY2	A200 315 M2	90	289	2975	95.5	0.94	145	8.7	2.0		2.7	2.82	1170
A210 315 L2	A200 315 L2	120	385	2980	96.0	0.94	192	9.7	2.5		2.7	3.66	1460
A210 315 LX2	A200 315 LX2	145	465	2980	96.0	0.94	232	9.7	2.7		2.7	4.43	1630
A220 355 MY2		145	464	2985								4.10	1900
A220 355 M2		160	512	2985								4.20	2000
A220 355 MX2		180	576	2985								5.5	2200
A220 355 LY2		200	640	2985								7.1	2400
A220 355 L2		230	736	2985								7.1	2400
Synchronous speed 1500 rpm – 4-pole version													
A210 63 K4U	A200 56 K4U	0.06	0.41	1400	57.6	0.66	0.23	3.2	2.1	2.1	2.4	0.00019	4.7
A210 63 G4U	A200 56 G4U	0.09	0.62	1395	61.8	0.67	0.31	3.7	2.5	2.5	2.7	0.00024	5.1
A210 71 K4U	A200 63 K4U	0.12	0.82	1400	64.9	0.72	0.37	4.0	2.0	2.0	2.4	0.00040	6.6
A210 71 G4U	A200 63 G4U	0.18	1.24	1390	67.9	0.76	0.5	4.4	2.3	2.3	2.5	0.00050	7.6
A210 80 K4U	A200 71 K4U	0.25	1.68	1425	70.5	0.77	0.67	5.5	2.4	2.2	2.6	0.00087	10.3
A210 80 G4U	A200 71 G4U	0.37	2.50	1415	75.9	0.78	0.9	6.0	2.7	2.3	2.7	0.00107	11.4
A210 90 S4U	A200 80 K4U	0.55	3.69	1425	78.4	0.79	1.28	6.2	2.5	2.0	2.7	0.00207	15.2
A210 90 L4U	A200 80 G4U	0.75	5.04	1420	79.4	0.82	1.66	6.5	2.7	2.7	2.9	0.00260	17.7
A210 100 L4U	A200 90 L4U	1.0	6.63	1440	82.1	0.74	2.4	8.3	3.8	3.6	4.2	0.00400	23.0
A210 100 LX4U	A200 100 S4U	1.5	9.88	1450	83.5	0.78	3.3	8.3	2.9	2.9	3.7	0.00725	29.4
A210 112 M4U	A200 100 L4U	2.0	13.1	1455	86.0	0.76	4.4	8.9	3.2	3.2	4.2	0.00900	36.4
A210 132 S4	A200 112 M4	2.3	15.3	1440	88.0	0.87	4.6	7.5	2.5		3.0	0.015	50
A210 132 M4	A200 132 S4	3.0	19.8	1445	89.0	0.86	5.9	6.6	2.2		2.3	0.028	69
A210 160 M4	A200 132 M4	4.4	28.9	1455	90.0	0.86	8.4	7.0	2.0		2.8	0.035	86
A210 160 L4	A200 160 S4	5.5	35.9	1465	91.5	0.89	10.4	7.7	2.5		3.0	0.078	120
A210 180 M4	A200 160 M4	8.0	52.2	1465	92.0	0.89	14.8	7.5	2.4		2.9	0.090	136
A210 180 L4	A200 180 S4	8.8	57.2	1470	93.0	0.89	16.1	8.5	2.4		2.9	0.138	170
A210 200 L4	A200 180 M4	11.0	71.5	1470	93.0	0.88	20.2	8.5	2.5		2.9	0.168	200
A210 225 S4	A200 200 M4	15.0	97.2	1475	92.5	0.88	26.5	7.8	2.0		2.4	0.275	270
A210 225 M4	A200 200 L4	18.5	120	1475	92.5	0.88	33.0	7.6	2.0		2.4	0.313	300
A210 250 M4	A200 225 M4	22	142	1475	93.0	0.89	38.5	7.7	2.1		2.5	0.525	375
A210 280 S4	A200 250 S4	32	207	1480	93.5	0.89	56.0	8.2	2.3		2.5	0.95	520
A210 280 M4	A200 250 M4	40	258	1480	94.0	0.89	69.5	8.5	2.5		2.5	1.10	580
A210 315 S4	A200 280 S4	50	323	1480	94.0	0.89	86.0	8.9	2.3		2.5	1.96	740
A210 315 M4	A200 280 M4	60	387	1480	94.5	0.89	103.0	9.1	2.4		2.6	2.27	840
A210 315 MX4	A200 315 S4	70	452	1480	94.5	0.89	121.0	9.9	2.7		2.8	2.73	1000
A210 315 MY4	A200 315 M4	95	611	1485	96.0	0.91	158.0	9.0	2.3		2.5	4.82	1200
A210 315 L4	A200 315 L4	132	849	1485	96.0	0.91	219.0	9.1	2.4		2.6	5.93	1450
A210 315 LX4	A200 315 LX4	150	966	1485	96.0	0.90	252.0	10.0	2.8		2.9	6.82	1630
A220 355 MY4		150	961	1490								5.6	1950
A220 355 LY4		160	1029	1485								10.0	2500
A220 355 L4		180	1158	1485								10.0	2500

**Three-phase roller table motors with squirrel-cage rotor
light-duty version, for use on a frequency converter**

Type of cooling IC 410, non-ventilated version, duty type S7/S9
Thermal class 155, degree of protection IP 55, coolant temperature +50 °C

Motor selection data												Design point 400 V, 50 Hz	
Type		P _B	M _B	n _B	η _B	cosφ _B	I _B	I _x /I _B	M _x /M _B	M _s /M _B	M _k /M _B	J	m
		kW	Nm	rpm	IEC/EN 60034-2 %	-	400 V A	-	-	-	-	kgm ²	kg
Synchronous speed 1000 rpm – 6-pole version													
A210 63 K6U	A200 56 K6U	0.04	0.42	920	48.7	0.52	0.23	2.5	2.1	2.1	2.6	0.00024	4.8
A210 63 G6U	A200 56 G6U	0.06	0.63	905	52.5	0.56	0.29	2.5	2.0	2.0	2.3	0.00027	5.6
A210 71 K6U	A200 63 K6U	0.09	0.91	940	59.5	0.50	0.44	3.2	2.1	2.1	2.6	0.00045	7.2
A210 71 G6U	A200 63 G6U	0.12	1.25	920	58.2	0.55	0.54	3.0	2.0	2.0	2.4	0.00060	8.1
A210 80 K6U	A200 71 K6U	0.18	1.83	940	62.8	0.66	0.63	4.3	2.3	2.3	2.8	0.00130	10.7
A210 80 G6U	A200 71 G6U	0.25	2.53	945	69.2	0.61	0.86	4.6	2.9	2.9	3.1	0.00175	12.2
A210 90 S6U	A200 80 K6U	0.37	3.76	940	72.3	0.67	1.1	4.8	2.0	2.0	2.5	0.00325	15.7
A210 90 L6U	A200 80 G6U	0.55	5.59	940	74.6	0.70	1.52	4.6	2.0	2.0	2.4	0.00425	18.7
A210 100 L6U	A200 90 L6U	0.75	7.46	960	78.5	0.66	2.1	5.1	2.3	2.3	2.7	0.00625	23.5
A210 112 M6U	A200 100 L6U	1.1	10.9	960	78.9	0.73	2.8	6.6	2.6	2.5	3.5	0.01225	32.9
A210 132 S6	A200 112 M6	1.5	14.9	960	82.5	0.78	3.5	7.0	2.9		3.6	0.018	46
A210 132 M6	A200 112 MX6	1.9	18.9	960	84.5	0.79	4.3	7.7	3.4		3.7	0.023	53
A210 132 MX6	A200 132 S6	2.6	25.9	960	86.0	0.85	5.4	6.5	2.7		2.8	0.043	70
A210 160 M6	A200 132 M6	3.5	34.8	960	87.0	0.84	7.1	7.2	3.1		3.2	0.053	86
A210 160 L6	A200 160 S6	4.8	47.5	965	89.0	0.88	9.1	7.4	2.7		3.0	0.113	114
A210 180 L6	A200 160 M6	6.5	64.0	970	90.0	0.88	12.3	7.8	3.0		3.2	0.145	136
A210 200 L6	A200 180 S6	7.6	74.4	975	91.0	0.88	14.3	7.5	2.4		3.2	0.228	175
A210 200 LX6	A200 180 M6	9.5	93.1	975	91.0	0.92	17.1	7.7	2.4		3.2	0.268	200
A210 225 M6	A200 200 M6	12.5	123	970	90.5	0.90	22.0	6.5	1.9		2.5	0.443	265
A210 250 M6	A200 225 M6	16.5	162	975	91.5	0.89	29.5	6.8	2.0		2.6	0.825	360
A210 280 S6	A200 250 S6	22	214	980	92.0	0.88	39.5	6.6	2.0		2.4	1.28	465
A210 280 M6	A200 250 M6	27	263	980	92.5	0.88	48.0	7.1	2.2		2.6	1.48	520
A210 315 S6	A200 280 S6	37	359	985	93.0	0.89	65.0	7.4	2.0		2.4	2.63	690
A210 315 M6	A200 280 M6	44	427	985	93.5	0.89	76.5	7.8	2.2		2.5	3.33	800
A210 315 MX6	A200 315 S6	48	465	985	93.5	0.89	84.0	8.6	2.5		2.7	3.60	880
A210 315 MY6	A200 315 M6	75	727	985	94.0	0.89	130.0	8.0	2.2		2.5	6.00	1050
A210 315 L6	A200 315 L6	90	873	985	95.0	0.90	153.0	7.9	2.2		2.4	6.67	1250
A210 315 LX6	A200 315 LX6	110	1067	985	95.0	0.90	187.0	8.6	2.4		2.6	8.60	1460
A220 355 MY6		110	1056	995								8.1	1550
A220 355 M6		140	1344	995								8.2	1650
A220 355 MX6		160	1536	995								12.1	2200
A220 355 LY6		170	1632	995								14.0	2400
Synchronous speed 750 rpm – 8-pole version													
A210 71 K8U	A200 63 K8U	0.04	0.55	695	40.2	0.54	0.27	2.3	2.2	2.2	2.7	0.00050	6.4
A210 71 G8U	A200 63 G8U	0.06	0.84	680	42.2	0.54	0.38	2.3	2.3	2.3	2.6	0.00060	7.9
A210 80 K8U	A200 71 K8U	0.09	1.22	705	49.5	0.60	0.44	3.0	2.0	2.0	2.6	0.00130	10.2
A210 80 G8U	A200 71 G8U	0.12	1.63	705	53.3	0.57	0.57	3.3	2.5	2.5	3.0	0.00175	11.7
A210 90 S8U	A200 80 K8U	0.18	2.44	705	60.5	0.58	0.74	3.3	1.9	1.9	2.2	0.00300	14.7
A210 90 L8U	A200 80 G8U	0.25	3.39	705	67.8	0.56	0.95	3.5	2.0	2.0	2.4	0.00375	17.7
A210 100 L8U	A200 90 L8U	0.37	4.98	710	62.5	0.60	1.43	3.2	1.7	1.7	2.1	0.00625	22.5
A210 100 LX8U	A200 100 S8U	0.55	7.40	710	72.9	0.63	1.73	4.5	2.5	2.5	2.7	0.00900	27.4
A210 112 M8U	A200 100 L8U	0.75	10.1	710	75.1	0.69	2.1	4.5	2.2	2.2	2.8	0.01225	32.9
A210 132 S8	A200 112 M8	1.1	14.6	720	77.5	0.66	3.3	5.5	2.8		3.5	0.018	46
A210 132 M8	A200 112 MX8	1.5	20.0	715	79.5	0.70	4.1	5.3	2.6		3.1	0.023	53
A210 160 M8	A200 132 S8	1.8	23.9	720	83.5	0.72	4.5	5.3	2.6		3.0	0.043	70
A210 160 MX8	A200 132 M8	2.5	33.2	720	84.0	0.74	6.0	5.0	2.3		2.7	0.053	86
A210 160 L8	A200 160 S8	3.6	47.4	725	86.5	0.79	8.0	5.4	2.3		2.9	0.113	114
A210 180 L8	A200 160 M8	5.0	65.9	725	87.5	0.79	11.0	5.5	2.3		2.8	0.145	136
A210 200 L8	A200 180 S8	6.5	85.6	725	89.0	0.81	13.8	6.1	2.2		2.8	0.228	175
A210 225 S8	A200 180 M8	7.5	98.1	730	89.5	0.80	15.9	6.5	2.4		3.0	0.440	265
A210 225 M8	A200 200 M8	9.0	118	730	90.0	0.81	18.0	5.9	1.8		2.6	0.440	265
A210 250 M8	A200 225 M8	13.0	169	735	90.0	0.81	26.0	5.9	1.9		2.5	0.825	360
A210 280 S8	A200 250 S8	17.5	227	735	91.0	0.76	36.5	6.1	2.0		2.7	1.35	465
A210 280 M8	A200 250 M8	22	286	735	91.0	0.76	46.0	6.3	2.1		2.8	1.55	520
A210 315 S8	A200 280 S8	28	364	735	92.0	0.79	55.5	6.8	2.1		2.4	2.63	690
A210 315 M8	A200 280 M8	35	452	740	92.0	0.80	68.5	6.8	2.1		2.4	3.33	800
A210 315 MX8	A200 315 S8	37	478	740	92.5	0.80	72.5	7.2	2.2		2.6	3.60	880
A210 315 MY8	A200 315 M8	55	710	740	93.0	0.82	104.0	7.3	2.1		2.4	6.00	1050
A210 315 L8	A200 315 L8	68	878	740	93.5	0.82	128.0	7.6	2.2		2.5	6.76	1250
A210 315 LX8	A200 315 LX8	85	1097	740	94.0	0.82	159.0	7.7	2.3		2.5	8.6	1430
A220 355 MY8		85	1097	740								9.3	1500
A220 355 M8		90	1154	745								9.5	1600
A220 355 MX8		110	1410	745								13.4	2200
A220 355 LY8		140	1795	745								15.8	2400

Bearings and Connection system

Die Three-phase roller table motors Series A..0 are identical to series Standard motors K21R
For further information regarding the connection system and bearings, please refer to Chapter 2.

Dimensions

Notes concerning dimensions

Dimension designations in accordance with EN 50347 and IEC 60072

Flange sizes in the dimension tables are specified in accordance with DIN 42948.

VEM motors GmbH reserves the right to modify technical data without prior notice. The dimensions shown in catalogues may not be up to date. Binding dimensional data can be requested from the VEM sales organisation.

All dimensions in mm

Flange dimensions

Flanges with threaded holes

Flange type to E DIN EN 50347	Flange type to DIN 42948	LA c ₁	M e ₁	N b ₁	P a ₁	S s ₁	T f ₁
FT 65	C 80	6.5	65	50	80	M5	2.5
FT 75	C 90	8	75	60	90	M5	2.5
FT 85	C 105	8.5	85	70	105	M6	2.5
FT 100	C 120	8	100	80	120	M6	3
FT 115	C 140	10	115	95	140	M8	3
FT 130	C 160	10	130	110	160	M8	3.5
FT 165	C 200	12	165	130	200	M10	3.5
FT 215	C 250	12	215	180	250	M12	4

Flanges with through-holes

Flange type to E DIN EN 50 347	Flange type to DIN 42948	LA c ₁	M e ₁	N b ₁	P a ₁	S s ₁	T f ₁
FF 100	A 120	9	100	80	120	7	3
FF 115	A 140	9	115	95	140	9	3
FF 130	A 160	9	130	110	160	9	3.5
FF 165	A 200	10	165	130	200	11	3.5
FF 215	A 250	11	215	180	250	14	4
FF 265	A 300	12	265	230	300	14	4
FF 300	A 350	13	300	250	350	18	5
FF 350	A 400	15	350	300	400	18	5
FF 400	A 450	16	400	350	450	18	5
FF 500	A 550	18	500	450	550	18	5
FF 600	A 660	22	600	550	660	22	6
FF 740	A 800	25	740	680	800	22	6
FF 940	A1000	25	940	880	1000	28	6
FF 1080	A1150	32	1080	1000	1150	28	6

According to DIN EN 50347, the different sizes of FF flanges possess through-holes, while FT flanges possess threaded holes.
The flange designations A and C defined in DIN 42948 remain valid.

Flange assignments which deviate from the standard are specified in the flange assignment tables.

For tolerances for the dimension N (b₁), refer to the corresponding dimension tables LA (c₁) depth of engagement

Three-phase roller table motors with squirrel-cage rotor, transnorm light-duty version, for use on a frequency converter

Type of cooling IC 410, non-ventilated version
 Sizes 56 to 280

Type of construction IM B3 [IM 1001]

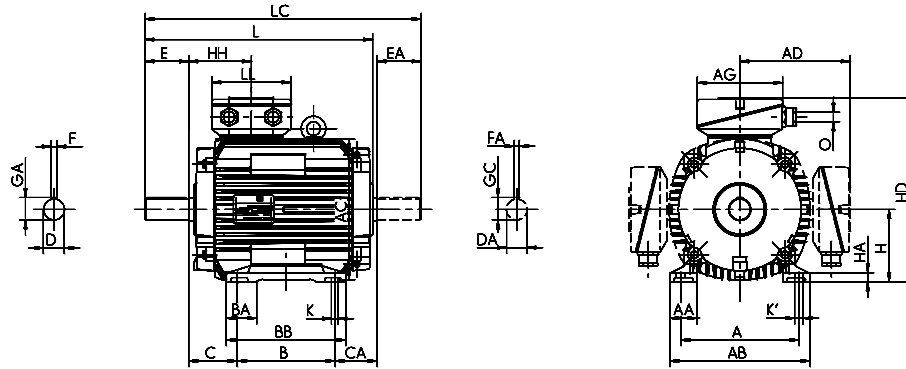

Type designation	Flange size	A	AA	AB	AC	AD	B	BA	BB	C	CA	D	DA	DB ^{*)}	E	EA	F	FA
		b	n	f	g	g1	a	m	e	w1	w2	d	d1		l	l1	u	u1
A210 63 K2, 4, 6 U	FF115	100	28	128	109	98	80	-	100	40	-	11	11	M4	23	23	4	4
A210 63 G2, 4, 6 U	FF115	100	28	128	109	98	80	-	100	40	-	11	11	M4	23	23	4	4
A210 71 K2, 4, 6, 8 U	FF130	112	32	138	124	104	90	-	116	45	-	14	14	M5	30	30	5	5
A210 71 G2, 4, 6, 8	FF130	112	32	138	124	104	90	-	116	45	-	14	14	M5	30	30	5	5
A210 80 K2, 4, 6, 8 U	FF 165	125	38	168	139	111	100	-	125	50	-	19	19	M6	40	40	6	6
A210 80 G2, 4, 6, 8 U	FF 165	125	38	168	139	111	100	-	125	50	-	19	19	M6	40	40	6	6
A210 90 S2, 4, 6, 8 U	FF 165	140	40	178	157	119	100	-	130	56	-	24	22	M8	50	50	8	6
A210 90 L2, 4, 6, 8 U	FF 165	140	40	178	157	119	125	-	155	56	-	24	22	M8	50	50	8	6
A210 100 L2, 4, 6, 8 U	FF 215	160	45	192	177	126	140	-	175	63	-	28	24	M10	60	50	8	8
A210 100 LX4, 8 U	FF 215	160	32	188	196	136	140	-	171	63	-	28	28	M10	60	60	8	8
A210 112 M2 U	FF 215	190	50	224	196	136	140	-	180	70	-	28	28	M10	60	60	8	8
A210 112 M6, 8 U	FF 215	190	50	224	196	136	140	-	180	70	-	28	28	M10	60	60	8	8
A210 112 MX2 U	FF 215	190	50	224	196	136	140	-	180	70	-	28	28	M10	60	60	8	8
A210 112 M4 U	FF 215	190	50	224	196	136	140	-	180	70	-	28	28	M10	60	60	8	8
A210 132 S2T U	FF265	216	50	256	196	155	140	-	180	89	-	38	28	M12	80	60	10	8
A210 132 S4T U	FF265	216	50	256	196	155	140	-	180	89	-	38	28	M12	80	60	10	8
A210 132 S2	FF265	216	50	256	217	178	140	55	180	89	97	38	32	M12	80	80	10	10
A210 132 SX2	FF265	216	50	256	217	178	140	55	180	89	117	38	32	M12	80	80	10	10
A210 132 S4, 6, 8	FF265	216	50	256	217	178	140	55	180	89	97	38	32	M12	80	80	10	10
A210 132 M4	FF265	216	50	256	258	199	178	55	218	89	79	38	38	M12	80	80	10	10
A210 132 MX6	FF265	216	50	256	258	199	178	55	218	89	79	38	38	M12	80	80	10	10
A210 132 M6, 8	FF265	216	50	256	217	178	178	55	218	89	79	38	32	M12	80	80	10	10
A210 160 M2	FF300	254	55	296	258	214	210	60	257	108	76	42	38	M16	110	80	12	10
A210 160 M4, 6, 8	FF300	254	55	296	258	214	210	60	257	108	76	42	38	M16	110	80	12	10
A210 160 MX8	FF300	254	55	296	258	199	210	60	257	108	76	42	38	M16	110	80	12	10
A210 160 MX2	FF300	254	55	296	313	242	210	60	257	108	87	42	42	M16	110	110	12	12
A210 160 L2, 4, 6, 8	FF300	254	55	296	313	242	254	60	301	108	81	42	42	M16	110	110	12	12
A210 180 M2	FF300	279	62	328	351	261	241	65	288	121	107	48	48	M16	110	110	14	14
A210 180 M4	FF300	279	62	328	313	242	241	65	288	121	81	48	42	M16	110	110	14	12
A210 180 L4	FF300	279	62	328	351	261	279	65	326	121	114	48	48	M16	110	110	14	14
A210 180 L6, 8	FF300	279	62	328	313	242	279	65	326	121	43	48	42	M16	110	110	14	12
A210 200 L2, 4, 6, 8	FF 350	318	70	372	351	261	305	70	360	133	76	55	48	M20	110	110	16	14
A210 200 LX6	FF 350	318	70	372	351	261	305	70	360	133	76	55	48	M20	110	110	16	14
A210 200 LX2	FF 350	318	70	372	390	300	305	70	360	133	139	55	55	M20	110	110	16	16
A210 225 S4, 8	FF 400	356	75	413	390	300	286	75	343	149	148	60	55	M20	140	110	18	16
A210 225 M2	FF 400	356	75	413	390	300	311	75	368	149	157	55	55	M20	110	110	16	16
A210 225 M4	FF 400	356	75	413	390	300	311	75	368	149	157	60	55	M20	140	110	18	16
A210 225 M6, 8	FF 400	356	75	413	390	300	311	75	368	149	117	60	55	M20	140	110	18	16
A210 250 M2	FF 500	406	84	471	440	358	349	84	412	168	90	60	55	M20	140	110	18	16
A210 250 M4, 6, 8	FF 500	406	84	471	440	358	349	84	412	168	90	65	55	M20	140	110	18	16
A210 280 S2	FF 500	457	94	522	490	386	368	96	431	190	113	65	65	M20	140	140	18	18
A210 280 S4, 6, 8	FF 500	457	94	522	490	386	368	96	431	190	113	75	65	M20	140	140	20	18
A210 280 M2	FF 500	457	94	522	490	386	419	96	482	190	108	65	65	M20	140	140	18	18
A210 280 M4, 6, 8	FF 500	457	94	522	490	386	419	96	482	190	108	75	65	M20	140	140	20	18

^{*)} Centre holes to DIN 332-DS

Three-phase roller table motors with squirrel-cage rotor, transnorm light-duty version, for use on a frequency converter

Type of cooling IC 410, non-ventilated version
 Sizes 56 to 280

Type of construction IM B3 [IM 1001]

Flange dimensions, see page 9/23

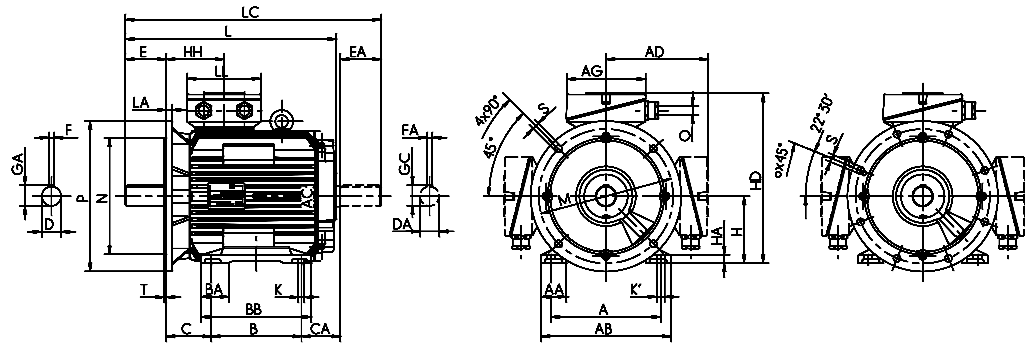

Type designation	GA	GC	H	HA	HD	HD ^{*)}	HH	K	K'	L	LC	TB Type	AG	LL	O	Hole pattern
	t	t1	h	c	p	p	A	s	s'	k	k1		x	z	-	
A210 63 K2, 4, 6 U	12.5	12.5	63	10	161	***)	58	8	8	155	***)	KA 05	92	92	M20 x 1.5	4L
A210 63 G2, 4, 6 U	12.5	12.5	63	10	161	***)	58	8	8	155	***)	KA 05	92	92	M20 x 1.5	4L
A210 71 K2, 4, 6, 8 U	16	16	71	11	175	***)	61	8	8	177	***)	KA 05	92	92	M20 x 1.5	4L
A210 71 G2, 4, 6, 8	16	16	71	11	175	***)	61	8	8	177	***)	KA 05	92	92	M20 x 1.5	4L
A210 80 K2, 4, 6, 8 U	21.5	21.5	80	12	191	***)	67	10	10	217	***)	KA 05	92	92	M20 x 1.5	4L
A210 80 G2, 4, 6, 8 U	21.5	21.5	80	12	191	***)	67	10	10	217	***)	KA 05	92	92	M20 x 1.5	4L
A210 90 S2, 4, 6, 8 U	27	24.5	90	14	210	***)	70	10	10	241	***)	KA 05	92	92	M25 x 1.5	4L
A210 90 L2, 4, 6, 8 U	27	24.5	90	14	210	***)	70	10	10	263	***)	KA 05	92	92	M25 x 1.5	4L
A210 100 L2, 4, 6, 8 U	31	27	100	15	227	***)	75	12	12	289	***)	KA 05	92	92	M25 x 1.5	4L
A210 100 LX4, 8 U	31	31	100	11	237	***)	77	12	12	314	***)	KA 05	92	92	M25 x 1.5	4L
A210 112 M2 U	31	31	112	18	249	***)	77	12	12	314	***)	KA 05	92	92	M25 x 1.5	4L
A210 112 M6, 8 U	31	31	112	18	249	***)	77	12	12	314	***)	KA 05	92	92	M25 x 1.5	4L
A210 112 MX2 U	31	31	112	18	249	***)	77	12	12	348	***)	KA 05	92	92	M25 x 1.5	4L
A210 112 M4 U	31	31	112	18	249	***)	77	12	12	348	***)	KA 05	92	92	M25 x 1.5	4L
A210 132 S2T U	41	31	132	18	287	***)	105	12	12	387	***)	KA 05-13	104	112	M32 x 1.5	4L
A210 132 S4T U	41	31	132	18	287	***)	105	12	12	417	***)	KA 05-13	104	112	M32 x 1.5	4L
A210 132 S2	41	35	132	16	310	257	108	12	12	397	486	25 A	156	145	M32 x 1.5	4L
A210 132 SX2	41	35	132	16	310	257	108	12	12	417	506	25 A	156	145	M32 x 1.5	4L
A210 132 S4, 6, 8	41	35	132	16	310	257	108	12	12	397	486	25 A	156	145	M32 x 1.5	4L
A210 132 M4	41	41	132	16	331	279	114	12	12	420	506	25 A	156	145	M32 x 1.5	4L
A210 132 MX6	41	41	132	16	331	279	114	12	12	420	506	25 A	156	145	M32 x 1.5	4L
A210 132 M6, 8	41	35	132	16	310	257	108	12	12	417	506	25 A	156	145	M32 x 1.5	4L
A210 160 M2	45	41	160	18	374	307	114	15	15	498	584	63 A	193	167	M40 x 1.5	4L
A210 160 M4, 6, 8	45	41	160	18	374	307	114	15	15	498	584	63 A	193	167	M40 x 1.5	4L
A210 160 MX8	45	41	160	18	374	307	114	15	15	498	584	63 A	193	167	M40 x 1.5	4L
A210 160 MX2	45	45	160	18	402	336	138	15	20	502	625	63 A	193	167	M40 x 1.5	4L
A210 160 L2, 4, 6, 8	45	45	160	18	402	336	138	15	20	540	663	63 A	193	167	M40 x 1.5	4L
A210 180 M2	51.5	51.5	180	20	441	369	147	15	20	562	689	63 A	193	167	M40 x 1.5	4L
A210 180 M4	51.5	45	180	20	422	356	138	15	20	540	663	63 A	193	167	M40 x 1.5	4L
A210 180 L4	51.5	51.5	180	20	441	369	147	15	20	607	734	63 A	193	167	M40 x 1.5	4L
A210 180 L6, 8	51.5	45	180	20	422	369	138	15	20	540	663	63 A	193	167	M40 x 1.5	4L
A210 200 L2, 4, 6, 8	59	51.5	200	22	461	389	147	19	25	607	734	63 A	193	167	M40 x 1.5	4L
A210 200 LX6	59	51.5	200	22	461	389	147	19	25	607	734	63 A	193	167	M40 x 1.5	4L
A210 200 LX2	59	59	200	22	500	417	168	19	25	661	797	100 A	213	207	M50 x 1.5	4L
A210 225 S4, 8	64	59	225	25	525	442	168	19	25	691	827	100 A	213	207	M50 x 1.5	8L
A210 225 M2	59	59	225	25	525	442	168	19	25	701	837	100 A	213	207	M50 x 1.5	8L
A210 225 M4	64	59	225	25	525	442	168	19	25	731	867	100 A	213	207	M50 x 1.5	8L
A210 225 M6, 8	64	59	225	25	525	442	168	19	25	691	827	100 A	213	207	M50 x 1.5	8L
A210 250 M2	64	59	250	28	608	484	177	24	30	737	857	200 A	282	242	M63 x 1.5	8L
A210 250 M4, 6, 8	69	59	250	28	608	484	177	24	30	737	857	200 A	282	242	M63 x 1.5	8L
A210 280 S2	69	69	280	32	666	546	206	24	30	801	951	200 A	282	242	M63 x 1.5	8L
A210 280 S4, 6, 8	79.5	69	280	32	666	546	206	24	30	801	951	200 A	282	242	M63 x 1.5	8L
A210 280 M2	69	69	280	32	666	546	206	24	30	847	997	200 A	282	242	M63 x 1.5	8L
A210 280 M4, 6, 8	79.5	69	280	32	666	546	206	24	30	847	997	200 A	282	242	M63 x 1.5	8L

*) Terminal box left/right
 **) upon request

Three-phase roller table motors with squirrel-cage rotor, transnorm light-duty version, for use on a frequency converter

Type of cooling IC 410, non-ventilated version
Size 315

Type of construction IM B3 [IM 1001]

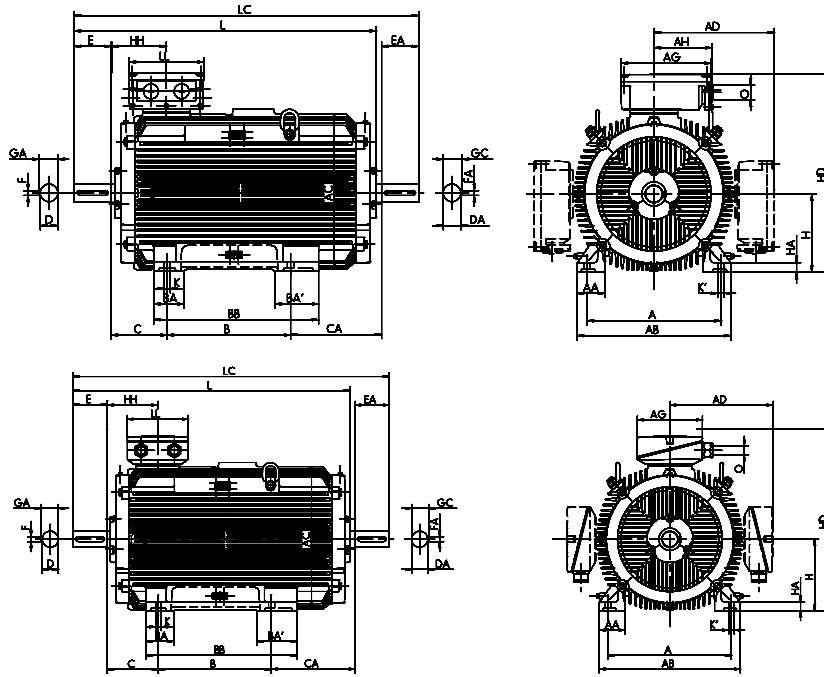

Type designation	Flange size	A	AA	AB	AC	AD	B	BA	BA'	BB	C	CA	D	DA	DB ¹⁾	E	EA	F	FA
		b	n	f	g	g1	a	m	m1	e	w1	w2	d	d1		l	l1	u	u1
A210 315 S2	FF 600	508	126	590	550	416	406	120	-	503	216	126	65	65	M20	140	140	18	18
A210 315 S4, 6, 8	FF 600	508	126	590	550	416	406	120	-	503	216	126	80	70	M20	170	140	22	20
A210 315 M2	FF 600	508	126	590	550	416	457	120	-	554	216	130	65	65	M20	140	140	18	18
A210 315 M4, 6, 8	FF 600	508	126	590	550	416	457	120	-	554	216	130	80	70	M20	170	140	22	20
A210 315 MX2	FF 600	508	126	590	550	416	457	120	150	554	216	208	65	65	M20	140	140	18	18
A210 315 MX4	FF 600	508	126	590	550	416	457	120	150	554	216	208	80	70	M20	170	140	22	20
A210 315 MX6, 8	FF 600	508	126	590	550	416	457	120	150	554	216	128	80	70	M20	170	140	22	20
A210 315 MX10, 12	FF 600	508	126	590	550	416	457	120	150	554	216	128	80	70	M20	170	140	22	20
A210 315 MY2	FF 600	508	110	590	610	494	457	120	-	573	216	307	65	65	M20	140	140	18	18
A210 315 MY4, 6, 8	FF 600	508	110	590	610	494	457	120	-	573	216	307	80	70	M20	170	140	22	20
A210 315 L2	FF 600	508	110	590	610	494	508	120	-	624	216	376	65	65	M20	140	140	18	18
A210 315 L4, 6, 8	FF 600	508	110	590	610	494	508	120	-	624	216	376	80	70	M20	170	140	22	20
A210 315 LX2	FF 600	508	110	590	610	494	508	120	-	624	216	496	65	65	M20	140	140	18	18
A210 315 LX4	FF 600	508	110	590	610	494	508	120	-	624	216	496	80	70	M20	170	140	22	20
A210 315 LX6, 8	FF 600	508	110	590	610	494	508	120	-	624	216	376	80	70	M20	170	140	22	20

¹⁾ Centre holes to DIN 332-DS

Three-phase roller table motors with squirrel-cage rotor, transnorm light-duty version, for use on a frequency converter

Type of cooling IC 410, non-ventilated version
Size 315

Type of construction IM B35 [IM 2001]

Flange dimensions, see page 9/23

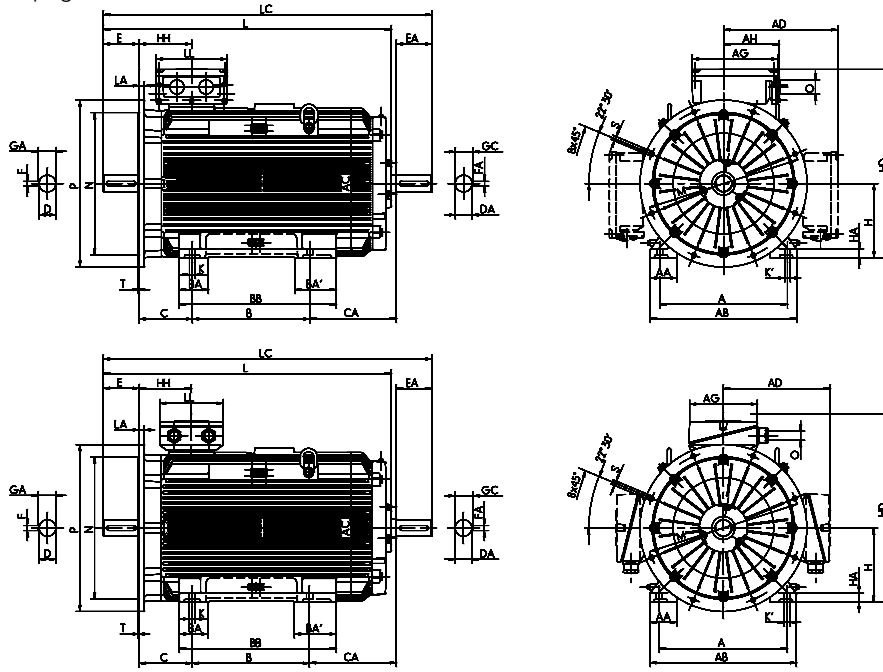

Type designation	GA	GC	H	HA	HD	HD ⁽¹⁾	HH	K	K'	L	LC	TB Type	AG	LL	AH	0
	t	t1	h	c	p	p	A	s	s'	k	k1					
A210 315 S2	69	69	315	44	731	595	211	28	35	879	1026	200 A	282	242	-	M63 x 1.5
A210 315 S4, 6, 8	85	74.5	315	44	731	595	211	28	35	909	1056	200 A	282	242	-	M63 x 1.5
A210 315 M2	69	69	315	44	731	595	211	28	35	934	1081	200 A	282	242	-	M63 x 1.5
A210 315 M4, 6, 8	85	74.5	315	44	731	595	211	28	35	964	1111	200 A	282	242	-	M63 x 1.5
A210 315 MX2	69	69	315	44	731	595	211	28	35	1014	1161	200 A	282	242	-	M63 x 1.5
A210 315 MX4	85	74.5	315	44	731	595	211	28	35	1044	1191	200 A	282	242	-	M63 x 1.5
A210 315 MX6, 8	85	74.5	315	44	731	595	211	28	35	964	1111	200 A	282	242	-	M63 x 1.5
A210 315 MX10, 12	85	74.5	315	44	731	595	211	28	35	964	1111	200 A	282	242	-	M63 x 1.5
A210 315 MY2	69	69	315	44	809	628	230	28	35	1116	1260	400 B	415	340	265	M63 x 1.5
A210 315 MY4, 6, 8	85	74.5	315	44	809	628	230	28	35	1146	1290	400 B	415	340	265	M63 x 1.5
A210 315 L2	69	69	315	44	809	628	230	28	35	1236	1380	400 B	415	340	265	M63 x 1.5
A210 315 L4, 6, 8	85	74.5	315	44	809	628	230	28	35	1266	1410	400 B	415	340	265	M63 x 1.5
A210 315 LX2	69	69	315	44	809	628	230	28	35	1356	1500	400 B	415	340	265	M63 x 1.5
A210 315 LX4	85	74.5	315	44	809	628	230	28	35	1386	1530	400 B	415	340	265	M63 x 1.5
A210 315 LX6, 8	85	74.5	315	44	809	628	230	28	35	1266	1410	400 B	415	340	265	M63 x 1.5

⁽¹⁾ Terminal box left/right

Three-phase roller table motors with squirrel-cage rotor, transnorm light-duty version, for use on a frequency converter

Type of cooling IC 410, non-ventilated version
Size 355

Type of construction IM B3 [IM 1001]

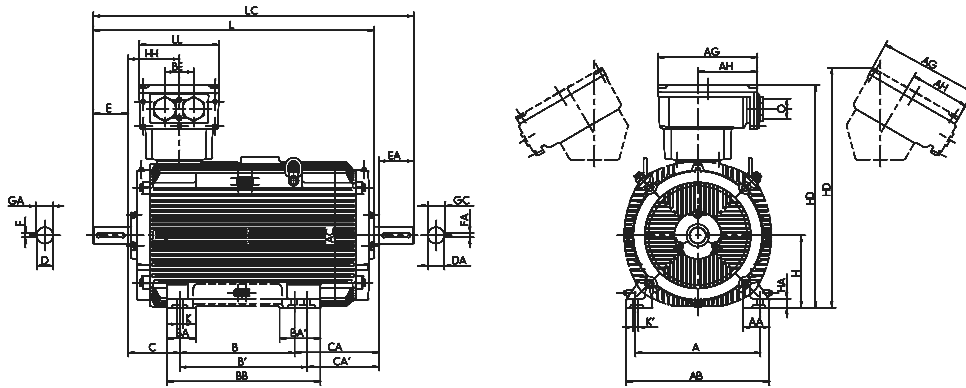

Type designation	Flange size	A	AA	AB	AC	B	BA	BA'	BB	C	CA	D	DA	DB ¹⁾	E	EA	F	FA
		b	n	f	g	a	m	m1	e	w1	w2	d	d1		l	l1	u	u1
A220 355 MY2, M2	FF 740	610	130	700	715	560	140	200	750	254	398	80	80	M20	170	170	22	22
A220 355 MY4, 6, 8	FF 740	610	130	700	715	560	140	200	750	254	398	100	80	M24	210	170	28	22
A220 355 M4	FF 740	610	130	700	715	560	140	200	750	254	398	100	80	M24	210	170	28	22
A220 355 M6, 8	FF 740	610	130	700	715	560	140	200	750	254	398	100	80	M24	210	170	28	22
A220 355 MX6, 8	FF 740	610	130	700	715	560	140	200	750	254	518	100	80	M24	210	170	28	22
A220 355 MX2	FF 740	610	130	700	715	560	140	200	750	254	518	80	80	M20	170	170	22	22
A220 355 LY2, L2	FF 740	610	130	700	715	630	140	200	750	254	448	80	80	M20	170	170	22	22
A220 355 MX4	FF 740	610	130	700	715	560	140	200	750	254	448	100	80	M24	210	170	28	22
A220 355 LY4, 6, 8, L4	FF 740	610	130	700	715	630	140	200	750	254	448	100	80	M24	210	170	28	22

¹⁾ Centre holes to DIN 332-DS

Three-phase roller table motors with squirrel-cage rotor, transnorm light-duty version, for use on a frequency converter

Type of cooling IC 410, non-ventilated version
Size 355

Type of construction IM B35 [IM 2001]

Flange dimensions, see page 9/23

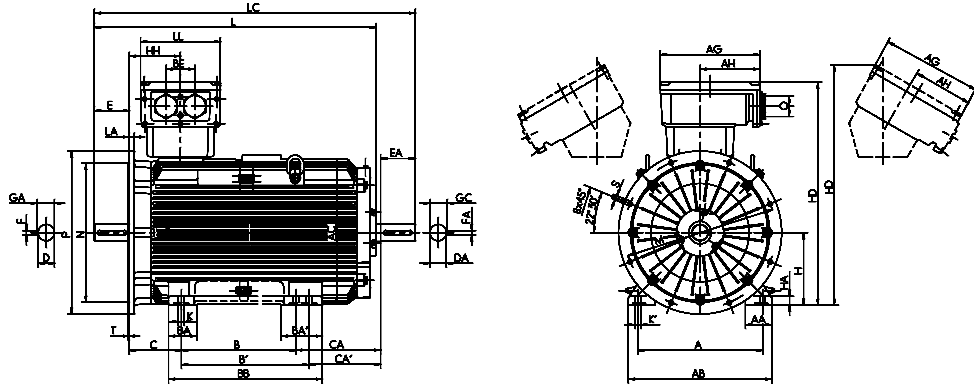

Type designation	GA	GC	H	HA	HD	HD**)	HH	K	K'	L	LC	TB Type	AG	LL	AH	BE	O
	t	t1	h	c	p	p	A	s	s'	k	k1				-		
A220 355 MY2, M2	85	85	355	44	1091	1172	250	28	35	1365	1552	630 A	496	390	301	140	M72 x 2
A220 355 MY4, 6, 8	106	85	355	44	1091	1172	250	28	35	1405	1592	630 A	496	390	301	140	M72 x 2
A220 355 M4	106	85	355	44	1091	1172	250	28	35	1405	1552	630 A	496	390	301	140	M72 x 2
A220 355 M6, 8	106	85	355	44	1091	1172	250	28	35	1405	1592	630 A	496	390	301	140	M72 x 2
A220 355 MX6, 8	106	85	355	44	1091	1172	250	28	35	1525	1712	630 A	496	390	301	140	M72 x 2
A220 355 MX2	85	85	355	44	1091	1172	250	28	35	1485	1672	630 A	496	390	301	140	M72 x 2
A220 355 LY2, L2	85	85	355	44	1091	1172	250	28	35	1485	1672	630 A	496	390	301	140	M72 x 2
A220 355 MX4	106	85	355	44	1091	1172	250	28	35	1525	1712	630 A	496	390	301	140	M72 x 2
A220 355 LY4, 6, 8, L4	106	85	355	44	1091	1172	250	28	35	1525	1712	630 A	496	390	301	140	M72 x 2

** Terminal box left/right

Three-phase roller table motors with squirrel-cage rotor, transnorm light-duty version, for use on a frequency converter

Type of cooling IC 410, non-ventilated version
 Sizes 56 to 280

Type of construction IM B14 [IM 3601]
 Flange dimensions, see page 9/23

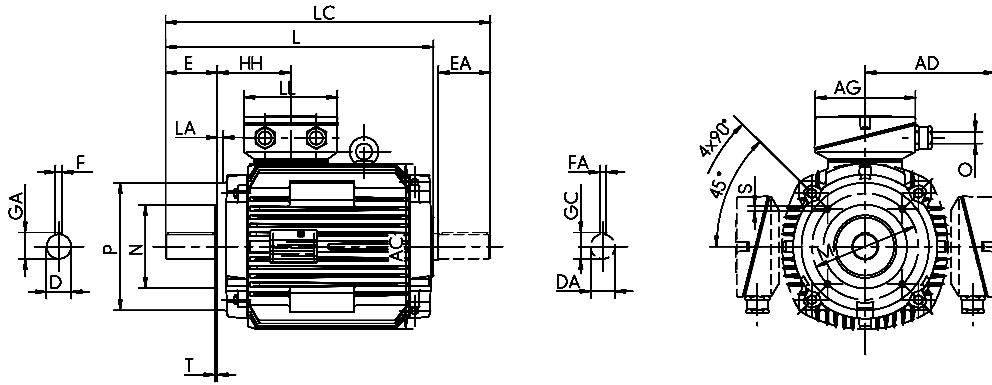

Type designation	Flange size		A	AA	AB	AC	AD	B	BA	BB	C	CA	D	DA	DB ¹⁾	E	EA	F	FA
	small	large	b	n	f	g	g1	a	m	e	w1	w2	d	d1		l	l1	u	u1
A210 63 K2, 4, 6 U	FT 75	FT 100	100	28	128	109	98	80	-	100	40	-	11	11	M4	23	23	4	4
A210 63 G2, 4, 6 U	FT 75	FT 100	100	28	128	109	98	80	-	100	40	-	11	11	M4	23	23	4	4
A210 71 K2, 4, 6, 8 U	FT 85	FT 115	112	32	138	124	104	90	-	116	45	-	14	14	M5	30	30	5	5
A210 71 G2, 4, 6, 8	FT 85	FT 115	112	32	138	124	104	90	-	116	45	-	14	14	M5	30	30	5	5
A210 80 K2, 4, 6, 8 U	FT 100	FT 130	125	38	168	139	111	100	-	125	50	-	19	19	M6	40	40	6	6
A210 80 G2, 4, 6, 8 U	FT 100	FT 130	125	38	168	139	111	100	-	125	50	-	19	19	M6	40	40	6	6
A210 90 S2, 4, 6, 8 U	FT 115	FT 130	140	40	178	157	119	100	-	130	56	-	24	22	M8	50	50	8	6
A210 90 L2, 4, 6, 8 U	FT 115	FT 130	140	40	178	157	119	125	-	155	56	-	24	22	M8	50	50	8	6
A210 100 L2, 4, 6, 8 U	FT 130	FT 165	160	45	192	177	126	140	-	175	63	-	28	24	M10	60	50	8	8
A210 100 LX4, 8 U	FT 130	FT 165	160	32	188	196	136	140	-	171	63	-	28	28	M10	60	60	8	8
A210 112 M2 U	FT 130	FT 165	190	50	224	196	136	140	-	180	70	-	28	28	M10	60	60	8	8
A210 112 M6, 8 U	FT 130	FT 165	190	50	224	196	136	140	-	180	70	-	28	28	M10	60	60	8	8
A210 112 MX2 U	FT 130	FT 165	190	50	224	196	136	140	-	180	70	-	28	28	M10	60	60	8	8
A210 112 M4 U	FT 130	FT 165	190	50	224	196	136	140	-	180	70	-	28	28	M10	60	60	8	8
A210 132 S2T U	FT 130	FT 165	216	50	256	196	155	140	-	180	89	-	38	28	M12	80	60	10	8
A210 132 S4T U	FT 130	FT 165	216	50	256	196	155	140	-	180	89	-	38	28	M12	80	60	10	8
A210 132 S2	FT 130	FT 165	216	50	256	217	178	140	55	180	89	97	38	32	M12	80	80	10	10
A210 132 SX2	FT 130	FT 165	216	50	256	217	178	140	55	180	89	117	38	32	M12	80	80	10	10
A210 132 S4, 6, 8	FT 130	FT 165	216	50	256	217	178	140	55	180	89	97	38	32	M12	80	80	10	10
A210 132 M4	FT 165	FT 215	216	50	256	258	199	178	55	218	89	79	38	38	M12	80	80	10	10
A210 132 MX6	FT 165	FT 215	216	50	256	258	199	178	55	218	89	79	38	38	M12	80	80	10	10
A210 132 M6, 8	FT 130	FT 165	216	50	256	217	178	178	55	218	89	79	38	32	M12	80	80	10	10
A210 160 M2	FT 165	FT 215	254	55	296	258	214	210	60	257	108	76	42	38	M16	110	80	12	10
A210 160 M4, 6, 8	FT 165	FT 215	254	55	296	258	214	210	60	257	108	76	42	38	M16	110	80	12	10
A210 160 MX8	FT 165	FT 215	254	55	296	258	199	210	60	257	108	76	42	38	M16	110	80	12	10
A210 160 MX2	FT 215	FT 265	254	55	296	313	242	210	60	257	108	87	42	42	M16	110	110	12	12
A210 160 L2, 4, 6, 8	FT 215	FT 265	254	55	296	313	242	254	60	301	108	81	42	42	M16	110	110	12	12
A210 180 M4	FT 265	-	279	62	328	313	242	241	65	288	121	81	48	42	M16	110	110	14	12
A210 180 L6, 8	FT 265	-	279	62	328	313	242	279	65	326	121	43	48	42	M16	110	110	14	12

¹⁾ Centre holes to DIN 332-DS

Three-phase roller table motors with squirrel-cage rotor, transnorm light-duty version, for use on a frequency converter

Type of cooling IC 410, non-ventilated version
 Sizes 56 to 280

Type of construction IM B34 [IM 2101]
 Flange dimensions, see page 9/23

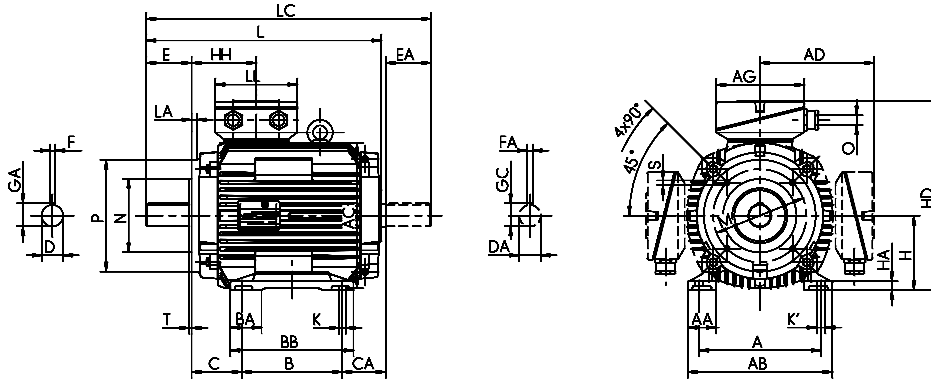

Type designation	GA	GC	H	HA	HD	HD**)	HH	K	K'	L	LC	TB Type	AG	LL	O
	t	tl	h	c	p	p	A	s	s'	k	k1				
A210 63 K2, 4, 6 U	12.5	12.5	63	10	161	***)	58	8	8	155	***)	KA 05	92	92	M20 x 1.5
A210 63 G2, 4, 6 U	12.5	12.5	63	10	161	***)	58	8	8	155	***)	KA 05	92	92	M20 x 1.5
A210 71 K2, 4, 6, 8 U	16	16	71	11	175	***)	61	8	8	177	***)	KA 05	92	92	M20 x 1.5
A210 71 G2, 4, 6, 8	16	16	71	11	175	***)	61	8	8	177	***)	KA 05	92	92	M20 x 1.5
A210 80 K2, 4, 6, 8 U	21.5	21.5	80	12	191	***)	67	10	10	217	***)	KA 05	92	92	M20 x 1.5
A210 80 G2, 4, 6, 8 U	21.5	21.5	80	12	191	***)	67	10	10	217	***)	KA 05	92	92	M20 x 1.5
A210 90 S2, 4, 6, 8 U	27	24.5	90	14	210	***)	70	10	10	241	***)	KA 05	92	92	M25 x 1.5
A210 90 L2, 4, 6, 8 U	27	24.5	90	14	210	***)	70	10	10	263	***)	KA 05	92	92	M25 x 1.5
A210 100 L2, 4, 6, 8 U	31	27	100	15	227	***)	75	12	12	289	***)	KA 05	92	92	M25 x 1.5
A210 100 LX4, 8 U	31	31	100	11	237	***)	77	12	12	314	***)	KA 05	92	92	M25 x 1.5
A210 112 M2 U	31	31	112	18	249	***)	77	12	12	314	***)	KA 05	92	92	M25 x 1.5
A210 112 M6, 8 U	31	31	112	18	249	***)	77	12	12	314	***)	KA 05	92	92	M25 x 1.5
A210 112 MX2 U	31	31	112	18	249	***)	77	12	12	348	***)	KA 05	92	92	M25 x 1.5
A210 112 M4 U	31	31	112	18	249	***)	77	12	12	348	***)	KA 05	92	92	M25 x 1.5
A210 132 S2T U	41	31	132	18	287	***)	105	12	12	387	***)	KA 05-13	104	112	M32 x 1.5
A210 132 S4T U	41	31	132	18	287	***)	105	12	12	417	***)	KA 05-13	104	112	M32 x 1.5
A210 132 S2	41	35	132	16	310	257	108	12	12	459	542	25 A	156	145	M32 x 1.5
A210 132 SX2	41	35	132	16	310	257	108	12	12	479	562	25 A	156	145	M32 x 1.5
A210 132 S4, 6, 8	41	35	132	16	310	257	108	12	12	459	542	25 A	156	145	M32 x 1.5
A210 132 M4	41	41	132	16	331	279	114	12	12	481	565	25 A	156	145	M32 x 1.5
A210 132 MX6	41	41	132	16	331	279	114	12	12	481	565	25 A	156	145	M32 x 1.5
A210 132 M6, 8	41	35	132	16	310	257	108	12	12	479	562	25 A	156	145	M32 x 1.5
A210 160 M2	45	41	160	18	374	307	114	15	15	559	643	63 A	193	167	M40 x 1.5
A210 160 M4, 6, 8	45	41	160	18	374	307	114	15	15	559	643	63 A	193	167	M40 x 1.5
A210 160 MX8	45	41	160	18	374	307	114	15	15	559	643	63 A	193	167	M40 x 1.5
A210 160 MX2	45	45	160	18	402	336	138	15	20	571	686	63 A	193	167	M40 x 1.5
A210 160 L2, 4, 6, 8	45	45	160	18	402	336	138	15	20	609	724	63 A	193	167	M40 x 1.5
A210 180 M4	51.5	45	180	20	422	369	138	15	20	609	724	63 A	193	167	M40 x 1.5
A210 180 L6, 8	51.5	45	180	20	422	369	138	15	20	609	724	63 A	193	167	M40 x 1.5

** Terminal box left/right
 *** upon request

Three-phase roller table motors with squirrel-cage rotor, transnorm light-duty version, for use on a frequency converter

Type of cooling IC 410, non-ventilated version
 Sizes 56 to 280

Type of construction IM B5 [IM 3001]

Type of construction IM V1 [IM 3011]

Flange dimensions, see page 9/23

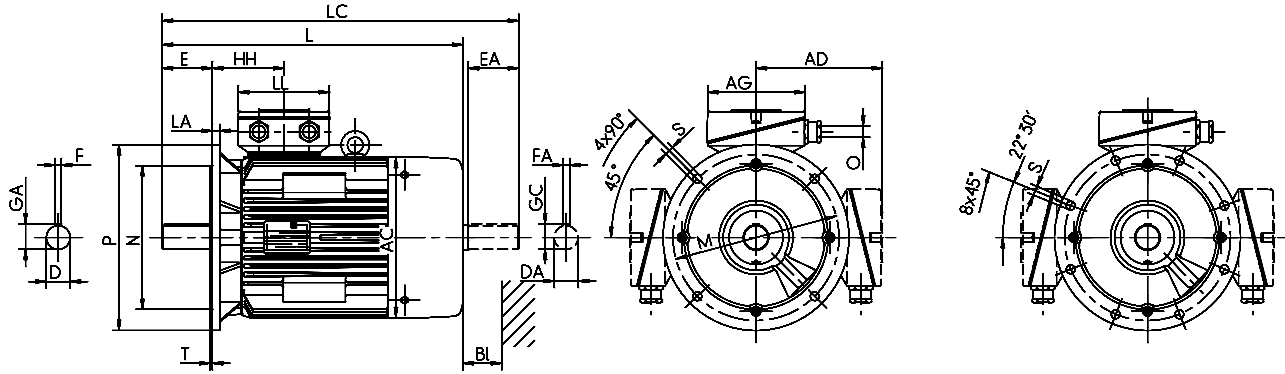

Type designation	Flange size	AC	AD	D	DA	DB ¹⁾	E	EA	F	FA	GA	GC	H	HH	L	LC	TB Type	AG	LL	O	Hole pattern
	g	g1	d	d1		l	l1	u	u1	t	t1	h	A	k	k1						
A210 63 K2, 4, 6 U	FF115	109	98	11	11	M4	23	23	4	4	12.5	12.5	63	58	155	***)	KA 05	92	92	M20 x 1.5	4L
A210 63 G2, 4, 6 U	FF115	109	98	11	11	M4	23	23	4	4	12.5	12.5	63	58	155	***)	KA 05	92	92	M20 x 1.5	4L
A210 71 K2, 4, 6, 8 U	FF130	124	104	14	14	M5	30	30	5	5	16	16	71	61	177	***)	KA 05	92	92	M20 x 1.5	4L
A210 71 G2, 4, 6, 8	FF130	124	104	14	14	M5	30	30	5	5	16	16	71	61	177	***)	KA 05	92	92	M20 x 1.5	4L
A210 80 K2, 4, 6, 8 U	FF 165	139	111	19	19	M6	40	40	6	6	21.5	21.5	80	67	217	***)	KA 05	92	92	M20 x 1.5	4L
A210 80 G2, 4, 6, 8 U	FF 165	139	111	19	19	M6	40	40	6	6	21.5	21.5	80	67	217	***)	KA 05	92	92	M20 x 1.5	4L
A210 90 S2, 4, 6, 8 U	FF 165	157	119	24	22	M8	50	50	8	6	27	24.5	90	70	241	***)	KA 05	92	92	M25 x 1.5	4L
A210 90 L2, 4, 6, 8 U	FF 165	157	119	24	22	M8	50	50	8	6	27	24.5	90	70	263	***)	KA 05	92	92	M25 x 1.5	4L
A210 100 L2, 4, 6, 8 U	FF 215	177	126	28	24	M10	60	50	8	8	31	27	100	75	289	***)	KA 05	92	92	M25 x 1.5	4L
A210 100 LX4, 8 U	FF 215	196	136	28	28	M10	60	60	8	8	31	31	100	77	314	***)	KA 05	92	92	M25 x 1.5	4L
A210 112 M2 U	FF 215	196	136	28	28	M10	60	60	8	8	31	31	112	77	314	***)	KA 05	92	92	M25 x 1.5	4L
A210 112 M6, 8 U	FF 215	196	136	28	28	M10	60	60	8	8	31	31	112	77	314	***)	KA 05	92	92	M25 x 1.5	4L
A210 112 MX2 U	FF 215	196	136	28	28	M10	60	60	8	8	31	31	112	77	348	***)	KA 05	92	92	M25 x 1.5	4L
A210 112 M4 U	FF 215	196	136	28	28	M10	60	60	8	8	31	31	112	77	348	***)	KA 05	92	92	M25 x 1.5	4L
A210 132 S2T U	FF265	196	155	38	28	M12	80	60	10	8	41	31	132	105	387	***)	KA 05-13	104	112	M32 x 1.5	4L
A210 132 S4T U	FF265	196	155	38	28	M12	80	60	10	8	41	31	132	105	417	***)	KA 05-13	104	112	M32 x 1.5	4L
A210 132 S2	FF265	217	178	38	32	M12	80	80	10	10	41	35	132	108	397	486	25 A	156	145	M32 x 1.5	4L
A210 132 SX2	FF265	217	178	38	32	M12	80	80	10	10	41	35	132	108	417	506	25 A	156	145	M32 x 1.5	4L
A210 132 S4, 6, 8	FF265	217	178	38	32	M12	80	80	10	10	41	35	132	108	397	486	25 A	156	145	M32 x 1.5	4L
A210 132 M4	FF265	258	199	38	38	M12	80	80	10	10	41	41	132	114	420	506	25 A	156	145	M32 x 1.5	4L
A210 132 MX6	FF265	258	199	38	38	M12	80	80	10	10	41	41	132	114	420	506	25 A	156	145	M32 x 1.5	4L
A210 132 M6, 8	FF265	217	178	38	32	M12	80	80	10	10	41	35	132	108	417	506	25 A	156	145	M32 x 1.5	4L
A210 160 M2	FF300	258	214	42	38	M16	110	80	12	10	45	41	160	114	498	584	63 A	193	167	M40 x 1.5	4L
A210 160 M4, 6, 8	FF300	258	214	42	38	M16	110	80	12	10	45	41	160	114	498	584	63 A	193	167	M40 x 1.5	4L
A210 160 MX8	FF300	258	199	42	38	M16	110	80	12	10	45	41	160	114	498	584	63 A	193	167	M40 x 1.5	4L
A210 160 MX2	FF300	313	242	42	42	M16	110	110	12	12	45	45	160	138	502	625	63 A	193	167	M40 x 1.5	4L
A210 160 L2, 4, 6, 8	FF300	313	242	42	42	M16	110	110	12	12	45	45	160	138	540	663	63 A	193	167	M40 x 1.5	4L
A210 180 M2	FF300	351	261	48	48	M16	110	110	14	14	51.5	51.5	180	147	562	689	63 A	193	167	M40 x 1.5	4L
A210 180 M4	FF300	313	242	48	42	M16	110	110	14	12	51.5	45	180	138	540	663	63 A	193	167	M40 x 1.5	4L
A210 180 L4	FF300	351	261	48	48	M16	110	110	14	14	51.5	51.5	180	147	607	734	63 A	193	167	M40 x 1.5	4L
A210 180 L6, 8	FF300	313	242	48	42	M16	110	110	14	12	51.5	45	180	138	540	663	63 A	193	167	M40 x 1.5	4L
A210 200 L2, 4, 6, 8	FF 350	351	261	55	48	M20	110	110	16	14	59	51.5	200	147	607	734	63 A	193	167	M40 x 1.5	4L
A210 200 LX6	FF 350	351	261	55	48	M20	110	110	16	14	59	51.5	200	147	607	734	63 A	193	167	M40 x 1.5	4L
A210 200 LX2	FF 350	390	300	55	55	M20	110	110	16	16	59	59	200	168	661	797	100 A	213	207	M50 x 1.5	4L
A210 225 S4, 8	FF 400	390	300	60	55	M20	140	110	18	16	64	59	225	168	691	827	100 A	213	207	M50 x 1.5	8L
A210 225 M2	FF 400	390	300	55	55	M20	110	110	16	16	59	59	225	168	701	837	100 A	213	207	M50 x 1.5	8L
A210 225 M4	FF 400	390	300	60	55	M20	140	110	18	16	64	59	225	168	731	867	100 A	213	207	M50 x 1.5	8L
A210 225 M6, 8	FF 400	390	300	60	55	M20	140	110	18	16	64	59	225	168	691	827	100 A	213	207	M50 x 1.5	8L
A210 250 M2	FF 500	440	358	60	55	M20	140	110	18	16	64	59	250	177	737	857	200 A	282	242	M63 x 1.5	8L
A210 250 M4, 6, 8	FF 500	440	358	65	55	M20	140	110	18	16	69	59	250	177	737	857	200 A	282	242	M63 x 1.5	8L
A210 280 S2	FF 500	490	386	65	65	M20	140	140	18	18	69	69	280	206	801	951	200 A	282	242	M63 x 1.5	8L
A210 280 S4, 6, 8	FF 500	490	386	75	65	M20	140	140	20	18	79.5	69	280	206	801	951	200 A	282	242	M63 x 1.5	8L
A210 280 M2	FF 500	490	386	65	65	M20	140	140	18	18	69	69	280	206	847	997	200 A	282	242	M63 x 1.5	8L
A210 280 M4, 6, 8	FF 500	490	386	75	65	M20	140	140	20	18	79.5	69	280	206	847	997	200 A	282	242	M63 x 1.5	8L

Low voltage electrical machines

¹⁾ Centre holes to DIN 332-DS
 ***) upon request

Three-phase roller table motors with squirrel-cage rotor, transnorm light-duty version, for use on a frequency converter

Type of cooling IC 410, non-ventilated version
Size 315

Type of construction IM B5 [IM 3001] to Size 315 MY

Type of construction IM V1 [IM 3011]

Flange dimensions, see page 9/23

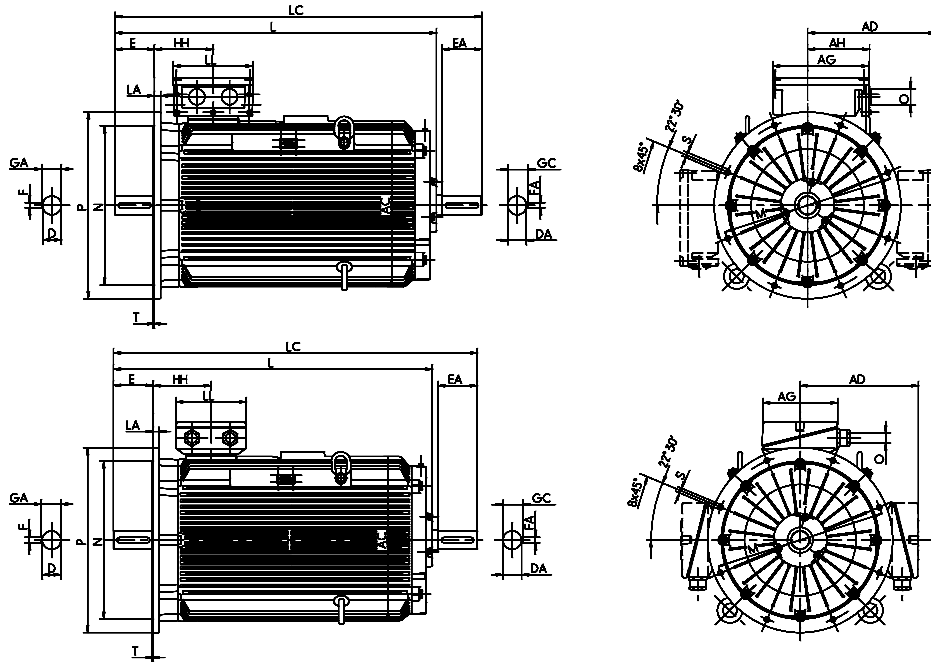

Type designation	Flange size	AC	AD	D	DA	DB ¹⁾	E	EA	F	FA	GA	GC	H	HH	L	LC	TB Type	AG	LL	AH	O
		g	g1	d	d1		l	l1	u	u1	t	t1	h	A	k	k1		x	z	-	r
A210 315 S2	FF 600	550	416	65	65	M20	140	140	18	18	69	69	315	211	879	1026	200 A	282	242	-	M63 x 1.5
A210 315 S4, 6, 8	FF 600	550	416	80	70	M20	170	140	22	20	85	74.5	315	211	909	1056	200 A	282	242	-	M63 x 1.5
A210 315 M2	FF 600	550	416	65	65	M20	140	140	18	18	69	69	315	211	934	1081	200 A	282	242	-	M63 x 1.5
A210 315 M4, 6, 8	FF 600	550	416	80	70	M20	170	140	22	20	85	74.5	315	211	964	1111	200 A	282	242	-	M63 x 1.5
A210 315 MX2	FF 600	550	416	65	65	M20	140	140	18	18	69	69	315	211	1014	1161	200 A	282	242	-	M63 x 1.5
A210 315 MX4	FF 600	550	416	80	70	M20	170	140	22	20	85	74.5	315	211	1044	1191	200 A	282	242	-	M63 x 1.5
A210 315 MX6, 8	FF 600	550	416	80	70	M20	170	140	22	20	85	74.5	315	211	964	1111	200 A	282	242	-	M63 x 1.5
A210 315 MX10, 12	FF 600	550	416	80	70	M20	170	140	22	20	85	74.5	315	211	964	1111	200 A	282	242	-	M63 x 1.5
A210 315 MY2	FF 600	610	494	65	65	M20	140	140	18	18	69	69	315	230	1116	1260	400 B	415	340	265	M63 x 1.5
A210 315 MY4, 6, 8	FF 600	610	494	80	70	M20	170	140	22	20	85	74.5	315	230	1146	1290	400 B	415	340	265	M63 x 1.5
A210 315 L2	FF 600	610	494	65	65	M20	140	140	18	18	69	69	315	230	1236	1380	400 B	415	340	265	M63 x 1.5
A210 315 L4, 6, 8	FF 600	610	494	80	70	M20	170	140	22	20	85	74.5	315	230	1266	1410	400 B	415	340	265	M63 x 1.5
A210 315 LX2	FF 600	610	494	65	65	M20	140	140	18	18	69	69	315	230	1356	1500	400 B	415	340	265	M63 x 1.5
A210 315 LX4	FF 600	610	494	80	70	M20	170	140	22	20	85	74.5	315	230	1386	1530	400 B	415	340	265	M63 x 1.5
A210 315 LX6, 8	FF 600	610	494	80	70	M20	170	140	22	20	85	74.5	315	230	1266	1410	400 B	415	340	265	M63 x 1.5

¹⁾ Centre holes to DIN 332-DS

Three-phase roller table motors with squirrel-cage rotor, transnorm light-duty version, for use on a frequency converter

Type of cooling IC 410, non-ventilated version
Size 355

Type of construction IM B5 [IM 3001]

Type of construction IM V1 [IM 3011]

Flange dimensions, see page 9/23

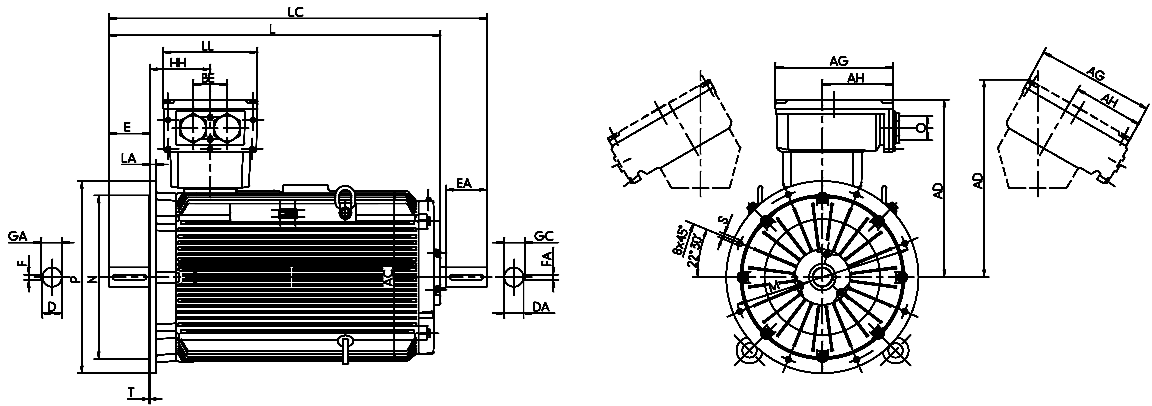

Type designation	Flange size	AC	AD	AD ^{*)}	D	DA	DB ^{*)}	E	EA	F	FA	GA	GC	H	HH	L	LC	TB	AG	LL	AH	BE	O	
		g	g1	g1	d	d1		l	l1	u	u1	t	t1	h	A	k	k1	Type		x	z	-	-	r
A220 355 MY2, M2	FF 740	715	736	817	80	80	M20	170	170	22	22	85	85	355	250	1365	1552	630 A	496	390	301	140	M72 x 2	
A220 355 MY4, 6, 8	FF 740	715	736	817	100	80	M24	210	170	28	22	106	85	355	250	1405	1592	630 A	496	390	301	140	M72 x 2	
A220 355 M4	FF 740	715	736	817	100	80	M24	210	170	28	22	106	85	355	250	1405	1592	630 A	496	390	301	140	M72 x 2	
A220 355 M6, 8	FF 740	715	736	817	100	80	M24	210	170	28	22	106	85	355	250	1405	1592	630 A	496	390	301	140	M72 x 2	
A220 355 MX6, 8	FF 740	715	736	819	100	80	M24	210	170	28	22	106	85	355	327	1525	1712	630 A	496	390	301	140	M72 x 2	
A220 355 MX2	FF 740	715	728	819	80	80	M20	170	170	22	22	85	85	355	327	1485	1712	1000 A	496	390	385	140	M72 x 2	
A220 355 LY2, L2	FF 740	715	728	819	80	80	M20	170	170	22	22	85	85	355	327	1485	1672	1000 A	496	390	385	140	M72 x 2	
A220 355 MX4	FF 740	715	728	819	100	80	M24	210	170	28	22	106	85	355	327	1525	1712	1000 A	496	390	385	140	M72 x 2	
A220 355 LY4, 6, 8, L4	FF 740	715	728	819	100	80	M24	210	170	28	22	106	85	355	327	1525	1712	1000 A	496	390	385	140	M72 x 2	

^{*)} Centre holes to DIN 332-DS
^{**)} Terminal box inclined left/right

Three-phase roller table motors with squirrel-cage rotor, transnorm light-duty version, for use on a frequency converter

Type of cooling IC 410, non-ventilated version
 Sizes 56 to 250

Type of construction IM B3 [IM 1001]

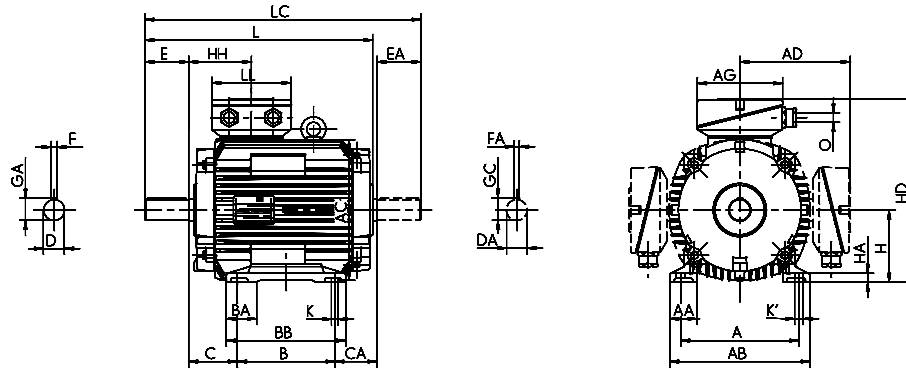

Type designation	Flange size	A	AA	AB	AC	AD	B	BA	BB	C	CA	D	DA	DB ¹⁾	E	EA	F	FA
		G	G1	G1	d	d1		L	L1	u	u1	t	t1	h	A	k	k1	
A200 56 K U	FF 115	90	18	110	109	98	71	-	86	36	-	11	11	M4	23	23	4	4
A200 56 GU	FF 115	90	18	110	109	98	71	-	86	36	-	11	11	M4	23	23	4	4
A200 63 K U	FF 130	100	21	120	124	104	80	-	95	40	-	14	14	M5	30	30	5	5
A200 63 GU	FF 130	100	21	120	124	104	80	-	95	40	-	14	14	M5	30	30	5	5
A200 71 K U	FF 165	112	23	135	139	111	90	-	114	45	-	19	19	M6	40	40	6	6
A200 71 GU	FF 165	112	23	135	139	111	90	-	114	45	-	19	19	M6	40	40	6	6
A200 80 K U	FF 165	125	26	152	157	119	100	-	124	50	-	22	22	M8	50	50	6	6
A200 80 GU	FF 165	125	26	152	157	119	100	-	124	50	-	22	22	M8	50	50	6	6
A200 90 L U	FF 215	140	25	167	177	126	125	-	150	56	-	24	24	M8	50	50	8	8
A200 100 S U	FF 215	160	32	188	196	136	112	-	171	63	-	28	28	M10	60	60	8	8
A200 100 L2, 4 U	FF 215	160	32	188	196	136	140	-	205	63	-	28	28	M10	60	60	8	8
A200 100 L6, 8 U	FF 215	160	32	188	196	136	140	-	171	63	-	28	28	M10	60	60	8	8
A200 100 LX4 U	FF 215	160	40	192	196	136	140	-	175	63	-	28	28	M10	60	60	8	8
A200 112 M2	FF 265	190	45	226	217	178	140	42	172	70	136	32	32	M12	80	80	10	10
A200 112 M4, 6, 8	FF 265	190	45	226	217	178	140	42	172	70	116	32	32	M12	80	80	10	10
A200 112 MX6, 8	FF 265	190	45	226	217	178	140	42	172	70	136	32	32	M12	80	80	10	10
A200 132 S	FF 300	216	50	256	258	199	140	47	180	89	117	38	38	M12	80	80	10	10
A200 132 M	FF 300	216	50	256	258	199	178	47	218	89	127	38	38	M12	80	80	10	10
A200 160 S2	FF 300	254	55	296	313	242	178	56	225	108	119	42	42	M16	110	110	12	12
A200 160 S4, 6, 8	FF 300	254	55	296	313	242	178	56	225	108	119	48	42	M16	110	110	14	12
A200 160 M2	FF 300	254	55	296	313	242	210	56	257	108	125	42	42	M16	110	110	12	12
A200 160 M4, 6, 8	FF 300	254	55	296	313	242	210	56	257	108	125	48	42	M16	110	110	14	12
A200 180 S2	FF 350	279	62	328	351	261	203	65	250	121	145	48	48	M16	110	110	14	14
A200 180 S4, 6, 8	FF 350	279	62	328	351	261	203	65	250	121	145	55	48	M20	110	110	16	14
A200 180 M2	FF 350	279	62	328	351	261	241	65	288	121	152	48	48	M16	110	110	14	14
A200 180 M4, 6, 8	FF 350 ¹⁾	279	62	328	351	261	241	65	288	121	152	55	48	M20	110	110	16	14
A200 200 M2	FF 400	318	70	372	390	300	267	70	322	133	177	55	55	M20	110	110	16	16
A200 200 M4, 6, 8	FF 400	318	70	372	390	300	267	70	322	133	177	60	55	M20	140	110	18	16
A200 200 L2	FF 400	318	70	372	390	300	305	70	360	133	179	55	55	M20	110	110	16	16
A200 200 L4, 6, 8	FF 400	318	70	372	390	300	305	70	360	133	179	60	55	M20	140	110	18	16
A200 225 M2	FF 500	356	75	413	440	324	311	75	368	149	147	55	55	M20	110	110	16	16
A200 225 M4, 6, 8	FF 500	356	75	413	440	324	311	75	368	149	147	65	55	M20	140	110	18	16
A200 250 S2	FF 500	406	84	469	490	386	311	84	374	168	192	65	65	M20	140	140	18	18
A200 250 S4, 6, 8	FF 500	406	84	469	490	386	311	84	374	168	192	75	65	M20	140	140	20	18
A200 250 M2	FF 500	406	84	469	490	386	349	84	412	168	154	65	65	M20	140	140	18	18
A200 250 M4	FF 500	406	84	469	490	386	349	84	412	168	200	75	65	M20	140	140	20	18
A200 250 M6, 8	FF 500	406	84	469	490	386	349	84	412	168	154	65	65	M20	140	140	18	18

¹⁾ Centre holes to DIN 332-DS

Three-phase roller table motors with squirrel-cage rotor, transnorm light-duty version, for use on a frequency converter

Type of cooling IC 410, non-ventilated version
 Sizes 56 to 250

Type of construction IM B35 [IM 1001]
 Flange dimensions, see page 9/23

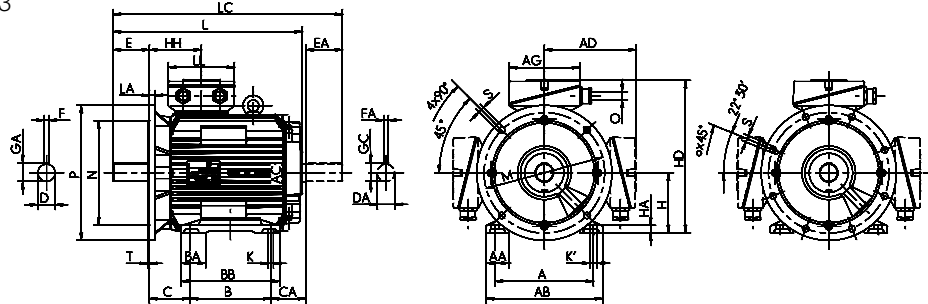

Size 112 to 160 with crowned flange

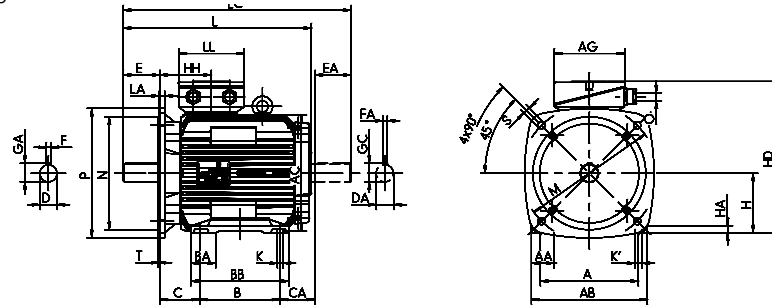

Type designation	GA	GC	H	HA	HD	HD ^{*)}	HH	K	K'	L	LC	TB Type	AG	LL	O	Hole pattern
	t	t1	h	c	p	p	A	s	s'	k	k1					
A200 56 K U	12.5	12.5	56	7	154	***)	58	6	6	155	***)	KA 05	92	92	M20 x 1.5	4L
A200 56 G U	12.5	12.5	56	7	154	***)	58	6	6	155	***)	KA 05	92	92	M20 x 1.5	4L
A200 63 K U	16	16	63	7.5	167	***)	61	7	7	177	***)	KA 05	92	92	M20 x 1.5	4L
A200 63 G U	16	16	63	7.5	167	***)	61	7	7	177	***)	KA 05	92	92	M20 x 1.5	4L
A200 71 K U	21.5	21.5	71	8	182	***)	67	7	7	217	***)	KA 05	92	92	M20 x 1.5	4L
A200 71 G U	21.5	21.5	71	8	182	***)	67	7	7	217	***)	KA 05	92	92	M20 x 1.5	4L
A200 80 K U	24.5	24.5	80	9	200	***)	70	10	10	241	***)	KA 05	92	92	M25 x 1.5	4L
A200 80 G U	24.5	24.5	80	9	200	***)	70	10	10	263	***)	KA 05	92	92	M25 x 1.5	4L
A200 90 L U	27	27	90	9.5	217	***)	75	10	10	279	***)	KA 05	92	92	M25 x 1.5	4L
A200 100 S U	31	31	100	11	237	***)	77	12	12	314	***)	KA 05	92	92	M25 x 1.5	4L
A200 100 L2, 4 U	31	31	100	11	237	***)	77	12	12	348	***)	KA 05	92	92	M25 x 1.5	4L
A200 100 L6, 8 U	31	31	100	11	237	***)	77	12	12	314	***)	KA 05	92	92	M25 x 1.5	4L
A200 100 LX4 U	31	31	100	15	237	***)	77	12	12	378	***)	KA 05	92	92	M25 x 1.5	4L
A200 112 M2	35	35	112	15	290	237	108	12	12	417	506	25 A	156	145	M32 x 1.5	4L
A200 112 M4, 6, 8	35	35	112	15	290	237	108	12	12	397	486	25 A	156	145	M32 x 1.5	4L
A200 112 MX6, 8	35	35	112	15	290	237	108	12	12	417	506	25 A	156	145	M32 x 1.5	4L
A200 132 S	41	41	132	15	331	279	114	12	12	420	506	25 A	156	145	M32 x 1.5	4L
A200 132 M	41	41	132	15	331	279	114	12	12	468	554	25 A	156	145	M32 x 1.5	4L
A200 160 S2	45	45	160	18	402	336	138	15	20	502	625	63 A	193	167	M40 x 1.5	4L
A200 160 S4, 6, 8	51.5	45	160	18	402	336	138	15	20	502	625	63 A	193	167	M40 x 1.5	4L
A200 160 M2	45	45	160	18	402	336	138	15	20	540	663	63 A	193	167	M40 x 1.5	4L
A200 160 M4, 6, 8	51.5	45	160	18	402	336	138	15	20	540	663	63 A	193	167	M40 x 1.5	4L
A200 180 S2	51.5	51.5	180	20	441	369	147	15	20	562	689	63 A	193	167	M40 x 1.5	4L
A200 180 S4, 6, 8	59	51.5	180	20	441	369	147	15	20	562	689	63 A	193	167	M40 x 1.5	4L
A200 180 M2	51.5	51.5	180	20	441	369	147	15	20	607	734	63 A	193	167	M40 x 1.5	4L
A200 180 M4, 6, 8	59	51.5	180	20	441	369	147	15	20	607	734	63 A	193	167	M40 x 1.5	4L
A200 200 M2	59	59	200	22	500	417	168	19	25	661	797	100 A	213	207	M50 x 1.5	4L
A200 200 M4, 6, 8	64	59	200	22	500	417	168	19	25	691	827	100 A	213	207	M50 x 1.5	4L
A200 200 L2	59	59	200	22	500	417	168	19	25	701	837	100 A	213	207	M50 x 1.5	4L
A200 200 L4, 6, 8	64	59	200	22	500	417	168	19	25	731	867	100 A	213	207	M50 x 1.5	4L
A200 225 M2	59	59	225	25	549	459	177	19	25	707	827	100 A	213	207	M50 x 1.5	8L
A200 225 M4, 6, 8	69	59	225	25	549	459	177	19	25	737	857	100 A	213	207	M50 x 1.5	8L
A200 250 S2	69	69	250	28	636	516	206	24	30	801	951	200 A	213	207	M50 x 1.5	8L
A200 250 S4, 6, 8	79.5	69	250	28	636	516	206	24	30	801	951	200 A	213	207	M50 x 1.5	8L
A200 250 M2	69	69	250	28	636	516	206	24	30	801	951	200 A	213	207	M50 x 1.5	8L
A200 250 M4	79.5	69	250	28	636	516	206	24	30	847	997	200 A	213	207	M50 x 1.5	8L
A200 250 M6, 8	69	69	250	28	636	516	206	24	30	801	951	200 A	213	207	M50 x 1.5	8L

*) Terminal box left/right
 **) upon request

Three-phase roller table motors with squirrel-cage rotor, transnorm light-duty version, for use on a frequency converter

Type of cooling IC 410, non-ventilated version
 Sizes 280 to 315

Type of construction IM B3 [IM 1001]

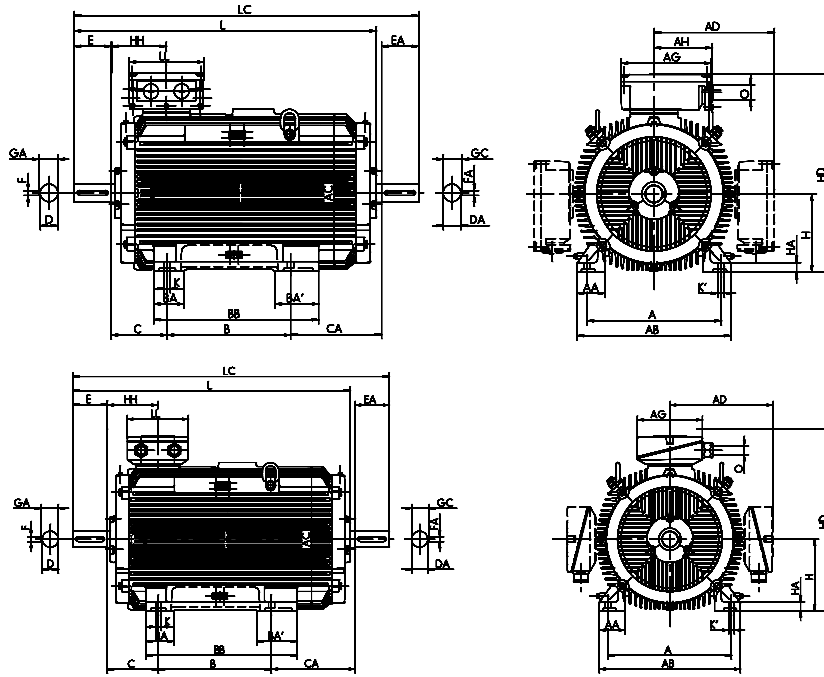

Type designation	Flange size	A	AA	AB	AC	AD	B	BA	BA'	BB	C	CA	D	DA	DB ¹⁾	E	EA	F	FA
		b	n	f	g	g1	a	m	m1	e	w1	w2	d	d1		l	l1	u	u1
A200 280 S2	FF 600	457	88	522	550	416	368	94		431	190	188	70	70	M20	140	140	20	20
A200 280 S4, 6, 8	FF 600	457	88	522	550	416	368	94		431	190	188	80	70	M20	170	140	22	20
A200 280 M2	FF 600	457	88	522	550	416	419	94		482	190	192	70	70	M20	140	140	20	20
A200 280 M4, 6, 8	FF 600	457	88	522	550	416	419	94		482	190	192	80	70	M20	170	140	22	20
A200 315 S2	FF 600	508	132	590	550	416	406	120		554	216	259	75	70	M20	140	140	20	20
A200 315 S4	FF 600	508	132	590	550	416	406			554	216	259	90	70	M24	170	140	25	20
A200 315 S6, 8	FF 600	508	132	590	550	416	406			554	216	179	90	70	M24	170	140	25	20
A200 315 M2	FF 600	508	110	590	610	494	457	120		587	216	307	75	75	M20	140	140	20	20
A200 315 M4, 6, 8	FF 600	508	110	590	610	494	457			587	216	307	90	75	M24	170	140	25	20
A200 315 M10, 12	FF 600	508	132	590	550	494	457			554	216	307	90	75	M24	170	140	25	20
A200 315 L2	FF 600	508	110	590	610	494	508	120		624	216	376	75	75	M20	140	140	20	20
A200 315 L4, 6, 8	FF 600	508	110	590	610	494	508			624	216	376	90	75	M24	170	140	25	20
A200 315 LX2	FF 600	508	110	590	610	494	508	120		624	216	496	75	75	M20	140	140	20	20
A200 315 LX4	FF 600	508	110	590	610	494	508			624	216	496	90	75	M24	170	140	25	20
A200 315 LX6, 8	FF 600	508	110	590	610	494	508			624	216	376	90	75	M24	170	140	25	20

¹⁾ Centre holes to DIN 332-DS

Three-phase roller table motors with squirrel-cage rotor, transnorm light-duty version, for use on a frequency converter

Type of cooling IC 410, non-ventilated version
 Sizes 280 to 315

Type of construction IM B35 [IM 1001]

Flange dimensions,
 see page 9/23

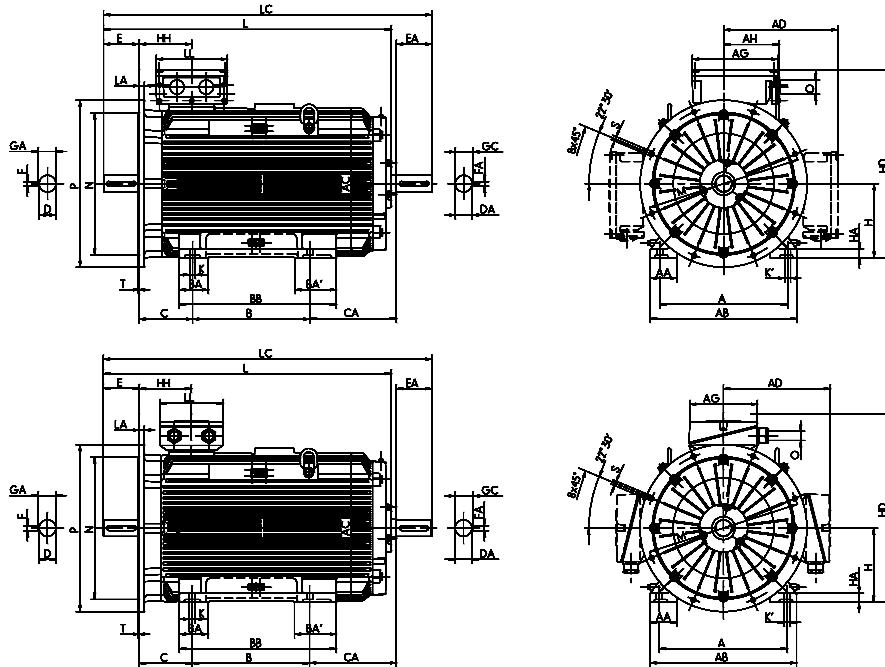

Type designation	GA	GC	H	HA	HD	HD ^{**}	HH	K	K'	L	LC	TB Type	AG	LL	AH	O
	t	t1	h	c	p	p	A	s	s'	k	k1	x	z	-	r	
A200 280 S2	74.5	74.5	280	40	696	560	211	24	30	879	1026	200 A	282	242	-	M63 x 1.5
A200 280 S4, 6, 8	85	74.5	280	40	696	560	211	24	30	909	1056	200 A	282	242	-	M63 x 1.5
A200 280 M2	74.5	74.5	280	40	696	560	211	24	30	934	1081	200 A	282	242	-	M63 x 1.5
A200 280 M4, 6, 8	85	74.5	280	40	696	560	211	24	30	964	1111	200 A	282	242	-	M63 x 1.5
A200 315 S2	79.5	74.5	315	44	731	595	211	28	35	1014	1161	200 A	282	242	-	M63 x 1.5
A200 315 S4	95	74.5	315	44	731	595	211	28	35	1044	1191	200 A	282	242	-	M63 x 1.5
A200 315 S6, 8	95	74.5	315	44	731	595	211	28	35	964	1111	200 A	282	242	-	M63 x 1.5
A200 315 M2	79.5	79.5	315	44	809	628	230	28	35	1116	1260	400 B	315	294	265	M63 x 1.5
A200 315 M4, 6, 8	95	79.5	315	44	809	628	230	28	35	1146	1290	400 B	315	294	265	M63 x 1.5
A200 315 M10, 12	95	79.5	315	44	809	628	211	28	35	1146	1290	400 B	315	294	265	M63 x 1.5
A200 315 L2	79.5	79.5	315	44	809	628	230	28	35	1236	1380	400 B	315	294	265	M63 x 1.5
A200 315 L4, 6, 8	95	79.5	315	44	809	628	230	28	35	1266	1410	400 B	315	294	265	M63 x 1.5
A200 315 LX2	79.5	79.5	315	44	809	628	230	28	35	1356	1500	400 B	315	294	265	M63 x 1.5
A200 315 LX4	95	79.5	315	44	809	628	230	28	35	1386	1530	400 B	315	294	265	M63 x 1.5
A200 315 LX6, 8	95	79.5	315	44	809	628	230	28	35	1266	1410	400 B	315	294	265	M63 x 1.5

** Terminal box left/right

Three-phase roller table motors with squirrel-cage rotor, transnorm light-duty version, for use on a frequency converter

Type of cooling IC 410, non-ventilated version
 Sizes 56 to 160

Type of construction IM B14 [IM 3601]
 Flange dimensions, see page 9/23

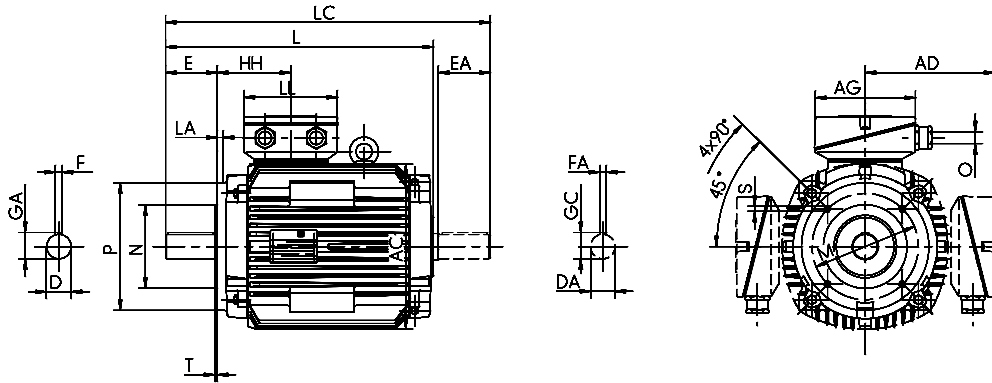

Type designation	Flange size		A	AA	AB	AC	AD	B	BA	BB	C	CA	D	DA	DB ¹⁾	E	EA	F	FA
	small	large	b	n	f	g	g1	a	m	e	w1	w2	d	d1		l	l1	u	u1
A200 56 K U	FT 65	FT 100	90	18	110	109	98	71	-	86	36	-	11	11	M4	23	23	4	4
A200 56 G U	FT 65	FT 100	90	18	110	109	98	71	-	86	36	-	11	11	M4	23	23	4	4
A200 63 K U	FT 75	FT 115	100	21	120	124	104	80	-	95	40	-	14	14	M5	30	30	5	5
A200 63 G U	FT 75	FT 115	100	21	120	124	104	80	-	95	40	-	14	14	M5	30	30	5	5
A200 71 K U	FT 85	FT 130	112	23	135	139	111	90	-	114	45	-	19	19	M6	40	40	6	6
A200 71 G U	FT 85	FT 130	112	23	135	139	111	90	-	114	45	-	19	19	M6	40	40	6	6
A200 80 K U	FT 100	FT 130	125	26	152	157	119	100	-	124	50	-	22	22	M8	50	50	6	6
A200 80 G U	FT 100	FT 130	125	26	152	157	119	100	-	146	50	-	22	22	M8	50	50	6	6
A200 90 L U	FT 115	FT 165	140	25	167	177	126	125	-	150	56	-	24	24	M8	50	50	8	8
A200 100 S U	FT 130	FT 165	160	32	188	196	136	112	-	171	63	-	28	28	M10	60	60	8	8
A200 100 L2, 4 U	FT 130	FT 165	160	32	188	196	136	140	-	205	63	-	28	28	M10	60	60	8	8
A200 100 L6, 8 U	FT 130	FT 165	160	32	188	196	136	140	-	171	63	-	28	28	M10	60	60	8	8
A200 100 LX4 U	FT 130	FT 165	160	40	192	196	136	140	-	175	63	-	28	28	M10	60	60	8	8
A200 112 M2	FT 130	FT 165	190	45	226	217	178	140	42	172	70	136	32	32	M12	80	80	10	10
A200 112 M4, 6, 8	FT 130	FT 165	190	45	226	217	178	140	42	172	70	116	32	32	M12	80	80	10	10
A200 112 MX6, 8	FT 130	FT 165	190	45	226	217	178	140	42	172	70	136	32	32	M12	80	80	10	10
A200 132 S	FT 165	FT 215	216	50	256	258	199	140	47	180	89	117	38	38	M12	80	80	10	10
A200 132 M	FT 165	FT 215	216	50	256	258	199	178	47	218	89	127	38	38	M12	80	80	10	10
A200 160 S2	FT 215	FT 265	254	55	296	313	242	178	56	225	108	119	42	42	M16	110	110	12	12
A200 160 S4, 6, 8	FT 215	FT 265	254	55	296	313	242	178	56	225	108	119	48	42	M16	110	110	14	12
A200 160 M2	FT 215	FT 265	254	55	296	313	242	210	56	257	108	125	42	42	M16	110	110	12	12
A200 160 M4, 6, 8	FT 215	FT 265	254	55	296	313	242	210	56	257	108	125	48	42	M16	110	110	14	12

¹⁾ Centre holes to DIN 332-DS

Three-phase roller table motors with squirrel-cage rotor, transnorm light-duty version, for use on a frequency converter

Type of cooling IC 410, non-ventilated version
 Sizes 56 to 160

Type of construction IM B34 [IM 2101]

Flange dimensions, see page 9/23

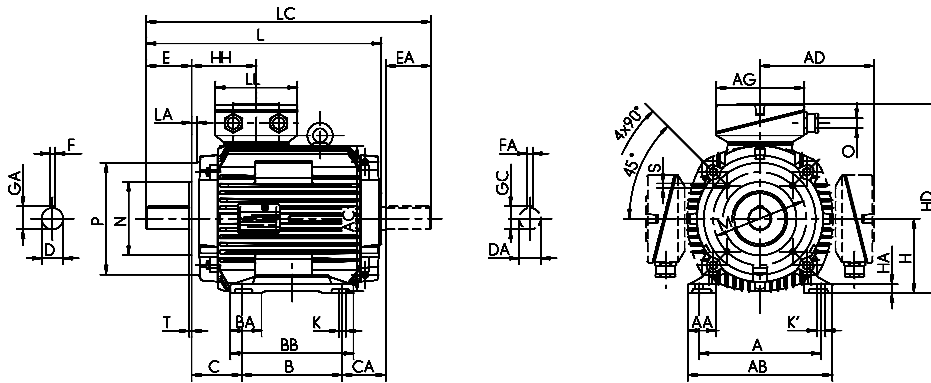

Type designation	GA	GC	H	HA	HD	HD**)	HH	K	K'	L	LC	TB Type	AG	LL	Ø
	t	t1	h	c	p	p	A	s	s'	k	k1				
A200 56 K U	12.5	12.5	56	7	154	***)	58	6	6	155	***)	KA 05	92	92	M20 x 1.5
A200 56 G U	12.5	12.5	56	7	154	***)	58	6	6	155	***)	KA 05	92	92	M20 x 1.5
A200 63 K U	16	16	63	7.5	167	***)	61	7	7	177	***)	KA 05	92	92	M20 x 1.5
A200 63 G U	16	16	63	7.5	167	***)	61	7	7	177	***)	KA 05	92	92	M20 x 1.5
A200 71 K U	21.5	21.5	71	8	182	***)	67	7	7	217	***)	KA 05	92	92	M20 x 1.5
A200 71 G U	21.5	21.5	71	8	182	***)	67	7	7	217	***)	KA 05	92	92	M20 x 1.5
A200 80 K U	24.5	24.5	80	9	200	***)	70	10	10	241	***)	KA 05	92	92	M25 x 1.5
A200 80 G U	24.5	24.5	80	9	200	***)	70	10	10	263	***)	KA 05	92	92	M25 x 1.5
A200 90 L U	27	27	90	9.5	217	***)	75	10	10	279	***)	KA 05	92	92	M25 x 1.5
A200 100 S U	31	31	100	11	237	***)	77	12	12	314	***)	KA 05	92	92	M25 x 1.5
A200 100 L2, 4 U	31	31	100	11	237	***)	77	12	12	348	***)	KA 05	92	92	M25 x 1.5
A200 100 L6, 8 U	31	31	100	11	237	***)	77	12	12	314	***)	KA 05	92	92	M25 x 1.5
A200 100 LX4 U	31	31	100	15	237	***)	77	12	12	378	***)	KA 05	92	92	M25 x 1.5
A200 112 M2	35	35	112	15	290	237	108	12	12	417	506	25 A	156	145	M32 x 1.5
A200 112 M4, 6, 8	35	35	112	15	290	237	108	12	12	397	486	25 A	156	145	M32 x 1.5
A200 112 MX6, 8	35	35	112	15	290	237	108	12	12	417	506	25 A	156	145	M32 x 1.5
A200 132 S	41	41	132	15	331	279	114	12	12	420	506	25 A	156	145	M32 x 1.5
A200 132 M	41	41	132	15	331	279	114	12	12	468	554	25 A	156	145	M32 x 1.5
A200 160 S2	45	45	160	18	402	336	138	15	20	502	625	63 A	193	167	M40 x 1.5
A200 160 S4, 6, 8	51.5	45	160	18	402	336	138	15	20	502	625	63 A	193	167	M40 x 1.5
A200 160 M2	45	45	160	18	402	336	138	15	20	540	663	63 A	193	167	M40 x 1.5
A200 160 M4, 6, 8	51.5	45	160	18	402	336	138	15	20	540	663	63 A	193	167	M40 x 1.5

** Terminal box left/right

*** upon request

Three-phase roller table motors with squirrel-cage rotor, transnorm light-duty version, for use on a frequency converter

Type of cooling IC 410, non-ventilated version
Size 56 to 250

Type of construction IM B5 [IM 3001]

Type of construction IM V1 [IM 3011]

Flange dimensions, see page 9/23

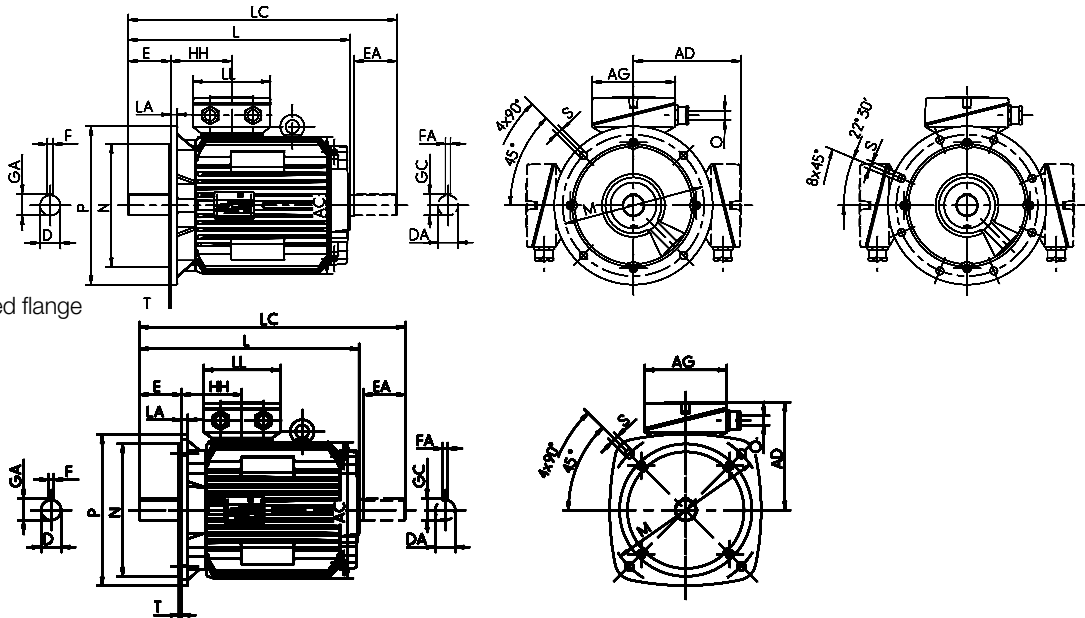

Size 160 with crowned flange

Type designation	Flange size	AC	AD	D	DA	DB ¹⁾	E	EA	F	FA	GA	GC	H	HH	L	LC	TB	Type	AG	LL	O	Hole pattern
		g	g1	d	d1		l	l1	u	u1	t	t1	h	A	k	k1						
A200 56 K U	FF 115	109	98	11	11	M4	23	23	4	4	12.5	12.5	56	58	155	***	KA 05	92	92	M20 x 1.5	4L	
A200 56 GU	FF 115	109	98	11	11	M4	23	23	4	4	12.5	12.5	56	58	155	***	KA 05	92	92	M20 x 1.5	4L	
A200 63 K U	FF 130	124	104	14	14	M5	30	30	5	5	16	16	63	61	177	***	KA 05	92	92	M20 x 1.5	4L	
A200 63 G U	FF 130	124	104	14	14	M5	30	30	5	5	16	16	63	61	177	***	KA 05	92	92	M20 x 1.5	4L	
A200 71 K U	FF 165	139	111	19	19	M6	40	40	6	6	21.5	21.5	71	67	217	***	KA 05	92	92	M20 x 1.5	4L	
A200 71 G U	FF 165	139	111	19	19	M6	40	40	6	6	21.5	21.5	71	67	217	***	KA 05	92	92	M20 x 1.5	4L	
A200 80 K U	FF 165	157	119	22	22	M8	50	50	6	6	24.5	24.5	80	70	241	***	KA 05	92	92	M25 x 1.5	4L	
A200 80 G U	FF 165	157	119	22	22	M8	50	50	6	6	24.5	24.5	80	70	263	***	KA 05	92	92	M25 x 1.5	4L	
A200 90 L U	FF 215	177	126	24	24	M8	50	50	8	8	27	27	90	75	279	***	KA 05	92	92	M25 x 1.5	4L	
A200 100 S U	FF 215	196	136	28	28	M10	60	60	8	8	31	31	100	77	314	***	KA 05	92	92	M25 x 1.5	4L	
A200 100 L2, 4 U	FF 215	196	136	28	28	M10	60	60	8	8	31	31	100	77	348	***	KA 05	92	92	M25 x 1.5	4L	
A200 100 L6, 8 U	FF 215	196	136	28	28	M10	60	60	8	8	31	31	100	77	314	***	KA 05	92	92	M25 x 1.5	4L	
A200 100 LX4 U	FF 215	196	136	28	28	M10	60	60	8	8	31	31	100	77	378	***	KA 05	92	92	M25 x 1.5	4L	
A200 112 M2	FF 265	217	178	32	32	M12	80	80	10	10	35	35	112	108	417	506	25 A	156	145	M32 x 1.5	4L	
A200 112 M4, 6, 8	FF 265	217	178	32	32	M12	80	80	10	10	35	35	112	108	397	486	25 A	156	145	M32 x 1.5	4L	
A200 112 MX6, 8	FF 265	217	178	32	32	M12	80	80	10	10	35	35	112	108	417	506	25 A	156	145	M32 x 1.5	4L	
A200 132 S	FF 300	258	199	38	38	M12	80	80	10	10	41	41	132	114	420	506	25 A	156	145	M32 x 1.5	4L	
A200 132 M	FF 300	258	199	38	38	M12	80	80	10	10	41	41	132	114	468	554	25 A	156	145	M32 x 1.5	4L	
A200 160 S2	FF 300	313	242	42	42	M16	110	110	12	12	45	45	160	138	502	625	63 A	193	167	M40 x 1.5	4L	
A200 160 S4, 6, 8	FF 300	313	242	48	42	M16	110	110	14	12	51.5	45	160	138	502	625	63 A	193	167	M40 x 1.5	4L	
A200 160 M2	FF 300	313	242	42	42	M16	110	110	12	12	45	45	160	138	540	663	63 A	193	167	M40 x 1.5	4L	
A200 160 M4, 6, 8	FF 300	313	242	48	42	M16	110	110	14	12	51.5	45	160	138	540	663	63 A	193	167	M40 x 1.5	4L	
A200 180 S2	FF 350	351	261	48	48	M16	110	110	14	14	51.5	51.5	180	147	562	689	63 A	193	167	M40 x 1.5	4L	
A200 180 S4, 6, 8	FF 350	351	261	55	48	M20	110	110	16	14	59	51.5	180	147	562	689	63 A	193	167	M40 x 1.5	4L	
A200 180 M2	FF 350	351	261	48	48	M16	110	110	14	14	51.5	51.5	180	147	607	734	63 A	193	167	M40 x 1.5	4L	
A200 180 M4, 6, 8	FF 350 ¹⁾	351	261	55	48	M20	110	110	16	14	59	51.5	180	147	607	734	63 A	193	167	M40 x 1.5	4L	
A200 200 M2	FF 400	390	300	55	55	M20	110	110	16	16	59	59	200	168	661	797	100 A	213	207	M50 x 1.5	4L	
A200 200 M4, 6, 8	FF 400	390	300	60	55	M20	140	110	18	16	64	59	200	168	691	827	100 A	213	207	M50 x 1.5	4L	
A200 200 L2	FF 400	390	300	55	55	M20	110	110	16	16	59	59	200	168	701	837	100 A	213	207	M50 x 1.5	4L	
A200 200 L4, 6, 8	FF 400	390	300	60	55	M20	140	110	18	16	64	59	200	168	731	867	100 A	213	207	M50 x 1.5	4L	
A200 225 M2	FF 500	440	324	55	55	M20	110	110	16	16	59	59	225	177	707	827	100 A	213	207	M50 x 1.5	8L	
A200 225 M4, 6, 8	FF 500	440	324	65	55	M20	140	110	18	16	69	59	225	177	737	857	100 A	213	207	M50 x 1.5	8L	
A200 250 S2	FF 500	490	386	65	65	M20	140	140	18	18	69	69	250	206	801	951	200 A	213	207	M50 x 1.5	8L	
A200 250 S4, 6, 8	FF 500	490	386	75	65	M20	140	140	20	18	79.5	69	250	206	801	951	200 A	213	207	M50 x 1.5	8L	
A200 250 M2	FF 500	490	386	65	65	M20	140	140	18	18	69	69	250	206	801	951	200 A	213	207	M50 x 1.5	8L	
A200 250 M4	FF 500	490	386	75	65	M20	140	140	20	18	79.5	69	250	206	847	997	200 A	213	207	M50 x 1.5	8L	
A200 250 M6, 8	FF 500	490	386	65	65	M20	140	140	18	18	69	69	250	206	801	951	200 A	213	207	M50 x 1.5	8L	

Low voltage electrical machines

Three-phase roller table motors with squirrel-cage rotor, transnorm light-duty version, for use on a frequency converter

Type of cooling IC 410, non-ventilated version
Size 280, 315

Type of construction IM B5 [IM 3001] to Size 315 M

Type of construction IM V1 [IM 3011]

Flange dimensions, see page 9/23

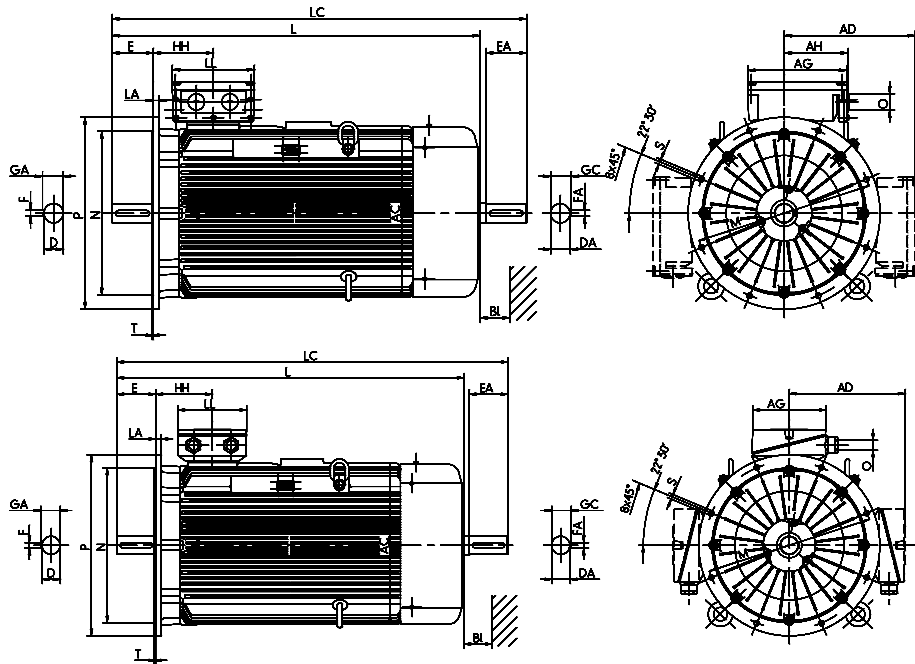

Type designation	Flange size	AC	AD	D	DA	DB ¹⁾	E	EA	F	FA	GA	GC	H	HH	L	LC	TB Type	AG	LL	AH	O
		g	g1	d	d1		l	l1	u	u1	t	t1	h	A	k	k1		x	z	-	r
A200 280 S2	FF 600	550	416	70	70	M20	140	140	20	20	74.5	74.5	280	211	879	1026	200 A	282	242	-	M63 x 1.5
A200 280 S4. 6. 8	FF 600	550	416	80	70	M20	170	140	22	20	85	74.5	280	211	909	1056	200 A	282	242	-	M63 x 1.5
A200 280 M2	FF 600	550	416	70	70	M20	140	140	20	20	74.5	74.5	280	211	934	1081	200 A	282	242	-	M63 x 1.5
A200 280 M4. 6. 8	FF 600	550	416	80	70	M20	170	140	22	20	85	74.5	280	211	964	1111	200 A	282	242	-	M63 x 1.5
A200 315 S2	FF 600	550	416	75	70	M20	140	140	20	20	79.5	74.5	315	211	1014	1161	200 A	282	242	-	M63 x 1.5
A200 315 S4	FF 600	550	416	90	70	M24	170	140	25	20	95	74.5	315	211	1044	1191	200 A	282	242	-	M63 x 1.5
A200 315 S6. 8	FF 600	550	416	90	70	M24	170	140	25	20	95	74.5	315	211	964	1111	200 A	282	242	-	M63 x 1.5
A200 315 M2	FF 600	610	494	75	75	M20	140	140	20	20	79.5	79.5	315	230	1116	1260	400 A	315	294	265	M63 x 1.5
A200 315 M4. 6. 8	FF 600	610	494	90	75	M24	170	140	25	20	95	79.5	315	230	1146	1290	400 B	315	294	265	M63 x 1.5
A200 315 M10. 12	FF 600	550	494	90	75	M24	170	140	25	20	95	79.5	315	211	1146	1290	400 B	315	294	265	M63 x 1.5
A200 315 L2	FF 600	610	494	75	75	M20	140	140	20	20	79.5	79.5	315	230	1236	1380	400 B	315	294	265	M63 x 1.5
A200 315 L4. 6. 8	FF 600	610	494	90	75	M24	170	140	25	20	95	79.5	315	230	1266	1410	400 B	315	294	265	M63 x 1.5
A200 315 LX2	FF 600	610	494	75	75	M20	140	140	20	20	79.5	79.5	315	230	1356	1500	400 B	315	294	265	M63 x 1.5
A200 315 LX4	FF 600	610	494	90	75	M24	170	140	25	20	95	79.5	315	230	1386	1530	400 B	315	294	265	M63 x 1.5
A200 315 LX6. 8	FF 600	610	494	90	75	M24	170	140	25	20	95	79.5	315	230	1266	1410	400 B	315	294	265	M63 x 1.5

¹⁾ Centre holes to DIN 332-DS

Overview of technical data

Three-phase roller table motors with squirrel-cage rotor, heavy-duty version for converter-fed operation, non-ventilated, Type of cooling IC 410

The most important technical data are summarised in the following table. Further information can be taken from the catalogue section "Introduction" (chapter 1).

Product group	Roller table motors, squirrel-cage rotor, IEC/EN
Series	ARC... version for converter-fed operation
Rated output	0.04 kW to 290 kW
Sizes	112 to 400
Housing material	Grey cast iron
Rated torque	8 Nm to 2560 Nm
Duty types	S7/S9 to IEC/EN 60034-1
Method of connection	Single-speed motors are designed in star-delta configuration as standard.
Stator winding insulation	Thermal class 155, optionally 155 [F(B)], 180 to IEC/EN 60034-1
Degree of protection	IP 55 to IEC/EN 60034-5, optionally IP 56 and higher
Type of cooling	IC 410 (non-ventilated) to IEC/EN 60034-6
Coolant temperature/ installation altitude	Standard -20 °C to +40 °C, Altitude 1000 m above sea level
Rated voltage	Standard voltages to EN 60038 50 Hz: 230 V, 400 V, 500 V, 690 V 60 Hz: 275 V, 460 V, 480 V, 600 V Rated Voltage ranges A to IEC/EN 60034-1
Types of construction	IM B3, IM B35, IM B5 and derived types to IEC/EN 60034-7
Paint finish	Normal finish "Moderate", colour RAL 7031, blue-grey Special finish "Worldwide", colour RAL 7031, blue-grey
Vibration severity grade	Grade "A" as standard for machines with no special vibration requirements
Shaft ends	to DIN 748 (IEC 60072), balanced with half-key
Sound pressure level	to DIN EN ISO 1680, tolerance + 3 dB, upon request
Limit speeds	Please refer to the section "Limit speeds".
Bearing design	Please refer to the section „Bearings“.
Motor mass	Please refer to the technical selection lists.
Terminal boxes	Please refer to the section "Terminal boxes".
Documentation	An operating and maintenance manual, a terminal plan and a safety data sheet are supplied with each motor.
Tolerances	Please refer to the section "Tolerances" in catalogue section "Introduction", Chapter 1.
Options	Please refer to the section "Overview of modifications" in catalogue section "Introduction", Chapter 1.

Motor selection data

Three-phase roller table motors with squirrel-cage rotor für use on a frequency converter, series ARC

Non-ventilated with surface cooling, IC 410

Planning data for switched operation calculations/motor preselection

Duty type S9, thermal class F, degree of protection IP 55, rated frequency 50 Hz

Insulation system for \hat{u} max. 1.35 kV; du/dt max. 1.5 kV/ μ s

ARC	Equivalent S1 output						Transient peak load (max. 10 s)					No load			
	P_{eff}	M_{eff}	I_B	n_B	η_B	$\cos\varphi_B$	M_{max}	M_{max}/M_{eff}	I_{max}	η_{max}	$\cos\varphi_{max}$	I_0	$\cos\varphi_0$	J	m
	(S1) kW	Nm	400 V A	rpm	referred to P_{eff} %	-	Nm		A	referred to M_{max} %	-	A	-	kgm ²	kg
Synchronous speed 1500 rpm – 4-pole version															
ARC 112 M4	2.3	15	4.7	1465	85.0	0.83	47	3.1	17	79.0	0.85	2.5	0.11	0.015	56
ARC 112 MX4	2.5	16	5.0	1465	85.0	0.85	49	3.0	18	77.0	0.87	2.5	0.10	0.017	63
ARC 112 MZ4	3.0	20	5.9	1460	86.0	0.85	60	3.0	19	75.0	0.88	2.8	0.11	0.020	67
ARC 132 S4	3.0	19	6.6	1480	85.0	0.77	61	3.2	20	84.0	0.81	3.8	0.13	0.028	82
ARC 132 M4	4.4	28	9.2	1475	87.5	0.79	93	3.3	30	82.0	0.89	5.3	0.10	0.035	95
ARC 132 MX4	6.2	40	12.5	1475	88.5	0.80	120	3.0	38	82.0	0.84	6.8	0.08	0.044	105
ARC 160 S4	5.5	35	11.5	1480	88.0	0.80	105	3.0	32	85.0	0.84	6.0	0.13	0.078	130
ARC 160 M4	7.7	50	16.0	1480	89.0	0.79	150	3.0	52	85.0	0.84	8.5	0.11	0.090	144
ARC 160 MX4	8.0	52	17.0	1480	89.5	0.77	160	3.1	52	85.0	0.84	9.5	0.11	0.104	160
ARC 160 L4	10.2	66	20.0	1480	88.5	0.83	200	3.0	68	86.0	0.85	10.0	0.13	0.116	170
ARC 180 S4	8.8	57	18.5	1480	86.0	0.80	175	3.1	55	84.5	0.83	12.0	0.07	0.138	170
ARC 180 M4	11.0	71	22.0	1485	90.5	0.80	215	3.0	72	90.0	0.85	15.0	0.07	0.168	215
ARC 180 L4	14.0	90	27.5	1480	90.5	0.81	270	3.0	80	88.0	0.85	17.0	0.09	0.203	250
ARC 200 M4	15.0	100	29.5	1475	91.0	0.80	307	3.1	94	91.1	0.85	15.0	0.08	0.275	270
ARC 200 L4	18.5	119	35.0	1485	92.5	0.82	367	3.1	115	91.5	0.82	16.0	0.09	0.313	335
ARC 200 LX4	20.0	128	39.5	1485	91.5	0.80	380	3.0	121	83.0	0.84	20.5	0.09	0.356	350
ARC 225 M4	22.0	141	43.0	1485	92.0	0.80	425	3.0	140	92.5	0.86	16.0	0.09	0.525	375
ARC 225 MX4	25.0	161	48.5	1485	91.0	0.82	480	3.0	145	89.0	0.82	20.0	0.09	0.638	420
ARC 250 S4	32.0	205	64.5	1490	93.0	0.77	624	3.0	181	92.5	0.86	31.5	0.07	0.950	520
ARC 250 M4	40.0	257	79.5	1485	93.0	0.78	778	3.0	245	93.7	0.86	33.5	0.08	1.100	580
ARC 280 S4	50.0	319	102.0	1495	93.5	0.76	968	3.0	330	95.0	0.85	40.0	0.08	1.960	830
ARC 280 M4	60.0	384	117.0	1492	94.0	0.79	1169	3.0	380	94.0	0.84	43.5	0.07	2.270	895
ARC 280 MX4	70.0	449	136.0	1490	94.0	0.79	1330	3.0	480	94.0	0.85	58.0	0.05	2.730	1015
ARC 315 M4	95.0	607	172.0	1495	96.0	0.83	1780	2.9	580	95.0	0.87	62.5	0.05	4.820	1300
ARC 315 L4	132.0	845	239.0	1492	96.0	0.83	2040	2.4	680	95.5	0.88	72.0	0.05	5.930	1450
ARC 315 LX4	150.0	961	268.0	1490	96.0	0.84	2884	3.0	980	95.5	0.88	98.0	0.04	6.820	1630
ARC 355 M4	160.0	1022	293.0	1495	95.0	0.83	3066	3.0	1050	95.0	0.79	127.0	0.05	10.000	2500
ARC 400 L4	240.0	1534		1494		upon request	6340	4.1						20.000	3210
ARC 400 LX4	290.0	1854		1494		upon request	7500	4.0						25.000	3460

Synchronous speed 1000 rpm – 6-pole version															
ARC	P_{eff}	M_{eff}	I_B	n_B	η_B	$\cos\varphi_B$	M_{max}	M_{max}/M_{eff}	I_{max}	η_{max}	$\cos\varphi_{max}$	I_0	$\cos\varphi_0$	J	m
	(S1) kW	Nm	A	rpm	referred to P_{eff} %	-	Nm		A	referred to M_{max} %	-	A	-	kgm ²	kg
ARC 112 M6	1.5	15	4.1	975	78.5	0.68	45	3.1	11	74.1	0.84	3.0	0.12	0.018	52
ARC 112 MX6	1.9	19	4.6	975	81.0	0.74	57	3.1	13	77.0	0.82	3.5	0.12	0.023	60
ARC 112 MZ6	2.2	22	5.6	970	81.0	0.70	66	3.1	15	74.0	0.84	4.2	0.10	0.029	62
ARC 132 S6	2.6	25	6.3	980	83.5	0.71	79	3.1	16	78.5	0.83	4.3	0.11	0.043	90
ARC 132 M6	3.5	34	9.3	980	82.5	0.66	103	3.0	24	83.6	0.77	6.5	0.11	0.053	95
ARC 132 MX6	4.2	41	10.5	978	84.0	0.70	130	3.2	28	82.8	0.80	7.0	0.11	0.066	110
ARC 160 S6	4.8	47	11.0	980	85.5	0.75	145	3.1	29	82.8	0.87	6.5	0.11	0.113	120
ARC 160 M6	6.5	63	14.0	985	86.0	0.79	195	3.1	40	84.0	0.84	7.7	0.13	0.145	145
ARC 160 L6	7.0	68	15.5	980	86.5	0.75	205	3.0	43	83.0	0.83	8.0	0.13	0.166	160
ARC 180 S6	7.6	74	15.0	985	89.5	0.81	228	3.1	46	85.6	0.87	7.9	0.15	0.228	190
ARC 180 M6	9.5	92	19.5	985	86.5	0.81	283	3.1	65	84.2	0.87	9.5	0.11	0.268	215
ARC 180 L6	11.0	107	23.0	985	86.0	0.80	320	3.0	70	84.0	0.85	12.0	0.12	0.324	250
ARC 200 M6	12.5	121	25.0	985	89.5	0.81	373	3.1	75	88.7	0.88	13.0	0.11	0.443	315
ARC 200 L6	15.0	145	30.0	985	89.5	0.80	450	3.1	90	88.5	0.88	14.0	0.11	0.514	330
ARC 200 LX6	19.5	189	37.5	985	90.0	0.83	580	3.1	115	88.7	0.88	20.0	0.11	0.620	360
ARC 225 M6	16.5	159	33.0	990	91.0	0.79	496	3.1	95	89.6	0.88	17.0	0.09	0.825	390
ARC 225 MX6	18.0	174		990			535	3.1						0.920	440
ARC 250 S6	22.0	212	43.0	991	91.0	0.81	540	2.5	110	90.7	0.88	24.0	0.08	1.280	465
ARC 250 M6	27.0	260	51.5	991	92.0	0.82	706	2.7	140	91.3	0.88	26.0	0.08	1.480	520
ARC 280 S6	37.0	356	71.5	992	93.5	0.83	1075	3.0	235	89.0	0.80	30.0	0.08	2.630	780
ARC 280 M6	44.0	423	84.0	993	93.5	0.81	1265	3.0	260	92.5	0.87	37.5	0.08	3.330	855
ARC 280 MX6	48.0	461	90.5	995	93.5	0.82	1608	3.5	320	92.5	0.86	45.0	0.07	3.600	890
ARC 315 M6	75.0	721	138.0	993	94.5	0.83	1945	2.7	380	93.9	0.87	55.0	0.06	6.000	1050
ARC 315 L6	90.0	866	164.0	993	94.5	0.84	2140	2.5	450	93.0	0.88	61.0	0.08	6.670	1250
ARC 315 LX6	100.0	962	183.0	993	95.0	0.83	2800	2.9	541	94.0	0.87	72.0	0.06	8.600	1460
ARC 355 M6	140.0	1344	263.0	995	96.0	0.80	4031	3.0	815	94.5	0.80	120.0	0.05	8.200	1650
ARC 355 MX6	160.0	1536	301.0	995	96.0	0.80	4607	3.0	885	96.5	0.80	147.0	0.04	12.800	2200
ARC 400 L6	210.0	2030		995		upon request	6400	3.2						25.000	3120
ARC 400 LX6	240.0	2310		995		upon request	7460	3.2						27.000	3340

Three-phase roller table motors with squirrel-cage rotor für use on a frequency converter, series ARC

Non-ventilated with surface cooling, IC 410
 Planning data for switched operation calculations/motor preselection
 Duty type S9, thermal class F, degree of protection IP 55, rated frequency 50 Hz
 Insulation system for \hat{u} max. 1.35 kV; du/dt max. 1.5 kV/ μ s

ARC	Equivalent S1 output						Transient peak load (max. 10 s)					No load			
	P_{eff} (S1) kW	M_{eff} Nm	I_B 400 V A	n_B rpm	η_B referred to P_{eff} %	$\cos\varphi_B$ -	M_{max} Nm	M_{max}/M_{eff}	I_{max} A	η_{max} referred to M_{max} %	$\cos\varphi_{max}$ -	I_0 A	$\cos\varphi_0$ -	J kgm ²	m kg
	Synchronous speed 750 rpm – 8-pole version														
ARC 112 M8	1.1	14	4.1	725	72.5	0.54	38	2.6	7	71.0	0.78	3.5	0.11	0.018	46
ARC 112 MX8	1.5	20	4.7	725	75.5	0.61	54	2.7	10	72.3	0.81	3.8	0.11	0.023	53
ARC 112 MZ8	1.7	22	5.4	725	75.5	0.60	65	3.0	12	66.0	0.80	4.3	0.11	0.029	62
ARC 132 S8	1.8	24	5.3	730	78.5	0.62	57	2.4	12	77.5	0.78	4.2	0.11	0.043	90
ARC 132 M8	2.5	33	9.0	734	76.0	0.53	87	2.7	15	74.0	0.77	6.0	0.10	0.053	95
ARC 132 MX8	3.0	39	9.4	730	77.0	0.60	110	2.8	20	72.0	0.78	7.0	0.10	0.066	110
ARC 160 S8	3.6	47	9.2	735	83.5	0.68	117	2.5	20	81.0	0.78	6.5	0.10	0.113	120
ARC 160 M8	5.0	65	12.5	730	83.0	0.69	174	2.7	29	82.0	0.79	9.0	0.11	0.145	145
ARC 160 L8	6.5	84	17.5	735	83.0	0.65	225	2.7	38	82.0	0.79	12.0	0.08	0.166	160
ARC 180 S8	6.5	84	16.5	740	87.0	0.66	257	3.1	41	84.0	0.81	12.0	0.08	0.228	180
ARC 180 M8	7.5	97	19.5	740	86.0	0.65	316	3.3	49	86.0	0.82	15.0	0.09	0.268	215
ARC 180 L8	8.0	103	20.0	740	87.0	0.67	325	3.2	55	82.0	0.80	14.0	0.08	0.324	250
ARC 200 M8	9.0	116	20.5	740	87.5	0.72	390	3.4	62	86.0	0.84	13.0	0.09	0.443	315
ARC 200 L8	11.0	143	22.5	735	89.5	0.78	410	2.9	63	87.0	0.84	13.0	0.08	0.514	330
ARC 225 M8	13.0	167	28.0	743	86.3	0.78	480	2.9	74	88.8	0.80	19.0	0.08	0.825	390
ARC 225 MX8	14.0	180					540	3.0						0.920	440
ARC 250 S8	17.5	226	38.0	740	90.5	0.73	590	2.6	90	89.8	0.81	22.0	0.07	1.350	510
ARC 250 M8	22.0	284	47.5	740	90.5	0.74	715	2.5	118	90.7	0.77	28.0	0.07	1.550	560
ARC 280 S8	28.0	359	62.0	745	92.0	0.71	1040	2.9	190	91.8	0.79	36.0	0.06	2.63	780
ARC 280 M8	35.0	449	76.5	745	93.0	0.71	1320	2.9	250	91.6	0.81	48.0	0.06	3.33	855
ARC 280 MX8	37.0	474	82.0	746	92.0	0.71	1685	3.6	290	92.3	0.80	72.0	0.05	3.60	890
ARC 315 M8	55.0	710	113.0	741	93.6	0.75	2100	3.0	306	91.1	0.82	68.0	0.05	6.000	1050
ARC 315 L8	68.0	875	146.0	745	94.4	0.71	2140	2.4	309	94.1	0.82	90.0	0.05	6.760	1250
ARC 315 LX8	85.0	1090	176.0	745	93.0	0.75	2724	2.5	385	92.0	0.82	88.0	0.06	8.710	1460
ARC 355 M8	90.0	1154	187.0	745	94.0	0.74	3461	3.0	520	93.5	0.80	95.0	0.05	9.500	1600
ARC 355 MX8	110.0	1410	228.0	745	94.0	0.74	4230	3.0	630	94.0	0.80	115.0	0.05	13.400	2200
ARC 400 L8	170.0	2176		746	upon request		6450							32.000	3120
ARC 400 LX8	200.0	2560		746	upon request		7750							39.000	3460

Synchronous speed 600 rpm – 10-pole version															
ARC	P_{eff}	M_{eff}	I_B	n_B	η_B	$\cos\varphi_B$	M_{max}	M_{max}/M_{eff}	I_{max}	η_{max}	$\cos\varphi_{max}$	I_0	$\cos\varphi_0$	J	m
ARC 112 M10	0.55	9		570	upon request		25	2.7						0.018	46
ARC 112 MX10	0.8	12	2.9	575	66.5	0.56	35	2.8	6	55.0	0.80			0.023	60
ARC 112 MZ10	0.85	14		570	upon request		40	2.8						0.029	62
ARC 132 S10	1.1	18		575	upon request		49	2.7						0.043	90
ARC 132 M10	1.5	25	5.2	575	78.0	0.53	60	2.4	10	80.0	0.65	4.5	0.09	0.053	95
ARC 132 MX10	1.8	30		575	upon request		75	2.5						0.066	110
ARC 160 S10	2.8	46		575	upon request		115	2.5						0.113	120
ARC 160 M10	3.0	50	8.7	575	80.0	0.62	120	2.4	18	80.0	0.75	6.5	0.11	0.145	145
ARC 160 L10	4.0	66		575	upon request		165	2.5						0.166	155
ARC 180 S10	4.5	73	15.5	590	82.0	0.50	225	3.0	33	82.0	0.75	12.5	0.07	0.228	180
ARC 180 M10	6.5	105	22.0	590	83.5	0.51	315	3.0	47	80.0	0.76			0.268	215
ARC 180 MX10	7.0	116	20.5	575	83.0	0.59	300	2.6	44	81.5	0.75	16.0	0.09	0.324	340
ARC 200 M10	8.5	140		580	upon request		380	2.7						0.443	315
ARC 200 L10	9.0	148		580	upon request		400	2.7						0.514	330
ARC 225 M10	11.0	178	33.0	590	86.5	0.56	480	2.7	84	85.5	0.73	23.5	0.07	0.825	390
ARC 225 MX10	12.0	198		580	upon request		535	2.7						0.920	440
ARC 250 S10	13.5	220		585	upon request		595	2.7						1.280	510
ARC 250 M10	17.0	278		585	upon request		750	2.7						1.480	560
ARC 280 S10	22.5	364		590	upon request		980	2.7						2.630	780
ARC 280 M10	27.5	445		590	upon request		1200	2.7						3.330	855
ARC 280 MX10	37.5	607		590	upon request		1640	2.7						3.600	935
ARC 315 M10	45.0	722	143.0	595	92.5	0.49	2190	3.0	295	93.0	0.70			6.000	1050
ARC 315 L10	55.0	890		590	upon request		2670	3.0						6.670	1250
ARC 315 LX10				590	upon request									6.670	1460
ARC 355 M10	68.0	1091		595	upon request		3274	3.0						9.500	1600
ARC 355 MX10	80.0	1284		595	upon request		3852	3.0						13.400	2200

Three-phase roller table motors with squirrel-cage rotor für use on a frequency converter, series ARC

Non-ventilated with surface cooling, IC 410

Planning data for switched operation calculations/motor preselection

Duty type S9, thermal class F, degree of protection IP 55, rated frequency 50 Hz

Insulation system for \hat{u} max. 1.35 kV; du/dt max. 1.5 kV/ μ s

ARC	Equivalent S1 output						Transient peak load (max. 10 s)					No load			
	P_{eff} (S1) kW	M_{eff} Nm	I_B 400 V A	n_B rpm	η_B referred to P_{eff} %	$\cos\varphi_B$ -	M_{max} Nm	M_{max}/M_{eff}	I_{max} A	η_{max} referred to M_{max} %	$\cos\varphi_{max}$ -	I_0 A	$\cos\varphi_0$ -	J kgm ²	m kg
Synchronous speed 500 rpm – 12-pole version															
ARC 112 M12	0.4	8		475	upon request	20	2.7							0.018	46
ARC 112 MX12	0.6	11		470	upon request	30	2.7							0.023	60
ARC 112 MZ12	0.7	14		470	upon request	40	2.8							0.029	62
ARC 132 S12	0.8	15		480	upon request	40	2.7							0.043	90
ARC 132 M12	1.1	22		480	upon request	60	2.7							0.053	95
ARC 132 MX12	1.3	26	7.5	485	66.0	0.38	67	2.6	12	74.0	0.60	8.0	0.11	0.053	110
ARC 160 S12	1.5	30		475	upon request	80	2.7							0.113	120
ARC 160 M12	2.75	54	13.5	488	71.0	0.42	160	3.0	24	79.5	0.64	12.6	0.10	0.145	145
ARC 160 L12	3.0	60		480	upon request	160	2.7							0.166	155
ARC 180 S12	3.0	60		480	upon request	160	2.7							0.228	180
ARC 180 M12	4.5	90	21.0	480	76.5	0.40	270	3.0	33			20.0	0.08	0.268	215
ARC 180 MX12	5.5	109	24.0	480	81.5	0.41	330	3.0	70			19.5	0.07	0.324	340
ARC 200 M12	6.5	129		480	upon request	350	2.7							0.443	315
ARC 200 L12	7.0	139		480	upon request	375	2.7							0.514	330
ARC 225 M12	8.5	169	35.0	480	81.0	0.43	510	3.0	67			32.5	0.07	0.825	390
ARC 225 MX12	9.0	179		480	upon request	480	2.7							0.920	440
ARC 250 S12	10.0	199		480	upon request	535	2.7							1.280	510
ARC 250 M12	12.0	232	49.0	495	84.5	0.42	625	2.7						1.480	560
ARC 280 S12	18.5	364		485	upon request	985	2.7							2.630	780
ARC 280 M12	22.5	443		485	upon request	1195	2.7							3.330	855
ARC 280 MX12	27.5	541		485	upon request	1460	2.7							3.600	935
ARC 315 M12	37.5	738		485	upon request	1995	2.7							6.000	1050
ARC 315 L12				485	upon request									6.670	1250
ARC 315 LX12	45	886		485	upon request	2390	2.7							6.670	1460
ARC 355 M12	55	1072		490	upon request	2895	2.7							9.500	1600
ARC 355 MX12	66	1286		490	upon request	3475	2.7							13.400	2200
ARC 400 L12	110.00	2110		497	upon request	6000	2.8							37.000	3000
ARC 400L X12	132.00	2550		497	upon request	7320	2.9							45.000	3320

Three-phase roller table motors with squirrel-cage rotor für use on a frequency converter, series ARC

Non-ventilated with surface cooling, IC 410
 Planning data for switched operation calculations/motor preselection
 Duty type S9, thermal class F, degree of protection IP 55, rated frequency 50 Hz
 Insulation system for \hat{u} max. 1.8 kV; du/dt max. 5 kV/ μ s

ARC	Equivalent S1 output						Transient peak load (max. 10 s)					No load			
	P_{eff} (S1) kW	M_{eff} Nm	I_B 500 V A	n_B rpm	η_B referred to P_{eff} %	$\cos\varphi_B$ -	M_{max} Nm	M_{max}/M_{eff}	I_{max} A	η_{max} referred to M_{max} %	$\cos\varphi_{max}$ -	I_0 A	$\cos\varphi_0$ -	J kgm ²	m kg
	Synchronous speed 1500 rpm – 4-pole version														
ARC 112 M4 TU	2.3	15	3.8	1460	83.5	0.84	43	2.9	10	78.0	0.86	2.0	0.12	0.015	56
ARC 112 MX4 TU	2.5	16	4.0	1465	84.0	0.85	46	2.8	15	77.0	0.87	2.1	0.11	0.017	63
ARC 112 MZ4 TU	2.8	18	4.5	1470	85.0	0.84	55	3.0	17	69.0	0.87	3.3	0.11	0.020	67
ARC 132 S4 TU	3.0	19	5.2	1475	85.0	0.78	61	3.1	16	84.0	0.81	2.9	0.12	0.028	82
ARC 132 M4 TU	4.4	28	7.4	1475	87.0	0.79	93	3.3	24	82.0	0.89	4.5	0.10	0.035	95
ARC 132 MX4 TU	5.5	36	9.1	1470	87.0	0.80	110	3.1	27	80.0	0.87	4.8	0.10	0.044	105
ARC 160 S4 TU	5.5	35	8.8	1480	88.0	0.82	105	3.0	28	82.0	0.85	5.0	0.13	0.078	130
ARC 160 M4 TU	7.7	50	12.5	1480	89.0	0.79	150	3.0	42	85.0	0.84	8.5	0.11	0.090	144
ARC 160 MX4 TU	8.0	52	13.5	1480	89.5	0.77	160	3.1	50	85.0	0.83	7.5	0.11	0.104	160
ARC 160 L4 TU	10.2	66	16.0	1480	88.5	0.83	200	3.0	55	86.0	0.85	8.0	0.13	0.116	170
ARC 180 S4 TU	8.8	57	15.0	1480	86.0	0.80	175	3.1	44	84.5	0.83	10.0	0.07	0.138	170
ARC 180 M4 TU	11.0	71	17.5	1485	90.5	0.80	215	3.0	58	90.0	0.85	12.5	0.07	0.168	215
ARC 180 L4 TU	14.0	90	22.0	1480	91.0	0.82	270	3.0	79	88.0	0.85	13.5	0.10	0.203	250
ARC 200 M4 TU	15.0	100	24.0	1475	91.0	0.80	307	3.1	76	91.1	0.85	12.5	0.08	0.275	270
ARC 200 L4 TU	18.5	119	28.0	1485	92.5	0.82	367	3.1	87	91.5	0.82	13.5	0.09	0.313	335
ARC 200 LX4 TU	20.0	128	31.5	1485	91.5	0.80	380	3.0	97	83.0	0.84	17.0	0.09	0.356	350
ARC 225 M4 TU	22.0	141	34.5	1485	92.0	0.80	425	3.0	112	92.5	0.86	13.5	0.09	0.525	375
ARC 225 MX4 TU	25.0	161	38.5	1485	91.0	0.82	480	3.0	116	89.0	0.82	16.5	0.09	0.638	420
ARC 250 S4 TU	32.0	205	51.5	1490	93.0	0.77	624	3.0	145	92.5	0.86	26.3	0.07	0.950	520
ARC 250 M4 TU	40.0	257	63.5	1485	93.0	0.78	778	3.0	196	93.7	0.86	28.0	0.08	1.100	580
ARC 280 S4 TU	50.0	319	81.0	1495	93.5	0.76	968	3.0	264	95.0	0.85	33.5	0.08	1.960	830
ARC 280 M4 TU	60.0	384	93.5	1492	94.0	0.79	1169	3.0	304	94.0	0.84	36.5	0.07	2.270	895
ARC 280 MX4 TU	70.0	449	109.0	1490	94.0	0.79	1330	3.0	384	94.0	0.85	48.5	0.05	2.730	1015
ARC 315 M4 TU	95.0	607	138.0	1495	96.0	0.83	1780	2.9	464	95.0	0.87	52.0	0.05	4.820	1300
ARC 315 L4 TU	132.0	845	191.0	1492	96.0	0.83	2040	2.4	544	95.5	0.88	60.0	0.05	5.930	1450
ARC 315 LX4 TU	150.0	961	215.0	1490	96.0	0.84	2884	3.0	784	95.5	0.88	82.0	0.04	6.820	1630
ARC 355 M4 TU	160.0	1022	234.0	1495	95.0	0.83	3066	3.0	850	95.0	0.79	106.0	0.05	10.000	2500
ARC 400 L4 TU	240.0	1534		1494	upon request		6340	4.1						20.000	3210
ARC 400 LX 4 TU	290.0	1854		1494	upon request		7500	4.0						25.000	3460
Synchronous speed 1000 rpm – 6-pole version															
ARC 112 M6 TU	1.5	15	3.3	975	77.0	0.69	52	2.9	9	74.1	0.84	2.4	0.12	0.018	52
ARC 112 MX6 TU	1.9	19	3.9	975	78.0	0.73	50	2.7	10	77.0	0.82	2.7	0.12	0.023	60
ARC 112 MZ6 TU	2.2	22	4.2	970	81.0	0.74	60	2.8	11	74.0	0.84	3.1	0.11	0.029	62
ARC 132 S6 TU	2.6	25	5.7	980	80.0	0.66	79	3.1	14	76.0	0.85	4.2	0.13	0.043	90
ARC 132 M6 TU	3.5	34	6.5	975	81.0	0.77	103	3.1	19	83.6	0.77	4.5	0.13	0.053	95
ARC 132 MX6 TU	4.2	41	8.0	975	83.0	0.73	130	3.0	23	82.8	0.80	5.0	0.11	0.066	110
ARC 160 S6 TU	4.8	47	8.6	980	85.5	0.75	145	3.1	25	82.8	0.87	5.5	0.11	0.113	120
ARC 160 M6 TU	6.5	63	11.0	980	86.0	0.78	195	3.1	32	84.0	0.84	6.5	0.12	0.145	145
ARC 160 L6 TU	7.0	68	12.5	980	85.5	0.75	205	3.0	35	83.0	0.81	6.7	0.13	0.166	160
ARC 180 S6 TU	7.6	73	12.5	980	85.5	0.82	200	2.7	32	84.0	0.88	6.5	0.15	0.228	180
ARC 180 M6 TU	9.5	92	16.0	985	86.5	0.80	283	3.1	48	84.2	0.87	8.0	0.12	0.268	215
ARC 180 L6 TU	11.0	107	18.5	985	86.0	0.80	320	3.0	56	84.0	0.85	10.0	0.12	0.324	250
ARC 200 M6 TU	12.5	121	20.0	985	89.5	0.81	373	3.1	60	88.7	0.88	11.0	0.11	0.443	315
ARC 200 L6 TU	15.0	145	24.0	985	89.5	0.80	450	3.1	72	88.5	0.88	12.0	0.11	0.514	330
ARC 200 LX6 TU	19.5	189	31.0	985	90.0	0.83	580	3.1	92	88.7	0.88	17.0	0.12	0.620	360
ARC 225 M6 TU	16.5	159	26.5	990	91.0	0.79	496	3.1	76	89.6	0.88	14.0	0.09	0.825	390
ARC 225 MX6 TU	18.0	174		990			535	3.1						0.920	440
ARC 250 S6 TU	22.0	212	34.5	991	91.0	0.81	540	2.5	88	90.7	0.88	20.0	0.08	1.280	465
ARC 250 M6 TU	27.0	260	41.5	991	92.0	0.82	706	2.7	112	91.3	0.88	22.0	0.08	1.480	520
ARC 280 S6 TU	37.0	356	71.5	992	93.5	0.83	1075	3.0	235	89.0	0.80	30.0	0.08	2.630	780
ARC 280 M6 TU	44.0	424	66.5	992	93.5	0.82	1265	3.0	208	92.5	0.87	34.0	0.07	3.330	855
ARC 280 MX6 TU	48.0	461	72.5	995	93.5	0.82	1608	3.5	256	92.5	0.86	37.5	0.07	3.600	890
ARC 315 M6 TU	75.0	721	110.0	993	94.5	0.83	1945	2.7	304	93.9	0.87	46.0	0.06	6.000	1050
ARC 315 L6 TU	90.0	866	131.0	993	94.5	0.84	2140	2.5	360	93.0	0.88	51.0	0.08	6.670	1250
ARC 315 LX6 TU	100.0	962	146.0	993	95.0	0.83	2800	2.9	433	94.0	0.87	60.0	0.06	8.600	1460
ARC 355 M6 TU	140.0	1344	210.0	995	96.0	0.80	4031	3.0	652	94.5	0.80	100.0	0.05	8.200	1650
ARC 355 MX6 TU	160.0	1536	241.0	995	96.0	0.80	4607	3.0	708	96.5	0.80	123.0	0.04	12.800	2200
ARC 400 L6 TU	210.0	2030		995	upon request		6400	3.2						25.000	3120
ARC 400 LX6 TU	240.0	2310		995	upon request		7460	3.2						27.000	3340

Three-phase roller table motors with squirrel-cage rotor für use on a frequency converter, series ARC

Non-ventilated with surface cooling, IC 410
 Planning data for switched operation calculations/motor preselection
 Duty type S9, thermal class F, degree of protection IP 55, rated frequency 50 Hz
 Insulation system for \hat{u} max. 1.8 kV; du/dt max. 5 kV/ μ s

ARC	Equivalent S1 output						Transient peak load (max. 10 s)					No load			
	P_{eff}	M_{eff}	I_B	n_B	η_B	$\cos\varphi_B$	M_{max}	M_{max}/M_{eff}	I_{max}	η_{max}	$\cos\varphi_{max}$	I_0	$\cos\varphi_0$	J	m
	(S1) kW	Nm	500 V A	rpm	referred to P_{eff} %	-	Nm	-	A	referred to M_{max} %	-	A	-	kgm ²	kg
Synchronous speed 750 rpm – 8-pole version															
ARC 112 M8 TU	0.9	12	2.7	725	70.5	0.55	32	2.7	8	70.0	0.79	2.3	0.13	0.018	46
ARC 112 MX8 TU	1.3	17	3.2	725	73.5	0.63	45	2.6	9	71.5	0.82	2.6	0.13	0.023	53
ARC 112 MZ8 TU	1.5	20	3.7	720	74.5	0.63	48	2.4	10	64.0	0.81	3.0	0.12	0.029	62
ARC 132 S8 TU	1.8	24	4.4	730	75.0	0.63	57	2.4	10	77.5	0.78	3.0	0.11	0.043	90
ARC 132 M8 TU	2.5	33	6.0	730	74.5	0.65	87	2.7	13	74.0	0.77	4.5	0.11	0.053	95
ARC 132 MX8 TU	3.0	39	7.7	730	75.0	0.60	110	2.8	16	72.0	0.78	6.0	0.11	0.066	110
ARC 160 S8 TU	3.6	47	7.6	735	83.0	0.66	117	2.5	25	81.0	0.78	6.5	0.10	0.113	120
ARC 160 M8 TU	5.0	65	10.5	735	83.5	0.65	174	2.7	23	79.0	0.80	7.5	0.10	0.145	145
ARC 160 L8 TU	6.5	85	13.5	730	83.0	0.66	225	2.6	31	78.0	0.79	9.0	0.09	0.166	160
ARC 180 S8 TU	6.5	84	13.0	740	87.0	0.66	257	3.1	33	84.0	0.81	10.0	0.08	0.228	190
ARC 180 M8 TU	7.5	97	15.5	740	86.0	0.65	316	3.3	39	86.0	0.82	12.5	0.09	0.268	215
ARC 180 L8 TU	8.0	103	16.0	740	87.0	0.67	325	3.2	44	82.0	0.80	11.5	0.08	0.324	250
ARC 200 M8 TU	9.0	116	16.5	740	87.5	0.72	390	3.4	50	86.0	0.84	11.0	0.09	0.443	315
ARC 200 L8 TU	11.0	143	18.0	735	89.5	0.78	410	2.9	51	87.0	0.84	11.0	0.08	0.514	330
ARC 225 M8 TU	13.0	167	22.5	743	86.3	0.78	480	2.9	60	88.8	0.80	17.0	0.08	0.825	390
ARC 225 MX8 TU	14.0	180					540	3.0						0.920	440
ARC 250 S8 TU	17.5	226	30.5	740	90.5	0.73	590	2.6	72	89.8	0.81	18.5	0.07	1.350	510
ARC 250 M8 TU	22.0	284	38.0	740	90.5	0.74	715	2.5	95	90.7	0.77	24.0	0.07	1.550	560
ARC 280 S8 TU	28.0	359	49.5	745	92.0	0.71	1040	2.9	152	91.8	0.79	30.0	0.06	2.63	780
ARC 280 M8 TU	35.0	449	61.0	745	93.0	0.71	1320	2.9	200	91.6	0.81	40.0	0.06	3.33	855
ARC 280 MX8 TU	37.0	474	65.5	746	92.0	0.71	1685	3.6	232	92.3	0.80	60.0	0.05	3.60	890
ARC 315 M8 TU	55.0	710	90.5	741	93.6	0.75	2100	3.0	245	91.1	0.82	57.0	0.05	6.000	1050
ARC 315 L8 TU	68.0	875	117.0	745	94.4	0.71	2140	2.4	248	94.1	0.82	75.0	0.05	6.760	1250
ARC 315 LX8 TU	85.0	1090	141.0	745	93.0	0.75	2724	2.5	308	92.0	0.82	73.5	0.06	8.710	1460
ARC 355 M8 TU	90.0	1154	149.0	745	94.0	0.74	3461	3.0	416	93.5	0.80	79.0	0.05	9.500	1600
ARC 355 MX8 TU	110.0	1410	183.0	745	94.0	0.74	4230	3.0	504	94.0	0.80	96.0	0.05	13.400	2200
ARC 400 L8 TU	170.0	2176		746	upon request		6450							32.000	3120
ARC 400 LX8 TU	200.0	2560		746	upon request		7750							39.000	3460

Synchronous speed 600 rpm – 10-pole version															
ARC 112 M10 TU	0.45	8		570	upon request		22	2.7						0.018	46
ARC 112 MX10 TU	0.61	10		575	upon request		28	2.8						0.023	60
ARC 112 MZ10 TU	0.70	12		570	upon request		33	2.8						0.029	62
ARC 132 S10 TU	1.0	17		575	upon request		46	2.7						0.043	90
ARC 132 M10 TU	1.30	22		575	upon request		60	2.5						0.053	95
ARC 132 MX10 TU	1.6	27		575	upon request		67	2.5						0.066	110
ARC 160 S10 TU	2.8	46		575	upon request		115	2.5						0.113	120
ARC 160 M10 TU	3.00	50	8.7	575	80.0	0.62	120	2.4	18	80.0	0.75	6.5	0.11	0.145	145
ARC 160 L10 TU	4.0	66		575	upon request		165	2.5						0.166	155
ARC 180 S10 TU	4.50	73	15.5	590	82.0	0.50	225	3.0	33	82.0	0.75	12.5	0.07	0.228	180
ARC 180 M10 TU	6.50	105	22.0	590	83.5	0.51	315	3.0	47	80.0	0.76			0.268	215
ARC 180 L10 TU	7.00	116	20.5	575	83.0	0.59	300	2.6	44	81.5	0.75	16.0	0.09	0.324	340
ARC 200 M10 TU	8.5	140		580	upon request		380	2.7						0.443	315
ARC 200 L10 TU	9.0	148		580	upon request		400	2.7						0.514	330
ARC 225 M10 TU	11.0	178	33.0	590	86.5	0.56	480	2.7	84	85.5	0.73	23.5	0.07	0.825	390
ARC 225 MX10 TU	12.0	198		580	upon request		535	2.7						0.920	440
ARC 250 S10 TU	13.5	220		585	upon request		595	2.7						1.280	510
ARC 250 M10 TU	17.0	278		585	upon request		750	2.7						1.480	560
ARC 280 S10 TU	22.5	364		590	upon request		980	2.7						2.630	780
ARC 280 M10 TU	27.5	445		590	upon request		1200	2.7						3.330	855
ARC 280 MX10 TU	37.5	607		590	upon request		1640	2.7						3.600	935
ARC 315 M10 TU	45.0	722	143.0	595	92.5	0.49	2190	3.0	295	93.0	0.70			6.000	1050
ARC 315 L10 TU	55.0	890		590	upon request		2670	3.0						6.670	1250
ARC 315 LX10 TU				590	upon request									6.670	1460
ARC 355 M10 TU	68.0	1091		595	upon request		3274	3.0						9.500	1600
ARC 355 MX10 TU	80.0	1284		595	upon request		3852	3.0						13.400	2200

Three-phase roller table motors with squirrel-cage rotor für use on a frequency converter, series ARC

Non-ventilated with surface cooling, IC 410

Planning data for switched operation calculations/motor preselection

Duty type S9, thermal class F, degree of protection IP 55, rated frequency 50 Hz

Insulation system for \hat{u} max. 1.8 kV; du/dt max. 5 kV/ μ s

ARC	Equivalent S1 output						Transient peak load (max. 10 s)					No load			
	P_{eff} (S1) kW	M_{eff} Nm	I_B 500 V A	n_B rpm	η_B referred to P_{eff} %	$\cos\varphi_B$ -	M_{max} Nm	M_{max}/M_{eff}	I_{max} A	η_{max} referred to M_{max} %	$\cos\varphi_{max}$ -	I_0 A	$\cos\varphi_0$ -	J kgm ²	m kg
	Synchronous speed 500 rpm – 12-pole version														
ARC 112 M12 TU	0.3	6		475	upon request		16	2.7						0.018	46
ARC 112 MX12 TU	0.5	10		470	upon request		27	2.7						0.023	60
ARC 112 MZ12 TU	0.6	12		470	upon request		33	2.8						0.029	62
ARC 132 S12 TU	0.8	16		480	upon request		43	2.7						0.043	90
ARC 132 M12 TU	1.0	20		480	upon request		54	2.7						0.053	95
ARC 132 MX12 TU	1.2	24		485	upon request		65	2.7						0.053	110
ARC 160 S12 TU	1.5	30		475	upon request		80	2.7						0.113	120
ARC 160 M12 TU	2.75	54	10.5	488	71.0	0.42	160	3.0	24	79.5	0.64	12.6	0.10	0.145	145
ARC 160 L12 TU	3.0	60		480	upon request		160	2.7						0.166	155
ARC 180 S12 TU	3.0	60		480	upon request		160	2.7						0.228	180
ARC 180 M12 TU	4.5	90	17.0	480	76.5	0.40	270	3.0	33			20.0	0.08	0.268	215
ARC 180 L12 TU	5.5	109	19.0	480	81.5	0.41	330	3.0	70			19.5	0.07	0.324	340
ARC 200 M12 TU	6.5	129		480	upon request		350	2.7						0.443	315
ARC 200 L12 TU	7.0	139		480	upon request		375	2.7						0.514	330
ARC 225 M12 TU	8.5	169	28.0	480	81.0	0.43	510	3.0	67			32.5	0.07	0.825	390
ARC 225 MX12 TU	9.0	179		480	upon request		480	2.7						0.920	440
ARC 250 S12 TU	10.0	199		480	upon request		535	2.7						1.280	510
ARC 250 M12 TU	12.0	232	39.0	495	84.5	0.42	625	2.7						1.480	560
ARC 280 S12 TU	18.5	364		485	upon request		985	2.7						2.630	780
ARC 280 M12 TU	22.5	443		485	upon request		1195	2.7						3.330	855
ARC 280 MX12 TU	27.5	541		485	upon request		1460	2.7						3.600	935
ARC 315 M12 TU	37.5	738		485	upon request		1995	2.7						6.000	1050
ARC 315 L12 TU				485	upon request									6.670	1250
ARC 315 LX12 TU	45	886		485	upon request		2390	2.7						6.670	1460
ARC 355 M12 TU	55	1072		490	upon request		2895	2.7						9.500	1600
ARC 355 MX12 TU	66	1286		490	upon request		3475	2.7						13.400	2200
ARC 400 L12 TU	110.00	2110	240	497	93.0	0.57	6000	2.8	630	93.5	0.74	215.0	0.04	37.000	3000
ARC 400 LX12 TU	132.00	2550	287	497	93.0	0.57	7320	2.9	770	92.4	0.75	260.0	0.04	45.000	3320

Three-phase roller table motors with squirrel-cage rotor für use on a frequency converter, series ARC

Non-ventilated with surface cooling, IC 410
 Planning data for switched operation calculations/motor preselection
 Duty type S9, thermal class F, degree of protection IP 55, rated frequency 50 Hz
 Insulation system for \hat{u} max. 2.5 kV; du/dt max. 5 kV/ μ s

ARC	Equivalent S1 output						Transient peak load (max. 10 s)					No load			
	P_{eff} (S1) kW	M_{eff} Nm	I_{B} 690 V A	n_{B} rpm	η_{B} referred to P_{eff} %	$\cos\varphi_{\text{B}}$ -	M_{max} Nm	$M_{\text{max}}/M_{\text{eff}}$	I_{max} A	η_{max} referred to M_{max} %	$\cos\varphi_{\text{max}}$ -	I_0 A	$\cos\varphi_0$ -	J kgm ²	m kg
Synchronous speed 1500 rpm – 4-pole version															
ARC 112 M4 TV	1.5	10	1.8	1470	82.0	0.85	27	2.8	5	69.5	0.90	1.1	0.13	0.015	56
ARC 112 MX4 TV	1.9	12		1478			43	3.5						0.017	63
ARC 112 MZ4 TV	2.3	15		1475			52	3.5						0.020	67
ARC 132 S4 TV	2.5	16	3.4	1477	82.0	0.76	49	3.0	10	75.0	0.89	2.0	0.14	0.028	82
ARC 132 M4 TV	3.5	23	4.4	1477	84.5	0.78	70	3.1	12	80.0	0.90	2.6	0.12	0.035	95
ARC 132 MX4 TV	4.4	28		1475			90	3.2						0.044	105
ARC 160 S4 TV	4.4	28	5.4	1480	86.0	0.80	90	3.2	16	84.0	0.85	3.2	0.15	0.078	130
ARC 160 M4 TV	5.5	35	6.7	1480	87.5	0.79	105	3.0	19	85.0	0.85	3.5	0.13	0.090	144
ARC 160 MX4 TV	6.5	42	8.0	1480	87.0	0.78	125	3.0	23	83.0	0.83	4.5	0.12	0.104	150
ARC 160 L4 TV	7.5	48	8.6	1480	87.0	0.84	150	3.1	26	86.0	0.84	4.0	0.16	0.116	170
ARC 180 S4 TV	8.0	51	9.5	1485	90.0	0.78	160	3.1	28	87.0	0.85	5.0	0.08	0.138	170
ARC 180 M4 TV	10.0	64	12.0	1485	89.0	0.78	190	3.0	33	87.0	0.85	7.0	0.10	0.168	215
ARC 180 L4 TV	12.0	77		1480			230	3.0						0.203	250
ARC 200 M4 TV	14.0	90	15.5	1485	91.5	0.82	270	3.0	46	88.0	0.85	7.5	0.09	0.275	270
ARC 200 L4 TV	15.0	96	16.5	1485	92.0	0.82	285	3.0	49	88.0	0.84	8.0	0.09	0.313	335
ARC 200 LX4 TV	18.5	119	22.0	1490	90.0	0.79	365	3.1	64	88.0	0.84	10.5	0.10	0.356	350
ARC 225 M4 TV	20.0	129	22.5	1485	92.0	0.81	380	3.0	67	89.0	0.84	10.5	0.08	0.525	375
ARC 225 MX4 TV	22.0	141		1485			425	3.0						0.638	420
ARC 250 S4 TV	25.0	160	29.0	1490	92.5	0.78	480	3.0	85	91.0	0.79	13.0	0.09	0.950	520
ARC 250 M4 TV	32.0	205	38.5	1490	93.0	0.75	624	3.0	110	92.5	0.79	19.0	0.07	1.100	580
ARC 280 S4 TV	40.0	256	45.5	1490	93.0	0.79	778	3.0	139	93.0	0.80	22.5	0.06	1.960	830
ARC 280 M4 TV	50.0	320	55.0	1490	93.5	0.81	968	3.0	175	92.0	0.78	24.0	0.07	2.270	895
ARC 280 MX4 TV	60.0	385	68.5	1490	93.0	0.79	1169	3.0	199	91.0	0.85	34.0	0.06	2.730	1015
ARC 315 M4 TV	70.0	449	72.5	1490	95.0	0.85	1330	3.0	280	93.0	0.80	25.5	0.07	4.820	1300
ARC 315 L4 TV	95.0	607	98.0	1495	95.5	0.85	1780	2.9	310	93.0	0.80	30.0	0.06	5.930	1450
ARC 315 LX4 TV	110.0	705	112.0	1490	95.5	0.86	2040	2.9	350	93.0	0.81	36.0	0.06	6.820	1630
ARC 355 M4 TV	132.0	843	134.0	1495	95.5	0.86	2530	3.0	430	84.5	0.80	56.0	0.06	10.000	2500
ARC 400 L4 TV	150.0	959		1494	upon request		6340	4.1						20.000	3210
ARC 400 LX 4 TV	160.0	1023		1494	upon request		7500	4.0						25.000	3460
Synchronous speed 1000 rpm – 6-pole version															
ARC 112 M6 TV	1.0	10	1.9	980	68.5	0.63	27	2.7	5	63.0	0.87	1.7	0.15	0.018	52
ARC 112 MX6 TV	1.3	13	2.3	980	73.0	0.64	38	3.0	6	65.0	0.87	1.9	0.13	0.023	60
ARC 112 MZ6 TV	1.7	17		975			43	2.6						0.029	62
ARC 132 S6 TV	2.2	21	3.5	985	77.0	0.68	66	3.1	10	69.0	0.83	2.7	0.13	0.043	90
ARC 132 M6 TV	2.6	25	3.8	980	78.0	0.73	79	3.1	11	71.0	0.85	2.6	0.16	0.053	95
ARC 132 MX6 TV	3.5	34	5.1	975	81.5	0.71	103	3.0	14	73.5	0.84	3.5	0.12	0.066	110
ARC 160 S6 TV	4.2	41	5.9	980	82.0	0.73	130	3.2	17	76.0	0.87	3.8	0.13	0.113	120
ARC 160 M6 TV	4.8	47	7.0	985	82.0	0.70	145	3.1	18	80.0	0.87	4.3	0.15	0.145	145
ARC 160 L6 TV	5.5	54	7.4	980	83.5	0.74	160	3.0	20	80.0	0.88	4.0	0.15	0.166	155
ARC 180 S6 TV	7.0	68	8.8	985	84.5	0.79	205	3.0	25	80.0	0.88	4.2	0.13	0.228	180
ARC 180 M6 TV	7.6	74	9.4	985	85.0	0.80	228	3.1	27	79.5	0.88	5.6	0.13	0.268	215
ARC 180 L6 TV	8.5	82	10.5	985	85.0	0.80	250	3.0	31	77.0	0.88	6.3	0.12	0.324	340
ARC 200 M6 TV	11.0	107	13.5	985	86.0	0.80	320	3.0	37	84.0	0.88	7.0	0.13	0.443	315
ARC 200 L6 TV	12.5	121	14.5	985	88.0	0.82	373	3.1	43	83.0	0.88	7.5	0.13	0.514	330
ARC 200 LX6 TV	15.0	145	17.0	985	88.0	0.85	450	3.1	66	83.0	0.88	12.0	0.11	0.620	360
ARC 225 M6 TV	15.0	145	17.5	990	89.0	0.81	450	3.1	55	84.0	0.85	9.0	0.09	0.825	390
ARC 225 MX6 TV	16.5	159		990			535	3.4						0.920	440
ARC 250 S6 TV	22.0	212	34.5	991	91.0	0.81	540	2.5	88	90.7	0.88		0.08	1.280	465
ARC 250 M6 TV	27.0	260	41.5	991	92.0	0.82	706	2.7	112	91.3	0.88	22.0	0.08	1.480	520
ARC 280 S6 TV	37.0	356	57.5	992	94.0	0.79	1075	3.0	184	93.1	0.88	27.0	0.05	2.630	780
ARC 280 M6 TV	44.0	424	66.5	992	93.5	0.82	1265	3.0	208	92.5	0.87	34.0	0.07	3.330	855
ARC 280 MX6 TV	48.0	461	72.5	995	93.5	0.82	1608	3.5	256	92.5	0.86	37.5	0.07	3.600	890
ARC 315 M6 TV	75.0	721	110.0	993	94.5	0.83	1945	2.7	304	93.9	0.87	46.0	0.06	6.000	1050
ARC 315 L6 TV	90.0	866	131.0	993	94.5	0.84	2140	2.5	360	93.0	0.88	51.0	0.08	6.670	1250
ARC 315 LX6 TV	100.0	962	146.0	993	95.0	0.83	2800	2.9	433	94.0	0.87	60.0	0.06	8.600	1460
ARC 355 M6 TV	140.0	1344	210.0	995	96.0	0.80	4031	3.0	652	94.5	0.80	100.0	0.05	8.200	1650
ARC 355 MX6 TV	160.0	1536	241.0	995	96.0	0.80	4607	3.0	708	96.5	0.80	123.0	0.04	12.800	2200
ARC 400 L6 TV	210.0	2030		995	upon request		6400	3.2						25.000	3120
ARC 400 LX6 TV	240.0	2310		995	upon request		7460	3.2						27.000	3340

Three-phase roller table motors with squirrel-cage rotor für use on a frequency converter, series ARC

Non-ventilated with surface cooling, IC 410

Planning data for switched operation calculations/motor preselection

Duty type S9, thermal class F, degree of protection IP 55, rated frequency 50 Hz

Insulation system for \hat{u} max. 2.5 kV; du/dt max. 5 kV/ μ s

ARC	Equivalent S1 output						Transient peak load (max. 10 s)					No load			
	P_{eff} (S1) kW	M_{eff} Nm	I_B 690 V A	n_B rpm	η_B referred to P_{eff} %	$\cos\varphi_B$ -	M_{max} Nm	M_{max}/M_{eff}	I_{max} A	η_{max} referred to M_{max} %	$\cos\varphi_{max}$ -	I_0 A	$\cos\varphi_0$ -	J kgm ²	m kg
Synchronous speed 750 rpm – 8-pole version															
ARC 112 M8 TV					upon request									0.018	46
ARC 112 MX8 TV					upon request									0.023	53
ARC 112 MZ8 TV					upon request									0.029	62
ARC 132 S8 TV					upon request									0.043	90
ARC 132 M8 TV					upon request									0.053	95
ARC 132 MX8 TV					upon request									0.066	110
ARC 160 S8 TV	3.0	39	4.5	735	82.0	0.68	110	2.8	12	81.0	0.78	3.7	0.10	0.113	120
ARC 160 M8 TV	3.6	47	5.6	736	82.0	0.66	117	2.5	12	81.5	0.80	4.1	0.11	0.145	145
ARC 160 L8 TV	4.0	52		735			140	2.7						0.166	155
ARC 180 S8 TV	5.5	71	8.7	740	83.0	0.64	210	3.0	21	79.0	0.82	6.5	0.11	0.228	190
ARC 180 M8 TV	6.5	84	9.5	735	83.0	0.69	240	2.8	22	80.0	0.85	6.5	0.09	0.268	215
ARC 180 L8 TV	7.5	97		740			316	3.2						0.324	340
ARC 200 M8 TV	8.0	103	11.0	740	86.0	0.70	325	3.1	29	83.0	0.84	7.5	0.09	0.443	315
ARC 200 L8 TV	9.0	116	12.0	740	88.0	0.70	390	2.9	33	84.0	0.85	8.5	0.08	0.514	330
ARC 225 M8 TV	13.0	167	22.5	743	86.3	0.78	480	2.9	60	88.8	0.80	17.0	0.08	0.825	390
ARC 225 MX8 TV	14.0	180					540	3.0						0.920	440
ARC 250 S8 TV	17.5	226	30.5	740	90.5	0.73	590	2.6	72	89.8	0.81	18.5	0.07	1.350	510
ARC 250 M8 TV	22.0	284	38.0	740	90.5	0.74	715	2.5	95	90.7	0.77	24.0	0.07	1.550	560
ARC 280 S8 TV	28.0	359	49.5	745	92.0	0.71	1040	2.9	152	91.8	0.79	30.0	0.06	2.63	780
ARC 280 M8 TV	35.0	449	61.0	745	93.0	0.71	1320	2.9	200	91.6	0.81	40.0	0.06	3.33	855
ARC 280 MX8 TV	37.0	474	65.5	746	92.0	0.71	1685	3.6	232	92.3	0.80	60.0	0.05	3.60	890
ARC 315 M8 TV	55.0	710	90.5	741	93.6	0.75	2100	3.0	245	91.1	0.82	57.0	0.05	6.000	1050
ARC 315 L8 TV	68.0	875	117.0	745	94.4	0.71	2140	2.4	248	94.1	0.82	75.0	0.05	6.760	1250
ARC 315 LX8 TV	85.0	1090	141.0	745	93.0	0.75	2724	2.5	308	92.0	0.82	73.5	0.06	8.710	1460
ARC 355 M8 TV	90.0	1154	149.0	745	94.0	0.74	3461	3.0	416	93.5	0.80	79.0	0.05	9.500	1600
ARC 355 MX8 TV	110.0	1410	183.0	745	94.0	0.74	4230	3.0	504	94.0	0.80	96.0	0.05	13.400	2200
ARC 400 L8 TV	170.0	2176		746	upon request		6450							32.000	3120
ARC 400 LX8 TV	200.0	2560		746	upon request		7750							39.000	3460

Use of motor parameters for voltages and frequencies other than 400 V, 50 Hz

Operating point $U_B, f_B > f_n$

$$\begin{aligned}
 P_B &\approx P_{eff} \\
 n_B &\approx (f_B/50) \times n \\
 M_B &\approx (50/f_B) \times M_{eff} \\
 M_{B,max} &\approx (50/f_B) \times M_{max} \\
 I_{0,B} &\approx (400/U_B) \times (f_B/50) \times I_0 \\
 I_{n,B} &\approx (400/U_B) \times \sqrt{(f_B/50)} \times I_n \\
 I_{max,B} &\approx (400/U_B) \times (f_B/50) \times I_{max} \\
 \cos\varphi_{0,B} &\approx \cos\varphi_0 \\
 \cos\varphi_{n,B} &\approx \sqrt{(50/f_B)} \times \cos\varphi_{n,B} \\
 \cos\varphi_{max,B} &\approx \cos\varphi_{max}
 \end{aligned}$$

Operating point $U_B, f_B < f_n$

$$\begin{aligned}
 P_B &\approx (f_B/50) \times P_{eff} \\
 n_B &\approx (f_B/50) \times n \\
 M_B &\approx M_{eff} \\
 M_{B,max} &\approx M_{max} \\
 I_{0,B} &\approx (400/U_B) \times (f_B/50) \times I_0 \\
 I_{n,B} &\approx (400/U_B) \times (f_B/50) \times I_n \\
 I_{max,B} &\approx (400/U_B) \times (f_B/50) \times I_{max} \\
 \cos\varphi_{0,B} &\approx \cos\varphi_0 \\
 \cos\varphi_{n,B} &\approx \cos\varphi_{n,B} \\
 \cos\varphi_{max,B} &\approx \cos\varphi_{max}
 \end{aligned}$$

Parameters:

P_{eff} [kW]	Effective power output (equivalent S1 output)
M_{eff} [Nm]	Effective torque
I_n [A]	Current at equivalent S1 output
n_n [rpm]	Speed at equivalent S1 output
η_n [%]	Efficiency at equivalent S1 output
$\cos\varphi_n$ [rpm]	Power factor at equivalent S1 output
M_k/M_n [-]	Relative breakdown torque
M_{max} [Nm]	Max. acceleration torque
M_{max}/M_{eff} [-]	Max. acceleration torque relative to effective torque
η_{max} [%]	Efficiency at max. acceleration torque
$\cos\varphi_{max}$ [-]	Power factor at max. acceleration torque
I_0 [A]	No-load current
$\cos\varphi_0$ [-]	No-load power factor

Depending on the motor type, the increasing iron losses at frequencies above 50 Hz may lead to a greater temperature rise in the windings and thus necessitate an output reduction.

Three-phase roller table motors with squirrel-cage rotor für use on a frequency converter, series ARC

Non-ventilated with surface cooling, IC 410

Planning data for switched operation calculations/motor preselection

Duty type S9, thermal class F, degree of protection IP 55, rated frequency 50 Hz

ARC	Transient peak load (max. 10 s)												J	m
	50 Hz			40 Hz			30 Hz			20 Hz				
	M _{eff} Nm	M _{max} Nm	I _{eff} 400 V A	M _{eff} Nm	M _{max} Nm	I _{eff} 400 V A	M _{eff} Nm	M _{max} Nm	I _{eff} 400 V A	M _{eff} Nm	M _{max} Nm	I _{eff} 400 V A		
Synchronous speed	1500 rpm			1200 rpm			900 rpm			600 rpm				
ARC 112 M4	15	47	4.7	16	49	4.0	17	52	3.2	18	56	2.3	0.015	56
ARC 112 MX4	16	49		17	51		18	54		19	59		0.017	63
ARC 112 MZ4	20	60		21	63		22	66		24	72		0.020	67
ARC 132 S4	19	61	6.6	20	64	5.5	21	67	4.3	23	73	3.1	0.028	82
ARC 132 M4	28	93	9.2	29	98	7.5	31	102	6.0	34	112	4.4	0.035	95
ARC 132 MX4	40	120		42	126		44	132		48	144		0.044	105
ARC 160 S4	35	105	11.5	36	110	9.2	39	116	7.4	42	126	5.3	0.078	130
ARC 160 M4	50	150	16.0	52	158	13.2	55	165	10.5	60	180	7.6	0.090	144
ARC 160 MX4	52	160	16.5	54	168	13.9	57	176	11.0	62	192	8.0	0.104	150
ARC 160 L4	66	200	20.0	69	210	16.8	73	220	13.3	79	240	9.6	0.116	170
ARC 180 S4	57	175	18.5	59	184	15.3	63	193	12.3	68	210	8.8	0.138	170
ARC 180 M4	71	215	22.0	74	226	18.4	78	237	14.5	85	258	10.5	0.168	215
ARC 180 MX4	90	270		94	284		99	297		108	324		0.203	250
ARC 200 M4	100	307	29.5	104	322	25.5	110	338	20.2	120	368	14.7	0.275	270
ARC 200 L4	119	367	35.0	124	385	29.5	131	404	23.3	143	440	17.0	0.313	335
ARC 200 LX4	128	380	39.5	133	399	32.7	141	418	26.0	154	456	19.0	0.356	350
ARC 225 M4	141	425	43.0	147	446	35.9	155	468	28.4	169	510	20.6	0.525	375
ARC 225 MX4	161	480		167	504		177	528		193	576		0.638	420
ARC 250 S4	205	624	59.0	213	655	49.1	226	686	39.0	246	749	28.3	0.950	520
ARC 250 M4	257	778	73.0	267	817	60.6	283	856	48.2	308	934	35.0	1.100	580
ARC 280 S4	319	968	102.0	332	1016	84.5	351	1065	67.0	383	1162	48.7	1.960	830
ARC 280 M4	384	1169	117.0	399	1227	96.9	422	1286	76.9	461	1403	56.0	2.270	895
ARC 280 MX4	449	1330	136.0	467	1397	113.3	494	1463	89.9	539	1596	65.4	2.730	1015
ARC 315 M4	607	1780	172.0	631	1869	143.1	668	1958	113.7	728	2136	82.6	4.820	1300
ARC 315 L4	845	2040	239.0	879	2142	199.0	930	2244	157.9	1014	2448	114.8	5.930	1450
ARC 315 LX4	961	2884	268.0	1000	3028	223.4	1058	3172	177.3	1154	3461	128.9	6.820	1630
ARC 355 M4	1022	3066	291.0	1063	3219	243.7	1124	3373	193.3	1226	3679	140.5	10.000	2500
ARC 400 L4	1534	6340	415.0	1596	6657	344.8	1688	6974	273.5	1841	7608	198.9	20.000	3210
ARC 400 LX4	1854	7500	500.0	1928	7875	416.1	2039	8250	330.1	2224	9000	240.0	25.000	3460
Synchronous speed	1000 rpm			800 rpm			600 rpm			400 rpm				
ARC 112 M6	15	45	4.1	15	47	3.3	16	50	2.7	18	54	2.0	0.018	52
ARC 112 MX6	19	57	4.6	19	60	3.7	20	63	3.0	22	68	2.2	0.023	60
ARC 112 MZ6	22	66		22	69		24	73		26	79		0.029	62
ARC 132 S6	25	79	6.3	26	83	5.2	28	87	4.2	30	95	3.0	0.043	90
ARC 132 M6	34	103	9.3	35	108	7.6	38	113	6.2	41	124	4.5	0.053	95
ARC 132 MX6	41	130	10.5	43	137	8.6	45	143	6.8	49	156	4.9	0.066	110
ARC 160 S6	47	145	11.0	49	152	9.1	51	160	7.1	56	174	5.2	0.113	120
ARC 160 M6	63	195	14.0	66	205	11.6	70	215	9.2	76	234	6.7	0.145	145
ARC 160 L6	68	205		71	215		75	226		82	246		0.166	155
ARC 180 S6	74	228	15.0	77	239	12.6	81	251	10.0	88	274	7.2	0.228	180
ARC 180 M6	92	283	19.5	96	297	16.4	101	311	12.9	111	340	9.5	0.268	215
ARC 180 MX6	107	320		111	336		117	352		128	384		0.324	340
ARC 200 M6	121	373	25.0	126	392	20.7	133	410	16.4	145	448	11.9	0.443	315
ARC 200 L6	145	450	30.0	151	473	25.1	160	495	20.0	175	540	14.6	0.514	330
ARC 200 LX6	189	580	37.0	197	609	31.0	208	638	24.6	227	696	17.9	0.620	360
ARC 225 M6	159	496	33.0	166	521	27.6	175	546	21.9	191	595	15.9	0.825	390
ARC 225 MX6	174	535		181	562		191	589		208	642		0.920	440
ARC 250 S6	212	540	43.0	220	567	35.9	233	594	28.5	254	648	20.7	1.280	465
ARC 250 M6	260	706	51.5	271	741	43.0	286	777	34.1	312	847	24.8	1.480	520
ARC 280 S6	356	1075	71.5	370	1129	59.5	392	1183	47.3	427	1290	34.4	2.630	780
ARC 280 M6	424	1265	83.0	441	1328	69.0	466	1392	54.7	508	1518	39.7	3.330	855
ARC 280 MX6	461	1608	90.5	479	1688	75.2	507	1769	59.7	553	1930	43.4	3.600	935
ARC 315 M6	721	1945	138.0	750	2042	114.8	793	2140	91.0	866	2334	66.3	6.000	1050
ARC 315 L6	866	2140	167.0	900	2247	139.2	952	2354	110.4	1039	2568	80.3	6.670	1250
ARC 315 LX6	960	2800	191.0	998	2940	158.8	1056	3080	126.0	1152	3360	91.7	8.600	1460
ARC 355 M6	1344	4031	263.0	1397	4233	218.8	1478	4434	173.6	1612	4837	126.3	8.200	1650
ARC 355 MX6	1536	4607	301.0	1597	4837	250.2	1689	5068	198.4	1843	5528	144.4	12.800	2200
ARC 400 L6	2030	6400	380.0	2111	6720	319.4	2233	7040	253.4	2436	7680	184.3	25.000	3120
ARC 400 LX6	2310	7460	440.0	2402	7833	367.9	2541	8206	291.9	2772	8952	212.3	27.000	3340

Three-phase roller table motors with squirrel-cage rotor für use on a frequency converter, series ARC

Non-ventilated with surface cooling, IC 410

Planning data for switched operation calculations/motor preselection

Duty type S9, thermal class F, degree of protection IP 55, rated frequency 50 Hz

ARC	Transient peak load (max. 10 s)												J	m
	50 Hz			40 Hz			30 Hz			20 Hz				
	M _{eff} Nm	M _{max} Nm	I _{eff} 400 V A	M _{eff} Nm	M _{max} Nm	I _{eff} 400 V A	M _{eff} Nm	M _{max} Nm	I _{eff} 400 V A	M _{eff} Nm	M _{max} Nm	I _{eff} 400 V A		
Synchronous speed	750 rpm			600 rpm			450 rpm			300 rpm				
ARC 112 M8	14	38	4.1	15	40	3.4	16	42	2.7	17	46	1.9	0.018	46
ARC 112 MX8	20	54	4.7	20	57	3.8	21	59	3.0	23	65	2.2	0.023	60
ARC 112 MZ8	22	65		23	68		24	72		26	78		0.029	62
ARC 132 S8	24	57	5.3	24	60	4.4	26	63	3.5	28	68	2.5	0.043	90
ARC 132 M8	33	87	9.0	34	91	7.5	36	96	5.9	39	104	4.3	0.053	95
ARC 132 MX8	39	110		41	116		43	121		47	132		0.066	110
ARC 160 S8	47	117	9.2	49	123	7.7	52	129	6.1	56	140	4.4	0.113	120
ARC 160 M8	65	174	12.5	68	183	10.5	72	191	8.3	78	209	6.0	0.145	145
ARC 160 L8	95	255		99	268		105	281		114	306		0.166	155
ARC 180 S8	84	257	16.5	87	270	13.6	92	283	10.8	101	308	7.9	0.228	180
ARC 180 M8	97	316	19.5	101	332	16.2	107	348	12.8	116	379	9.3	0.268	215
ARC 180 MX8	103	325		107	341		113	358		124	390		0.324	340
ARC 200 M8	116	390	20.5	121	410	17.2	128	429	13.6	139	468	9.9	0.443	315
ARC 200 L8	143	410	22.5	149	431	19.0	157	451	15.0	172	492	10.9	0.514	330
ARC 225 M8	167	480	28.0	174	504	23.2	184	528	18.4	200	576	13.3	0.825	390
ARC 225 MX8	180	540		187	567		198	594		216	648		0.920	440
ARC 250 S8	226	590	38.0	235	620	31.8	249	649	25.3	271	708	18.4	1.350	510
ARC 250 M8	284	715	47.5	295	751	39.4	312	787	31.3	341	858	22.8	1.550	560
ARC 280 S8	359	1040	62.0	373	1092	51.4	395	1144	40.9	431	1248	29.7	2.63	780
ARC 280 M8	449	1320	76.5	467	1386	63.7	494	1452	50.5	538	1584	36.7	3.33	855
ARC 280 L8	474	1685	82.0	493	1769	68.1	521	1854	54.0	568	2022	39.2	3.60	935
ARC 315 M8	710	2100	113.0	738	2205	94.2	781	2310	74.8	852	2520	54.4	6.000	1050
ARC 315 L8	875	2140	145.0	910	2247	122.3	963	2354	97.1	1050	2568	70.6	6.760	1250
ARC 315 LX8	1090	2724		1133	2860		1199	2996		1308	3269		8.710	1460
ARC 355 M8	1154	3461	145.0	1200	3634	155.4	1269	3807	123.2	1384	4153	89.6	9.500	1600
ARC 355 MX8	1410	4230	145.0	1466	4442	189.8	1551	4653	150.6	1692	5076	109.6	13.400	2200
ARC 400 L8	2176	6450	345.0	2263	6773	286.5	2394	7095	227.3	2612	7740	165.3	32.000	3120
ARC 400 LX8	2560	7750	405.0	2663	8138	336.8	2816	8525	267.1	3072	9300	194.2	39.000	3460

Bearings

Series ARC

Type	D-end								N-end	
	Anti-friction bearing	γ-ring	Radial shaft seal 1	Sealing grease amount in g	Radial shaft seal 2	Bushing	Bushing	Disc spring	Anti-friction bearing	Fixed bearing
ARC 112 M, MX	6207 C3	9RB 35 FKM	40 x 62 x 7	-	-	IR 35 x 40 x 17 EGS	72	-	6207 C3	N-end
ARC 132 S, M	6308 C3	9RB 40 FKM	45 x 65 x 8	50	-	IR 40 x 45 x 17 EGS	90	-	6308 C3	
ARC 160 S, M	6310 C3	9RB 50 FKM	55 x 75 x 7	70	55 x 85 x 8	IR 50 x 55 x 20 EGS	110	-	6309 C3	
ARC 180 S, M	6312 C3	9RB 60 FKM	70 x 90 x 7	80	70 x 100 x 10	IR 60 x 70 x 25 EGS	-	130	6310 C3	
ARC 200 S, M, L, LX	6313 C3	9RB 65 FKM	72 x 95 x 10	90	72 x 100 x 10	IR 65 x 72 x 25 EGS	-	140	6312 C3	
ARC 225 M	6314 C3	9RB 70 FKM	80 x 100 x 7	100	80 x 110 x 10	IR 70 x 80 x 30 EGS	-	150	6313 C3	
ARC 250 S, M	6316 C3	9RB 80 FKM	90 x 110 x 7.5	110	90 x 120 x 12	IR 80 x 90 x 30 EGS	-	170	6314 C3	
ARC 280 S, M	6317 C3	9RB 85 FKM	95 x 120 x 12	120	95 x 125 x 12	IR 85 x 90 x 36 EGS	-	180	6316 C3	
ARC 315 M, MX	6320 C3	9RB 95 FKM	105 x 130 x 12	130	105 x 140 x 12	IR 95 x 105 x 36 x EGS	215	6317 C3		
ARC 315 L, LX										
ARC 355 M, MX, LY, L	6324 C3	9RB 110 FKM	125 x 150 x 15	150	125 x 160 x 12	IR 110 x 125 x 40 EGS	-	260	6317 C3	
ARC 400 L, LX	6324 C3	9RB 110 FKM	125 x 150 x 15	150	125 x 160 x 12	IR 110 x 125 x 40 EGS	-	260	6321 C3	

Lubricating grease Berutox FH28KN (KHC1R-30 DIN 51825)

^{*)} Special version with insulated bearing on N-end

Series ARB

Type	Anti-friction bearing D-end and N-end	Fixed bearing
ARB 22, ARB 33	6306 S1 C5	N-end
ARB 54, ARB 65	6306 S1 C5	N-end

Lubricating grease Berutox FH28KN (KHC1R-30 DIN 51825)

Limit speeds

If motors are operated at above the rated speed, the limit values of the anti-friction bearings, the strength of the rotating parts, critical rotor speeds and the circumferential speed of the fans must be observed.

The limit speeds specified in the table below may already require precautionary measures such as special fans, special bearings or special balancing.

Type	Synchronous speed at 50 Hz		
	1500 rpm	1000 rpm	750 rpm
ARC 112	3600	2400	1800
ARC 132	3600	2400	1800
ARC 160	3000	2000	1500
ARC 180	3000	2000	1500
ARC 200	3000	2000	1500
ARC 225	3000	2000	1500
ARC 250	3000	2000	1500
ARC 280	3000	2000	1500
ARC 315	3000	2000	1500
ARC 355	3000	2000	1500
ARC 400	3000	2000	1500
ARB 22, 33	3600	2400	1800
ARB 54, 65	3000	2000	1500

Terminal boxes

Motor type	Terminal box	Material	Length	Width	Height	Standard cable gland	Max. cable diameter	Terminal mounting	Thread of terminal stud	Thread of protective conductor	Figure
			AG	LL	-	o	Ø max				
ARC 112	25 A	GG15	143	134	70	M32 x 1.5	Ø 21 mm	K1M5	M5	KB*	01
ARC 132	25 A	GG15	143	134	70	M32 x 1.5	Ø 21 mm	K1M5	M5	KB*	01
ARC 160	25 A	GG15	143	134	70	M32 x 1.5	Ø 21 mm	K1M5	M5	KB*	01
ARC 180	63 A	GG15	175	162	81	M40 x 1.5	Ø 28 mm	K1M6	M6	KB*	01
ARC 200	100 A	GG15	213	207	101	M50 x 1.5	Ø 35 mm	K1M8	M8	M8	01
ARC 225	100 A	GG15	213	207	101	M50 x 1.5	Ø 35 mm	K1M8	M8	M8	01
ARC 250	200 A	GG15	282	242	131	M63 x 1.5	Ø 45 mm	K1M10	M10	M10	01
ARC 280	200 A	GG15	282	242	131	M63 x 1.5	Ø 45 mm	K1M10	M10	M10	01
ARC 315	200 A	GG15	282	242	131	M63 x 1.5	Ø 45 mm	K1M10	M10	M10	01
ARC 355	400 A	GG15	311	297	152	M63 x 1.5	Ø 45 mm	KM12	M12	M10	02
ARC 400	400 B	GG15	415	340	176	M63 x 1.5	Ø 45 mm	KM16	M16	Tab	02
ARB		GG15	130	130		M32 x 1.5	Ø 21 mm	KBS6	M6	M6	non

KB* ... Terminal clamp

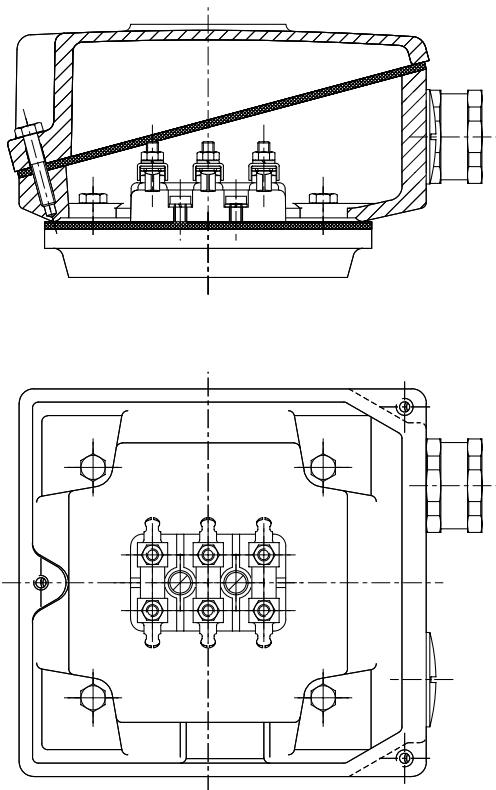

Figure 01

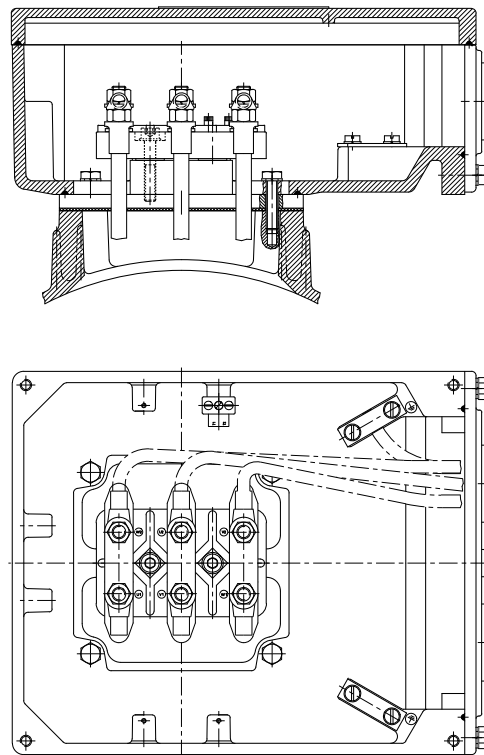

Figure 02

Dimensions

Notes concerning dimensions

Dimension designations in accordance with EN 50347 and IEC 60072
Flange sizes in the dimension tables are specified in accordance with DIN 42948.

VEM motors GmbH reserves the right to modify technical data without prior notice. The dimensions shown in catalogues may not be up to date. Binding dimensional data can be requested from the VEM sales organisation.

All dimensions in mm

Flange dimensions

Flanges with threaded holes

Flange type to E DIN EN 50347	Flange type to DIN 42948	LA c_1	M e_1	N b_1	P a_1	S s_1	T f_1
FT 65	C 80	6.5	65	50	80	M5	2.5
FT 75	C 90	8	75	60	90	M5	2.5
FT 85	C 105	8.5	85	70	105	M6	2.5
FT 100	C 120	8	100	80	120	M6	3
FT 115	C 140	10	115	95	140	M8	3
FT 130	C 160	10	130	110	160	M8	3.5
FT 165	C 200	12	165	130	200	M10	3.5
FT 215	C 250	12	215	180	250	M12	4

Flanges with through-holes

Flange type to E DIN EN 50 347	Flange type to DIN 42948	LA c_1	M e_1	N b_1	P a_1	S s_1	T f_1
FF 100	A 120	9	100	80	120	7	3
FF 115	A 140	9	115	95	140	9	3
FF 130	A 160	9	130	110	160	9	3.5
FF 165	A 200	10	165	130	200	11	3.5
FF 215	A 250	11	215	180	250	14	4
FF 265	A 300	12	265	230	300	14	4
FF 300	A 350	13	300	250	350	18	5
FF 350	A 400	15	350	300	400	18	5
FF 400	A 450	16	400	350	450	18	5
FF 500	A 550	18	500	450	550	18	5
FF 600	A 660	22	600	550	660	22	6
FF 740	A 800	25	740	680	800	22	6
FF 940	A1000	25	940	880	1000	28	6
FF 1080	A1150	32	1080	1000	1150	28	6

According to DIN EN 50347, the different sizes of FF flanges possess through-holes, while FT flanges possess threaded holes. The flange designations A and C defined in DIN 42948 remain valid.

Flange assignments which deviate from the standard are specified in the flange assignment tables.

For tolerances for the dimension N (b_1), refer to the corresponding dimension tables LA (c_1) depth of engagement

Three-phase roller table motors with squirrel-cage rotor

Series ARC

with surface cooling, type of cooling IC 410, degree of protection IP 55

Type of construction IM B3 [IM 1001]

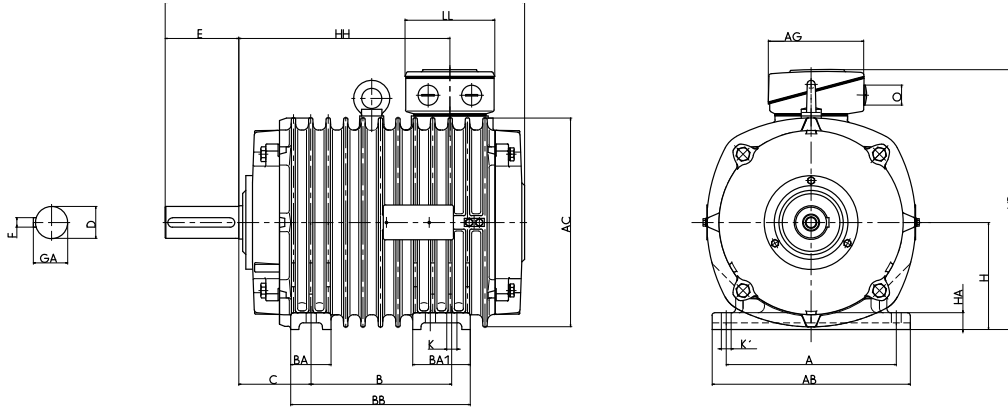

Type designation	- B5	A b	AB f	AC g	B a	BA m	BA1 m1	BB e	C w1	CA w2	D d	DA d1	DB ¹⁾ -	E l	EA l1
ARC 112 M	A300	190	226	217	140	55	55	190	70	170	32	32	M12	80	80
ARC 132 S	A350	216	256	258	140	60	87	232	89	216	38	38	M12	80	80
ARC 132 M	A350	216	256	258	178	60	87	232	89	178	38	38	M12	80	80
ARC 160 S	A350	254	296	313	178	60	87	268	108	152	48	42	M16	110	110
ARC 160 M	A350	254	296	313	210	60	87	268	108	120	48	42	M16	110	110
ARC 160 MX	A350	254	296	313	210	60	112	320	108	172	48	42	M16	110	110
ARC 160 L	A350	254	296	313	254	60	112	320	108	128	48	42	M16	110	110
ARC 180 S	A400	279	328	351	203	70	124	321	121	186	55	48	M20	110	110
ARC 180 M	A400	279	328	351	241	70	124	321	121	148	55	48	M20	110	110
ARC 180 L	A400	279	328	351	279	70	70	350	121	230	55	48	M20	110	110
ARC 200 M	A450	318	372	390	267	75	117	380	133	298	60	55	M20	140	110
ARC 200 L	A450	318	372	390	305	75	117	380	133	277	60	55	M20	140	110
ARC 225 M	A550	356	413	440	311	80	80	390	149	225	65	55	M20	140	110
ARC 250 S	A550	406	469	490	311	85	130	437	168	231	75	65	M20	140	140
ARC 250 M	A550	406	469	490	349	85	130	437	168	193	75	65	M20	140	140
ARC 280 S	A660	457	522	550	368	100	140	516	190	252	80	70	M20	170	140
ARC 280 M	A660	457	522	550	419	100	140	516	190	201	80	70	M20	170	140
ARC 315 M	A660	508	590	616	457	120	155	622	216	432	90	75	M24	170	140
ARC 315 L	A660	508	590	616	508	120	155	622	216	394	90	75	M24	170	140
ARC 355 MY	A800	610	700	715	560	125	163	733	254	386	100	80	M24	210	170
ARC 355 M	A800	610	700	715	560	125	163	733	254	386	100	80	M24	210	170
ARC 355 MX	A800	610	700	715	560	125	163	733	254	386	100	80	M24	210	170
ARC 355 L	A800	610	700	715	630	125	163	733	254	316	100	80	M24	210	170
ARC 400 L	A1000	686	810	800	710	212	293	1053	280	450	110	90	M24	210	170

¹⁾ Centre holes to DIN 332-DS

Three-phase roller table motors with squirrel-cage rotor

Series ARC

with surface cooling, type of cooling IC 410, degree of protection IP 55

Type of construction IM B35 [IM 2001]

Flange dimensions, see page 9/57

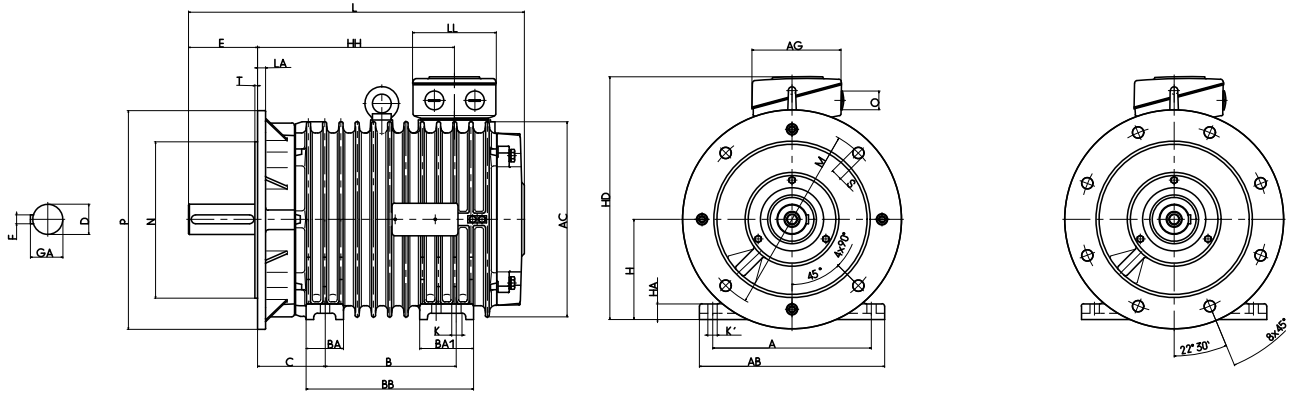

Type designation	F u	FA u1	GA t	GC t1	H h	HA c	HD p	K s	K' s'	L k	LC k1	TB Type	AG x	LL z	O	Hole pattern
ARC 112 M	10	10	35	35	112	18	292	12	12	450	540	25 A	143	134	M32 x 1.5	4L
ARC 132 S	10	10	41	41	132	20	332	12	12	515	605	25 A	143	134	M32 x 1.5	4L
ARC 132 M	10	10	41	41	132	20	332	12	12	515	605	25 A	143	134	M32 x 1.5	4L
ARC 160 S	14	12	51.5	45	160	25	390	15	15	540	658	25 A	143	134	M32 x 1.5	4L
ARC 160 M	14	12	51.5	45	160	25	390	15	15	540	658	25 A	143	134	M32 x 1.5	4L
ARC 160 MX	14	12	51.5	45	160	25	390	15	15	592	710	25 A	143	134	M32 x 1.5	4L
ARC 160 L	14	12	51.5	45	160	25	390	15	15	592	710	25 A	143	134	M32 x 1.5	4L
ARC 180 S	16	14	59	51.5	180	25	441	15	15	610	730	63 A	175	162	M40 x 1.5	4L
ARC 180 M	16	14	59	51.5	180	25	441	15	15	610	730	63 A	175	162	M40 x 1.5	4L
ARC 180 L	16	14	59	51.5	180	25	441	15	15	694	814	63 A	175	162	M40 x 1.5	4L
ARC 200 M	18	16	64	59	200	27	500	19	19	845	965	100 A	213	207	M50 x 1.5	8L
ARC 200 L	18	16	64	59	200	27	500	19	19	845	965	100 A	213	207	M50 x 1.5	8L
ARC 225 M	18	16	69	59	225	30	551	19	19	815	935	100 A	213	207	M50 x 1.5	8L
ARC 250 S	20	18	79.5	69	250	33	638	24	24	840	990	200 A	282	242	M63 x 1.5	8L
ARC 250 M	20	18	79.5	69	250	33	638	24	24	840	990	200 A	282	242	M63 x 1.5	8L
ARC 280 S	22	20	85	74.5	280	40	700	24	24	970	1120	200 A	282	242	M63 x 1.5	8L
ARC 280 M	22	20	85	74.5	280	40	700	24	24	970	1120	200 A	282	242	M63 x 1.5	8L
ARC 315 M	25	20	95	79.5	315	44	757	28	28	1275	1415	200 A	282	242	M63 x 1.5	8L
ARC 315 L	25	20	95	79.5	315	44	757	28	35	1275	1415	200 A	282	242	M63 x 1.5	8L
ARC 355 MY	28	22	106	85	355	50	915	28	35	1400	1580	400 A	311	294	M63 x 1.5	8L
ARC 355 M	28	22	106	85	355	50	915	28	35	1400	1580	400 A	311	294	M63 x 1.5	8L
ARC 355 MX	28	22	106	85	355	50	915	28	35	1400	1580	400 A	311	294	M63 x 1.5	8L
ARC 355 L	28	22	106	85	355	50	915	28	35	1400	1580	400 A	311	294	M63 x 1.5	8L
ARC 400 L	28	25	116	95	400	55	1006	35	35	1630	1820	400 B	415	340	M63 x 1.5	8L

Three-phase roller table motors with squirrel-cage rotor

Series ARC
with surface cooling, type of cooling IC 410, degree of protection IP 55

Type of construction IM B5 [IM 3001] to size 250

Type of construction IM V1 [IM 3011]

Flange dimensions, see page 9/57

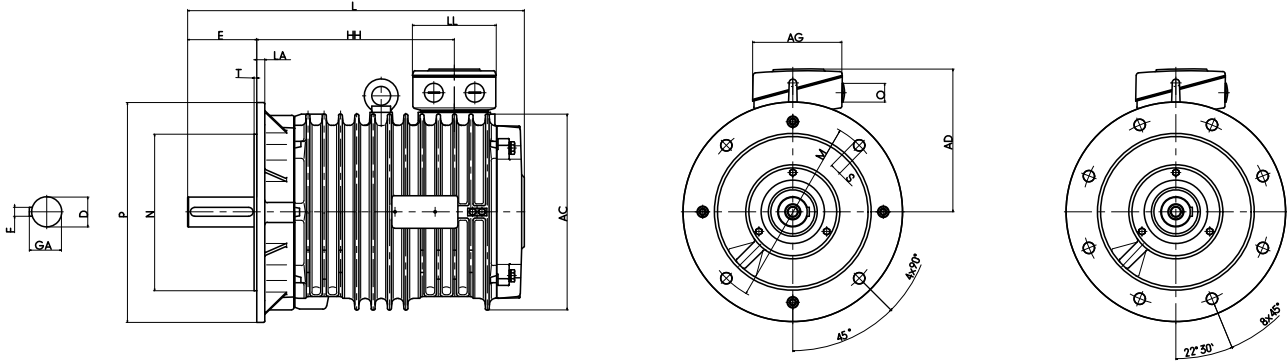

Type designation	-	AC	D	DA	DB ¹⁾	E	EA	F	FA	GA	GC	H	HA	L	LC	LD	TB	Type	AG	LL	O	Hole pattern
	B5	g	d	d1	-	l	l1	u	u1	t	t1	h	c	k	k1	A						
ARC 112 M	A300	217	32	32	M12	80	80	10	10	35	35	112	18	450	540	-	25 A	143	134	M32 x 1.5	4L	
ARC 132 S	A350	258	38	38	M12	80	80	10	10	41	41	132	20	515	605	-	25 A	143	134	M32 x 1.5	4L	
ARC 132 M	A350	258	38	38	M12	80	80	10	10	41	41	132	20	515	605	-	25 A	143	134	M32 x 1.5	4L	
ARC 160 S	A350	313	48	42	M16	110	110	14	12	51.5	45	160	25	540	658	-	25 A	143	134	M32 x 1.5	4L	
ARC 160 M	A350	313	48	42	M16	110	110	14	12	51.5	45	160	25	540	658	-	25 A	143	134	M32 x 1.5	4L	
ARC 160 MX	A350	313	48	42	M16	110	110	14	12	51.5	45	160	25	592	710	-	25 A	143	134	M32 x 1.5	4L	
ARC 160 L	A350	313	48	42	M16	110	110	14	12	51.5	45	160	25	592	710	-	25 A	143	134	M32 x 1.5	4L	
ARC 180 S	A400	351	55	48	M20	110	110	16	14	59	51.5	180	25	610	730	-	63 A	175	162	M40 x 1.5	4L	
ARC 180 M	A400	351	55	48	M20	110	110	16	14	59	51.5	180	25	610	730	-	63 A	175	162	M40 x 1.5	4L	
ARC 180 L	A400	351	55	48	M20	110	110	16	14	59	51.5	180	25	694	814	-	63 A	175	162	M40 x 1.5	4L	
ARC 200 M	A450	390	60	55	M20	140	110	18	16	64	59	200	27	845	965	-	100 A	213	207	M50 x 1.5	8L	
ARC 200 L	A450	390	60	55	M20	140	110	18	16	64	59	200	27	845	965	-	100 A	213	207	M50 x 1.5	8L	
ARC 225 M	A550	440	65	55	M20	140	110	18	16	69	59	225	30	815	935	-	100 A	213	207	M50 x 1.5	8L	
ARC 250 S	A550	490	75	65	M20	140	140	20	18	79.5	69	250	33	840	990	-	200 A	282	242	M63 x 1.5	8L	
ARC 250 M	A550	490	75	65	M20	140	140	20	18	79.5	69	250	33	840	990	-	200 A	282	242	M63 x 1.5	8L	
ARC 280 S	A660	550	80	70	M20	170	140	22	20	85	74.5	280	40	970	1120	-	200 A	282	242	M63 x 1.5	8L	
ARC 280 M	A660	550	80	70	M20	170	140	22	20	85	74.5	280	40	970	1120	-	200 A	282	242	M63 x 1.5	8L	
ARC 315 M	A660	616	90	75	M24	170	140	25	20	95	79.5	315	44	1275	1415	-	200 A	282	242	M63 x 1.5	8L	
ARC 315 L	A660	616	90	75	M24	170	140	25	20	95	79.5	315	44	1275	1415	-	200 A	282	242	M63 x 1.5	8L	
ARC 355 MY	A800	715	100	80	M24	210	170	28	22	106	85	355	50	1400	1580	-	400 A	311	294	M63 x 1.5	8L	
ARC 355 M	A800	715	100	80	M24	210	170	28	22	106	85	355	50	1400	1580	-	400 A	311	294	M63 x 1.5	8L	
ARC 355 MX	A800	715	100	80	M24	210	170	28	22	106	85	355	50	1400	1580	-	400 A	311	294	M63 x 1.5	8L	
ARC 355 L	A800	715	100	80	M24	210	170	28	22	106	85	355	50	1400	1580	-	400 A	311	294	M63 x 1.5	8L	
ARC 400 L	A1000	800	110	90	M24	210	170	28	25	116	95	400	55	1630	1820	-	400 B	415	340	M63 x 1.5	8L	

Overview of technical data

Three-phase roller table motors with squirrel-cage rotor, heavy-duty version for mains operation, non-ventilated, type of cooling IC 410

The most important technical data are summarised in the following table. Further information can be taken from the catalogue section "Introduction" (chapter 1).

Product group	Squirrel-cage rotor, IEC/EN
Rated output	ARB... 0.4 kW to 5.5 kW
Sizes	ARB...22 (132), 33 (125), 54 (170) and 65 (200)
Housing material	Grey cast iron
Rated torque	8 Nm to 77 Nm
Duty types	S4/S5 to IEC/EN 60034-1
Method of connection	Single-speed motors are designed in star-delta configuration as standard.
Stator winding insulation	Thermal class 155, optionally 155 [F(B)], 180 to IEC/EN 60034-1
Degree of protection	IP 55 to IEC/EN 60034-5, optionally IP 56 and higher
Type of cooling	IC 410 (non-ventilated) to IEC/EN 60034-6
Coolant temperature/ installation altitude	Standard -20 °C to +40 °C, Altitude 1000 m above sea level
Rated voltage	Standard voltages to EN 60038 50 Hz: 230 V, 400 V, 500 V, 690 V 60 Hz: 275 V, 460 V, 480 V, 600 V Rated Voltage ranges A to IEC/EN
Types of construction	IM B3, IM B35, IM B5 and derived types to IEC/EN 60034-7
Paint finish	Normal finish "Moderate", colour RAL 7031, blue-grey Special finish "Worldwide", colour RAL 7031, blue-grey
Vibration severity grade	Grade "A" as standard for machines with no special vibration requirements
Shaft ends	to DIN 748 (IEC 60072), balanced with half-key
Limit speeds	Please refer to the section of "Limit speeds" in catalogue section "Motors for converter-fed operation", Chapter 4.
Bearing design	Please refer to the section "Bearings".
Motor mass	Please refer to the technical selection lists.
Terminal boxes	Please refer to the section "Terminal boxes".
Documentation	An operating and maintenance manual, a terminal plan and a safety data sheet are supplied with each motor.
Tolerances	Please refer to the section "Tolerances" in catalogue section "Introduction", Chapter 1.
Options	Please refer to the section "Overview of modifications" in catalogue section "Introduction", Chapter 1.

Motor selection data

Three-phase roller table motors with squirrel-cage rotor for direct on-line starting, series ARB

Non-ventilated with surface cooling, type of cooling IC 410, duty type S1, continuous duty, thermal class H, degree of protection IP 44/IP 54, 50 Hz

Type	P	M _n	n	I _a at 400 V	B		Ma	t _k	J	m
	kW	Nm	rpm	A	IP 44 kgm ² /h	IP 54 kgm ² /h	Nm	min	kgm ²	kg
Synchronous speed 1500 rpm – 4-pole version										
ARB 22/4	1.1	8	1330	12	200	150	22.5	7.0	0.0140	60
ARB 33/4	2.2	15	1430	37	260	200	56.0	4.0	0.0430	90
Synchronous speed 1000 rpm – 6-pole version										
ARB 22/6	0.8	9	850	7	330	250	18.5	13.0	0.0140	60
ARB 33/6	1.5	15	940	21	570	440	53.0	10.0	0.0430	90
ARB 54/6	5.5	56	930	76	1400	1000	240.0	5.5	0.2330	200
Synchronous speed 750 rpm – 8-pole version										
ARB 22/8	0.6	9	650	7	480	370	22.5	20.0	0.0140	60
ARB 33/8	1.1	15	690	13	740	580	42.0	14.0	0.0430	90
ARB 54/8	4.0	56	680	49	1700	1300	190.0	5.5		
ARB 65/8	5.5	75	700	67	2450	1900	210	10.0	0.5750	290
Synchronous speed 600 rpm – 10-pole version										
ARB 33/10	0.8	14	530	8	1100	860	28.0	40.0	0.0430	90
ARB 54/10	3.0	52	555	36	2600	2000	170.0	18.0	0.2330	200
ARB 65/10	4.0	68	560	58	3600	2800	250	7.5	0.5750	290
Synchronous speed 500 rpm – 12-pole version										
ARB 33/12	0.4	8	460	7	1600	1200	29.0	55.0	0.0430	90
ARB 54/12	2.2	47	450	24	4000	3100	140.0	27.0	0.2330	200
ARB 65/12	3.0	63	455	32	5100	4000	200	20.0	0.5750	290
Synchronous speed 375 rpm – 16-pole version										
ARB 54/16	1.1	31	340	18	5100	4000	115.0	30.0	0.2330	200
ARB 65/16	2.2	60	350	33	8500	6600	200	28.5	0.5750	290
Synchronous speed 250 rpm – 24-pole version										
ARB 54/24	0.8	40	190	12	7000	5400	100.0	80.0	0.2330	200
ARB 65/24	1.5	68	210	25	13500	10600	175	50.0	0.5750	290
Synchronous speed 500/1000 rpm – 12/6-pole version										
ARB 54/12	2.5	54	440	26	3000	2300	135	10.0	0.2330	200
-6	4.0	42	920	43	750	600	100	2.2		
ARB 65/12	3.7	77	460	43	5200	4000	210	12.0	0.5750	290
-6	5.0	50	950	41	1500	1100	170	3.5		

t_k... max. permissible blocking period

B... Acceleration factor

B = J_G × z × k [kgm²/h]

J_G... Total moment of inertia in kgm² for motor + roller + load. referred to the motor shaft

z... Switching frequency in starts per hour

k... Factor to account for switched operation. k = 1 for simple starting. k = 4 for reversing

Dimensions

Three-phase roller table motors with squirrel-cage rotor

Series ARB

with surface cooling, type of cooling IC 410, degree of protection IP 55

Type of construction IM B3 [IM 1001]

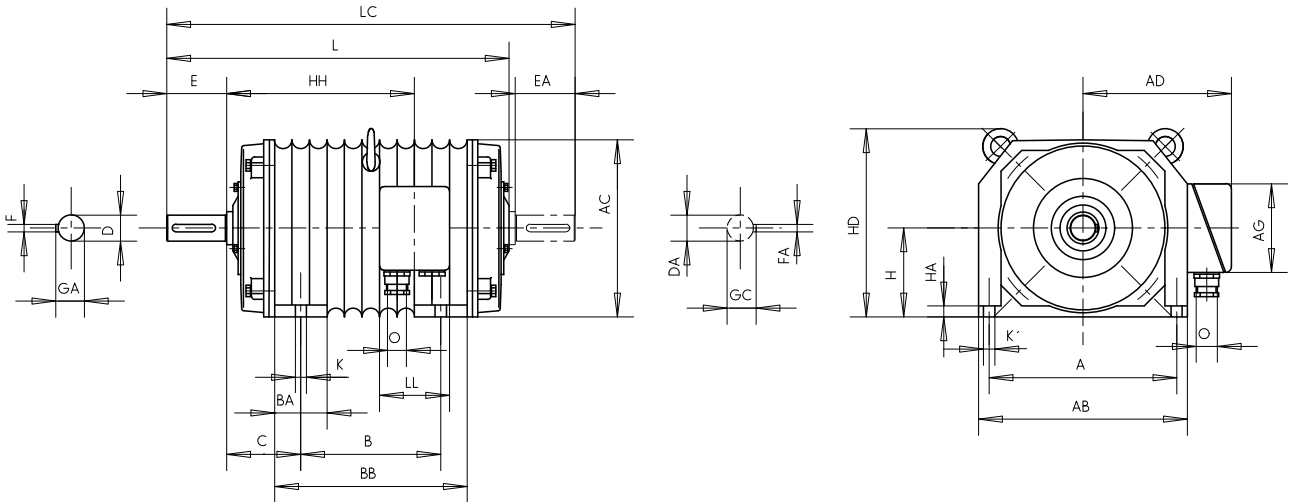

Type of construction IM B35 [IM 2001]

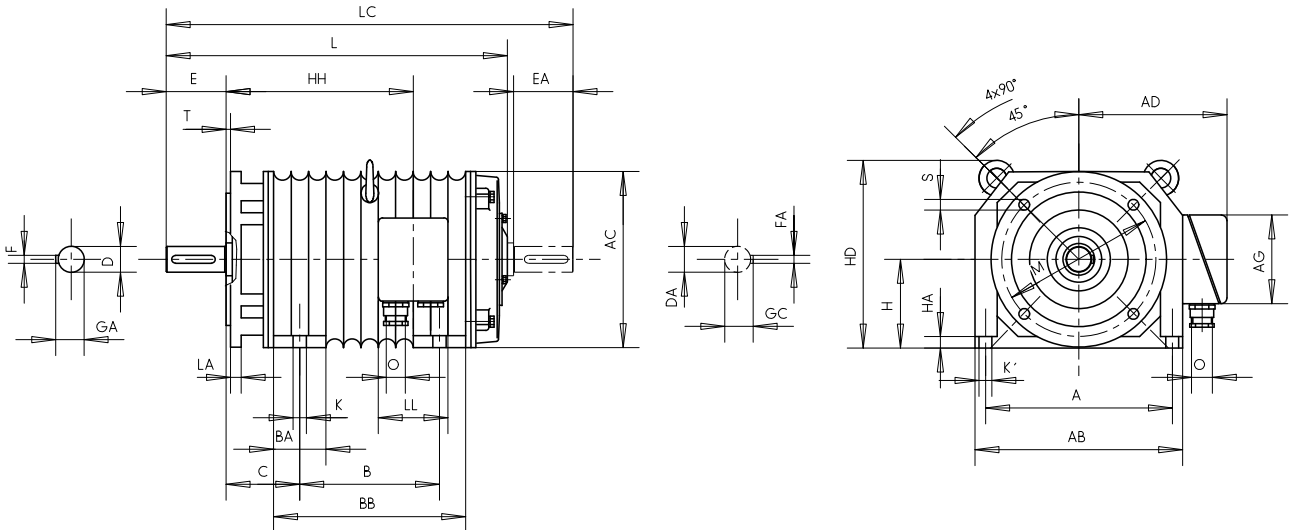

Type designation	-	A	AB	AC	AD	B	BA	BA1	BB	C	CA	D	DA	DB ¹⁾	E	EA	F	FA
	B5	b	f	g	g1	a	m	m1	e	w1	w2	d	d1	-	l	l1	u	u1
ARB 22	A195	216	268	194	180	178	64	-	242	130	130	24	24	M12	50	50	8	8
ARB 33	A250a	230	280	236	210	250	85	-	335	123	123	28	28	M12	60	60	8	8
ARB 54	A300a	320	390	330	245	270	90	-	360	164	164	38	38	M12	80	80	10	10
ARB 65	A350a	370	450	380	280	315	77	-	392	187.5	188	48	48	M16	110	110	14	14

¹⁾ Centre holes to DIN 332-DS

Type designation	GA	GC	H	HA	HD	K	K'	L	LC	HH	TB Type	AG	LL	O	Hole pattern
	t	t1	h	c	p	s	s'	k	k1	A					
ARB 22	27	27	132	20	245	13	13	487	538	294	ARB	130	130	M32 x 1.5	4L
ARB 33	31	31	125	25	266	15	15	552	616	347	ARB	130	130	M32 x 1.5	4L
ARB 54	41	41	170	32	361	22	22	660	758	421	ARB	130	130	M32 x 1.5	4L
ARB 65	52	52	200	32	400	22	22	770	910	485	ARB	130	130	M32 x 1.5	4L

Three-phase roller table motors with squirrel-cage rotor

Series ARB

with surface cooling, type of cooling IC 410, degree of protection IP 55

Type of construction IM B5 [IM 3001] to size 280

Type of construction IM V1 [IM 3011]

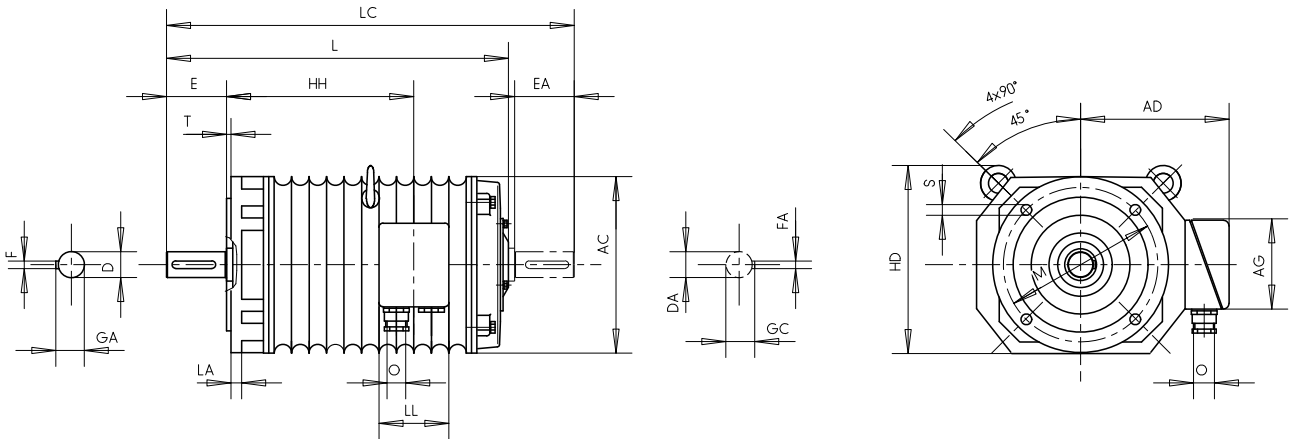

Type designation	-	AC	AD	D	DA	DB ¹⁾	E	EA	F	FA	GA	GC	H	HA	L	LC	LD	TB Type	AG	LL	O	Hole pattern
	B5	g	g1	d	d1	-	l	l1	u	u1	t	t1	h	c	k	k1	A					
ARB 22	A195	194	180	24	24	M12	50	50	8	8	27	27	132	20	487	538	294	ARB	130	130	M32 x 1.5	4L
ARB 33	A250a	236	210	28	28	M12	60	60	8	8	31	31	125	25	552	616	347	ARB	130	130	M32 x 1.5	4L
ARB 54	A300a	330	245	38	38	M12	80	80	10	10	41	41	170	32	660	758	421	ARB	130	130	M32 x 1.5	4L
ARB 65	A350a	380	280	48	48	M16	110	110	14	14	52	52	200	32	770	910	485	ARB	130	130	M32 x 1.5	4L

Overview of technical data

Three-phase roller table motors with squirrel-cage rotor, welded steel, transnorm, type of cooling IC 410, 411, 416, 71W (31W)

The most important technical data are summarised in the following table. Further information can be taken from the catalogue section "Introduction" (chapter 1).

Product group	Roller table motors, squirrel-cage rotor, IEC
Series	DS..
Rated output	100 kW to 1500 kW
Sizes	355 to 630
Housing material	Sheet steel, with welded radial ribs or double jacket for type of cooling IC 31, IC 71
Rated torque	1000 Nm to 15000 Nm
Method of connection	Single-speed motors are designed in star-delta configuration as standard.
Stator winding insulation	Thermal class 155, optionally 155 [F(B)], 180 to IEC/EN 60034-1
Degree of protection	IP 55 to IEC/EN 60034-5, optionally IP 56 and higher
Type of cooling	IC 411 [self-ventilated], IC 416 [forced ventilation], IC 410 [non-ventilated] oder IC 31 [water-jacket cooling] to IEC/EN 60034-6
Coolant temperature/ installation altitude	Standard -20 °C to +40 °C, Altitude 1000 m above sea level
Rated voltage	Standard voltages to EN 60038 50 Hz: 230 V, 400 V, 500 V, 690 V 60 Hz: 275 V, 460 V, 480 V, 600 V Rated Voltage ranges A and B to IEC/EN 60034-1
Types of construction	IM B3, IM B35, IM B5 and derived types to IEC/EN 60034-7
Paint finish	Normal finish "Moderate", colour RAL 7031, blue-grey Special finish "Worldwide", colour RAL 7031, blue-grey
Vibration severity grade	Grade "A" as standard for machines with no special vibration requirements
Shaft ends	to DIN 748 (IEC 60072), balanced with half-key
Sound pressure level	to DIN EN ISO 1680, tolerance +3 dB, upon request
Limit speeds	upon request
Bearing design	upon request
Motor mass	upon request
Terminal boxes	upon request
Documentation	An operating and maintenance manual, a terminal plan and a safety data sheet are supplied with each motor.
Tolerances	Please refer to the section "Tolerances" in catalogue section "Introduction", Chapter 1.
Options	Please refer to the section "Overview of modifications" in catalogue section "Introduction", Chapter 1.

Motor selection data

Welded steel three-phase asynchronous motors for rolling mills Overview of sizes and outputs

Type of cooling IC 411 [self-ventilated], IC 416 [forced ventilation], IC 410 [non-ventilated] and IC 31 [water-jacket cooling]
duty type S1, thermal class 155 [F], degree of protection IP 55,
rated voltage 690 V, rated frequency 50 Hz

Type of cooling	IC 411		IC 416		IC 410		IC 31	
Size	P _B [kW]	Type	P _B [kW]	Type	P _B [kW]	Type	P _B [kW]	Type
Synchronous speed 1500 rpm – 4-pole version								
355 M	340	DS 355 M...-4	340	DSf 355 M...-4	155	DSo 355 M...-4	340	DSWM 355 M...-4
355 L	400	DS 355 L...-4	400	DSf 355 L...-4	190	DSo 355 L...-4	400	DSWM 355 L...-4
400 M	490	DS 400 M...-4	490	DSf 400 M...-4	220	DSo 400 M...-4	490	DSWM 400 M...-4
400 L	550	DS 400 L...-4	550	DSf 400 L...-4	265	DSo 400 L...-4	550	DSWM 400 L...-4
450 S	610	DS 450 S...-4	610	DSf 450 S...-4	275	DSo 450 S...-4	610	DSWM 450 S...-4
450 M	770	DS 450 M...-4	770	DSf 450 M...-4	325	DSo 450 M...-4	770	DSWM 450 L...-4
450 L	840	DS 450 L...-4	840	DSf 450 L...-4	360	DSo 450 L...-4	840	DSWM 450 L...-4
500 M	960	DS 500 M...-4	960	DSf 500 M...-4	385	DSo 500 M...-4	960	DSWM 500 M...-4
500 L	1200	DS 500 L...-4	1200	DSf 500 L...-4	480	DSo 500 L...-4	1200	DSWM 500 L...-4
Synchronous speed 1000 rpm – 6-pole version								
355 M	280	DS 355 M...-6	280	DSf 355 M...-6	130	DSo 355 M...-6	280	DSWM 355 M...-6
355 L	330	DS 355 L...-6	330	DSf 355 L...-6	160	DSo 355 L...-6	330	DSWM 355 L...-6
400 M	410	DS 400 M...-6	410	DSf 400 M...-6	180	DSo 400 M...-6	410	DSWM 400 M...-6
400 L	460	DS 400 L...-6	460	DSf 400 L...-6	220	DSo 400 L...-6	460	DSWM 400 L...-6
450 S	510	DS 450 S...-6	510	DSf 450 S...-6	230	DSo 450 S...-6	510	DSWM 450 S...-6
450 M	640	DS 450 M...-6	640	DSf 450 M...-6	270	DSo 450 M...-6	640	DSWM 450 L...-6
450 L	700	DS 450 L...-6	700	DSf 450 L...-6	300	DSo 450 L...-6	700	DSWM 450 L...-6
500 M	800	DS 500 M...-6	800	DSf 500 M...-6	320	DSo 500 M...-6	800	DSWM 500 M...-6
500 L	1000	DS 500 L...-6	1000	DSf 500 L...-6	400	DSo 500 L...-6	1000	DSWM 500 L...-6
560 L	1120	DS 560 L...-6	1120	DSf 560 L...-6			1350	DSWM 560 L...-6
630 L							1500	DSWM 630 L...-6
Synchronous speed 750 rpm – 8-pole version								
355 M	210	DS 355 M...-8	210	DSf 355 M...-8	100	DSo 355 M...-8	210	DSWM 355 M...-8
355 L	250	DS 355 L...-8	250	DSf 355 L...-8	120	DSo 355 L...-8	250	DSWM 355 L...-8
400 M	310	DS 400 M...-8	310	DSf 400 M...-8	135	DSo 400 M...-8	310	DSWM 400 M...-8
400 L	350	DS 400 L...-8	350	DSf 400 L...-8	165	DSo 400 L...-8	350	DSWM 400 L...-8
450 S	380	DS 450 S...-8	380	DSf 450 S...-8	175	DSo 450 S...-8	380	DSWM 450 S...-8
450 M	480	DS 450 M...-8	480	DSf 450 M...-8	205	DSo 450 M...-8	480	DSWM 450 L...-8
450 L	530	DS 450 L...-8	530	DSf 450 L...-8	225	DSo 450 L...-8	530	DSWM 450 L...-8
500 M	600	DS 500 M...-8	600	DSf 500 M...-8	240	DSo 500 M...-8	600	DSWM 500 M...-8
500 L	750	DS 500 L...-8	750	DSf 500 L...-8	300	DSo 500 L...-8	750	DSWM 500 L...-8
560 L	840	DS 560 L...-8	840	DSf 560 L...-8			1010	DSWM 560 L...-8
630 L							1120	DSWM 630 L...-8



Explosion-protected motors

Contents

Product description _____	10/2
Increased safety „e“ („eb“)	
Overview of technical data _____	10/7
Motor selection data _____	10/8
IE3-K..R for Premium Efficiency IE3	
IE2-K..R for High Efficiency IE2	
K..R without efficiency classification	
K11R for converter-fed operation	
Bearings _____	10/45
Terminal boxes _____	10/55
Dimensions _____	10/58

Flameproof enclosure “d/de” (“db/db eb”)

Overview of technical data _____	10/124
Motor selection data _____	10/125
(IE3-)K8.R... (Y3) for Premium Efficiency IE3	
(IE2-)K8.R... (Y2) for High Efficiency IE2	
K8.R... for Standard Efficiency IE1	
B82R... with built-in brake	
B82R... with built-in brake, pole-changing	
K82R... with built-on brake	
Bearings _____	10/138
Terminal boxes _____	10/140
Dimensions _____	10/144

Type of explosion protection “n” (increased safety “ec”) / Protection by enclosure “tb”, “tc”

Overview of technical data _____	10/156
Motor selection data _____	10/157
IE3-W4.R for Premium Efficiency IE3	
IE2-WE..R for High Efficiency IE2	
(IE1-)K..R, K2.. for Standard Efficiency IE1	
Bearings	
Identical to bearings of standard motors, see Chapter 2	
Terminal boxes _____	10/195
Dimensions _____	10/198

Product description

Explosion-protected motors

In production areas and service rooms in which potentially explosive gas and vapour-air mixtures may arise or else the formation of combustible dusts is possible, all electrical equipment must be designed specifically for use in hazardous areas. Explosion-protected motors for protection type 'Increased safety "e" ("eb")' are a technically and economically optimum solution for use in explosive atmospheres of Zone 1, Equipment Group II, Category 2. The motor series K..R ... Ex e can also be supplied with efficiency classifications IE1 to IE3. Motors for use in Zone 2, Zone 21 and Zone 22 are supplied both in standard versions (series K...) and with enhanced efficiency (series W...), including IE classification.

Directive 2014/34/EU (ATEX) (old: Directive 94/9/EC)

Since 26th February 2014, equipment and protective systems intended for use in potentially explosive atmospheres must comply with Directive 2014/34/EU, which thus supersedes Directive 94/9/EU.

The fundamental health- and safety-related demands placed on equipment and protective systems intended for use in potentially explosive atmospheres have not changed with introduction of the new Directive 2014/34/EU. The *Notified Bodies* have applied the stipulations of the new directive since 20th April 2016. Certificates issued previously in accordance with Directive 94/9/EU nevertheless remain fully valid.

Products which were placed on the market before 20th April 2016 and thus possess an EC Declaration of Conformity in accordance with Directive 94/9/EC can also be sold with this EC Declaration of Conformity after the above date. Products which were placed on the market or taken into service for the first time after 20th April 2016, however, require an EU Decla-

Motors of the VEM type series have been tested and certified by Physikalisch-Technische Bundesanstalt Braunschweig (*Notified Body no. 102*), IBExU Freiberg (*Notified Body no. 0637*) and Dekra Exam Bochum (*Notified Body no. 0158*). All member states of the European Union recognise these test certificates.

The aforementioned test certificates are similarly accepted as approval by CENELEC members outside the EU. Where a special design influences explosion protection (different frequency, output, coolant temperature, etc.), additional or renewed certification may be necessary.

ration of Conformity in accordance with Directive 2014/34/EU. All VEM series have been tested regarding compliance with the new ATEX Directive and additional risk assessments have been conducted for the individual products. Corresponding EU Declarations of Conformity can be supplied.

Physikalisch-Technische Bundesanstalt Braunschweig and IBExU Freiberg, as *Notified Bodies* in accordance with Article 9 of the Directive of the Council of the European Community of 23rd March 1994 (94/9/EC), have confirmed that VEM motors comply with the fundamental health- and safety-related demands applicable to the design and manufacture of equipment and protective systems intended for use in potentially explosive atmospheres in accordance with Annex II of the directive. The quality assurance system is certified to ISO 9001:2008 by DNV GL Business Assurance, Essen and by IBExU Institut für Sicherheitstechnik GmbH, *Notified Body no. 0637*, and is monitored in accordance with Article 10(1) of Directive 2014/34/EU.

DNV-GL

MANAGEMENT SYSTEM CERTIFICATE

Certificate No: 156816-2014-AQ-GER-DAKKS Initial certification date: 19. March 1999 Valid: 08. June 2014 - 06. June 2017

This is to certify that the management system of

VEM motors GmbH
Carl-Friedrich-Gauß-Straße 1, 38855 Wernigerode, Germany
and the sites as mentioned in the appendix accompanying this certificate

has been found to conform to the Quality Management System standard:

ISO 9001:2008

This certificate is valid for the following scope:
Development, production and sale of electric motors, generators and drive systems for common appliance and apparatus for potentially explosive areas

Place and date:
Essen, 09. June 2015

For the issuing office:
DNV GL - Business Assurance
Schmieringhof 14, 45329 Essen, Germany

DAKKS
Deutsche
Akreditierungsstelle
D-ZM 18453-01-00
Thomas Beck
Management Representative

Lack of fulfillment of conditions as set out in the Certification Agreement may render this Certificate invalid.
AQ-2010-101-0101 DNV GL Business Assurance Zertifizierung und Umweltgütekriter GmbH, Schmieringhof 14, 45329 Essen, Germany.
TEL: +49 201 7296-222 www.dnvgl.de/assurance

DNV-GL

Certificate No: 156816-2014-AQ-GER-DAKKS
Place and date: Essen, 09. June 2015

Appendix to Certificate

VEM motors GmbH
Locations included in the certification are as follows:

Site Name	Site Address	Site Scope
VEM motors GmbH	Carl-Friedrich-Gauß-Str. 1, 38855 Wernigerode, Germany	Development, production and sale of electric motors, generators and drive systems for common appliance and apparatus for potentially explosive areas
VEM motors Thurm GmbH	Außere Dresdner Straße 35, 08066 Zwickau, Germany	Development, production and sale of electric motors, generators and drive systems for common appliance and apparatus for potentially explosive areas
VEM Slovakia s.r.o.	Vrbovská cesta 102, SK-921 01, Piestany, Slovakia (Slovak Republic)	Production of units/modules for electric motors, generators and drive systems for common appliance and products for use in potentially explosive areas.
VEM Competence Center Berlin	Marzahner Straße 34, 13053 Berlin, Germany	Sale of electric motors, generators and drive systems for common appliance and apparatus for potentially explosive areas.
VEM Competence Center Disseldorf	Gothaer Straße 4, 40880 Ratingen, Germany	Sale of electric motors, generators and drive systems for common appliance and apparatus for potentially explosive areas.
VEM Competence Center Leipzig	Bitterfelder Straße 1, 04129 Leipzig, Germany	Sale of electric motors, generators and drive systems for common appliance and apparatus for potentially explosive areas.
VEM Competence Center München	Max-Planck-Straße 17 85716 Unterschleißheim, Germany	Sale of electric motors, generators and drive systems for common appliance and apparatus for potentially explosive areas.

Lack of fulfillment of conditions as set out in the Certification Agreement may render this Certificate invalid.
AQ-2010-101-0101 DNV GL Business Assurance Zertifizierung und Umweltgütekriter GmbH, Schmieringhof 14, 45329 Essen, Germany.
TEL: +49 201 7296-222 www.dnvgl.de/assurance

Page 2 of 2

IBExU Institut für Sicherheitstechnik GmbH
An-Institut der TU Bergakademie Freiberg

[1] PRODUCT QUALITY ASSURANCE NOTIFICATION
according to Directive 94/9/EC, Annex VII

- Translation -

[2] Equipment or Protective Systems Intended for use in Potentially explosive atmospheres, Directive 94/9/EC

[3] Notification Number: **IBExU14ATEX Q014**

[4] Product Category: **Explosion-protected three-phase asynchronous motors**
Electrical equipment of the equipment group II, Categories 2 G and 2 D

[5] Manufacturer: **VEM motors GmbH**

[6] Address: **Carl-Friedrich-Gauß-Straße 1**
39555 Wernigerode
Germany

[7] Production site: **see [5]**

[8] IBExU Institut für Sicherheitstechnik GmbH, NOTIFIED BODY number 0637 in accordance with Article 9 of the Council Directive 94/9/EC of 23 March 1994, notifies to the manufacturer that he applies in the production site according to [7] a quality assurance system for the final inspection and testing of equipment of the product category mentioned in [4] which complies with Annex VII of the Directive.

[9] This notification is based on audit report no. IB-14-0-027 issued the 25 July 2014. It is valid until 10 July 2017. This notification can be withdrawn if the manufacturer no longer satisfies the requirements of Annex VII. Results of surveillance audit of the quality assurance system are a part of this notification.

[10] According to Article 10 (1) of the Directive 94/9/EC the CE marking shall be followed by the identification Number 0637 identifying the notified body involved in the production control stage.

IBExU Institut für Sicherheitstechnik GmbH
Fuchschlänweg 7 09590 Freiberg, Germany
t +49 (0) 3731 3805 0 f +49 (0) 3731 23650

Authorized for certifications
- Explosion protection -

Freiberg, 30 July 2014

By order

Certificates without signature and seal are not valid. Certificates may only be duplicated completely and unchanged. In case of doubts, the German text prevails.

Page 1 of 1
IBExU14ATEX Q014

IBExU Institut für Sicherheitstechnik GmbH
An-Institut der TU Bergakademie Freiberg

[1] PRODUCT QUALITY ASSURANCE NOTIFICATION
according to Directive 94/9/EC, Annex VII

- Translation -

[2] Equipment or Protective Systems Intended for use in Potentially explosive atmospheres, Directive 94/9/EC

[3] Notification Number: **IBExU14ATEX Q015**

[4] Product Category: **Explosion-protected three-phase asynchronous motors**
Electrical equipment of the equipment group II, Categories 2 G and 2 D

[5] Manufacturer: **VEM motors Thiem GmbH**

[6] Address: **Außere Dresdener Straße 35**
09590 Zwickau
Germany

[7] Production site: **see [5]**

[8] IBExU Institut für Sicherheitstechnik GmbH, NOTIFIED BODY number 0637 in accordance with Article 9 of the Council Directive 94/9/EC of 23 March 1994, notifies to the manufacturer that he applies in the production site according to [7] a quality assurance system for the final inspection and testing of equipment of the product category mentioned in [4] which complies with Annex VII of the Directive.

[9] This notification is based on audit report no. IB-14-0-027 issued the 25 July 2014. It is valid until 10 July 2017. This notification can be withdrawn if the manufacturer no longer satisfies the requirements of Annex VII. Results of surveillance audit of the quality assurance system are a part of this notification.

[10] According to Article 10 (1) of the Directive 94/9/EC the CE marking shall be followed by the identification Number 0637 identifying the notified body involved in the production control stage.

IBExU Institut für Sicherheitstechnik GmbH
Fuchschlänweg 7 09590 Freiberg, Germany
t +49 (0) 3731 3805 0 f +49 (0) 3731 23650

Authorized for certifications
- Explosion protection -

Freiberg, 30 July 2014

By order

Certificates without signature and seal are not valid. Certificates may only be duplicated completely and unchanged. In case of doubts, the German text prevails.

Page 1 of 1
IBExU14ATEX Q015

EU Declaration of Conformity
(according to Annex VII of EC Directive 2014/34/EU)

Manufacturer: **VEM motors GmbH** VEM motors Thiem GmbH
Address: **Carl-Friedrich-Gauß-Str. 1** Außere Dresdener Straße 35
D-39555 Wernigerode D-09590 Zwickau

Product description: **Explosion-protected three-phase asynchronous motors with squirrel-cage rotor of the series (IE)-JK... / (IE)-JKL... (Y2, Y3) / (IE)-JW... / (IE)-JB...**
Motors in energy efficient design according to IECEN 60034-30-1 receive the marking "IE" before the type designation, whereas * +1,2,3,4 according to the energy class of the motors.

The object of the declaration described above is in conformity with the relevant Union harmonization legislation:

2014/34/EU Directive of the European Parliament and of the Council of 26 February 2014 on the harmonization of the laws of the Member States relating to equipment and protective systems intended for use in potentially explosive atmospheres (recast), Official Journal of the European Union L96/299-306 of 29.03.2014

2006/42/EG Directive of the European Parliament and of the Council of 17. May 2006 on machinery, and amending Directive 90/269/EEC (recast), Official Journal of the European Union L157/24-46 vom 08.06.2006

This declaration of conformity is issued under the sole responsibility of the manufacturer. We confirm conformity of the product indicated above with the standards:

Reference number and date of issue: **EN 60079-0:2013+A11:2013** EN 60079-1:2014
EN 60079-7:2016 EN 60079-31:2014
EN 60034 with all relevant parts and supplements

The motors for which an EC type examination certificate from a notified body or a type examination certificate of an independent test laboratory is available, but it is related to some older standard editions, than these motors also fulfil the basic requirements for security and health protection from directive 2014/34/EU (ATEX)

The designated product is intended for incorporation into a machinery, and it must not be put into operation until the relevant machinery into which the product has been incorporated has been declared being in conformity with the provisions of Directive 2006/42/EC

The Quality Management System has been certified by IBExU Institut für Sicherheitstechnik GmbH with the Approval No. IBExU14ATEXQ014 and IBExU14ATEXQ015.

Wernigerode, 2015-10-27 Zwickau, 2016-10-27

Managing director Managing director

This declaration confirms compliance with the above-mentioned directives but is not a guarantee of product liability.

VEM Holding GmbH – Pörsch Lanchstraße 176 – D-01267 Dresden
Telefon +49 351 206-0 Fax +49 351 206-1028

Series (IE)-JK... / (IE)-JKL... (Y2, Y3) / (IE)-JW... / (IE)-JB...

Motor type IEC-size	EU	IEC	Group category (I, II) or (Dust)	Type of protection, temperature class, equipment protection level (EPL)
IEC-JK... 55 up to 400 IEC-JKL... 43 up to 400 IEC-JW... 43 up to 400 IEC-JB... 43 up to 400	CE	0037	II 2G	Ex db IIC T3... T6 or Ex db IIC T3... T6 Gb or Ex db IIC T3... T6 or Ex db IIC T3... T6 Gb
	CE	0037	II 2G	Ex db IIC T3... T6 or Ex db IIC T3... T6 Gb or Ex db IIC T3... T6 or Ex db IIC T3... T6 Gb
	CE	0037	II 2G	Ex db IIB+H2 T3... T6 or Ex db IIB+H2 T3... T6 Gb or Ex db IIB+H2 T3... T6 or Ex db IIB+H2 T3... T6 Gb
	CE	0037	II 2G	Ex db IIB+H2 T3... T6 or Ex db IIB+H2 T3... T6 Gb or Ex db IIB+H2 T3... T6 or Ex db IIB+H2 T3... T6 Gb
	CE	0037	II 2G	Ex db IIC T2, T3 or T4 Gc (Ex nA IIC T3, T3 or T4 Gc)
	CE	0037	II 2G	Ex db IIC T1/T2, T3 or T4 Gb (Ex nC I1/T2, T3 or T4 Gb)
	CE	0037	II 2G	Ex to IIB Txx°C Dc or Ex to IIC Txx°C Dc
	CE	0037	II 2G	Ex to IIC Txx°C Dc
	CE	0037	II 2G	Ex db IIC T3... T6 or Ex db IIC T3... T6 Gb or Ex db IIC T3... T6 or Ex db IIC T3... T6 Gb or optionally Ex db IIC T250 °C... T80 °C Dc
	CE	0037	II 2G	Ex db IIC T3... T6 or Ex db IIC T3... T6 Gb or optionally Ex to IIC T250 °C... T80 °C Dc
	CE	0037	II 2G	Ex db IIB+H2 T3... T6 or Ex db IIB+H2 T3... T6 Gb or Ex db IIB+H2 T3... T6 or Ex db IIB+H2 T3... T6 Gb or optionally Ex to IIC Txx°C Dc
	CE	0037	II 2G	Ex db IIB+H2 T3... T6 or Ex db IIB+H2 T3... T6 Gb or Ex db IIB+H2 T3... T6 or Ex db IIB+H2 T3... T6 Gb or optionally Ex to IIC Txx°C Dc
CE	0037	II 2G	Ex db IIC T1/T2, T3 or T4 Gb (Ex nC I1/T2, T3 or T4 Gb) or optionally Ex to IIB Txx°C Dc or Ex to IIC Txx°C Dc	
CE	0037	II 2G	Ex db IIC T1/T2, T3 or T4 Gb (Ex nC I1/T2, T3 or T4 Gb) or optionally Ex to IIB Txx°C Dc or Ex to IIC Txx°C Dc	
CE	0037	II 2G	Ex to IIC Txx°C Dc or optionally Ex to IIC Txx°C Dc	
CE	0037	II 2G	Ex to IIC Txx°C Dc or optionally Ex to IIC Txx°C Dc	
CE	0037	II 2G	Ex to IIC Txx°C Dc or optionally Ex to IIC Txx°C Dc	
CE	0037	II 2G	Ex to IIC Txx°C Dc or optionally Ex to IIC Txx°C Dc	
CE	0037	II 2G	Ex to IIC Txx°C Dc or optionally Ex to IIC Txx°C Dc	
CE	0037	II 2G	Ex to IIC Txx°C Dc or optionally Ex to IIC Txx°C Dc	

¹⁾ conductive dust

NB 0637 — IBExU Inst. für Sicherheitstechnik GmbH, Fuchschlänweg 7, 09590 Freiberg (Germany)

VEM Holding GmbH – Pörsch Lanchstraße 176 – D-01267 Dresden
Telefon +49 351 206-0 Fax +49 351 206-1028

10

Marking according to old and new explosion protection standards

Motors assigned to Category 3 bear only a CE marking on their rating plate.
 The specification of an NB (*Notified Body*) ID number for quality assurance to Directive 2014/34/EU (old: Directive 94/9 EC) is excluded for these motors.

Machine type IEC size	EU	NB	Group/category G (gas) or D (dust)	Explosion protection type, temperature class, equipment protection level (EPL)
--------------------------	----	----	--	---

¹⁾ conductive dust

[Where a maximum surface temperature is specified: Zone 2 (gas): Entire surface including rotor and windings; Zones 21, 22 (dust): External surface (housing, shaft)]

Notified Body
ID number 0637... IBExU Institut für Sicherheitstechnik GmbH, Freiberg

Detailed information on explosion protection can be found in our Ex manual “Latest news on explosion protection 2017”.

Explosion protection type – Increased safety “e” (new: “eb”)

Design regulations: EN 60079-0/EN 60079-7

Definition/protection principle:

Explosion protection type for which additional measures are taken in order to prevent the occurrence of impermissibly high temperatures and the formation of sparks or arcs in use according to specifications or in specified unusual conditions with an increased degree of certainty:

- Prevention of sparks and other ignition sources
- Housing at least IP 54, if bare live parts are present in the interior
- Housing at least IP 44, if all live parts in the interior are insulated
- Observance of creepage distances and clearances
- Particular attention paid to the insulating materials and seals
- Temperatures of the exterior and interior surfaces must remain below the ignition temperature both in normal operation and in the event of a fault (locking of the motor)
- Protective devices (temperature monitoring and/or overcurrent switch with I_A/I_N-t_E time characteristic) to be provided by the user
- Regarding operation on a frequency converter, see Chapter 4

Tests:

- Insulation test
- Temperature measurements in defined fault cases
- Additional tests for certain equipment (TMS full protection)

Fields of application:

Equipment for Zones 1 and 2, Categories 2G and 3G (Gb, Gc)

Explosion protection type – Flameproof enclosure “d” (“db”)

Design regulations: EN 60079-0/EN 60079-1

Definition/protection principle:

Explosion protection type where components capable of igniting an explosive atmosphere are arranged in an enclosure which withstands the pressure arising inside the enclosure from explosion of an explosive mixture and prevents propagation of the explosion to the explosive atmosphere surrounding the enclosure:

- Observance of the explosion group
- Pressure-resistant housing
- Observance of required gap widths and lengths
- Terminal box with protection type ‘Flameproof enclosure “d”’ or ‘Increased safety “e”’
- Temperature of the exterior surface must remain below the ignition temperature of the gases present in the surrounding atmosphere

- An explosion may occur inside the enclosure, but the enclosure must withstand the pressure of this explosion and no flames or potentially ignitable hot gases must escape to the outside atmosphere via cracks or gaps in the enclosure

Tests:

- Reference pressure, resistance to pressure
- Sparkover
- Tightness of sealed gaps

Fields of application:

Equipment for Zones 1 and 2, Categories 2G and 3G (Gb, Gc)

Explosion protection type “n”, non-sparking (new: Increased safety “ec”)

Design regulations: EN 60079-0/EN 60079-15 (neu EN 60079-7)

Definition/protection principle:

Explosion protection type which ensures that electrical equipment is unable to ignite a potentially explosive surrounding atmosphere in normal operation. The design guarantees that the risk of arcing or sparks which could constitute an ignition hazard during normal use is minimised:

- Prevention of sparks and other ignition sources
- Housing at least IP 54
- Observance of creepage distances and clearances
- Particular attention paid to the insulating materials and seals

Temperatures of the exterior and interior surfaces must remain below the ignition temperature in normal operation

Tests:

- Insulation test
- Temperature measurement
- Additional tests for certain equipment (converter-fed operation)

Fields of application:

Equipment for Zone 2, Category 3G (Gc)

Explosion protection type – Protection by enclosure “tx IIY Dx”

Design regulations: EN 60079-0/EN 60079-31

Protection principle:

Housings which constitute a hazard are themselves enclosed in a correspondingly non-vulnerable housing. The maximum surface temperature must be demonstrated in accordance with the applicable category.

Minimum degree of protection IP 5X/6X (EN 60529)

New: Pressure test before the dust test with an overpressure of

- 4 kPa for equipment for protection level „ta“
 - 2 kPa for equipment for protection level „tb“ or „tc“
- Limitation of the prospective short-circuit current to 10 kA for EPL Da

Temperature limitation dependent on EPL

Determination of surface temperature for EPL Da with a dust layer of at least 500 mm on all accessible surfaces.

Tests:

- IP protection type test
- Ageing resistance of the plastic materials used in the equipment
- Impact test
- Tightness
- Thermal test under overload or fault conditions

Group classification:

- IIIA, combustible lint
- IIIB, non-conductive dust
- IIIC, conductive dust

Protection against ingress of dust according to Tab. 1, EN 60079-31

Group	Protection level	Housing degree of protection
III A (lint, fibres)	ta	IP 6X
	tb	IP 5X
	tc	IP 5X
III B (non-conductive dust)	ta	IP 6X
	tb	IP 6X
	tc	IP 5X
III C (conductive dust)	ta	IP 6X
	tb	IP 6X
	tc	IP 6X

Flange dimensions

Flanges with threaded holes

Flange type to E DIN EN 50347	Flange type to DIN 42948	LA c ₁	M e ₁	N b ₁	P a ₁	S s ₁	T f ₁
FT 65	C 80	6.5	65	50	80	M5	2.5
FT 75	C 90	8	75	60	90	M5	2.5
FT 85	C 105	8.5	85	70	105	M6	2.5
FT 100	C 120	8	100	80	120	M6	3
FT 115	C 140	10	115	95	140	M8	3
FT 130	C 160	10	130	110	160	M8	3.5
FT 165	C 200	12	165	130	200	M10	3.5
FT 215	C 250	12	215	180	250	M12	4

Flanges with through-holes

Flange type to E DIN EN 50347	Flange type to DIN 42948	LA c ₁	M e ₁	N b ₁	P a ₁	S s ₁	T f ₁
FF 100	A 120	9	100	80	120	7	3
FF 115	A 140	9	115	95	140	9	3
FF 130	A 160	9	130	110	160	9	3.5
FF 165	A 200	10	165	130	200	11	3.5
FF 215	A 250	11	215	180	250	14	4
FF 265	A 300	12	265	230	300	14	4
FF 300	A 350	13	300	250	350	18	5
FF 350	A 400	15	350	300	400	18	5
FF 400	A 450	16	400	350	450	18	5
FF 500	A 550	18	500	450	550	18	5
FF 600	A 660	22	600	550	660	22	6
FF 740	A 800	25	740	680	800	22	6

According to DIN EN 50347, the different sizes of FF flanges possess through-holes, while FT flanges possess threaded holes. The flange designations A and C defined in DIN 42948 remain valid.

Flange assignments which deviate from the standard are specified in the flange assignment tables. For tolerances for the dimension N (b₁), refer to the corresponding dimension tables LA (c₁) depth of engagement

Overview of technical data

The most important technical data are summarised in the following table.
Further information can be taken from the catalogue section "Introduction" (Chapter 1).

Product group	Squirrel-cage rotor, IEC/DIN
Explosion protection type	Increased safety „e“ („eb“)
Rated output	Ex e (Ex eb)/(IE.) – KPR/KPER/K..R, 0.12 to 320 kW
Sizes	Ex e (Ex eb)/(IE.) – KPR/KPER/K..R, 56 to 400
Housing material	Grey cast iron
Rated torque	0.4 Nm to 4500 Nm
Efficiency classification/ efficiency determination	IEC/EN 60034-30-1 / IEC/EN 60034-2-1, ≤ 1 kW direct measurement, > 1 kW residual loss method
Method of connection	Single-speed motors are designed in star-delta configuration as standard.
Stator winding insulation	Thermal class 155, optional 155 [F(B)], 180 to IEC/EN 60034-1
Degree of protection	IP 55 to IEC/EN 60034-5, optionally IP 56 or higher
Type of cooling	IC 411, IC 416, to IEC/EN 60034-6
Coolant temperature/ installation altitude	Standard -20 °C to +40 °C, (max. +55 °C) Deviating coolant temperatures upon request Altitude 1000 m above sea level
Rated voltage	Standard voltages to EN 60038 50 Hz: 230 V, 400 V, 500 V, 690 V, 60 Hz: 275 V, 460 V, 480 V, 600 V
Duty types	Continuous duty S1 and converter-fed operation
Types of construction	IM B3, IM B35, IM B5 and derived types to IEC/EN 60034-7
Paint finish	Normal finish "Moderate", colour RAL 7031, blue-grey Special finish "Worldwide", colour RAL 7031, blue-grey
Vibration severity grade	Grade "A" as standard for machines with no special vibration requirements
Shaft ends	to DIN 748 (IEC 60072), balanced with half-key
Limit speeds	Please refer to the section of "Limit speeds" in catalogue section "Motors for converter-fed operation", Chapter 4.
Bearing design	Please refer to the tables of bearing design data.
Motor mass	Please refer to the technical selection lists.
Terminal boxes	Please refer to the section "Terminal boxes".
Documentation	An operating and maintenance manual, a terminal plan and a safety data sheet are supplied with each motor.
Tolerances	Please refer to the section "Tolerances" in catalogue section "Introduction", Chapter 1.
Options	Please refer to the section "Overview of modifications" in catalogue section "Introduction", Chapter 1.

Three-phase motors with squirrel-cage rotor, Premium Efficiency IE3 Type of explosion protection – Increased safety „e“ („eb“) for operation in Zone 1 according to EN 60079-7

II 2G Ex e IIC T1/T2, T3 Gb

for rated voltage, temperature classes T1, T2 and T3
with surface cooling, duty type S1, continuous duty
thermal class F, degree of protection IP 55, 50 Hz

Motor selection data															Design point 400 V, 50 Hz													
Type	Temperature class	Voltage tolerance	max. Coolant temperature °C	P _B kW	M _B Nm	n _B rpm	η _B (IEC/EN 60034-30-1)			cos φ _B	I _B A	I _A /I _B	M _A /M _B	M _S /M _B	M _K /M _B	t _E -time	ATEX no.	J	m									
															100%	75%	50%	-	-	-	-	-	-	-	s	s		
Synchronous speed 3000 rpm – 2-pole version															kgm ²		kg											
IE3-K11R 315 S2 Ex e IIC	T1-T3			68	218	2975	IE3-											1.44	820									
IE3-K11R 315 S2G Ex e IIC	T1-T3	±10 %		68	218	2978	IE3-94.7			94.6	93.9	0.89	123	7.7	1.3	2.2	1.2	20	8	IBExU99ATEX1137/95	1.44	850						
IE3-K11R 315 M2 Ex e IIC	T1-T3			80	257	2975	IE3-											1.76	980									
IE3-K11R 315 M2G Ex e IIC	T1-T3			80	257	2975	IE3-											1.76	980									
IE3-K11R 315 MY2 Ex e IIC	T1-T3			110	353	2980	IE3-95.2			95.2	94.8	0.93	180	6.9	1.0	2.4	0.7	35	11		2.82	1270						
IE3-K11R 315 MY2G Ex e IIC	T1-T3	±10 %		110	353	2980	IE3-95.2			94.8	94.0	0.93	190	6.4	1.0	2.4	0.7	30	11	IBExU99ATEX1137/92	2.82	1270						
IE3-K11R 315 L2 Ex e IIC	T1-T3			125	401	2980	IE3-											3.66	1450									
IE3-K11R 315 L2G Ex e IIC	T1-T3			125	401	2980	IE3-											3.66	1450									
IE3-K11R 315 LX2 Ex e IIC	T1-T3			150	480	2985	IE3-											4.43	1630									
IE3-K11R 315 LX2G Ex e IIC	T1-T3			150	480	2985	IE3-											4.43	1630									
IE3-K12R 355 M2 Ex e	T1-T3			170	545	2980	IE3-											4.2	2000									
IE3-K42R 355 MX2 Ex e	T1-T3			200	641	2980	IE3-											5.5	2200									
IE3-K42R 355 L2 Ex e	T1-T3			240	769	2980	IE3-											7.1	2445									
IE3-K42R 400 M2 Ex e	T1-T3			270	865	2980	IE3-											8.44	3060									
IE3-K42R 400 L2 Ex e	T1-T3			300	961	2980	IE3-											10.41	3400									

Optionally in dust-protected version, protection type: Protection by enclosure "tb" to EN 60079-31
for operation in Zone 21 (IBExU 02ATEX 1019 for series K1.R), degree of protection IP 65, double marking on rating plate.
Other voltages and frequencies upon request. Changes are possible for motors which are not yet certified.

**Three-phase motors with squirrel-cage rotor, Premium Efficiency IE3
Type of explosion protection – Increased safety „e“ („eb“)
for operation in Zone 1 according to EN 60079-7**

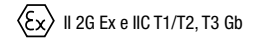

for rated voltage, temperature classes T1, T2 and T3
with surface cooling, duty type S1, continuous duty
thermal class F, degree of protection IP 55, 50 Hz

Motor selection data																	Design point 400 V, 50 Hz			
Type	Temperature class	Voltage tolerance	max. Coolant temperature °C	P _B kW	M _B Nm	n _B rpm	η _B (IEC/EN 60034-30-1)			cosφ _B	I _B 400 V	I _A /I _B	M _A /M _B	M _S /M _B	M _K /M _B	t _E -time T2 T3	ATEX no.	J kgm ²	m kg	
							100 %	75 %	50 %	-	A	-	-	-	s	s				
Synchronous speed 1500 rpm – 4-pole version																				
IE3-KPER 63 G4 Ex e IIC	T1-T3	±10 %	45	0.12	0.9	1355	IE3- 64.8	65.2	62.3	0.75	0.37	3.3	1.9	1.9	2.1	75	65	IBExU02ATEX1110/14	0.0002	5.2
IE3-KPR 63 G4 Ex e IIC	T1-T3	±5 %	55	0.18	1.2	1405	IE3- 69.9	68.0	62.2	0.7	0.55	4.1	2.1	2.1	2.6	70	60	IBExU02ATEX1110/29	0.0005	7.1
IE3-KPR 71 K4 Ex e IIC	***	***	***	0.25	***	***	***	***	***	***	***	***	***	***	***	***	***	***	***	***
IE3-KPR 71 G4 Ex e IIC	T1-T3	±10 %	60	0.37	2.5	1440	IE3- 77.3	77.6	75	0.69	1.02	5.8	2.9	2.9	3.3	45	40	IBExU02ATEX1111/39	0.0011	11.0
IE3-KPR 80 K4 Ex e IIC	***	***	***	0.55	***	***	***	***	***	***	***	***	***	***	***	***	***	***	***	***
IE3-KPR 80 GX4 Ex e IIC	T1-T3	±10 %	60	0.75	5.0	1445	IE3- 82.5	81.9	79	0.74	1.78	7.3	3.4	4.2	3.4	22	19	IBExU02ATEX1112/59	***	17.5
IE3-KPR 90 S4 Ex e IIC	T1-T3	±10 %	65	1.00	6.6	1450	IE3- 83.7	83.3	80.6	0.8	2.25	7.8	3.3	4.0	3.1	35	30	IBExU02ATEX1113/46	0.0045	28.0
IE3-KPR 90 LX4 Ex e IIC	T1-T3	±10 %	60	1.35	9.0	1435	IE3- 84.9	85.0	83.4	0.84	2.85	7.2	3.3	3.6	2.8	30	27	IBExU02ATEX1113/47	0.0058	31.0
IE3-KPR 100 L4 Ex e IIC	T1-T3	±10 %	65	2.00	13.2	1445	IE3- 86.3	86.7	85.4	0.81	4.25	7.5	3.3	3.8	3.0	30	26	IBExU02ATEX1114/45	0.011	45.0
IE3-KPR 100 LZ4 Ex e IIC	T1-T3	±10 %	65	2.50	16.5	1445	IE3- 87.1	87.6	86.4	0.83	5.2	7.6	2.9	3.7	2.7	28	24	IBExU02ATEX1114/44	0.013	50.0
IE3-KPR 112 M4 Ex e IIC	T1-T3	±10 %	55	3.6	24	1452	IE3- 88.7	89.9	90.0	0.89	6.9	7.2	1.9	3.1	1.6	17	15	***	0.02	65
IE3-K11R 112 M4 Ex e IIC	T1-T3	±10 %	55	3.6	24	1452	IE3- 88.7	89.9	90.0	0.89	6.9	7.2	1.9	3.1	1.6	17	15	PTB09ATEX3004/08	0.02	65
IE3-K11R 132 S4 Ex e IIC	T1-T3	±10 %	55	5.0	33	1465	IE3- 90.4	91.1	90.6	0.86	9.7	6.8	1.9	2.9	1.6	30	28	IBExU99ATEX1142/84	0.035	90
IE3-K11R 132 M4 Ex e IIC	T1-T3	±10 %	55	6.8	45	1457	IE3- 90.2	90.8	90.7	0.86	13.4	7.1	2.0	3.1	1.5	20	18	IBExU99ATEX1142/80	0.035	88
IE3-K11R 160 M4 Ex e IIC	T1-T3	±10 %	55	10.0	65	1471	IE3- 91.2	91.2	90.4	0.85	19.6	7.2	2.3	3.0	2.1	26	9	IBExU99ATEX1105/102	0.078	125
IE3-K11R 160 L4 Ex e IIC	T1-T3	±10 %	55	13.5	88	1473	IE3- 92.0	92.1	91.5	0.87	26	7.8	2.6	3.1	2.1	18	7	PTB08ATEX3038/26	0.115	168
IE3-K11R 180 M4 Ex e IIC	T1-T3	±10 %	55	15.0	97	1478	IE3- 92.2	91.9	90.8	0.84	29.5	7.3	1.9	2.7	1.7	35	12	IBExU99ATEX1138/51	0.168	215
	T1,T2	±10 %	55	17	110	1473	IE3- 92.4	91.9	91.2	0.86	32.5	6.7	1.6	2.4	1.5	35		IBExU99ATEX1138/52		
IE3-K11R 180 L4 Ex e IIC	T1-T3	±10 %	50	17.50	113	1479	IE3- 92.6	92.5	91.4	0.86	33.5	8.0	2.0	2.9	1.7	30	12	IBExU99ATEX1138/55	0.168	240
	T1,T2	±10 %	45	20	129	1476	IE3- 92.8	92.5	91.8	0.86	38	7.0	1.7	2.5	1.5	30		IBExU99ATEX1138/56		
IE3-K11R 200 L4C Ex e IIC	T1-T3	±10 %	55	24.0	154	1485	IE3- 93.2	93.7	93.3	0.87	45	7.2	1.4	2.3	1.2	35	11	IBExU99ATEX1143/53	0.313	345
	T1,T2	±10 %	55	27	174	1481	IE3- 93.4	94.6	94.3	0.87	51	6.3	1.3	2.1	1.1	30		IBExU99ATEX1138/54		
IE3-K11R 225 S4 Ex e IIC	T1-T3	±10 %	50	30.00	193	1483	IE3- 93.8	94.2	93.9	0.85	58	7.8	2.2	2.4	1.7	26	10	IBExU99ATEX1144/37	0.525	445
	T1,T2	±10 %	50	33	213	1480	IE3- 93.7	93.8	93.9	0.85	64	7.0	2.0	2.2	1.6	24		IBExU99ATEX1144/38		
IE3-K11R 225 M4 Ex e IIC	T1-T3	±10 %	40	36.00	232	1481	IE3- 93.9	94.3	94.2	0.84	69	7.2	2.0	2.2	1.6	21	7	IBExU99ATEX1144/39	0.525	450
	T1,T2	±10 %	40	40	259	1477	IE3- 94.1	94.1	94.2	0.85	78	6.4	1.8	2.0	1.4	17		IBExU99ATEX1144/40		
IE3-K11R 250 M4 Ex e IIC	T1-T3	±10 %	45	44.0	283	1486	IE3- 94.2	94.0	93.4	0.85	84	7.5	1.9	2.2	1.5	28	9	IBExU99ATEX1131/35	0.95	545
	T1,T2	±10 %	45	50	322	1484	IE3- 94.4	94.1	93.7	0.85	96	6.5	1.7	1.9	1.3	24		IBExU99ATEX1131/37		
IE3-K11R 280 S4 Ex e IIC	T1-T3	±10 %	45	58.0	372	1488	IE3- 95.4	95.5	95.0	0.82	113	7.8	1.4	2.2	1.2	35	16	IBExU99ATEX1030/52	1.96	775
	T1,T2	±10 %	45	68	438	1484	IE3- 95.0	95.4	95.2	0.83	132	6.7	1.2	1.8	1.0	30		IBExU99ATEX1030/53		
IE3-K11R 280 M4 Ex e IIC	T1-T3	±10 %	55	70.0	449	1488	IE3- 95.0	95.1	94.6	0.83	135	8.0	1.6	2.3	1.4	23	8	IBExU99ATEX1030/54	2.27	855
	T1,T2	±10 %	50	80	514	1485	IE3- 95.1	95.0	94.9	0.83	154	7.0	1.4	2.0	1.2	20		IBExU99ATEX1030/55		
IE3-K11R 315 S4 Ex e IIC	T1-T3	±10 %	40	84	539	1489	IE3- 95.1	95.1	94.6	0.84	161	8.0	1.5	2.2	1.4	23	8	IBExU99ATEX1030/85	2.73	995
	T1,T2	±10 %	40	100	643	1485	IE3- 95.3	95.2	95.0	0.84	194	6.6	1.2	1.8	1.1	18		IBExU99ATEX1030/86		
IE3-K11R 315 M4 Ex e IIC	T1-T3	±10 %	50	100	641	1491	IE3- 95.3	95.2	94.5	0.85	186	7.7	1.3	2.4	1.0	26	7	IBExU99ATEX1137/90	4.02	1175
	T1-T3	±10 %	45	120	770	1489	IE3- 95.5	95.3	95.0	0.86	225	6.4	1.1	2.0	0.9	21		IBExU99ATEX1137/91		
IE3-K11R 315 MY4 Ex e IIC	T1-T3	±10 %	40	115	737	1490	IE3- 95.5	95.3	94.5	0.85	218	6.9	1.1	2.1	0.9	35	14	IBExU99ATEX1137/89	4.82	1200
	T1,T2		40	115	738	1489	IE3-													
IE3-K11R 315 L4 Ex e IIC	T1-T3		40	135	865	1491	IE3-													
	T1,T2		165	1065	1480	IE3-														
IE3-K11R 315 LX4 Ex e IIC	T1-T3		40	170	1090	1490	IE3-													
	T1,T2		200	1291	1480	IE3-														
IE3-K12R 355 M4 Ex e IIC	T1-T3		40	215	1375	1493	IE3- 96.0	95.8	95.1	0.84	390	7.9	1.4	2.6	1.2	21	7	IBExU01ATEX1009/18	7.9	2150
IE3-K42R 355 MX4 Ex e	T1-T3		40	240	1538	1490	IE3-													
	T1,T2		275	1774	1480	IE3-														
IE3-K42R 355 L4 Ex e	T1-T3		40	275	1758	1494	IE3-													
	T1,T2		315	2033	1480	IE3-														
IE3-K42R 400 M4 Ex e	T1-T3		40	300	1918	1494	IE3-													
IE3-K42R 400 L4 Ex e	T1-T3		40	320	2046	1494	IE3-													

Optionally in dust-protected version, protection type: Protection by enclosure "tb" to EN 60079-31
for operation in Zone 21 (IBExU 02ATEX 1019 for series K1.R), degree of protection IP 65, double marking on rating plate.
Other voltages and frequencies upon request. Changes are possible for motors which are not yet certified.
***) upon request



Three-phase motors with squirrel-cage rotor, Premium Efficiency IE3 Type of explosion protection – Increased safety „e“ („eb“) for operation in Zone 1 according to EN 60079-7

Ex II 2G Ex e IIC T1/T2, T3 Gb

for rated voltage, temperature classes T1, T2 and T3
with surface cooling, duty type S1, continuous duty
thermal class F, degree of protection IP 55, 50 Hz

Motor selection data																Design point 400 V, 50 Hz					
Type	Temperature class	Voltage tolerance	max. Coolant temperature °C	P _B kW	M _B Nm	n _B rpm	η _B (IEC/EN 60034-30-1)			cosφ _B	I _B 400 V A	I _k /I _B	M _k /M _B	M _s /M _B	M _r /M _B	t _E -time		ATEX no.	J kgm ²	m kg	
							100 %	75 %	50 %							T2	T3				
Synchronous speed 1000 rpm – 6-pole version																					
IE3-KPR 80 G6 Ex e IIC	T1-T3	±10 %	60	0.55	5.60	945	IE3-	77.2	77.5	75	0.48	1.53	4.2	2.2	2.4	2.2	84	73	IBExU02ATEX1112/53	0.00425	18
IE3-KPR 90 L6 Ex e IIC	T1-T3	±10 %	50	0.95	9.45	960	IE3-	80.2	78.6	74.7	0.67	2.65	5.6	3.1	3.5	2.8	46	41	IBExU02ATEX1113/42	0.00720	30.0
IE3-KPR 100 LX6 Ex e IIC	T1-T3	±10 %	50	1.30	12.9	960	IE3-	81.8	81.5	78.6	0.72	3.20	6.0	2.4	3.2	2.4	97	87	IBExU02ATEX1114/39	0.01390	36.0
IE3-KPER 112 MV6 Ex e IIC	T1-T3	±10 %	50	1.90	18.8	965	IE3-	83.6	82.6	78.9	0.68	5.1	6.8	3.6	4.3	3.5	42	37	IBExU02ATEX1115/28	0.01550	48.0
IE3-K11R 132 S6 Ex e IIC	T1-T3	±10 %	55	2.60	26	960	IE3-	86.0	86.9	85.9	0.80	5.9	6.0	2.1	3.1	1.3	25	21	PTB08ATEX3037/18	0.023	60
IE3-K11R 132 M6 Ex e IIC	T1-T3	±10 %	50	3.50	35	965	IE3-	86.7	87.3	86.5	0.82	7.6	5.1	1.7	2.4	1.5	50	43	PTB08ATEX3037/19	0.053	75
IE3-K11R 132 MX6 Ex e IIC	T1-T3	±10 %	55	4.80	47	971	IE3-	88.5	88.7	87.4	0.80	10.2	6.6	2.2	3.1	1.8	44	38	PTB08ATEX3037/20	0.0636	105
IE3-K11R 160 M6 Ex e IIC	T1-T3	±10 %	55	6.60	65	975	IE3-	89.1	89.2	87.9	0.83	13.5	5.7	2.1	2.5	1.7	78	34	PTB08ATEX3038/27	0.145	145
IE3-K11R 160 L6 Ex e IIC	T1-T3	±10 %	55	9.70	95	975	IE3-	90.0	89.7	88.3	0.83	19.6	6.9	2.8	3.0	2.0	40	11	IBExU99ATEX1105/104	0.166	160
IE3-K11R 180 L6 Ex e IIC	T1-T3	±10 %	50	13.2	129	980	IE3-	91.2	91.4	90.5	0.87	26	6.2	2.1	2.8	1.9	55	22	IBExU99ATEX1138/48	0.268	215
IE3-K11R 200 L6 Ex e IIC	T1-T3	±10 %	55	16.5	160	983	IE3-	91.5	91.5	90.3	0.88	31	7.5	2.3	3.1	2.0	45	18	IBExU99ATEX1143/56	0.648	325
IE3-K11R 200 LX6 Ex e IIC	T1-T3	±10 %	55	20.0	194	984	IE3-	92.0	91.5	90.1	0.88	38	7.8	2.4	3.0	1.9	40	14	IBExU99ATEX1143/48	0.782	360
IE3-K11R 225 M6 Ex e IIC	T1-T3	±10 %	45	27.0	262	984	IE3-	92.7	92.1	90.9	0.85	52	7.3	2.7	2.9	2.1	28	7	IBExU99ATEX1144/45	0.92	420
IE3-K11R 250 M6 Ex e IIC	T1-T3	±10 %	55	33.0	320	986	IE3-	93.1	92.6	91.6	0.86	62.5	6.5	2.4	2.5	1.7	30	11	IBExU99ATEX1131/39	1.48	550
IE3-K11R 280 S6 Ex e IIC	T1-T3	±10 %	50	40.0	386	989	IE3-	93.5	93.1	92.1	0.86	76	7.5	2.0	2.6	1.7	40	19	IBExU99ATEX1030/47	2.63	715
IE3-K11R 280 M6 Ex e IIC	T1-T3	±10 %	50	46.0	444	990	IE3-	93.8	93.6	93.0	0.87	86	7.6	2.1	2.6	1.7	30	13	IBExU99ATEX1030/56	2.63	740
	T1-T3	±10 %	50	50.0	482	990	IE3-	93.9	93.7	93.3	0.88	94	7.0	1.9	2.4	1.6	28	11	IBExU99ATEX1030/57		
IE3-K11R 315 S6 Ex e IIC	T1-T3	±10 %	40	64.0	618	989	IE3-													3.6	880
IE3-K11R 315 M6 Ex e IIC	T1-T3	±10 %	40	76.0	732	992	IE3-													6	1050
IE3-K11R 315 MV6 Ex e IIC	T1-T3	±10 %	40	85.0	820	990	IE3-													6.67	1250
IE3-K11R 315 L6 Ex e IIC	T1-T3	±10 %	40	95	914	993	IE3-	95.0	94.6	93.9	0.87	175	8.0	2.2	2.5	1.5	35	14	IBExU99ATX1137/87	8.6	1470
IE3-K11R 315 LX6 Ex e IIC	T1-T3	±10 %	40	110	1061	990	IE3-													8.6	1460
IE3-K12R 355 M6 Ex e IIC	T1-T3	±10 %	40	125	1202	993	IE3-													8.2	1650
IE3-K42R 355 MX6 Ex e	T1-T3	±10 %	40	160	1539	993	IE3-													12.1	2200
IE3-K42R 355 L6 Ex e	T1-T3	±10 %	40	180	1731	993	IE3-													14	2400
IE3-K42R 355 LX6 Ex e	T1-T3	±10 %	40	200	1923	993	IE3-													14	2400
IE3-K42R 400 M6 Ex e	T1-T3	±10 %	40	230	2212	993	IE3-													16.54	2900
IE3-K42R 400 L6 Ex e	T1-T3	±10 %	40	250	2404	993	IE3-													20.63	3200
Synchronous speed 750 rpm – 8-pole version																					
IE3-K11R 132 S8 Ex e IIC	T1-T3	±10 %	55	1.9	25	713	IE3-	82.1	82.8	81.2	0.71	4.8	4.7	1.9	2.7	1.8	60	50	IBExU99ATEX1142/101	0.018	60
IE3-K11R 132 M8 Ex e IIC	T1-T3	±10 %	55	2.6	34	725	IE3-	84.4	84.6	82.6	0.70	6.4	4.4	1.6	2.2	1.5	65	55	IBExU99ATEX1142/99	0.043	80
IE3-K11R 160 M8 Ex e IIC	T1-T3	±10 %	40	3.5	46	720	IE3-													0.053	86
IE3-K11R 160 MX8 Ex e IIC	T1-T3	±10 %	40	4.8	64	720	IE3-													0.113	114
IE3-K11R 160 L8 Ex e IIC	T1-T3	±10 %	50	6.6	86	730	IE3-	88.1	88.2	86.6	0.75	14.7	5.2	2.1	2.6	1.9	70	35	IBExU99ATEX1105/130	0.145	150
IE3-K11R 180 L8 Ex e IIC	T1-T3	±10 %	55	9.7	126	734	IE3-	89.6	89.5	87.8	0.75	21	5.8	2.1	2.8	1.8	55	30	IBExU99ATEX1138/63	0.228	195
IE3-K11R 200 L8 Ex e IIC	T1-T3	±10 %	55	13.2	173	730	IE3-	89.5	89.7	88.7	0.77	29	5.2	2.0	2.4	1.6	50	16	IBExU99ATEX1143/67	0.268	230
IE3-K11R 225 S8 Ex e IIC	T1-T3	±10 %	40	16.5	216	730	IE3-													0.44	265
IE3-K11R 225 M8 Ex e IIC	T1-T3	±10 %	40	20.0	260	735	IE3-													0.825	360
IE3-K11R 250 M8 Ex e IIC	T1-T3	±10 %	40	27.0	350	737	IE3-													1.35	465
IE3-K11R 280 S8 Ex e IIC	T1-T3	±10 %	40	33.0	427	738	IE3-	92.2	92.3	91.2	0.79	68	5.9	2.3	2.4	1.8	35	12		1.55	570
IE3-K11R 280 M8 Ex e IIC	T1-T3	±10 %	40	40.0	516	740	IE3-													2.63	690
IE3-K11R 315 S8 Ex e IIC	T1-T3	±10 %	50	50	644	741	IE3-	93.5	93.7	93.1	0.80	100	6.5	1.8	2.2	1.5	45	18	IBExU99ATEX1137/94	3.33	845
IE3-K11R 315 M8 Ex e IIC	T1-T3	±10 %	40	68	878	740	IE3-													3.33	800
IE3-K11R 315 MY8 Ex e IIC	T1-T3	±10 %	40	80	1030	742	IE3-													6	1050
IE3-K11R 315 L8 Ex e IIC	T1-T3	±10 %	40	95	1221	743	IE3-													6.76	1250
IE3-K11R 315 LX8 Ex e IIC	T1-T3	±10 %	40	115	1484	740	IE3-													8.71	1430
IE3-K12R 355 M8 Ex e IIC	T1-T3	±10 %	40	140	1807	740	IE3-													9.5	1850
IE3-K42R 355 MX8 Ex e	T1-T3	±10 %	40	180	2323	740	IE3-													13.4	2200
IE3-K42R 355 L8 Ex e	T1-T3	±10 %	40	150	1936	740	IE3-													15.8	2400
IE3-K42R 355 LX8 Ex e	T1-T3	±10 %	40	180	2323	740	IE3-													15.8	2400
IE3-K42R 400 M8 Ex e	T1-T3	±10 %	40	200	2581	740	IE3-													17.94	3000
IE3-K42R 400 L8 Ex e	T1-T3	±10 %	40	230	2940	747	IE3-	95.2	95.2	95	0.77	470	7.5	1.3	2.3	1.2	10	26	IBExU15ATEX1075/02	22.34	3330

Optionally in dust-protected version, protection type: Protection by enclosure "tb" to EN 60079-31
for operation in Zone 21 (IBExU 02ATEX 1019 for series K1.R), degree of protection IP 65, double marking on rating plate.
Other voltages and frequencies upon request. Changes are possible for motors which are not yet certified.

Three-phase motors with squirrel-cage rotor, Premium Efficiency IE3

Type of explosion protection – Increased safety „e“ („eb“)

for operation in Zone 1 according to EN 60079-7

according to VIK Recommendation 1, Three-Phase Asynchronous Motors – Technical Requirements 03.2011

for rated voltage, temperature classes T1, T2 and T3
with surface cooling, duty type S1, continuous duty
thermal class F, degree of protection IP 55, 50 Hz

Motor selection data														Design point 400 V, 50 Hz						
Type	Temperature class	Voltage tolerance	max. Coolant temperature °C	P _B kW	M _B Nm	n _B rpm	η _B (IEC/EN 60034-30-1)			cosφ _B	I _B A	I _A /I _B	M _A /M _B	M _S /M _B	M _K /M _B	t _E -time	ATEX no.	J	m	
							100 %	75 %	50 %	-	-	-	-	-	s	s		kgm ²	kg	
Synchronous speed 3000 rpm – 2-pole version																				
IE3-K11R 315 S2 Ex e IIC	T1-T3			68	218	2975	IE3-											1.44	820	
IE3-K11R 315 S2G Ex e IIC	T1-T3	±10 %		68	218	2978	IE3-94.7	94.6	93.9	0.89	123	7.7	1.3	2.2	1.2	20	8	IBExU99ATEX1137/95	1.44	850
IE3-K11R 315 M2 Ex e IIC	T1-T3			80	257	2975	IE3-											1.76	980	
IE3-K11R 315 M2G Ex e IIC	T1-T3			80	257	2975	IE3-											1.76	980	
IE3-K11R 315 MY2 Ex e IIC	T1-T3			110	353	2980	IE3-95.2	95.2	94.8	0.93	180	6.9	1.0	2.4	0.7	35	11		2.82	1270
IE3-K11R 315 MY2G Ex e IIC	T1-T3	±10 %		110	353	2980	IE3-95.2	94.8	94.0	0.93	190	6.4	1.0	2.4	0.7	30	11	IBExU99ATEX1137/92	2.82	1270
IE3-K11R 315 L2 Ex e IIC	T1-T3			125	401	2980	IE3-											3.66	1450	
IE3-K11R 315 L2G Ex e IIC	T1-T3			125	401	2980	IE3-											3.66	1450	
IE3-K11R 315 LX2 Ex e IIC	T1-T3			150	480	2985	IE3-											4.43	1630	
IE3-K11R 315 LX2G Ex e IIC	T1-T3			150	480	2985	IE3-											4.43	1630	
IE3-K12R 355 M2 Ex e IIC	T1-T3			190	609	2980	IE3-											4.2	2000	
IE3-K42R 355 MX2 Ex e IIC	T1-T3			220	705	2980	IE3-											5.5	2200	
IE3-K42R 355 L2 Ex e IIC	T1-T3			250	801	2980	IE3-											7.1	2445	
IE3-K42R 400 M2 Ex e IIC	T1-T3						IE3-											8.44	3060	
IE3-K42R 400 L2 Ex e IIC	T1-T3						IE3-											10.41	3400	

Optionally in dust-protected version, protection type: Protection by enclosure "tb" to EN 60079-31
for operation in Zone 21 (IBExU 02ATEX 1019 for series K1.R), degree of protection IP 65, double marking on rating plate.
Other voltages and frequencies upon request. Changes are possible for motors which are not yet certified.

Three-phase motors with squirrel-cage rotor, Premium Efficiency IE3

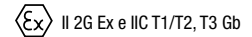

Type of explosion protection – Increased safety „e“ („eb“)

for operation in Zone 1 according to EN 60079-7

according to VIK Recommendation 1, Three-Phase Asynchronous Motors – Technical Requirements 03.2011

for rated voltage, temperature classes T1, T2 and T3 with surface cooling, duty type S1, continuous duty thermal class F, degree of protection IP 55, 50 Hz

Motor selection data															Design point 400 V, 50 Hz					
Type	Temperature class	Voltage tolerance	max. Coolant temperature °C	P _B kW	M _B Nm	n _B rpm	η _B (IEC/EN 60034-30-1)			cosφ _B	I _B 400 V A	I _A /I _B	M _N /M _B	M _S /M _B	M _K /M _B	t _E -time	ATEX no.	J	m	
							100 %	75 %	50 %	-						T2 s	T3 s	kgm ²	kg	
Synchronous speed 1500 rpm – 4-pole version																				
IE3-KPER 63 G4 Ex e IIC	T1-T3	±10 %	45	0.12	0.9	1355	IE3- 64.8	65.2	62.3	0.75	0.37	3.3	1.9	1.9	2.1	75	65	IBExU02ATEX1110/14	0.0002	5.2
IE3-KPR 63 G4 Ex e IIC	T1-T3	±5 %	55	0.18	1.2	1405	IE3- 69.9	68.0	62.2	0.7	0.55	4.1	2.1	2.1	2.6	70	60	IBExU02ATEX1110/29	0.0005	7.1
IE3-KPR 71 K4 Ex e IIC	***	***	***	0.25	***	***	***	***	***	***	***	***	***	***	***	***	***	***	***	***
IE3-KPR 71 G4 Ex e IIC	T1-T3	±10 %	60	0.37	2.5	1440	IE3- 77.3	77.6	75	0.69	1.02	5.8	2.9	2.9	3.3	45	40	IBExU02ATEX1111/39	0.0011	11.0
IE3-KPR 80 K4 Ex e IIC	***	***	***	0.55	***	***	***	***	***	***	***	***	***	***	***	***	***	***	***	***
IE3-KPR 80 GX4 Ex e IIC	T1-T3	±10 %	60	0.75	5.0	1445	IE3- 82.5	81.9	79	0.74	1.78	7.3	3.4	4.2	3.4	22	19	IBExU02ATEX1112/59	***	17.5
IE3-KPR 90 S4 Ex e IIC	T1-T3	±10 %	65	1.00	6.6	1450	IE3- 83.7	83.3	80.6	0.8	2.25	7.8	3.3	4.0	3.1	35	30	IBExU02ATEX1113/46	0.0045	28.0
IE3-KPR 90 LX4 Ex e IIC	T1-T3	±10 %	60	1.35	9.0	1435	IE3- 84.9	85.0	83.4	0.84	2.85	7.2	3.3	3.6	2.8	30	27	IBExU02ATEX1113/47	0.0058	31.0
IE3-KPR 100 L4 Ex e IIC	T1-T3	±10 %	65	2.00	13.2	1445	IE3- 86.3	86.7	85.4	0.81	4.25	7.5	3.3	3.8	3.0	30	26	IBExU02ATEX1114/45	0.011	45.0
IE3-KPR 100 LZ4 Ex e IIC	T1-T3	±10 %	65	2.50	16.5	1445	IE3- 87.1	87.6	86.4	0.83	5.2	7.6	2.9	3.7	2.7	28	24	IBExU02ATEX1114/44	0.013	50.0
IE3-KPR 112 M4 Ex e IIC	T1-T3	±10 %	55	3.6	24	1452	IE3- 88.7	89.9	90.0	0.89	6.9	7.2	1.9	3.1	1.6	17	15	***	0.02	65
IE3-K11R 112 M4 Ex e IIC	T1-T3	±10 %	55	3.6	24	1452	IE3- 88.7	89.9	90.0	0.89	6.9	7.2	1.9	3.1	1.6	17	15	PTB09ATEX3004/08	0.02	65
IE3-K11R 132 S4 Ex e IIC	T1-T3	±10 %	55	5.0	33	1465	IE3- 90.4	91.1	90.6	0.86	9.7	6.8	1.9	2.9	1.6	30	28	IBExU99ATEX1142/84	0.035	90
IE3-K11R 132 M4 Ex e IIC	T1-T3	±10 %	55	6.8	45	1457	IE3- 90.2	90.8	90.7	0.86	13.4	7.1	2.0	3.1	1.5	20	18	IBExU99ATEX1142/80	0.035	88
IE3-K11R 160 M4 Ex e IIC	T1-T3	±10 %	55	10.0	65	1471	IE3- 91.2	91.2	90.4	0.85	19.6	7.2	2.3	3.0	2.1	26	9	IBExU99ATEX1105/102	0.078	125
IE3-K11R 160 L4 Ex e IIC	T1-T3	±10 %	55	13.5	88	1473	IE3- 92.0	92.1	91.5	0.87	26	7.8	2.6	3.1	2.1	18	7	PTB08ATEX3038/26	0.115	168
IE3-K11R 180 M4 Ex e IIC	T1-T3	±10 %	55	15.0	97	1478	IE3- 92.2	91.9	90.8	0.84	29.5	7.3	1.9	2.7	1.7	35	12	IBExU99ATEX1138/51	0.168	215
	T1,T2	±10 %	55	17	110	1473	IE3- 92.4	91.9	91.2	0.86	32.5	6.7	1.6	2.4	1.5	35		IBExU99ATEX1138/52		
IE3-K11R 180 L4 Ex e IIC	T1-T3	±10 %	50	17.50	113	1479	IE3- 92.6	92.5	91.4	0.86	33.5	8.0	2.0	2.9	1.7	30	12	IBExU99ATEX1138/55	0.168	240
	T1,T2	±10 %	45	20	129	1476	IE3- 92.8	92.5	91.8	0.86	38	7.0	1.7	2.5	1.5	30		IBExU99ATEX1138/56		
IE3-K11R 200 L4C Ex e IIC	T1-T3	±10 %	55	24.0	154	1485	IE3- 93.2	93.7	93.3	0.87	45	7.2	1.4	2.3	1.2	35	11	IBExU99ATEX1143/53	0.313	345
	T1,T2	±10 %	55	27	174	1481	IE3- 93.4	94.6	94.3	0.87	51	6.3	1.3	2.1	1.1	30		IBExU99ATEX1138/54		
IE3-K11R 225 S4 Ex e IIC	T1-T3	±10 %	50	30.00	193	1483	IE3- 93.8	94.2	93.9	0.85	58	7.8	2.2	2.4	1.7	26	10	IBExU99ATEX1144/37	0.525	445
	T1,T2	±10 %	50	33	213	1480	IE3- 93.7	93.8	93.9	0.85	64	7.0	2.0	2.2	1.6	24		IBExU99ATEX1144/38		
IE3-K11R 225 M4 Ex e IIC	T1-T3	±10 %	40	36.00	232	1481	IE3- 93.9	94.3	94.2	0.84	69	7.2	2.0	2.2	1.6	21	7	IBExU99ATEX1144/39	0.525	450
	T1,T2	±10 %	40	40	259	1477	IE3- 94.1	94.1	94.2	0.85	78	6.4	1.8	2.0	1.4	17		IBExU99ATEX1144/40		
IE3-K11R 250 M4 Ex e IIC	T1-T3	±10 %	45	44.0	283	1486	IE3- 94.2	94.0	93.4	0.85	84	7.5	1.9	2.2	1.5	28	9	IBExU99ATEX1131/35	0.95	545
	T1,T2	±10 %	45	50	322	1484	IE3- 94.4	94.1	93.7	0.85	96	6.5	1.7	1.9	1.3	24		IBExU99ATEX1131/37		
IE3-K11R 280 S4 Ex e IIC	T1-T3	±10 %	45	58.0	372	1488	IE3- 95.4	95.5	95.0	0.82	113	7.8	1.4	2.2	1.2	35	16	IBExU99ATEX1030/52	1.96	775
	T1,T2	±10 %	45	68	438	1484	IE3- 95.0	95.4	95.2	0.83	132	6.7	1.2	1.8	1.0	30		IBExU99ATEX1030/53		
IE3-K11R 280 M4 Ex e IIC	T1-T3	±10 %	55	70.0	449	1488	IE3- 95.0	95.1	94.6	0.83	135	8.0	1.6	2.3	1.4	23	8	IBExU99ATEX1030/54	2.27	855
	T1,T2	±10 %	50	80	514	1485	IE3- 95.1	95.0	94.9	0.83	154	7.0	1.4	2.0	1.2	20		IBExU99ATEX1030/55		
IE3-K11R 315 S4 Ex e IIC	T1-T3	±10 %	40	84	539	1489	IE3- 95.1	95.1	94.6	0.84	161	8.0	1.5	2.2	1.4	23	8	IBExU99ATEX1030/85	2.73	995
	T1,T2	±10 %	40	100	643	1485	IE3- 95.3	95.2	95.0	0.84	194	6.6	1.2	1.8	1.1	18		IBExU99ATEX1030/86		
IE3-K11R 315 M4 Ex e IIC	T1-T3	±10 %	50	100	641	1491	IE3- 95.3	95.2	94.5	0.85	186	7.7	1.3	2.4	1.0	26	7	IBExU99ATEX1137/90	4.02	1175
	T1-T3	±10 %	45	120	770	1489	IE3- 95.5	95.3	95.0	0.86	225	6.4	1.1	2.0	0.9	21		IBExU99ATEX1137/91		
IE3-K11R 315 MY4 Ex e IIC	T1-T3	±10 %	40	115	737	1490	IE3- 95.5	95.3	94.5	0.85	218	6.9	1.1	2.1	0.9	35	14	IBExU99ATEX1137/89	4.82	1200
IE3-K11R 315 L4 Ex e IIC	T1-T3			135	865	1491	IE3-												5.93	1450
IE3-K11R 315 LX4 Ex e IIC	T1-T3			170	1090	1490	IE3-												6.82	1630
IE3-K12R 355 M4 Ex e IIC	T1-T3			215	1375	1493	IE3- 96.0	95.8	95.1	0.84	390	7.9	1.4	2.6	1.2	21	7	IBExU01ATEX1009/18	7.9	2150
IE3-K42R 355 MX4 Ex e IIC	T1-T3			240	1538	1490	IE3-												9.5	2400
IE3-K42R 355 L4 Ex e IIC	T1-T3			275	1758	1494	IE3-												10	2500
IE3-K42R 400 M4 Ex e IIC	T1-T3			300	1918	1494	IE3-												12.6	2900
IE3-K42R 400 L4 Ex e IIC	T1-T3			320	2046	1494	IE3-												16.29	3450

Optionally in dust-protected version, protection type: Protection by enclosure "tb" to EN 60079-31 for operation in Zone 21 (IBExU 02ATEX 1019 for series K1.R), degree of protection IP 65, double marking on rating plate. Other voltages and frequencies upon request. Changes are possible for motors which are not yet certified. ***) upon request

Three-phase motors with squirrel-cage rotor, Premium Efficiency IE3

 II 2G Ex e IIC T1/T2, T3 Gb

Type of explosion protection – Increased safety „e“ („eb“)

for operation in Zone 1 according to EN 60079-7

according to VIK Recommendation 1, Three-Phase Asynchronous Motors – Technical Requirements 03.2011

for rated voltage, temperature classes T1, T2 and T3
 with surface cooling, duty type S1, continuous duty
 thermal class F, degree of protection IP 55, 50 Hz

Motor selection data																			Design point 400 V, 50 Hz			
Type	Temperature class	Voltage tolerance	max. Coolant temperature °C	P _B kW	M _B Nm	n _B rpm	η _B (IEC/EN 60034-30-1)			cosφ _B	I _B 400 V A	I _A /I _B	M _A /M _B	M _S /M _B	M _K /M _B	t _e -time		ATEX no.	J kgm ²	m kg		
							100%	75%	50%							T2	T3					
							-	-	-							s	s					
Synchronous speed 1000 rpm – 6-pole version																						
IE3-KPR 80 G6 Ex e IIC	T1-T3	±10 %	60	0.55	5.60	945	IE3-77.2	77.5	75	0.48	1.53	4.2	2.2	2.4	2.2	84	73	IBExU02ATEX1112/53	0.00425	18		
IE3-KPR 90 L6 Ex e IIC	T1-T3	±10 %	50	0.95	9.45	960	IE3-80.2	78.6	74.7	0.67	2.65	5.6	3.1	3.5	2.8	46	41	IBExU02ATEX1113/42	0.00720	30.0		
IE3-KPR 100 LX6 Ex e IIC	T1-T3	±10 %	50	1.30	12.9	960	IE3-81.8	81.5	78.6	0.72	3.20	6.0	2.4	3.2	2.4	97	87	IBExU02ATEX1114/39	0.01390	36.0		
IE3-KPER 112 MV6 Ex e IIC	T1-T3	±10 %	50	1.90	18.8	965	IE3-83.6	82.6	78.9	0.68	5.1	6.8	3.6	4.3	3.5	42	37	IBExU02ATEX1115/28	0.01550	48.0		
IE3-K11R 132 S6 Ex e IIC	T1-T3	±10 %	55	2.60	26	960	IE3-86.0	86.9	85.9	0.80	5.9	6.0	2.1	3.1	1.3	25	21	PTB08ATEX3037/18	0.023	60		
IE3-K11R 132 M6 Ex e IIC	T1-T3	±10 %	50	3.50	35	965	IE3-86.7	87.3	86.5	0.82	7.6	5.1	1.7	2.4	1.5	50	43	PTB08ATEX3037/19	0.053	75		
IE3-K11R 132 MX6 Ex e IIC	T1-T3	±10 %	55	4.80	47	971	IE3-88.5	88.7	87.4	0.80	10.2	6.6	2.2	3.1	1.8	44	38	PTB08ATEX3037/20	0.0636	105		
IE3-K11R 160 M6 Ex e IIC	T1-T3	±10 %	55	6.60	65	975	IE3-89.1	89.2	87.9	0.83	13.5	5.7	2.1	2.5	1.7	78	34	PTB08ATEX3038/27	0.145	145		
IE3-K11R 160 L6 Ex e IIC	T1-T3	±10 %	55	9.70	95	975	IE3-90.0	89.7	88.3	0.83	19.6	6.9	2.8	3.0	2.0	40	11	IBExU99ATEX1105/104	0.166	160		
IE3-K11R 180 L6 Ex e IIC	T1-T3	±10 %	50	13.2	129	980	IE3-91.2	91.4	90.5	0.87	26	6.2	2.1	2.8	1.9	55	22	IBExU99ATEX1138/48	0.268	215		
IE3-K11R 200 L6 Ex e IIC	T1-T3	±10 %	55	16.5	160	983	IE3-91.5	91.5	90.3	0.88	31	7.5	2.3	3.1	2.0	45	18	IBExU99ATEX1143/56	0.648	325		
IE3-K11R 200 LX6 Ex e IIC	T1-T3	±10 %	55	20.0	194	984	IE3-92.0	91.5	90.1	0.88	38	7.8	2.4	3.0	1.9	40	14	IBExU99ATEX1143/48	0.782	360		
IE3-K11R 225 M6 Ex e IIC	T1-T3	±10 %	45	27.0	262	984	IE3-92.7	92.1	90.9	0.85	52	7.3	2.7	2.9	2.1	28	7	IBExU99ATEX1144/45	0.92	420		
IE3-K11R 250 M6 Ex e IIC	T1-T3	±10 %	55	33.0	320	986	IE3-93.1	92.6	91.6	0.86	62.5	6.5	2.4	2.5	1.7	30	11	IBExU99ATEX1131/39	1.48	550		
IE3-K11R 280 S6 Ex e IIC	T1-T3	±10 %	50	40.0	386	989	IE3-93.5	93.1	92.1	0.86	76	7.5	2.0	2.6	1.7	40	19	IBExU99ATEX1030/47	2.63	715		
IE3-K11R 280 M6 Ex e IIC	T1-T3	±10 %	50	46.0	444	990	IE3-93.8	93.6	93.0	0.87	86	7.6	2.1	2.6	1.7	30	13	IBExU99ATEX1030/56	2.63	740		
IE3-K11R 280 L6 Ex e IIC	T1-T3	±10 %	50	50.0	482	990	IE3-93.9	93.7	93.3	0.88	94	7.0	1.9	2.4	1.6	28	11	IBExU99ATEX1030/57				
IE3-K11R 315 S6 Ex e IIC	T1-T3			64.0	618	989	IE3-												3.6	880		
IE3-K11R 315 M6 Ex e IIC	T1-T3			76.0	732	992	IE3-												6	1050		
IE3-K11R 315 MV6 Ex e IIC	T1-T3			85.0	820	990	IE3-												6.67	1250		
IE3-K11R 315 L6 Ex e IIC	T1-T3	±10 %	40	95	914	993	IE3-95.0	94.6	93.9	0.87	175	8.0	2.2	2.5	1.5	35	14	IBExU99ATEX1137/87	8.6	1470		
IE3-K11R 315 LX6 Ex e IIC	T1-T3			110	1061	990	IE3-												8.6	1460		
IE3-K12R 355 M6 Ex e IIC	T1-T3			125	1202	993	IE3-												8.2	1650		
IE3-K42R 355 MX6 Ex e IIC	T1-T3	±10 %	40	160	1539	993	IE3-												12.1	2200		
IE3-K42R 355 L6 Ex e IIC	T1-T3	±10 %	40	180	1731	993	IE3-												14	2400		
IE3-K42R 355 LX6 Ex e IIC	T1-T3	±10 %	40	200	1923	993	IE3-												14	2400		
IE3-K42R 400 M6 Ex e IIC	T1-T3	±10 %	40	230	2212	993	IE3-												16.54	2900		
IE3-K42R 400 L6 Ex e IIC	T1-T3	±10 %	40	250	2404	993	IE3-												20.63	3200		
Synchronous speed 750 rpm – 8-pole version																						
IE3-K11R 132 S8 Ex e IIC	T1-T3	±10 %	55	1.9	25	713	IE3-82.1	82.8	81.2	0.71	4.8	4.7	1.9	2.7	1.8	60	50	IBExU99ATEX1142/101	0.018	60		
IE3-K11R 132 M8 Ex e IIC	T1-T3	±10 %	55	2.6	34	725	IE3-84.4	84.6	82.6	0.70	6.4	4.4	1.6	2.2	1.5	65	55	IBExU99ATEX1142/99	0.043	80		
IE3-K11R 160 M8 Ex e IIC	T1-T3			3.5	46	720	IE3-												0.053	86		
IE3-K11R 160 MX8 Ex e IIC	T1-T3			4.8	64	720	IE3-												0.113	114		
IE3-K11R 160 L8 Ex e IIC	T1-T3	±10 %	50	6.6	86	730	IE3-88.1	88.2	86.6	0.75	14.7	5.2	2.1	2.6	1.9	70	35	IBExU99ATEX1105/130	0.145	150		
IE3-K11R 180 L8 Ex e IIC	T1-T3	±10 %	55	9.7	126	734	IE3-89.6	89.5	87.8	0.75	21	5.8	2.1	2.8	1.8	55	30	IBExU99ATEX1138/63	0.228	195		
IE3-K11R 200 L8 Ex e IIC	T1-T3	±10 %	55	13.2	173	730	IE3-89.5	89.7	88.7	0.77	29	5.2	2.0	2.4	1.6	50	16	IBExU99ATEX1143/67	0.268	230		
IE3-K11R 225 S8 Ex e IIC	T1-T3			16.5	216	730	IE3-												0.44	265		
IE3-K11R 225 M8 Ex e IIC	T1-T3			20.0	260	735	IE3-												0.825	360		
IE3-K11R 250 M8 Ex e IIC	T1-T3			27.0	350	737	IE3-												1.35	465		
IE3-K11R 280 S8 Ex e IIC	T1-T3	±10 %		33.0	427	738	IE3-92.2	92.3	91.2	0.79	68	5.9	2.3	2.4	1.8	35	12		1.55	570		
IE3-K11R 280 M8 Ex e IIC	T1-T3			40.0	516	740	IE3-												2.63	690		
IE3-K11R 315 S8 Ex e IIC	T1-T3	±10 %	50	50	644	741	IE3-93.5	93.7	93.1	0.80	100	6.5	1.8	2.2	1.5	45	18	IBExU99ATEX1137/94	3.33	845		
IE3-K11R 315 M8 Ex e IIC	T1-T3			68	878	740	IE3-												3.33	800		
IE3-K11R 315 MY8 Ex e IIC	T1-T3			80	1030	742	IE3-												6	1050		
IE3-K11R 315 L8 Ex e IIC	T1-T3			95	1221	743	IE3-												6.76	1250		
IE3-K11R 315 LX8 Ex e IIC	T1-T3			115	1484	740	IE3-												8.71	1430		
IE3-K12R 355 M8 Ex e IIC	T1-T3			140	1807	740	IE3-												9.5	1850		
IE3-K42R 355 MX8 Ex e IIC	T1-T3	±10 %	40	180	2323	740	IE3-												13.4	2200		
IE3-K42R 355 L8 Ex e IIC	T1-T3	±10 %	40	150	1936	740	IE3-												15.8	2400		
IE3-K42R 355 LX8 Ex e IIC	T1-T3	±10 %	40	180	2323	740	IE3-												15.8	2400		
IE3-K42R 400 M8 Ex e IIC	T1-T3	±10 %	40	200	2581	740	IE3-												17.94	3000		
IE3-K42R 400 L8 Ex e IIC	T1-T3	±10 %	40	230	2940	747	IE3-95.2	95.2	95	0.77	470	7.5	1.3	2.3	1.2	10	26	IBExU15ATEX1075/02	22.34	3330		

Optionally in dust-protected version, protection type: Protection by enclosure "tb" to EN 60079-31 for operation in Zone 21 (IBExU 02ATEX 1019 for series K1.R), degree of protection IP 65, double marking on rating plate. Other voltages and frequencies upon request. Changes are possible for motors which are not yet certified.

Three-phase motors with squirrel-cage rotor, High Efficiency IE2 Type of explosion protection – Increased safety „e“ („eb“) for operation in Zone 1 according to EN 60079-7

II 2G Ex e IIC T1/T2, T3 Gb

for rated voltage, temperature classes T1, T2 and T3
with surface cooling, duty type S1, continuous duty
thermal class F, degree of protection IP 55, 50 Hz

Motor selection data															Design point 400 V, 50 Hz					
Type	Temperature class	Voltage tolerance	max. Coolant temperature °C	P _B kW	M _B Nm	n _B rpm	η _B (IEC/EN 60034-30-1)			cosφ _B	I _B 400 V A	I _A /I _B	M _A /M _B	M _S /M _B	M _K /M _B	t _E -time		ATEX no.	J kgm ²	m kg
							100 %	75 %	50 %							T2 s	T3 s			
Synchronous speed 3000 rpm – 2-pole version																				
IE2-K11R 315 S2 Ex e IIC	T1-T3	±5 %	55	68	216	2975	IE2-94.2	94.3	93.7	0.89	118	7.7	1.3	2.1	1.2	24	9	IBExU99ATEX1137/74	1.44	850
	T1, T2	±5 %	55	68	216	2975	IE2-94.2	94.3	93.7	0.89	118	7.7	1.3	2.1	1.2	24		IBExU99ATEX1137/74		
IE2-K11R 315 S2G Ex e IIC	T1-T3	±5 %		68	216	2975	IE2-94.2	94.3	93.7	0.89	118	7.7	1.3	2.1	1.2	-	-		1.44	850
	T1, T2	±5 %		68	216	2975	IE2-94.2	94.3	93.7	0.89	118	7.7	1.3	2.1	1.2	-	-			
IE2-K11R 315 M2 Ex e IIC	T1-T3	±5 %	50	80	255	2973	IE2-93.9	93.7	92.7	0.89	138	7.4	1.2	1.8	1.0	23	8	IBExU99ATEX1137/76	1.76	970
	T1, T2	±5 %	50	80	255	2973	IE2-93.9	93.7	92.7	0.89	138	7.4	1.2	1.8	1.0	23		IBExU99ATEX1137/76		
IE2-K11R 315 M2G Ex e IIC	T1-T3	±5 %		80	255	2973	IE2-93.9	93.7	92.7	0.89	138	7.4	1.2	1.8	1.0	-	-		1.76	970
	T1, T2	±5 %		80	255	2973	IE2-93.9	93.7	92.7	0.89	138	7.4	1.2	1.8	1.0	-	-			
IE2-K11R 315 MY2 Ex e IIC	T1-T3	±5 %	40	110	349	2980	IE2-95.1	95.2	94.8	0.93	180	6.9	1.0	2.4	0.7	35	11	IBExU99ATEX1137/64	2.82	1270
	T1, T2	±5 %	40	110	349	2970	IE2-95.1	95.2	94.8	0.93	180	6.9	1.0	2.4	0.7	35		IBExU99ATEX1137/64		
IE2-K11R 315 MY2G Ex e IIC	T1-T3	±5 %		110	349	2980	IE2-95.1	95.2	94.8	0.93	180	6.9	1.0	2.4	0.7	-	-		2.82	1200
	T1, T2	±5 %		110	349	2970	IE2-95.1	95.2	94.8	0.93	180	6.9	1.0	2.4	0.7	-	-			
IE2-K11R 315 L2 Ex e IIC	T1-T3			125	401	2980	IE2-												3.66	1450
IE2-K11R 315 L2G Ex e IIC	T1-T3			125	401	2980	IE2-												3.66	1450
IE2-K11R 315 LX2 Ex e IIC	T1-T3			150	480	2985	IE2-												4.43	1630
IE2-K11R 315 LX2G Ex e IIC	T1-T3			150	480	2985	IE2-												4.43	1630
IE2-K12R 355 M2 Ex e IIC	T1-T3			190	609	2980	IE2-												4.2	2000
IE2-K12R 355 MX2 Ex e IIC	T1-T3			220	705	2980	IE2-												4.5	2200
IE2-K12R 355 L2 Ex e IIC	T1-T3			250	801	2980	IE2-												7.1	2400

Optionally in dust-protected version, protection type: Protection by enclosure "tb" to EN 60079-31
for operation in Zone 21 (IBExU 02ATEX 1019 for series K1.R), degree of protection IP 65, double marking on rating plate.
Other voltages and frequencies upon request. Changes are possible for motors which are not yet certified.

Three-phase motors with squirrel-cage rotor, High Efficiency IE2
Type of explosion protection – Increased safety „e“ („eb“)
for operation in Zone 1 according to EN 60079-7

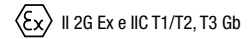

for rated voltage, temperature classes T1, T2 and T3
 with surface cooling, duty type S1, continuous duty
 thermal class F, degree of protection IP 55, 50 Hz

Motor selection data																	Design point 400 V, 50 Hz				
Type	Temperature class	Voltage tolerance	max. Coolant temperature °C	P _B kW	M _B Nm	n _B rpm	η _B (IEC/EN 60034-30-1)			cosφ _{lg}	I _B 400 V A	I _A /I _B	M _A /M _B	M _S /M _B	M _K /M _B	t _E -time		ATEX no.	J kgm ²	m kg	
							100 %	75 %	50 %							T2 s	T3 s				
Synchronous speed 1500 rpm – 4-pole version																					
IE2-KPR 80 G4 Ex e IIC	T1-T3	±5 %	50	0.75	5.0	1430	IE2-79.6	80.4	78.8	0.8	1.70	6.3	3.0	3.2	2.9	37	32	IBExU02ATEX1112/52	0.00260	17.0	
IE2-KPR 90 S4 Ex e IIC	T1-T3	±5 %	50	1.00	6.6	1440	IE2-81.0	81.1	78.7	0.78	2.3	6.8	3.1	3.5	2.9	34	30	IBExU02ATEX1113/40	0.00400	23.0	
IE2-KPR 90 L4 Ex e IIC	T1-T3	±5 %	50	1.35	8.9	1450	IE2-82.3	81.9	78.4	0.73	3.2	7.4	3.5	4.1	3.4	22	20	IBExU02ATEX1113/37	0.00450	28.0	
IE2-KPR 100 L4 Ex e IIC	T1-T3	±5 %	50	2.00	13.3	1440	IE2-83.9	84.2	82.9	0.83	4.3	6.7	2.5	3.1	2.4	30	26	IBExU02ATEX1114/37	0.00900	36.0	
IE2-KPR 100 LX4 Ex e IIC	T1-T3	±5 %	50	2.50	16.6	1440	IE2-84.8	85.5	84.7	0.83	5.3	7.3	2.7	3.5	2.5	27	24	IBExU02ATEX1114/38	0.01100	45.0	
IE2-KPER 112MZ4 Ex e IIC	T1-T3	±5 %	50	3.60	23.9	1440	IE2-86.2	86.8	85.6	0.82	7.5	7.4	2.6	3.4	2.3	18	16	IBExU02ATEX1115/29	0.0130	50.0	
IE2-K11R 132 S4 Ex e IIC	T1-T3	±10 %	40	5.0	33	1469	IE2-89.0	89.2	87.6	0.82	10.1	7.7	2.2	3.3	1.8	21	18	IBExU99ATEX1142/93	0.028	70	
IE2-K11R 132 M4 Ex e IIC	T1-T3	±10 %	55	6.8	45	1464	IE2-89.5	90.2	89.8	0.85	13.4	7.2	2.1	3.1	1.7	20	18	IBExU99ATEX1142/78	0.035	88	
IE2-K11R 160 M4 Ex e IIC	T1-T3	±10 %	40	10.0	65	1468	IE2-90.0	90.7	90.0	0.87	18.5	7.1	2.3	2.6	1.8	30	16	IBExU99ATEX1105/60	0.078	120	
IE2-K11R 160 L4 Ex e IIC	T1-T3	±10 %	40	13.5	87	1471	IE2-91.4	92.1	91.8	0.88	24	7.8	2.3	2.8	1.9	27	14	IBExU99ATEX1105/72	0.115	140	
IE2-K11R 180 M4 Ex e IIC	T1-T3	±10 %	55	15.0	97	1479	IE2-91.5	91.7	90.8	0.86	28.5	7.9	2.1	2.9	1.7	35	14	IBExU99ATEX1138/57	0.168	215	
	T1, T2	±10 %	55	17.0	111.0	1475	IE2-91.0	91.6	91.2	0.87	32.5	6.9	1.8	2.5	1.6	35					
IE2-K11R 180 L4 Ex e IIC	T1-T3	±5 %	40	17.5	112	1477	IE2-92.1	92.3	91.5	0.86	31.5	7.9	2.0	2.9	1.6	30	14	IBExU99ATEX1138/36	0.168	215	
	T1, T2	±5 %	40	20.0	129.0	1472	IE2-91.5	92.1	91.8	0.87	36	7.0	1.7	2.5	1.4	30					
IE2-K11R 200 L4 Ex e IIC	T1-T3	±10 %	50	24.0	155	1481	IE2-91.8	92.3	91.5	0.85	46	7.8	1.7	2.4	1.5	25	8	IBExU99ATEX1143/59	0.275	310	
	T1, T2	±10 %	50	27.0	175.0	1478	IE2-92.1	92.5	92.0	0.85	52	6.9	1.7	2.4	1.5	22					
IE2-K11R 225 S4 Ex e IIC	T1-T3	±5 %	40	30.0	188	1480	IE2-93.0	93.3	92.8	0.85	55	7.3	1.9	2.0	1.6	35	16	IBExU99ATEX1144/28	0.525	405	
	T1, T2	±5 %	40	33.0	208.0	1477	IE2-92.6	93.2	93.0	0.85	60	6.7	1.7	1.9	1.4	30					
IE2-K11R 225 M4 Ex e IIC	T1-T3	±5 %	40	36.0	227	1480	IE2-93.1	93.6	93.2	0.84	66	7.5	1.9	2.1	1.6	22	7	IBExU99ATEX1144/26	0.525	405	
	T1, T2	±5 %	40	40.0	253.0	1476	IE2-92.9	93.5	93.4	0.85	74	6.8	1.7	1.9	1.5	19					
IE2-K12R 225 M4 Ex e IIC	T1-T3	±10 %	40	36.0	227	1482	IE2-92.9	93.5	93.3	0.85	70	7.1	1.9	1.6	2.1	28	8	IBExU99ATEX1144/46	0.619	435	
	T1, T2	±10 %	40	40.0	253	1478	IE2-92.9	93.4	93.6	0.85	78	6.3	1.7	1.5	1.9	26					
IE2-K11R 250 M4 Ex e IIC	T1-T3	±10 %	50	44.0	277	1486	IE2-93.1	93.2	92.5	0.85	85	7.6	1.9	2.3	1.5	27	8	IBExU99ATEX1031/40	0.95	545	
	T1, T2	±10 %	50	50.0	316	1483	IE2-93.3	93.2	92.8	0.85	96	6.7	1.6	2.0	1.3	24					
IE2-K11R 280 S4 Ex e IIC	T1-T3	±10 %	50	58.0	373	1483	IE2-94.1	93.9	92.8	0.83	114	7.2	1.3	2.0	1.2	30	13	IBExU99ATEX1030/48	1.96	785	
	T1, T2	±10 %	45	68.0	437	1473	IE2-93.8	93.8	93.1	0.83	134	6.2	1.1	1.7	1.0	30					
IE2-K11R 280 M4 Ex e IIC	T1-T3	±10 %	45	70.0	448	1486	IE2-93.9	93.9	93.1	0.84	135	7.2	1.3	2.0	1.2	28	11	IBExU99ATEX1030/59	1.96	810	
	T1, T2	±10 %	40	80.0	514	1484	IE2-94.1	93.9	93.5	0.84	156	6.2	1.2	1.7	1.1	25					
IE2-K11R 315 S4 Ex e IIC	T1-T3	±5 %	40	84	538	1487	IE2-94.4	94.5	93.9	0.84	153	7.2	1.5	2.2	1.4	21	8	IBExU99ATEX1137/69	2.27	890	
	T1, T2	±5 %	40	100	641	1482	IE2-94.4	94.6	94.3	0.85	181	6.1	1.3	1.8	1.2	18					
IE2-K11R 315 M4 Ex e IIC	T1-T3		40	100	643	1485	IE2-												2.73	975	
IE2-K11R 315 MY4 Ex e IIC	T1-T3			115	738	1489	IE2-													4.82	1270
IE2-K11R 315 L4 Ex e IIC	T1-T3	±10 %	55	135	860	1491	IE2-95.1	95.3	94.8	0.86	250	7.5	1.2	2.0	0.9	29	10	IBExU99ATEX1137/81	5.93	1510	
IE2-K11R 315 LX4 Ex e IIC	T1-T3	±5 %	40	170	1085	1491	IE2-95.1	95.2	94.7	0.86	301	7.2	1.0	2.0	0.9	29	8	IBExU99ATEX1137/79	6.82	1695	
IE2-K12R 355 M4 Ex e IIC	T1-T3	±5 %	40	215	1377	1493	IE2-95.8	95.7	92.1	0.84	390	7.9	1.4	2.6	1.2	21	7	IBExU01ATEX1009/12	7.9	2150	
IE2-K12R 355 MX4 Ex e IIC	T1-T3			240	1538	1490	IE2-													9.5	2400
IE2-K12R 355 L4 Ex e IIC	T1-T3			275	1758	1494	IE2-													10	2500

Optionally in dust-protected version, protection type: Protection by enclosure "tb" to EN 60079-31
 for operation in Zone 21 (IBExU 02ATEX 1019 for series K1.R), degree of protection IP 65, double marking on rating plate.
 Other voltages and frequencies upon request. Changes are possible for motors which are not yet certified.

Three-phase motors with squirrel-cage rotor, High Efficiency IE2 Type of explosion protection – Increased safety „e“ („eb“) for operation in Zone 1 according to EN 60079-7

II 2G Ex e IIC T1/T2, T3 Gb

for rated voltage, temperature classes T1, T2 and T3
with surface cooling, duty type S1, continuous duty
thermal class F, degree of protection IP 55, 50 Hz

Motor selection data																						Design point 400 V, 50 Hz		
Type	Temperature class	Voltage tolerance	max. Coolant temperature °C	P _B	M _B	n _B	η _B			cosφ _B	I _B	I _A /I _B	M _A /M _B	M _S /M _B	M _K /M _B	t _E -time	ATEX no.	J	m					
							(IEC/EN 60034-30-1)																	
							100 %	75 %	50 %	-	A	-	-	-	-	T2	T3							
													s				kgm ²	kg						
Synchronous speed 1000 rpm – 6-pole version																								
IE2-KPR 90 L6 Ex e IIC	T1-T3	±5 %	50	0.95	9.45	960	IE2-77.3	75.8	72	0.67	2.65	5.6	3.1	3.5	2.8	46	41	IBEXU02ATEX1113/42	0.00720	30.0				
IE2-KPR 100 LX6 Ex e IIC	T1-T3	±5 %	50	1.30	12.9	960	IE2-79.0	81.1	78.2	0.72	3.20	6.0	2.4	3.2	2.4	97	87	IBEXU02ATEX1114/39	0.01390	36.0				
IE2-KPER112 MV6 Ex e IIC	T1-T3	±5 %	50	1.90	18.8	965	IE2-81.1	80.2	76.6	0.67	5.1	6.8	3.6	4.3	3.5	42	37	IBEXU02ATEX1115/28	0.01550	48.0				
IE2-K11R 132 S6 Ex e IIC	T1-T3	±10 %	40	2.60	26	959	IE2-84.4	85.3	84.6	0.83	5.6	5.7	1.8	2.8	1.3	35	30	IBEXU99ATEX1142/94	0.023	60				
IE2-K11R 132 M6 Ex e IIC	T1-T3	±10 %	50	3.50	35	952	IE2-84.9	86.2	85.7	0.83	7.1	5.8	1.7	2.8	1.1	30	27	IBEXU99ATEX1142/82	0.029	60				
IE2-K11R 132 MX6 Ex e IIC	T1-T3	±10 %	55	4.80	48	966	IE2-86.8	87.5	86.4	0.82	10.2	5.4	1.8	2.5	1.5	45	40	IBEXU99ATEX1142/76	0.053	90				
IE2-K11R 160 M6 Ex e IIC	T1-T3	±10 %	50	6.60	65	969	IE2-87.7	88.1	87.0	0.80	13.9	6.1	2.0	2.8	1.7	30	29	IBEXU99ATEX1105/91	0.0656	105				
IE2-K11R 160 L6 Ex e IIC	T1-T3	±10 %	40	9.7	96	972	IE2-88.5	88.8	87.7	0.84	19.7	5.7	2.3	2.7	2.0	60	24	IBEXU99A-TEX1105/122	0.145	145				
IE2-K11R 180 L6 Ex e IIC	T1-T3	±10 %	50	13.2	129	977	IE2-89.4	89.3	87.7	0.84	26.5	6.4	2.1	2.7	1.9	45	16	IBEXU99ATEX1138/42	0.228	190				
IE2-K11R 200 L6 Ex e IIC	T1-T3	±5 %	40	16.5	161	979	IE2-90.4	90.2	88.5	0.84	31.5	7.3	2.4	3.0	2.2	35	13	IBEXU99ATEX1143/44	0.268	200				
IE2-K11R 200 LX6 Ex e IIC	T1-T3	±10 %	40	20.0	195	980	IE2-90.6	90.6	89.4	0.86	39	6.5	2.4	2.7	1.8	40	14	IBEXU99ATEX1143/47	0.443	295				
IE2-K11R 225 M6 Ex e IIC	T1-T3	±10 %	40	27.0	262	981	IE2-91.5	91.9	91.2	0.85	50	6.5	2.7	2.6	2.0	30	9	IBEXU99ATEX1144/36	0.825	385				
IE2-K11R 250 M6 Ex e IIC	T1-T3	±10 %	40	33.0	320	983	IE2-92.0	92.1	91.4	0.86	64	6.0	2.5	2.3	1.7	29	8	IBEXU99ATEX1131/33	1.28	490				
IE2-K11R 280 S6 Ex e IIC	T1-T3	±5 %	40	40.0	386	986	IE2-92.7	92.9	92.1	0.86	72.5	7.3	2.5	2.6	2.0	25	8	IBEXU99ATEX1030/43	1.48	570				
IE2-K11R 280 M6 Ex e IIC	T1-T3	±10 %	45	46.0	436	990	IE2-92.8	93.6	93.0	0.86	87	7.3	2.0	2.6	1.6	37	15	PTB08ATEX3043/15	2.63	740				
IE2-K11R 280 M6 Ex e IIC	T1, T2	±10 %	45	50.0	478	989	IE2-93.5	93.8	93.4	0.87	94	6.7	1.8	2.4	1.5	34	15	PTB08ATEX3043/17						
IE2-K11R 315 S6 Ex e IIC	T1-T3	±5 %	40	64.0	618	989	IE2-93.6	93.7	93.5	0.88	113	7.0	1.9	2.4	1.5	30	12	IBEXU99ATEX1137/67	3.33	850				
IE2-K11R 315 S6 Ex e IIC	T1, T2	±5 %	40	68.0	657	988	IE2-93.5	93.6	93.5	0.88	120	6.6	1.8	2.2	1.4	29	12	IBEXU99ATEX1137/68						
IE2-K12R 315 S6 Ex e IIC	T1-T3	±10 %	40	64.0	613	991	IE2-93.7	93.6	93.3	0.88	118	7.4	1.6	2.5	1.4	30	12	IBEXU99ATEX1137/72	3.33	850				
IE2-K11R 315 M6 Ex e IIC	T1-T3	±10 %	40	68.0	653	989	IE2-93.8	93.5	93.3	0.89	126	6.9	1.5	2.4	1.3	30	12	IBEXU99ATEX1137/82						
IE2-K11R 315 M6 Ex e IIC	T1, T2			76.0	732	992	IE2-												3.6	1148				
IE2-K11R 315 MY6 Ex e IIC	T1, T2			82	791	990	IE2-													6	1250			
IE2-K11R 315 MY6 Ex e IIC	T1-T3			85.0	820	990	IE2-																	
IE2-K11R 315 MY6 Ex e IIC	T1, T2			92	890	987	IE2-																	
IE2-K11R 315 L6 Ex e IIC	T1-T3			95	921	985	IE2-													6.67	1250			
IE2-K11R 315 LX6 Ex e IIC	T1-T3			110	1061	990	IE2-													8.6	1460			
IE2-K11R 315 LX6 Ex e IIC	T1, T2			120	1158	990	IE2-																	
IE2-K12R 355 M6 Ex e IIC	T1-T3			125	1202	993	IE2-													8.2	1850			
IE2-K12R 355 M6 Ex e IIC	T1, T2			135	1302	990	IE2-																	
IE2-K12R 355 MX6 Ex e IIC	T1-T3			160	1539	993	IE2-													12.1	2200			
IE2-K12R 355 MX6 Ex e IIC	T1, T2			175	1688	990	IE2-																	
IE2-K12R 355 L6 Ex e IIC	T1-T3			200	1923	993	IE2-													14	2400			
IE2-K12R 355 L6 Ex e IIC	T1, T2			215	2074	990	IE2-																	
IE2-K42R 400 M6 Ex e IIC	T1-T3	±10 %	40	230	2208	995	IE2-95.1	95.2	95.1	0.84	438	7.6	1.1	2.1	1.1	11	15	IBEXU15ATEX1075/01	16.54	3000				
Synchronous speed 750 rpm – 8-pole version																								
IE2-K11R 132 S8 Ex e IIC	T1-T3			1.9	26	700														0.018	53			
IE2-K11R 132 M8 Ex e IIC	T1-T3			2.6	35	705														0.043	70			
IE2-K11R 160 M8 Ex e IIC	T1-T3			3.5	46	720														0.053	86			
IE2-K11R 160 MX8 Ex e IIC	T1-T3			4.8	64	720														0.113	114			
IE2-K11R 160 L8 Ex e IIC	T1-T3			6.6	86	730														0.145	136			
IE2-K11R 180 L8 Ex e IIC	T1-T3			9.7	128	725														0.228	175			
IE2-K11R 200 L8 Ex e IIC	T1-T3	±10 %	55	13.2	173	730	IE2-89.1	89.4	88.5	0.77	29	5.2	2.0	2.4	1.6	50	16	IBEXU99ATEX1143/66	0.268	230				
IE2-K11R 225 S8 Ex e IIC	T1-T3			16.5	216	730														0.44	265			
IE2-K11R 225 M8 Ex e IIC	T1-T3			20.0	260	735														0.825	360			
IE2-K11R 250 M8 Ex e IIC	T1-T3			27.0	350	737														1.35	465			
IE2-K11R 280 S8 Ex e IIC	T1-T3	±10 %	40	33.0	425	738	IE2-92.2	92.3	91.2	0.79	68	5.9	2.3	2.4	1.8	12	35	IBEXU99ATEX1030/63	1.55	570				
IE2-K11R 280 M8 Ex e IIC	T1-T3			40.0	516	740														2.63	690			
IE2-K11R 315 S8 Ex e IIC	T1-T3			50	645	740														3.33	800			
IE2-K11R 315 M8 Ex e IIC	T1-T3			68	878	740														3.33	800			
IE2-K11R 315 MY8 Ex e IIC	T1-T3			80	1030	742														6	1050			
IE2-K11R 315 L8 Ex e IIC	T1-T3			95	1221	743														6.76	1250			
IE2-K11R 315 LX8 Ex e IIC	T1-T3			115	1484	740														8.71	1430			
IE2-K12R 355 M8 Ex e IIC	T1-T3			140	1807	740														9.5	1850			
IE2-K12R 355 MX8 Ex e IIC	T1-T3			180	2323	740														13.4	2200			
IE2-K12R 355 L8 Ex e IIC	T1-T3			210	2710	740														15.8	2400			

Optionally in dust-protected version, protection type: Protection by enclosure "tb" to EN 60079-31
for operation in Zone 21 (IBEXU 02ATEX 1019 for series K1.R), degree of protection IP 65, double marking on rating plate.
Other voltages and frequencies upon request. Changes are possible for motors which are not yet certified.

Three-phase motors with squirrel-cage rotor, High Efficiency IE2

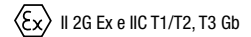

Type of explosion protection – Increased safety „e“ („eb“)

for operation in Zone 1 according to EN 60079-7

according to VIK Recommendation 1, Three-Phase Asynchronous Motors – Technical Requirements 03.2011

for rated voltage, temperature classes T1, T2 and T3

with surface cooling, duty type S1, continuous duty

thermal class F, degree of protection IP 55, 50 Hz

Motor selection data table with columns: Type, Temperature class, Voltage tolerance, max. Coolant temperature, P_B, M_B, n_B, η_B, cosφ_B, I_B, I_A/I_B, M_A/M_B, M_S/M_B, M_K/M_B, t_E-time, ATEX no., J, m. Includes sub-section for Synchronous speed 3000 rpm – 2-pole version.

Optionally in dust-protected version, protection type: Protection by enclosure "tb" to EN 60079-31 for operation in Zone 21 (IBExU 02ATEX 1019 for series K1.R), degree of protection IP 65, double marking on rating plate. Other voltages and frequencies upon request. Changes are possible for motors which are not yet certified.

Three-phase motors with squirrel-cage rotor, High Efficiency IE2

II 2G Ex e IIC T1/T2, T3 Gb

Type of explosion protection – Increased safety „e“ („eb“)

for operation in Zone 1 according to EN 60079-7

according to VIK Recommendation 1, Three-Phase Asynchronous Motors – Technical Requirements 03.2011

for rated voltage, temperature classes T1, T2 and T3
with surface cooling, duty type S1, continuous duty
thermal class F, degree of protection IP 55, 50 Hz

Motor selection data														Design point 400 V, 50 Hz						
Type	Temperature class	Voltage tolerance	max. Coolant temperature °C	P _B kW	M _B Nm	n _B rpm	η _B (IEC/EN 60034-30-1)			cosφ _B	I _B 400 V A	I _A /I _B	M _A /M _B	M _S /M _B	M _K /M _B	t _E -time		ATEX no.	J kgm ²	m kg
							100 %	75 %	50 %	-						T2	T3			
Synchronous speed 3000 rpm – 2-pole version																				
IE2-K11R 315 S2 Ex e IIC	T1-T3	±5 %	55	68	216	2975	IE2-94.2	94.3	93.7	0.89	118	7.7	1.3	2.1	1.2	24	9	IBEXU99ATEX1137/74	1.44	850
IE2-K11R 315 S2G Ex e IIC	T1-T3	±5 %		68	216	2975	IE2-94.2	94.3	93.7	0.89	118	7.7	1.3	2.1	1.2	-	-		1.44	850
IE2-K11R 315 M2 Ex e IIC	T1-T3	±5 %	50	80	255	2973	IE2-93.9	93.7	92.7	0.89	138	7.4	1.2	1.8	1.0	23	8	IBEXU99ATEX1137/76	1.76	970
IE2-K11R 315 M2G Ex e IIC	T1-T3	±5 %		80	255	2973	IE2-93.9	93.7	92.7	0.89	138	7.4	1.2	1.8	1.0	-	-		1.76	970
IE2-K11R 315 MY2 Ex e IIC	T1-T3	±5 %	40	110	349	2980	IE2-95.1	95.2	94.8	0.93	180	6.9	1.0	2.4	0.7	35	11	IBEXU99ATEX1137/64	2.82	1270
IE2-K11R 315 MY2G Ex e IIC	T1-T3	±5 %		110	349	2980	IE2-95.1	95.2	94.8	0.93	180	6.9	1.0	2.4	0.7	-	-		2.82	1200
IE2-K11R 315 L2 Ex e IIC	T1-T3			125	401	2980	IE2-												3.66	1450
IE2-K11R 315 L2G Ex e IIC	T1-T3			125	401	2980	IE2-												3.66	1450
IE2-K11R 315 LX2 Ex e IIC	T1-T3			150	480	2985	IE2-												4.43	1630
IE2-K11R 315 LX2G Ex e IIC	T1-T3			150	480	2985	IE2-												4.43	1630
IE2-K12R 355 M2 Ex e IIC	T1-T3			190	609	2980	IE2-												4.2	2000
IE2-K12R 355 MX2 Ex e IIC	T1-T3			220	705	2980	IE2-												4.5	2200
IE2-K12R 355 L2 Ex e IIC	T1-T3			250	801	2980	IE2-												7.1	2400

Optionally in dust-protected version, protection type: Protection by enclosure "tb" to EN 60079-31
for operation in Zone 21 (IBEXU 02ATEX 1019 for series K1.R), degree of protection IP 65, double marking on rating plate.
Other voltages and frequencies upon request. Changes are possible for motors which are not yet certified.

Three-phase motors with squirrel-cage rotor, High Efficiency IE2

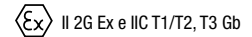

Type of explosion protection – Increased safety „e“ („eb“)

for operation in Zone 1 according to EN 60079-7

according to VIK Recommendation 1, Three-Phase Asynchronous Motors – Technical Requirements 03.2011

for rated voltage, temperature classes T1, T2 and T3

with surface cooling, duty type S1, continuous duty

thermal class F, degree of protection IP 55, 50 Hz

Motor selection data																	Design point 400 V, 50 Hz			
Type	Temperature class	Voltage tolerance	max. Coolant temperature °C	P _B kW	M _B Nm	n _B rpm	η _B (IEC/EN 60034-30-1)			cosφ _B	I _B A	I _A /I _B	M _A /M _B	M _S /M _B	M _K /M _B	t _E -time		ATEX no.	J kgm ²	m kg
							100 %	75 %	50 %							T2	T3			
Synchronous speed 1500 rpm – 4-pole version																				
IE2-KPR 80 G4 Ex e IIC	T1-T3	±5 %	50	0.75	5.0	1430	IE2-79.6	80.4	78.8	0.8	1.70	6.3	3.0	3.2	2.9	37	32	IBExU02ATEX1112	0.00260	17.0
IE2-KPR 90 S4 Ex e IIC	T1-T3	±5 %	50	1.00	6.6	1440	IE2-81.0	81.1	78.7	0.78	2.3	6.8	3.1	3.5	2.9	34	30	IBExU02ATEX1113	0.00400	23.0
IE2-KPR 90 L4 Ex e IIC	T1-T3	±5 %	50	1.35	8.9	1450	IE2-82.3	81.9	78.4	0.73	3.2	7.4	3.5	4.1	3.4	22	20	IBExU02ATEX1113	0.00450	28.0
IE2-KPR 100 L4 Ex e IIC	T1-T3	±5 %	50	2.00	13.3	1440	IE2-83.9	84.2	82.9	0.83	4.3	6.7	2.5	3.1	2.4	30	26	IBExU02ATEX1114	0.00900	36.0
IE2-KPR 100 LX4 Ex e IIC	T1-T3	±5 %	50	2.50	16.6	1440	IE2-84.8	85.5	84.7	0.83	5.3	7.3	2.7	3.5	2.5	27	24	IBExU02ATEX1114	0.01100	45.0
IE2-KPER 112 MZ4 Ex e IIC	T1-T3	±5 %	50	3.60	23.9	1440	IE2-86.2	86.8	85.6	0.82	7.5	7.4	2.6	3.4	2.3	18	16	IBExU02ATEX1115	0.0130	50.0
IE2-K11R 132 S4 Ex e IIC	T1-T3	±10 %	40	5.0	33	1469	IE2-89.0	89.2	87.6	0.82	10.1	7.7	2.2	3.3	1.8	21	18	IBExU99ATEX1142/93	0.028	70
IE2-K11R 132 M4 Ex e IIC	T1-T3	±10 %	55	6.8	45	1464	IE2-89.5	90.2	89.8	0.85	13.4	7.2	2.1	3.1	1.7	20	18	IBExU99ATEX1142/78	0.035	88
IE2-K11R 160 M4 Ex e IIC	T1-T3	±10 %	40	10.0	65	1468	IE2-90.0	90.7	90.0	0.87	19.4	6.8	2.3	2.6	1.8	30	16	IBExU99ATEX1105/120	0.078	120
IE2-K11R 160 L4 Ex e IIC	T1-T3	±10 %	40	13.5	87	1471	IE2-91.4	92.1	91.8	0.88	24	7.3	2.3	2.8	1.9	26	13	IBExU99ATEX1105/121	0.115	140
IE2-K11R 180 M4 Ex e IIC	T1-T3	±10 %	55	15.0	97	1479	IE2-91.5	91.7	90.8	0.86	28.5	7.9	2.1	2.9	1.7	35	14	IBExU99ATEX1138/57	0.168	215
IE2-K11R 180 L4 Ex e IIC	T1-T3	±10 %	55	17.5	112	1478	IE2-91.9	92.1	91.2	0.85	33.5	7.6	2.0	2.9	1.6	30	10	IBExU99ATEX1138/59	0.168	215
IE2-K11R 200 L4 Ex e IIC	T1-T3	±10 %	50	24.0	155	1481	IE2-91.8	92.3	91.5	0.85	46	7.8	1.7	2.4	1.5	25	8	IBExU99ATEX1143/59	0.275	310
IE2-K11R 225 S4 Ex e IIC	T1-T3	±5 %	40	30.0	188	1480	IE2-93.0	93.3	92.8	0.85	55	7.3	1.9	2.0	1.6	35	16	IBExU99ATEX1144/28	0.525	405
IE2-K11R 225 M4 Ex e IIC	T1-T3	±5 %	40	36.0	227	1480	IE2-93.1	93.6	93.2	0.84	66	7.5	1.9	2.1	1.6	22	7	IBExU99ATEX1144/26	0.525	405
IE2-K12R 225 M4 Ex e IIC	T1-T3	±10 %	40	40.0	253	1476	IE2-92.9	93.5	93.4	0.85	74	6.8	1.7	1.9	1.5	19		IBExU99ATEX1144/27		
IE2-K11R 250 M4 Ex e IIC	T1-T3	±10 %	50	44.0	277	1486	IE2-93.1	93.2	92.5	0.85	85	7.6	1.9	2.3	1.5	27	8	IBExU99ATEX1031/40	0.95	545
IE2-K11R 280 S4 Ex e IIC	T1-T3	±10 %	50	50.0	316	1483	IE2-93.3	93.2	92.8	0.85	96	6.7	1.6	2.0	1.3	24		IBExU99ATEX1131/41		
IE2-K11R 280 M4 Ex e IIC	T1-T3	±10 %	45	68.0	437	1473	IE2-93.8	93.8	93.1	0.83	134	6.2	1.1	1.7	1.0	30		IBExU99ATEX1030/49		
IE2-K11R 315 S4 Ex e IIC	T1-T3	±5 %	40	84	538	1487	IE2-94.4	94.5	93.9	0.84	153	7.2	1.5	2.2	1.4	21	8	IBExU99ATEX1137/69	2.27	890
IE2-K11R 315 M4 Ex e IIC	T1-T3	±5 %	40	100.0	641	1482	IE2-94.4	94.6	94.3	0.85	181	6.1	1.3	1.8	1.2	18		IBExU99ATEX1137/71		
IE2-K11R 315 MY4 Ex e IIC	T1-T3			115	738	1489	IE2-												2.73	975
IE2-K11R 315 L4 Ex e IIC	T1-T3	±10 %	55	135	860	1491	IE2-95.1	95.3	94.8	0.86	250	7.5	1.2	2.0	0.9	29	10	IBExU99ATEX1137/81	5.93	1510
IE2-K11R 315 LX4 Ex e IIC	T1-T3	±5 %	40	170	1085	1491	IE2-95.1	95.2	94.7	0.86	301	7.2	1.0	2.0	0.9	29	8	IBExU99ATEX1137/79	6.82	1695
IE2-K12R 355 M4 Ex e IIC	T1-T3	±5 %	40	215	1377	1493	IE2-95.8	95.7	92.1	0.84	390	7.9	1.4	2.6	1.2	21	7	IBExU01ATEX1009/12	7.9	2150
IE2-K12R 355 MX4 Ex e IIC	T1-T3			240	1538	1490	IE2-												9.5	2400
IE2-K12R 355 L4 Ex e IIC	T1-T3			275	1758	1494	IE2-												10	2500

Optionally in dust-protected version, protection type: Protection by enclosure "tb" to EN 60079-31 for operation in Zone 21 (IBExU 02ATEX 1019 for series K1.R), degree of protection IP 65, double marking on rating plate. Other voltages and frequencies upon request. Changes are possible for motors which are not yet certified.



IE2 II 2G Ex e IIC T1/T2, T3 Gb

Three-phase motors with squirrel-cage rotor, High Efficiency IE2

Type of explosion protection – Increased safety „e“ („eb“)

for operation in Zone 1 according to EN 60079-7

according to VIK Recommendation 1, Three-Phase Asynchronous Motors – Technical Requirements 03.2011

for rated voltage, temperature classes T1, T2 and T3

with surface cooling, duty type S1, continuous duty

thermal class F, degree of protection IP 55, 50 Hz

Motor selection data																		Design point 400 V, 50 Hz			
Type	Temperature class	Voltage tolerance	max. Coolant temperature °C	P _B kW	M _B Nm	n _B rpm	η _B (IEC/EN 60034-30-1)			cosφ _B	I _B 400 V A	I _A /I _B	M _A /M _B	M _S /M _B	M _K /M _B	t _E -time		ATEX no.	J kgm ²	m kg	
							100%	75%	50%							T2 s	T3 s				
Synchronous speed 1000 rpm – 6-pole version																					
IE2-KPR 90 L6 Ex e IIC	T1-T3	±5 %	50	0.95	9.45	960	IE2- 77.3	75.8	72	0.67	2.65	5.6	3.1	3.5	2.8	46	41	IBEXU02ATEX1113	0.00720	30.0	
IE2-KPR 100 LX6 Ex e IIC	T1-T3	±5 %	50	1.30	12.9	960	IE2- 79.0	81.1	78.2	0.72	3.20	6.0	2.4	3.2	2.4	97	87	IBEXU02ATEX1114	0.01390	36.0	
IE2-KPER 112 MV6 Ex e IIC	T1-T3	±5 %	50	1.90	18.8	965	IE2- 81.1	80.2	76.6	0.67	5.1	6.8	3.6	4.3	3.5	42	37	IBEXU02ATEX1115	0.01550	48.0	
IE2-K11R 132 S6 Ex e IIC	T1-T3	±10 %	40	2.60	26	959	IE2- 84.4	85.3	84.6	0.83	5.6	5.7	1.8	2.8	1.3	35	30	IBEXU99ATEX1142/94	0.023	60	
IE2-K11R 132 M6 Ex e IIC	T1-T3	±10 %	50	3.50	35	952	IE2- 84.9	86.2	85.7	0.83	7.1	5.8	1.7	2.8	1.1	30	27	IBEXU99ATEX1142/82	0.029	60	
IE2-K11R 132 MX6 Ex e IIC	T1-T3	±10 %	55	4.80	48	966	IE2- 86.8	87.5	86.4	0.82	10.2	5.4	1.8	2.5	1.5	45	40	IBEXU99ATEX1142/76	0.053	90	
IE2-K11R 160 M6 Ex e IIC	T1-T3	±10 %	50	6.60	65	969	IE2- 87.7	88.1	87.0	0.80	13.9	6.1	2.0	2.8	1.7	30	29	IBEXU99ATEX1105/91	0.0656	105	
IE2-K11R 160 L6 Ex e IIC	T1-T3	±10 %	40	9.7	96	972	IE2- 88.5	88.8	87.7	0.84	19.7	5.7	2.3	2.7	2.0	60	24	IBEXU99ATEX1105/122	0.145	145	
IE2-K11R 180 L6 Ex e IIC	T1-T3	±10 %	50	13.2	129	977	IE2- 89.4	89.3	87.7	0.84	26.5	6.4	2.1	2.7	1.9	45	16	IBEXU99ATEX1138/42	0.228	190	
IE2-K11R 200 L6 Ex e IIC	T1-T3	±5 %	40	16.5	161	979	IE2- 90.4	90.2	88.5	0.84	31.5	7.3	2.4	3.0	2.2	35	13	IBEXU99ATEX1143/44	0.268	200	
IE2-K11R 200 LX6 Ex e IIC	T1-T3	±10 %	40	20.0	195	980	IE2- 90.6	90.6	89.4	0.86	39	6.5	2.4	2.7	1.8	40	14	IBEXU99ATEX1143/47	0.443	295	
IE2-K11R 225 M6 Ex e IIC	T1-T3	±10 %	40	27.0	262	981	IE2- 91.5	91.9	91.2	0.85	50	6.5	2.7	2.6	2.0	30	9	IBEXU99ATEX1144/36	0.825	385	
IE2-K11R 250 M6 Ex e IIC	T1-T3	±10 %	40	33.0	320	983	IE2- 92.0	92.1	91.4	0.86	64	6.0	2.5	2.3	1.7	29	8	IBEXU99ATEX1131/33	1.28	490	
IE2-K11R 280 S6 Ex e IIC	T1-T3	±5 %	40	40.0	386	986	IE2- 92.7	92.9	92.1	0.86	72.5	7.3	2.5	2.6	2.0	25	8	IBEXU99ATEX1030/43	1.48	570	
IE2-K11R 280 M6 Ex e IIC	T1-T3	±10 %	45	46.0	436	989	IE2- 92.8	93.6	93.0	0.86	87	7.3	2.0	2.6	1.6	37	15	PTB08ATEX3043/15	2.63	740	
	T1,T2	±10 %	45	50.0	478	989	IE2- 93.5	93.8	93.4	0.87	94	6.7	1.8	2.4	1.5	34		PTB08ATEX3043/17			
IE2-K11R 315 S6 Ex e IIC	T1-T3	±5 %	40	64.0	618	989	IE2- 93.6	93.7	93.5	0.88	113	7.0	1.9	2.4	1.5	30	12	IBEXU99ATEX1137/67	3.33	850	
	T1,T2	±5 %	40	68.0	657	988	IE2- 93.5	93.6	93.5	0.88	120	6.6	1.8	2.2	1.4	29		IBEXU99ATEX1137/68			
IE2-K12R 315 S6 Ex e IIC	T1-T3	±10 %	40	64.0	613	991	IE2- 93.7	93.6	93.3	0.88	118	7.4	1.6	2.5	1.4	30	12	IBEXU99ATEX1137/72	3.33	850	
	T1,T2	±10 %	40	68.0	653	989	IE2- 93.8	93.5	93.3	0.89	126	6.9	1.5	2.4	1.3	30		IBEXU99ATEX1137/82			
IE2-K11R 315 M6 Ex e IIC	T1-T3			76.0	732	992	IE2-									-	-		3.6	1148	
IE2-K11R 315 MY6 Ex e IIC	T1-T3			85.0	820	990	IE2-									-	-		6	1250	
IE2-K11R 315 L6 Ex e IIC	T1-T3			95	921	985	IE2-									-	-		6.67	1250	
IE2-K11R 315 LX6 Ex e IIC	T1-T3			110	1061	990	IE2-									-	-		8.6	1460	
IE2-K12R 355 M6 Ex e IIC	T1-T3			125	1202	993	IE2-									-	-		8.2	1850	
IE2-K12R 355 MX6 Ex e IIC	T1-T3			160	1539	993	IE2-									-	-		12.1	2200	
IE2-K12R 355 L6 Ex e IIC	T1-T3			200	1923	993	IE2-									-	-		14	2400	
IE2-K42R 400 M6 Ex e IIC	T1-T3	±10 %	40	230	2208	995	IE2- 95.1	95.2	95.1	0.8	438.0	7.6	1.1	2	1	11	15	IBEXU15ATEX1075/01	16.54	3000	
Synchronous speed 750 rpm – 8-pole version																					
IE2-K11R 132 S8 Ex e IIC	T1-T3			1.9	26	700										-	-		0.018	53	
IE2-K11R 132 M8 Ex e IIC	T1-T3			2.6	35	705										-	-		0.043	70	
IE2-K11R 160 M8 Ex e IIC	T1-T3			3.5	46	720										-	-		0.053	86	
IE2-K11R 160 MX8 Ex e IIC	T1-T3			4.8	64	720										-	-		0.113	114	
IE2-K11R 160 L8 Ex e IIC	T1-T3			6.6	86	730										-	-		0.145	136	
IE2-K11R 180 L8 Ex e IIC	T1-T3			9.7	128	725										-	-		0.228	175	
IE2-K11R 200 L8 Ex e IIC	T1-T3	±10 %	55	13.2	173	730	IE2- 89.1	89.4	88.5	0.77	29	5.2	2.0	2.4	1.6	50	16	IBEXU99ATEX1143/66	0.268	230	
IE2-K11R 225 S8 Ex e IIC	T1-T3			16.5	216	730										-	-		0.44	265	
IE2-K11R 225 M8 Ex e IIC	T1-T3			20.0	260	735										-	-		0.825	360	
IE2-K11R 250 M8 Ex e IIC	T1-T3			27.0	350	737										-	-		1.35	465	
IE2-K11R 280 S8 Ex e IIC	T1-T3	±10 %	40	33.0	425	738	IE2- 92.2	92.3	91.2	0.79	68	5.9	2.3	2.4	1.8	12	35	IBEXU99ATEX1030/63	1.55	570	
IE2-K11R 280 M8 Ex e IIC	T1-T3			40.0	516	740										-	-		2.63	690	
IE2-K11R 315 S8 Ex e IIC	T1-T3			50	645	740										-	-		3.33	800	
IE2-K11R 315 M8 Ex e IIC	T1-T3			68	878	740										-	-		3.33	800	
IE2-K11R 315 MY8 Ex e IIC	T1-T3			80	1030	742										-	-		6	1050	
IE2-K11R 315 L8 Ex e IIC	T1-T3			95	1221	743										-	-		6.76	1250	
IE2-K11R 315 LX8 Ex e IIC	T1-T3			115	1484	740										-	-		8.71	1430	
IE2-K12R 355 M8 Ex e IIC	T1-T3			140	1807	740										-	-		9.5	1850	
IE2-K12R 355 MX8 Ex e IIC	T1-T3			180	2323	740										-	-		13.4	2200	
IE2-K12R 355 L8 Ex e IIC	T1-T3			210	2710	740										-	-		15.8	2400	

Optionally in dust-protected version, protection type: Protection by enclosure "tb" to EN 60079-31 for operation in Zone 21 (IBEXU 02ATEX 1019 for series K1.R), degree of protection IP 65, double marking on rating plate. Other voltages and frequencies upon request. Changes are possible for motors which are not yet certified.

Three-phase motors with squirrel-cage rotor Type of explosion protection – Increased safety „e“ („eb“) for operation in Zone 1 according to EN 60079-7

for rated voltage, temperature classes T1, T2 and T3
with surface cooling, duty type S1, continuous duty
thermal class F, degree of protection IP 55, 50 Hz

Motor selection data														Design point 400 V, 50 Hz				
Type	Temperature class	P _B kW	M _B Nm	n _B rpm	η _B (IEC/EN 60034-2)			cos φ _B -	I _B 400 V A	I _A /I _B -	M _R /M _B -	M _S /M _B -	M _K /M _B -	t _E -time		ATEX no.	J kgm ²	m kg
					100 %	75 %	50 %							T2 s	T3 s			
Synchronous speed 3000 rpm – 2-pole version																		
K11R 280 S2 Ex e IIC	T1-T3	47	151	2970	93.7	93.5	92.0	0.88	82	7.1	1.4	1.3	2.2	50	25	PTB08ATEX3043/03	1.210	730
	T1,T2	68	219	2960														
K11R 280 S2 Ex e IIC	T1-T3	68	218	2975	93.7	92.5	90.0	0.89	117	7.8	1.4	1.3	2.3	9	23	IBExU99ATEX1030/14	1.210	730
	T1,T2	68	218	2975	93.7	92.5	90.0	0.89	117	7.8	1.4	1.3	2.3	23		IBExU99ATEX1030/14		
K11R 280 S2G Ex e IIC	T1-T3	47	151	2976	94.5	93.8	92.5	0.89	81	8.0	1.4	1.1	2.1	35	18	IBExU99ATEX1030/23	1.210	730
	T1,T2	68	219	2970														
K11R 280 M2 Ex e IIC	T1-T3	58	186	2975	94.1	93.0	91.0	0.88	101	7.1	1.4	1.3	2.1	40	18	PTB08ATEX3043/04	1.440	815
	T1,T2	76	244	2970	94.5			0.90	130	6.6	1.1	1.0	1.7	30		PTB08ATEX3043/05		
K11R 280 M2G Ex e IIC	T1-T3	58	186	2970	94.7	94.6	93.0	0.90	98	7.3	1.1	1.0	2.1	45	21	IBExU99ATEX1030/24	1.440	815
	T1,T2	76	244	2970	94.5			0.90	130	6.6	1.1	1.0	1.7					
K11R 315 S2 Ex e IIC	T1-T3	68	218	2975	95.0	94.5	93.5	0.90	116	7.5	1.8	1.6	2.3	28	11	PTB08ATEX3044/02	1.44	850
	T1,T2	95	307	2960	94.5			0.89	162	5.8	1.4	1.3	1.8	18		IBExU99ATEX1137/02		
K11R 315 S2G Ex e IIC	T1-T3	68	218	2974	94.3	93.5	92.0	0.90	116	7.8	1.5	1.3	2.1	24	9	IBExU99ATEX1137/39	1.44	850
	T1,T2	95	307	2960	94.5			0.89	162	5.8	1.4	1.3	1.8					
K11R 315 M2 Ex e IIC	T1-T3	80	257	2975	95.3	94.7	94.0	0.90	134	7.5	1.8	1.6	2.2	29	12	PTB08ATEX3044/03	1.76	970
	T1,T2	112	361	2960	95.0			0.89	191	7.5	1.2	1.2	2.1					
K11R 315 M2G Ex e IIC	T1-T3	80	257	2975	95.3	95.0	94.0	0.90	135	7.1	1.3	1.2	2.3	35	15	IBExU99ATEX1137/56	1.76	970
	T1,T2	112	362	2958	94.7			0.89	154	7.0	0.9	0.8	1.7					
K11R 315 MY2 Ex e IIC	T1-T3	110	354	2970	95.0	94.5	93.5	0.92	182	7.3	1.5	1.3	3.0	26	11	PTB08ATEX3044/04	2.82	1150
	T1,T2	110	354	2970	95.0	94.5	93.5	0.92	182	7.3	1.5	1.3	3.0	26				
K11R 315 MY2G Ex e IIC	T1-T3	110	354	2970	95.2	95.0	93.0	0.93	180	6.5	1.3	1.2	2.7	30	11	IBExU99ATEX1137/41	2.82	1150
	T1,T2	110	354	2970	95.0	94.5	93.5	0.92	182	7.3	1.5	1.3	3.0					
K11R 315 L2 Ex e IIC	T1-T3	125	401	2980	95.3	95.0	93.5	0.93	205	8.0	1.5	1.3	2.8	30	12	IBExU99ATEX1137/40	3.66	1460
	T1,T2	165	528	2985														
K11R 315 L2G Ex e IIC	T1-T3	125	401	2980	95.3	95.0	93.5	0.93	205	8.0	1.5	1.3	2.8				3.66	1460
	T1,T2	165	528	2985														
K11R 315 LX2 Ex e IIC	T1-T3	150	480	2985	95.8	95.4	93.5	0.95	240	8.0	1.1	0.9	2.7	30	12	IBExU99ATEX1137/30	4.43	1630
	T1,T2	200	640	2985														
K11R 315 LX2G Ex e IIC	T1-T3	150	480	2985	95.8	95.4	93.5	0.95	240	8.0	1.1	0.9	2.7				4.43	1630
	T1,T2	200	640	2985														
K12R 355 M2 Ex e IIC	T1-T3	190	609	2980	95.0			0.91	310	8.0	1.4	1.1	2.6				4.20	2000
	T1,T2	220	706	2974										8		IBEXU01ATX1009/05		
K12R 355 MX2 Ex e IIC	T1-T3	220	705	2980	95.0			0.91	360	8.0	1.4	1.1	2.6				5.50	2200
	T1,T2	250	800	2985														
K12R 355 L2 Ex e IIC	T1-T3	250	796	2986	95.1	95.5	95.2	0.93	406	6.4	1.3	0.7	1.9	9	6	IBEXU01ATX1009/17	9.50	2400
	T1,T2	300	960	2985										17		IBEXU01ATX1009/06		

Optionally in dust-protected version, protection type: Protection by enclosure "tb" to EN 60079-31
for operation in Zone 21 (IBEXU 02ATEX 1019 for series K1.R), degree of protection IP 65, double marking on rating plate.
Other voltages and frequencies upon request. Changes are possible for motors which are not yet certified.

Three-phase motors with squirrel-cage rotor
Type of explosion protection – Increased safety „e“ („eb“)
for operation in Zone 1 according to EN 60079-7

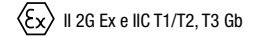

for rated voltage, temperature classes T1, T2 and T3
 with surface cooling, duty type S1, continuous duty
 thermal class F, degree of protection IP 55, 50 Hz

Motor selection data														Design point 400 V, 50 Hz						
Type	Temperature class	P _B kW	M _B Nm	n _B rpm	η _B			cosφ _B -	I _B A	I _A /I _B -	M _A /M _B -	M _S /M _B -	M _K /M _B -	t _e -time		ATEX no.	J kgm ²	m kg		
					(IEC/EN 60034-2)									400 V					T2	T3
					100%	75%	50%							-	-				s	s
Synchronous speed 1500 rpm – 4-pole version																				
KPER 63 K4 Ex e IIC	T1-T3	0.12	0.85	1370	56	56	46	0.68	0.48	2.9	1.8	1.8	2.2	70	50	IBExU02ATEX1110	0.00019	4.8		
KPER 63 G4 Ex e IIC	T1-T3	0.18	1.25	1360	60	59	52	0.69	0.63	3.2	1.9	1.9	2.2	35	30	IBExU02ATEX1110	0.00024	5.2		
KPER 71 K4 Ex e IIC	T1-T3	0.25	1.75	1380	65	63	58	0.73	0.79	3.4	1.4	1.4	1.8	27	24	IBExU02ATEX1111	0.00040	6.8		
KPER 71 G4 Ex e IIC	T1-T3	0.37	2.6	1370	67	67	64	0.75	1.08	3.6	1.6	1.6	2.0	21	18	IBExU02ATEX1111	0.00050	7.8		
KPER 80 K4 Ex e IIC	T1-T3	0.55	3.8	1380	69	71	67	0.76	1.59	3.9	1.8	1.8	2.0	16	13	IBExU02ATEX1112	0.00087	10.6		
KPER 80 G4 Ex e IIC	T1-T3	0.75	5.15	1390	72	73	70	0.74	2.0	4.4	2.0	2.0	2.3	17	14	IBExU02ATEX1112	0.00107	11.7		
KPER 90 S4 Ex e IIC	T1-T3	1.0	6.75	1410	77	78	75	0.80	2.4	5.1	2.4	2.3	2.5	19	17	IBExU02ATEX1113	0.00207	15.5		
KPER 90 L4 Ex e IIC	T1-T3	1.35	9.15	1410	79	80	79	0.81	3.1	5.5	2.3	1.8	2.5	14	12	IBExU02ATEX1113	0.00260	18.0		
KPER 100 L4 Ex e IIC	T1-T3	2.0	13.5	1420	80	82	80	0.80	4.65	6.0	2.8	2.6	2.9	13	11	IBExU02ATEX1114	0.00400	23.5		
KPER 100 LX4 Ex e IIC	T1-T3	2.5	16.6	1440	83	83	81	0.78	5.6	6.7	2.3	2.2	2.9	12	11	IBExU02ATEX1114	0.00725	30.0		
KPER 112 M4 Ex e IIC	T1-T3	3.6	23.9	1440	85	85	84	0.77	8.1	7.0	2.8	2.1	2.9	9	7	IBExU02ATEX1115	0.0090	37.0		
K11R 132 S4 Ex e IIC	T1-T3	5.0	33	1435	84.5	84.0	83.0	0.83	10.2	6.5	2.0	1.6	2.8	15	10	PTB08ATEX3037/11	0.0150	53		
K11R 132 M4 Ex e IIC	T1-T3	6.8	45	1455	87.5	87.0	86.0	0.82	13.6	6.1	2.1	1.8	2.7	29	12	PTB08ATEX3037/12	0.028	72		
K11R 160 M4 Ex e IIC	T1-T3	10	65	1465	91.0	90.5	89.5	0.89	18	6.3	2.0	1.7	2.5	40	18	PTB08ATEX3038/17	0.078	123		
K11R 160 L4 Ex e IIC	T1-T3	13.5	88	1470	90.5	90.0	88.0	0.86	25	7.7	2.5	2.0	3.0	26	9	PTB08ATEX3038/18	0.090	136		
K11R 180 M4 Ex e IIC	T1-T3	15	97	1475	90.5	90.0	88.0	0.87	27.5	6.8	1.9	1.6	2.5	45	15	PTB08ATEX3039/08	0.138	180		
	T1,T2	17	111.0	1465	90.5			0.88	31	6.0	1.7	1.4	2.3	35		PTB08ATEX3039/09				
K11R 180 L4 Ex e IIC	T1-T3	17.5	113	1475	90.5	90.0	88.0	0.85	33	7.1	2.1	1.8	2.8	25	9	PTB08ATEX3039/10	0.138	185		
	T1,T2	20	130.0	1470	90.5			0.86	37	6.3	1.8	1.6	2.4	24		PTB08ATEX3039/11				
K11R 200 L4 Ex e IIC	T1-T3	24	155	1477	92.7	92.5	91.0	0.87	43	6.8	1.8	1.5	2.4	35	12	PTB08ATEX3040/09	0.275	270		
	T1,T2	27	175.0	1470	92.5			0.88	48	6.0	1.6	1.5	2.2	30		PTB08ATEX3040/10				
K11R 225 S4 Ex e IIC	T1-T3	30	194	1475	93.0	92.5	92.0	0.85	55	6.1	1.6	1.4	1.9	30	14	PTB08ATEX3041/07	0.525	380		
	T1,T2	33	214.0	1472	92.9			0.85	60	5.6	1.5	1.2	1.7	30		PTB08ATEX3041/08				
K12R 225 S4 Ex e IIC	T1-T3	30	194	1482	92.8	93.3	92.8	0.84	58	7.1	1.9	2.1	1.6	29	9	IBExU02ATEX1144/41	0.525	380		
	T1,T2	33	214.0	1479	92.5	93.2	93.0	0.85	64	6.4	1.7	1.9	1.5	27		IBExU02ATEX1144/42				
K11R 225 M4 Ex e IIC	T1-T3	36	232	1480	94.0	93.5	92.5	0.85	65	7.4	2.2	1.7	2.3	22	7	PTB08ATEX3041/09	0.525	385		
	T1,T2	40	259.0	1475	93.5			0.85	73	6.6	2.0	1.6	2.1	19		PTB08ATEX3041/10				
K11R 250 M4 Ex e IIC	T1-T3	44	283	1485	94.0	93.5	92.5	0.86	79	7.2	1.8	1.6	2.1	30	10	PTB08ATEX3042/05	0.95	530		
	T1,T2	50	323.0	1480	94.0			0.86	90	6.3	1.7	1.5	1.9	27		PTB08ATEX3042/06				
K11R 280 S4 Ex e IIC	T1-T3	58	373	1485	94.2	93.7	92.5	0.84	106	7.2	1.8	1.6	2.2	40	13	PTB08ATEX3043/06	1.96	765		
	T1,T2	68	439.0	1480	94.0			0.85	124	6.1	1.6	1.4	1.9	30		IBExU02ATEX1030/02				
K11R 280 M4 Ex e IIC	T1-T3	70	450	1485	95.0	94.5	93.5	0.84	127	7.5	2.0	1.8	2.4	35	13	PTB08ATEX3043/07	2.27	840		
	T1,T2	80	515.0	1483	94.5			0.84	147	6.5	1.7	1.6	2.0	30		PTB08ATEX3043/08				
K11R 315 S4 Ex e IIC	T1-T3	84	540	1485	95.0	94.8	94.0	0.84	152	7.2	2.0	1.8	2.2	25	9	PTB08ATEX3044/05	2.27	875		
	T1,T2	100	645.0	1480	95.1			0.84	183	6.0	1.7	1.6	1.9	20		IBExU02ATEX1137/15				
K11R 315 M4 Ex e IIC	T1-T3	100	643	1485	95.0	95.0	94.5	0.84	181	6.8	1.8	1.7	2.2	30	10	PTB08ATEX3044/06	2.73	1000		
	T1,T2	120	775.0	1478	95.3			0.85	216	5.6	1.2	1.0	1.5	30		IBExU02ATEX1137/01				
K11R 315 MY4 Ex e IIC	T1-T3	115	738	1489	95.4	95.2	94.5	0.85	205	7.1	1.5	1.4	2.4	35	14	PTB08ATEX3044/07	4.82	1200		
K11R 315 L4 Ex e IIC	T1-T3	135	865	1491	96.0	95.5	93.7	0.86	236	7.6	1.4	1.3	2.4	40	18	IBExU02ATEX1137/16	5.93	1450		
	T1,T2	165	1065.0	1480																
K11R 315 LX4 Ex e IIC	T1-T3	170	1090	1490	96.0	95.5	95.0	0.85	300	7.1	1.2	1.1	2.4	45	18	IBExU02ATEX1137/35	6.82	1630		
	T1,T2	200	1291.0	1480																
K12R 355 M4 Ex e IIC	T1-T3	215	1377	1491	96.6	96.0	95.0	0.85	380	8.0	1.4	1.1	2.7	30	8	IBExU01ATEX1009/01	5.60	2150		
	T1,T2	245	1581.0	1480																
K12R 355 MX4 Ex e IIC	T1-T3	240	1538	1490	96.5			0.85	425	8.0	1.5	1.2	2.8				7.90	2400		
	T1,T2	275	1774.0	1480																
K12R 355 L4 Ex e IIC	T1-T3	275	1758	1494	97.1	96.6	95.3	0.84	485	7.9	1.3	1.2	2.7	40	13	IBExU01ATEX1009/02	9.50	2500		
	T1,T2	315	2033.0	1480																

Optionally in dust-protected version, protection type: Protection by enclosure “tb” to EN 60079-31
 for operation in Zone 21 (IBExU 02ATEX 1019 for series K1.R), degree of protection IP 65, double marking on rating plate.
 Other voltages and frequencies upon request. Changes are possible for motors which are not yet certified.

Three-phase motors with squirrel-cage rotor Type of explosion protection – Increased safety „e“ („eb“) for operation in Zone 1 according to EN 60079-7

II 2G Ex e IIC T1/T2, T3 Gb

for rated voltage, temperature classes T1, T2 and T3
with surface cooling, duty type S1, continuous duty
thermal class F, degree of protection IP 55, 50 Hz

Motor selection data														Design point 400 V, 50 Hz				
Type	Temperature class	P _B kW	M _B Nm	n _B rpm	η _B (IEC/EN 60034-2)			cosφ _B	I _B A	I _k /I _B	M _R /M _B	M _S /M _B	M _K /M _B	t _e -time		ATEX no.	J kgm ²	m kg
					100 %	75 %	50 %							T2 s	T3 s			
Synchronous speed 1000 rpm – 6-pole version																		
KPER 80 K6 Ex e IIC	T1-T3	0.37	3.85	920	62	61	54	0.70	1.3	3.2	2.0	1.8	2.0	28	26	IBExU02ATEX1112	0.00130	11.0
KPER 80 G6 Ex e IIC	T1-T3	0.55	5.75	910	66	64	60	0.69	1.75	3.6	2.1	2.1	2.2	26	22	IBExU02ATEX1112	0.00175	12.5
KPER 90 S6 Ex e IIC	T1-T3	0.65	6.7	925	69	68	65	0.71	1.95	3.4	1.8	1.7	1.9	35	30	IBExU02ATEX1113	0.00325	16.0
KPER 90 L6 Ex e IIC	T1-T3	0.95	9.8	925	71	72	69	0.71	2.7	3.9	2.1	2.0	2.2	27	23	IBExU02ATEX1113	0.00425	19.0
KPER 100 L6 Ex e IIC	T1-T3	1.4	14.2	940	75	75	74	0.73	3.75	4.2	2.1	2.0	2.3	24	20	IBExU02ATEX1114	0.00625	24.0
KPER 112 M6 Ex e IIC	T1-T3	1.9	19.1	950	79	80	78	0.74	4.7	5.3	2.2	2.0	2.4	21	18	IBExU02ATEX1115	0.01225	33.5
K11R 132 S6 Ex e IIC	T1-T3	2.60	26	950	80.5	80.0	78.0	0.79	5.9	5.3	1.8	1.8	2.8	22	19	PTB08ATEX3037/13	0.0180	49
	T1,T2	2.60	26.0	950	80.5	80.0	78.0	0.79	5.9	5.3	1.8	1.8	2.8	22	19	PTB08ATEX3037/13		
K11R 132 M6 Ex e IIC	T1-T3	3.50	35	960	82.9	82.5	81.0	0.82	7.4	6.3	2.0	2.0	3.0	24	21	PTB08ATEX3037/14	0.0230	53
	T1,T2	3.50	35.0	960	82.9	82.5	81.0	0.82	7.4	6.3	2.0	2.0	3.0	24	21	PTB08ATEX3037/14		
K11R 132 MX6 Ex e IIC	T1-T3	4.80	48	963	83.5	82.5	82.0	0.83	10	5.1	1.8	1.6	2.5	30	28	PTB08ATEX3037/15	0.0430	70
	T1,T2	4.80	48.0	963	83.5	82.5	82.0	0.83	10	5.1	1.8	1.6	2.5	30	28	PTB08ATEX3037/15		
K11R 160 M6 Ex e IIC	T1-T3	6.60	65	965	84.5	85.0	83.5	0.84	13.4	5.4	1.9	1.6	2.5	35	30	PTB08ATEX3038/19	0.0530	89
	T1,T2	6.60	65.0	965	84.5	85.0	83.5	0.84	13.4	5.4	1.9	1.6	2.5	35	30	PTB08ATEX3038/19		
K11R 160 L6 Ex e IIC	T1-T3	9.7	96	970	85.0	84.5	82.0	0.84	19.6	5.8	2.2	1.9	2.7	30	13	PTB08ATEX3038/20	0.113	123
	T1,T2	9.7	96.0	970	85.0	84.5	82.0	0.84	19.6	5.8	2.2	1.9	2.7	30	13	PTB08ATEX3038/20		
K11R 180 L6 Ex e IIC	T1-T3	13.2	129	975	89.0	89.0	87.0	0.87	24.5	6.5	2.2	2.0	2.9	50	23	PTB08ATEX3039/12	0.228	190
	T1,T2	13.2	129.0	975	89.0	89.0	87.0	0.87	24.5	6.5	2.2	2.0	2.9	50	23	PTB08ATEX3039/12		
K11R 200 L6 Ex e IIC	T1-T3	16.5	161	977	87.5	87.0	83.5	0.82	33	6.8	2.4	2.1	3.2	28	9	PTB08ATEX3040/11	0.228	190
	T1,T2	16.5	161.0	977	87.5	87.0	83.5	0.82	33	6.8	2.4	2.1	3.2	28	9	PTB08ATEX3040/11		
K11R 200 LX6 Ex e IIC	T1-T3	20	195	977	90.5	90.0	88.5	0.90	35.5	6.4	2.2	1.6	2.5	45	18	PTB08ATEX3040/12	0.443	265
	T1,T2	20	195.0	977	90.5	90.0	88.5	0.90	35.5	6.4	2.2	1.6	2.5	45	18	PTB08ATEX3040/12		
K11R 225 M6 Ex e IIC	T1-T3	27	264	975	91.0	91.0	90.5	0.88	49	5.7	2.1	1.8	2.3	40	13	PTB08ATEX3041/11	0.825	360
	T1,T2	27	264.0	975	91.0	91.0	90.5	0.88	49	5.7	2.1	1.8	2.3	40	13	PTB08ATEX3041/11		
K11R 250 M6 Ex e IIC	T1-T3	33	320	985	92.0	91.5	90.0	0.86	60	6.0	2.1	1.7	2.4	35	12	PTB08ATEX3042/07	1.28	475
	T1,T2	33	320.0	985	92.0	91.5	90.0	0.86	60	6.0	2.1	1.7	2.4	35	12	PTB08ATEX3042/07		
K11R 280 S6 Ex e IIC	T1-T3	40	386	990	93.9	93.5	92.5	0.86	71	7.0	1.9	1.8	2.5	55	24	PTB08ATEX3043/09	2.63	715
	T1,T2	40	386.0	990	93.9	93.5	92.5	0.86	71	7.0	1.9	1.8	2.5	55	24	PTB08ATEX3043/09		
K11R 280 M6 Ex e IIC	T1-T3	46	444	990	94.0	93.5	92.5	0.88	80	7.5	1.9	1.6	2.5	60	25	PTB08ATEX3043/10	3.33	810
	T1,T2	50	483.0	988	94.0	93.5	92.5	0.88	87	6.9	1.8	1.5	2.3	60	25	IBExU99ATEX1030/16		
K11R 315 S6 Ex e IIC	T1-T3	64	619	988	94.5	94.0	93.5	0.89	113	7.2	2.2	1.8	2.5	30	9	PTB08ATEX3044/08	3.33	840
	T1,T2	68	658.0	987	94.0	94.0	93.5	0.89	118	6.9	2.1	1.7	2.3	28	9	PTB08ATEX3044/09		
K11R 315 M6 Ex e IIC	T1-T3	76	732	992	95.2	94.6	93.0	0.88	131	7.2	1.6	1.3	2.5	45	17	IBExU99ATEX1137/19	6.00	1080
	T1,T2	82	791.0	990	95.1	94.6	93.0	0.88	141	6.7	1.5	1.2	2.4	40	17	IBExU99ATEX1137/21		
K11R 315 MY6 Ex e IIC	T1-T3	85	820	990	95.2	94.5	94.0	0.87	149	6.9	1.6	1.4	2.5	40	15	IBExU99ATEX1137/04	6.00	1080
	T1,T2	92	890.0	987	95.0	95.0	94.0	0.87	160	6.4	1.5	1.3	2.3	35	15	IBExU99ATEX1137/05		
K11R 315 L6 Ex e IIC	T1-T3	95	921	985	95.0			0.88	165	7.5	2.0	1.4	2.3				6.67	1250
	T1,T2	100	965.0	990														
K11R 315 LX6 Ex e IIC	T1-T3	110	1061	990	95.0			0.88	190	8.0	2.0	1.4	2.3				8.60	1460
	T1,T2	120	1158.0	990														
K12R 355 M6 Ex e IIC	T1-T3	125	1202	993	96.0			0.86	220	8.0	1.5	1.0	2.5				8.20	1650
	T1,T2	135	1302.0	990														
K12R 355 MX6 Ex e IIC	T1-T3	160	1539	993	96.0			0.85	285	8.0	1.5	1.0	2.5				10.10	2100
	T1,T2	175	1688.0	990														
K12R 355 L6 Ex e IIC	T1-T3	200	1923	993	96.0			0.85	355	8.0	1.5	1.0	2.5				14.00	2400
	T1,T2	215	2074.0	990														

Optionally in dust-protected version, protection type: Protection by enclosure "tb" to EN 60079-31
for operation in Zone 21 (IBExU 02ATEX 1019 for series K1.R), degree of protection IP 65, double marking on rating plate.
Other voltages and frequencies upon request. Changes are possible for motors which are not yet certified.

Three-phase motors with squirrel-cage rotor
 Type of explosion protection – Increased safety „e“ („eb“)
 for operation in Zone 1 according to EN 60079-7

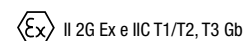

for rated voltage, temperature classes T1, T2 and T3
 with surface cooling, duty type S1, continuous duty
 thermal class F, degree of protection IP 55, 50 Hz

Motor selection data														Design point 400 V, 50 Hz				
Type	Temperature class	P _B kW	M _B Nm	n _B rpm	η _B (IEC/EN 60034-2)			cosφ _B	I _B 400 V A	I _k /I _B	M _k /M _B	M _s /M _B	M _r /M _B	t _c -time		ATEX no.	J	m
					100 %	75 %	50 %							-	-		T2	T3
Synchronous speed 750 rpm – 8-pole version																		
KPER 80 K8 Ex e IIC	T1-T3	0.18	2.6	670	52	50	43	0.64	0.78	2.5	1.6	1.6	1.9	180	150	IBExU02ATEX1112	0.00130	10.5
KPER 80 G8 Ex e IIC	T1-T3	0.25	3.6	670	55	55	49	0.67	1	2.8	2.3	2.3	2.4	70	60	IBExU02ATEX1112	0.00175	12.0
KPER 90 S8 Ex e IIC	T1-T3	0.37	5.0	700	59	56	48	0.56	1.61	2.9	1.5	1.5	2.0	60	55	IBExU02ATEX1113	0.00300	15.0
KPER 90 L8 Ex e IIC	T1-T3	0.55	7.6	695	64	62	55	0.58	2.15	3.0	1.6	1.6	2.1	60	55	IBExU02ATEX1113	0.00375	18.0
KPER 100 L8 Ex e IIC	T1-T3	0.65	8.9	700	66	67	63	0.63	2.25	2.9	1.5	1.5	1.8	70	60	IBExU02ATEX1114	0.00625	23.0
KPER 100 LX8 Ex e IIC	T1-T3	0.95	12.9	705	74	76	72	0.68	2.75	4.1	2.0	2.0	2.5	70	60	IBExU02ATEX1114	0.00900	28.0
KPER 112 M8 Ex e IIC	T1-T3	1.3	17.7	700	75	75	72	0.67	3.9	4.1	1.7	1.7	1.9	60	50	IBExU02ATEX1115	0.01225	33.5
K11R 132 S8 Ex e IIC	T1-T3	1.9	26	700	76.2	76.0	74.0	0.75	4.8	3.9	1.6	1.6	2.2	35	30	PTB08ATEX3037/16	0.01800	49
	T1,T2	1.9	26.0	700	76.2	76.0	74.0	0.75	4.8	3.9	1.6	1.6	2.2	35		PTB08ATEX3037/16		
K11R 132 M8 Ex e IIC	T1-T3	2.6	35	705	78.5	79.0	76.0	0.74	6.5	4.5	1.8	1.7	2.6	30	29	PTB08ATEX3037/17	0.0230	57
	T1,T2	2.6	35.0	705	78.5	79.0	76.0	0.74	6.5	4.5	1.8	1.7	2.6	30		PTB08ATEX3037/17		
K11R 160 M8 Ex e IIC	T1-T3	3.5	46	720	80.0	80.0	76.5	0.72	8.7	4.3	1.8	1.7	2.4	45	40	PTB08ATEX3038/21	0.0430	80
	T1,T2	3.5	46.0	720	80.0	80.0	76.5	0.72	8.7	4.3	1.8	1.7	2.4	45		PTB08ATEX3038/21		
K11R 160 MX8 Ex e IIC	T1-T3	4.8	64	720	81.5	80.5	78.0	0.74	11.6	4.5	1.9	1.8	2.4	50	40	PTB08ATEX3038/22	0.0530	90
	T1,T2	4.8	64.0	720	81.5	80.5	78.0	0.74	11.6	4.5	1.9	1.8	2.4	50		PTB08ATEX3038/22		
K11R 160 L8 Ex e IIC	T1-T3	6.6	86	730	84.0	82.5	79.5	0.73	15.6	5.0	2.1	1.9	2.7	40	35	PTB08ATEX3038/23	0.113	122
	T1,T2	6.6	86.0	730	84.0	82.5	79.5	0.73	15.6	5.0	2.1	1.9	2.7	40		PTB08ATEX3038/23		
K11R 180 L8 Ex e IIC	T1-T3	9.7	128	725	85.0	84.0	81.0	0.73	22.5	5.1	2.3	2.0	2.6	40	12	PTB08ATEX3039/13	0.145	140
	T1,T2	9.7	128.0	725	85.0	84.0	81.0	0.73	22.5	5.1	2.3	2.0	2.6	40		PTB08ATEX3039/13		
K11R 200 L8 Ex e IIC	T1-T3	13.2	173	730	86.5	85.5	82.5	0.72	30.5	5.6	2.3	2.1	2.9	40	13	PTB08ATEX3040/13	0.228	195
	T1,T2	13.2	173.0	730	86.5	85.5	82.5	0.72	30.5	5.6	2.3	2.1	2.9	40		PTB08ATEX3040/13		
K11R 225 S8 Ex e IIC	T1-T3	16.5	216	730	88.5	88.0	85.5	0.81	33.5	6.0	2.2	1.9	2.8	50	20	PTB08ATEX3041/12	0.440	275
	T1,T2	16.5	216.0	730	88.5	88.0	85.5	0.81	33.5	6.0	2.2	1.9	2.8	50		PTB08ATEX3041/12		
K11R 225 M8 Ex e IIC	T1-T3	20	260	735	90.5	90.0	89.0	0.81	39.5	5.3	2.0	1.7	2.2	60	25	PTB08ATEX3041/13	0.825	360
	T1,T2	20	260.0	735	90.5	90.0	89.0	0.81	39.5	5.3	2.0	1.7	2.2	60		PTB08ATEX3041/13		
K11R 250 M8 Ex e IIC	T1-T3	27	350	737	90.5	90.0	88.0	0.80	53.5	5.7	2.3	1.7	2.3	40	13	PTB08ATEX3042/08	1.350	472
	T1,T2	27	350.0	737	90.5	90.0	88.0	0.80	53.5	5.7	2.3	1.7	2.3	40		PTB08ATEX3042/08		
K11R 280 S8 Ex e IIC	T1-T3	33	425	742	93.5	93.0	91.5	0.78	65	6.3	2.0	1.8	2.4	70	30	PTB08ATEX3043/11	2.63	700
	T1,T2	33	425.0	742	93.5	93.0	91.5	0.78	65	6.3	2.0	1.8	2.4	70		PTB08ATEX3043/11		
K11R 280 M8 Ex e IIC	T1-T3	40	516	740	93.8	93.5	92.0	0.79	78	6.5	2.0	1.8	2.4	75	30	PTB08ATEX3043/12	3.33	805
	T1,T2	40	516.0	740	93.8	93.5	92.0	0.79	78	6.5	2.0	1.8	2.4	75		PTB08ATEX3043/12		
K11R 315 S8 Ex e IIC	T1-T3	50	645	740	94.0	93.5	92.5	0.80	96	5.9	1.7	1.6	2.1	50	18	PTB08ATEX3044/10	3.33	850
	T1,T2	50	645.0	740	94.0	93.5	92.5	0.80	96	5.9	1.7	1.6	2.1	50		PTB08ATEX3044/10		
K11R 315 M8 Ex e IIC	T1-T3	68	878	740	94.0	93.5	92.5	0.80	131	6.3	2.1	1.9	2.6	35	9	PTB08ATEX3044/11	3.60	880
	T1,T2	68	878.0	740	94.0	93.5	92.5	0.80	131	6.3	2.1	1.9	2.6	35		PTB08ATEX3044/11		
K11R 315 MY8 Ex e IIC	T1-T3	80	1030	742	94.5	93.5	93.0	0.80	154	6.4	1.4	1.2	2.3	30	12	IBExU99ATEX1137/25	6.00	1080
	T1,T2	80	1030.0	742	94.5	93.5	93.0	0.80	154	6.4	1.4	1.2	2.3	30		IBExU99ATEX1137/25		
K11R 315 L8 Ex e IIC	T1-T3	95	1221	743	94.7	94.1	92.7	0.76	180	7.1	1.7	1.5	2.7	26	8	IBExU99ATEX1137/42	6.76	1290
	T1,T2	95	1221.0	743	94.7	94.1	92.7	0.76	180	7.1	1.7	1.5	2.7	26		IBExU99ATEX1137/42		
K11R 315 LX8 Ex e IIC	T1-T3	115	1484	740	94.5			0.80	220	6.0	1.8	1.7	2.2				8.71	1430
	T1,T2	115	1478.0	743														
K12R 355 M8 Ex e IIC	T1-T3	140	1807	740	95.0			0.79	270	7.5	1.5	1.1	2.5				9.50	1600
	T1,T2	140	1799.0	743														
K12R 355 MX8 Ex e IIC	T1-T3	180	2323	740	95.5			0.79	350	7.5	1.5	1.1	2.5				11.60	2100
	T1,T2	180	2314.0	743														
K12R 355 L8 Ex e IIC	T1-T3	210	2710	740	95.5			0.79	400	7.5	1.5	1.1	2.5				15.80	2400
	T1,T2	210	2699.0	743														

Optionally in dust-protected version, protection type: Protection by enclosure "tb" to EN 60079-31
 for operation in Zone 21 (IBExU 02ATEX 1019 for series K1.R), degree of protection IP 65, double marking on rating plate.
 Other voltages and frequencies upon request. Changes are possible for motors which are not yet certified.

Three-phase motors with squirrel-cage rotor Type of explosion protection – Increased safety „e“ („eb“) for operation in Zone 1 according to EN 60079-7

for rated voltage, temperature classes T1, T2 and T3
with surface cooling, duty type S1, continuous duty
thermal class F, degree of protection IP 55, 60 Hz

Motor selection data													Design point 480 V, 60 Hz				
Type	P _B	M _B	n _B	η _B			cosφ _B	I _B	I _K /I _B	M _K /M _B	M _G /M _B	M _R /M _B	t _e -time		ATEX no.	J	m
	kW	Nm	rpm	100%	75%	50%	-	480 V	-	-	-	-	T2	T3		kgm ²	kg
Synchronous speed 3000 rpm – 2-pole version																	
KPER 63 K2 Ex e IIC	0.18	0.5	3410	63.0			0.74	0.62	4.0	2.3	2.3	2.7	30	29	IBExU02ATEX1110	0.00013	4.9
KPER 63 G2 Ex e IIC	0.25	0.7	3400	66.0	67.0	66.0	0.79	0.83	4.5	2.9	2.9	3.2	15	13	IBExU02ATEX1110	0.00015	5.2
KPER 71 K2 Ex e IIC	0.37	1.05	3375	67.0			0.79	0.83	4.6	2.5	2.5	2.9	18	16	IBExU02ATEX1111	0.00025	6.7
KPER 71 G2 Ex e IIC	0.55	1.5	3410	73.0			0.74	1.25	5.3	2.8	2.8	3.4	13	11	IBExU02ATEX1111	0.00032	7.6
KPER 80 K2 Ex e IIC	0.75	2.1	3430	75.0			0.79	1.53	5.8	2.5	2.3	4.0	16	14	IBExU02ATEX1112	0.00057	10.7
KPER 80 G2 Ex e IIC	1.1	3.05	3450	77.0			0.76	2.25	6.2	2.3	2.3	2.5	10	8	IBExU02ATEX1112	0.00072	11.5
KPER 90 S2 Ex e IIC	1.3	3.6	3450	78.0			0.85	2.40	7.2	2.2	2.2	2.6	16	14	IBExU02ATEX1113	0.00132	16
KPER 90 L2 Ex e IIC	1.85	5.1	3480	81.0			0.83	3.35	8.1	3.0	3.0	3.2	12	9	IBExU02ATEX1113	0.00170	19
KPER 100 L2 Ex e IIC	2.5	6.9	3480	82.0			0.85	4.50	7.4	2.4	2.4	2.7	16	13	IBExU02ATEX1114	0.00275	25
KPER 112 M2 Ex e IIC	3.3	8.9	3525	86.0			0.77	6.00	8.4	2.1	2.1	2.8	16	11	IBExU02ATEX1115	0.0045	32
KPER 112 MX2 Ex e IIC	4.1	11.1	3520	87.0			0.84	7.00	8.6	1.9	1.9	3.0	18	11	IBExU02ATEX1115	0.0055	38
K11R 132 S2 Ex e IIC	5.3	14.0	3515	88.0			0.88	8.3	7.5	1.5	1.2	2.8	26	11	IBExU99ATEX1142/08	0.0110	57
K11R 132 S2G Ex e IIC																0.0110	57
K11R 132 SX2 Ex e IIC	6.3	17.0	3514	89.0			0.88	9.7	8.2	1.6	1.2	2.9	19	8	IBExU99ATEX1142/10	0.0110	57
K12R 132 SX2 Ex e IIC	6.6	18.0	3525	90.5			0.93	9.5	7.8	2.2	1.5	2.8	30	14	IBExU99ATEX1142/24	0.0258	88
K12R 132 SX2G Ex e IIC																0.0258	88
K11R 160 M2 Ex e IIC	8.6	23.0	3545	87.7			0.91	13.0	7.5	2.0	1.7	2.8	40	20	IBExU99ATEX11105/12	0.0575	120
K11R 160 M2G Ex e IIC																0.0575	120
K11R 160 MX2 Ex e IIC	12	33.0	3520	89.5			0.90	18.0	6.8	1.8	1.5	2.5	24	10	IBExU99ATEX11105/14	0.0575	120
K11R 160 MX2G Ex e IIC																0.0575	120
K11R 160 L2 Ex e IIC	14	38.0	3550	90.3			0.91	20.5	8.1	1.9	1.5	3.0	24	10	IBExU99ATEX11105/15	0.0675	138
K11R 160 L2G Ex e IIC																0.0675	138
K11R 180 M2 Ex e IIC	17	46.0	3550	91.0			0.93	24.0	7.5	1.9	1.6	2.8	30	13	IBExU99ATEX11138/09	0.105	175
K11R 180 M2G Ex e IIC																0.105	175
K11R 200 L2 Ex e IIC	23	62.0	3540	91.5			0.93	32.5	7.2	1.9	1.6	2.6	23	8	IBExU99ATEX1143/03	0.128	210
K11R 200 L2G Ex e IIC																0.128	210
K11R 200 LX2 Ex e IIC	27	73.0	3555	93.0			0.91	38.0	7.7	1.7	1.3	2.7	23	10	IBExU99ATEX1143/04	0.193	255
K11R 200 LX2G Ex e IIC																0.193	255
K11R 225 M2 Ex e IIC	33	88.0	3570	93.0			0.91	47.0	7.8	1.6	1.2	2.7	30	13	IBExU99ATEX1144/02	0.375	360
K11R 225 M2G Ex e IIC																0.375	360
K11R 250 M2 Ex e IIC	44	118.0	3570	92.5			0.93	62.0	7.1	1.8	1.4	2.4	35	13	IBExU99ATEX1131/06	0.650	490
K11R 250 M2G Ex e IIC																0.650	490
K11R 280 S2 Ex e IIC	56	150.0	3575	93.5			0.89	81.0	7.2	1.5	1.3	1.8	45	22	IBExU99ATEX1030/06	1.210	730
K11R 280 S2G Ex e IIC																1.210	730
K11R 280 S2G Ex e IIC																1.210	730
K11R 280 M2 Ex e IIC	70	187.0	3570	94.0			0.89	100.0	7.2	1.3	1.2	2.2	35	21	IBExU99ATEX1030/07	1.440	815
K11R 280 M2G Ex e IIC																1.440	815
K11R 315 S2 Ex e IIC	82	219.0	3576	94.5			0.90	116.0	8.2	1.9	1.8	2.6	21	15	IBExU99ATEX11137/07	1.44	850
K11R 315 S2G Ex e IIC																1.44	850
K11R 315 M2 Ex e IIC	96	256.0	3575	95.0			0.89	142.0	7.6	1.8	1.6	2.3				1.76	970
K11R 315 M2G Ex e IIC																1.76	970
K11R 315 MY2 Ex e IIC	132	353.0	3570	94.0			0.93	182.0	7.5	1.5	1.3	3.0	22	8	IBExU99ATEX11137/09	2.82	1150
K11R 315 MY2G Ex e IIC																2.82	1150
K11R 315 L2 Ex e IIC																3.66	1460
K11R 315 L2G Ex e IIC																3.66	1460
K11R 315 LX2 Ex e IIC																4.43	1630
K11R 315 LX2G Ex e IIC																4.43	1630
K12R 355 M2G Ex e IIC																4.20	2000
K12R 355 MX2G Ex e IIC																5.50	2200
K12R 355 L2G Ex e IIC																9.50	2400

Optionally in dust-protected version, protection type: Protection by enclosure "tb" to EN 60079-31
for operation in Zone 21 (IBExU 02ATEX 1019 for series K1.R), degree of protection IP 65, double marking on rating plate.
Other voltages and frequencies upon request. Changes are possible for motors which are not yet certified.

Three-phase motors with squirrel-cage rotor
Type of explosion protection – Increased safety „e“ („eb“)
for operation in Zone 1 according to EN 60079-7

for rated voltage, temperature classes T1, T2 and T3
 with surface cooling, duty type S1, continuous duty
 thermal class F, degree of protection IP 55, 60 Hz

Motor selection data														Design point 480 V, 60 Hz			
Type	P _B	M _B	n _B	η _B			cosφ _B	I _B	I _N /I _B	M _x /M _B	M _y /M _B	M _k /M _B	t _E -time		ATEX no.	J	m
	KW	Nm	rpm	100 %	75 %	50 %	-	480 V	-	-	-	-	T2	T3		kgm ²	kg
Synchronous speed 1500 rpm – 4-pole version																	
KPER 63 K4 Ex e IIC	0.12	0.7	1670	56.0	58.0	57.0	0.68	0.46	3.2	1.8	1.8	2.2	70	50	IBExU02ATEX1110	0.00019	4.8
KPER 63 G4 Ex e IIC	0.18	1.05	1660				0.69	0.52	3.5	2.2	2.2	2.5	35	30	IBExU02ATEX1110	0.00024	5.2
KPER 71 K4 Ex e IIC	0.25	1.4	1680				0.73	0.66	3.7	1.8	1.8	2.2	27	24	IBExU02ATEX1111	0.00040	6.8
KPER 71 G4 Ex e IIC	0.37	2.1	1670				0.75	0.90	3.9	1.8	1.8	2.4	21	18	IBExU02ATEX1111	0.00050	7.8
KPER 80 K4 Ex e IIC	0.55	3.1	1695				0.71	1.38	4.3	1.8	1.8	2.0	16	13	IBExU02ATEX1112	0.00087	10.6
KPER 80 G4 Ex e IIC	0.75	4.25	1690	72.0	73.0	71.0	0.74	1.70	4.8	2.1	2.0	2.3	17	14	IBExU02ATEX1112	0.00107	11.7
KPER 90 S4 Ex e IIC	1.00	5.6	1715				0.77	2.10	5.5	2.4	2.3	2.6	19	17	IBExU02ATEX1113	0.00207	15.5
KPER 90 L4 Ex e IIC	1.35	7.5	1720				0.78	2.70	6.0	2.3	2.0	2.5	14	12	IBExU02ATEX1113	0.00260	18.0
KPER 100 L4 Ex e IIC	2.0	11.0	1730				0.74	4.05	6.6	2.5	2.3	2.9	13	11	IBExU02ATEX1114	0.00400	23.5
KPER 100 LX4 Ex e IIC	2.5	13.65	1750				0.74	4.85	7.3	2.3	2.2	2.9	12	11	IBExU02ATEX1114	0.00725	30.0
KPER 112 M4 Ex e IIC	3.6	19.65	1750				0.73	7.00	7.7	2.8	2.4	2.9	9	7	IBExU02ATEX1115	0.0090	37.0
K11R 132 S4 Ex e IIC	5.8	32.0	1740	86.0			0.82	10.0	6.9	2.0	1.7	2.9	15	9	IBExU99ATEX1142/11	0.0150	53
K11R 132 M4 Ex e IIC	7.8	42.0	1760	88.5			0.80	13.2	6.5	2.2	1.9	2.8	27	9	IBExU99ATEX1142/12	0.028	72
K11R 160 M4 Ex e IIC	12.0	65.0	1765	91.0			0.88	18.1	6.5	2.0	1.7	2.5	30	14	IBExU99ATEX1105/16	0.078	123
K11R 160 L4 Ex e IIC	15.5	83.0	1775	91.0			0.85	24.0	7.9	2.6	2.1	3.2	23	7	IBExU99ATEX1105/17	0.090	136
K11R 180 M4 Ex e IIC	17	91.0	1775	90.5			0.87	26.0	7.3	2.0	1.7	2.7	35	12	IBExU99ATEX1138/10	0.138	180
K11R 180 L4 Ex e IIC	20	108.0	1775	91.0	90.0	87.5	0.84	32.0	7.6	2.2	1.9	2.9	23	7	IBExU99ATEX1138/12	0.138	185
K11R 200 L4 Ex e IIC	28	151.0	1775	93.0	92.1	90.0	0.88	41.5	7.2	1.9	1.6	2.5	30	7	IBExU99ATEX1143/05	0.275	270
K11R 225 S4 Ex e IIC	36	194.0	1775	93.4			0.85	55	6.2	1.7	1.4	1.9	30	12	IBExU99ATEX1144/04	0.525	380
K12R 225 S4 Ex e IIC																0.525	380
K11R 225 M4 Ex e IIC	43	231.0	1780	93.9			0.85	65	7.5	2.2	1.7	2.3	18	7	IBExU99ATEX1144/05	0.525	385
K11R 250 M4 Ex e IIC	52	278.0	1785	94.0			0.85	78	7.4	1.9	1.6	2.2	26	9	IBExU99ATEX1131/09	0.95	530
K11R 280 S4 Ex e IIC	70	375.0	1785	94.0			0.84	107	7.2	1.8	1.6	2.2	30	9	IBExU99ATEX1030/10	1.96	765
K11R 280 M4 Ex e IIC	84	449.0	1785	94.0			0.83	129	7.5	1.7	1.6	2.3	29	8	IBExU99ATEX1030/11	2.27	840
K11R 315 S4 Ex e IIC	100	535.0	1785	95.0			0.84	152	7.3	2.1	1.9	2.3	21	6	IBExU99ATEX1137/11	2.27	875
K11R 315 M4 Ex e IIC	120	643.0	1783	95.6			0.85	215	7.0	1.2	1.1	1.8	24	6	IBExU99ATEX1137/43	2.73	1000
K11R 315 MY4 Ex e IIC	132	704.0	1790	95.0			0.85	197	7.5	1.5	1.4	2.5	30	12	IBExU99ATEX1137/13	4.82	1200
K11R 315 L4 Ex e IIC																5.93	1450
K11R 315 LX4 Ex e IIC																6.82	1630
K12R 355 M4 Ex e IIC																5.60	2150
K12R 355 MX4 Ex e IIC																7.90	2400
K12R 355 L4 Ex e IIC																9.50	2500

Optionally in dust-protected version, protection type: Protection by enclosure "tb" to EN 60079-31
 for operation in Zone 21 (IBExU 02ATEX 1019 for series K1.R), degree of protection IP 65, double marking on rating plate.
 Other voltages and frequencies upon request. Changes are possible for motors which are not yet certified.

Three-phase motors with squirrel-cage rotor Type of explosion protection – Increased safety „e“ („eb“) for operation in Zone 1 according to EN 60079-7

for rated voltage, temperature classes T1, T2 and T3
with surface cooling, duty type S1, continuous duty
thermal class F, degree of protection IP 55, 60 Hz

Motor selection data													Design point 480 V, 60 Hz				
Type	P _B kW	M _B Nm	n _B rpm	η _B (IEC/EN 60034-2)			cosφ _B -	I _B 480 V A	I _K /I _B -	M _K /M _B -	M _G /M _B -	M _R /M _B -	t _e -time		ATEX no.	J kgm ²	m kg
				100 %	75 %	50 %							T2 s	T3 s			
Synchronous speed 1000 rpm – 6-pole version																	
KPER 80 K6 Ex e IIC	0.37	3.1	1130	61.0			0.65	1.13	3.5	2.0	1.8	2.0	28	26	IBExU02ATEX1112	0.00130	11.0
KPER 80 G6 Ex e IIC	0.55	4.7	1110	66.0			0.69	1.46	4.0	2.1	2.1	2.2	26	22	IBExU02ATEX1112	0.00175	12.5
KPER 90 S6 Ex e IIC	0.65	5.5	1135	69.0			0.67	1.69	3.7	1.8	1.7	1.9	35	30	IBExU02ATEX1113	0.00325	16.0
KPER 90 L6 Ex e IIC	0.95	8.1	1125	71.5			0.71	2.25	4.3	2.1	2.0	2.2	27	23	IBExU02ATEX1113	0.00425	19.0
KPER 100 L6 Ex e IIC	1.40	11.6	1150	75.0			0.69	3.25	4.6	2.1	2.0	2.3	24	20	IBExU02ATEX1114	0.00625	24.0
KPER 112 M6 Ex e IIC	1.90	15.7	1155	79.0			0.71	4.10	5.8	2.0	2.0	2.4	21	18	IBExU02ATEX1115	0.01225	33.5
K11R 132 S6 Ex e IIC	3.00	25.0	1155	82.0			0.79	5.7	5.8	2.0	1.9	3.0	21	18	IBExU99ATEX1142/13	0.0180	49
K11R 132 M6 Ex e IIC	4.00	33.0	1160	84.5			0.80	7.1	6.9	2.2	2.1	3.3	23	20	IBExU99ATEX1142/14	0.0230	53
K11R 132 MX6 Ex e IIC	5.50	45.0	1166	85.5			0.82	9.5	5.8	1.9	1.7	2.6	29	26	IBExU99ATEX1142/15	0.0430	70
K11R 160 M6 Ex e IIC	7.6	62.0	1165	86.5			0.82	12.9	5.8	2.0	1.7	2.6	30	24	IBExU99ATEX1105/18	0.0530	89
K11R 160 L6 Ex e IIC	11.0	90.0	1170	86.0			0.82	18.7	6.3	2.3	2.1	2.9	29	11	IBExU99ATEX1105/19	0.113	123
K11R 180 L6 Ex e IIC	15.0	122.0	1178	89.5			0.87	23.0	7.1	2.3	2.1	3.0	45	20	IBExU99ATEX1138/14	0.228	190
K11R 200 L6 Ex e IIC	19.0	154.0	1175	88.0			0.80	32.5	7.0	2.6	2.1	3.3				0.228	190
K11R 200 LX6 Ex e IIC	23	186.0	1178	90.5			0.90	34.0	6.8	2.2	1.7	2.5	40	14	IBExU99ATEX1143/06	0.443	265
K11R 225 M6 Ex e IIC	32	260.0	1177	92.0			0.88	47.5	6.1	2.2	1.8	2.3	30	10	IBExU99ATEX1144/06	0.825	360
K11R 250 M6 Ex e IIC	40	323.0	1181	93.0			0.88	59	6.5	2.1	1.5	2.2	26	12	IBExU99ATEX1131/10	1.28	475
K11R 280 S6 Ex e IIC	48	385.0	1190	94.0			0.87	71	7.5	2.1	1.7	2.5				2.63	715
K11R 280 M6 Ex e IIC	55	441.0	1190	94.0			0.87	81	8.1	2.2	2.0	2.9				3.33	810
K11R 315 S6 Ex e IIC	76	610.0	1190	94.5			0.87	111	8.7	2.3	2.1	3.0				3.33	840
K11R 315 M6 Ex e IIC	90	722.0	1191	95.1	94.6	93.0	0.88	130	7.4	1.6	1.3	2.5	35	12	IBExU99ATEX1137/22	6.00	1080
K11R 315 MY6 Ex e IIC	100															6.00	1080
K11R 315 L6 Ex e IIC																6.67	1250
K11R 315 LX6 Ex e IIC																8.60	1460
K12R 355 M6 Ex e IIC																8.20	1650
K12R 355 MX6 Ex e IIC																10.10	2100
K12R 355 L6 Ex e IIC																14.00	2400
Synchronous speed 750 rpm - 8-pole version																	
KPER 80 K8 Ex e IIC	0.18	2.1	820	52.0			0.64	0.65	2.7	1.6	1.6	1.9	180	150	IBExU02ATEX1112	0.00130	10.5
KPER 80 G8 Ex e IIC	0.25	2.9	830	56.0			0.62	0.87	3.1	2.3	2.3	2.4	70	60	IBExU02ATEX1112	0.00175	12.0
KPER 90 S8 Ex e IIC	0.37	4.2	850	59.0			0.56	1.34	3.2	1.5	1.5	2	60	55	IBExU02ATEX1113	0.00300	15.0
KPER 90 L8 Ex e IIC	0.55	6.2	845	64.0			0.58	1.78	3.3	1.6	1.6	2.1	60	55	IBExU02ATEX1113	0.00375	18.0
KPER 100 L8 Ex e IIC	0.65	7.3	855	67			0.60	1.95	3.3	1.5	1.5	1.8	70	60	IBExU02ATEX1114	0.00625	23.0
KPER 100 LX8 Ex e IIC	0.95	10.5	860	74.5			0.64	2.40	4.5	2.0	2.0	2.5	70	60	IBExU02ATEX1114	0.00900	28.0
KPER 112 M8 Ex e IIC	1.30	14.4	860	75.5			0.61	3.40	4.5	1.7	1.7	1.9	60	50	IBExU02ATEX1115	0.01225	33.5
K11R 132 S8 Ex e IIC	2.2	25.0	850	75.0			0.77	4.6	4.6	1.7	1.4	1.9	35	30	IBExU99ATEX1142/16	0.01800	49
K11R 132 M8 Ex e IIC	3.0	34.0	850	80.8			0.76	6.0	4.9	1.8	1.7	2.3	30	28	IBExU99ATEX1142/17	0.0230	57
K11R 160 M8 Ex e IIC	4.0	44.0	875	82.0			0.70	8.4	4.6	2.0	1.9	2.5	45	35	IBExU99ATEX1105/20	0.0430	80
K11R 160 MX8 Ex e IIC	5.5	60.0	870	83.5			0.71	11.2	4.9	2.0	1.9	2.5	45	35	IBExU99ATEX1105/21	0.0530	90
K11R 160 L8 Ex e IIC	7.6	82.0	880	84.5			0.71	15.3	5.4	2.3	2.0	2.8	35	25	IBExU99ATEX1105/22	0.113	122
K11R 180 L8 Ex e IIC	11.0	120.0	875	85.5			0.71	22.0	5.5	2.5	2.1	2.9	35	10	IBExU99ATEX1138/15	0.145	140
K11R 200 L8 Ex e IIC	15.0	163.0	880	87.5			0.70	29.5	5.7	2.4	2.2	3.1				0.228	195
K11R 225 S8 Ex e IIC	19.5	210.0	885	90.0	89.7	87.7	0.78	33.5	6.5	2.1	1.8	2.7	40	14	IBExU99ATEX1144/34	0.440	275
K11R 225 M8 Ex e IIC	24	259.0	885	91.0			0.80	39.7	5.4	2.1	1.8	2.2				0.825	360
K11R 250 M8 Ex e IIC	32	345.0	885	90.5			0.81	52.5	5.3	2.1	1.6	2.1				1.350	472
K11R 280 S8 Ex e IIC	40	427.0	895	93.5			0.78	66	6.3	1.9	1.7	2.3				2.63	700
K11R 280 M8 Ex e IIC	48	514.0	892	94.0			0.79	78	6.5	2.1	1.8	2.4				3.33	805
K11R 315 S8 Ex e IIC	60	644.0	890	94.0			0.81	95	6.0	1.7	1.6	2.1				3.33	850
K11R 315 M8 Ex e IIC	82	880.0	890	94.0			0.78	135	7.0	2.1	1.8	2.5				3.60	880
K11R 315 MY8 Ex e IIC	95	1015.0	894	94.7	9.4	93.0	0.79	152	6.6	1.4	1.2	2.3	28	10	IBExU99ATEX1137/27	6.00	1080
K11R 315 L8 Ex e IIC																6.76	1290
K11R 315 LX8 Ex e IIC																8.71	1430
K12R 355 M8 Ex e IIC																9.50	1600
K12R 355 MX8 Ex e IIC																11.60	2100
K12R 355 L8 Ex e IIC																15.80	2400

Optionally in dust-protected version, protection type: Protection by enclosure "tb" to EN 60079-31
for operation in Zone 21 (IBExU 02ATEX 1019 for series K1.R), degree of protection IP 65, double marking on rating plate.
Other voltages and frequencies upon request. Changes are possible for motors which are not yet certified.

Three-phase motors with squirrel-cage rotor
Type of explosion protection – Increased safety „e“ („eb“)
for operation in Zone 1 according to EN 60079-7

for extended voltage range, temperature classes T1, T2 and T3
 with surface cooling, duty type S1, continuous duty
 thermal class F, degree of protection IP 55, 50 Hz

Motor selection data													Design point 380...420 V, 50 Hz				
Type	P _B	M _B	n _B	η _B			cosφ _B	I _B	I _N /I _B	M _K /M _B	M _S /M _B	M _K /M _B	t _e -time		ATEX no.	J	m
	kW	Nm	rpm	(IEC/EN 60034-2)				380...420 V					T2	T3		kgm ²	kg
Synchronous speed 3000 rpm – 2-pole version																	
				100%	75%	50%	-	A	-	-	-	-	s	s			
KPER 63 K2 Ex e IIC	0.18	0.60	2710..2810	61			0.85..0.75	0.53	3.7	1.6	1.6	2.0	30	29	IBExU02ATEX1110	0.00013	4.9
KPER 63 G2 Ex e IIC	0.25	0.85	2700..2760	68	69	67	0.88..0.83	0.62	4.2	2.1	2.1	2.2		25	IBExU02ATEX1110	0.00015	5.2
KPER 71 K2 Ex e IIC	0.37	1.3	2700..2780	67			0.89..0.79	0.97	4.1	1.7	1.7	2.2	18	16	IBExU02ATEX1111	0.00025	6.7
KPER 71 G2 Ex e IIC	0.55	1.9	2740..2810	73			0.84..0.74	1.43	4.8	2.2	2.2	2.5	13	11	IBExU02ATEX1111	0.00032	7.6
KPER 80 K2 Ex e IIC	0.75	2.55	2780..2830	74			0.88..0.79	1.76	5.3	1.9	1.9	2.4	16	14	IBExU02ATEX1112	0.00057	10.7
KPER 80 G2 Ex e IIC	1.10	3.7	2800..2850	77			0.86..0.76	2.6	5.6	2.5	2.3	2.5	10	8	IBExU02ATEX1112	0.00072	11.5
KPER 90 S2 Ex e IIC	1.30	4.35	2830..2860	78			0.90..0.85	2.75	6.5	2.4	2.2	2.6	16	14	IBExU02ATEX1113	0.00132	16
KPER 90 L2 Ex e IIC	1.85	6.15	2850..2880	83			0.89..0.83	3.85	7.4	3.0	3.0	3.2	12	9	IBExU02ATEX1113	0.00170	19
KPER 100 L2 Ex e IIC	2.50	8.3	2850..2880	82			0.88..0.85	5.2	6.8	2.5	2.4	2.7	14	11	IBExU02ATEX1114	0.00275	25
KPER 112 M2 Ex e IIC	3.30	10.8	2905..2925	85			0.85..0.77	6.9	7.7	2.3	2.1	3.1	16	11	IBExU02ATEX1115	0.0045	32
KPER 112 MX2 Ex e IIC	4.10	13.5	2900..2920	87			0.89..0.84	8.1	7.9	2.5	1.9	3.3	18	11	IBExU02ATEX1115	0.0055	38
K11R 132 S2 Ex e IIC	4.60	15.0	2900	87.5	87.0	85.5	0.88	9.2	6.6	1.4	1.2	2.8	28	11	PTB08ATEX3037/01	0.0110	57
K11R 132 S2G Ex e IIC																0.0110	57
K11R 132 SX2 Ex e IIC																0.0110	57
K12R 132 SX2 Ex e IIC	5.5	18.0	2930	89.5	89.0	86.0	0.92	10.1	7.0	2.1	1.3	2.6	35	16	IBExU99ATEX1142/22	0.0258	88
K12R 132 SX2G Ex e IIC																0.0258	88
K11R 160 M2 Ex e IIC	7.5	24.0	2945	87.5	87.0	82.5	0.90	14.4	6.6	1.9	1.6	2.7	40	19	PTB08ATEX3038/01	0.0575	120
K11R 160 M2G Ex e IIC																0.0575	120
K11R 160 MX2 Ex e IIC	10.0	33.0	2935	89.5	89.0	87.5	0.90	19.1	6.1	1.8	1.5	2.5	28	11	PTB08ATEX3038/02	0.0575	120
K11R 160 MX2G Ex e IIC																0.0575	120
K11R 160 L2 Ex e IIC	12.5	41.0	2945	90.0	89.5	88.0	0.91	23	7.0	1.8	1.4	2.8	27	10	PTB08ATEX3038/03	0.0675	138
K11R 160 L2G Ex e IIC																0.0675	138
K11R 180 M2 Ex e IIC	15	49.0	2945	91.0	90.0	88.5	0.92	27	6.6	1.8	1.5	2.6	30	13	PTB08ATEX3039/07	0.105	175
K11R 180 M2G Ex e IIC																0.105	175
K11R 200 L2 Ex e IIC	20	65.0	2935	91.5	91.5	90.0	0.92	36	6.2	1.8	1.3	2.4	25	8	PTB08ATEX3040/01	0.128	210
K11R 200 L2G Ex e IIC																0.128	210
K11R 200 LX2 Ex e IIC	24	78.0	2950	93.0	92.5	91.5	0.90	43	6.6	1.6	1.2	2.5	24	9	PTB08ATEX3040/02	0.193	255
K11R 200 LX2G Ex e IIC	24	78.0	2953	93.5	93.0	91.0	0.90			1.4	1.0	2.3			IBExU99ATEX1143/15	0.193	255
K11R 225 M2 Ex e IIC	28	90.0	2970	93.0	92.5	91.0	0.91	50	7.1	1.5	1.0	2.6	30	14	PTB08ATEX3041/01	0.375	360
K11R 225 M2G Ex e IIC	28	90.0	2968	94.3			0.92		7.8	1.4	1.0	2.7				0.375	360
K11R 250 M2 Ex e IIC	36	116.0	2970	93.2	92.5	90.5	0.93	63	6.8	1.9	1.5	2.6	40	18	PTB08ATEX3042/01	0.650	490
K11R 250 M2G Ex e IIC	36															0.650	490
K11R 280 S2 Ex e IIC	47	151.0	2970	93.7	93.5	92.0	0.88	86	6.7	1.4	1.3	2.2	50	23	IBExU99ATEX1030/17	1.210	730
K11R 280 S2G Ex e IIC																1.210	730
K11R 280 M2 Ex e IIC	58	186.0	2975	94.1	93.0	91.0	0.88	107	6.7	1.4	1.3	2.1	35	21	PTB08ATEX3043/01	1.440	815
K11R 280 M2G Ex e IIC	58	186.0	2975	94.1	93.0	91.0	0.88			1.4	1.3	2.1				1.440	815
K11R 315 S2 Ex e IIC	68	218.0	2975	95.0	94.5	93.5	0.90	122	7.1	1.8	1.6	2.3	29	13	IBExU99ATEX1137/23	1.44	850
K11R 315 S2G Ex e IIC	68	218.0	2974	94.3	87.0	92.0	0.90			1.5	1.3	2.1				1.44	850
K11R 315 M2 Ex e IIC	80	257.0	2975	95.3	94.7	94.0	0.90			1.8	1.6	2.2				1.76	970
K11R 315 M2G Ex e IIC	80	257.0	2975	95.3	94.7	94.0	0.90			1.8	1.6	2.2				1.76	970
K11R 315 MY2 Ex e IIC	110	354.0	2970	95.0	94.5	93.5	0.93	189	6.9	1.5	1.3	3.0	24	9	IBExU99ATEX1137/28	2.82	1150
K11R 315 MY2G Ex e IIC	110	354.0	2970	95.2	95.0	93.0	0.93			1.3	1.2	2.7				2.82	1150
K11R 315 L2 Ex e IIC	125	401.0	2980	95.3	95.0	93.5	0.93			1.5	1.3	2.8				3.66	1460
K11R 315 L2G Ex e IIC	125	401.0	2980	95.3	95.0	93.5	0.93			1.5	1.3	2.8				3.66	1460
K11R 315 LX2 Ex e IIC	150	480.0	2985	95.8	95.4	93.5	0.95			1.1	0.9	2.7				4.43	1630
K11R 315 LX2G Ex e IIC	150	480.0	2985	95.8	95.4	93.5	0.95			1.1	0.9	2.7				4.43	1630
K12R 355 M2G Ex e IIC	190	609.0	2980							1.4	1.1	2.6				4.20	2000
K12R 355 MX2G Ex e IIC	220	705.0	2980							1.4	1.1	2.6				5.50	2200
K12R 355 L2G Ex e IIC																9.50	2400

Optionally in dust-protected version, protection type: Protection by enclosure "tb" to EN 60079-31
 for operation in Zone 21 (IBExU 02ATEX 1019 for series K1.R), degree of protection IP 65, double marking on rating plate.
 Other voltages and frequencies upon request. Changes are possible for motors which are not yet certified.

Three-phase motors with squirrel-cage rotor Type of explosion protection – Increased safety „e“ („eb“) for operation in Zone 1 according to EN 60079-7

for extended voltage range, temperature classes T1, T2 and T3
with surface cooling, duty type S1, continuous duty
thermal class F, degree of protection IP 55, 50 Hz

Motor selection data													Design point 380...420 V, 50 Hz				
Type	P _B kW	M _B Nm	n _B rpm	η _B (IEC/EN 60034-2)			cosφ _B -	I _B 380...420 V A	I _N /I _B -	M _K /M _B -	M _S /M _B -	M _R /M _B -	t _E -time		ATEX no.	J kgm ²	m kg
				100%	75%	50%							T2 s	T3 s			
Synchronous speed 1500 rpm – 4-pole version																	
KPER 63 K4 Ex e IIC	0.12	0.12	1340...1380	63	64	62	0.78...0.68	0.37	3.3	1.9	1.9	2.0	75	70	IBExU02ATEX1110	0.00019	4.8
KPER 63 G4 Ex e IIC	0.18	0.18	1340...1380	62.5			0.78...0.68	0.37	3.3	1.9	1.9	2.2	75	70	IBExU02ATEX1110	0.00024	5.2
KPER 71 K4 Ex e IIC	0.25	0.25	1350...1390	65			0.79...0.69	0.79	3.4	1.4	1.4	1.8	27	24	IBExU02ATEX1111	0.00040	6.8
KPER 71 G4 Ex e IIC	0.37	0.37	1350...1390	67			0.79...0.70	1.08	3.6	1.6	1.6	2.0	21	18	IBExU02ATEX1111	0.00050	7.8
KPER 80 K4 Ex e IIC	0.55	0.55	1365...1395	69			0.80...0.71	1.59	3.9	1.8	1.8	2.0	16	13	IBExU02ATEX1112	0.00087	10.6
KPER 80 G4 Ex e IIC	0.75	0.75	1320...1360	70	72	73	0.84...0.77	2.00	3.8	1.9	1.8	1.9	20	16	IBExU02ATEX1112	0.00107	11.7
KPER 90 S4 Ex e IIC	1.00	1.00	1395...1415	77			0.84...0.77	2.4	5.1	2.4	2.3	2.5	19	17	IBExU02ATEX1113	0.00207	15.5
KPER 90 L4 Ex e IIC	1.35	1.35	1395...1420	79			0.84...0.78	3.10	5.5	2.3	1.8	2.5	14	12	IBExU02ATEX1113	0.00260	18.0
KPER 100 L4 Ex e IIC	2.00	2.00	1410...1430	80			0.82...0.74	4.65	6.0	2.8	2.6	2.9	13	11	IBExU02ATEX1114	0.00400	23.5
KPER 100 LX4 Ex e IIC	2.50	2.50	1435...1450	83			0.81...0.74	5.60	6.7	2.3	2.2	2.9	12	11	IBExU02ATEX1114	0.00725	30.0
KPER 112 M4 Ex e IIC	3.60	3.60	1430...1450	85			0.82...0.73	8.10	7.0	2.8	2.1	2.9	9	7	IBExU02ATEX1115	0.0090	37.0
K11R 132 S4 Ex e IIC	5.0	33.0	1435	84.5	84.0	83.0	0.83	10.5	6.3	2.0	1.6	2.8	16	8	PTB08ATEX3037/02	0.0150	53
K11R 132 M4 Ex e IIC	6.8	45.0	1455	87.5	87.0	86.0	0.85...0.78	14	5.9	2.1	1.8	2.7	27	10	PTB08ATEX3037/03	0.028	72
K11R 160 M4 Ex e IIC	10.0	65.0	1465	91.0	90.5	89.5	0.89	18.9	6.1	2.0	1.7	2.5	35	16	PTB08ATEX3038/04	0.078	123
K11R 160 L4 Ex e IIC	13.5	88.0	1470	90.5	90.0	88.0	0.87...0.83	26	7.4	2.5	2.0	3.0	25	7	PTB08ATEX3038/05	0.090	136
K11R 180 M4 Ex e IIC	15.0	97.0	1475	90.5	90.0	88.0	0.87	28.5	6.4	1.9	1.6	2.5	40	13	PTB08ATEX3039/02	0.138	180
K11R 180 L4 Ex e IIC	17.5	113.0	1475	90.5	90.0	88.0	0.86...0.82	34	6.9	2.1	1.8	2.8	27	8	PTB08ATEX3039/03	0.138	185
K11R 200 L4 Ex e IIC	24.0	155.0	1477	92.7	92.5	91.0	0.87	45	6.4	1.8	1.5	2.4	30	8	PTB08ATEX3040/03	0.275	270
K11R 225 S4 Ex e IIC	30.0	194.0	1475	93.0	92.5	92.0	0.85	59	5.7	1.6	1.4	1.9	30	12	PTB08ATEX3041/02	0.525	380
K12R 225 S4 Ex e IIC	30.0	194.0	1482	92.8	93.3	92.8	0.84	58	7.1	1.9	2.1	1.6	29	9	IBExU99ATEX1144/41	0.525	380
K11R 225 M4 Ex e IIC	36.0	232.0	1480	94.0	93.5	92.5	0.85	69	7.0	2.2	1.7	2.3	20	7	PTB08ATEX3041/03	0.525	385
K11R 250 M4 Ex e IIC	44.0	283.0	1485	94.0	93.5	92.5	0.86	83	6.9	1.8	1.6	2.1	29	9	PTB08ATEX3042/02	0.95	530
K11R 280 S4 Ex e IIC	58.0	373.0	1485	94.2	93.7	92.5	0.84	113	6.7	1.8	1.6	2.2	40	13	IBExU99ATEX1030/18	1.96	765
K11R 280 M4 Ex e IIC	70.0	450.0	1485	95.0	94.5	93.5	0.84	135	7.1	2.0	1.8	2.4	30	11	PTB08ATEX3043/02	2.27	840
K11R 315 S4 Ex e IIC	84	540.0	1485	95.0	94.8	94.0	0.84	159	6.9	2.0	1.8	2.2	25	7	IBExU99ATEX1137/24	2.27	875
K11R 315 M4 Ex e IIC	100	643.0	1485	95.0	95.0	94.5	0.84	191	6.5	1.8	1.7	2.2	27	8	IBExU99ATEX1137/54	2.73	1000
K11R 315 MY4 Ex e IIC	115	739.0	1487	95.4	95.2	94.5	0.85	217	6.7	1.5	1.4	2.4	35	12	IBExU99ATEX1137/29	4.82	1200
K11R 315 L4 Ex e IIC	135	865.0	1491	96.0	95.5	93.7	0.86	248	7.2	1.4	1.3	2.4	40	16	IBExU99ATEX1137/17	5.93	1450
K11R 315 LX4 Ex e IIC	170	1090.0	1490	96.0	95.5	95.0	0.85			1.2	1.1	2.4				6.82	1630
K12R 355 M4 Ex e IIC	215	1377.0	1491	96.6	96.0	95.0	0.85			1.4	1.1	2.7				5.60	2150
K12R 355 MX4 Ex e IIC	240	1538.0	1490							1.5	1.2	2.8				7.90	2400
K12R 355 L4 Ex e IIC	275	1763.0	1490							1.6	1.2	2.8				9.50	2500

Optionally in dust-protected version, protection type: Protection by enclosure "tb" to EN 60079-31
for operation in Zone 21 (IBExU 02ATEX 1019 for series K1.R), degree of protection IP 65, double marking on rating plate.
Other voltages and frequencies upon request. Changes are possible for motors which are not yet certified.

Three-phase motors with squirrel-cage rotor
Type of explosion protection – Increased safety „e“ („eb“)
for operation in Zone 1 according to EN 60079-7

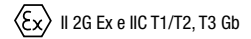

for extended voltage range, temperature classes T1, T2 and T3
with surface cooling, duty type S1, continuous duty
thermal class F, degree of protection IP 55, 50 Hz

Motor selection data													Design point 380...420 V, 50 Hz				
Type	P_B	M_B	n_B	η_B			$\cos\varphi_B$	I_B	I_A/I_B	M_A/M_B	M_S/M_B	M_K/M_B	t_e -time		ATEX no.	J	m
	kW	Nm		rpm	(IEC/EN 60034-2)								T2	T3			
				100%	75%	50%	-	A	-	-	-	-	s	s		kgm ²	kg
Synchronous speed 1000 rpm – 6-pole version																	
KPER 80 K6 Ex e IIC	0.37	0.37	905..930	62			0.74..0.65	1.3	3.2	2.0	1.8	2.0	28	26	IBEXU02ATEX1112	0.00130	11.0
KPER 80 G6 Ex e IIC																0.00175	12.5
KPER 90 S6 Ex e IIC	0.65	0.65	915..935	69			0.74..0.67	1.95	3.4	1.8	1.7	1.9	35	30	IBEXU02ATEX1113	0.00325	16.0
KPER 90 L6 Ex e IIC																0.00425	19.0
KPER 100 L6 Ex e IIC	1.40	1.40	930..950	75			0.76..0.69	3.75	4.2	2.1	2.0	2.3	24	20	IBEXU02ATEX1114	0.00625	24.0
KPER 112 M6 Ex e IIC	1.90	1.90	945..955	79			0.78..0.71	4.7	5.3	2.2	2.0	2.4	21	18	IBEXU02ATEX1115	0.01225	33.5
K11R 132 S6 Ex e IIC	2.60	26.0	950	80.5	80.0	78.0	0.83..0.77	6.1	5.1	1.8	1.8	2.8	21	18	PTB08ATEX3037/04	0.0180	49
K11R 132 M6 Ex e IIC	3.50	35.0	960	82.9	82.5	81.0	0.85..0.79	7.5	6.2	2.0	2.0	3.0	23	20	PTB08ATEX3037/05	0.0230	53
K11R 132 MX6 Ex e IIC	4.80	48.0	963	83.5	82.5	82.0	0.83	10.3	5.0	1.8	1.6	2.5	30	26	PTB08ATEX3037/06	0.0430	70
K11R 160 M6 Ex e IIC	6.60	65.0	965	84.5	85.0	83.5	0.86..0.82	13.8	5.2	1.9	1.6	2.5	30	26	PTB08ATEX3038/06	0.0530	89
K11R 160 L6 Ex e IIC	9.7	96.0	970	85.0	84.5	82.0	0.87..0.80	20	5.6	2.2	1.9	2.7	29	12	PTB08ATEX3038/07	0.113	123
K11R 180 L6 Ex e IIC	13.2	129.0	975	89.0	89.0	87.0	0.87	25.5	6.2	2.2	2.0	2.9	45	21	PTB08ATEX3039/04	0.228	190
K11R 200 L6 Ex e IIC	16.5	161.0	977	87.5	87.0	83.5	0.82		2.4	2.1	3.2				0.228	190	
K11R 200 LX6 Ex e IIC	20.0	195.0	977	90.5	90.0	88.5	0.90	37.5	6.0	2.2	1.6	2.5	45	14	PTB08ATEX3040/04	0.443	265
K11R 225 M6 Ex e IIC	27.0	264.0	975	91.0	91.0	90.5	0.88..0.84	51	5.4	2.1	1.8	2.3	35	10	PTB08ATEX3041/04	0.825	360
K11R 250 M6 Ex e IIC	33.0	320.0	985	92.0	91.5	90.0	0.86	63	5.7	2.1	1.7	2.4	30	9	IBEXU99ATEX1131/13	1.28	475
K11R 280 S6 Ex e IIC	40.0	386.0	990	93.9	93.5	92.5	0.86		1.9	1.8	2.5				2.63	715	
K11R 280 M6 Ex e IIC	46.0	444.0	990	94.0	93.5	92.5	0.88		1.9	1.6	2.5				3.33	810	
K11R 315 S6 Ex e IIC	64.0	619.0	988	94.5	94.0	93.5	0.90..0.88	116	7.0	2.2	1.8	2.5	28	8	PTB08ATEX3044/01	3.33	840
K11R 315 M6 Ex e IIC	76.0	732.0	992	95.2	94.6	93.0	0.88	136	6.9	1.6	1.3	2.5	40	15	IBEXU99ATEX1137/20	6.00	1080
K11R 315 MY6 Ex e IIC	85.0	820.0	990	95.2	94.5	94.0	0.87		1.6	1.4	2.5				6.00	1080	
K11R 315 L6 Ex e IIC	95	921.0	985						2.0	1.4	2.3				6.67	1250	
K11R 315 LX6 Ex e IIC	110	1061.0	990						2.0	1.4	2.3				8.60	1460	
K12R 355 M6 Ex e IIC	125	1202.0	993						1.5	1.0	2.5				8.20	1650	
K12R 355 MX6 Ex e IIC	160	1539.0	993						1.5	1.0	2.5				10.10	2100	
K12R 355 L6 Ex e IIC	200	1923.0	993						1.5	1.0	2.5				14.00	2400	

Synchronous speed 750 rpm - 8-pole version																	
KPER 80 K8 Ex e IIC																0.00130	10.5
KPER 80 G8 Ex e IIC	0.25	3.6	655..680	55			0.70..0.62	1	2.8	2.3	2.2	2.4	70	60	PTB 98 ATEX 3311	0.00175	12.0
KPER 90 S8 Ex e IIC																0.00300	15.0
KPER 90 L8 Ex e IIC																0.00375	18.0
KPER 100 L8 Ex e IIC	0.65	8.9	690..705	66			0.67..0.60	2.25	2.9	1.5	1.5	1.8	70	60	PTB 98 ATEX 3313	0.00625	23.0
KPER 100 LX8 Ex e IIC	0.95	12.9	700..710	74			0.72..0.64	2.75	4.1	2.0	2.0	2.5	70	60	PTB 98 ATEX 3313	0.00900	28.0
KPER 112 M8 Ex e IIC	1.3	17.7	690..710	75			0.70..0.61	3.9	4.1	1.8	1.7	1.9	60	50	PTB 98 ATEX 3314	0.01225	33.5
K11R 132 S8 Ex e IIC	1.9	26.0	700	76.2	76.0	74.0	0.75	5	3.8	1.6	1.6	2.2	35	30	PTB08ATEX3037/07	0.01800	49
K11R 132 M8 Ex e IIC	2.6	35.0	705	78.5	79.0	76.0	0.78..0.71	6.6	4.4	1.8	1.7	2.6	30	27	PTB08ATEX3037/08	0.0230	57
K11R 160 M8 Ex e IIC	3.5	46.0	720	80.0	80.0	76.5	0.76..0.70	8.8	4.2	1.8	1.7	2.4	45	40	PTB08ATEX3038/08	0.0430	80
K11R 160 MX8 Ex e IIC	4.8	64.0	720	81.5	80.5	78.0	0.76..0.70	11.8	4.4	1.9	1.8	2.4	45	40	PTB08ATEX3038/09	0.0530	90
K11R 160 L8 Ex e IIC	6.6	86.0	730	84.0	82.5	79.5	0.76..0.68	16.3	4.7	2.1	1.9	2.7	35	29	PTB08ATEX3038/10	0.113	122
K11R 180 L8 Ex e IIC	9.7	128.0	725	85.0	84.0	81.0	0.77..0.69	22.5	5.0	2.3	2.0	2.6	40	10	PTB08ATEX3039/05	0.145	140
K11R 200 L8 Ex e IIC	13.2	173.0	730	86.5	85.5	82.5	0.72		2.3	2.1	2.9				0.228	195	
K11R 225 S8 Ex e IIC	16.5	216.0	730	88.5	88.0	85.5	0.81		2.2	1.9	2.8				0.440	275	
K11R 225 M8 Ex e IIC	20.0	260.0	735	90.5	90.0	89.0	0.81		2.0	1.7	2.2				0.825	360	
K11R 250 M8 Ex e IIC	27.0	350.0	737	90.5	90.0	88.0	0.81..0.77	55	5.9	2.3	1.7	2.3	25	14	IBEXU99ATEX1131/14	1.350	472
K11R 280 S8 Ex e IIC	33.0	425.0	742	93.5	93.0	91.5	0.78		2.0	1.8	2.4				2.63	700	
K11R 280 M8 Ex e IIC	40.0	516.0	740	93.8	93.5	92.0	0.79		2.0	1.8	2.4				3.33	805	
K11R 315 S8 Ex e IIC	50	645.0	740	94.0	93.5	92.5	0.80		1.7	1.6	2.1				3.33	850	
K11R 315 M8 Ex e IIC	68	878.0	740	94.0	93.5	92.5	0.80		2.1	1.9	2.6				3.60	880	
K11R 315 MY8 Ex e IIC	80	1030.0	742	94.5	93.5	93.0	0.81..0.77	160	6.2	1.4	1.2	2.3	30	11	IBEXU99ATEX1137/26	6.00	1080
K11R 315 L8 Ex e IIC	95	1221.0	743						1.7	1.5	2.7				6.76	1290	
K11R 315 LX8 Ex e IIC	115	1484.0	740						1.8	1.7	2.2				8.71	1430	
K12R 355 M8 Ex e IIC	140	1807.0	740						1.5	1.1	2.5				9.50	1600	
K12R 355 MX8 Ex e IIC	180	2323.0	740						1.5	1.1	2.5				11.60	2100	
K12R 355 L8 Ex e IIC	210	2710.0	740						1.5	1.1	2.5				15.80	2400	

Optionally in dust-protected version, protection type: Protection by enclosure “tb” to EN 60079-31
for operation in Zone 21 (IBExU 02ATEX 1019 for series K1.R), degree of protection IP 65, double marking on rating plate.
Other voltages and frequencies upon request. Changes are possible for motors which are not yet certified.

Three-phase motors with squirrel-cage rotor

Type of explosion protection – Increased safety „e“ („eb“)

for operation in Zone 1 according to EN 60079-7

according to VIK Recommendation 1, Three-Phase Asynchronous Motors – Technical Requirements 03.2011

for rated voltage, temperature classes T1, T2 and T3
with surface cooling, duty type S1, continuous duty
thermal class F, degree of protection IP 55, 50 Hz

Motor selection data													Design point 400 V, 50 Hz					
Type	Temperature class	P _B	M _B	n _B	η _B			cosφ _B	I _B	I _A /I _B	M _A /M _B	M _S /M _B	M _K /M _B	t _E -time		ATEX no.	J	m
		kW	Nm	rpm	100%	75%	50%	-	400 V	-	-	-	-	T2	T3		kgm ²	kg
Synchronous speed 3000 rpm – 2-pole version																		
K11R 315 S2 Ex e IIC	T1-T3	68	218	2975	95.0	94.5	93.5	0.90	116	7.5	1.8	1.6	2.3	28	11	PTB08ATEX3044/02	1.44	850
K11R 315 S2 Ex e IIC	T1-T3	95		2960				0.89	163	5.8	1.4	1.3	1.8	18		IBExU99ATEX1137/02	1.44	850
K11R 315 S2G Ex e IIC	T1-T3	68	218	2974	94.3	87.0	92.0	0.90	116	7.8	1.5	1.3	2.1	24	9	IBExU99ATEX1137/39	1.44	850
K11R 315 M2 Ex e IIC	T1-T3	80	257	2975	95.3	94.7	94.0	0.90	134	7.5	1.8	1.6	2.2	29	12	PTB08ATEX3044/03	1.76	970
K11R 315 M2G Ex e IIC	T1-T3	80	257	2975	95.3	94.7	94.0	0.90	135	7.1	1.8	1.6	2.2	35	15	IBExU99ATEX1137/56	1.76	970
K11R 315 MY2 Ex e IIC	T1-T3	110	354	2970	95.0	94.5	93.5	0.92	182	7.3	1.5	1.3	3.0	26	11	PTB08ATEX3044/04	2.82	1150
K11R 315 MY2G Ex e IIC	T1-T3	110	354	2970	95.2	95.0	93.0	0.93	180	6.5	1.3	1.2	2.7	30	11	IBExU99ATEX1137/41	2.82	1150
K11R 315 L2 Ex e IIC	T1-T3	125	401	2980	95.3	95.0	93.5	0.93	205	8.0	1.5	1.3	2.8	30	12	IBExU99ATEX1137/40	3.66	1460
	T1,T2	165																
K11R 315 L2G Ex e IIC	T1-T3	125	401	2980	95.3	95.0	93.5	0.93	205	8.0	1.5	1.3	2.8				3.66	1460
	T1,T2	165																
K11R 315 LX2 Ex e IIC	T1-T3	150	480	2985	95.8	95.4	93.5	0.95	240	8.0	1.1	0.9	2.7	30	12	IBExU99ATEX1137/30	4.43	1630
	T1,T2	200																
K11R 315 LX2G Ex e IIC	T1-T3	150	480	2985	95.8	95.4	93.5	0.95	240	8.0	1.1	0.9	2.7				4.43	1630
	T1,T2	200																
K12R 355 M2G Ex e IIC	T1-T3	190	609	2980	95.0			0.91	310	8.0	1.4	1.1	2.6				4.20	2000
	T1,T2	220	704	2984	95.3			0.92	362	7.1				8		IBExU01ATEX1009/05		
K12R 355 MX2G Ex e IIC	T1-T3	220	705	2980	95.0			0.91	360	8.0	1.4	1.1	2.6				5.50	2200
	T1,T2	300																
K12R 355 L2G Ex e IIC	T1-T3	250	800	2986	95.1	95.5	95.2	0.93	406	6.4	1.3	0.7	1.9	9	6	IBExU01ATEX1009/17	9.50	2400
	T1,T2	300	960	2985	96.4			0.93	483	6.3				17		IBExU01ATEX1009/06		

Optionally in dust-protected version, protection type: Protection by enclosure "tb" to EN 60079-31
for operation in Zone 21 (IBExU 02ATEX 1019 for series K1.R), degree of protection IP 65, double marking on rating plate.
Other voltages and frequencies upon request. Changes are possible for motors which are not yet certified.

Three-phase motors with squirrel-cage rotor
Type of explosion protection – Increased safety „e“ („eb“)
for operation in Zone 1 according to EN 60079-7
according to VIK Recommendation 1, Three-Phase Asynchronous Motors – Technical Requirements 03.2011

 for rated voltage, temperature classes T1, T2 and T3
 with surface cooling, duty type S1, continuous duty
 thermal class F, degree of protection IP 55, 50 Hz

Motor selection data														Design point 400 V, 50 Hz				
Type	Temperature class	P _B kW	M _B Nm	n _B rpm	η _B (IEC/EN 60034-2)			cos φ _B	I _B A	I _A /I _B	M _A /M _B	M _S /M _B	M _K /M _B	t _E -time		ATEX no.	J kgm ²	m kg
					100%	75%	50%							T2 s	T3 s			
Synchronous speed 1500 rpm – 4-pole version																		
KPER 63 K4 Ex e IIC	T1-T3	0.12	0.8	1370	54	56	46	0.68	0.48	2.9	1.8	1.8	2.2	70	50	IBExU02ATEX1110	0.00019	4.8
KPER 63 G4 Ex e IIC	T1-T3	0.18	1.3	1360	60	59	52	0.69	0.63	3.2	1.9	1.9	2.2	35	30	IBExU02ATEX1110	0.00024	5.2
KPER 71 K4 Ex e IIC	T1-T3	0.25	1.7	1380	65	63	58	0.73	0.79	3.4	1.4	1.4	1.8	27	24	IBExU02ATEX1111	0.00040	6.8
KPR 71 KY4 Ex e IIC	T1-T3	0.37	2.5	1435	70	67	58	0.59	1.45	4.8	3.2	3.2	4.0	20	17	IBExU02ATEX1111	0.00087	9.9
KPER 80 GY4 Ex e IIC	T1-T3	0.55	3.7	1430	73	71	65	0.62	1.75	5.1	2.7	2.6	3.0	20	17	IBExU02ATEX1112	0.00107	11.7
KPR 80 KY4 Ex e IIC	T1-T3	0.75	5.0	1440	79	78	73	0.7	1.95	6.4	2.8	2.7	3.1	22	20	IBExU02ATEX1112	0.00207	14.5
KPER 90 S4 Ex e IIC	T1-T3	1.00	6.8	1410	77	78	75	0.8	2.4	5.1	2.4	2.3	2.5	19	17	IBExU02ATEX1113	0.00207	15.5
KPER 90 L4 Ex e IIC	T1-T3	1.35	9.1	1410	79	80	79	0.81	3.10	5.5	2.3	1.8	2.5	14	12	IBExU02ATEX1113	0.00260	18.0
KPER 100 L4 Ex e IIC	T1-T3	2.00	13.5	1420	80	82	80	0.8	4.65	6.0	2.8	2.6	2.9	13	11	IBExU02ATEX1114	0.00400	23.5
KPER 100 LX4 Ex e IIC	T1-T3	2.50	16.6	1440	83	83	81	0.78	5.60	6.7	2.3	2.2	2.9	12	11	IBExU02ATEX1114	0.00725	30.0
KPER 112 MX4 Ex e IIC	T1-T3	3.60	23.9	1440	85	85	84	0.82	7.70	7.6	2.6	2.5	3.0	14	12	IBExU02ATEX1115	0.0110	45.0
KPER 132 S4T Ex e IIC	T1-T3	4.40	29.5	1425	85.5	86.5	86	0.84	9.20	6.8	2.6	2.1	3.0	10	9	IBExU02ATEX1116	0.0110	47.0
K11R 132 S4 Ex e IIC	T1-T3	5.0	33	1435	84.5	84.0	83.0	0.83	10.2	6.5	2.0	1.6	2.8	15	10	PTB08ATEX3037/11	0.0150	53
K11R 132 M4 Ex e IIC	T1-T3	6.8	45	1455	87.5	87.0	86.0	0.82	13.6	6.1	2.1	1.8	2.7	29	12	PTB08ATEX3037/12	0.028	72
K11R 160 M4 Ex e IIC	T1-T3	10.0	65	1465	91.0	90.5	89.5	0.89	18	6.3	2.0	1.7	2.5	40	18	PTB08ATEX3038/17	0.078	123
K11R 160 L4 Ex e IIC	T1-T3	13.5	88	1470	90.5	90.0	88.0	0.86	25	7.7	2.5	2.0	3.0	26	9	PTB08ATEX3038/18	0.090	136
K11R 180 M4 Ex e IIC	T1-T3	15.0	97	1475	90.5	90.0	88.0	0.87	27.5	6.8	1.9	1.6	2.5	45	15	PTB08ATEX3039/08	0.138	180
	T1,T2	17.0	111	1465	90.5			0.88	31	6.0	1.7	1.4	2.3	35		PTB08ATEX3039/09		
K11R 180 L4 Ex e IIC	T1-T3	17.5	113	1475	90.5	90.0	88.0	0.85	33	7.1	2.1	1.8	2.8	25	9	PTB08ATEX3039/10	0.138	185
	T1,T2	20.0	130	1470	90.5			0.86	37	6.3	1.8	1.6	2.4	24		PTB08ATEX3039/11		
K11R 200 L4 Ex e IIC	T1-T3	24.0	155	1477	92.7	92.5	91.0	0.87	43	6.8	1.8	1.5	2.4	35	12	PTB08ATEX3040/09	0.275	270
	T1,T2	27.0	175	1470	92.5			0.88	48	6.0	1.6	1.5	2.2	30		PTB08ATEX3040/10		
K11R 225 S4 Ex e IIC	T1-T3	30.0	194	1475	93.0	92.5	92.0	0.85	55	6.1	1.6	1.4	1.9	30	14	PTB08ATEX3041/07	0.525	380
	T1,T2	33.0	214	1472	92.9			0.85	60	5.6	1.5	1.2	1.7	30		PTB08ATEX3041/08		
K12R 225 S4 Ex e IIC	T1-T3	30.0	194	1475	92.8	93.3	92.8	0.84	58	7.1	1.9	2.1	1.6	29	9	IBExU99ATEX1144/41	0.525	380
	T1,T2	33.0	213	1479	92.5	93.2	93.0	0.85	64	6.4	1.7	1.9	1.5	27		IBExU99ATEX1144/42		
K11R 225 M4 Ex e IIC	T1-T3	36.0	232	1480	94.0	93.5	92.5	0.85	65	7.4	2.2	1.7	2.3	22	7	PTB08ATEX3041/09	0.525	385
	T1,T2	40.0	259	1475	93.5			0.85	73	6.6	2.0	1.6	2.1	19		PTB08ATEX3041/10		
K11R 250 M4 Ex e IIC	T1-T3	44.0	283	1485	94.0	93.5	92.5	0.86	79	7.2	1.8	1.6	2.1	30	10	PTB08ATEX3042/05	0.95	530
	T1,T2	50.0	323	1480	94.0			0.86	90	6.3	1.7	1.5	1.9	27		PTB08ATEX3042/06		
K11R 280 S4 Ex e IIC	T1-T3	58.0	373	1485	94.2	93.7	92.5	0.84	106	7.2	1.8	1.6	2.2	40	13	PTB08ATEX3043/06	1.96	765
	T1,T2	68.0	439	1480	94.0			0.85	124	6.1	1.6	1.4	1.9	30		IBExU99ATEX1030/02		
K11R 280 M4 Ex e IIC	T1-T3	70.0	450	1485	95.0	94.5	93.5	0.84	127	7.5	2.0	1.8	2.4	35	13	PTB08ATEX3043/07	2.27	840
	T1,T2	80.0	515	1483	94.5			0.84	147	6.5	1.7	1.6	2.0	30		PTB08ATEX3043/08		
K11R 315 S4 Ex e IIC	T1-T3	84	540	1485	95.0	94.8	94.0	0.84	152	7.2	2.0	1.8	2.2	25	9	PTB08ATEX3044/05	2.27	875
	T1,T2	100.0	645	1480	95.1			0.84	183	6.0	1.7	1.6	1.9	20		IBExU99ATEX1137/15		
K11R 315 M4 Ex e IIC	T1-T3	100	643	1485	95.0	95.0	94.5	0.84	181	6.8	1.8	1.7	2.2	30	10	PTB08ATEX3044/06	2.73	1000
	T1,T2	120.0	775	1478	95.3			0.85	216	5.6	1.2	1.0	1.5	30		IBExU99ATEX1137/01		
K11R 315 MY4 Ex e IIC	T1-T3	115	738	1489	95.4	95.2	94.5	0.85	205	7.1	1.5	1.4	2.4	35	14	PTB08ATEX3044/07	4.82	1200
K11R 315 L4 Ex e IIC	T1-T3	135	865	1491	96.0	95.5	93.7	0.86	236	7.6	1.4	1.3	2.4	40	18	IBExU99ATEX1137/16	5.93	1450
	T1,T2	165																
K11R 315 LX4 Ex e IIC	T1-T3	170	1090	1490	96.0	95.5	95.0	0.85	300	7.1	1.2	1.1	2.4	45	18	IBExU99ATEX1137/35	6.82	1630
	T1,T2	200																
K12R 355 M4 Ex e IIC	T1-T3	215	1377	1491	96.6	96.0	95.0	0.85	380	8.0	1.4	1.1	2.7	30	8	IBExU01ATEX1009/01	5.60	2150
	T1,T2	245																
K12R 355 MX4 Ex e IIC	T1-T3	240	1538	1490	96.5			0.85	425	8.0	1.5	1.2	2.8				7.90	2400
	T1,T2	275																
K12R 355 L4 Ex e IIC	T1-T3	275	1758	1494	97.1	96.7	95.0	0.84	485	7.9	1.3	1.2	2.7	40	13	IBExU01ATEX1009/02	9.50	2500
	T1,T2	315																

Optionally in dust-protected version, protection type: Protection by enclosure "tb" to EN 60079-31
 for operation in Zone 21 (IBExU 02ATEX 1019 for series K1.R), degree of protection IP 65, double marking on rating plate.
 Other voltages and frequencies upon request. Changes are possible for motors which are not yet certified.

10

Three-phase motors with squirrel-cage rotor

Type of explosion protection – Increased safety „e“ („eb“)

for operation in Zone 1 according to EN 60079-7

according to VIK Recommendation 1, Three-Phase Asynchronous Motors – Technical Requirements 03.2011

for rated voltage, temperature classes T1, T2 and T3
with surface cooling, duty type S1, continuous duty
thermal class F, degree of protection IP 55, 50 Hz

Motor selection data														Design point 400 V, 50 Hz				
Type	Temperature class	P _B kW	M _B Nm	n _B rpm	η _B (IEC/EN 60034-2)			cosφ _B -	I _B A	I _A /I _B -	M _A /M _B -	M _S /M _B -	M _K /M _B -	t _E -time		ATEX no.	J kgm ²	m kg
					100%	75%	50%							T2 s	T3 s			
Synchronous speed 1000 rpm – 6-pole version																		
KPER 80 K6 Ex e IIC	T1-T3	0.37	3.9	910	60.5	60	55	0.7	1.26	3.2	1.7	1.7	1.9	32	28	IBExU02ATEX1112	0.00130	11.0
KPER 80 G6 Ex e IIC	T1-T3	0.55	5.8	910	66	64	60	0.69	1.75	3.6	2.1	2.1	2.2	26	22	IBExU02ATEX1112	0.00175	12.5
KPER 90 S6 Ex e IIC	T1-T3	0.65	6.7	925	69	68	65	0.71	1.95	3.4	1.8	1.7	1.9	35	30	IBExU02ATEX1113	0.00325	16.0
KPER 90 L6 Ex e IIC	T1-T3	0.95	9.8	925	71	72	69	0.71	2.7	3.9	2.1	2.0	2.2	27	23	IBExU02ATEX1113	0.00425	19.0
KPER 100 L6 Ex e IIC	T1-T3	1.40	14.2	940	75	75	74	0.73	3.75	4.2	2.1	2.0	2.3	24	20	IBExU02ATEX1114	0.00625	24.0
KPER 112 M6 Ex e IIC	T1-T3	1.90	19.1	950	79	80	78	0.74	4.7	5.3	2.2	2.0	2.4	21	18	IBExU02ATEX1115	0.01225	33.5
KPER 132 SX6T Ex e IIC	T1-T3	2.60	26.0	955	82.5	82	79	0.72	6.4	6.0	3.2	3.0	3.6	31	27	IBExU02ATEX1116	0.01580	50.0
K11R 132 S6 Ex e IIC	T1-T3	2.60	26	950	80.5	80.0	78.0	0.79	5.9	5.3	1.8	1.8	2.8	22	19	PTB08ATEX3037/13	0.0180	49
K11R 132 M6 Ex e IIC	T1-T3	3.50	35	960	82.9	82.5	81.0	0.82	7.4	6.3	2.0	2.0	3.0	24	21	PTB08ATEX3037/14	0.0230	53
K11R 132 MX6 Ex e IIC	T1-T3	4.80	48	963	83.5	82.5	82.0	0.83	10	5.1	1.8	1.6	2.5	30	28	PTB08ATEX3037/15	0.0430	70
K11R 160 M6 Ex e IIC	T1-T3	6.60	65	965	84.5	85.0	83.5	0.84	13.4	5.4	1.9	1.6	2.5	35	30	PTB08ATEX3038/19	0.0530	89
K11R 160 L6 Ex e IIC	T1-T3	9.7	96	970	85.0	84.5	82.0	0.84	19.6	5.8	2.2	1.9	2.7	30	13	PTB08ATEX3038/20	0.113	123
K11R 180 L6 Ex e IIC	T1-T3	13.2	129	975	89.0	89.0	87.0	0.87	24.5	6.5	2.2	2.0	2.9	50	23	PTB08ATEX3039/12	0.228	190
K11R 200 L6 Ex e IIC	T1-T3	16.5	161	977	87.5	87.0	83.5	0.82	33	6.8	2.4	2.1	3.2	28	9	PTB08ATEX3040/11	0.228	190
K11R 200 LX6 Ex e IIC	T1-T3	20.0	195	977	90.5	90.0	88.5	0.90	35.5	6.4	2.2	1.6	2.5	45	18	PTB08ATEX3040/12	0.443	265
K11R 225 M6 Ex e IIC	T1-T3	27.0	264	975	91.0	91.0	90.5	0.88	49	5.7	2.1	1.8	2.3	40	13	PTB08ATEX3041/11	0.825	360
K11R 250 M6 Ex e IIC	T1-T3	33.0	320	985	92.0	91.5	90.0	0.86	60	6.0	2.1	1.7	2.4	35	12	PTB08ATEX3042/07	1.28	475
K11R 280 S6 Ex e IIC	T1-T3	40.0	386	990	93.9	93.5	92.5	0.86	71	7.0	1.9	1.8	2.5	55	24	PTB08ATEX3043/09	2.63	715
K11R 280 M6 Ex e IIC	T1-T3	46.0	444	990	94.0	93.5	92.5	0.88	80	7.5	1.9	1.6	2.5	60	25	PTB08ATEX3043/10	3.33	810
K11R 315 S6 Ex e IIC	T1,T2	50.0	483	988	94.0	93.5	92.5	0.88	87	6.9	1.8	1.5	2.3	60		IBExU99ATEX1030/16		
	T1-T3	64.0	619	988	94.5	94.0	93.5	0.89	113	7.2	2.2	1.8	2.5	30	9	PTB08ATEX3044/08	3.33	840
K11R 315 M6 Ex e IIC	T1,T2	68.0	658	987	94.0	94.0	93.5	0.89	118	6.9	2.1	1.7	2.3	28		PTB08ATEX3044/09		
	T1-T3	76.0	732	992	95.2	94.6	93.0	0.88	131	7.2	1.6	1.3	2.5	45	17	IBExU99ATEX1137/19	6.00	1080
K11R 315 MY6 Ex e IIC	T1,T2	82	791	990	95.1	94.6	93.0	0.88	141	6.7	1.5	1.2	2.4	40		IBExU99ATEX1137/21		
	T1-T3	85.0	820	990	95.2	94.5	94.0	0.87	149	6.9	1.6	1.4	2.5	40	15	IBExU99ATEX1137/04	6.00	1080
K11R 315 L6 Ex e IIC	T1,T2	92	890	987	95.0	95.0	94.0	0.87	160	6.4	1.5	1.3	2.3	35		IBExU99ATEX1137/05		
	T1-T3	95	921	985	95.0			0.88	165	7.5	2.0	1.4	2.3				6.67	1250
K11R 315 LX6 Ex e IIC	T1-T3	110	1061	990	95.0			0.88	190	8.0	2.0	1.4	2.3				8.60	1460
	T1,T2	120																
K12R 355 M6 Ex e IIC	T1-T3	125	1202	993	96.0			0.86	220	8.0	1.5	1.0	2.5				8.20	1650
K12R 355 MX6 Ex e IIC	T1,T2	135																
	T1-T3	160	1539	993	96.0			0.85	285	8.0	1.5	1.0	2.5				10.10	2100
K12R 355 L6 Ex e IIC	T1,T2	175																
	T1-T3	200	1923	993	96.0			0.85	355	8.0	1.5	1.0	2.5				14.00	2400
	T1,T2	215																

Optionally in dust-protected version, protection type: Protection by enclosure "tb" to EN 60079-31
for operation in Zone 21 (IBExU 02ATEX 1019 for series K1.R), degree of protection IP 65, double marking on rating plate.
Other voltages and frequencies upon request. Changes are possible for motors which are not yet certified.

Three-phase motors with squirrel-cage rotor
Type of explosion protection – Increased safety „e“ („eb“)
for operation in Zone 1 according to EN 60079-7
according to VIK Recommendation 1, Three-Phase Asynchronous Motors – Technical Requirements 03.2011

for rated voltage, temperature classes T1, T2 and T3
 with surface cooling, duty type S1, continuous duty
 thermal class F, degree of protection IP 55, 50 Hz

Motor selection data													Design point 400 V, 50 Hz					
Type	Temperature class	P _B kW	M _B Nm	n _B rpm	η _B (IEC/EN 60034-2)			cosφ _B -	I _B 400 V A	I _A /I _B -	M _A /M _B -	M _S /M _B -	M _K /M _B -	t _E -time		ATEX no.	J kgm ²	m kg
					100%	75%	50%							T2 s	T3 s			
Synchronous speed 750 rpm – 8-pole version																		
KPER 80 K8 Ex e IIC	T1-T3	0.18	2.6	670	52	50	43	0.64	0.78	2.5	1.6	1.6	1.9	180	150	IBExU02ATEX1112	0.00130	10.5
KPER 80 G8 Ex e IIC	T1-T3	0.25	3.6	670	55	55	49	0.67	1	2.8	2.3	2.3	2.4	70	60	IBExU02ATEX1112	0.00175	12.0
KPER 90 S8 Ex e IIC	T1-T3	0.37	5.1	700	59	56	48	0.56	1.61	2.9	1.5	1.5	2.0	60	55	IBExU02ATEX1113	0.00300	15.0
KPER 90 L8 Ex e IIC	T1-T3	0.55	7.6	695	64	62	55	0.58	2.15	3.0	1.6	1.6	2.1	60	55	IBExU02ATEX1113	0.00375	18.0
KPER 100 L8 Ex e IIC	T1-T3	0.65	8.9	700	66	67	63	0.63	2.25	2.9	1.5	1.5	1.8	70	60	IBExU02ATEX1114	0.00625	23.0
KPER 100 LX8 Ex e IIC	T1-T3	0.95	12.9	705	74	76	72	0.68	2.75	4.1	2.0	2.0	2.5	70	60	IBExU02ATEX1114	0.00900	28.0
KPER 112 M8 Ex e IIC	T1-T3	1.3	17.7	700	75	75	72	0.67	3.9	4.1	1.7	1.7	1.9	60	50	IBExU02ATEX1115	0.01225	33.5
KPER 132 SX8T Ex e IIC	T1-T3	1.9	27.1	670	74	76.5	76	0.74	5.2	3.3	1.8	1.8	2.0	80	50	IBExU02ATEX1116	0.01580	50.0
K11R 132 S8 Ex e IIC	T1-T3	1.9	26	700	76.2	76.0	74.0	0.75	4.8	3.9	1.6	1.6	2.2	35	30	PTB08ATEX3037/16	0.01800	49
K11R 132 M8 Ex e IIC	T1-T3	2.6	35	705	78.5	79.0	76.0	0.74	6.5	4.5	1.8	1.7	2.6	30	29	PTB08ATEX3037/17	0.0230	57
K11R 160 M8 Ex e IIC	T1-T3	3.5	46	720	80.0	80.0	76.5	0.72	8.7	4.3	1.8	1.7	2.4	45	40	PTB08ATEX3038/21	0.0430	80
K11R 160 MX8 Ex e IIC	T1-T3	4.8	64	720	81.5	80.5	78.0	0.74	11.6	4.5	1.9	1.8	2.4	50	40	PTB08ATEX3038/22	0.0530	90
K11R 160 L8 Ex e IIC	T1-T3	6.6	86	730	84.0	82.5	79.5	0.73	15.6	5.0	2.1	1.9	2.7	40	35	PTB08ATEX3038/23	0.113	122
K11R 180 L8 Ex e IIC	T1-T3	9.7	128	725	85.0	84.0	81.0	0.73	22.5	5.1	2.3	2.0	2.6	40	12	PTB08ATEX3039/13	0.145	140
K11R 200 L8 Ex e IIC	T1-T3	13.2	173	730	86.5	85.5	82.5	0.72	30.5	5.6	2.3	2.1	2.9	40	13	PTB08ATEX3040/13	0.228	195
K11R 225 S8 Ex e IIC	T1-T3	16.5	216	730	88.5	88.0	85.5	0.81	33.5	6.0	2.2	1.9	2.8	50	20	PTB08ATEX3041/12	0.440	275
K11R 225 M8 Ex e IIC	T1-T3	20.0	260	735	90.5	90.0	89.0	0.81	39.5	5.3	2.0	1.7	2.2	60	25	PTB08ATEX3041/13	0.825	360
K11R 250 M8 Ex e IIC	T1-T3	27.0	350	737	90.5	90.0	88.0	0.80	53.5	5.7	2.3	1.7	2.3	40	13	PTB08ATEX3042/08	1.350	472
K11R 280 S8 Ex e IIC	T1-T3	33.0	425	742	93.5	93.0	91.5	0.78	65	6.3	2.0	1.8	2.4	70	30	PTB08ATEX3043/11	2.63	700
K11R 280 M8 Ex e IIC	T1-T3	40.0	516	740	93.8	93.5	92.0	0.79	78	6.5	2.0	1.8	2.4	75	30	PTB08ATEX3043/12	3.33	805
K11R 315 S8 Ex e IIC	T1-T3	50	645	740	94.0	93.5	92.5	0.80	96	5.9	1.7	1.6	2.1	50	18	PTB08ATEX3044/10	3.33	850
K11R 315 M8 Ex e IIC	T1-T3	68	878	740	94.0	93.5	92.5	0.80	131	6.3	2.1	1.9	2.6	35	9	PTB08ATEX3044/11	3.60	880
K11R 315 MY8 Ex e IIC	T1-T3	80	1030	742	94.5	93.5	93.0	0.80	154	6.4	1.4	1.2	2.3	30	12	IBExU99ATEX1137/25	6.00	1080
K11R 315 L8 Ex e IIC	T1-T3	95	1221	743	94.7	94.1	92.7	0.76	180	7.1	1.7	1.5	2.7	26	8	IBExU99ATEX1137/42	6.76	1290
K11R 315 LX8 Ex e IIC	T1-T3	115	1484	740	94.5			0.80	220	6.0	1.8	1.7	2.2				8.71	1430
K12R 355 M8 Ex e IIC	T1-T3	140	1807	740	95.0			0.79	270	7.5	1.5	1.1	2.5				9.50	1600
K12R 355 MX8 Ex e IIC	T1-T3	180	2323	740	95.5			0.79	350	7.5	1.5	1.1	2.5				11.60	2100
K12R 355 L8 Ex e IIC	T1-T3	210	2710	740	95.5			0.79	400	7.5	1.5	1.1	2.5				15.80	2400

Optionally in dust-protected version, protection type: Protection by enclosure "tb" to EN 60079-31
 for operation in Zone 21 (IBExU 02ATEX 1019 for series K1.R), degree of protection IP 65, double marking on rating plate.
 Other voltages and frequencies upon request. Changes are possible for motors which are not yet certified.

Three-phase motors with squirrel-cage rotor for converter-fed operation

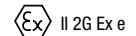

IIC T1/T2, T3 Gb

Type of explosion protection – Increased safety „e“ („eb“)

Motors for operation in Zone 1 according to EN 60079-0/EN 60079-7

with surface cooling, duty type S1, continuous duty

Degree of protection IP 55, thermal class 155, temperature class T3

Motor selection data												
Type		P	I		Torque M				EC type examination	Data-sheet	J	m
Frequency f		50 Hz	50 Hz	5 Hz	25 Hz	50 Hz	87 Hz	87 Hz	certificate			
		400 V Y ¹⁾					Y	Δ				
		kW	A	Nm	Nm	Nm	Nm	Nm			kgm ²	kg
Synchronous speed 1500 rpm – 4-pole version												
K12R	112 M4 Ex e IIC	4.55	9.4	15	25	30	17	30	PTB08ATEX3026 X		0.0150	53
K11R	132 S Ex e IIC	4.55	9.4	15	25	30	17	30	PTB08ATEX3001 X	01	0.0150	53
K11R	132 M Ex e IIC	6.1	12.9	20	40	40	20	40	PTB08ATEX3001 X	02	0.0280	72
K11R	160 M Ex e IIC	10	18.5	45	65	65	30	65	PTB 07 ATEX 3142 X	01	0.0780	123
K11R	160 L Ex e IIC	13.1	24.7	65	85	85	45	85	PTB 07 ATEX 3142 X	02	0.0900	136
K11R	180 M Ex e IIC	14.7	27.7	70	95	95	50	95	PTB 07 ATEX 3143 X	01	0.1380	180
K11R	180 L Ex e IIC	20	38	85	130	130	65	130	PTB 07 ATEX 3143 X	02	0.1380	185
K11R	200 L Ex e IIC	30	56.5	140	195	195	85	160	PTB08ATEX3027 X	01	0.2750	270
K11R	225 S Ex e IIC	35.7	66.6	200	230	230	120	230	PTB08ATEX3028 X	01	0.525	380
K11R	225 M Ex e IIC	44.3	87.5	240	285	285	156	241	PTB08ATEX3028 X	02	0.525	385
K11R	250 M Ex e IIC	55.2	101.2	310	355	355	186	306	PTB08ATEX3029 X	01	0.950	530
K11R	280 S Ex e IIC	75	138	488	486	484	278	482	PTB08ATEX3030 X	02	1.96	765
K11R	280 M Ex e IIC	90	168	586	584	582	332	565	PTB08ATEX3030 X	01	2.27	840
K11R	315 S Ex e IIC	110	195	550	650	700	350	650	PTB08ATEX3031 X		2.27	875
K11R	315 M Ex e IIC	132	230	650	760	850	425	800	PTB08ATEX3031 X		2.73	1000
Synchronous speed 1000 rpm – 6-pole version												
K12R	112 M Ex e IIC	2.6	5.9	7	26	26	15	26	PTB08ATEX3026 X		0.018	49
K11R	132 S Ex e IIC	2.6	5.9	7	26	26	15	26	PTB08ATEX3001 X		0.018	49
K11R	132 M Ex e IIC	3.5	7.4	12	35	35	20	35	PTB08ATEX3001 X		0.023	53
K11R	132 MX Ex e IIC	4.8	10.0	18	48	48	25	48	PTB08ATEX3001 X		0.043	70
K11R	160 M6 Ex e IIC	6.6	14.1	25.4	62	65	30.3	65	PTB 07 ATEX 3142 X	03	0.053	89
K11R	160 L6 Ex e IIC	9.7	19.6	50	95	95	50	95	PTB 07 ATEX 3142 X		0.113	123
K11R	180 L Ex e IIC	15.0	29.2	80	130	150	90	140	PTB 07 ATEX 3143 X	03	0.228	190
K11R	200 L Ex e IIC	16.5	33	80	150	160	80	150	PTB08ATEX3027 X		0.228	190
K11R	200 LX Ex e IIC	22	40	150	215	215	120	215	PTB08ATEX3027 X		0.443	265
K11R	225 M Ex e IIC	30	55	203	291	295	158	282	PTB08ATEX3028 X	03	0.825	360
K11R	250 M Ex e IIC	37	68	280	360	360	190	360	PTB08ATEX3029 X		1.28	475
K11R	280 S Ex e IIC	45	80	440	440	440	240	440	PTB08ATEX3030 X		2.63	715
K11R	280 M Ex e IIC	55	95	535	535	535	280	535	PTB08ATEX3030 X		3.33	810
K11R	315 S Ex e IIC	75	130	670	725	725	365	725	PTB08ATEX3031 X		3.33	840
K11R	315 M Ex e IIC	90	160	750	865	865	440	850	PTB08ATEX3031 X		6.00	1080

Temperature monitoring NAT 130 °C

¹⁾ Motor terminal voltage

Adjustment of the rated voltage of the motor by changing the number of turns of the winding is permissible within the range from 220 to 500 V.

The rated current changes reciprocally to the rated voltage.

Changes are possible for motors which are not yet certified.

Three-phase motors with squirrel-cage rotor for converter-fed operation

II 2G Ex e IIC T1/T2, T3 Gb

Type of explosion protection – Increased safety „e“ („eb“)

Motors for operation in Zone 1 according to EN 60079-0/EN 60079-7

with surface cooling, duty type S1, continuous duty
 Degree of protection IP 55, thermal class 155, temperature class T3
 max. converter input voltage 500 V

Converter parameters

In conjunction with the aforementioned monitoring device, the following converter parameters must be set and observed during operation:

Minimum pulse frequency:	3 kHz
Short-time current limit:	1.5 *I _N
Maximum overload time:	60 s
Minimum frequency f _{min} :	5 Hz
Maximum frequency f _{max} :	87 Hz

Permissible duration of operation below f_{min}: 60 s
 The maximum overload time and the permissible duration of operation below f_{min} refer to a time interval of 10 min.
 The relationship between torque and frequency can be derived from the permissible continuous current limit.

Special conditions

Motor operation in groups is not permissible.
 Motors of this type must only be operated on converters which guarantee the aforementioned converter parameters. The rated current of the frequency converter must not exceed twice the motor rated current. The current monitoring of the frequency converter must detect the effective value of the machine current with a tolerance of ± 5 % relative to the motor rated current. Before commissioning, it must be ensured that no converter-induced overvoltages with a peak value exceeding 1556 V occur at the machine terminals.

Rating plate example

VEM motors GmbH
D 98655 Wernigerode
0637 Made in Germany

Ex e II
II 2G T3

Th.Kl./Th.cl. 155 (F/B)
IP 55 53 kg

3 ~Mot.Nr./N^e 16-1507/0001 K11R 132 S4 Exe II T3 TWS VIK HW

Y						Δ					
Hz	Nm	kW	min-1/r.p.m.	V	A	Nm	kW	min-1/r.p.m.	V	A	
5	15	0,186	118	40	5,7	15	0,186	118	23	9,9	
25	25	1,855	707	200	8,1	25	1,855	707	115	14	
50	30	4,551	1444	400	9,4	30	4,551	1444	230	16,3	
87	17	4,46	2493	400	9,3	30	8,016	2554	400	16,5	

Prof./Test 19.03.2008 Beschein./Certif. PTB08ATEX3001X/01
 IM B3 DIN EN 60034-1

Fett/Grease

DE 6208 ZZ C3 DIN 625 cm ³	h	NAT 130 °C
NE 6207 ZZ C3 DIN 625 cm ³		

Three-phase motors with squirrel-cage rotor for converter-fed operation
Type of explosion protection – Increased safety „e“ („eb“)
Motors for operation in Zone 1 according to EN 60079-0/EN 60079-7

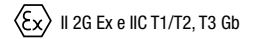

with surface cooling, duty type S1, continuous duty
 Degree of protection IP 55, thermal class 155, temperature class T3
 max. converter input voltage 500 V

Setting parameters for the continuous current limit of the frequency converter between 5 and 87 Hz:

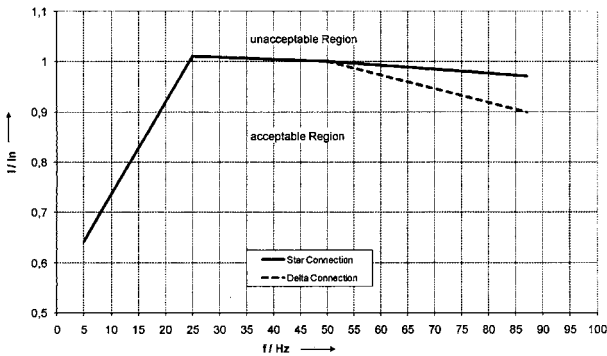

K11R 180 M2 Ex e IIC T3, PTB07ATEX 3043 X/05

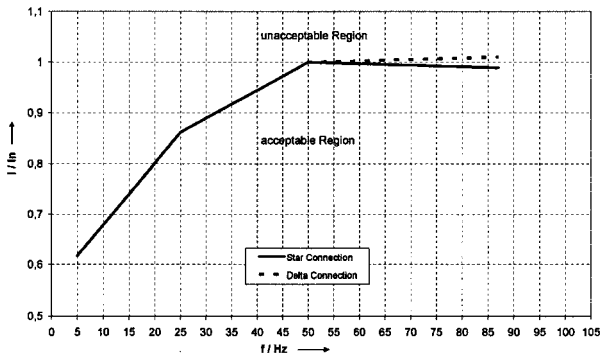

K11R 132 S4 Ex e IIC T3, PTB08ATEX 3001 X/01

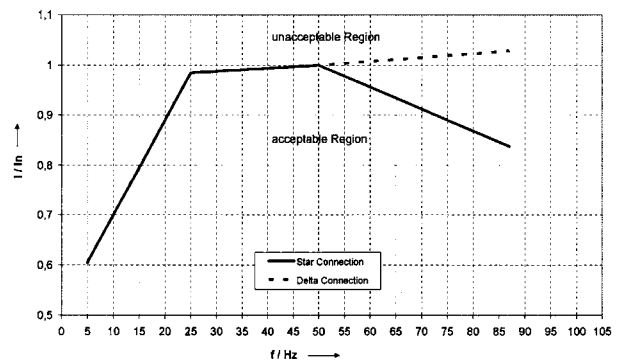

K11R 132 M4 Ex e IIC T3, PTB08ATEX 3001 X/02

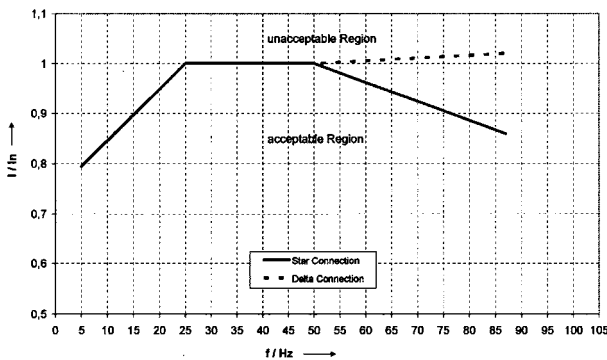

K11R 160 M4 Ex e IIC T3, PTB07ATEX 3342 X/01

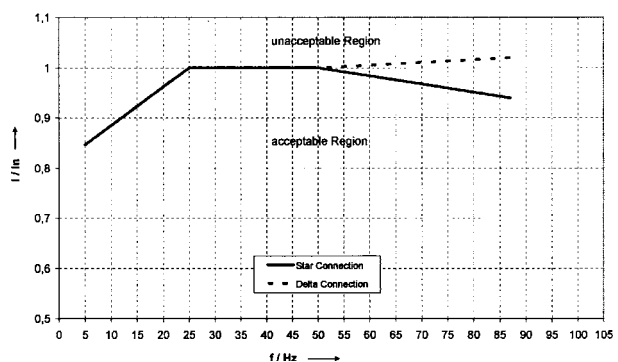

K11R 160 L4 Ex e IIC T3, PTB07ATEX 3342 X/02

Three-phase motors with squirrel-cage rotor for converter-fed operation
Type of explosion protection – Increased safety „e“ („eb“)
Motors for operation in Zone 1 according to EN 60079-0/EN 60079-7

II 2G Ex e IIC T1/T2, T3 Gb

with surface cooling, duty type S1, continuous duty
 Degree of protection IP 55, thermal class 155, temperature class T3
 max. converter input voltage 500 V

Setting parameters for the continuous current limit of the frequency converter between 5 and 87 Hz:

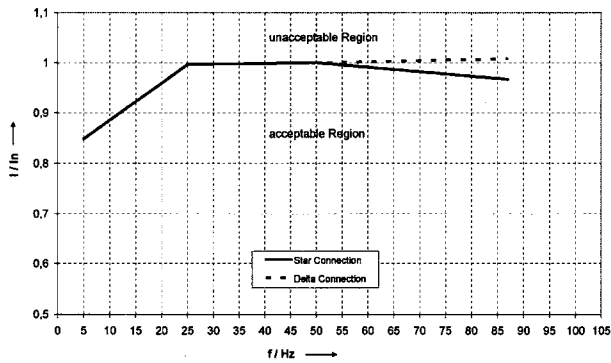

K11R 180 M4 Ex e IIC T3, PTB07ATEX 3143 X/01

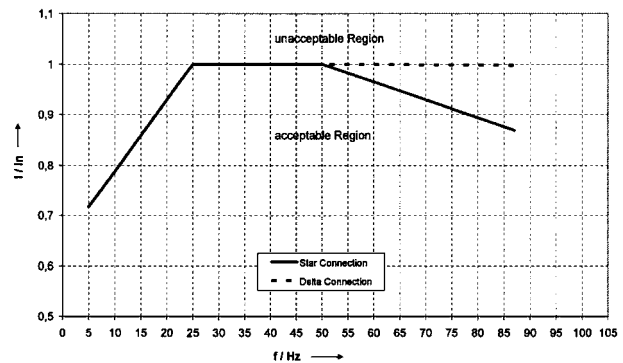

K11R 180 L4 Ex e IIC T3, PTB07ATEX 3143 X/02

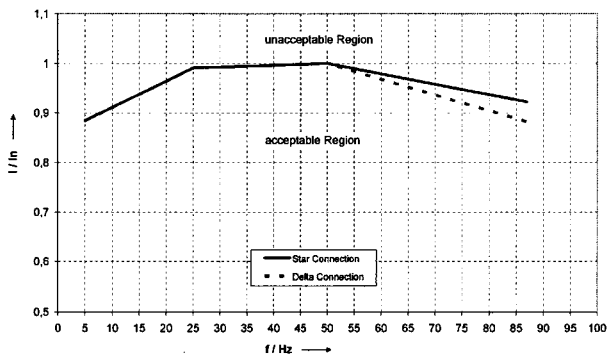

K11R 200 L4 Ex e IIC T3, PTB08ATEX 3027 X/01

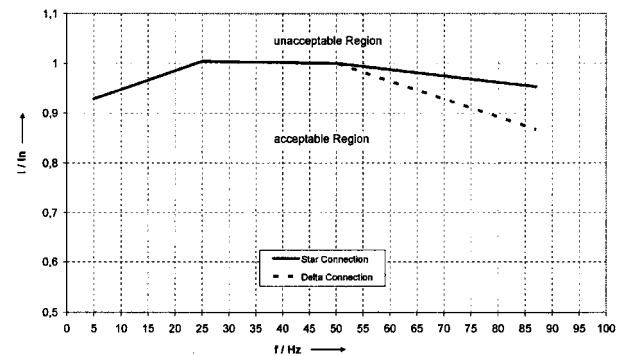

K11R 225 S4 Ex e IIC T3, PTB08ATEX 3028 X/01

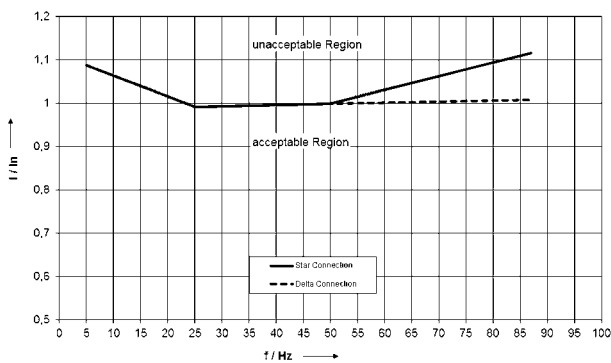

K11R 225 M4 Ex e IIC T3, PTB08ATEX 3028 X/02

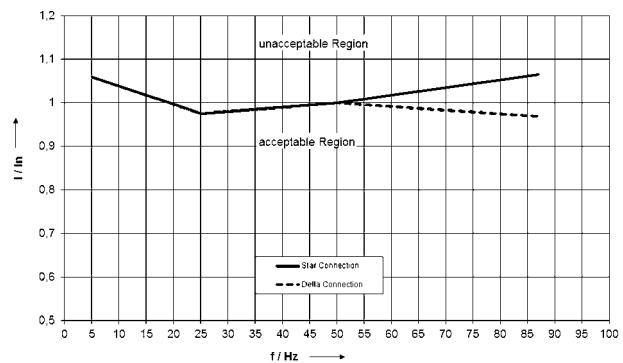

K11R 250 M4 Ex e IIC T3, PTB08ATEX 3029 X/01

Three-phase motors with squirrel-cage rotor for converter-fed operation
Type of explosion protection – Increased safety „e“ („eb“)
Motors for operation in Zone 1 according to EN 60079-0/EN 60079-7



with surface cooling, duty type S1, continuous duty
 Degree of protection IP 55, thermal class 155, temperature class T3
 max. converter input voltage 500 V

Setting parameters for the continuous current limit of the frequency converter between 5 and 87 Hz:

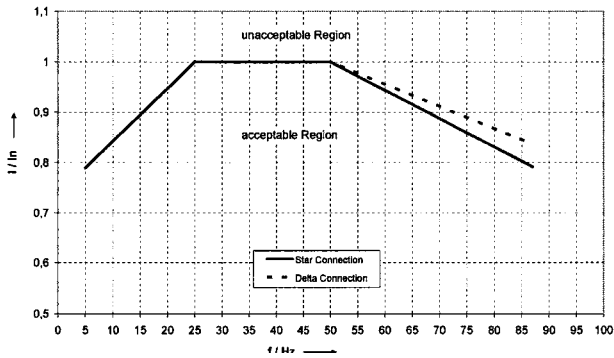

K11R 280 S4 Ex e IIC T3, PTB08ATEX 3030 X/02

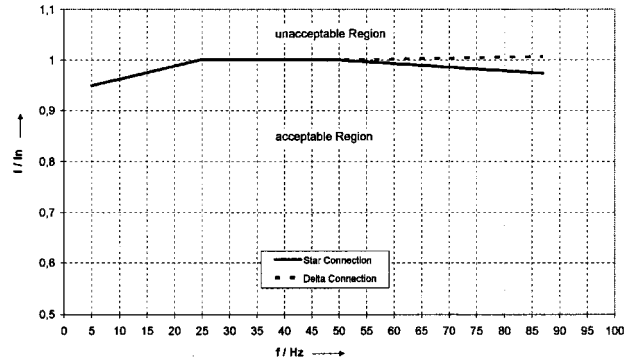

K11R 280 M4 Ex e IIC T3, PTB08ATEX 3030 X/01

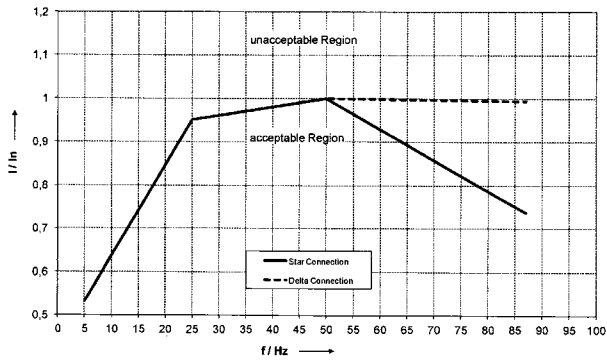

K11R 160 L6 Ex e IIC T3, PTB07ATEX 3142 X/03

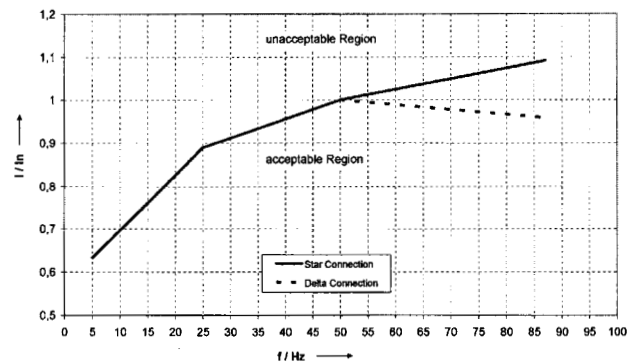

K11R 180 L6 Ex e IIC T3, PTB07ATEX 3143 X/03

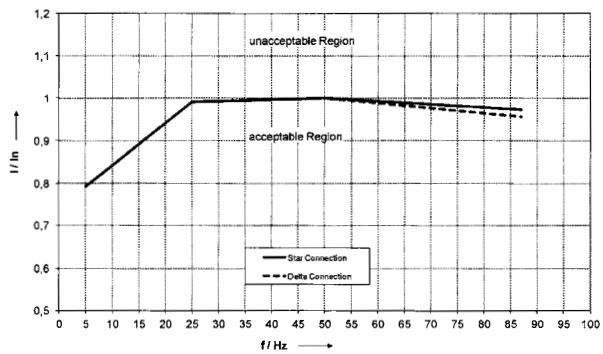

K11R 225 M6 Ex e IIC T3, PTB08ATEX 3028 X/03

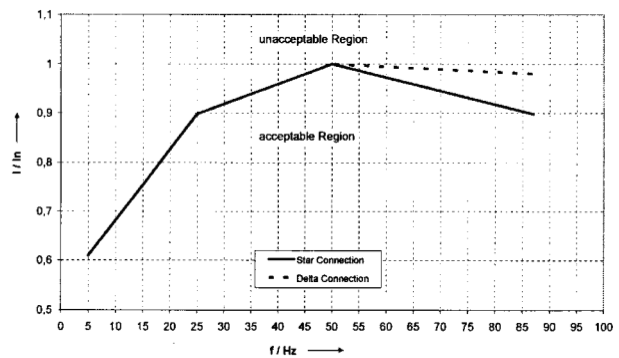

K11R 180 L8 Ex e IIC T3, PTB07ATEX 3043 X/04

Bearings

Motors in explosion-protected design

Type of explosion protection – Increased safety „e“ („eb“), Premium Efficiency IE3

Standard bearings

Type	Basic version											With relubrication device						
	Type of construction	D-end (DS)					N-end (NS)				Figure DS NS	D-end (DS)			N-end (NS)		Figure DS NS	Fixed bearing
		Anti-friction bearing					Anti-friction bearing					Anti-friction bearing			Anti-friction bearing			
	Felt ring	V-ring	Y-ring	Wave spring	Disc spring	Felt ring	V-ring	Y-ring	Wave spring		V-ring	Y-ring	Pressure springs	V-ring	Y-ring			
IE3-KPER 63 G2, 4 Ex e IIC	6201 2Z C3	11x19x4	-	-	-	6201 2Z C3	12x25x1	-	-	32 1 2	-	-	-	-	-	-	-	without
IE3-KPR 63 G4, KY2 Ex e IIC	6202 2Z C3	14x21x4	-	-	-	6202 2Z C3	15x28x1	-	-	35 1 2	-	-	-	-	-	-	-	without
IE3-KPER 71 G2 Ex e IIC	6202 2Z C3	14x21x4	-	-	-	6202 2Z C3	15x28x1	-	-	35 1 2	-	-	-	-	-	-	-	without
IE3-KPR 71 G4 Ex e IIC	6202 2Z C3	19x26x4	-	-	-	6202 2Z C3	15x28x1	-	-	47 1 2	-	-	-	-	-	-	-	without
IE3-KPER 80 K2 Ex e IIC	6204 2Z C3	19x26x4	-	-	-	6204 2Z C3	20x36x2	-	-	47 1 2	-	-	-	-	-	-	-	without
IE3-KPR 80 K2 Ex e IIC	6205 2Z C3	24.2x35x4	-	-	-	6205 2Z C3	25x40x2	-	-	52 1 2	-	-	-	-	-	-	-	without
IE3-KPR 80 G2, GX4 Ex e IIC	6205 2Z C3	24.2x35x4	-	-	-	6205 2Z C3	25x40x2	-	-	52 1 2	-	-	-	-	-	-	-	without
IE3-KPR 90 S2 Ex e IIC	6205 2Z C3	24.2x35x4	-	-	-	6205 2Z C3	25x40x2	-	-	52 1 2	-	-	-	-	-	-	-	without
IE3-KPR 90 S4 Ex e IIC	6205 2Z C3	24.2x35x4	-	-	-	6205 2Z C3	25x40x2	-	-	52 1 2	-	-	-	-	-	-	-	without
IE3-KPR 90 L2, 6 Ex e IIC	6205 2Z C3	24.2x35x4	-	-	-	6205 2Z C3	25x40x2	-	-	52 1 2	-	-	-	-	-	-	-	without
IE3-KPR 90 LX4 Ex e IIC	6205 2Z C3	24.2x35x4	-	-	-	6205 2Z C3	25x40x2	-	-	52 1 2	-	-	-	-	-	-	-	without
IE3-KPR 100 LX6 Ex e IIC	6206 2ZN C3	29x40x4	-	-	-	6206 2ZN C3	30x50x2	-	-	62 1 2	-	-	-	-	-	-	-	without
IE3-KPR 100 L2 Ex e IIC	6206 2Z C3	29x40x4	-	-	-	6206 2Z C3	30x50x2	-	-	62 1 2	-	-	-	-	-	-	-	without
IE3-KPR 100 L4 Ex e IIC	6206 2Z C3	29x40x4	-	-	-	6206 2Z C3	30x50x2	-	-	62 1 2	-	-	-	-	-	-	-	without
IE3-KPR 100 LZ4 Ex e IIC	6206 2Z C3	29x40x4	-	-	-	6206 2Z C3	30x50x2	-	-	62 1 2	-	-	-	-	-	-	-	without
IE3-KPER 112 MV6 Ex e IIC	6206 2ZN C3	29x40x4	-	-	-	6206 2ZN C3	30x50x2	-	-	62 1 2	-	-	-	-	-	-	-	without
IE3-KPER 112 MX2 Ex e IIC	6206 2Z C3	29x40x4	-	-	-	6206 2Z C3	30x50x2	-	-	62 1 2	-	-	-	-	-	-	-	without
IE3-KPER132S2T Ex e IIC	6208 2ZN C3	39x50x4	-	-	80	6306 2Z C3	30x50x2	-	-	3 5	-	-	-	-	-	-	-	without
IE3-K11R 132 S2, S2G Ex e II	6208 ZZ C3	-	-	RB40 80	-	6207 ZZ C3	-	-	RB35	6 12	-	-	-	-	-	-	-	without
IE3-K11R 132 SX2, SX2G Ex e II	6308 ZZ C3	-	-	RB40 90	-	6308 ZZ C3	-	-	RB40	6 12	6308 C3	-	RB40	-	6308 C3	-	RB40 13 14	N-end
IE3-K11R 160 M2, M2G Ex e II	6310 ZZ C3	-	-	RB50 110	-	6309 ZZ C3	-	-	RB45	6 12	6310 C3	-	RB45	-	6309 C3	-	RB45 13 14	N-end
IE3-K11R 160 MX2, MX2G Ex e II	6310 ZZ C3	-	-	RB50 110	-	6309 ZZ C3	-	-	RB45	6 12	6310 C3	-	RB45	-	6309 C3	-	RB45 13 14	N-end
IE3-K11R 160 L2, L2G Ex e II	6310 ZZ C3	-	-	RB50 110	-	6309 ZZ C3	-	-	RB45	6 12	6310 C3	-	RB45	-	6309 C3	-	RB45 13 14	N-end
IE3-K11R 180 M2, M2G Ex e II	6310 C3	-	50A	-	110	6310 C3	-	50A	-	6 8	6310 C3 50A	-	-	6310 C3 50A	-	13 14	N-end	
IE3-K11R 200 L 2, L2G Ex e II	6312 C3	-	60A	-	130	6310 C3	-	50A	-	6 8	6312 C3 50A	-	-	6310 C3 50A	-	13 14	N-end	
IE3-K11R 200 L 2C, L2CG Ex e II	6312 C3	-	60A	-	130	6310 C3	-	50A	-	6 8	6312 C3 50A	-	-	6310 C3 50A	-	13 14	N-end	
IE3-K11R 200 LX2, LX2G Ex e II	6312 C3	-	60A	-	130	6312 C3	-	60A	-	6 8	6312 C3 60A	-	-	6312 C3 60A	-	13 14	N-end	
IE3-K11R 225 M2, M2G Ex e II	6313 C3	-	65A	-	140	6313 C3	-	65A	-	6 8	6313 C3 65A	-	-	6313 C3 65A	-	13 14	N-end	
IE3-K11R 250 M2, M2G Ex e II	6314 C3	-	70A	-	150	6314 C3	-	70A	-	6 9	6314 C3 70A	-	-	6314 C3 70A	-	13 16	N-end	
IE3-K11R 280 S2, S2G Ex e II	6314 C3	-	70A	-	150	6314 C3	-	70A	-	6 9	6314 C3 70A	-	-	6314 C3 70A	-	13 16	N-end	
IE3-K11R 280 M2, M2G Ex e II	6316 C3	-	80A	-	170	6316 C3	-	80A	-	6 9	6316 C3 80A	-	-	6316 C3 80A	-	13 16	N-end	
IE3-K11R 315 S2, S2G Ex e II	6316 C3	-	80A	-	170	6316 C3	-	80A	-	6 9	6316 C3 80A	-	-	6316 C3 80A	-	13 16	N-end	
IE3-K11R 315 M2, M2G Ex e II											6317 C3	-	RB85	-	6317 C3	-	RB85 18 19	N-end
IE3-K11R 315 MY2, MY2G Ex e II											6317 C3	-	RB85	-	6317 C3	-	RB85 18 19	N-end
IE3-K11R 315 L2, L2G Ex e II											6317 C3	-	RB85	-	6317 C3	-	RB85 18 19	N-end
IE3-K11R 315 LX2, LX2G Ex e II											6317 C3	-	RB85	-	6317 C3	-	RB85 18 19	N-end
IE3-K12R 355 M2G Ex e II											6317 C3	-	RB85	-	6317 C3	-	RB85 18 19	N-end
IE3-K12R 355 MX2G Ex e II											6317 C3	-	RB85	-	6317 C3	-	RB85 18 19	N-end
IE3-K12R 355 L2G Ex e II											6317 C3	-	RB85	-	6317 C3	-	RB85 18 19	N-end
IE3-K42R 355 L2G Ex e IIC											6317 C3	-	RB85	-	6317 C3	-	RB85 18 19	N-end
IE3-K42R 400 M2G, MX2G, L2G Ex e IIC	IM B3										6317 C3	-	RB85	-	6317 C3	-	RB85 24 19	N-end
IE3-K42R 400 M2G, MX2G, L2G Ex e IIC	IM V1										7317B	-	RB85	-	6317 C3	-	RB85 18 26	N-end
IE3-K11R 112 M4	6207 ZZ C3	-	-	RB35 72	-	6207 ZZ C3	-	RB35	6 12	6207 C3	-	-	-	-	-	-	-	N-end
IE3-K11R 132 S4, M4 Ex e II	6308 ZZ C3	-	-	RB40 90	-	6308 ZZ C3	-	RB40	6 12	6308 C3	-	RB40	-	6308 C3	-	RB40 13 14	N-end	
IE3-K11R 160 M4, L4 Ex e II	6310 ZZ C3	-	-	RB50 110	-	6309 ZZ C3	-	RB45	6 12	6310 C3 50A	-	-	6309 C3	-	RB45 13 14	N-end		
IE3-K11R 180 M4, L4 Ex e II	6310 C3	-	50A	-	110	6310 C3	-	50A	-	6 8	6310 C3 50A	-	-	6310 C3 50A	-	13 14	N-end	
IE3-K11R 200 L4 Ex e II	6312 C3	-	60A	-	130	6312 C3	-	60A	-	6 8	6312 C3 60A	-	-	6312 C3 60A	-	13 14	N-end	
IE3-K11R 225 S4, M4 Ex e II	6314 C3	-	70A	-	150	6313 C3	-	65A	-	6 8	6314 C3 70A	-	-	6313 C3 65A	-	13 14	N-end	
IE3-K11R 250 M4 Ex e II	6316 C3	-	80A	-	170	6314 C3	-	70A	-	6 9	6316 C3 80A	-	-	6314 C3 70A	-	13 14	N-end	
IE3-K11R 280 S4, M4 Ex e II	6317 C3	-	85A	-	180	6316 C3	-	80A	-	6 9	6317 C3 85A	-	-	6316 C3 80A	-	13 14	N-end	
IE3-K11R 315 S4 Ex e II											6220 C3	-	RB100	-	6316 C3	-	RB80 18 19	N-end
IE3-K11R 315 M4, MY4, L4, LX4 Ex e II											6320 C3	-	RB100	-	6317 C3	-	RB85 18 19	N-end
IE3-K12R 355 M4, MX4, L4 Ex e II											6324 C3	-	RB120	-	6317 C3	-	RB85 18 19	N-end
IE3-K42R 355 M4, MX4, L4 Ex e II											6324 C3	-	RB120	-	6317 C3	-	RB85 18 19	N-end
IE3-K42R 400 M4, MX4, L4 Ex e II IM B3											6324 J C3	-	RB120	-	6319 C3	-	RB95 24 19	N-end
IE3-K42R 400 M4, MX4, L4 Ex e II IM V1											7324B	-	RB120	-	6319 C3	-	RB95 18 26	D-end

Motors in explosion-protected design

Type of explosion protection – Increased safety „e“ („eb“), Premium Efficiency IE3

Standard bearings

Type	Basic version										With relubrication device											
	D-end (DS)					N-end (NS)					Figure	D-end (DS)					N-end (NS)					Figure
	Anti-friction bearing					Anti-friction bearing						Anti-friction bearing					Anti-friction bearing					
Type of construction	V-ring	Y-ring	Wave spring	Disc spring		V-ring	Y-ring	DS	NS		V-ring	Y-ring	Pressure springs		V-ring	Y-ring	DS	NS	Fixed bearing			
IE3-K11R 132 S6 Ex e II	6208 ZZ C3	-	RB40	80	-	6207 ZZ C3	-	RB35	6	12	6208 C3	-	RB40	-	-	-	-	-	-	N-end		
IE3-K11R 132 M6, MX6 Ex e II	6308 ZZ C3	-	RB40	90	-	6308 ZZ C3	-	RB40	6	12	6308 C3	-	RB40	-	6308 C3	-	RB40	13	14	N-end		
IE3-K11R 160 M6, L6 Ex e II	6310 ZZ C3	-	RB50	110	-	6309 ZZ C3	-	RB45	6	12	6310 C3	50A	-	-	6309 C3	-	RB45	13	14	N-end		
IE3-K11R 180 L6 Ex e II	6310 C3	50A	-	110	-	6310 C3	50A	-	6	8	6310 C3	50A	-	-	6310 C3	50A	-	13	14	N-end		
IE3-K11R 200 L6 Ex e II	6312 C3	60A	-	-	130	6310 C3	50A	-	6	8	6312 C3	60A	-	-	6310 C3	50A	-	13	14	N-end		
IE3-K11R 200 LX6 Ex e II	6312 C3	60A	-	-	130	6312 C3	60A	-	6	8	6312 C3	60A	-	-	6312 C3	60A	-	13	14	N-end		
IE3-K11R 225 M6 Ex e II	6314 C3	70A	-	-	150	6313 C3	65A	-	6	8	6314 C3	70A	-	-	6313 C3	65A	-	13	14	N-end		
IE3-K11R 250 M6 Ex e II	6316 C3	80A	-	-	170	6314 C3	70A	-	6	9	6316 C3	80A	-	-	6314 C3	70A	-	13	14	N-end		
IE3-K11R 280 S6, M6 Ex e II	6317 C3	85A	-	-	180	6316 C3	80A	-	6	9	6317 C3	85A	-	-	6316 C3	80A	-	13	14	N-end		
IE3-K11R 315 S6, M6, MY6, L6, LX6 Ex e II			Relubrication device as standard								6320 C3	-	RB100	-	6317 C3	-	RB85	18	19	N-end		
IE3-K12R 355 M6, MX6, L6 Ex e II			Relubrication device as standard								6324 C3	-	RB120	-	6317 C3	-	RB85	18	19	N-end		
IE3-K42R 355 M6, MX6, L6 Ex e II			Relubrication device as standard								6324 C3	-	RB120	-	6317 C3	-	RB85	18	19	N-end		
IE3-K42R 400 M6, MX6, L6 Ex e II	IM B3		Relubrication device as standard								6324 J C3	-	RB120	-	6319 C3	-	RB95	24	19	N-end		
IE3-K42R 400 M6, MX6, L6 Ex e II	IM V1		Relubrication device as standard								7324B	-	RB120	-	6319 C3	-	RB95	18	26	D-end		
IE3-K11R 132 S8 Ex e II	6208 ZZ C3	-	RB40	80	-	6207 ZZ C3	-	RB35	6	12	6208 C3	-	RB40	-	-	-	-	-	-	N-end		
IE3-K11R 132 M8 Ex e II	6308 ZZ C3	-	RB40	90	-	6308 ZZ C3	-	RB40	6	12	6308 C3	-	RB40	-	6308 C3	-	RB40	13	14	N-end		
IE3-K11R 160 M8 Ex e II	6309 ZZ C3	-	RB45	100	-	6308 ZZ C3	-	RB40	6	12	6309 C3	-	RB45	-	-	-	-	-	-	N-end		
IE3-K11R 160 MX8, L8 Ex e II	6310 ZZ C3	-	RB50	110	-	6309 ZZ C3	-	RB45	6	12	6310 C3	50A	-	-	6309 C3	-	RB45	13	14	N-end		
IE3-K11R 180 L8 Ex e II	6310 C3	50A	-	110	-	6310 C3	50A	-	6	8	6310 C3	50A	-	-	6310 C3	50A	-	13	14	N-end		
IE3-K11R 200 L8 Ex e II	6312 C3	60A	-	-	130	6310 C3	50A	-	6	8	6312 C3	60A	-	-	6310 C3	50A	-	13	14	N-end		
IE3-K11R 225 S8 Ex e II	6313 C3	65A	-	-	140	6312 C3	60A	-	6	8	6313 C3	65A	-	-	6312 C3	60A	-	13	14	N-end		
IE3-K11R 225 M8 Ex e II	6314 C3	70A	-	-	150	6313 C3	65A	-	6	8	6314 C3	70A	-	-	6313 C3	65A	-	13	14	N-end		
IE3-K11R 250 M8 Ex e II	6316 C3	80A	-	-	170	6314 C3	70A	-	6	9	6316 C3	80A	-	-	6314 C3	70A	-	13	14	N-end		
IE3-K11R 280 S8 Ex e II	6316 C3	80A	-	-	170	6314 C3	70A	-	6	9	6316 C3	80A	-	-	6314 C3	70A	-	13	14	N-end		
IE3-K11R 280 M8 Ex e II	6317 C3	85A	-	-	180	6316 C3	80A	-	6	9	6317 C3	85A	-	-	6316 C3	80A	-	13	14	N-end		
IE3-K11R 315 S8, M8 Ex e II	6317 C3	85A	-	-	180	6316 C3	80A	-	6	9	6317 C3	85A	-	-	6316 C3	80A	-	13	14	N-end		
IE3-K11R 315 MY8, L8, LX8 Ex e II			Relubrication device as standard								6320 C3	RB100	-	-	6317 C3	-	RB85	18	19	N-end		
IE3-K12R 355 M8, MX8, L8 Ex e II			Relubrication device as standard								6324 C3	RB120	-	-	6317 C3	-	RB85	18	19	N-end		
IE3-K42R 355 M8, MX8, L8 Ex e II			Relubrication device as standard								6324 C3	RB120	-	-	6317 C3	-	RB85	18	19	N-end		
IE3-K42R 400 M8, MX8, L8 Ex e II	IM B3		Relubrication device as standard								6324 J C3	-	RB120	-	6319 C3	-	RB95	24	19	N-end		
IE3-K42R 400 M8, MX8, L8 Ex e II	IM V1		Relubrication device as standard								7324B	¹⁾	RB120	-	6319 C3	-	RB95	18	26	D-end		

¹⁾ Pressure springs, at N-end for IM V1

Motors in explosion-protected design

Type of explosion protection – Increased safety „e“ („eb“), Premium Efficiency IE3

Reinforced bearings

Type	Type of construction	Without relubrication device					With relubrication device												
		D-end (DS)		N-end (NS)		Figure	D-end (DS)		N-end (NS)			Figure							
		Anti-friction bearing		Anti-friction bearing			Anti-friction bearing		Anti-friction bearing		DS	NS	Fixed bearing						
V-ring	Y-ring	V-ring	Y-ring	DS NS	V-ring	Y-ring	Pressure springs	V-ring	Y-ring	DS	NS	Fixed bearing							
IE3-K11R 132 S2, S2G Ex e II		NU 208 E	-	RB40	6207 ZZ C3	-	RB35	7	9	-	-	-	-	-	-	-			
IE3-K11R 132 SX2, SX2G Ex e II		NU 308 E	-	RB40	6308 ZZ C3	-	RB40	7	9	NU 308 E	-	RB40	-	6308 C3	-	RB40	15	16	N-end
IE3-K11R 160 M2, M2G Ex e II		NU 310 E	-	RB50	6309 ZZ C3	-	RB45	7	9	NU 310 E	-	RB45	-	6309 C3	-	RB45	15	16	N-end
IE3-K11R 160 MX2, MX2G Ex e II		NU 310 E	-	RB50	6309 ZZ C3	-	RB45	7	9	NU 310 E	-	RB45	-	6309 C3	-	RB45	15	16	N-end
IE3-K11R 160 L2, L2G Ex e II		NU 310 E	-	RB50	6309 ZZ C3	-	RB45	7	9	NU 310 E	-	RB45	-	6309 C3	-	RB45	15	16	N-end
IE3-K11R 180 M2, M2G Ex e II		NU 310 E	50A	-	6310 C3	50A	-	7	9	NU 310 E	50A	-	-	6310 C3	50A	-	15	16	N-end
IE3-K11R 200L 2, L2G Ex e II		NU 312 E	60A	-	6310 C3	50A	-	7	9	NU 312 E	50A	-	-	6310 C3	50A	-	15	16	N-end
IE3-K11R 200L 2C, L2CG Ex e II		NU 312 E	60A	-	6310 C3	50A	-	7	9	NU 312 E	50A	-	-	6310 C3	50A	-	15	16	N-end
IE3-K11R 200 LX2, LX2G Ex e II		NU 312 E	60A	-	6312 C3	60A	-	7	9	NU 312 E	60A	-	-	6312 C3	60A	-	15	16	N-end
IE3-K11R 225 M2, M2G Ex e II		NU 313 E	65A	-	6313 C3	65A	-	7	9	NU 313 E	65A	-	-	6313 C3	65A	-	15	16	N-end
IE3-K11R 250 M2, M2G Ex e II		NU 314 E	70A	-	6314 C3	70A	-	7	9	NU 314 E	70A	-	-	6314 C3	70A	-	15	16	N-end
IE3-K11R 280 S2, S2G Ex e II		NU 314 E	70A	-	6314 C3	70A	-	7	9	NU 314 E	70A	-	-	6314 C3	70A	-	15	16	N-end
IE3-K11R 280 M2, M2G Ex e II		NU 316 E	80A	-	6316 C3	80A	-	7	9	NU 316 E	80A	-	-	6316 C3	80A	-	15	16	N-end
IE3-K11R 315 S2, S2G Ex e II		NU 316 E	80A	-	6316 C3	80A	-	7	9	NU 316 E	80A	-	-	6316 C3	80A	-	15	16	N-end
IE3-K11R 315 M2, M2G Ex e II										NU 317 E	-	RB85	-	6317 C3	-	RB85	20	19	N-end
IE3-K11R 315 MY2, MY2G Ex e II										NU 317 E	-	RB85	-	6317 C3	-	RB85	20	19	N-end
IE3-K11R 315 L2, L2G Ex e II										NU 317 E	-	RB85	-	6317 C3	-	RB85	20	19	N-end
IE3-K11R 315 LX2, LX2G Ex e II										NU 317 E	-	RB85	-	6317 C3	-	RB85	20	19	N-end
IE3-K12R 355 M2G Ex e II										NU 317 E	-	RB85	-	6317 C3	-	RB85	20	19	N-end
IE3-K12R 355 MX2G Ex e II										NU 317 E	-	RB85	-	6317 C3	-	RB85	20	19	N-end
IE3-K12R 355 L2G Ex e II										NU 317 E	-	RB85	-	6317 C3	-	RB85	20	19	N-end
IE3-K42R 355 L2G Ex e IIC										NU 317 E	-	RB85	-	6317 C3	-	RB85	20	19	N-end
IE3-K42R 400 M2G, MX2G, L2G Ex e IIC	IM B3									NU 317 E	-	RB85	-	6317 C3	-	RB85	20	19	N-end
IE3-K42R 400 M2G, MX2G, L2G Ex e IIC	IM V1									NU218E	-	RB85	-	6317 C3	-	RB85	25	26	N-end
IE3-W41R 112 M4		NU 207 E	-	-	6207 ZZ C3	-	7	9		-	-	-	-	-	-	-			N-end
IE3-K11R 132 S4, M4 Ex e II		NU 308 E	-	RB40	6308 ZZ C3	-	RB40	7	9	NU 308 E	-	RB40	-	6308 C3	-	RB40	15	16	N-end
IE3-K11R 160 M4, L4 Ex e II		NU 310 E	-	RB50	6309 ZZ C3	-	RB45	7	9	NU 310 E	50A	-	-	6309 C3	-	RB45	15	16	N-end
IE3-K11R 180 M4, L4 Ex e II		NU 310 E	50A	-	6310 C3	50A	-	7	9	NU 310 E	50A	-	-	6310 C3	50A	-	15	16	N-end
IE3-K11R 200 L4 Ex e II		NU 312 E	60A	-	6312 C3	60A	-	7	9	NU 312 E	60A	-	-	6312 C3	60A	-	15	16	N-end
IE3-K11R 225 S4, M4 Ex e II		NU 314 E	70A	-	6313 C3	65A	-	7	9	NU 314 E	70A	-	-	6313 C3	65A	-	15	16	N-end
IE3-K11R 250 M4 Ex e II		NU 316 E	80A	-	6314 C3	70A	-	7	9	NU 316 E	80A	-	-	6314 C3	70A	-	15	16	N-end
IE3-K11R 280 S4, M4 Ex e II		NU 317 E	-	RB85	6316 C3	80A	-	7	9	NU 317 E	85A	-	-	6316 C3	80A	-	15	16	N-end
IE3-K11R 315 S4 Ex e II										NU 2220 E	-	RB100	-	6316 C3	-	RB80	20	19	N-end
IE3-K11R 315 M4, MY4, L4, LX4 Ex e II										NU 320 E	-	RB100	-	6317 C3	-	RB85	20	19	N-end
IE3-K12R 355 M4, MX4, L4 Ex e II										NU 324 E	-	RB120	-	6317 C3	-	RB85	20	19	N-end
IE3-K42R 355 M4, MX4, L4 Ex e II										NU 324 E	-	RB120	-	6317 C3	-	RB85	20	19	N-end
IE3-K42R 400 M4, MX4, L4 Ex e II	IM B3									NU 324 E	-	RB120	-	6319 C3	-	RB95	20	19	N-end
IE3-K42R 400 M4, MX4, L4 Ex e II	IM V1									NU226	-	RB120	-	6319 C3	-	RB95	25	26	D-end
IE3-K11R 132 S6 Ex e II		NU 208 E	-	RB40	6207 ZZ C3	-	RB35	7	9	NU 308 E	-	RB40	-	-	-	-			N-end
IE3-K11R 132 M6, MX6 Ex e II		NU 308 E	-	RB40	6308 ZZ C3	-	RB40	7	9	NU 308 E	-	RB40	-	6308 C3	-	RB40	15	16	N-end
IE3-K11R 160 M6, L6 Ex e II		NU 310 E	-	RB50	6309 ZZ C3	-	RB45	7	9	NU 310 E	50A	-	-	6309 C3	-	RB45	15	16	N-end
IE3-K11R 180 L6 Ex e II		NU 310 E	50A	-	6310 C3	50A	-	7	9	NU 310 E	50A	-	-	6310 C3	50A	-	15	16	N-end
IE3-K11R 200 L6 Ex e II		NU 312 E	60A	-	6310 C3	50A	-	7	9	NU 312 E	60A	-	-	6310 C3	50A	-	15	16	N-end
IE3-K11R 200 LX6 Ex e II		NU 312 E	60A	-	6312 C3	60A	-	7	9	NU 312 E	60A	-	-	6312 C3	60A	-	15	16	N-end
IE3-K11R 225 M6 Ex e II		NU 314 E	70A	-	6313 C3	65A	-	7	9	NU 314 E	70A	-	-	6313 C3	65A	-	15	16	N-end
IE3-K11R 250 M6 Ex e II		NU 316 E	80A	-	6314 C3	70A	-	7	9	NU 316 E	80A	-	-	6314 C3	70A	-	15	16	N-end
IE3-K11R 280 S6, M6 Ex e II		NU 317 E	85A	-	6316 C3	80A	-	7	9	NU 317 E	85A	-	-	6316 C3	80A	-	15	16	N-end
IE3-K11R 315 S6, M6, MY6, L6, LX6 Ex e II										NU 320 E	-	RB100	-	6317 C3	-	RB85	20	19	N-end
IE3-K12R 355 M6, MX6, L6 Ex e II										NU 324 E	-	RB120	-	6317 C3	-	RB85	20	19	N-end
IE3-K42R 355 M6, MX6, L6 Ex e II										NU 324 E	-	RB120	-	6317 C3	-	RB85	20	19	N-end
IE3-K42R 400 M6, MX6, L6 Ex e II	IM B3									NU 324 E	-	RB120	-	6319 C3	-	RB95	20	19	N-end
IE3-K42R 400 M6, MX6, L6 Ex e II	IM V1									NU226	-	RB120	-	6319 C3	-	RB95	25	26	D-end

Motors in explosion-protected design

Type of explosion protection – Increased safety „e“ („eb“), Premium Efficiency IE3

Reinforced bearings

Type	Type of construction	Without relubrication device					With relubrication device												
		D-end (DS) Anti-friction bearing		N-end (NS) Anti-friction bearing		Figure DS NS	D-end (DS) Anti-friction bearing			N-end (NS) Anti-friction bearing			Figure						
		V-ring	Y-ring	V-ring	Y-ring		V-ring	Y-ring	Pressure springs	V-ring	Y-ring	DS	NS	Fixed bearing					
IE3-K11R 132 S8 Ex e II		NU 208 E	-	RB40	6207 ZZ C3	-	RB35	7	9	-	-	RB40	-	-	-	RB35	15	16	N-end
IE3-K11R 132 M8 Ex e II		NU 308 E	-	RB40	6308 ZZ C3	-	RB40	7	9	NU 308 E	-	RB40	-	6308 C3	-	RB40	15	16	N-end
IE3-K11R 160 M8 Ex e II		NU 309 E	-	RB45	6308 ZZ C3	-	RB45	7	9	-	-	RB45	-	-	-	RB45	15	16	N-end
IE3-K11R 160 MX8, L8 Ex e II		NU 310 E	-	RB50	6309 ZZ C3	-	RB45	7	9	NU 310 E	50A	-	-	6309 C3	-	RB45	15	16	N-end
IE3-K11R 180 L8 Ex e II		NU 310 E	50A	-	6310 C3	50A	-	7	9	NU 310 E	50A	-	-	6310 C3	50A	-	15	16	N-end
IE3-K11R 200 L8 Ex e II		NU 312 E	60A	-	6310 C3	50A	-	7	9	NU 312 E	60A	-	-	6310 C3	50A	-	15	16	N-end
IE3-K11R 225 S8 Ex e II		NU 313 E	65A	-	6312 C3	60A	-	7	9	NU 313 E	65A	-	-	6312 C3	60A	-	15	16	N-end
IE3-K11R 225 M8 Ex e II		NU 314 E	70A	-	6313 C3	65A	-	7	9	NU 314 E	70A	-	-	6313 C3	65A	-	15	16	N-end
IE3-K11R 250 M8 Ex e II		NU 316 E	80A	-	6314 C3	70A	-	7	9	NU 316 E	80A	-	-	6314 C3	70A	-	15	16	N-end
IE3-K11R 280 S8 Ex e II		NU 316 E	80A	-	6314 C3	70A	-	7	9	NU 316 E	80A	-	-	6314 C3	70A	-	15	16	N-end
IE3-K11R 280 M8 Ex e II		NU 317 E	85A	-	6316 C3	80A	-	7	9	NU 317 E	85A	-	-	6316 C3	80A	-	15	16	N-end
IE3-K11R 315 S8, M8 Ex e II		NU 317 E	85A	-	6316 C3	80A	-	7	9	NU 317 E	85A	-	-	6316 C3	80A	-	15	16	N-end
IE3-K11R 315 MY8, L8, LX8 Ex e II										NU 320 E	RB100	-	-	6317 C3	-	RB85	20	19	N-end
IE3-K12R 355 M8, MX8, L8 Ex e II										NU 324 E	RB120	-	-	6317 C3	-	RB85	20	19	N-end
IE3-K42R 355 M8, MX8, L8 Ex e II										NU 324 E	RB120	-	-	6317 C3	-	RB85	20	19	N-end
IE3-K42R 400 M8, MX8, L8 Ex e II	IM B3									NU 324 E	-	RB120	-	6319 C3	-	RB95	20	19	N-end
										7226B+									
IE3-K42R 400 M8, MX8, L8 Ex e II	IM V1									NU226	1)	RB120	-	6319 C3	-	RB95	25	26	D-end

¹⁾ Pressure springs, at N-end for IM V1

Motors in explosion-protected design

Type of explosion protection – Increased safety „e“ („eb“), High Efficiency, IE2

Reinforced bearings

Type	Without relubrication device						With relubrication device								
	D-end (DS) Anti-friction bearing		N-end (NS) Anti-friction bearing		Figure		D-end (DS) Anti-friction bearing		N-end (NS) Anti-friction bearing		Figure				
	V-ring	Y-ring	V-ring	Y-ring	DS	NS	V-ring	Y-ring	V-ring	Y-ring	DS	NS	Fixed bearing		
IE2-K11R 132 S2, S2G Ex e IIC	-	-	-	-	-	-	-	-	-	-	-	-	-	-	
IE2-K11R 132 SX2, SX2G Ex e IIC	NU 308 E	- RB40	6308 ZZ C3	- RB40	7	9	NU 308 E	- RB40	6308 C3	- RB45	15	16	N-end		
IE2-K11R 160 M2, M2G Ex e IIC	NU 310 E	- RB50	6309 ZZ C3	- RB45	7	9	NU 310 E	- RB50	6309 C3	- RB45	15	16	N-end		
IE2-K11R 160 MX2, MX2G Ex e IIC	NU 310 E	- RB50	6309 ZZ C3	- RB45	7	9	NU 310 E	- RB50	6309 C3	- RB45	15	16	N-end		
IE2-K11R 160 L2, L2G Ex e IIC	NU 310 E	- RB50	6309 ZZ C3	- RB45	7	9	NU 310 E	- RB50	6309 C3	50A	-	15	16	N-end	
IE2-K11R 180 M2, M2G Ex e IIC	NU 310 E	50A	- 6310 C3	50A	-	7	9	NU 310 E	50A	- 6310 C3	50A	-	15	16	N-end
IE2-K11R 200 L2, L2G Ex e IIC	NU 312 E	60A	- 6310 C3	50A	-	7	9	NU 312 E	60A	- 6310 C3	60A	-	15	16	N-end
IE2-K11R 200 LX2, LX2G Ex e IIC	NU 312 E	60A	- 6312 C3	60A	-	7	9	NU 312 E	60A	- 6312 C3	65A	-	15	16	N-end
IE2-K11R 225 M2, M2G Ex e IIC	NU 313 E	65A	- 6313 C3	65A	-	7	9	NU 313 E	65A	- 6313 C3	70A	-	15	16	N-end
IE2-K11R 250 M2, M2G Ex e IIC	NU 314 E	70A	- 6314 C3	70A	-	7	9	NU 314 E	70A	- 6314 C3	70A	-	15	16	N-end
IE2-K11R 280 S2, S2G Ex e IIC	NU 314 E	70A	- 6314 C3	70A	-	7	9	NU 314 E	70A	- 6314 C3	70A	-	15	16	N-end
IE2-K11R 280 M2, M2G Ex e IIC	NU 314 E	70A	- 6314 C3	70A	-	7	9	NU 314 E	70A	- 6314 C3	80A	-	15	16	N-end
IE2-K11R 315 S2, S2G Ex e IIC		Relubrication device as standard					NU 316 E	80A	- 6316 C3	80A	-	15	16	N-end	
IE2-K11R 315 M2, M2G Ex e IIC		Relubrication device as standard					NU 317 E	85A	- 6316 C3	- RB85	15	16	N-end		
IE2-K11R 315 MY2, MY2G Ex e IIC		Relubrication device as standard					NU 317 E	85A	RB85	6317 C3	- RB85	20	19	N-end	
IE2-K11R 315 L2, L2G Ex e IIC		Relubrication device as standard					NU 317 E	85A	RB85	6317 C3	- RB85	20	19	N-end	
IE2-K11R 315 L2, LX2G Ex e IIC		Relubrication device as standard					NU 317 E	85A	RB85	6317 C3	- RB85	20	19	N-end	
IE2-K12R 355 M2G Ex e IIC		Relubrication device as standard					NU 317 E	85A	RB85	6317 C3	- RB85	20	19	N-end	
IE2-K12R 355 L2G Ex e IIC		Relubrication device as standard					NU 317 E	85A	RB85	6317 C3	- RB40	20	19	N-end	
IE2-K11R 132 S4, M 4 Ex e IIC	NU 308 E	- RB40	6308 ZZ C3	- RB40	7	9	NU 308 E	- RB40	6308 C3	- RB45	15	16	N-end		
IE2-K11R 160 M4, L 4 Ex e IIC	NU 310 E	- RB50	6309 ZZ C3	- RB45	7	9	NU 310 E	- RB50	6309 C3	50A	-	15	16	N-end	
IE2-K11R 180 M4, L 4 Ex e IIC	NU 310 E	50A	- 6310 C3	50A	-	7	9	NU 310 E	50A	- 6310 C3	60A	-	15	16	N-end
IE2-K11R 200 L4 Ex e IIC	NU 312 E	60A	- 6312 C3	60A	-	7	9	NU 312 E	60A	- 6312 C3	65A	-	15	16	N-end
IE2-K11R 225 S4, M 4 Ex e IIC	NU 314 E	70A	- 6313 C3	65A	-	7	9	NU 314 E	70A	- 6313 C3	70A	-	15	16	N-end
IE2-K11R 250 M4 Ex e IIC	NU 316 E	80A	- 6314 C3	70A	-	7	9	NU 316 E	80A	- 6314 C3	80A	-	15	16	N-end
IE2-K11R 280 S4, M 4 Ex e IIC	NU 317 E	85A	- 6316 C3	80A	-	7	9	NU 317 E	85A	- 6316 C3	80A	-	15	16	N-end
IE2-K11R 315 S4 Ex e IIC	NU 317 E	85A	- 6316 C3	80A	-	7	9	NU 317 E	85A	- 6316 C3	80A	-	15	16	N-end
IE2-K11R 315 M4 Ex e IIC		Relubrication device as standard					NU 2220 E	-	RB100	6316 C3	- RB85	15	16	N-end	
IE2-K11R 315 MY4, L 4 Ex e IIC		Relubrication device as standard					NU 320 E	-	RB100	6317 C3	- RB85	20	19	N-end	
IE2-K11R 315 LX4 Ex e IIC		Relubrication device as standard					NU 320 E	-	RB100	6317 C3	- RB85	20	19	N-end	
IE2-W22R 355 M4, MX4 Ex e IIC		Relubrication device as standard					NU 324 E	-	RB120	6317 C3	- RB85	20	19	N-end	
IE2-K12R 355 L4 Ex e IIC		Relubrication device as standard					NU 324 E	-	RB120	6317 C3	- RB35	20	19	N-end	
IE2-K11R 132 S6, M 6 Ex e IIC	NU 208 E	- RB40	6207 ZZ C3	- RB35	7	9	-	-	RB40	-	-	RB40	15	16	N-end
IE2-K11R 132 MX6 Ex e IIC	NU 308 E	- RB40	6308 ZZ C3	- RB40	7	9	NU 308 E	- RB40	6308 C3	- RB40	15	16	N-end		
IE2-K11R 160 M6 Ex e IIC	NU 309 E	- RB45	6308 ZZ C3	- RB40	7	9	-	-	RB45	-	-	RB45	15	16	N-end
IE2-K11R 160 L6 Ex e IIC	NU 310 E	- RB50	6309 ZZ C3	- RB45	7	9	NU 310 E	- RB50	6309 C3	50A	-	15	16	N-end	
IE2-K11R 180 L6 Ex e IIC	NU 310 E	50A	- 6310 C3	50A	-	7	9	NU 310 E	50A	- 6310 C3	50A	-	15	16	N-end
IE2-K11R 200 L6 Ex e IIC	NU 312 E	60A	- 6310 C3	50A	-	7	9	NU 312 E	60A	- 6310 C3	60A	-	15	16	N-end
IE2-K11R 200 LX6 Ex e IIC	NU 312 E	60A	- 6312 C3	60A	-	7	9	NU 312 E	60A	- 6312 C3	65A	-	15	16	N-end
IE2-K11R 225 M6 Ex e IIC	NU 314 E	70A	- 6313 C3	65A	-	7	9	NU 314 E	70A	- 6313 C3	65A	-	15	16	N-end
IE2-K11R 250 M6 Ex e IIC	NU 314 E	70A	- 6313 C3	65A	-	7	9	NU 314 E	70A	- 6313 C3	70A	-	15	16	N-end
IE2-K11R 280 S6 Ex e IIC	NU 316 E	80A	- 6314 C3	70A	-	7	9	NU 316 E	80A	- 6314 C3	80A	-	15	16	N-end
IE2-K11R 280 M6 Ex e IIC	NU 317 E	85A	- 6316 C3	80A	-	7	9	NU 317 E	85A	- 6316 C3	80A	-	15	16	N-end
IE2-K11R 315 S6 Ex e IIC	NU 317 E	85A	- 6316 C3	80A	-	7	9	NU 317 E	85A	- 6316 C3	80A	-	15	16	N-end
IE2-K11R 315 M6 Ex e IIC		Relubrication device as standard					NU 2220 E	-	RB100	6316 C3	- RB85	20	19	N-end	
IE2-K11R 315 MY6, L6, LX6 Ex e IIC		Relubrication device as standard					NU 320 E	-	RB100	6317 C3	- RB85	20	19	N-end	
IE2-K12R 355 L6 Ex e IIC		Relubrication device as standard					NU 324 E	0	RB120	6317 C3	- RB85	20	19	N-end	
IE2-K11R 160 M8 Ex e IIC	NU 309 E	- RB45	6308 ZZ C3	60A	RB40	7	9	-	-	-	-	-	-	N-end	
IE2-K11R 225 S8 Ex e IIC	NU 313 E	65A	- 6312 C3	65A	-	7	9	NU 313 E	65A	- 6312 C3	65A	-	15	16	N-end
IE2-K11R 225 M8 Ex e IIC	NU 314 E	70A	- 6313 C3	70A	-	7	9	NU 314 E	70A	- 6313 C3	70A	-	15	16	N-end
IE2-K11R 250 M8 Ex e IIC	NU 316 E	80A	- 6314 C3	80A	-	7	9	NU 316 E	80A	- 6314 C3	80A	-	15	16	N-end
IE2-K11R 280 S8 Ex e IIC	NU 316 E	80A	- 6314 C3	80A	-	7	9	NU 316 E	80A	- 6314 C3	80A	-	15	16	N-end
IE2-K11R 280 M8 Ex e IIC	NU 317 E	85A	- 6316 C3	80A	-	7	9	NU 317 E	85A	- 6316 C3	80A	-	15	16	N-end
IE2-K11R 315 S8 Ex e IIC	NU 317 E	85A	- 6316 C3	80A	-	7	9	NU 317 E	85A	- 6316 C3	80A	-	15	16	N-end
IE2-K11R 315 M8 Ex e IIC	NU 317 E	85A	- 6316 C3	85A	-	7	9	NU 317 E	85A	- 6316 C3	85A	-	15	16	N-end
IE2-K11R 315 MY8 Ex e IIC		Relubrication device as standard					NU 320 E	-	RB100	6317 C3	- RB85	20	19	N-end	
IE2-K11R 315 L8 Ex e IIC		Relubrication device as standard					NU 320 E	-	RB100	6317 C3	- RB85	20	19	N-end	
IE2-K11R 315 LX8 Ex e IIC		Relubrication device as standard					NU 320 E	-	RB100	6317 C3	- RB85	20	19	N-end	

Motors in explosion-protected design

Type of explosion protection – Increased safety „e“ („eb“)

Basic version

Type	D-end (DS)					N-end (NS)		Figure		Fixed bearing
	Anti-friction bearing	V-ring	Y-ring	Wave spring	Disc spring	Anti-friction bearing	V-ring	DS	NS	
KPER 63	6201 2Z C3	-	-	-	-	6201 2Z C3	32	1	2	without
KPER 71	6202 2Z C3	-	-	-	-	6202 2Z C3	35	1	2	without
KPER 80	6204 2Z C3	-	-	-	-	6204 2Z C3	47	1	2	without
KPER 90	6205 2Z C3	-	-	-	-	6205 2Z C3	52	1	2	without
KPER 100	6205 2Z C3	-	-	-	-	6205 2Z C3	52	1	2	without
KPER 100 LX	6206 2Z C3	-	-	-	-	6206 2Z C3	62	1	2	without
KPER 112 M	6206 2Z C3	-	-	-	-	6206 2Z C3	62	1	2	without
KPER 132 S...T, SX...T	6208 2Z C3	-	-	72	-	6306 2Z C3	-	3	5	without
K11R 132 S, SX2, M6, 8	6208 2RS C3	-	-	80	-	6207 2RS C3	-	3	5	without
K11R 132 M4, MX6	6308 2RS C3	-	-	90	-	6308 2RS C3	-	3	5	without
K11R 160 M6, 8, MX8	6309 2RS C3	-	-	100	-	6308 2RS C3	-	3	5	without
K11R 160 M2, 4, MX2, L	6310 2RS C3	-	-	110	-	6309 2RS C3	-	3	5	without
K11R 180 L8	6310 2RS C3	-	-	110	-	6309 2RS C3	-	3	5	without
K11R 180 M2, 4, L4, 6	6310 C3	50A	-	110	-	6310 C3	50A	6	8	N-end
K11R 200 L2, 6, 8	6312 C3	60A	-	-	130	6310 C3	50A	6	8	N-end
K11R 200 LX2, 6, L4	6312 C3	60A	-	-	130	6312 C3	60A	6	8	N-end
K11R 225 S8	6313 C3	65A	-	-	140	6312 C3	60A	6	8	N-end
K11R 225 M2	6313 C3	65A	-	-	150	6313 C3	65A	6	8	N-end
K11R 225 S4, M4, 6, 8	6314 C3	70A	-	-	150	6313 C3	65A	6	8	N-end
K11R 250 M2	6314 C3	70A	-	-	150	6313 C3	70A	6	8	N-end
K11R 250 M4, 6, 8	NU 316 E	-	RB 80	-	-	6314 C3	70A	7	9	N-end
K11R 280 S2, M2	6316 C3	80A	-	-	170	6316 C3	80A	6	8	N-end
K11R 280 S4, 6, 8, M4, 6, 8	NU 317 E	-	RB 85	-	-	6316 C3	80A	7	9	N-end
K11R 315 S2	6316 C3	80A	-	-	170	6316 C3	80A	6	8	N-end
K11R 315 M2	NU 317 E	-	RB 85	-	-	6316 C3	80A	20	19	N-end
K11R 315 S4, 6, 8	NU 317 E	-	RB 85	-	-	6316 C3	80A	20	19	N-end
K11R 315 M4, 6, 8	NU 2220 E	-	RB100	-	-	6316 C3	80A	20	19	N-end
K11R 315 MY, L, LX 2 VL	NU 317 E	-	RB85	-	-	6317 C3 ¹⁾	85A	20	19	N-end
K11R 315 MY, L, LX 4, 6, 8 VL	NU 320 E	-	RB100	-	-	6317 C3 ¹⁾	85A	20	19	N-end

¹⁾ For types for vertical mounting Q317 C3; figures 20, 21
Size 315 M, MY, L, LX with relubrication device as standard

Reinforced bearings

Type	D-end (DS)					N-end (NS)		Figure		Fixed bearing
	Anti-friction bearing	V-ring	Y-ring	Wave spring	Disc spring	Anti-friction bearing	V-ring	DS	NS	
K11R 132 S, SX2, M6, 8	NU 208 E	-	RB40	-	-	6207 2RS C3	-	4	10	N-end
K11R 132 M4, MX6	NU 308 E	-	RB40	-	-	6308 2RS C3	-	4	10	N-end
K11R 160 M6, 8, MX8	NU 309 E	-	RB45	-	-	6308 2RS C3	-	4	10	N-end
K11R 160 M2, 4, MX2	NU 310 E	-	RB50	-	-	6309 2RS C3	-	7	9	N-end
K11R 180 L8	NU 310 E	-	RB50	-	-	6309 2RS C3	-	7	9	N-end
K11R 180 M2, 4, L4, 6	NU 310 E	-	RB50	-	-	6310 C3	50A	7	9	N-end
K11R 200 L2, 4, 6, 8	NU 312 E	-	RB60	-	-	6310 C3	50A	7	9	N-end
K11R 200 LX2, 6, L4	NU 312 E	-	RB60	-	-	6312 C3	60A	7	9	N-end
K11R 225 S8	NU 313 E	-	RB65	-	-	6312 C3	60A	7	9	N-end
K11R 225 M2	NU 313 E	-	RB65	-	-	6313 C3	60A	7	9	N-end
K11R 225 S4, M2, 4, 6, 8	NU 314 E	-	RB70	-	-	6313 C3	65A	7	9	N-end
K11R 250 M2	NU 314 E	-	RB70	-	-	6313 C3	70A	7	9	N-end
K11R 250 M4, 6, 8				Basic version corresponds to reinforced bearings						
K11R 280 S2, M2	NU 316 E	-	RB 80	-	-	6316 C3	80A	7	9	N-end
K11R 280 S4, 6, 8, M4, 6, 8				Basic version corresponds to reinforced bearings						
K11R 315 S2	NU 316 E	-	RB 80	-	-	6316 C3	80A	6	8	N-end
K11R 315 M2				Basic version corresponds to reinforced bearings						
K11R 315 S4, 6, 8				Basic version corresponds to reinforced bearings						
K11R 315 M4, 6, 8				Basic version corresponds to reinforced bearings						
K11R 315 MY, L, LX 2 VL				Basic version corresponds to reinforced bearings						
K11R 315 MY, L, LX 4, 6, 8 VL				Basic version corresponds to reinforced bearings						

¹⁾ For types for vertical mounting Q317 C3; figures 20, 21
Size 315 M, MY, L, LX with relubrication device as standard

Motors in explosion-protected design

Type of explosion protection – Increased safety „e“ („eb“)

Relubrication device

Type	D-end (DS)					N-end (NS)		Figure		Fixed bearing
	Anti-friction bearing	V-ring	Y-ring	Wave spring	Disc spring	Anti-friction bearing	V-ring	DS	NS	
K11R 132 S, SX2, M6, 8	6208 C3	-	-	80	-	6207 C3	-	3	5	N-end
K11R 132 M4, MX6	6308 C3	-	-	90	-	6308 C3	-	3	5	N-end
K11R 160 M6, 8, MX8	6309 C3	-	-	100	-	6308 C3	-	3	5	N-end
K11R 160 M2, 4, MX2, L	6310 C3	-	-	110	-	6309 C3	-	3	5	N-end
K11R 180 L8	6310 C3	-	-	110	-	6309 C3	-	3	5	N-end
K11R 180 M2, 4, L4, 6	6310 C3	50A	-	110	-	6310 C3	50A	6	8	N-end
K11R 200 L2, 6, 8	6312 C3	60A	-	-	130	6310 C3	50A	6	8	N-end
K11R 200 LX2, 6, L4	6312 C3	60A	-	-	130	6312 C3	60A	6	8	N-end
K11R 225 S8	6313 C3	65A	-	-	140	6312 C3	60A	6	8	N-end
K11R 225 M2	6313 C3	65A	-	-	150	6313 C3	65A	6	8	N-end
K11R 225 S4, M4, 6, 8	6314 C3	70A	-	-	150	6313 C3	65A	6	8	N-end
K11R 250 M2	6314 C3	70A	-	-	150	6313 C3	70A	6	8	N-end
K11R 250 M4, 6, 8	NU 316 E	-	RB 80	-	-	6314 C3	70A	7	9	N-end
K11R 280 S2, M2	6316 C3	80A	-	-	170	6316 C3	80A	6	8	N-end
K11R 280 S4, 6, 8, M4, 6, 8	NU 317 E	-	RB 85	-	-	6316 C3	80A	7	9	N-end
K11R 315 S2	6316 C3	80A	-	-	170	6316 C3	80A	6	8	N-end
K11R 315 M2	NU 317 E	-	RB 85	-	-	6316 C3	80A	20	19	N-end
K11R 315 S4, 6, 8	NU 317 E	-	RB 85	-	-	6316 C3	80A	20	19	N-end
K11R 315 M4, 6, 8	NU 2220 E	-	RB100	-	-	6316 C3	80A	20	19	N-end
K11R 315 MY, L, LX 2 VL	NU 317 E	-	RB85	-	-	6317 C3 ¹⁾	85A	20	19	N-end
K11R 315 MY, L, LX 4, 6, 8 VL	NU 320 E	-	RB100	-	-	6317 C3 ¹⁾	85A	20	19	N-end

¹⁾ For types for vertical mounting Q317 C3; figures 20, 21
Size 315 M, MY, L, LX with relubrication device as standard

Reinforced bearings with relubrication device

Type	D-end (DS)					N-end (NS)		Figure		Fixed bearing
	Anti-friction bearing	V-ring	Y-ring	Wave spring	Disc spring	Anti-friction bearing	V-ring	DS	NS	
K11R 132 S, SX2, M6, 8	NU 208 E	-	RB40	-	-	6207 C3	-	4	10	N-end
K11R 132 M4, MX6	NU 308 E	-	RB40	-	-	6308 C3	-	4	10	N-end
K11R 160 M6, 8, MX8	NU 309 E	-	RB45	-	-	6308 C3	-	4	10	N-end
K11R 160 M2, 4, MX2	NU 310 E	-	RB50	-	-	6309 C3	-	7	9	N-end
K11R 180 L8	NU 310 E	-	RB50	-	-	6309 C3	-	7	9	N-end
K11R 180 M2, 4, L4, 6	NU 310 E	-	RB50	-	-	6310 C3	50A	7	9	N-end
K11R 200 L2, 4, 6, 8	NU 312 E	-	RB60	-	-	6310 C3	50A	7	9	N-end
K11R 200 LX2, 6, L4	NU 312 E	-	RB60	-	-	6312 C3	60A	7	9	N-end
K11R 225 S8	NU 313 E	-	RB65	-	-	6312 C3	60A	7	9	N-end
K11R 225 M2	NU 313 E	-	RB65	-	-	6313 C3	60A	7	9	N-end
K11R 225 S4, M2, 4, 6, 8	NU 314 E	-	RB70	-	-	6313 C3	65A	7	9	N-end
K11R 250 M2	NU 314 E	-	RB70	-	-	6313 C3	70A	7	9	N-end
K11R 250 M4, 6, 8	-	-	-	Basic version corresponds to reinforced bearings			-	-	-	-
K11R 280 S2, M2	NU 316 E	-	RB 80	-	-	6316 C3	80A	7	9	N-end
K11R 280 S4, 6, 8, M4, 6, 8	-	-	-	Basic version corresponds to reinforced bearings			-	-	-	-
K11R 315 S2	NU 316 E	-	RB 80	-	-	6316 C3	80A	6	8	N-end
K11R 315 M2	-	-	-	Basic version corresponds to reinforced bearings			-	-	-	-
K11R 315 S4, 6, 8	-	-	-	Basic version corresponds to reinforced bearings			-	-	-	-
K11R 315 M4, 6, 8	-	-	-	Basic version corresponds to reinforced bearings			-	-	-	-
K11R 315 MY, L, LX 2 VL	-	-	-	Basic version corresponds to reinforced bearings			-	-	-	-
K11R 315 MY, L, LX 4, 6, 8 VL	-	-	-	Basic version corresponds to reinforced bearings			-	-	-	-

¹⁾ For types for vertical mounting Q317 C3; figures 20, 21
Size 315 M, MY, L, LX with relubrication device as standard

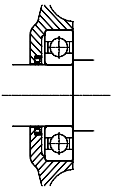
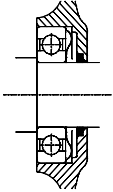
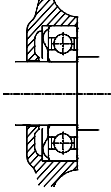
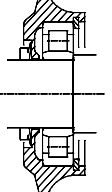
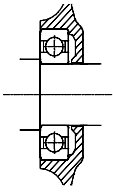
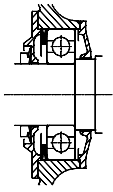
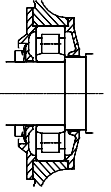
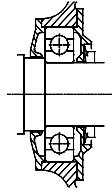
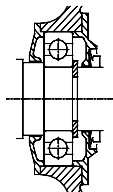
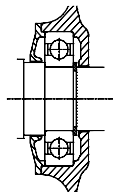
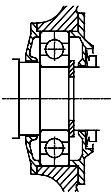
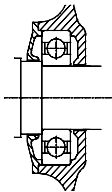
			
Figure 1	Figure 2	Figure 3	Figure 4
			
Figure 5	Figure 6	Figure 7	Figure 8
			
Figure 9	Figure 10	Figure 11	Figure 12

<p>Figure 13</p>	<p>Figure 14</p>	<p>Figure 15</p>	<p>Figure 16</p>
<p>Figure 17</p>	<p>Figure 18</p>	<p>Figure 19</p>	<p>Figure 20</p>
<p>Figure 21</p>	<p>Figure 22</p>	<p>Figure 23</p>	<p>Figure 24</p>
<p>Figure 25</p>	<p>Figure 26</p>		

Terminal boxes

Type of explosion protection – Increased safety „e“ („eb“)

Overview of terminal boxes

Type Ex e IIC	Terminal plate	$I_{B \max}$ [A]	$Q_{B \min}$ [mm ²]	$Q_{B \max}$ [mm ²]	Terminal type	Terminal thread	a [mm]
KA 05-13	KB 5580	27.5		2.5	U-clamp terminal	M4	
25 A	KB 3Ex (KS 10A)	53	6	10	Slotted terminal	S10 x 1	4.3 ± 0.1
63 A	KB 4Ex (KS 14A)	72	10	16	Slotted terminal	S14 x 1.25	6.3 ± 0.2
100 A	KB 4Ex (KS 14A)	72	10	16	Slotted terminal	S14 x 1.25	6.3 ± 0.2
200 A	KB 5Ex (KS 18A)	118	25	35	Slotted terminal	S18 x 1.5	9.2 ± 0.2
25 AV	KL 155	30		4	U-clamp terminal	M5	-
25 AV	KB 5590Ex/d 5.2	35		4	U-clamp terminal	M4	-
63 AV	KB 5121Ex-3	58.5		10	U-clamp terminal	M5	-
100 AV	KB 5121Ex-3	58.5		10	U-clamp terminal	M5	-
100 AV	KB 5130Ex	114		35	U-clamp terminal	M6	-
200 AV	KB 5130Ex	114		35	U-clamp terminal	M6	-
100/63 AV	KM 8/6, VEM 8/6	63		10	Stud/ U-clamp terminal*)	M6/M5	
200 A-SB	KM 10/8, VEM 10/8	100		70	Stud/ Tab terminal	M8/2xM6	
200 A-SB	KB 5130 Ex	118		35	U-clamp terminal	M6	-
400 A	KM 10/8, VEM 10/8	100		70	Stud/ Tab terminal	M8/2xM6	-
	KM 16/12, VEM 16/12	250		120	Stud/ Tab terminal	M12/2xM10	-
400 AV	KM 10/8, VEM 10/8	100		70	Stud/ Tab terminal	M8/2xM6	-
400 A-SB	KM 10/8, VEM 10/8	100		70	Stud/ Tab terminal	M8/2xM6	-
	KM 16/12, VEM 16/12	250		120	Stud/ Tab terminal	M12/2xM10	-
630 A	VEM KLP 630-16	455	35	300	Stud/ Screw terminal	M16 M12/M8	-
K1X 200 A	KM 10/8, VEM 10/8	100		70	Stud/ Tab terminal	M8/2xM6	-
K2X 200 A	KM 10/8, VEM 10/8	100		70	Stud/ Tab terminal	M8/2xM6	-
K1X 400 A	KM 16/12, VEM 16/12	250		120	Stud/ Tab terminal	M12/2xM10	-
K2X 400 A	KM 16/12, VEM 16/12	250		120	Stud/ Tab terminal	M12/2xM10	-
1000 A	VEM KLP 1000	1000	70	2x 240	Currentschienen	M10	-

$I_{B \max}$ max. rated current
 $Q_{B \min} / Q_{B \max}$ min./max. rated cross-section
 a Slot width of terminal stud (terminal plates to DIN 22412)

*) for single connection of solid conductors 6...10 mm², conductor bent into a loop

Only cable lugs to DIN 46295 may be used for the motor connection of motors with a terminal plate with slotted terminals. The cable lugs are attached by way of pressure nuts with integrated spring washer. Alternatively, it is permissible to realise connection by way of a solid round conductor whose diameter corresponds to the slot width of the terminal stud.

The numbers of cable glands and their assignment to different motor sizes correspond to the basic version according to DIN 42925 (see also the section “Dimensions” in Chapter 2). Customer-specific designs are possible.

Type of explosion protection – Increased safety „e“ („eb“)

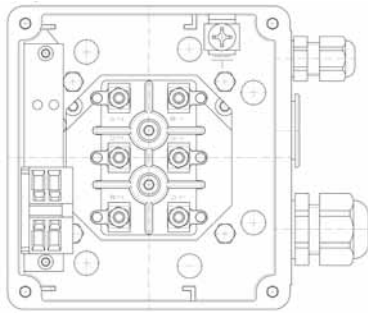
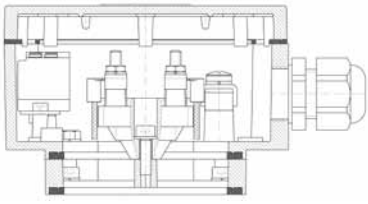

KA 05-13 Ex e IIC

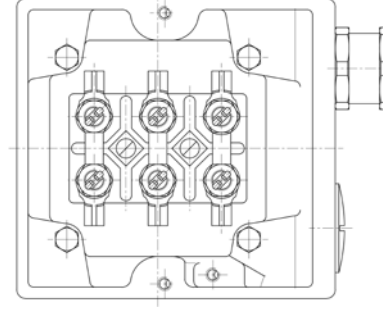
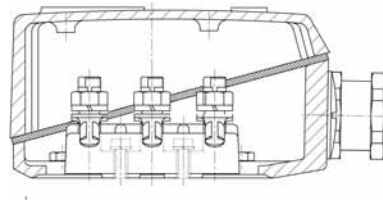

25 A, 63 A, 100 A and 200 A Ex e IIC

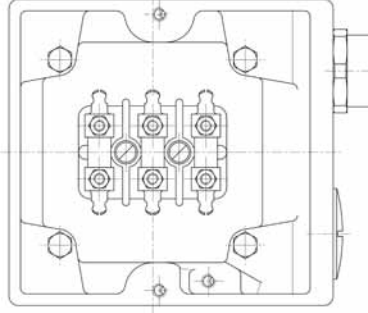
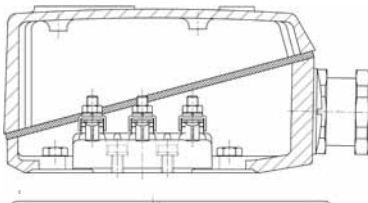

25 AV Ex e IIC

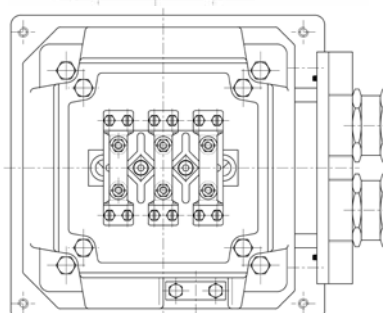
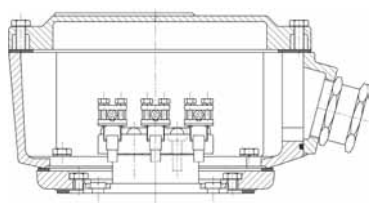

400 A, 400 AV Ex e IIC

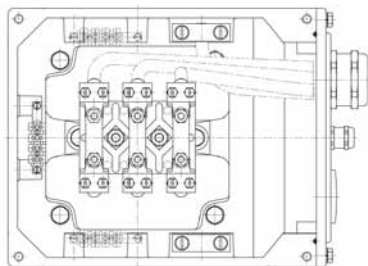
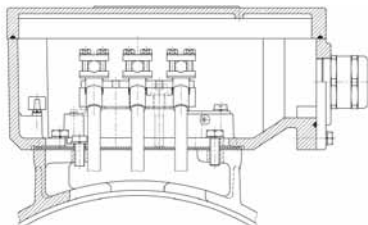

200 B, 400 B Ex e IIC

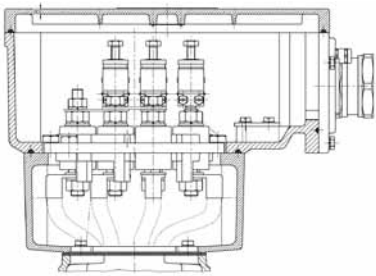

630 A Ex e IIC, gerader ZwischenFlange

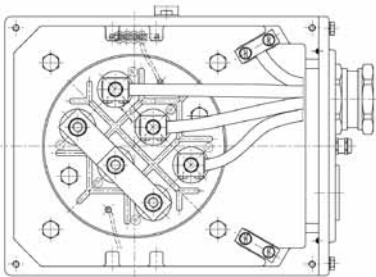

A630 Ex e IIC

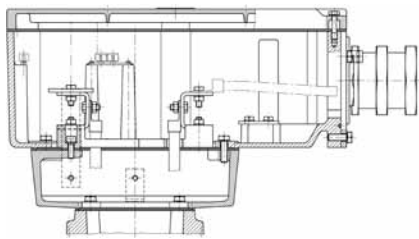

1000 A Ex e IIC, gerader ZwischenFlange

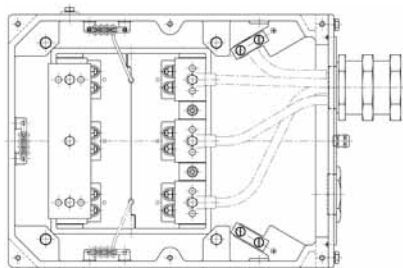

1000 A Ex e IIC

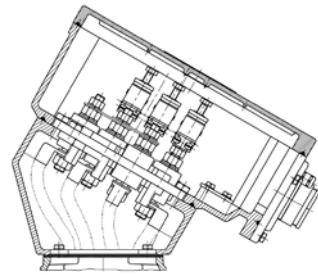

630 A Ex e IIC, inclined adapter flange

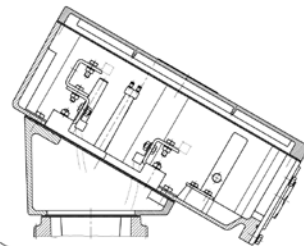
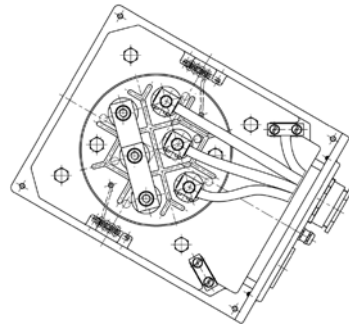

1000 A Ex e IIC, inclined adapter flange

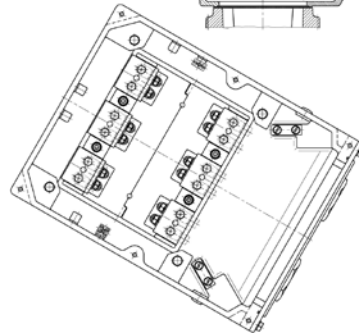

Dimensions

Three-phase motors with squirrel-cage rotor, Premium Efficiency IE3

Type of explosion protection – Increased safety „e“ („eb“) for operation in Zone 1 according to EN 60079-7 (VIK Recommendation 1, Three-Phase Asynchronous Motors – Technical Requirements 03.2011)

with surface cooling, type of cooling IC 411

Type of construction IM B3 [IM 1001]

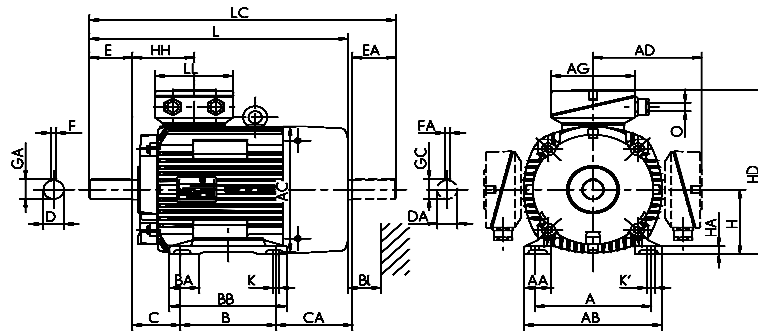

Type designation	Flange size	A	AA	AB	AC	AD	AD	B	BA	BB	C	CA	D	DA	DB ^{*)}	E	EA	F	FA
		b	n	f	g	g1	VIK g1	a	m	e	w1	w2	d	d1	l	l1	u	u1	
IE3-KPER 63 G2 Ex e IIC	FF115	100	28	128	109	116.5	116.5	80	-	100	40	39	11	11	M4	23	23	4	4
IE3-KPR 63 KY2 Ex e IIC	FF130	100	21	120	124	123	123	80	-	95	40	59	11	11	M4	23	23	4	4
IE3-KPER 63 G4 Ex e IIC	FF115	100	28	128	109	116.5	116.5	80	-	100	40	39	11	11	M4	23	23	4	4
IE3-KPR 63 G4 Ex e IIC	FF130	100	21	120	124	123	123	80	-	95	40	59	11	11	M4	23	23	4	4
IE3-KPER 71 G2 Ex e IIC	FF130	112	32	138	124	123	123	90	-	116	45	44	14	14	M5	30	30	5	5
IE3-KPR 71 K4 Ex e IIC									***)										
IE3-KPR 71 G4 Ex e IIC	FF165	112	23	135	139	130	130	90	-	114	45	63	14	14	M5	30	30	5	5
IE3-KPER 80 K2 Ex e IIC	FF165	125	38	168	139	111	111	100	-	124	50	63	19	19	M6	40	40	6	6
IE3-KPR 80 K2 Ex e IIC	FF165	125	26	152	157	138	138	100	-	124	50	80	19	19	M6	40	40	6	6
IE3-KPR 80 G2, 6 Ex e IIC	FF165	125	26	152	157	138	138	100	-	146	50	102	19	19	M6	40	40	6	6
IE3-KPR 80 K4 Ex e IIC									***)										
IE3-KPR 80 GX4 Ex e IIC	FF165	125	26	152	157	138	138	100	-	146	50	102	19	19	M6	40	40	6	6
IE3-KPR 90 S2 Ex e IIC	FF165	140	40	178	177	146	146	100	-	130	56	120	24	24	M8	50	50	8	8
IE3-KPR 90 S4 Ex e IIC	FF165	140	40	178	177	146	146	100	-	130	56	150	24	24	M8	50	50	8	8
IE3-KPR 90 L2 Ex e IIC	FF165	140	40	178	177	146	146	125	-	155	56	125	24	24	M8	50	50	8	8
IE3-KPR 90 L6 Ex e IIC	FF165	140	40	178	177	146	146	125	-	155	56	125	24	24	M8	50	50	8	8
IE3-KPR 90 LX4 Ex e IIC	FF165	140	40	178	177	146	146	125	-	155	56	150	24	24	M8	50	50	8	8
IE3-KPR 100 L2 Ex e IIC	FF215	160	42	193	196	155	155	140	-	175	63	102	28	28	M10	60	60	8	8
IE3-KPR 100 L4 Ex e IIC	FF215	160	42	193	196	155	155	140	-	175	63	166	28	28	M10	60	60	8	8
IE3-KPR 100 LZ4 Ex e IIC	FF215	160	42	193	196	155	155	140	-	175	63	206	28	28	M10	60	60	8	8
IE3-KPR 100 LX6 Ex e IIC	FF215	160	42	193	196	155	155	140	-	175	63	136	28	28	M10	60	60	8	8
IE3-KPER 112 MX2 Ex e IIC	FF215	190	52	225	196	155	155	140	-	180	70	127	28	28	M10	60	60	8	8
IE3-KPER 112 MV6 Ex e IIC	FF215	190	52	225	196	155	155	140	-	180	70	159	28	28	M10	60	60	8	8
IE3-KPR 112 M4 Ex e IIC	FF215	190	45	226	217	189	189	140	42	172	70	242	28	28	M10	60	60	8	8
IE3-KPER 132 S2T Ex e IIC	FF265	216	52	257	196	155	155	140	-	180	89	159	38	28	M12	80	60	10	8
IE3-K11R 112 M2 Ex e IIC	FF215	190	45	226	217	189	189	140	42	172	70	192	28	28	M10	60	60	8	8
IE3-K11R 132 S2 Ex e IIC	FF265	216	50	256	217	189	189	140	55	180	89	173	38	32	M12	80	80	10	10
IE3-K11R 132 SX2 Ex e IIC	FF265	216	50	256	258	210	237	140	47	180	89	176	38	32	M12	80	80	10	10
IE3-K11R 160 M2 Ex e IIC	FF300	254	55	296	313	253	279	210	60	257	108	148	42	38	M16	110	110	12	12
IE3-K11R 160 MX2 Ex e IIC	FF300	254	55	296	313	253	279	210	60	257	108	186	42	42	M17	110	110	12	12
IE3-K11R 160 L2 Ex e IIC	FF300	254	55	296	313	253	279	254	60	301	108	142	42	42	M16	110	110	12	12
IE3-K11R 180 M2C Ex e IIC	FF300	279	62	328	351	272	298	241	65	288	121	214	48	48	M16	110	110	14	14
IE3-K11R 200 L2 Ex e IIC	FF350	318	70	372	390	313	378	305	70	360	133	233	55	48	M20	110	110	16	16
IE3-K11R 200 LX2 Ex e IIC	FF350	318	70	372	390	313	378	305	70	360	133	233	55	55	M20	110	110	16	16
IE3-K11R 225 M2 Ex e IIC	FF400	356	75	413	440	324	406	311	75	368	149	267	55	55	M20	110	110	16	16
IE3-K11R 250 M2 Ex e IIC	FF500	406	84	469	490	397	397	349	84	374	168	275	60	55	M20	140	110	18	18
IE3-K11R 280 S2 Ex e IIC	FF500	457	94	522	490	397	397	368	96	482	190	234	65	65	M20	140	140	18	18
IE3-K11R 280 M2 Ex e IIC	FF500	457	88	522	550	427	427	419	94	482	190	384	65	65	M20	140	140	18	18
IE3-K11R 132 S4 Ex e IIC	FF265	216	50	256	258	210	237	140	47	180	89	186	38	32	M12	80	80	10	10
IE3-K11R 132 M4 Ex e IIC	FF265	216	50	256	258	210	237	178	47	218	89	186	38	38	M12	80	80	10	10
IE3-K11R 160 M4 Ex e IIC	FF300	254	55	296	313	253	279	210	60	257	108	148	42	38	M16	110	110	12	12
IE3-K11R 160 L4 Ex e IIC	FF300	254	55	296	313	253	279	254	60	301	108	192	42	42	M16	110	110	12	12

*) Centre holes to DIN 332-DS ...

***) upon request

Three-phase motors with squirrel-cage rotor, Premium Efficiency IE3

Type of explosion protection – Increased safety „e“ („eb“) for operation in Zone 1 according to EN 60079-7 (VIK Recommendation 1, Three-Phase Asynchronous Motors – Technical Requirements 03.2011)

with surface cooling, type of cooling IC 411

Type of construction IM B35 [IM 2001]

Flange dimensions, see page 10/6

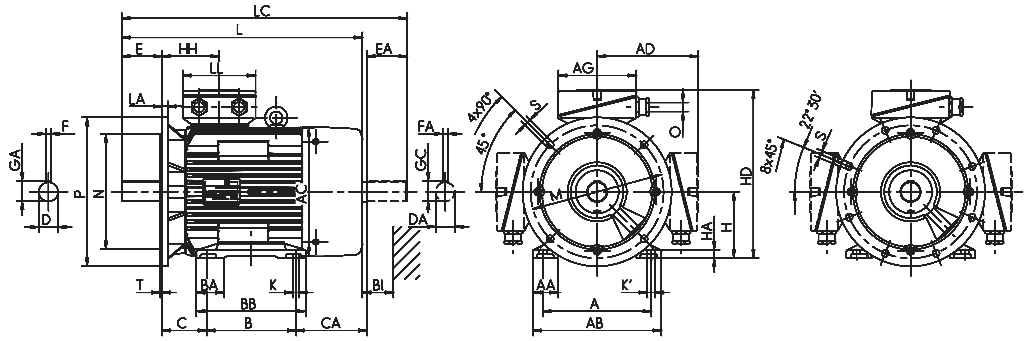

Type designation	GA	GC	H	HA	HD	HD'')	HD	HH	K	K'	L	L	L	LC	LC	TB Type	AG	LL	TB Type	AG	LL	AH	O	LB	BI
	t	t1	h	c	p	p	A	s	s'	k	k	k	k1	Ex e IIC	Ex e IIC	x	z	x	z	-	-	-	-	BI	
					VIK							(IM V1)	(IM B5)	(IM B5)	Standard			VIK							
IE3-KPER 63 G2 Ex e IIC	12.5	12.5	63	10	179.5	***	179.5	66.5	8	8	180	206	180	205	205	KA 05-13	104	112	KA 05-13	104	112	-	M20 x 1.5	4L 14	
IE3-KPR 63 KY2 Ex e IIC	12.5	12.5	63	7.5	186	***	186	70	7	7	200	225	200	225	225	KA 05-13	104	112	KA 05-13	104	112	-	M20 x 1.5	4L 14	
IE3-KPER 63 G4 Ex e IIC	12.5	12.5	63	10	179.5	***	179.5	66.5	8	8	180	206	180	205	205	KA 05-13	104	112	KA 05-13	104	112	-	M20 x 1.5	4L 14	
IE3-KPR 63 G4 Ex e IIC	12.5	12.5	63	7.5	186	***	186	70	7	7	200	225	200	225	225	KA 05-13	104	112	KA 05-13	104	112	-	M20 x 1.5	4L 14	
IE3-KPER 71 G2 Ex e IIC	16	16	71	11	193.5	***	193.5	70	8	8	207	233	207	239	239	KA 05-13	104	112	KA 05-13	104	112	-	M20 x 1.5	4L 14	
IE3-KPR 71 K4 Ex e IIC																									
IE3-KPR 71 G4 Ex e IIC	16	16	71	8	201	***	201	76	7	7	240	258	240	273	273	KA 05-13	104	112	KA 05-13	104	112	-	M20 x 1.5	4L 16	
IE3-KPER 80 K2 Ex e IIC	21.5	21.5	80	12	210	***	210	76	10	10	250	279	250	293	293	KA 05-13	104	112	KA 05-13	104	112	-	M20 x 1.5	4L 16	
IE3-KPR 80 K2 Ex e IIC	21.5	21.5	80	9	218	***	218	79	10	10	267	296	267	310	310	KA 05-13	104	112	KA 05-13	104	112	-	M20 x 1.5	4L 16	
IE3-KPR 80 G2, 6 Ex e IIC	21.5	21.5	80	9	218	***	218	79	10	10	289	318	289	332	332	KA 05-13	104	112	KA 05-13	104	112	-	M20 x 1.5	4L 16	
IE3-KPR 80 K4 Ex e IIC																									
IE3-KPR 80 GX4 Ex e IIC	21.5	21.5	80	9	218	***	218	79	10	10	289	318	289	332	332	KA 05-13	104	112	KA 05-13	104	112	-	M20 x 1.5	4L 16	
IE3-KPR 90 S2 Ex e IIC	27	27	90	10.5	236	***	236	84	10	10	323	390	323	376	415	KA 05-13	104	112	KA 05-13	104	112	-	M25 x 1.5	4L 18	
IE3-KPR 90 S4 Ex e IIC	27	27	90	10.5	236	***	236	84	10	10	353	420	353	406	445	KA 05-13	104	112	KA 05-13	104	112	-	M25 x 1.5	4L 18	
IE3-KPR 90 L2 Ex e IIC	27	27	90	10.5	236	***	236	84	10	10	353	420	353	406	445	KA 05-13	104	112	KA 05-13	104	112	-	M25 x 1.5	4L 18	
IE3-KPR 90 L6 Ex e IIC	27	27	90	10.5	236	***	236	84	10	10	353	420	353	406	445	KA 05-13	104	112	KA 05-13	104	112	-	M25 x 1.5	4L 18	
IE3-KPR 90 LX4 Ex e IIC	27	27	90	10.5	236	***	236	84	10	10	378	445	416	431	470	KA 05-13	104	112	KA 05-13	104	112	-	M25 x 1.5	4L 18	
IE3-KPR 100 L2 Ex e IIC	31	31	100	13	255	***	255	86	12	12	359	388	359	425	425	KA 05-13	104	112	KA 05-13	104	112	-	M25 x 1.5	4L 20	
IE3-KPR 100 L4 Ex e IIC	31	31	100	13	255	***	255	86	12	12	423	452	423	489	489	KA 05-13	104	112	KA 05-13	104	112	-	M25 x 1.5	4L 20	
IE3-KPR 100 LZ4 Ex e IIC	31	31	100	13	255	***	255	86	12	12	463	492	463	529	529	KA 05-13	104	112	KA 05-13	104	112	-	M25 x 1.5	4L 20	
IE3-KPR 100 LX6 Ex e IIC	31	31	100	13	255	***	255	86	12	12	393	422	393	459	459	KA 05-13	104	112	KA 05-13	104	112	-	M25 x 1.5	4L 20	
IE3-KPER 112 MX2 Ex e IIC	31	31	112	18	267	***	267	86	12	12	392	418	392	459	459	KA 05-13	104	112	KA 05-13	104	112	-	M25 x 1.5	4L 20	
IE3-KPER 112 MV6 Ex e IIC	31	31	112	18	267	***	267	86	12	12	423	452	423	489	489	KA 05-13	104	112	KA 05-13	104	112	-	M25 x 1.5	4L 20	
IE3-KPR 112 M4 Ex e IIC	31	31	112	15	301	***	301	108	12	12	509	549	509	572	572	25 A	143	134	25 AV	143	134	-	M32 x 1.5	4L 35	
IE3-KPER 132 S2T Ex e IIC	41	41	132	18	287	***	287	105	12	12	462	491	462	528	528	KA 05-13	104	112	KA 05-13	104	112	-	M32 x 1.5	4L 20	
IE3-K11R 112 M2 Ex e IIC	31	31	112	15	301	***	301	108	12	12	459	499	459	522	522	25 A	143	134	25 AV	143	134	-	M32 x 1.5	4L 35	
IE3-K11R 132 S2 Ex e IIC	41	35	132	16	321	***	321	108	12	12	479	624	479	562	562	25 A	143	134	25 AV	143	134	-	M32 x 1.5	4L 35	
IE3-K11R 132 SX2 Ex e IIC	41	35	132	15	342	***	342	114	12	12	481	621	481	565	565	25 A	143	134	25 AV	143	134	-	M32 x 1.5	4L 35	
IE3-K11R 160 M2 Ex e IIC	45	45	160	18	413	***	439	138	15	20	571	611	571	686	686	63 A	184	172	100/63 AV	223	214	-	M40 x 1.5	4L 35	
IE3-K11R 160 MX2 Ex e IIC	45	45	160	18	413	***	439	138	15	20	609	649	609	724	724	63 A	184	172	100/63 AV	223	214	-	M40 x 1.5	4L 35	
IE3-K11R 160 L2 Ex e IIC	45	45	160	18	413	***	439	138	15	20	609	649	609	724	724	63 A	184	172	100/63 AV	223	214	-	M40 x 1.5	4L 35	
IE3-K11R 180 M2C Ex e IIC	51.5	51.5	180	20	452	***	478	147	15	20	680	720	680	796	796	63 A	184	172	100/63 AV	223	214	-	M40 x 1.5	4L 35	
IE3-K11R 200 L2 Ex e IIC	59	59	200	22	513	***	578	168	19	25	767	807	767	891	891	100 A	222	214	200 A-SB	335	270	200	M50 x 1.5	4L 40	
IE3-K11R 200 LX2 Ex e IIC	59	59	200	22	513	***	578	168	19	25	767	807	767	891	891	100 A	222	214	200 A-SB	335	270	200	M50 x 1.5	4L 40	
IE3-K11R 225 M2 Ex e IIC	59	59	225	25	549	***	631	177	19	25	832	917	832	947	947	100 A	222	214	200 A-SB	335	270	200	M50 x 1.5	8L 45	
IE3-K11R 250 M2 Ex e IIC	64	59	250	28	647	***	647	206	24	30	924	1009	924	1072	1072	200 A	290	252	200 A-SB	335	270	200	M63 x 1.5	8L 55	
IE3-K11R 280 S2 Ex e IIC	69	69	280	32	677	***	677	206	24	30	970	1055	970	1118	1118	200 A	290	252	200 A-SB	335	270	200	M63 x 1.5	8L 55	
IE3-K11R 280 M2 Ex e IIC	69	69	280	40	707	***	707	211	24	30	1105	1215	1105	1273	1273	200 A	290	252	200 A-SB	335	270	200	M63 x 1.5	8L 55	
IE3-K11R 132 S4 Ex e IIC	41	35	132	15	341	***	341	114	12	12	529	569	529	613	613	25 A	143	134	25 AV	143	134	-	M32 x 1.5	4L 35	
IE3-K11R 132 M4 Ex e IIC	41	35	132	15	341	***	341	114	12	12	529	569	529	613	613	25 A	143	134	25 AV	143	134	-	M32 x 1.5	4L 35	
IE3-K11R 160 M4 Ex e IIC	45	45	160	18	413	***	439	138	15	20	571	611	571	686	686	63 A	184	172	100/63 AV	184	172	-	M40 x 1.5	4L 35	
IE3-K11R 160 L4 Ex e IIC	45	45	160	18	413	***	439	138	15	20	659	699	659	774	774	63 A	184	172	100/63 AV	184	172	-	M40 x 1.5	4L 35	

** Terminal box left/right

*** upon request

Three-phase motors with squirrel-cage rotor, Premium Efficiency IE3

Type of explosion protection – Increased safety „e“ („eb“) for operation in Zone 1 according to EN 60079-7 (VIK Recommendation 1, Three-Phase Asynchronous Motors – Technical Requirements 03.2011)

with surface cooling, type of cooling IC 411

Type of construction IM B3 [IM 1001]

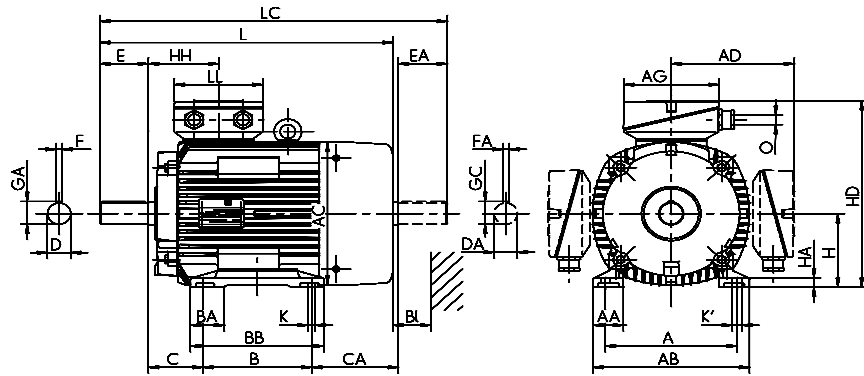

Type designation	Flange size	A	AA	AB	AC	AD	AD	B	BA	BB	C	CA	D	DA	DB ^{*)}	E	EA	F	FA
		b	n	f	g	g1	VIK g1	a	m	e	w1	w2	d	d1		l	l1	u	u1
IE3-K11R 180 M4 Ex e IIC	FF300	279	62	328	351	272	298	241	65	288	121	214	48	42	M16	110	110	14	14
IE3-K11R 180 L4 Ex e IIC	FF300	279	62	328	351	272	298	279	65	326	121	226	48	48	M16	110	110	14	14
IE3-K11R 200 L4C Ex e IIC	FF350	318	70	372	390	313	378	305	70	360	133	233	55	48	M20	110	110	16	16
IE3-K11R 225 S4 Ex e IIC	FF400	356	75	413	440	324	406	286	75	343	149	267	60	55	M20	140	110	18	16
IE3-K11R 225 M4 Ex e IIC	FF400	356	75	413	440	324	406	311	75	368	149	267	60	55	M20	140	110	18	16
IE3-K11R 250 M4 Ex e IIC	FF500	406	84	469	490	397	397	349	84	412	168	275	65	55	M20	140	110	18	16
IE3-K11R 280 S4 Ex e IIC	FF500	457	88	522	550	427	427	368	94	431	190	384	75	65	M20	140	140	20	18
IE3-K11R 280 M4 Ex e IIC	FF500	457	88	522	550	427	427	419	94	482	190	384	75	65	M20	140	140	20	18
IE3-K11R 132 S6 Ex e IIC	FF265	216	50	256	217	189	189	140	55	180	89	223	38	32	M12	80	80	10	10
IE3-K11R 132 M6 Ex e IIC	FF265	216	50	256	258	210	210	178	55	218	89	138	38	32	M12	80	80	10	10
IE3-K11R 132 MX6 Ex e IIC	FF265	216	50	256	258	210	210	178	47	218	89	236	38	38	M12	80	80	10	10
IE3-K11R 160 M6 Ex e IIC	FF300	254	55	296	313	249	242	210	56	257	108	186	42	38	M16	110	110	12	12
IE3-K11R 160 L6C Ex e IIC	FF300	254	55	296	313	249	242	254	60	301	108	192	42	42	M16	110	110	12	12
IE3-K11R 180 L6C Ex e IIC	FF300	279	62	328	351	272	298	279	65	326	121	176	48	42	M16	110	110	14	14
IE3-K11R 200 L6 Ex e IIC	FF350	318	70	372	390	313	378	305	70	360	133	233	55	48	M20	110	110	16	16
IE3-K11R 200 LX6 Ex e IIC	FF350	318	70	372	390	313	378	305	70	360	133	233	55	48	M20	110	110	16	16
IE3-K11R 225 M6 Ex e IIC	FF400	356	75	413	440	324	406	311	75	368	149	267	60	55	M20	140	110	18	16
IE3-K11R 250 M6 Ex e IIC	FF500	406	84	469	490	397	397	349	84	412	168	275	65	55	M20	140	110	18	16
IE3-K11R 280 S6 Ex e IIC	FF500	457	88	522	550	427	427	368	94	431	190	380	75	65	M20	140	140	20	18
IE3-K11R 280 M6 Ex e IIC	FF500	457	88	522	550	427	427	419	94	482	190	380	75	65	M20	140	140	20	18
IE3-K11R 132 S8 Ex e IIC	FF265	216	50	256	217	189	189	140	55	180	89	223	38	32	M12	80	80	10	10
IE3-K11R 132 M8 Ex e IIC	FF265	216	50	256	258	210	210	178	55	218	89	138	38	32	M12	80	80	10	10
IE3-K11R 160 M8 Ex e IIC	FF265	254	55	296	258	210	210	210	55	257	108	148	42	38	M16	110	110	12	12
IE3-K11R 160 MX8 Ex e IIC	FF300	254	55	296	313	249	242	210	60	257	108	148	42	42	M16	110	110	12	12
IE3-K11R 160 L8 Ex e IIC	FF300	254	55	296	313	249	242	254	60	301	108	148	42	42	M16	110	110	12	12
IE3-K11R 180 L8 Ex e IIC	FF300	279	62	328	351	272	298	279	65	326	121	226	48	42	M16	110	110	14	14
IE3-K11R 200 L8 Ex e IIC	FF350	318	70	372	351	268	301	305	70	360	133	188	55	48	M20	110	110	16	14
IE3-K11R 225 S8 Ex e IIC	FF400	356	75	413	390	302	380	286	75	343	149	286	60	55	M20	140	110	18	16
IE3-K11R 225 M8 Ex e IIC	FF400	356	75	413	440	324	406	349	84	412	149	267	60	55	M20	140	110	18	16
IE3-K11R 250 M8 Ex e IIC	FF500	406	84	469	490	397	397	349	84	412	168	275	65	55	M20	140	110	18	16
IE3-K11R 280 S8 Ex e IIC	FF500	457	94	522	490	397	397	368	94	431	190	229	75	65	M20	140	140	20	18
IE3-K11R 280 M8 Ex e IIC	FF500	457	88	522	550	427	427	419	94	482	190	380	75	65	M20	140	140	20	18

^{*)} Centre holes to DIN 332-DS ...

Three-phase motors with squirrel-cage rotor, Premium Efficiency IE3

Type of explosion protection – Increased safety „e“ („eb“) for operation in Zone 1 according to EN 60079-7 (VIK Recommendation 1, Three-Phase Asynchronous Motors – Technical Requirements 03.2011)

with surface cooling, type of cooling IC 411

Type of construction IM B35 [IM 2001]

Flange dimensions, see page 10/6

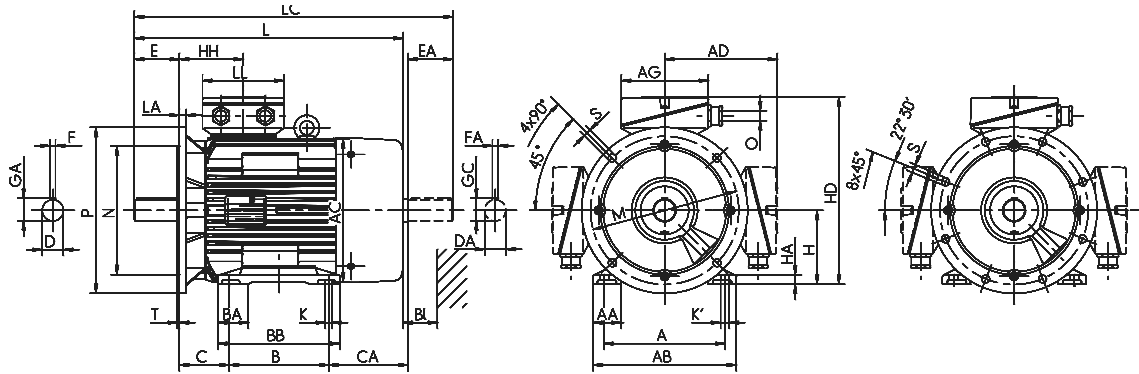

Type designation	GA	GC	H	HA	HD	HD**)	HD	HH	K	K'	L	L'	L	LC	LC	TB Type	AG	LL	TB Type	AG	LL	AH	O	LB	BI
	t	t1	h	c	p	p	p	A	s	s'	k	k	k	k1		Ex e IIC Standard	x	z	Ex e IIC VIK	x	z	-	-		BI
IE3-K11R 180 M4 Ex e IIC	51.5	51.5	180	20	452	***)	478	147	15	20	680	720	680	796	796	63 A	184	172	100/63 AV	223	214	-	M40 x 1.5	4L	35
IE3-K11R 180 L4 Ex e IIC	51.5	51.5	180	20	452	***)	478	147	15	20	730	770	730	846	846	63 A	184	172	100/63 AV	223	214	-	M40 x 1.5	4L	35
IE3-K11R 200 L4C Ex e IIC	59	59	200	22	513	***)	578	168	19	25	767	807	767	891	891	100 A	222	214	200 A-SB	335	270	200	M50 x 1.5	8L	35
IE3-K11R 225 S4 Ex e IIC	64	59	225	25	549	***)	631	177	19	25	912	997	912	1027	1027	100 A	222	214	200 A-SB	335	270	200	M50 x 1.5	8L	45
IE3-K11R 225 M4 Ex e IIC	64	59	225	25	549	***)	631	177	19	25	912	997	912	1027	1027	100 A	222	214	200 A-SB	335	270	200	M50 x 1.5	8L	45
IE3-K11R 250 M4 Ex e IIC	69	59	250	28	647	***)	647	206	24	30	924	1009	924	1072	1072	200 A	290	252	200 A-SB	335	270	200	M63 x 1.5	8L	50
IE3-K11R 280 S4 Ex e IIC	79.5	69	280	40	707	***)	707	211	24	30	1050	1160	1050	1218	1218	200 A	290	252	200 A-SB	335	270	200	M63 x 1.5	8L	55
IE3-K11R 280 M4 Ex e IIC	79.5	69	280	40	707	***)	707	211	24	30	1105	1215	1105	1273	1273	200 A	290	252	200 A-SB	335	270	200	M63 x 1.5	8L	55
IE3-K11R 132 S6 Ex e IIC	41	35	132	16	321	***)	321	108	12	12	479	519	479	562	562	25 A	143	134	25 AV	143	134	-	M32 x 1.5	4L	35
IE3-K11R 132 M6 Ex e IIC	41	35	132	16	341	***)	341	114	12	12	481	521	481	565	565	25 A	143	134	25 AV	143	134	-	M32 x 1.5	4L	35
IE3-K11R 132 MX6 Ex e IIC	41	41	132	15	331	***)	331	114	12	12	579	619	579	663	663	25 A	143	134	25 AV	143	134	-	M32 x 1.5	4L	35
IE3-K11R 160 M6 Ex e IIC	45	45	160	18	413	***)	439	138	15	20	609	649	609	724	724	63 A	184	172	100/63 AV	223	214	-	M40 x 1.5	4L	35
IE3-K11R 160 L6C Ex e IIC	45	45	160	18	413	***)	439	138	15	20	659	699	659	774	774	63 A	184	172	100/63 AV	223	214	-	M40 x 1.5	4L	35
IE3-K11R 180 L6C Ex e IIC	51.5	51.5	180	20	452	***)	478	147	15	20	680	720	680	796	796	63 A	184	172	100/63 AV	223	214	-	M40 x 1.5	4L	35
IE3-K11R 200 L6 Ex e IIC	59	59	200	22	513	***)	578	168	19	25	767	807	767	891	891	100 A	222	214	200 A-SB	335	270	200	M50 x 1.5	4L	35
IE3-K11R 200 LX6 Ex e IIC	59	59	200	22	513	***)	578	168	19	25	817	875	817	941	941	100 A	222	214	200 A-SB	335	270	200	M50 x 1.5	4L	35
IE3-K11R 225 M6 Ex e IIC	64	59	225	25	562	***)	631	177	19	25	912	997	912	1027	1027	100 A	222	214	200 A-SB	335	270	200	M50 x 1.5	8L	45
IE3-K11R 250 M6 Ex e IIC	69	59	250	28	647	***)	647	206	24	30	924	1009	924	1072	1072	200 A	290	252	200 A-SB	335	270	200	M63 x 1.5	8L	50
IE3-K11R 280 S6 Ex e IIC	79.5	69	280	40	707	***)	707	211	24	30	1050	1160	1050	1218	1218	200 A	290	252	200 A-SB	335	270	200	M63 x 1.5	8L	55
IE3-K11R 280 M6 Ex e IIC	79.5	69	280	40	707	***)	707	211	24	30	1050	1160	1050	1218	1218	200 A	290	252	200 A-SB	335	270	200	M63 x 1.5	8L	55
IE3-K11R 132 S8 Ex e IIC	41	35	132	16	321	***)	321	108	12	12	479	519	479	562	562	25 A	143	134	25 AV	143	134	-	M32 x 1.5	4L	35
IE3-K11R 132 M8 Ex e IIC	41	35	132	16	341	***)	341	114	12	12	481	521	481	564	564	25 A	143	134	25 AV	143	134	-	M32 x 1.5	4L	35
IE3-K11R 160 M8 Ex e IIC	45	45	160	18	369	***)	369	114	15	12	559	599	559	643	643	25 A	143	134	25 AV	143	134	-	M32 x 1.5	4L	35
IE3-K11R 160 MX8 Ex e IIC	45	45	160	18	413	***)	439	138	15	20	571	649	571	724	724	63 A	184	172	100/63 AV	223	214	-	M40 x 1.4	4L	35
IE3-K11R 160 L8 Ex e IIC	45	45	160	18	413	***)	439	138	15	20	571	649	571	724	724	63 A	184	172	100/63 AV	223	214	-	M40 x 1.5	4L	35
IE3-K11R 180 L8 Ex e IIC	51.5	51.5	180	20	452	***)	478	147	15	20	680	720	680	796	796	63 A	184	172	100/63 AV	223	214	-	M40 x 1.5	4L	35
IE3-K11R 200 L8 Ex e IIC	59	51.5	200	22	468	***)	478	147	19	25	680	720	680	796	796	63 A	184	172	100/63 AV	223	214	-	M50 x 1.5	4L	35
IE3-K11R 225 S8 Ex e IIC	64	59	225	25	527	***)	605	168	19	25	757	797	757	881	881	100 A	222	214	200 A-SB	335	270	200	M50 x 1.5	8L	40
IE3-K11R 225 M8 Ex e IIC	64	59	225	25	549	***)	631	177	19	25	862	997	862	977	977	100 A	222	214	200 A-SB	335	270	200	M50 x 1.5	8L	45
IE3-K11R 250 M8 Ex e IIC	69	59	250	28	647	***)	647	206	24	30	924	1009	924	1072	1072	200 A	290	252	200 A-SB	335	270	200	M63 x 1.5	8L	50
IE3-K11R 280 S8 Ex e IIC	79.5	69	280	40	677	***)	677	211	24	30	1050	1160	1050	1218	1218	200 A	290	252	200 A-SB	335	270	200	M63 x 1.5	8L	55
IE3-K11R 280 M8 Ex e IIC	79.5	69	280	40	707	***)	707	211	24	30	1050	1160	1050	1218	1218	200 A	290	252	200 A-SB	335	270	200	M63 x 1.5	8L	55

** Terminal box left/right

***) upon request

Three-phase motors with squirrel-cage rotor, Premium Efficiency IE3

Type of explosion protection – Increased safety „e“ („eb“) for operation in Zone 1 according to EN 60079-7 (VIK Recommendation 1, Three-Phase Asynchronous Motors – Technical Requirements 03.2011)

with surface cooling, type of cooling IC 411

Type of construction IM B3 [IM 1001]

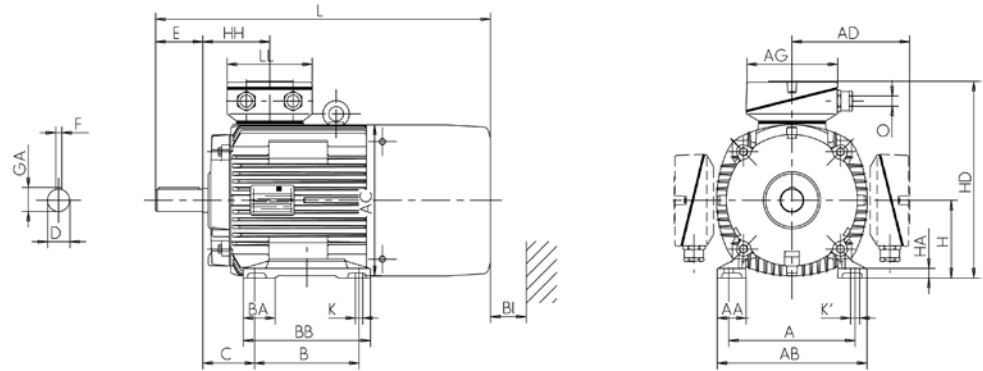

Type designation	Flange size	A	AA	AB	AC	AD	AD	B	BA	BB	C	D	DB ¹⁾	E	F
		b	n	f	g	g1	g1	a	m	e	w1	d		l	u
IE3-K11R 132 S2 G Ex e IIC	FF265	216	50	256	217	189	189	140	55	180	89	38	M12	80	10
IE3-K11R 132 SX2 G Ex e IIC	FF265	216	50	256	258	210	237	140	47	180	89	38	M12	80	10
IE3-K11R 160 M2 G Ex e IIC	FF300	254	55	296	313	253	279	210	60	257	108	42	M16	110	12
IE3-K11R 160 MX2 G Ex e IIC	FF300	254	55	296	313	253	279	210	60	257	108	42	M16	110	12
IE3-K11R 160 L2 G Ex e IIC	FF300	254	55	296	313	253	279	254	60	301	108	42	M16	110	12
IE3-K11R 180 M2C G Ex e IIC	FF300	279	62	328	351	272	298	241	65	288	121	48	M16	110	14
IE3-K11R 200 L2 G Ex e IIC	FF350	318	70	390	390	313	378	305	70	360	133	55	M20	110	16
IE3-K11R 200 LX2 G Ex e IIC	FF350	318	70	390	390	313	378	305	70	360	133	55	M20	110	16
IE3-K11R 225 M2 G Ex e IIC	FF400	356	75	440	440	324	406	311	75	368	149	55	M20	110	16
IE3-K11R 250 M2 G Ex e IIC	FF500	406	84	469	490	397	397	349	84	374	168	60	M20	140	18
IE3-K11R 280 S2 G Ex e IIC	FF500	457	94	522	490	397	397	368	96	431	190	65	M20	140	18
IE3-K11R 280 M2 G Ex e IIC	FF500	457	88	522	550	427	427	419	94	482	190	65	M20	140	18

¹⁾ Centre holes to DIN 332-DS ...

Three-phase motors with squirrel-cage rotor, Premium Efficiency IE3

Type of explosion protection – Increased safety „e“ („eb“) for operation in Zone 1 according to EN 60079-7 (VIK Recommendation 1, Three-Phase Asynchronous Motors – Technical Requirements 03.2011)

with surface cooling, type of cooling IC 411

Type of construction IM B35 [IM 2001]

Flange dimensions, see page 10/6

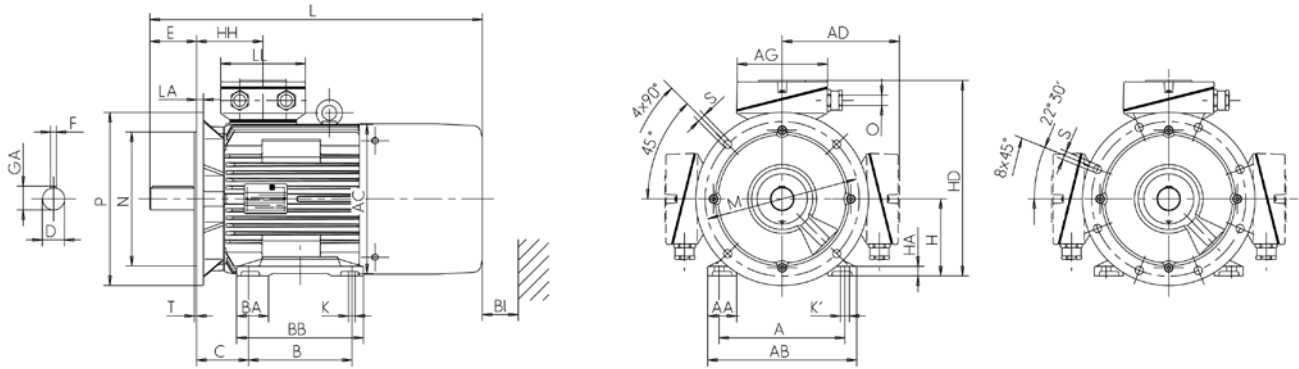

Type designation	GA	H	HA	HD	HD ^{**})	HD	HH	K	K'	L	L	L	TB Type	AG	LL	TB Type	AG	LL	AH	O	LB	BI
	t	h	c	p	p	p	A	s	s'	k	k	k	Ex e IIC Standard	x	z	Ex e IIC VIK	x	z	-	-	-	BI
IE3-K11R 132 S2 G Ex e IIC	41	132	16	321	***)	321	108	12	12	584	729	584	25 A	143	134	25 AV	143	134	-	M32 x 1.5	4L	35
IE3-K11R 132 SX2 G Ex e IIC	41	132	15	342	***)	342	114	12	12	596	636	596	25 A	143	134	25 AV	143	134	-	M32 x 1.5	4L	35
IE3-K11R 160 M2 G Ex e IIC	45	160	18	413	***)	439	138	15	20	699	739	699	63 A	184	172	100/63 AV	223	214	-	M40 x 1.5	4L	35
IE3-K11R 160 MX2 G Ex e IIC	45	160	18	413	***)	439	138	15	20	737	777	737	63 A	184	172	100/63 AV	223	214	-	M40 x 1.5	4L	35
IE3-K11R 160 L2 G Ex e IIC	45	160	18	413	***)	439	138	15	20	736	777	736	63 A	184	172	100/63 AV	223	214	-	M40 x 1.5	4L	35
IE3-K11R 180 M2C G Ex e IIC	51.5	180	20	452	***)	478	147	15	20	827	867	827	63 A	184	172	100/63 AV	223	214	-	M40 x 1.5	4L	35
IE3-K11R 200 L2 G Ex e IIC	59	200	22	513	***)	578	168	19	25	829	869	829	100 A	222	214	200 A-SB	335	270	200	M50 x 1.5	4L	40
IE3-K11R 200 LX2 G Ex e IIC	59	200	22	513	***)	578	168	19	25	829	869	829	100 A	222	214	200 A-SB	335	270	200	M50 x 1.5	4L	40
IE3-K11R 225 M2 G Ex e IIC	59	225	25	549	***)	631	177	19	25	897	982	897	100 A	222	214	200 A-SB	335	270	200	M50 x 1.5	8L	45
IE3-K11R 250 M2 G Ex e IIC	64	250	28	647	***)	647	206	24	30	1004	1089	1004	200 A	290	252	200 A-SB	335	270	200	M63 x 1.5	8L	55
IE3-K11R 280 S2 G Ex e IIC	69	280	32	677	***)	677	206	24	30	1050	1055	1050	200 A	290	252	200 A-SB	335	270	200	M63 x 1.5	8L	55
IE3-K11R 280 M2 G Ex e IIC	69	280	40	707	***)	707	211	24	30	1190	1300	1190	200 A	290	252	200 A-SB	335	270	200	M63 x 1.5	8L	55

** Terminal box left/right

***) upon request

Three-phase motors with squirrel-cage rotor, Premium Efficiency IE3

Type of explosion protection – Increased safety „e“ („eb“) for operation in Zone 1 according to EN 60079-7 (VIK Recommendation 1, Three-Phase Asynchronous Motors – Technical Requirements 03.2011)

with surface cooling, type of cooling IC 411
Size 315

Type of construction IM B3 [IM 1001]

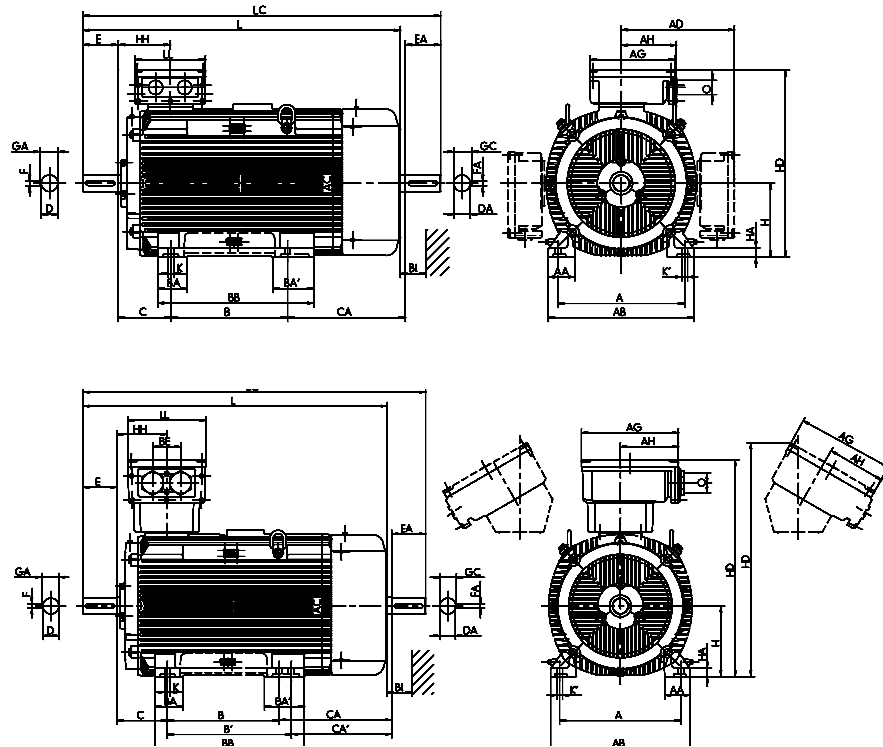

Type designation	Flange size	A	AA	AB	AC	AD	AD	B	BA	BA'	BB	C	CA	D	DA	DB ¹⁾	E	EA	F	FA
		VIK																		
		b	n	f	g	g1	g1	a	m	m1	e	w1	w2	d	d1	l	l1	u	u1	
IE3-K11R 315 S2 Ex e IIC	FF600	508	126	590	550	460	460	406	120	150	503	216	316	65	65	M20	140	140	18	18
IE3-K11R 315 M2 Ex e IIC	FF600	508	126	590	550	460	460	457	120	150	554	216	320	65	65	M20	140	140	18	18
IE3-K11R 315 MY2 Ex e IIC	FF600	508	110	590	610	681	681	457	120	-	573	216	495	65	65	M20	140	140	18	18
IE3-K11R 315 L2 Ex e IIC	FF600	508	110	590	610	681	681	508	120	-	624	216	564	65	65	M20	140	140	18	18
IE3-K11R 315 LX2 Ex e IIC	FF600	508	110	590	610	681	681	508	120	-	624	216	684	65	65	M20	140	140	18	18
IE3-K11R 315 S4 Ex e IIC	FF600	508	126	590	550	460	460	406	120	150	554	216	400	80	70	M20	170	140	22	20
IE3-K11R 315 M4 Ex e IIC	FF600	508	110	590	610	681	681	457	120	150	554	216	495	80	70	M20	170	140	22	20
IE3-K11R 315 MY4 Ex e IIC	FF600	508	110	590	610	681	681	457	120	120	573	216	495	80	70	M20	170	140	22	20
IE3-K11R 315 L4 Ex e IIC	FF600	508	110	590	610	681	681	508	120	120	624	216	684	80	70	M20	170	140	22	20
IE3-K11R 315 LX4 Ex e IIC	FF600	508	110	590	610	681	681	508	120	120	624	216	684	80	70	M20	170	140	22	20
IE3-K11R 315 S6 Ex e IIC	FF600	508	110	590	610	681	681	406	120	150	554	216	495	80	70	M20	170	140	22	20
IE3-K11R 315 M6 Ex e IIC	FF600	508	110	590	610	681	681	457	120	-	573	216	495	80	70	M20	170	140	22	20
IE3-K11R 315 MY6 Ex e IIC	FF600	508	110	590	610	681	681	457	120	-	573	216	495	80	70	M20	170	140	22	20
IE3-K11R 315 L6 Ex e IIC	FF600	508	110	590	610	681	681	508	120	-	624	216	564	80	70	M20	170	140	22	20
IE3-K11R 315 LX6 Ex e IIC	FF600	508	110	590	610	681	681	508	120	-	624	216	564	80	70	M20	170	140	22	20
IE3-K11R 315 S8 Ex e IIC	FF600	508	126	590	550	460	460	406	120	150	503	216	371	80	70	M20	170	140	22	20
IE3-K11R 315 M8 Ex e IIC	FF600	508	126	590	550	460	460	457	120	150	554	216	371	80	70	M20	170	140	22	20
IE3-K11R 315 MY8 Ex e IIC	FF600	508	110	590	610	681	681	457	120	-	573	216	495	80	70	M20	170	140	22	20
IE3-K11R 315 L8 Ex e IIC	FF600	508	110	590	610	681	681	508	120	-	624	216	564	80	70	M20	170	140	22	20
IE3-K11R 315 LX8 Ex e IIC	FF600	508	110	590	610	681	681	508	120	-	624	216	564	80	70	M20	170	140	22	20

¹⁾ Centre holes to DIN 332-DS ...

Three-phase motors with squirrel-cage rotor, Premium Efficiency IE3

Type of explosion protection – Increased safety „e“ („eb“) for operation in Zone 1 according to EN 60079-7 (VIK Recommendation 1, Three-Phase Asynchronous Motors – Technical Requirements 03.2011)

with surface cooling, type of cooling IC 411
Size 315

Type of construction IM B35 [IM 2001]

Flange dimensions, see page 10/6

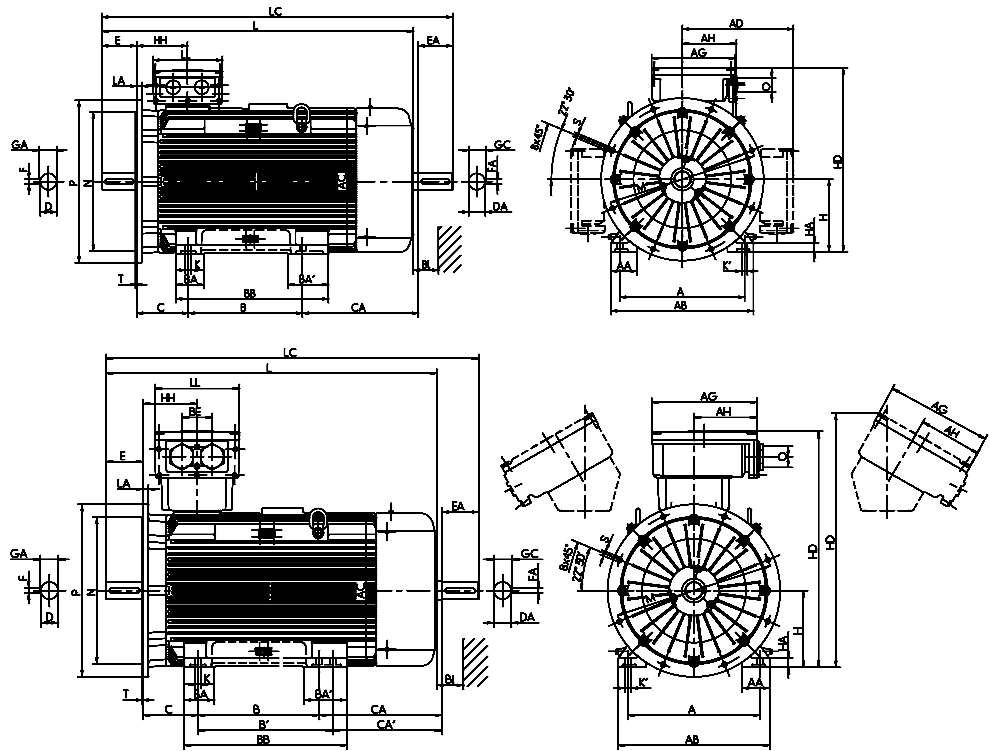

Type designation	GA	GC	H	HA	HD	HD ^{*)}	HD	HH	K	K'	L	L	L	LC	LC	TB Type	AG	LL	AH	TB	AG	LL	AH	0	LB	BI
	t	t1	h	c	p	p	p	A	s	s'	k	k	k	k1		Ex e IIC Standard	x	z	Ex e IIC VIK	x	z	-			BI	
IE3-K11R 315 S2 Ex e IIC	69	69	315	44	775	***	775	211	28	35	1105	1215	1105	1273	1273	400 A-SB	415	340	265	630 A	496	390	301	M63 x 1.5	8L	55
IE3-K11R 315 M2 Ex e IIC	69	69	315	44	775	***	775	211	28	35	1185	1295	1185	1353	1353	400 A-SB	415	340	265	630 A	496	390	301	M63 x 1.5	8L	55
IE3-K11R 315 MY2 Ex e IIC	69	69	315	44	996	***	996	230	28	35	1270	1380	1270	1448	1448	630 A	496	390	301	630 A	496	390	301	M63 x 1.5	8L	55
IE3-K11R 315 L2 Ex e IIC	69	69	315	44	996	***	996	230	28	35	1390	1500	1390	1568	1568	630 A	496	390	301	630 A	496	390	301	M63 x 1.5	8L	55
IE3-K11R 315 LX2 Ex e IIC	69	69	315	44	996	***	996	230	28	35	1510	1620	1510	1688	1688	630 A	496	390	301	630 A	496	390	301	M63 x 1.5	8L	55
IE3-K11R 315 S4 Ex e IIC	85	74.5	315	44	775	***	775	211	28	35	1210	1320	1210	1383	1383	400 A-SB	415	340	265	630 A	496	390	301	M63 x 1.5	8L	55
IE3-K11R 315 M4 Ex e IIC	85	74.5	315	44	996	***	996	230	28	35	1230	1340	1230	1408	1408	630 A	496	390	301	630 A	496	390	301	M63 x 1.5	8L	55
IE3-K11R 315 MY4 Ex e IIC	85	74.5	315	44	996	***	996	230	28	35	1300	1410	1300	1478	1478	630 A	496	390	301	630 A	496	390	301	M63 x 1.5	8L	55
IE3-K11R 315 L4 Ex e IIC	85	74.5	315	44	996	***	996	230	28	35	1540	1650	1540	1718	1718	630 A	496	390	301	630 A	496	390	301	M63 x 1.5	8L	55
IE3-K11R 315 LX4 Ex e IIC	85	74.5	315	44	996	***	996	230	28	35	1540	1650	1540	1718	1718	630 A	496	390	301	630 A	496	390	301	M63 x 1.5	8L	55
IE3-K11R 315 S6 Ex e IIC	85	74.5	315	44	775	***	809	230	28	35	1230	1340	1230	1408	1408	400 A-SB	415	340	265	630 A	496	390	301	M63 x 1.5	8L	55
IE3-K11R 315 M6 Ex e IIC	85	74.5	315	44	996	***	996	230	28	35	1300	1410	1300	1478	1478	630 A	496	390	301	630 A	496	390	301	M63 x 1.5	8L	55
IE3-K11R 315 MY6 Ex e IIC	85	74.5	315	44	996	***	996	230	28	35	1300	1410	1300	1478	1478	630 A	496	390	301	630 A	496	390	301	M63 x 1.5	8L	55
IE3-K11R 315 L6 Ex e IIC	85	74.5	315	44	996	***	996	230	28	35	1420	1530	1420	1598	1598	630 A	496	390	301	630 A	496	390	301	M63 x 1.5	8L	55
IE3-K11R 315 LX6 Ex e IIC	85	74.5	315	44	996	***	996	230	28	35	1420	1530	1420	1598	1598	630 A	496	390	301	630 A	496	390	301	M63 x 1.5	8L	55
IE3-K11R 315 S8 Ex e IIC	85	74.5	315	44	996	***	776	211	28	35	1230	1340	1230	1408	1408	630 A	496	390	301	630 A	496	390	301	M63 x 1.5	8L	55
IE3-K11R 315 M8 Ex e IIC	85	74.5	315	44	996	***	776	211	28	35	1230	1340	1230	1408	1408	630 A	496	390	301	630 A	496	390	301	M63 x 1.5	8L	55
IE3-K11R 315 MY8 Ex e IIC	85	74.5	315	44	996	***	996	230	28	35	1300	1410	1300	1478	1478	630 A	496	390	301	630 A	496	390	301	M63 x 1.5	8L	55
IE3-K11R 315 L8 Ex e IIC	85	74.5	315	44	996	***	996	230	28	35	1420	1530	1420	1598	1598	630 A	496	390	301	630 A	496	390	301	M63 x 1.5	8L	55
IE3-K11R 315 LX8 Ex e IIC	85	74.5	315	44	996	***	996	230	28	35	1420	1530	1420	1598	1598	630 A	496	390	301	630 A	496	390	301	M63 x 1.5	8L	55

*) Terminal box left/right

**) upon request

Three-phase motors with squirrel-cage rotor, Premium Efficiency IE3

Type of explosion protection – Increased safety „e“ („eb“) for operation in Zone 1 according to EN 60079-7 (VIK Recommendation 1, Three-Phase Asynchronous Motors – Technical Requirements 03.2011)

Low-noise design with direction-dependent fan

with surface cooling, type of cooling IC 411

Size 315

Type of construction IM B3 [IM 1001]

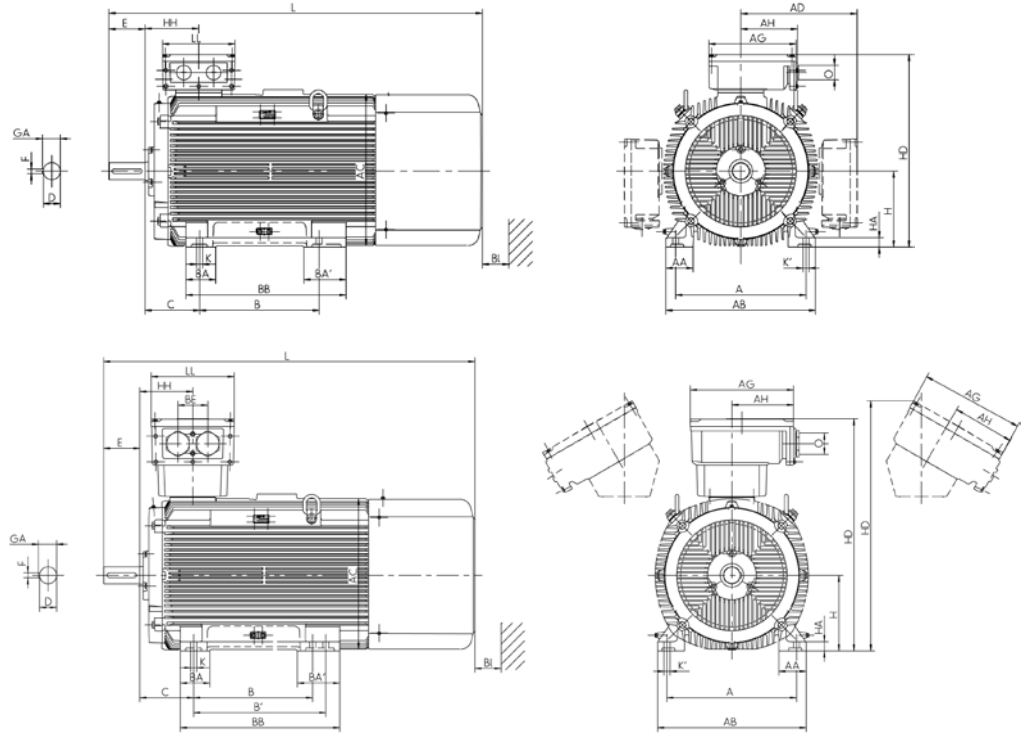

Type designation	Flange size	A	AA	AB	AC	AD	AD	B	BA	BA'	BB	C	D	DA	DB ¹⁾	E	F
		b	n	f	g	g1	VIK g1	a	m	m1	e	w1	d	d1	l		u
IE3-K11R 315 S2 G Ex e IIC	FF600	508	126	590	550	460	460	406	120	150	503	216	65	-	M20	140	18
IE3-K11R 315 M2 G Ex e IIC	FF600	508	126	590	550	460	460	457	120	150	554	216	65	65	M20	140	18
IE3-K11R 315 MY2 G Ex e IIC	FF600	508	110	590	610	681	681	457	120	-	573	216	65	65	M20	140	18
IE3-K11R 315 L2 G Ex e IIC	FF600	508	110	590	610	681	681	508	120	-	624	216	65	65	M20	140	18
IE3-K11R 315 LX2 G Ex e IIC	FF600	508	110	590	610	681	681	508	120	-	624	216	65	65	M20	140	18

¹⁾ Centre holes to DIN 332-DS ...

Three-phase motors with squirrel-cage rotor, Premium Efficiency IE3

Type of explosion protection – Increased safety „e“ („eb“) for operation in Zone 1 according to EN 60079-7 (VIK Recommendation 1, Three-Phase Asynchronous Motors – Technical Requirements 03.2011)

Low-noise design with direction-dependent fan

with surface cooling, type of cooling IC 411
Size 315

Type of construction IM B35 [IM 2001]

Flange dimensions, see page 10/6

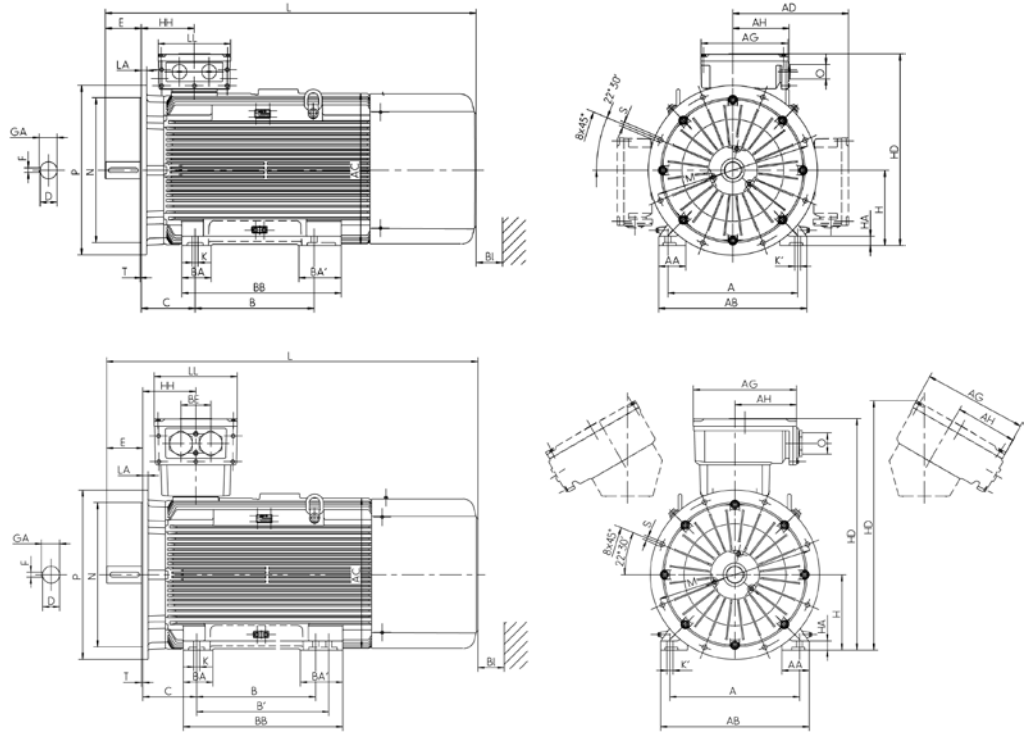

Type designation	GA	H	HA	HD	HD ^{*)}	HD	HH	K	K'	L	L	L	TB Type	AG	LL	AH	TB Type	AG	LL	AH	0	LB	BI
						VIK	A	s	s'	k	k		Ex e IIC	x	z		Ex e IIC	x	z	-			BI
	t	h	c	p	p	p				k	k		Standard				VIK						
IE3-K11R 315 S2 G Ex e IIC	69	315	44	775	***)	775	211	28	35	1190	1300	1190	400 A-SB	415	340	265	630 A	496	390	301	M63 x 1.5	8L	55
IE3-K11R 315 M2 G Ex e IIC	69	315	44	775	***)	775	211	28	35	1270	1380	1270	400 A-SB	415	340	265	630 A	496	390	301	M63 x 1.5	8L	55
IE3-K11R 315 MY2 G Ex e IIC	69	315	44	996	***)	996	230	28	35	1390	1500	1390	630 A	496	390	301	630 A	496	390	301	M63 x 1.5	8L	55
IE3-K11R 315 L2 G Ex e IIC	69	315	44	996	***)	996	230	28	35	1510	1620	1510	630 A	496	390	301	630 A	496	390	301	M63 x 1.5	8L	55
IE3-K11R 315 LX2 G Ex e IIC	69	315	44	996	***)	996	230	28	35	1630	1740	1630	630 A	496	390	301	630 A	496	390	301	M63 x 1.5	8L	55

^{*)} Terminal box left/right

^{***)} upon request

Three-phase motors with squirrel-cage rotor, Premium Efficiency IE3

Type of explosion protection – Increased safety „e“ („eb“) for operation in Zone 1 according to EN 60079-7 (VIK Recommendation 1, Three-Phase Asynchronous Motors – Technical Requirements 03.2011)

with surface cooling, type of cooling IC 411

Type of construction IM B3 [IM 1001]

Size 355 to 400, 2-pole

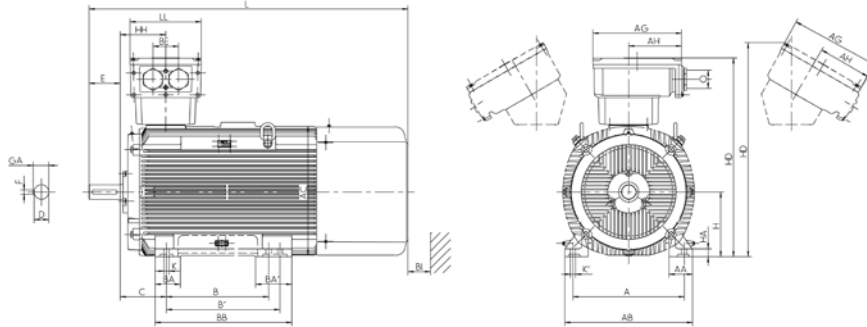

Type of construction IM B3 [IM 1001]

Size 355 to 400, 4- to 8-pole

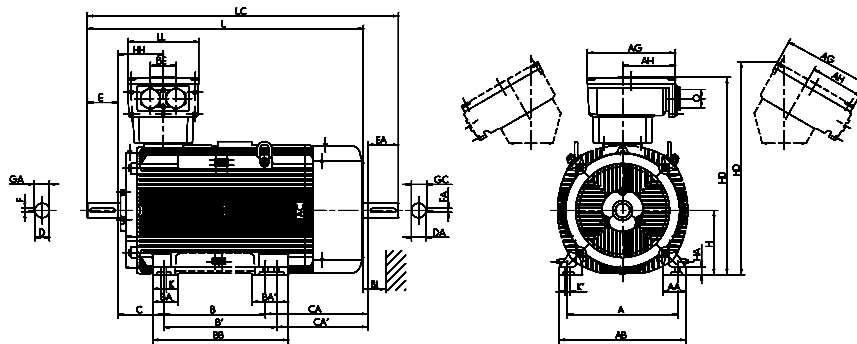

Type designation	Flange size	A	AA	AB	AC	B	BA	BA'	BB	C	CA	D	DA	DB ¹⁾	E	EA	F	FA
		b	n	f	g	a	m	m1	e	w1	w2	d	d1		l	l1	u	u1
IE3-K12R 355 M2G Ex e IIC	FF740	610	130	700	715	560	140	200	750	254	561	80	-	M20	170	-	22	-
IE3-K12R 355 MX2G Ex e IIC	FF740	610	130	700	715	560	140	200	750	254	761	80	-	M21	170	-	22	-
IE3-K12R 355 LY2G, L2G Ex e IIC	FF740	610	130	700	715	630	140	200	750	254	691	80	-	M22	170	-	22	-
IE3-W42R 355 MX2G Ex e IIC	FF 740	610	130	700	715	560	140	200	750	254	761	80	-	M20	170	-	22	-
IE3-W42R 355 L2G Ex e IIC	FF 740	610	130	700	715	630	140	200	750	254	691	80	-	M20	170	-	22	-
IE3-K11R 355 M4 Ex e IIC	FF740	610	130	700	715	560	140	200	750	254	561	100	80	M24	210	170	28	22
IE3-K11R 355 MX4 Ex e IIC	FF740	610	130	700	715	560	140	200	750	254	561	100	80	M24	210	170	28	22
IE3-K11R 355 L6 Ex e IIC	FF740	610	130	700	715	630	140	200	750	254	561	100	80	M24	210	170	28	22
IE3-K12R 355 M6 Ex e IIC	FF740	610	130	700	715	560	140	200	750	254	561	100	80	M24	210	170	28	22
IE3-K12R 355 MX6 Ex e IIC	FF740	610	130	700	715	560	140	200	750	254	681	100	80	M24	210	170	28	22
IE3-K12R 355 L6 Ex e IIC	FF740	610	130	700	715	630	140	200	750	254	611	100	80	M24	210	170	28	22
IE3-K12R 355 M8 Ex e IIC	FF740	610	130	700	715	560	140	200	750	254	561	100	80	M24	210	170	28	22
IE3-K12R 355 MX8 Ex e IIC	FF740	610	130	700	715	560	140	200	750	254	681	100	80	M24	210	170	28	22
IE3-K12R 355 L8 Ex e IIC	FF740	610	130	700	715	630	140	200	750	254	611	100	80	M24	210	170	28	22
IE3-W42R 355 MX4 Ex e IIC	FF 740	610	130	700	715	560	140	200	750	254	761	100	80	M24	210	170	28	22
IE3-W42R 355 MX6, 8 Ex e IIC	FF 740	610	130	700	715	560	140	200	750	254	761	100	80	M24	210	170	28	22
IE3-W42R 355 L4 Ex e IIC	FF 740	610	130	700	715	630	140	200	750	254	691	100	80	M24	210	170	28	22
IE3-W42R 355 L6, 8 Ex e IIC	FF 740	610	130	700	715	630	140	200	750	254	691	100	80	M24	210	170	28	22
IE3-W42R 400 M2G, MX2G Ex e IIC	FF940	686	178	820	800	630	180	240	900	280	930	80	-	M20	170	-	22	-
IE3-W42R 400 L2G Ex e IIC	FF940	686	178	820	800	710	180	240	900	280	850	80	-	M20	170	-	22	-
IE3-W42R 400 M, MX 4, 6, 8 Ex e IIC	FF940	686	178	820	800	630	180	240	900	280	930	110	80	M24	210	170	28	22
IE3-W42R 400 L4, 6, 8 Ex e IIC	FF940	686	178	820	800	710	180	240	900	280	850	110	80	M24	210	170	28	22

¹⁾ Centre holes to DIN 332-DS ...

Three-phase motors with squirrel-cage rotor, Premium Efficiency IE3

Type of explosion protection – Increased safety „e“ („eb“) for operation in Zone 1 according to EN 60079-7 (VIK Recommendation 1, Three-Phase Asynchronous Motors – Technical Requirements 03.2011)

with surface cooling, type of cooling IC 411

Type of construction IM B35 [IM 2001]

Size 355 to 400, 2-pole

Flange dimensions, see page 10/6

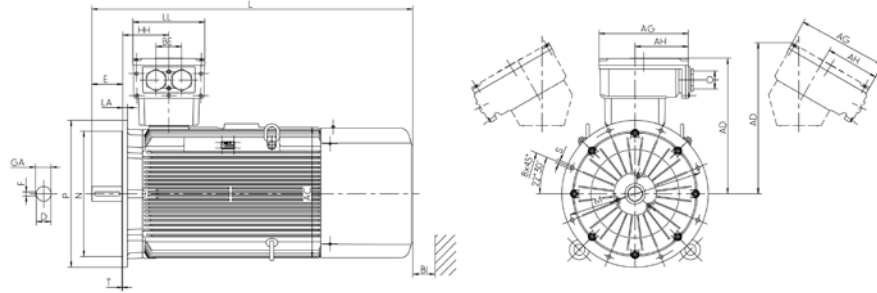

Type of construction IM B35 [IM 2001]

Size 355 to 400, 4- to 8-pole

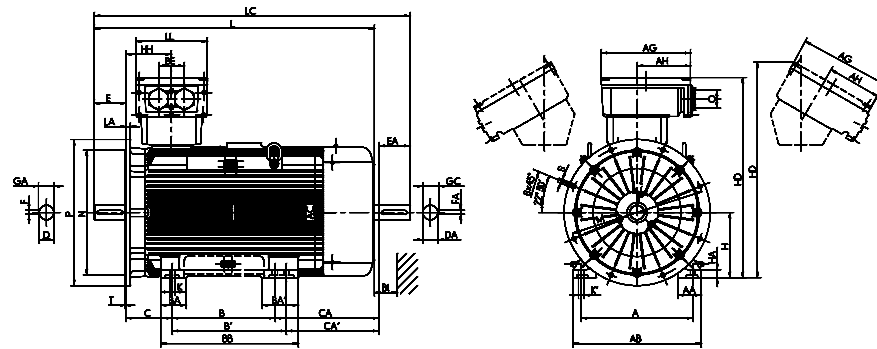

Type designation	GA	GC	H	HA	HD	HD ^{**}	HH	K	K'	L	LC	TB Type	AG	LL	AH	BE	O	BI
	t	t1	h	c	p	p	A	s	s'	k	k1	Ex e IIC Standard/ VIK	x	z	-	-	r	BI
IE3-K12R 355 M2G Ex e IIC	85	-	355	44	1088	1088	250	28	35	1530	-	630 A	496	390	301	140	M75 x 1.5	60
IE3-K12R 355 MX2G Ex e IIC	85	-	355	44	1084	1084	327	28	35	1730	-	1000 A	615	474	385	200	M75 x 1.5	60
IE3-K12R 355 LY2G, L2G Ex e IIC	85	-	355	44	1084	1084	327	28	35	1730	-	1000 A	615	474	385	200	M75 x 1.5	60
IE3-W42R 355 MX2G Ex e IIC	85	-	355	44	1084	1172	327	28	35	1730	-	1000 A	615	474	385	200	M75 x 1.5	60
IE3-W42R 355 L2G Ex e IIC	85	-	355	44	1084	1172	327	28	35	1730	-	1000 A	615	474	385	200	M75 x 1.5	60
IE3-K11R 355 M 4 Ex e IIC	106	85	355	44	1088	1088	250	28	35	1570	1755	630 A	496	390	301	140	M75 x 1.5	60
IE3-K11R 355 MX4 Ex e IIC	106	85	355	44	1088	1088	327	28	35	1770	1955	1000 A	615	474	385	200	M75 x 1.5	60
IE3-K11R 355 L6 Ex e IIC	106	85	355	44	1084	1084	327	28	35	1770	1955	1000 A	615	474	385	200	M75 x 1.5	60
IE3-K12R 355 M6 Ex e IIC	106	85	355	44	1088	1088	250	28	35	1570	1755	630 A	496	390	301	140	M75 x 1.5	60
IE3-K12R 355 MX6 Ex e IIC	106	85	355	44	1088	1088	365	28	35	1770	1955	630 A	496	390	301	140	M75 x 1.5	60
IE3-K12R 355 L6 Ex e IIC	106	85	355	44	1084	1084	327	28	35	1770	1955	1000 A	615	474	385	200	M75 x 1.5	60
IE3-K12R 355 M8 Ex e IIC	106	85	355	44	1088	1088	250	28	35	1570	1755	630 A	496	390	301	140	M75 x 1.5	60
IE3-K12R 355 MX8 Ex e IIC	106	85	355	44	1088	1088	265	28	35	1770	1955	630 A	496	390	301	140	M75 x 1.5	60
IE3-K12R 355 L8 Ex e IIC	106	85	355	44	1084	1084	327	28	35	1770	1955	1000 A	615	474	385	200	M75 x 1.5	60
IE3-W42R 355 MX4 Ex e IIC	106	85	355	44	1084	1172	327	28	35	1770	1955	1000 A	615	474	385	200	M75 x 1.5	60
IE3-W42R 355 MX6, 8 Ex e IIC	106	85	355	44	1088	1166	327	28	35	1770	1955	630 A	496	390	301	140	M75 x 1.5	60
IE3-W42R 355 L4 Ex e IIC	106	85	355	44	1084	1172	327	28	35	1770	1955	1000 A	615	474	385	200	M75 x 1.5	60
IE3-W42R 355 L6, 8 Ex e IIC	106	85	355	44	1084	1172	327	28	35	1770	1955	1000 A	615	474	385	200	M75 x 1.5	60
IE3-W42R 400 M, MX 2	85	-	400	50	1213	1273	339	35	42	1963	-	1000 A	615	474	385	200	M80 x 1.5	100
IE3-W42R 400 L2	85	-	400	50	1213	1273	339	35	42	1963	-	1000 A	615	474	385	200	M80 x 1.5	100
IE3-W42R 400 M, MX 4, 6, 8	116	85	400	50	1213	1273	339	35	42	2003	2201	1000 A	615	474	385	200	M80 x 1.5	100
IE3-W42R 400 L4, 6, 8	116	85	400	50	1213	1273	339	35	42	2003	2201	1000 A	615	474	385	200	M80 x 1.5	100

** Terminal box left/right

Three-phase motors with squirrel-cage rotor, Premium Efficiency IE3

Type of explosion protection – Increased safety „e“ („eb“) for operation in Zone 1 according to EN 60079-7 (VIK Recommendation 1, Three-Phase Asynchronous Motors – Technical Requirements 03.2011)

with surface cooling, type of cooling IC 411

Type of construction IM B14 [IM 3601]

Flange dimensions, see page 10/6

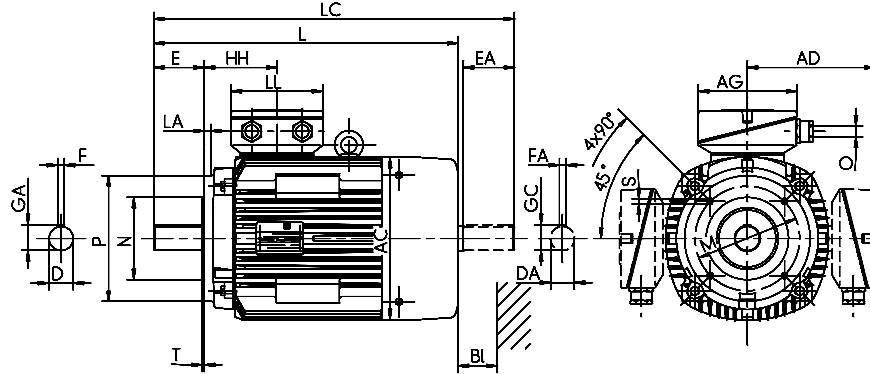

Type designation	A	AA	AB	AC	AD	AD	B	BA	BB	C	CA	D	DA	DB ¹⁾	E	EA	F	FA		
	B14K, B34K	B14G, B34G	b	n	f	g	g1	g1	a	m	e	w1	w2	d	d1	l	l1	u	u1	
IE3-KPER 63 G2 Ex e IIC	FT75	FT100	100	28	128	109	116.5	116.5	80	-	100	40	39	11	11	M4	23	23	4	4
IE3-KPR 63 KY2 Ex e IIC	FT75	FT100	100	21	120	124	123	123	80	-	95	40	59	11	11	M4	23	23	4	4
IE3-KPER 63 G4 Ex e IIC	FT75	FT100	100	28	128	109	116.5	116.5	80	-	100	40	39	11	11	M4	23	23	4	4
IE3-KPR 63 G4 Ex e IIC	FT75	FT100	100	21	120	124	123	123	80	-	95	40	59	11	11	M4	23	23	4	4
IE3-KPER 71 G2 Ex e IIC	FT85	FT115	112	32	138	124	123	123	90	-	116	45	44	14	14	M5	30	30	5	5
IE3-KPR 71 K4 Ex e IIC											***									
IE3-KPR 71 G4 Ex e IIC	FT85	FT115	112	23	135	139	130	130	90	-	114	45	63	14	14	M5	30	30	5	5
IE3-KPER 80 K2 Ex e IIC	FT100	FT130	125	38	168	139	111	111	100	-	124	50	63	19	19	M6	40	40	6	6
IE3-KPR 80 K2 Ex e IIC	FT100	FT130	125	26	152	157	138	138	100	-	124	50	80	19	19	M6	40	40	6	6
IE3-KPR 80 G2, 6 Ex e IIC	FT100	FT130	125	26	152	157	138	138	100	-	146	50	102	19	19	M6	40	40	6	6
IE3-KPR 80 K4 Ex e IIC	FT100	FT130									***									
IE3-KPR 80 GX4 Ex e IIC	FT100	FT130	125	26	152	157	138	138	100	-	146	50	102	19	19	M6	40	40	6	6
IE3-KPR 90 S2 Ex e IIC	FT115	FT130	140	40	178	177	146	146	100	-	130	56	120	24	24	M8	50	50	8	8
IE3-KPR 90 L2 Ex e IIC	FT115	FT130	140	40	178	177	146	146	100	-	130	56	150	24	24	M8	50	50	8	8
IE3-KPR 90 L6 Ex e IIC	FT115	FT130	140	40	178	177	146	146	125	-	155	56	125	24	24	M8	50	50	8	8
IE3-KPR 90 S4 Ex e IIC	FT115	FT130	140	40	178	177	146	146	125	-	155	56	125	24	24	M8	50	50	8	8
IE3-KPR 90 LX4 Ex e IIC	FT115	FT130	140	40	178	177	146	146	125	-	155	56	150	24	24	M8	50	50	8	8
IE3-KPR 100 L2 Ex e IIC	FT130	FT165	160	42	193	196	155	155	140	-	175	63	102	28	28	M10	60	60	8	8
IE3-KPR 100 L4 Ex e IIC	FT130	FT165	160	42	193	196	155	155	140	-	175	63	166	28	28	M10	60	60	8	8
IE3-KPR 100 LZ4 Ex e IIC	FT130	FT165	160	42	193	196	155	155	140	-	175	63	206	28	28	M10	60	60	8	8
IE3-KPR 100 LX6 Ex e IIC	FT130	FT165	160	42	193	196	155	155	140	-	175	63	136	28	28	M10	60	60	8	8
IE3-KPER 112 MX2 Ex e IIC	FT130	FT165	190	52	225	196	155	155	140	-	180	70	127	28	28	M10	60	60	8	8
IE3-KPR 112 M4 Ex e IIC	FT130	C200	190	45	226	217	189	189	140	42	172	70	242	28	28	M10	60	60	8	8
IE3-KPER 112 MV6 Ex e IIC	FT130	FT165	190	52	225	196	155	155	140	-	180	70	159	28	28	M10	60	60	8	8
IE3-KPER 132 S2T Ex e IIC	FT165	FT215	216	52	257	196	155	155	140	-	180	89	159	38	28	M12	80	60	10	8
IE3-K11R 112 M2 Ex e IIC	FT130	C200	190	45	226	217	189	189	140	42	172	70	192	28	28	M10	60	60	8	8
IE3-K11R 132 S2 Ex e IIC	FT130	C200	216	50	256	217	209	209	140	55	180	89	173	38	32	M12	80	80	10	10
IE3-K11R 132 SX2 Ex e IIC	FT165	C250	216	50	256	258	209	209	140	47	180	89	176	38	32	M12	80	80	10	10
IE3-K11R 160 M2 Ex e IIC	FT215	C300	254	55	296	313	253	279	210	60	257	108	148	42	42	M16	110	110	12	12
IE3-K11R 160 MX2 Ex e IIC	FT215	C300	254	55	296	313	253	279	210	60	257	108	186	42	42	M17	110	110	12	12
IE3-K11R 160 L2 Ex e IIC	FT215	C300	254	55	296	313	253	279	254	60	301	108	142	42	42	M16	110	110	12	12
IE3-K11R 132 S4 Ex e IIC	FT165	C250	216	50	256	258	209	209	140	47	180	89	186	38	32	M12	80	80	10	10
IE3-K11R 132 M4 Ex e IIC	FT165	C250	216	50	256	258	209	209	178	47	218	89	186	38	32	M12	80	80	10	10
IE3-K11R 160 M4 Ex e IIC	FT215	C300	254	55	296	313	253	279	210	60	257	108	148	42	42	M16	110	110	12	12
IE3-K11R 160 L4 Ex e IIC	FT215	C300	254	55	296	313	253	279	254	60	301	108	192	42	42	M16	110	110	12	12
IE3-K11R 132 S6 Ex e IIC	FT130	C200	216	50	256	217	189	189	140	55	180	89	223	38	32	M12	80	80	10	10
IE3-K11R 132 M6 Ex e IIC	FT165	C250	216	50	256	258	209	209	178	55	218	89	138	38	32	M12	80	80	10	10
IE3-K11R 132 MX6 Ex e IIC	FT165	C250	216	50	256	258	209	209	178	47	218	89	236	38	38	M12	80	80	10	10
IE3-K11R 160 M6 Ex e IIC	FT215	C300	254	55	296	313	253	279	210	56	257	108	186	42	42	M16	110	110	12	12
IE3-K11R 160 L6C Ex e IIC	FT215	C300	254	55	296	313	253	279	254	60	301	108	192	42	42	M16	110	110	12	12
IE3-K11R 132 S8 Ex e IIC	FT130	C200	216	50	256	217	189	189	140	55	180	89	223	38	32	M12	80	80	10	10
IE3-K11R 132 M8 Ex e IIC	FT165	C250	216	50	256	258	209	209	178	55	218	89	138	38	32	M12	80	80	10	10
IE3-K11R 160 M8 Ex e IIC	FT165	C250	254	55	296	258	209	209	210	55	257	108	148	42	42	M16	110	110	12	12
IE3-K11R 160 MX8 Ex e IIC	FT165	C250	254	55	296	313	253	279	210	60	257	108	148	42	42	M16	110	110	12	12
IE3-K11R 160 L8 Ex e IIC	FT215	C300	254	55	296	313	253	279	254	60	301	108	148	42	42	M16	110	110	12	12

¹⁾ Centre holes to DIN 332-DS ...

Three-phase motors with squirrel-cage rotor, Premium Efficiency IE3

Type of explosion protection – Increased safety „e“ („eb“) for operation in Zone 1 according to EN 60079-7 (VIK Recommendation 1, Three-Phase Asynchronous Motors – Technical Requirements 03.2011)

with surface cooling, type of cooling IC 411

Type of construction IM B34 [IM 2101]

Flange dimensions, see page 10/6

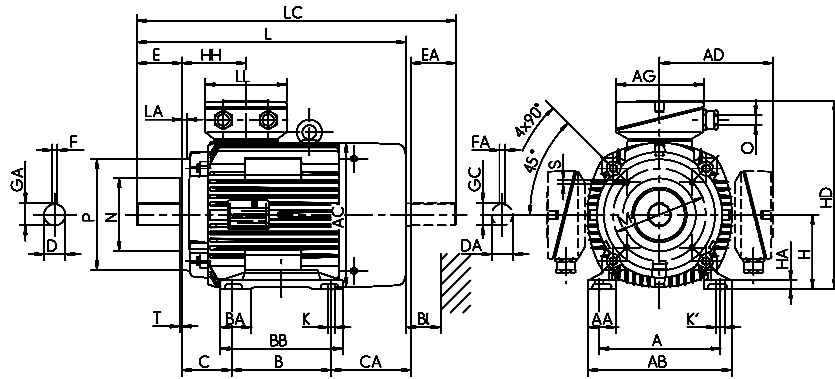

Type designation	GA	GC	H	HA	HD	HD ^{*)}	HD	HH	K	K'	L	L	L	LC	LC	TB Type	AG	LL	TB Type	AG	LL	O	LB	BI
	t	t1	h	c	p	p	p	A	s	s'	k	k	k	k1	k1	Ex e IIC	x	z	Ex e IIC	x	z			BI
							VIK				(IM V1)	(IM B5)		(IM B5)	(IM B5)	Standard			VIK					
IE3-KPER 63 G2 Ex e IIC	12.5	12.5	63	10	179.5	***	179.5	66.5	8	8	180	206	180	205	205	KA 05-13	104	112	KA 05-13	104	112	M20 x 1.5	4L	14
IE3-KPR 63 KY2 Ex e IIC	12.5	12.5	63	7.5	186	***	186	70	7	7	200	225	200	225	225	KA 05-13	104	112	KA 05-13	104	112	M20 x 1.5	4L	14
IE3-KPER 63 G4 Ex e IIC	12.5	12.5	63	10	179.5	***	179.5	66.5	8	8	180	206	180	205	205	KA 05-13	104	112	KA 05-13	104	112	M20 x 1.5	4L	14
IE3-KPR 63 G4 Ex e IIC	12.5	12.5	63	7.5	186	***	186	70	7	7	200	225	200	225	225	KA 05-13	104	112	KA 05-13	104	112	M20 x 1.5	4L	14
IE3-KPER 71 G2 Ex e IIC	16	16	71	11	193.5	***	193.5	70	8	8	207	233	207	239	239	KA 05-13	104	112	KA 05-13	104	112	M20 x 1.5	4L	14
IE3-KPR 71 K4 Ex e IIC														***										
IE3-KPR 71 G4 Ex e IIC	16	16	71	8	201	***	201	76	7	7	240	258	240	273	273	KA 05-13	104	112	KA 05-13	104	112	M20 x 1.5	4L	16
IE3-KPER 80 K2 Ex e IIC	21.5	21.5	80	12	210	***	210	76	10	10	250	279	250	293	293	KA 05-13	104	112	KA 05-13	104	112	M20 x 1.5	4L	16
IE3-KPR 80 K2 Ex e IIC	21.5	21.5	80	9	218	***	218	79	10	10	267	296	267	310	310	KA 05-13	104	112	KA 05-13	104	112	M20 x 1.5	4L	16
IE3-KPR 80 G2, 6 Ex e IIC	21.5	21.5	80	9	218	***	218	79	10	10	289	318	289	332	332	KA 05-13	104	112	KA 05-13	104	112	M20 x 1.5	4L	16
IE3-KPR 80 K4 Ex e IIC						***								***										
IE3-KPR 80 GX4 Ex e IIC	21.5	21.5	80	9	218	***	218	79	10	10	289	318	289	332	332	KA 05-13	104	112	KA 05-13	104	112	M20 x 1.5	4L	16
IE3-KPR 90 S2 Ex e IIC	27	27	90	10.5	236	***	236	84	10	10	323	390	323	376	415	KA 05-13	104	112	KA 05-13	104	112	M25 x 1.5	4L	18
IE3-KPR 90 L2 Ex e IIC	27	27	90	10.5	236	***	236	84	10	10	353	420	353	406	445	KA 05-13	104	112	KA 05-13	104	112	M25 x 1.5	4L	18
IE3-KPR 90 L6 Ex e IIC	27	27	90	10.5	236	***	236	84	10	10	353	420	353	406	445	KA 05-13	104	112	KA 05-13	104	112	M25 x 1.5	4L	18
IE3-KPR 90 S4 Ex e IIC	27	27	90	10.5	236	***	236	84	10	10	353	420	353	406	445	KA 05-13	104	112	KA 05-13	104	112	M25 x 1.5	4L	18
IE3-KPR 90 LX4 Ex e IIC	27	27	90	10.5	236	***	236	84	10	10	378	445	416	431	470	KA 05-13	104	112	KA 05-13	104	112	M25 x 1.5	4L	18
IE3-KPR 100 L2 Ex e IIC	31	31	100	13	255	***	255	86	12	12	359	388	359	425	425	KA 05-13	104	112	KA 05-13	104	112	M25 x 1.5	4L	20
IE3-KPR 100 L4 Ex e IIC	31	31	100	13	255	***	255	86	12	12	423	452	423	489	489	KA 05-13	104	112	KA 05-13	104	112	M25 x 1.5	4L	20
IE3-KPR 100 LZ4 Ex e IIC	31	31	100	13	255	***	255	86	12	12	463	492	463	529	529	KA 05-13	104	112	KA 05-13	104	112	M25 x 1.5	4L	20
IE3-KPR 100 LX6 Ex e IIC	31	31	100	13	255	***	255	86	12	12	393	422	393	459	459	KA 05-13	104	112	KA 05-13	104	112	M25 x 1.5	4L	20
IE3-KPER 112 MX2 Ex e IIC	31	31	112	18	267	***	267	86	12	12	392	418	392	459	459	KA 05-13	104	112	KA 05-13	104	112	M25 x 1.5	4L	20
IE3-KPR 112 M4 Ex e IIC	31	31	112	15	301	***	301	108	12	12	509	549	509	572	572	25 A	143	134	25 AV	143	134	M32 x 1.5	4L	35
IE3-KPER 112 MV6 Ex e IIC	31	31	112	18	267	***	267	86	12	12	423	452	423	489	489	KA 05-13	104	112	KA 05-13	104	112	M25 x 1.5	4L	20
IE3-KPER 132 S2T Ex e IIC	41	41	132	18	287	***	287	105	12	12	462	491	462	528	528	KA 05-13	104	112	KA 05-13	104	112	M32 x 1.5	4L	20
IE3-K11R 112 M2 Ex e IIC	31	31	112	15	301	***	301	108	12	12	459	499	459	522	522	25 A	143	134	25 AV	143	134	M32 x 1.5	4L	35
IE3-K11R 132 S2 Ex e IIC	41	41	132	16	321	***	321	108	12	12	479	519	479	562	562	25 A	143	134	25 AV	143	134	M32 x 1.5	4L	35
IE3-K11R 132 SX2 Ex e IIC	41	41	132	15	341	***	441	114	12	12	481	521	481	565	565	25 A	143	134	25 AV	143	134	M32 x 1.5	4L	35
IE3-K11R 160 M2 Ex e IIC	45	45	160	18	413	***	439	138	15	20	571	611	571	686	686	63 A	184	172	100/63 AV	184	172	M40 x 1.5	4L	35
IE3-K11R 160 MX2 Ex e IIC	45	45	160	18	413	***	439	138	15	20	609	649	609	724	724	63 A	184	172	100/63 AV	184	172	M40 x 1.5	4L	35
IE3-K11R 160 L2 Ex e IIC	45	45	160	18	413	***	439	138	15	20	609	649	609	724	724	63 A	184	172	100/63 AV	184	172	M40 x 1.5	4L	35
IE3-K11R 132 S4 Ex e IIC	41	41	132	15	341	***	341	114	12	12	529	569	529	613	613	25 A	143	134	25 AV	143	134	M32 x 1.5	4L	35
IE3-K11R 132 M4 Ex e IIC	41	41	132	15	341	***	341	114	12	12	529	569	529	613	613	25 A	143	134	25 AV	143	134	M32 x 1.5	4L	35
IE3-K11R 160 M4 Ex e IIC	45	45	160	18	413	***	439	138	15	20	571	611	571	686	686	63 A	184	172	100/63 AV	184	172	M40 x 1.5	4L	35
IE3-K11R 160 L4 Ex e IIC	45	45	160	18	413	***	439	138	15	20	659	699	659	774	774	63 A	184	172	100/63 AV	184	172	M40 x 1.5	4L	35
IE3-K11R 132 S6 Ex e IIC	41	41	132	16	321	***	321	108	12	12	479	519	479	562	562	25 A	143	134	25 AV	143	134	M32 x 1.5	4L	35
IE3-K11R 132 M6 Ex e IIC	41	41	132	16	341	***	341	114	12	12	481	521	481	565	565	25 A	143	134	25 AV	143	134	M32 x 1.5	4L	35
IE3-K11R 132 MX6 Ex e IIC	41	41	132	15	341	***	341	114	12	12	579	619	579	663	663	25 A	143	134	25 AV	143	134	M32 x 1.5	4L	35
IE3-K11R 160 M6 Ex e IIC	45	45	160	18	413	***	439	138	15	20	609	649	609	724	724	63 A	184	172	100/63 AV	184	172	M40 x 1.5	4L	35
IE3-K11R 160 L6C Ex e IIC	45	45	160	18	413	***	439	138	15	20	659	699	659	774	774	63 A	184	172	100/63 AV	184	172	M40 x 1.5	4L	35
IE3-K11R 132 S8 Ex e IIC	41	41	132	16	321	***	321	108	12	12	479	519	479	562	562	25 A	143	134	25 AV	143	134	M32 x 1.5	4L	35
IE3-K11R 132 M8 Ex e IIC	41	41	132	16	341	***	341	114	12	12	481	521	481	564	564	25 A	143	134	25 AV	143	134	M32 x 1.5	4L	35
IE3-K11R 160 M8 Ex e IIC	45	45	160	18	413	***	439	138	15	20	571	649	571	724	724	63 A	184	172	25 AV	143	134	M40 x 1.5	4L	35
IE3-K11R 160 L8 Ex e IIC	45	45	160	18	413	***	439	138	15	20	571	649	571	724	724	63 A	184	172	100/63 AV	184	172	M40 x 1.5	4L	35

**) Terminal box left/right

**) upon request

Three-phase motors with squirrel-cage rotor, Premium Efficiency IE3

Type of explosion protection – Increased safety „e“ („eb“) for operation in Zone 1 according to EN 60079-7 (VIK Recommendation 1, Three-Phase Asynchronous Motors – Technical Requirements 03.2011)

Low-noise design with direction-dependent fan

with surface cooling, type of cooling IC 411

Type of construction IM B14 [IM 3601]

Flange dimensions, see page 10/6

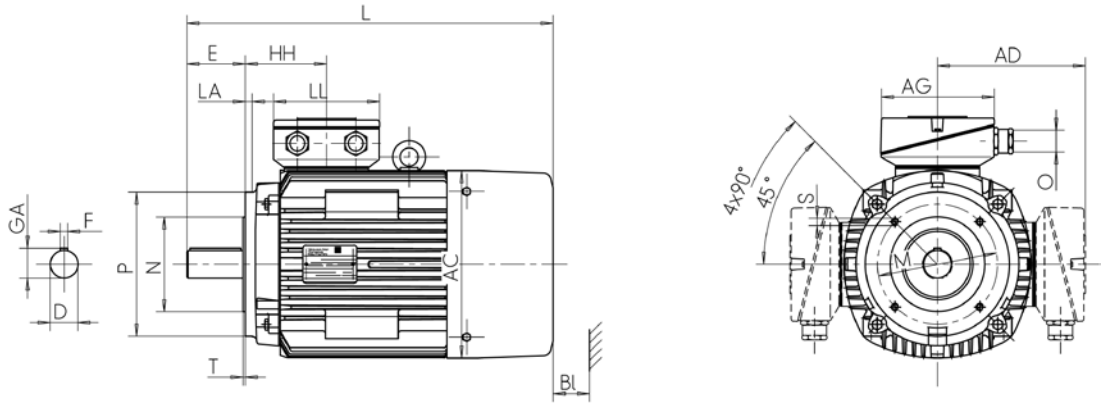

Type designation	Flange size	A	AA	AB	AC	AD	AD	B	BA	BA'	BB	C	D	DB ¹⁾	E	F
		b	n	f	g	g1	VIK g1	a	m	m1	e	w1	d		l	u
IE3-K11R 132 S2 G Ex e IIC	FT130	C200	216	50	256	217	209	209	140	55	180	89	38	M12	80	10
IE3-K11R 132 SX2 G Ex e IIC	FT165	C250	216	50	256	258	209	209	140	47	180	89	38	M12	80	10
IE3-K11R 160 M2 G Ex e IIC	FT215	C300	254	55	296	313	253	279	210	60	257	108	42	M16	110	12
IE3-K11R 160 MX2 G Ex e IIC	FT215	C300	254	55	296	313	253	279	210	60	257	108	42	M16	110	12
IE3-K11R 160 L2 G Ex e IIC	FT215	C300	254	55	296	313	253	279	254	60	301	108	42	M16	110	12

¹⁾ Centre holes to DIN 332-DS ...

Three-phase motors with squirrel-cage rotor, Premium Efficiency IE3

Type of explosion protection – Increased safety „e“ („eb“) for operation in Zone 1 according to EN 60079-7 (VIK Recommendation 1, Three-Phase Asynchronous Motors – Technical Requirements 03.2011)

Low-noise design with direction-dependent fan

with surface cooling, type of cooling IC 411

Type of construction IM B34 [IM 2101]

Flange dimensions, see page 10/6

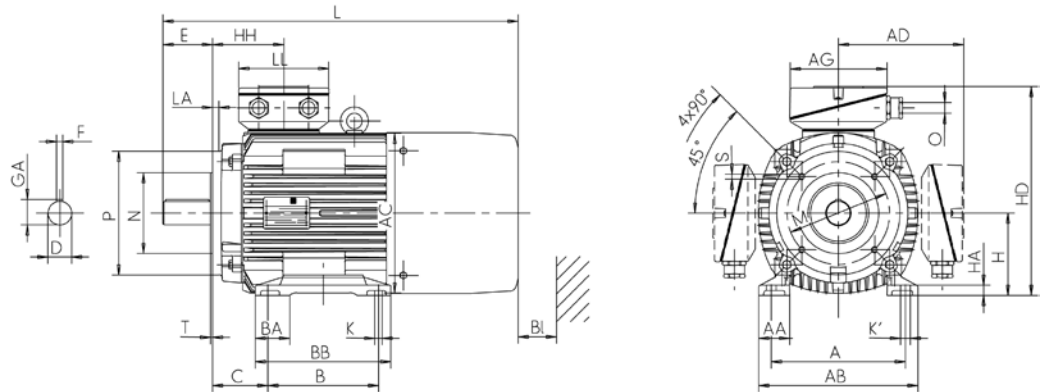

Type designation	GA	H	HA	HD	HD ^{**}	HD	HH	K	K'	L	L	L	TB Type	AG	LL	TB Type	AG	LL	O	LB	BI
	t	h	c	p	p	p	A	s	s'	k	k	k	Ex e IIC Standard	x	z	Ex e IIC VIK	x	z	-		BI
IE3-K11R 132 S2 G Ex e IIC	41	132	16	321	***)	321	108	12	12	584	724	689	25 A	143	134	25 AV	143	134	M32 x 1.5	4L	35
IE3-K11R 132 SX2 G Ex e IIC	41	132	15	341	***)	341	114	12	12	596	636	481	25 A	143	134	25 AV	143	134	M32 x 1.5	4L	35
IE3-K11R 160 M2 G Ex e IIC	45	160	18	413	***)	439	138	15	20	699	739	698	63 A	184	172	100/63 AV	222	214	M40 x 1.5	4L	35
IE3-K11R 160 MX2 G Ex e IIC	45	160	18	413	***)	439	138	15	20	737	777	736	63 A	184	172	100/63 AV	222	214	M40 x 1.5	4L	35
IE3-K11R 160 L2 G Ex e IIC	45	160	18	413	***)	439	138	15	20	737	777	736	63 A	184	172	100/63 AV	222	214	M40 x 1.5	4L	35

** Terminal box left/right

***) upon request

Three-phase motors with squirrel-cage rotor, Premium Efficiency IE3

Type of explosion protection – Increased safety „e“ („eb“) for operation in Zone 1 according to EN 60079-7 (VIK Recommendation 1, Three-Phase Asynchronous Motors – Technical Requirements 03.2011)

with surface cooling, type of cooling IC 411

Type of construction IM B5 [IM 3001], IM V1 [IM 3011]

Flange dimensions, see page 10/6

Type designation	Flange B5	AC	AD	AD VIK	D	DA	DB ^{*)}	E	EA	F	FA	GA	GC	H	HH	L
		g	g1	g1	d	d1		l	l1	u	u1	t	t1	h	A	k
IE3-KPER 63 G2 Ex e IIC	FF115	109	116.5	116.5	11	11	M4	23	23	4	4	12.5	12.5	63	66.5	180
IE3-KPR 63 KY2 Ex e IIC	FF130	124	123	123	11	11	M4	23	23	4	4	12.5	12.5	63	70	200
IE3-KPER 63 G4 Ex e IIC	FF115	109	116.5	116.5	11	11	M4	23	23	4	4	12.5	12.5	63	66.5	180
IE3-KPR 63 G4 Ex e IIC	FF130	124	123	123	11	11	M4	23	23	4	4	12.5	12.5	63	70	200
IE3-KPER 71 G2 Ex e IIC	FF130	124	123	123	14	14	M5	30	30	5	5	16	16	71	70	207
IE3-KPR 71 K4 Ex e IIC								***)								
IE3-KPR 71 G4 Ex e IIC	FF165	139	130	130	14	14	M5	30	30	5	5	16	16	71	76	240
IE3-KPER 80 K2 Ex e IIC	FF165	139	111	111	19	19	M6	40	40	6	6	21.5	21.5	80	76	250
IE3-KPR 80 K2 Ex e IIC	FF165	157	138	138	19	19	M6	40	40	6	6	21.5	21.5	80	79	267
IE3-KPR 80 G2, 6 Ex e IIC	FF165	157	138	138	19	19	M6	40	40	6	6	21.5	21.5	80	79	289
IE3-KPR 80 K4 Ex e IIC								***)								
IE3-KPR 80 GX4 Ex e IIC	FF165	157	138	138	19	19	M6	40	40	6	6	21.5	21.5	80	79	289
IE3-KPR 90 S2 Ex e IIC	FF165	177	146	146	24	24	M8	50	50	8	8	27	27	90	84	323
IE3-KPR 90 L2 Ex e IIC	FF165	177	146	146	24	24	M8	50	50	8	8	27	27	90	123	353
IE3-KPR 90 L6 Ex e IIC	FF165	177	146	146	24	24	M8	50	50	8	8	27	27	90	123	353
IE3-KPR 90 S4 Ex e IIC	FF165	177	146	146	24	24	M8	50	50	8	8	27	27	90	123	353
IE3-KPR 90 LX4 Ex e IIC	FF165	177	146	146	24	24	M8	50	50	8	8	27	27	90	123	378
IE3-KPR 100 L2 Ex e IIC	FF215	196	155	155	28	28	M10	60	60	8	8	31	31	100	86	359
IE3-KPR 100 L4 Ex e IIC	FF215	196	155	155	28	28	M10	60	60	8	8	31	31	100	86	423
IE3-KPR 100 LZ4 Ex e IIC	FF215	196	155	155	28	28	M10	60	60	8	8	31	31	100	86	463
IE3-KPR 100 LX6 Ex e IIC	FF215	196	155	155	28	28	M10	60	60	8	8	31	31	100	86	393
IE3-KPER 112 MX2 Ex e IIC	FF215	196	168	168	28	28	M10	60	60	8	8	31	31	112	86	392
IE3-KPR 112 M4 Ex e IIC	FF215	217	189	189	28	28	M10	60	60	8	8	31	31	112	108	509
IE3-KPER 112 MV6 Ex e IIC	FF215	196	155	155	28	28	M10	60	60	8	8	31	31	112	86	423
IE3-KPER 132 S2T Ex e IIC	FF265	196	155	155	38	28	M12	80	60	10	8	41	31	132	105	462
IE3-K11R 112 M2 Ex e IIC	FF215	217	189	189	28	28	M10	60	60	8	8	31	31	112	108	459
IE3-K11R 132 S2 Ex e IIC	FF265	217	189	189	38	32	M12	80	80	10	10	41	35	132	108	479
IE3-K11R 132 SX2 Ex e IIC	FF265	258	210	237	38	32	M12	80	80	10	10	41	35	132	114	481
IE3-K11R 160 M2 Ex e IIC	FF300	313	253	279	42	42	M16	110	110	12	12	45	45	160	138	571
IE3-K11R 160 MX2 Ex e IIC	FF300	313	253	279	42	42	M17	110	110	12	12	45	45	160	138	609
IE3-K11R 160 L2 Ex e IIC	FF300	313	253	279	42	42	M16	110	110	12	12	45	45	160	138	609
IE3-K11R 180 M2C Ex e IIC	FF300	351	272	298	48	48	M16	110	110	14	14	51.5	51.5	180	147	680
IE3-K11R 200 L2 Ex e IIC	FF350	390	313	378	55	55	M20	110	110	16	16	59	59	200	168	767
IE3-K11R 200 LX2 Ex e IIC	FF350	390	313	378	55	55	M20	110	110	16	16	59	59	200	168	767
IE3-K11R 225 M2 Ex e IIC	FF300	440	324	406	55	55	M20	110	110	16	16	59	59	225	177	832
IE3-K11R 250 M2 Ex e IIC	FF500	490	397	397	60	55	M20	140	110	18	18	64	59	250	206	924
IE3-K11R 280 S2 Ex e IIC	FF500	490	397	397	65	65	M20	140	140	18	18	69	69	280	206	970
IE3-K11R 280 M2 Ex e IIC	FF500	550	427	427	65	65	M20	140	140	18	18	69	69	280	211	1105
IE3-K11R 132 S4 Ex e IIC	FF265	258	210	237	38	32	M12	80	80	10	10	41	35	132	114	529
IE3-K11R 132 M4 Ex e IIC	FF265	258	210	237	38	32	M12	80	80	10	10	41	35	132	114	529
IE3-K11R 160 M4 Ex e IIC	FF300	313	253	279	42	42	M16	110	110	12	12	45	45	160	138	571
IE3-K11R 160 L4 Ex e IIC	FF300	313	253	279	42	42	M16	110	110	12	12	45	45	160	138	659
IE3-K11R 180 M4 Ex e IIC	FF300	351	272	298	48	48	M16	110	110	14	14	51.5	51.5	180	147	680
IE3-K11R 180 L4 Ex e IIC	FF300	351	272	298	48	48	M16	110	110	14	14	51.5	51.5	180	147	730
IE3-K11R 200 L4C Ex e IIC	FF350	390	313	378	55	55	M20	110	110	16	16	59	59	200	168	767
IE3-K11R 225 M4 Ex e IIC	FF300	440	324	406	60	55	M20	140	110	18	16	64	59	225	177	912
IE3-K11R 225 M4 Ex e IIC	FF300	440	324	406	60	55	M20	140	110	18	16	64	59	225	177	912
IE3-K11R 250 M4 Ex e IIC	FF500	490	397	397	65	55	M20	140	110	18	16	69	59	250	206	924
IE3-K11R 280 S4 Ex e IIC	FF500	550	427	427	75	65	M20	140	140	20	18	79.5	69	280	211	1050
IE3-K11R 280 M4 Ex e IIC	FF500	550	427	427	75	65	M20	140	140	20	18	79.5	69	280	211	1105
IE3-K11R 132 S6 Ex e IIC	FF265	217	189	189	38	32	M12	80	80	10	10	41	35	132	108	479
IE3-K11R 132 M6 Ex e IIC	FF265	258	210	210	38	32	M12	80	80	10	10	41	35	132	114	481
IE3-K11R 132 MX6 Ex e IIC	FF265	258	210	210	38	38	M12	80	80	10	10	41	41	132	114	579
IE3-K11R 160 M6 Ex e IIC	FF300	313	249	242	42	42	M16	110	110	12	12	45	45	160	138	609
IE3-K11R 160 L6C Ex e IIC	FF300	313	249	242	42	42	M16	110	110	12	12	45	45	160	138	659
IE3-K11R 180 L6C Ex e IIC	FF300	351	272	298	48	48	M16	110	110	14	14	51.5	51.5	180	147	680

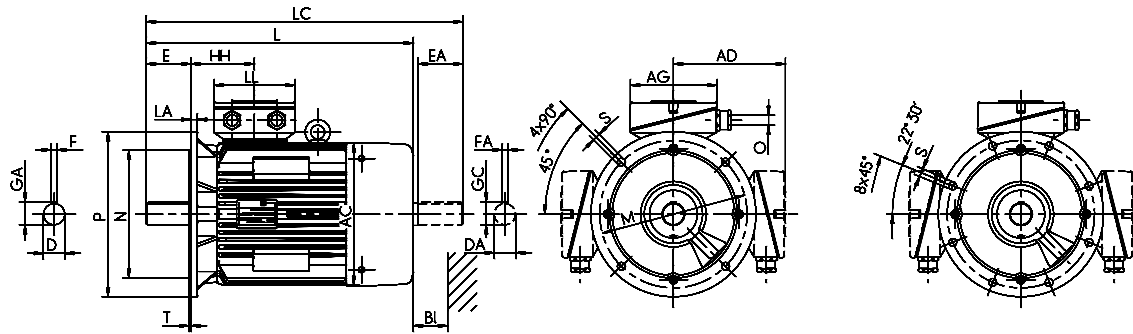

Type designation	L k (IM V1)	L k (IM B5)	LC k1	LC k1 (IM B5)	TB Type Ex e IIC Standard	AG x	LL z	TB Type Ex e IIC VIK	AG x	LL z	AH -	O -	LB	BI
IE3-KPER 63 G2 Ex e IIC	206	180	205	205	KA 05-13	104	112	KA 05-13	104	112	-	M20 x 1.5	4L	14
IE3-KPR 63 KY2 Ex e IIC	225	200	225	225	KA 05-13	104	112	KA 05-13	104	112	-	M20 x 1.5	4L	14
IE3-KPER 63 G4 Ex e IIC	206	180	205	205	KA 05-13	104	112	KA 05-13	104	112	-	M20 x 1.5	4L	14
IE3-KPR 63 G4 Ex e IIC	225	200	225	225	KA 05-13	104	112	KA 05-13	104	112	-	M20 x 1.5	4L	14
IE3-KPER 71 G2 Ex e IIC	233	207	239	239	KA 05-13	104	112	KA 05-13	104	112	-	M20 x 1.5	4L	14
IE3-KPR 71 K4 Ex e IIC					***)									
IE3-KPR 71 G4 Ex e IIC	258	240	273	273	KA 05-13	104	112	KA 05-13	104	112	-	M20 x 1.5	4L	16
IE3-KPER 80 K2 Ex e IIC	279	250	293	293	KA 05-13	104	112	KA 05-13	104	112	-	M20 x 1.5	4L	16
IE3-KPR 80 K2 Ex e IIC	296	267	310	310	KA 05-13	104	112	KA 05-13	104	112	-	M20 x 1.5	4L	16
IE3-KPR 80 G2, 6 Ex e IIC	318	289	332	332	KA 05-13	104	112	KA 05-13	104	112	-	M20 x 1.5	4L	16
IE3-KPR 80 K4 Ex e IIC					***)									
IE3-KPR 80 GX4 Ex e IIC	318	289	332	332	KA 05-13	104	112	KA 05-13	104	112	-	M20 x 1.5	4L	16
IE3-KPR 90 S2 Ex e IIC	390	323	376	415	KA 05-13	104	112	KA 05-13	104	112	-	M25 x 1.5	4L	18
IE3-KPR 90 L2 Ex e IIC	420	353	406	445	KA 05-13	104	112	KA 05-13	104	112	-	M25 x 1.5	4L	18
IE3-KPR 90 L6 Ex e IIC	420	353	406	445	KA 05-13	104	112	KA 05-13	104	112	-	M25 x 1.5	4L	18
IE3-KPR 90 S4 Ex e IIC	420	353	406	445	KA 05-13	104	112	KA 05-13	104	112	-	M25 x 1.5	4L	18
IE3-KPR 90 LX4 Ex e IIC	445	416	431	470	KA 05-13	104	112	KA 05-13	104	112	-	M25 x 1.5	4L	18
IE3-KPR 100 L2 Ex e IIC	388	359	425	425	KA 05-13	104	112	KA 05-13	104	112	-	M25 x 1.5	4L	20
IE3-KPR 100 L4 Ex e IIC	452	423	489	489	KA 05-13	104	112	KA 05-13	104	112	-	M25 x 1.5	4L	20
IE3-KPR 100 LZ4 Ex e IIC	492	463	529	529	KA 05-13	104	112	KA 05-13	104	112	-	M25 x 1.5	4L	20
IE3-KPR 100 LX6 Ex e IIC	422	393	459	459	KA 05-13	104	112	KA 05-13	104	112	-	M25 x 1.5	4L	20
IE3-KPER 112 MX2 Ex e IIC	418	392	459	459	KA 05-13	104	112	KA 05-13	104	112	-	M25 x 1.5	4L	20
IE3-KPR 112 M4 Ex e IIC	549	509	572	572	25 A	104	112	KA 05-13	104	112	-	M25 x 1.5	4L	20
IE3-KPER 112 MV6 Ex e IIC	452	423	489	489	KA 05-13	104	112	KA 05-13	104	112	-	M25 x 1.5	4L	20
IE3-KPER 132 S2T Ex e IIC	491	462	528	528	KA 05-13	104	112	KA 05-13	104	112	-	M32 x 1.5	4L	20
IE3-K11R 112 M2 Ex e IIC	499	459	522	522	25 A	143	134	25 AV	143	134	-	M32 x 1.5	4L	35
IE3-K11R 132 S2 Ex e IIC	619	479	562	562	25 A	143	134	25 AV	143	134	-	M32 x 1.5	4L	35
IE3-K11R 132 SX2 Ex e IIC	521	481	565	565	25 A	143	134	25 AV	143	134	-	M32 x 1.5	4L	35
IE3-K11R 160 M2 Ex e IIC	611	571	686	686	63 A	184	172	100/63 AV	222	214	-	M40 x 1.5	4L	35
IE3-K11R 160 MX2 Ex e IIC	649	609	724	724	63 A	184	172	100/63 AV	222	214	-	M40 x 1.5	4L	35
IE3-K11R 160 L2 Ex e IIC	649	609	724	724	63 A	184	172	100/63 AV	222	214	-	M40 x 1.5	4L	35
IE3-K11R 180 M2C Ex e IIC	720	680	796	796	63 A	184	172	100/63 AV	222	214	-	M40 x 1.5	4L	35
IE3-K11R 200 L2 Ex e IIC	807	767	891	891	100 A	222	214	200 A-SB	335	270	200	M50 x 1.5	4L	40
IE3-K11R 200 LX2 Ex e IIC	807	767	891	891	100 A	222	214	200 A-SB	335	270	200	M50 x 1.5	4L	40
IE3-K11R 225 M2 Ex e IIC	917	832	947	947	63 A	222	214	200 A-SB	335	270	200	M50 x 1.5	8L	45
IE3-K11R 250 M2 Ex e IIC	1009	924	1072	1072	200 A	290	252	200 A-SB	335	270	200	M63 x 1.5	8L	55
IE3-K11R 280 S2 Ex e IIC	1055	970	1118	1118	200 A	290	252	200 A-SB	335	270	200	M63 x 1.5	8L	55
IE3-K11R 280 M2 Ex e IIC	1215	1105	1273	1273	200 A	290	252	200 A-SB	335	270	200	M63 x 1.5	8L	55
IE3-K11R 132 S4 Ex e IIC	569	529	613	613	25 A	143	134	25 AV	143	134	-	M32 x 1.5	4L	35
IE3-K11R 132 M4 Ex e IIC	569	529	613	613	25 A	143	134	25 AV	143	134	-	M32 x 1.5	4L	35
IE3-K11R 160 M4 Ex e IIC	611	571	686	686	63 A	184	172	100/63 AV	222	214	-	M40 x 1.5	4L	35
IE3-K11R 160 L4 Ex e IIC	699	659	774	774	63 A	184	172	100/63 AV	222	214	-	M40 x 1.5	4L	35
IE3-K11R 180 M4 Ex e IIC	720	680	796	796	63 A	184	172	100/63 AV	222	214	-	M40 x 1.5	4L	35
IE3-K11R 180 L4 Ex e IIC	770	730	846	846	63 A	184	172	100/63 AV	222	214	-	M40 x 1.5	4L	35
IE3-K11R 200 L4C Ex e IIC	807	767	891	891	100 A	222	214	200 A-SB	335	270	200	M50 x 1.5	4L	35
IE3-K11R 225 M4 Ex e IIC	997	912	1027	1027	100 A	222	214	200 A-SB	335	270	200	M50 x 1.5	8L	45
IE3-K11R 225 M4 Ex e IIC	997	912	1027	1027	100 A	222	214	200 A-SB	335	270	200	M50 x 1.5	8L	45
IE3-K11R 250 M4 Ex e IIC	1009	924	1072	1072	200 A	290	252	200 A-SB	335	270	200	M63 x 1.5	8L	50
IE3-K11R 280 S4 Ex e IIC	1160	1050	1218	1218	200 A	290	252	200 A-SB	335	270	200	M63 x 1.5	8L	55
IE3-K11R 280 M4 Ex e IIC	1215	1105	1273	1273	200 A	290	252	200 A-SB	335	270	200	M63 x 1.5	8L	55
IE3-K11R 132 S6 Ex e IIC	519	479	562	562	25 A	143	134	25 AV	143	134	-	M32 x 1.5	4L	35
IE3-K11R 132 M6 Ex e IIC	521	481	565	565	25 A	143	134	25 AV	143	134	-	M32 x 1.5	4L	35
IE3-K11R 132 MX6 Ex e IIC	619	579	663	663	25 A	143	134	25 AV	143	134	-	M32 x 1.5	4L	35
IE3-K11R 160 M6 Ex e IIC	649	609	724	724	63 A	184	172	100/63 AV	223	214	-	M40 x 1.5	4L	35
IE3-K11R 160 L6C Ex e IIC	699	659	774	774	63 A	184	172	100/63 AV	223	214	-	M40 x 1.5	4L	35
IE3-K11R 180 L6C Ex e IIC	720	680	796	796	63 A	184	172	100/63 AV	223	214	-	M40 x 1.5	4L	35

***) upon request

Three-phase motors with squirrel-cage rotor, Premium Efficiency IE3

Type of explosion protection – Increased safety „e“ („eb“) for operation in Zone 1 according to EN 60079-7 (VIK Recommendation 1, Three-Phase Asynchronous Motors – Technical Requirements 03.2011)

with surface cooling, type of cooling IC 411

Type of construction IM B5 [IM 3001], IM V1 [IM 3011]

Flange dimensions, see page 10/6

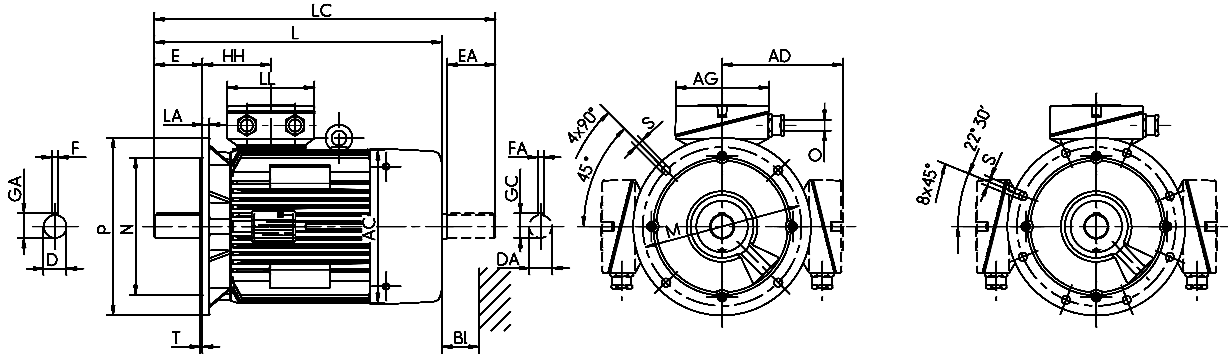

Type designation	Flange B5	AC	AD	AD VIK	D	DA	DB ¹⁾	E	EA	F	FA	GA	GC	H	HH	L
	g	g1	g1	g1	d	d1		l	l1	u	u1	t	t1	h	A	k
IE3-K11R 200 L6 Ex e IIC	FF350	390	313	378	55	55	M20	110	110	16	16	59	59	200	168	767
IE3-K11R 200 LX6 Ex e IIC	FF350	390	313	378	55	55	M20	110	110	16	16	59	59	200	168	817
IE3-K11R 225 M6 Ex e IIC	FF300	440	324	406	60	55	M20	140	110	18	16	64	59	225	177	912
IE3-K11R 250 M6 Ex e IIC	FF500	490	397	397	65	55	M20	140	110	18	16	69	59	250	206	924
IE3-K11R 280 S6 Ex e IIC	FF500	550	427	427	75	65	M20	140	140	20	18	79.5	69	280	211	1050
IE3-K11R 280 M6 Ex e IIC	FF500	550	427	427	75	65	M20	140	140	20	18	79.5	69	280	211	1050
IE3-K11R 132 S8 Ex e IIC	FF265	217	189	189	38	32	M12	80	80	10	10	41	35	132	108	479
IE3-K11R 132 M8 Ex e IIC	FF265	258	210	210	38	32	M12	80	80	10	10	41	35	132	114	481
IE3-K11R 160 M8 Ex e IIC	FF265	258	210	210	42	42	M16	110	110	12	12	45	45	160	114	559
IE3-K11R 160 MX8 Ex e IIC	FF300	313	249	242	42	42	M16	110	110	12	12	45	45	160	138	571
IE3-K11R 160 L8 Ex e IIC	FF300	313	249	242	42	42	M16	110	110	12	12	45	45	160	138	571
IE3-K11R 180 L8 Ex e IIC	FF300	351	272	298	48	48	M16	110	110	14	14	51.5	51.5	180	147	680
IE3-K11R 200 L8 Ex e IIC	FF350	351	268	301	55	48	M20	110	110	16	14	59	51.5	200	147	680
IE3-K11R 225 S8 Ex e IIC	FF300	390	302	380	60	55	M20	140	110	18	16	64	59	225	168	757
IE3-K11R 225 M8 Ex e IIC	FF300	440	324	406	60	55	M20	140	110	18	16	64	59	225	177	862
IE3-K11R 250 M8 Ex e IIC	FF500	490	397	397	65	55	M20	140	110	18	16	69	59	250	206	924
IE3-K11R 280 S8 Ex e IIC	FF500	490	397	397	75	65	M20	140	140	20	18	79.5	69	280	211	1050
IE3-K11R 280 M8 Ex e IIC	FF500	550	427	427	75	65	M20	140	140	20	18	79.5	69	280	211	1050

¹⁾ Centre holes to DIN 332-DS ...

Type designation	L k (IM V1)	L k (IM B5)	LC k1	LC k1 (IM B5)	TB Type Ex e IIC Standard	AG x	LL z	TB Type Ex e IIC VIK	AG x	LL z	AH -	O -	LB	BI BI
IE3-K11R 200 L6 Ex e IIC	807	767	891	891	100 A	222	214	200 A-SB	335	270	200	M40 x 1.5	4L	35
IE3-K11R 200 LX6 Ex e IIC	875	817	941	941	100 A	222	214	200 A-SB	335	270	200	M50 x 1.5	4L	35
IE3-K11R 225 M6 Ex e IIC	997	912	1027	1027	100 A	222	214	200 A-SB	335	270	200	M50 x 1.5	8L	45
IE3-K11R 250 M6 Ex e IIC	1009	924	1072	1072	200 A	222	214	200 A-SB	335	270	200	M63 x 1.5	8L	50
IE3-K11R 280 S6 Ex e IIC	1160	1050	1218	1218	200 A	290	252	200 A-SB	335	270	200	M63 x 1.5	8L	55
IE3-K11R 280 M6 Ex e IIC	1160	1050	1218	1218	200 A	290	252	200 A-SB	335	270	200	M63 x 1.5	8L	55
IE3-K11R 132 S8 Ex e IIC	519	479	562	562	25 A	143	134	25 AV	143	134	-	M32 x 1.5	4L	35
IE3-K11R 132 M8 Ex e IIC	521	481	564	564	25 A	143	134	25 AV	143	134	-	M32 x 1.5	4L	35
IE3-K11R 160 M8 Ex e IIC	599	559	643	643	63 A	184	172	25 AV	143	134	-	M32 x 1.5	4L	35
IE3-K11R 160 MX8 Ex e IIC	649	571	724	724	63 A	184	172	25 AV	143	134	-	M32 x 1.5	4L	35
IE3-K11R 160 L8 Ex e IIC	649	571	724	724	63 A	184	172	100/63 AV	223	214	-	M40 x 1.5	4L	35
IE3-K11R 180 L8 Ex e IIC	720	680	796	796	63 A	184	172	100/63 AV	223	214	-	M40 x 1.5	4L	35
IE3-K11R 200 L8 Ex e IIC	720	680	796	796	63 A	184	172	100/63 AV	223	214	-	M50 x 1.5	4L	35
IE3-K11R 225 S8 Ex e IIC	797	757	881	881	100 A	222	214	200 A-SB	335	270	200	M50 x 1.5	8L	40
IE3-K11R 225 M8 Ex e IIC	997	862	977	977	100 A	222	214	200 A-SB	335	270	200	M50 x 1.5	8L	45
IE3-K11R 250 M8 Ex e IIC	1009	924	1072	1072	200 A	290	252	200 A-SB	335	270	200	M63 x 1.5	8L	50
IE3-K11R 280 S8 Ex e IIC	1160	1050	1218	1218	200 A	290	252	200 A-SB	335	270	200	M63 x 1.5	8L	55
IE3-K11R 280 M8 Ex e IIC	1160	1050	1218	1218	200 A	290	252	200 A-SB	335	270	200	M63 x 1.5	8L	55

Three-phase motors with squirrel-cage rotor, Premium Efficiency IE3

Type of explosion protection – Increased safety „e“ („eb“) for operation in Zone 1 according to EN 60079-7 (VIK Recommendation 1, Three-Phase Asynchronous Motors – Technical Requirements 03.2011)

Low-noise design with direction-dependent fan

with surface cooling, type of cooling IC 411

Type of construction IM B5 [IM 3001], IM V1 [IM 3011]

Flange dimensions, see page 10/6

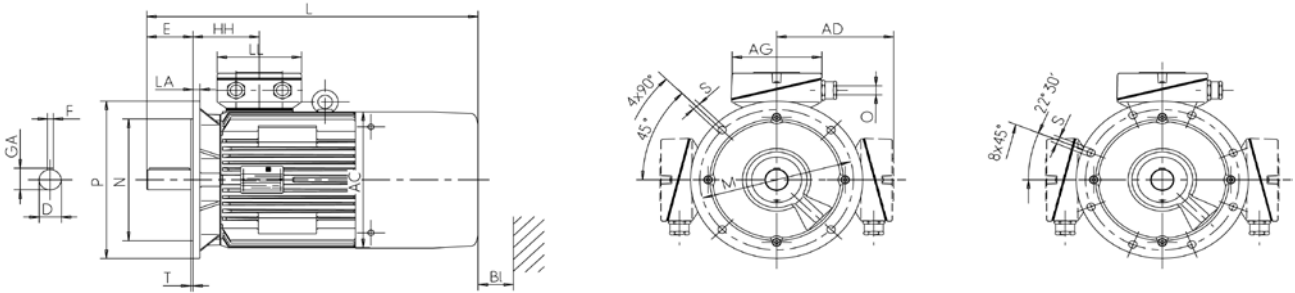

Type designation	Flange B5	AC	AD	AD VIK	D	DB ¹⁾	E	F	GA	H	HH	L
		g	g1	g1	d		l	u	t	h	A	k
IE3-K11R 132 S2 G Ex e IIC	FF265	217	189	189	38	M12	80	10	41	132	108	584
IE3-K11R 132 SX2 G Ex e IIC	FF265	258	210	237	38	M12	80	10	41	132	114	596
IE3-K11R 160 M2 G Ex e IIC	FF300	313	253	279	42	M16	110	12	45	160	138	699
IE3-K11R 160 MX2 G Ex e IIC	FF300	313	253	279	42	M16	110	12	45	160	138	737
IE3-K11R 160 L2 G Ex e IIC	FF300	313	253	279	42	M16	110	12	45	160	138	737
IE3-K11R 180 M2C G Ex e IIC	FF300	351	272	298	48	M16	110	14	51.5	180	147	827
IE3-K11R 200 L2 G Ex e IIC	FF350	390	313	378	55	M20	110	16	59	200	168	829
IE3-K11R 200 LX2 G Ex e IIC	FF350	390	313	378	55	M20	110	16	59	200	168	829
IE3-K11R 225 M2 G Ex e IIC	FF300	440	324	406	55	M20	110	16	59	225	177	897
IE3-K11R 250 M2 G Ex e IIC	FF500	490	397	397	60	M20	140	18	64	250	206	1004
IE3-K11R 280 S2 G Ex e IIC	FF500	490	397	397	65	M20	140	18	69	280	206	1050
IE3-K11R 280 M2 G Ex e IIC	FF500	550	427	427	65	M20	140	18	69	280	211	1190

¹⁾ Centre holes to DIN 332-DS ...

Type designation	L k (IM V1)	L k (IM B5)	TB Type Ex e IIC Standard	AG x	LL z	TB Type Ex e IIC VIK	AG x	LL z	AH -	O -	LB	BI BI
IE3-K11R 132 S2 G Ex e IIC	724	584	25 A	143	134	25 AV	143	134	-	M32 x 1.5	4L	35
IE3-K11R 132 SX2 G Ex e IIC	636	596	25 A	143	134	25 AV	143	134	-	M32 x 1.5	4L	35
IE3-K11R 160 M2 G Ex e IIC	739	699	63 A	184	172	100/63 AV	223	214	-	M40 x 1.5	4L	35
IE3-K11R 160 MX2 G Ex e IIC	777	737	63 A	184	172	100/63 AV	223	214	-	M40 x 1.5	4L	35
IE3-K11R 160 L2 G Ex e IIC	777	736	63 A	184	172	100/63 AV	223	214	-	M40 x 1.5	4L	35
IE3-K11R 180 M2C G Ex e IIC	867	827	63 A	184	172	100/63 AV	223	214	-	M40 x 1.5	4L	35
IE3-K11R 200 L2 G Ex e IIC	869	829	100 A	222	214	200 A-SB	335	270	200	M50 x 1.5	4L	40
IE3-K11R 200 LX2 G Ex e IIC	869	829	100 A	222	214	200 A-SB	335	270	200	M50 x 1.5	4L	40
IE3-K11R 225 M2 G Ex e IIC	982	897	100 A	222	214	200 A-SB	335	270	200	M50 x 1.5	8L	45
IE3-K11R 250 M2 G Ex e IIC	1089	1004	200 A	222	214	200 A-SB	335	270	200	M50 x 1.5	8L	55
IE3-K11R 280 S2 G Ex e IIC	1055	1050	200 A	222	214	200 A-SB	335	270	200	M50 x 1.5	8L	55
IE3-K11R 280 M2 G Ex e IIC	1215	1190	200 A	222	214	200 A-SB	335	270	200	M50 x 1.5	8L	55

Three-phase motors with squirrel-cage rotor, Premium Efficiency IE3

Type of explosion protection – Increased safety „e“ („eb“) for operation in Zone 1 according to EN 60079-7 (VIK Recommendation 1, Three-Phase Asynchronous Motors – Technical Requirements 03.2011)

with surface cooling, type of cooling IC 411
Size 315

Type of construction IM B5 [IM 3001], IM V1 [IM 3011]

Flange dimensions, see page 10/6

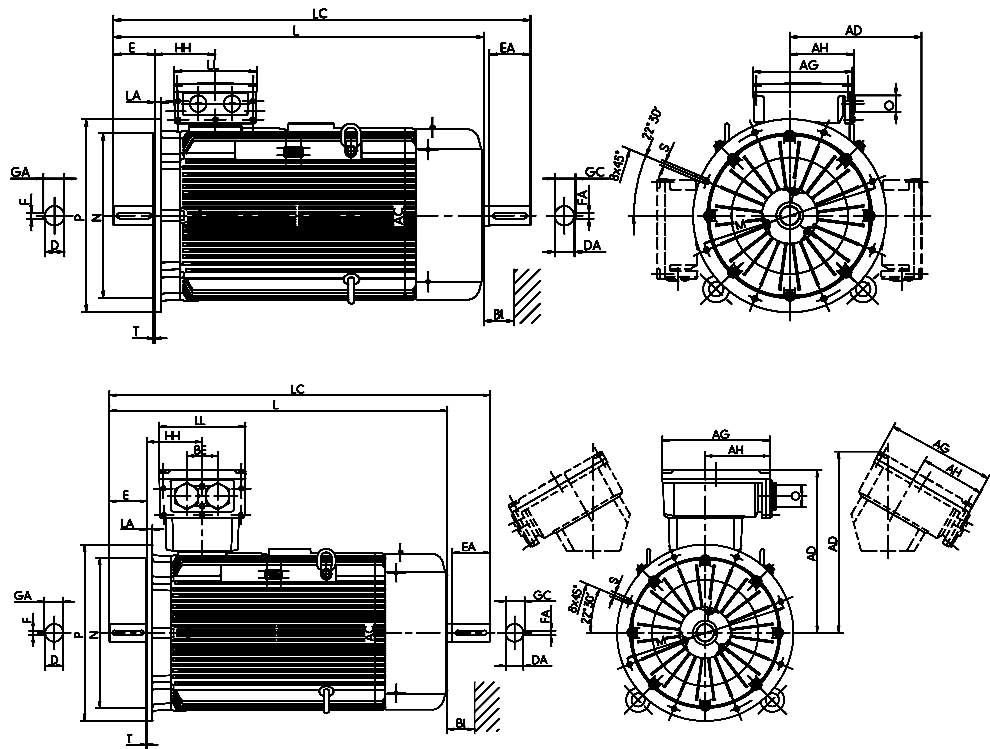

Type designation	Flange	AC	AD	AD VIK	D	DA	DB ¹⁾	E	EA	F	FA	GA	GC	H	HH	L
	g	g1	g1	d	d1		l	l1	u	u1	t	t1	h	A	k	
IE3-K11R 315 S2 Ex e IIC	FF600	550	416	460.5	65	65	M20	140	140	18	18	69	69	315	211	1105
IE3-K11R 315 M2 Ex e IIC	FF600	550	416	460.5	65	65	M20	140	140	18	18	69	69	315	211	1185
IE3-K11R 315 MY2 Ex e IIC	FF600	610	681	680.5	65	65	M20	140	140	18	18	69	69	315	230	1270
IE3-K11R 315 L2 Ex e IIC	FF600	610	681	680.5	65	65	M20	140	140	18	18	69	69	315	230	1390
IE3-K11R 315 LX2 Ex e IIC	FF600	610	681	680.5	65	65	M20	140	140	18	18	69	69	315	230	1510
IE3-K11R 315 S4 Ex e IIC	FF600	550	416	460	80	70	M20	170	140	22	20	85	74.5	315	211	1210
IE3-K11R 315 M4 Ex e IIC	FF600	610	681	681	80	70	M20	170	140	22	20	85	74.5	315	230	1230
IE3-K11R 315 MY4 Ex e IIC	FF600	610	681	681	80	70	M20	170	140	22	20	85	74.5	315	230	1300
IE3-K11R 315 L4 Ex e IIC	FF600	610	681	681	80	70	M20	170	140	22	20	85	74.5	315	230	1540
IE3-K11R 315 LX4 Ex e IIC	FF600	610	681	681	80	70	M20	170	140	22	20	85	74.5	315	230	1540
IE3-K11R 315 S6 Ex e IIC	FF600	610	681	681	80	70	M20	170	140	22	20	85	74.5	315	230	1230
IE3-K11R 315 M6 Ex e IIC	FF600	610	681	681	80	70	M20	170	140	22	20	85	74.5	315	230	1300
IE3-K11R 315 MY6 Ex e IIC	FF600	610	681	681	80	70	M20	170	140	22	20	85	74.5	315	230	1300
IE3-K11R 315 L6 Ex e IIC	FF600	610	681	681	80	70	M20	170	140	22	20	85	74.5	315	230	1420
IE3-K11R 315 LX6 Ex e IIC	FF600	610	681	681	80	70	M20	170	140	22	20	85	74.5	315	230	1420
IE3-K11R 315 S8 Ex e IIC	FF600	550	681	460.5	80	70	M20	170	140	22	20	85	74.5	315	211	1230
IE3-K11R 315 M8 Ex e IIC	FF600	550	681	460.5	80	70	M20	170	140	22	20	85	74.5	315	211	1230
IE3-K11R 315 MY8 Ex e IIC	FF600	610	681	680.5	80	70	M20	170	140	22	20	85	74.5	315	230	1300
IE3-K11R 315 L8 Ex e IIC	FF600	610	681	680.5	80	70	M20	170	140	22	20	85	74.5	315	230	1420
IE3-K11R 315 LX8 Ex e IIC	FF600	610	681	680.5	80	70	M20	170	140	22	20	85	74.5	315	230	1420

¹⁾ Centre holes to DIN 332-DS ...

Type designation	L k (IM V1)	L k (IM B5)	LC k1	LC k1 (IM B5)	TB Type Ex e IIC Standard	AG x	LL z	AH -	TB Type Ex e IIC VIK	AG x	LL z	AH -	O -	LB	BI BI
IE3-K11R 315 S2 Ex e IIC	1215	1105	1273	1273	400 A-SB	415	340	265	630 A	496	390	301	M63 x 1.5	8L	55
IE3-K11R 315 M2 Ex e IIC	1295	1185	1353	1353	400 A-SB	415	340	265	630 A	496	390	301	M63 x 1.5	8L	55
IE3-K11R 315 MY2 Ex e IIC	1390	1270	1448	1448	630 A	496	390	301	630 A	496	390	301	M63 x 1.5	8L	55
IE3-K11R 315 L2 Ex e IIC	1510	1390	1568	1568	630 A	496	390	301	630 A	496	390	301	M63 x 1.5	8L	55
IE3-K11R 315 LX2 Ex e IIC	1620	1510	1688	1688	630 A	496	390	301	630 A	496	390	301	M63 x 1.5	8L	55
IE3-K11R 315 S4 Ex e IIC	1325	1210	1383	1383	400 A-SB	415	340	265	400 A-SB	415	340	265	M63 x 1.5	8L	55
IE3-K11R 315 M4 Ex e IIC	1340	1230	1408	1408	630 A	496	390	301	630 A	496	390	301	M63 x 1.5	8L	55
IE3-K11R 315 MY4 Ex e IIC	1410	1300	1478	1478	630 A	496	390	301	630 A	496	390	301	M63 x 1.5	8L	55
IE3-K11R 315 L4 Ex e IIC	1650	1540	1718	1718	630 A	496	390	301	630 A	496	390	301	M63 x 1.5	8L	55
IE3-K11R 315 LX4 Ex e IIC	1650	1540	1718	1718	630 A	496	390	301	630 A	496	390	301	M63 x 1.5	8L	55
IE3-K11R 315 S6 Ex e IIC	1340	1230	1408	1408	400 A-SB	415	340	265	400 A-SB	415	340	265	M63 x 1.5	8L	55
IE3-K11R 315 M6 Ex e IIC	1410	1300	1478	1478	630 A	496	390	301	630 A	496	390	301	M63 x 1.5	8L	55
IE3-K11R 315 MY6 Ex e IIC	1410	1300	1478	1478	630 A	496	390	301	630 A	496	390	301	M63 x 1.5	8L	55
IE3-K11R 315 L6 Ex e IIC	1530	1420	1598	1598	630 A	496	390	301	630 A	496	390	301	M63 x 1.5	8L	55
IE3-K11R 315 LX6 Ex e IIC	1530	1420	1598	1598	630 A	496	390	301	630 A	496	390	301	M63 x 1.5	8L	55
IE3-K11R 315 S8 Ex e IIC	1340	1230	1408	1408	630 A	496	390	301	630 A	496	390	301	M63 x 1.5	8L	55
IE3-K11R 315 M8 Ex e IIC	1340	1230	1408	1408	630 A	496	390	301	630 A	496	390	301	M63 x 1.5	8L	55
IE3-K11R 315 MY8 Ex e IIC	1410	1300	1478	1478	630 A	496	390	301	630 A	496	390	301	M63 x 1.5	8L	55
IE3-K11R 315 L8 Ex e IIC	1530	1420	1598	1598	630 A	496	390	301	630 A	496	390	301	M63 x 1.5	8L	55
IE3-K11R 315 LX8 Ex e IIC	1530	1420	1598	1598	630 A	496	390	301	630 A	496	390	301	M63 x 1.5	8L	55

Three-phase motors with squirrel-cage rotor, Premium Efficiency IE3

Type of explosion protection – Increased safety „e“ („eb“) for operation in Zone 1 according to EN 60079-7 (VIK Recommendation 1, Three-Phase Asynchronous Motors – Technical Requirements 03.2011)

Low-noise design with direction-dependent fan

with surface cooling, type of cooling IC 411

Size 315

Type of construction IM B5 [IM 3001], IM V1 [IM 3011]

Flange dimensions, see page 10/6

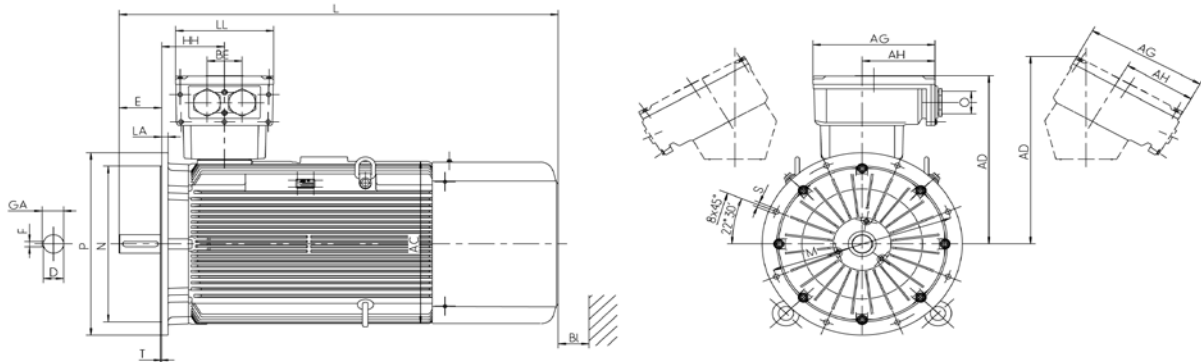

Type designation	Flange B5	AC	AD	AD VIK	D	DA	DB ¹⁾	E	F	GA	H	HH	L
	g	g1	g1	d	d1			l	u	t	h	A	k
IE3-K11R 315 S2 G Ex e IIC	FF600	550	416	460.5	65	-	M20	140	18	69	315	211	1190
IE3-K11R 315 M2 G Ex e IIC	FF600	550	416	460.5	65	65	M20	140	18	69	315	211	1270
IE3-K11R 315 MY2 G Ex e IIC	FF600	610	681	680.5	65	65	M20	140	18	69	315	230	1390
IE3-K11R 315 L2 G Ex e IIC	FF600	610	681	680.5	65	65	M20	140	18	69	315	230	1510
IE3-K11R 315 LX2 G Ex e IIC	FF600	610	681	680.5	65	65	M20	140	18	69	315	230	1630

¹⁾ Centre holes to DIN 332-DS ...

Type designation	L	TB Type	AG	LL		TB Type	AG	LL	AH	O	LB	BI
	k	Ex e IIC	x	z	-	Ex e IIC	x	z	-	-		BI
	(IM V1)	Standard				VIK						
IE3-K11R 315 S2 Ex e IIC	1215	400 A-SB	415	340	265	630 A	496	390	301	M63 x 1.5	8L	55
IE3-K11R 315 M2 Ex e IIC	1295	400 A-SB	415	340	265	630 A	496	390	301	M63 x 1.5	8L	55
IE3-K11R 315 MY2 Ex e IIC	1510	630 A	496	390	301	630 A	496	390	301	M63 x 1.5	8L	55
IE3-K11R 315 L2 Ex e IIC	1630	630 A	496	390	301	630 A	496	390	301	M63 x 1.5	8L	55
IE3-K11R 315 LX2 Ex e IIC	1740	630 A	496	390	301	630 A	496	390	301	M63 x 1.5	8L	55

Three-phase motors with squirrel-cage rotor, Premium Efficiency IE3

Type of explosion protection – Increased safety „e“ („eb“) for operation in Zone 1 according to EN 60079-7 (VIK Recommendation 1, Three-Phase Asynchronous Motors – Technical Requirements 03.2011)

with surface cooling, type of cooling IC 411

Type of construction IM B5 [IM 3001], IM V1 [IM 3011]

Size 355 to 400, 2-pole

Flange dimensions, see page 10/6

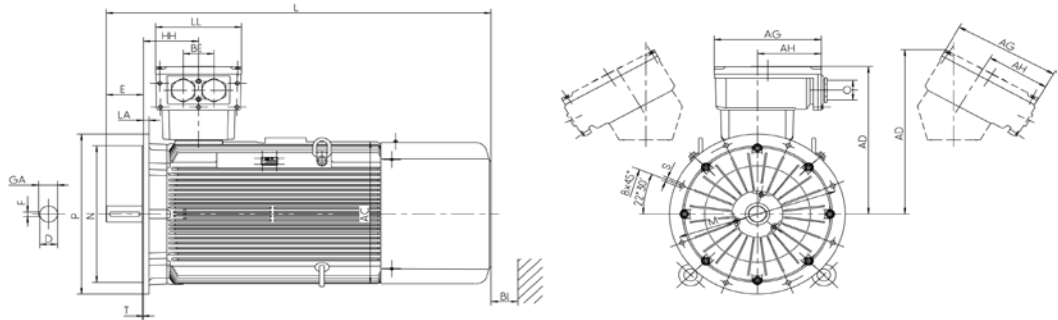

Type of construction IM B5 [IM 3001], IM V1 [IM 3011]

Size 355 to 400, 4- to 8-pole

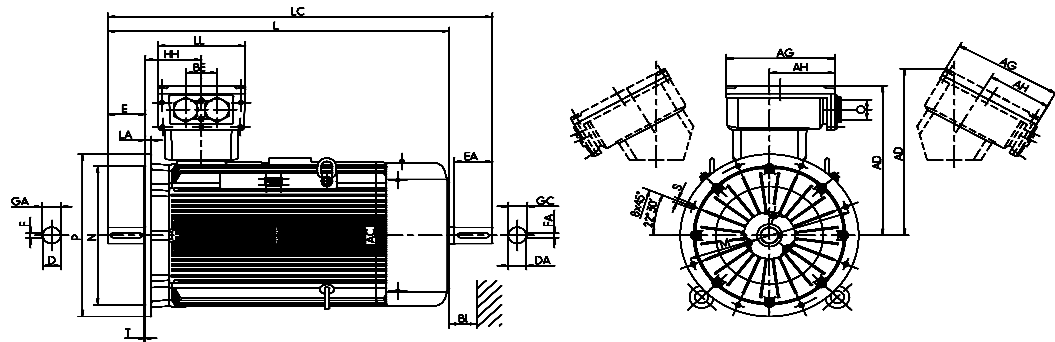

Type designation	Flange size	AC	AD	AD ^{*)}	D	DA	DB ^{*)}	E	EA	F	FA	GA	GC	H	HA	L	LC	TB Type	AG	LL	AH	BE	O	BI
		g	g1	g1	d	d1		l	l1	u	u1	t	t1	h	c	k	k1	Ex e IIC Standard/ VIK	x	z	-	-	r	BI
IE3-K12R 355 M2G Ex e IIC	FF740	715	736	811	80	-	M20	170	-	22	-	85	-	355	250	1530	-	630 A	496	390	301	140	M75 x 1.5	60
IE3-K12R 355 MX2G Ex e IIC	FF740	715	759	817	80	-	M21	170	-	22	-	85	-	355	327	1730	-	1000 A	615	474	385	200	M75 x 1.5	60
IE3-K12R 355 LY2G, L2G Ex e IIC	FF740	715	759	817	80	-	M22	170	-	22	-	85	-	355	327	1730	-	1000 A	615	474	385	200	M75 x 1.5	60
IE3-W42R 355 MX2G Ex e IIC	FF 740	715	719	817	80	-	M20	170	-	22	-	85	-	355		1730	-	1000 A	615	474	385	200	M75 x 1.5	60
IE3-W42R 355 L2G Ex e IIC	FF 740	715	719	817	80	-	M20	170	-	22	-	85	-	355		1730	-	1000 A	615	474	385	200	M75 x 1.5	60
IE3-K11R 355 M4 Ex e IIC	FF740	715	736	811	100	80	M24	210	170	28	22	106	85	355	250	1570	1755	630 A	496	390	301	140	M63 x 1.5	60
IE3-K11R 355 MX4 Ex e IIC	FF740	715	759	817	100	80	M24	210	170	28	22	106	85	355	327	1770	1955	1000 A	615	474	385	200	M75 x 1.5	60
IE3-K12R 355 M6 Ex e IIC	FF740	715	736	811	100	80	M24	210	170	28	22	106	85	355	250	1570	1755	630 A	496	390	301	140	M63 x 1.5	60
IE3-K12R 355 MX6 Ex e IIC	FF740	715	736	811	100	80	M24	210	170	28	22	106	85	355	365	1770	1955	630 A	496	390	301	140	M63 x 1.5	60
IE3-K12R 355 L6 Ex e IIC	FF740	715	729	817	100	80	M24	210	170	28	22	106	85	355	327	1770	1955	1000 A	615	474	385	200	M75 x 1.5	60
IE3-K12R 355 M8 Ex e IIC	FF740	715	736	811	100	80	M24	210	170	28	22	106	85	355	250	1570	1755	630 A	496	390	301	140	M75 x 1.5	60
IE3-K12R 355 MX8 Ex e IIC	FF740	715	736	811	100	80	M24	210	170	28	22	106	85	355	265	1770	1955	630 A	496	390	301	140	M75 x 1.5	60
IE3-K12R 355 L8 Ex e IIC	FF740	715	729	817	100	80	M24	210	170	28	22	106	85	355	327	1770	1955	1000 A	615	474	385	200	M75 x 1.5	60
IE3-W42R 355 MX6, 8 Ex e IIC	FF 740	715	733	811	100	80	M24	210	170	28	22	106	85	355		1770	1955	630 A	496	390	301	140	M75 x 1.5	60
IE3-W42R 355 MX4 Ex e IIC	FF 740	715	719	817	100	80	M24	210	170	28	22	106	85	355		1770	1955	1000 A	615	474	385	200	M75 x 1.5	60
IE3-W42R 355 L4 Ex e IIC	FF 740	715	719	817	100	80	M24	210	170	28	22	106	85	355		1770	1955	1000 A	615	474	385	200	M75 x 1.5	60
IE3-W42R 355 L6, 8 Ex e IIC	FF 740	715	719	817	100	80	M24	210	170	28	22	106	85	355		1770	1955	1000 A	615	474	385	200	M75 x 1.5	60
IE3-W42R 400 M2G, MX2G Ex e IIC	FF940	810	813	873	80	-	M20	170	-	22	-	85	-	400		1963	-	1000 A	615	474	385	200	M80 x 1.5	100
IE3-W42R 400 L2G Ex e IIC	FF940	810	813	873	80	-	M20	170	-	22	-	85	-	400		1963	-	1000 A	615	474	385	200	M80 x 1.5	100
IE3-W42R 400 M, MX 4, 6, 8 Ex e IIC	FF940	810	813	873	110	80	M24	210	170	28	22	116	85	400		2003	2201	1000 A	615	474	385	200	M80 x 1.5	100
IE3-W42R 400 L4, 6, 8 Ex e IIC	FF940	810	813	873	110	80	M24	210	170	28	22	116	85	400		2003	2201	1000 A	615	474	385	200	M80 x 1.5	100

^{*)} Centre holes to DIN 332-DS ...

^{**)} Terminal box inclined left/right

Three-phase motors with squirrel-cage rotor, High Efficiency IE2

Type of explosion protection – Increased safety „e“ („eb“) for operation in Zone 1 according to EN 60079-7 (VIK Recommendation 1, Three-Phase Asynchronous Motors – Technical Requirements 03.2011)

with surface cooling, type of cooling IC 411

Type of construction IM B3 [IM 1001]

Flange dimensions, see page 10/6

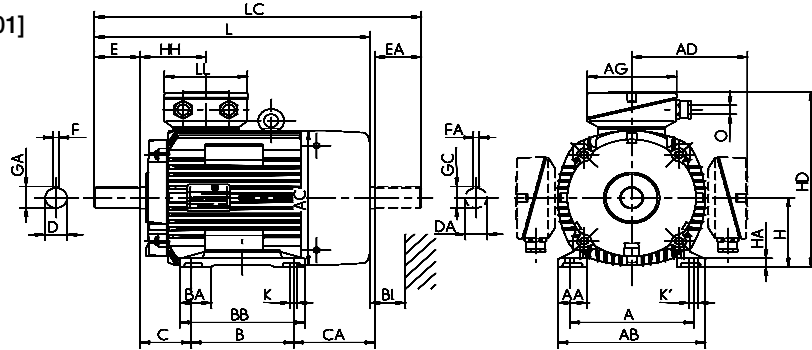

Type designation	Flange size	A	AA	AB	AC	AD	AD	B	BA	BB	C	CA	D	DA	DB ^{*)}	E	EA	F	FA
		b	n	f	g	g1	g1	a	m	e	w1	w2	d	d1	l	l1	u	u1	
IE2-KPR 80 K2 Ex e IIC	A200	125	26	152	157	138	138	100	-	124	50	80	19	19	M6	40	40	6	6
IE2-KPR 80 G2, 4 Ex e IIC	A200	125	26	152	157	138	138	100	-	146	50	102	19	19	M6	40	40	6	6
IE2-KPR 90 S2, 4, 6 Ex e IIC	A200	140	40	178	177	146	146	100	-	130	56	120	24	24	M8	50	50	8	8
IE2-KPR 90 L2 Ex e IIC	A200	140	40	178	177	146	146	125	-	155	56	95	24	24	M8	50	50	8	8
IE2-KPR 90 L4, 6 Ex e IIC	A200	140	40	178	177	146	146	125	-	155	56	125	24	24	M8	50	50	8	8
IE2-KPR 100 L2, S8	A250	160	42	193	196	155	155	140	-	175	63	102	28	28	M10	60	60	8	8
IE2-KPR 100 L4 Ex e IIC	A250	160	42	193	196	155	155	140	-	175	63	136	28	28	M10	60	60	8	8
IE2-KPR 100 LX4 Ex e IIC	A250	160	42	193	196	155	155	140	-	175	63	166	28	28	M10	60	60	8	8
IE2-KPR 100 LX6 Ex e IIC	A250	160	42	193	196	155	155	140	-	175	63	136	28	28	M10	60	60	8	8
IE2-KPER 112 MX2 Ex e IIC	A250	190	52	225	196	155	155	140	-	180	70	129	28	28	M10	60	60	8	8
IE2-KPER 112 MZ4 Ex e IIC	A250	190	52	225	196	155	155	140	-	180	70	199	28	28	M10	60	60	8	8
IE2-KPER 112 MV6 Ex e IIC	A250	190	52	225	196	155	155	140	-	180	70	159	28	28	M10	60	60	8	8
IE2-K11R 112 M2 Ex e IIC	A250	190	45	226	217	220	220	140	42	172	70	192	28	28	M10	60	60	8	8
IE2-K11R 112 M4 Ex e IIC	A250	190	45	226	217	220	220	140	42	172	70	192	28	28	M10	60	60	8	8
IE2-K11R 112 M6 Ex e IIC	A250	190	45	226	217	220	220	140	42	172	70	192	28	28	M10	60	60	8	8
IE2-K11R 132 S2 Ex e IIC	A300	216	50	256	217	220	220	140	55	180	89	173	38	32	M12	80	80	10	10
IE2-K11R 132 SX2 Ex e IIC	A300	216	50	256	258	246	246	140	47	180	89	176	38	32	M12	80	80	10	10
IE2-K11R 132 S4 Ex e IIC	A300	216	50	256	258	246	246	140	47	180	89	176	38	32	M12	80	80	10	10
IE2-K11R 132 S6 Ex e IIC	A300	216	50	256	217	220	220	140	55	180	89	173	38	32	M12	80	80	10	10
IE2-K11R 132 M4 Ex e IIC	A300	216	50	256	258	246	246	178	47	218	89	186	38	38	M12	80	80	10	10
IE2-K11R 132 M6 Ex e IIC	A300	216	50	256	217	220	220	178	55	218	89	135	38	32	M12	80	80	10	10
IE2-K11R 132 MX6 Ex e IIC	A300	216	50	256	258	246	246	178	47	218	89	186	38	38	M12	80	80	10	10
IE2-K11R 160 M2 Ex e IIC	A350	254	55	296	313	249	275	210	60	257	108	148	42	38	M16	110	110	12	10
IE2-K11R 160 M4 Ex e IIC	A350	254	55	296	313	249	275	210	60	257	108	148	42	38	M16	110	110	12	10
IE2-K11R 160 M8 Ex e IIC	A350	254	55	296	258	256	256	210	60	257	108	185	42	38	M16	110	80	12	10
IE2-K11R 160 M6 Ex e IIC	A350	254	55	296	258	256	256	210	60	257	108	185	42	38	M16	110	80	12	10
IE2-K11R 160 MX2 Ex e IIC	A350	254	55	296	313	249	275	210	56	257	108	186	42	42	M16	110	110	12	12
IE2-K11R 160 L2 Ex e IIC	A350	254	55	296	313	249	275	254	60	301	108	142	42	42	M16	110	110	12	12
IE2-K11R 160 L4 Ex e IIC	A350	254	55	296	313	249	275	254	60	301	108	200	42	42	M16	110	110	12	12
IE2-K11R 160 L6 Ex e IIC	A350	254	55	296	313	249	275	254	60	301	108	142	42	42	M16	110	110	12	12
IE2-K11R 180 M2 Ex e IIC	A350	279	62	328	351	268	294	241	65	288	121	169	48	48	M16	110	110	14	14
IE2-K11R 180 M4 Ex e IIC	A350	279	62	328	351	268	294	241	65	288	121	214	48	42	M16	110	110	14	12
IE2-K11R 180 L4 Ex e IIC	A350	279	62	328	351	268	294	279	65	326	121	176	48	48	M16	110	110	14	14
IE2-K11R 180 L6 Ex e IIC	A350	279	62	328	351	268	294	279	65	326	121	176	48	42	M16	110	110	14	12
IE2-K11R 200 L2 Ex e IIC	A400	318	70	372	351	268	294	305	70	360	133	138	55	48	M20	110	110	16	14
IE2-K11R 200 LX2 Ex e IIC	A400	356	70	372	390	311	375	305	70	360	133	193	55	48	M20	110	110	16	16
IE2-K11R 200 L4 Ex e IIC	A400	318	70	372	390	311	375	305	70	360	133	193	55	48	M20	110	110	16	14
IE2-K11R 200 LX6 Ex e IIC	A400	318	70	372	390	311	375	305	70	360	133	193	55	48	M20	110	110	16	14
IE2-K11R 200 L6 Ex e IIC	A400	318	70	372	351	268	294	305	70	360	133	138	55	48	M20	110	110	16	14
IE2-K11R 225 M2 Ex e IIC	A450	356	75	413	440	300	300	311	75	368	149	267	55	55	M20	110	110	16	16
IE2-K11R 225 S4 Ex e IIC	A450	356	75	413	440	300	300	311	75	343	149	196	60	55	M20	140	110	18	16
IE2-K11R 225 M4 Ex e IIC	A450	356	75	413	440	300	300	311	75	368	149	267	60	55	M20	140	110	18	16
IE2-K11R 225 S8 Ex e IIC	A450	356	75	413	390	311	375	286	75	343	149	196	60	55	M20	140	110	18	16
IE2-K11R 225 M6 Ex e IIC	A450	356	75	413	440	324	406	311	75	368	149	267	60	55	M20	140	110	18	16
IE2-K11R 225 M8 Ex e IIC	A450	356	75	413	440	324	406	311	75	368	149	267	60	55	M20	140	110	18	16
IE2-K11R 250 M2 Ex e IIC	A550	406	84	469	490	386	403	349	84	374	168	275	60	60	M20	140	140	18	18
IE2-K11R 250 M4 Ex e IIC	A550	406	84	469	490	386	403	349	84	412	168	275	65	55	M20	140	110	18	16
IE2-K11R 250 M6 Ex e IIC	A550	406	84	469	490	386	403	349	84	412	168	275	65	55	M20	140	110	18	16
IE2-K11R 280 S2 Ex e IIC	A550	457	88	522	490	386	403	368	96	431	190	234	65	60	M20	140	140	18	18
IE2-K11R 280 M2 Ex e IIC	A550	457	94	522	490	386	403	419	96	482	190	229	65	65	M20	140	140	18	18
IE2-K11R 280 S4 Ex e IIC	A550	457	88	522	550	386	403	368	96	431	190	234	75	65	M20	140	140	20	18
IE2-K11R 280 M4 Ex e IIC	A550	457	88	522	550	386	403	419	94	482	190	384	75	65	M20	140	140	20	18
IE2-K11R 280 S6 Ex e IIC	A550	457	94	522	490	386	403	368	96	431	190	229	75	65	M20	140	140	20	18
IE2-K11R 280 M6 Ex e IIC	A550	457	88	522	550	416	433	419	94	482	190	384	75	65	M20	140	140	20	18
IE2-K11R 280 S8 Ex e IIC	A550	457	94	522	490	386	403	368	96	431	190	229	75	65	M20	140	140	20	18
IE2-K11R 280 M8 Ex e IIC	A550	457	88	522	550	416	433	419	94	482	190	384	75	65	M20	140	140	20	18

^{*)} Centre holes to DIN 332-DS ...

Three-phase motors with squirrel-cage rotor, High Efficiency IE2

Type of explosion protection – Increased safety „e“ („eb“) for operation in Zone 1 according to EN 60079-7 (VIK Recommendation 1, Three-Phase Asynchronous Motors – Technical Requirements 03.2011)

with surface cooling, type of cooling IC 411

Type of construction

IM B35 [IM 2001]

Flange dimensions, see page 10/6

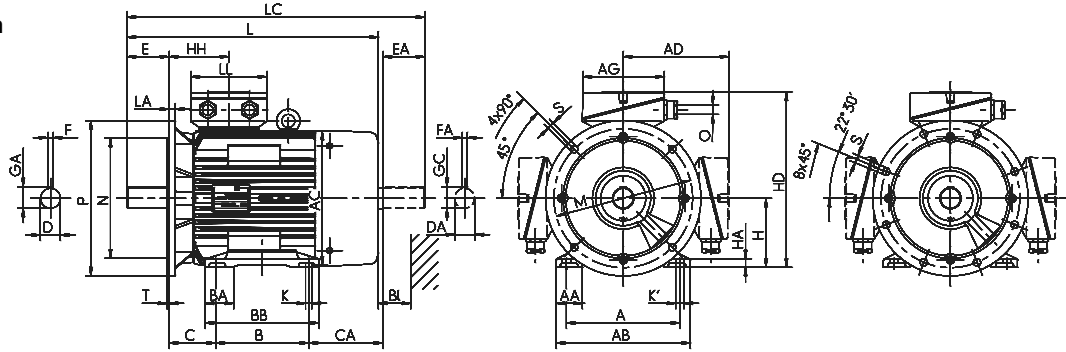

Type designation	GA	GC	H	HA	HD	HD ^{*)}	HD	HH	HH	K	K'	L	LC	TB Type	AG	LL	TB Type	AG	LL	AH	O	LB	BI		
																								t	t1
IE2-KPR 80 K2 Ex e IIC	21.5	21.5	80	9	218	***)	218	79	79	10	10	267	310	KA 05 - 13	104	112	KA 05 - 13	104	112	-	-	M20 x 1.5	4L	16	
IE2-KPR 80 G2, 4 Ex e IIC	21.5	21.5	80	9	218	***)	218	79	79	10	10	289	332	KA 05 - 13	104	112	KA 05 - 13	104	112	-	-	M20 x 1.5	4L	16	
IE2-KPR 90 S2, 4, 6 Ex e IIC	27	27	90	10.5	236	***)	236	84	123	10	10	323	376	KA 05 - 13	104	112	KA 05 - 13	104	112	-	-	M25 x 1.5	4L	18	
IE2-KPR 90 L2 Ex e IIC	27	27	90	10.5	236	***)	236	84	123	10	10	323	376	KA 05 - 13	104	112	KA 05 - 13	104	112	-	-	M25 x 1.5	4L	18	
IE2-KPR 90 L4, 6 Ex e IIC	27	27	90	10.5	236	***)	236	84	123	10	10	353	406	KA 05 - 13	104	112	KA 05 - 13	104	112	-	-	M25 x 1.5	4L	18	
IE2-KPR 100 L2, S8	31	31	100	13	255	***)	255	86	86	12	12	359	425	KA 05 - 13	104	112	KA 05 - 13	104	112	-	-	M25 x 1.5	4L	20	
IE2-KPR 100 L4 Ex e IIC	31	31	100	13	255	***)	255	86	86	12	12	393	459	KA 05 - 13	104	112	KA 05 - 13	104	112	-	-	M25 x 1.5	4L	20	
IE2-KPR 100 LX4 Ex e IIC	31	31	100	13	255	***)	255	86	86	12	12	423	489	KA 05 - 13	104	112	KA 05 - 13	104	112	-	-	M25 x 1.5	4L	20	
IE2-KPR 100 LX6 Ex e IIC	31	31	100	13	255	***)	255	86	86	12	12	393	459	KA 05 - 13	104	112	KA 05 - 13	104	112	-	-	M25 x 1.5	4L	20	
IE2-KPER 112 MX2 Ex e IIC	31	31	112	18	267	***)	267	86	86	12	12	393	459	KA 05 - 13	104	112	KA 05 - 13	104	112	-	-	M25 x 1.5	4L	20	
IE2-KPER 112 MZ4 Ex e IIC	31	31	112	18	267	***)	267	86	86	12	12	463	529	KA 05 - 13	104	112	KA 05 - 13	104	112	-	-	M25 x 1.5	4L	20	
IE2-KPER 112 MV6 Ex e IIC	31	31	112	18	267	***)	267	86	86	12	12	423	489	KA 05 - 13	104	112	KA 05 - 13	104	112	-	-	M25 x 1.5	4L	20	
IE2-K11R 112 M2 Ex e IIC	31	31	112	15	333	236.5	333	108	108	12	12	459	522	25 A	143	134	25 AV	143	134	-	-	M32 x 1.5	4L	35	
IE2-K11R 112 M4 Ex e IIC	31	31	112	15	333	236.5	333	108	108	12	12	459	522	25 A	143	134	25 AV	143	134	-	-	M32 x 1.5	4L	35	
IE2-K11R 112 M6 Ex e IIC	31	31	112	15	333	236.5	333	108	108	12	12	459	522	25 A	143	134	25 AV	143	134	-	-	M32 x 1.5	4L	35	
IE2-K11R 132 S2 Ex e IIC	41	35	132	16	353	256.5	353	108	108	12	12	479	562	25 A	143	134	25 AV	143	134	-	-	M32 x 1.5	4L	35	
IE2-K11R 132 SX2 Ex e IIC	41	35	132	15	374	279	374	114	114	12	12	481	565	25 A	143	134	25 AV	143	134	-	-	M32 x 1.5	4L	35	
IE2-K11R 132 S4 Ex e IIC	41	35	132	15	374	279	374	114	114	12	12	481	565	25 A	143	134	25 AV	143	134	-	-	M32 x 1.5	4L	35	
IE2-K11R 132 S6 Ex e IIC	41	35	132	16	353	256.5	353	108	108	12	12	479	562	25 A	143	134	25 AV	143	134	-	-	M32 x 1.5	4L	35	
IE2-K11R 132 M4 Ex e IIC	41	41	132	15	374	279	374	114	114	12	12	529	613	25 A	143	134	25 AV	143	134	-	-	M32 x 1.5	4L	35	
IE2-K11R 132 M6 Ex e IIC	41	35	132	16	353	256.5	353	108	108	12	12	529	612	25 A	143	134	25 AV	143	134	-	-	M32 x 1.5	4L	35	
IE2-K11R 132 MX6 Ex e IIC	41	41	132	15	374	279	374	114	114	12	12	529	613	25 A	143	134	25 AV	143	134	-	-	M32 x 1.5	4L	35	
IE2-K11R 160 M2 Ex e IIC	45	41	160	18	409	336	435	138	138	15	20	571	686	63 A	184	172	100/63 AV	223	214	-	-	M40 x 1.5	4L	35	
IE2-K11R 160 M4 Ex e IIC	45	41	160	18	409	336	435	138	138	15	20	571	686	63 A	184	172	100/63 AV	223	214	-	-	M40 x 1.5	4L	35	
IE2-K11R 160 M8 Ex e IIC	45	41	160	18	417	307	417	114	114	15	15	609	693	25 A	143	134	25 AV	143	134	-	-	M32 x 1.5	4L	35	
IE2-K11R 160 M6 Ex e IIC	45	41	160	18	417	307	417	114	114	15	15	609	693	25 A	143	134	25 AV	143	134	-	-	M32 x 1.5	4L	35	
IE2-K11R 160 MX2 Ex e IIC	45	45	160	18	409	336	435	138	138	15	20	609	724	63 A	184	172	100/63 AV	223	214	-	-	M40 x 1.5	4L	35	
IE2-K11R 160 L2 Ex e IIC	45	45	160	18	409	336	435	138	138	15	20	609	724	63 A	184	172	100/63 AV	223	214	-	-	M40 x 1.5	4L	35	
IE2-K11R 160 L4 Ex e IIC	45	45	160	18	409	336	435	138	138	15	20	667	783	63 A	184	172	100/63 AV	223	214	-	-	M40 x 1.5	4L	35	
IE2-K11R 160 L6 Ex e IIC	45	45	160	18	409	336	435	138	138	15	20	609	724	63 A	184	172	100/63 AV	223	214	-	-	M40 x 1.5	4L	35	
IE2-K11R 180 M2 Ex e IIC	51.5	51.5	180	20	447	369	473	147	147	15	20	635	751	63 A	184	172	100/63 AV	223	214	-	-	M40 x 1.5	4L	35	
IE2-K11R 180 M4 Ex e IIC	51.5	45	180	20	447	369	473	147	147	15	20	680	796	63 A	184	172	100/63 AV	223	214	-	-	M40 x 1.5	4L	35	
IE2-K11R 180 L4 Ex e IIC	51.5	51.5	180	20	447	369	473	147	147	15	20	680	796	63 A	184	172	100/63 AV	223	214	-	-	M40 x 1.5	4L	35	
IE2-K11R 180 L6 Ex e IIC	51.5	45	180	20	447	369	473	147	147	15	20	680	796	63 A	184	172	100/63 AV	223	214	-	-	M40 x 1.5	4L	35	
IE2-K11R 200 L2 Ex e IIC	59	51.5	200	22	494	389	520	147	147	19	25	680	796	100/63 AV	223	214	100/63 AV	223	214	-	-	M50 x 1.5	4L	35	
IE2-K11R 200 LX2 Ex e IIC	59	59	200	22	511	417	578	168	168	19	25	727	851	100 A	222	214	200 A-SB	335	270	200	-	-	M50 x 1.5	4L	35
IE2-K11R 200 L4 Ex e IIC	59	51.5	200	22	511	417	578	168	168	19	25	727	851	100 A	222	214	200 A-SB	335	270	200	-	-	M50 x 1.5	4L	35
IE2-K11R 200 LX6 Ex e IIC	59	51.5	200	22	511	417	578	168	168	19	25	727	851	100 A	222	214	200 A-SB	335	270	200	-	-	M50 x 1.5	4L	35
IE2-K11R 200 L6 Ex e IIC	59	51.5	200	22	494	389	520	147	147	19	25	680	796	63 A	184	172	100/63 AV	223	214	-	-	M50 x 1.5	4L	35	
IE2-K11R 225 M2 Ex e IIC	64	59	225	25	527	450	605	177	177	19	25	832	947	100 A	222	214	200 A-SB	335	270	200	-	-	M50 x 1.5	8L	45
IE2-K11R 225 S4 Ex e IIC	64	59	225	25	551	450	631	177	177	19	25	757	881	100 A	222	214	200 A-SB	335	270	200	-	-	M50 x 1.5	8L	45
IE2-K11R 225 M4 Ex e IIC	64	59	225	25	551	450	631	177	177	19	25	862	977	100 A	222	214	200 A-SB	335	270	200	-	-	M50 x 1.5	8L	45
IE2-K11R 225 S8 Ex e IIC	64	59	225	25	536	417	604	168	168	19	25	757	881	100 A	222	214	200 A-SB	335	270	200	-	-	M50 x 1.5	8L	45
IE2-K11R 225 M6 Ex e IIC	64	59	225	25	549	450	631	177	177	19	25	862	977	100 A	222	214	200 A-SB	335	270	200	-	-	M50 x 1.5	8L	45
IE2-K11R 225 M8 Ex e IIC	64	59	225	25	549	450	631	177	177	19	25	862	977	100 A	222	214	200 A-SB	335	270	200	-	-	M50 x 1.5	8L	45
IE2-K11R 250 M2 Ex e IIC	64	64	250	28	549	507	653	206	206	24	30	924	1072	200 A	290	252	200 A-SB	335	270	200	-	-	M63 x 1.5	8L	55
IE2-K11R 250 M4 Ex e IIC	69	59	250	28	636	507	653	206	206	24	30	924	1042	200 A	290	252	200 A-SB	335	270	200	-	-	M63 x 1.5	8L	50
IE2-K11R 250 M6 Ex e IIC	69	59	250	28	636	507	653</																		

Three-phase motors with squirrel-cage rotor, High Efficiency IE2

Type of explosion protection – Increased safety „e“ („eb“) for operation in Zone 1 according to EN 60079-7 (VIK Recommendation 1, Three-Phase Asynchronous Motors – Technical Requirements 03.2011)

Low-noise design with direction-dependent fan

with surface cooling, type of cooling IC 411

Type of construction IM B3 [IM 1001]

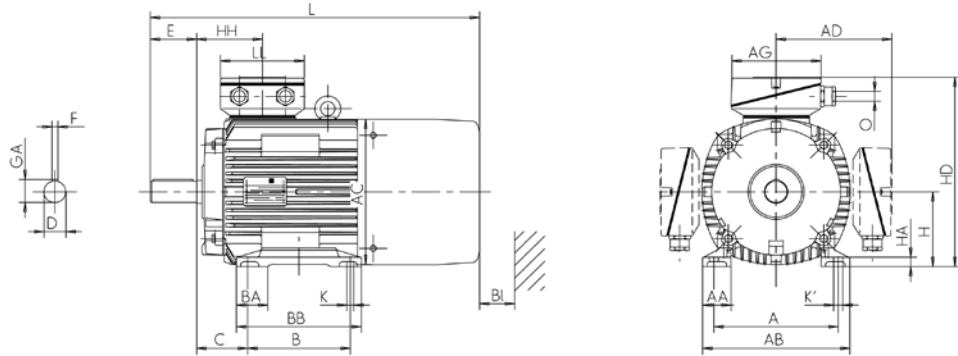

Type designation	Flange size	A	AA	AB	AC	AD	AD	B	BA	BB	C	D	DB ¹⁾	E	F
		b	n	f	g	g1	VIK g1	a	m	e	w1	d		l	u
IE2-K11R 132 S2G Ex e IIC	A300	216	50	256	217	220	220	140	55	180	89	38	M12	80	10
IE2-K11R 132 SX2G Ex e IIC	A300	216	50	256	258	246	246	140	47	180	89	38	M12	80	10
IE2-K11R 160 MG2 Ex e IIC	A350	254	55	296	313	249	275	210	60	257	108	42	M16	110	12
IE2-K11R 160 MX2G Ex e IIC	A350	254	55	296	313	249	275	210	56	257	108	42	M16	110	12
IE2-K11R 160 L2G Ex e IIC	A350	254	55	296	313	249	275	254	60	301	108	42	M16	110	12
IE2-K11R 180 M2G Ex e IIC	A350	279	62	328	351	268	294	241	65	288	121	48	M16	110	14
IE2-K11R 200 L2G Ex e IIC	A400	318	70	372	351	268	294	305	70	360	133	55	M20	110	16
IE2-K11R 200 LX2G Ex e IIC	A400	356	70	372	390	311	375	305	70	360	133	55	M20	110	16
IE2-K11R 225 M2G Ex e IIC	A450	356	75	413	440	300	300	311	75	368	149	55	M20	110	16
IE2-K11R 250 M2G Ex e IIC	A550	406	84	469	490	386	403	349	84	374	168	60	M20	140	18
IE2-K11R 280 S2G Ex e IIC	A550	457	88	522	490	386	403	368	96	431	190	65	M20	140	18
IE2-K11R 280 M2G Ex e IIC	A550	457	94	522	490	386	403	419	96	482	190	65	M20	140	18

¹⁾ Centre holes to DIN 332-DS ...

Three-phase motors with squirrel-cage rotor, High Efficiency IE2

Type of explosion protection – Increased safety „e“ („eb“) for operation in Zone 1 according to EN 60079-7 (VIK Recommendation 1, Three-Phase Asynchronous Motors – Technical Requirements 03.2011)

Low-noise design with direction-dependent fan

with surface cooling, type of cooling IC 411

Type of construction IM B35 [IM 2001]

Flange dimensions, see page 10/6

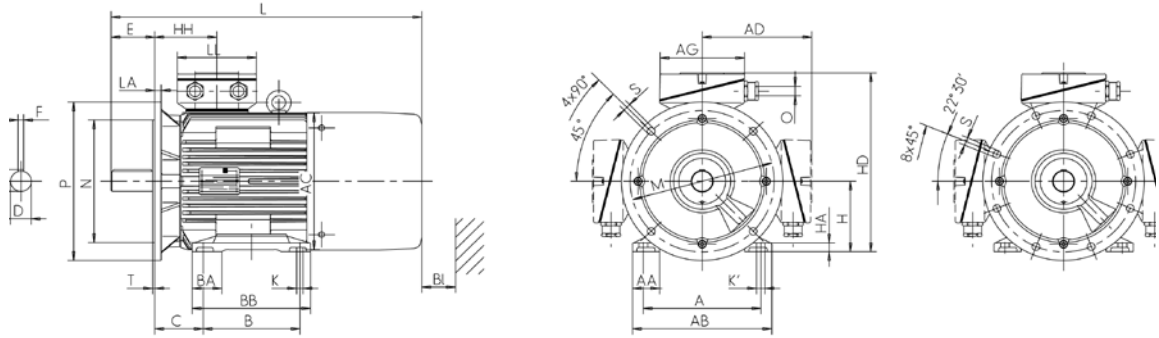

Type designation	GA	H	HA	HD	HD ^{**})	HD	HH	K	K'	L	TB Type	AG	LL	TB Type	AG	LL	AH	O	LB	BI
	t	h	c	p	p	p	A	s	s'	k	Ex e IIC Standard	x	z	Ex e IIC VIK	x	z	-	-		BI
IE2-K11R 132 S2G Ex e IIC	41	132	16	353	256.5	353	108	12	12	583	25 A	143	134	25 AV	143	134	-	M32 x 1.5	4L	35
IE2-K11R 132 SX2G Ex e IIC	41	132	15	374	279	374	114	12	12	595	25 A	143	134	25 AV	143	134	-	M32 x 1.5	4L	35
IE2-K11R 160 M2G Ex e IIC	45	160	18	409	336	435	138	15	20	698	63 A	184	172	100/63 AV	223	214	-	M40 x 1.5	4L	35
IE2-K11R 160 MX2G Ex e IIC	45	160	18	409	336	435	138	15	20	609	63 A	184	172	100/63 AV	223	214	-	M40 x 1.5	4L	35
IE2-K11R 160 L2G Ex e IIC	45	160	18	409	336	435	138	15	20	736	63 A	184	172	100/63 AV	223	214	-	M40 x 1.5	4L	35
IE2-K11R 180 M2G Ex e IIC	51.5	180	20	447	369	473	147	15	20	781	63 A	184	172	100/63 AV	223	214	-	M40 x 1.5	4L	35
IE2-K11R 200 L2G Ex e IIC	59	200	22	494	389	520	147	19	25	826	100/63 AV	223	214	100/63 AV	223	214	-	M50 x 1.5	4L	35
IE2-K11R 200 LX2G Ex e IIC	59	200	22	511	417	578	168	19	25	790	100 A	222	214	200 A-SB	335	270	200	M50 x 1.5	4L	35
IE2-K11R 225 M2G Ex e IIC	59	225	25	527	450	605	177	19	25	897	100 A	222	214	200 A-SB	335	270	200	M50 x 1.5	8L	45
IE2-K11R 250 M2G Ex e IIC	64	250	28	549	507	653	206	24	30	1004	200 A	290	252	200 A-SB	335	270	200	M63 x 1.5	8L	55
IE2-K11R 280 S2G Ex e IIC	69	280	32	666	537	683	206	24	30	1004	200 A	290	252	200 A-SB	335	270	200	M63 x 1.5	8L	55
IE2-K11R 280 M2G Ex e IIC	69	280	32	696	575	713	206	24	30	1004	200 A	290	252	200 A-SB	335	270	200	M63 x 1.5	8L	50

** Terminal box left/right

Three-phase motors with squirrel-cage rotor, High Efficiency IE2

Type of explosion protection – Increased safety „e“ („eb“) for operation in Zone 1 according to EN 60079-7 (VIK Recommendation 1, Three-Phase Asynchronous Motors – Technical Requirements 03.2011)

with surface cooling, type of cooling IC 411
Size 315 to 355

Type of construction IM B3 [IM 1001]

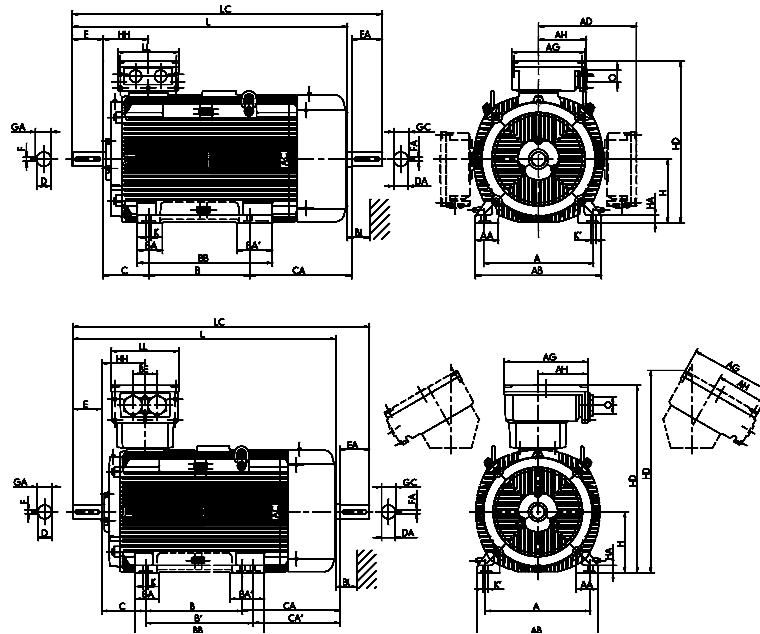

Type designation	Flange size	A	AA	AB	AC	AD	AD	B	BA	BA'	BB	C	CA	D	DA	DB ¹⁾	E	EA	F	FA
		b	n	f	g	g1	g1	a	m	m1	e	w1	w2	d	d1	l	l1	u	u1	
IE2-K11R 315 S2 Ex e IIC	A660	508	126	590	550	416	460.5	406	120	-	503	216	316	65	65	M20	140	140	18	18
IE2-K11R 315 M2 Ex e IIC	A660	508	126	590	550	416	460.5	457	120	150	554	216	320	65	65	M20	140	140	18	18
IE2-K11R 315 MX2 Ex e IIC	A660	508	126	590	550	416	460.5	457	120	150	554	216	400	65	65	M20	140	140	18	18
IE2-K11R 315 MY2 Ex e IIC	A660	508	110	590	610	494	680.5	457	120	-	573	216	495	65	65	M20	140	140	18	18
IE2-K11R 315 L2 Ex e IIC	A660	508	110	590	610	494	680.5	508	120	-	624	216	564	65	65	M20	140	140	18	18
IE2-K11R 315 LX2 Ex e IIC	A660	508	110	590	610	494	680.5	508	120	-	624	216	684	65	65	M20	140	140	18	18
IE2-K11R 315 S4 Ex e IIC	A660	508	132	590	550	416	460.5	406	120	-	554	216	371	80	70	M20	170	140	22	20
IE2-K11R 315 M4 Ex e IIC	A660	508	126	590	550	416	460.5	457	120	150	554	216	320	80	70	M20	170	140	22	20
IE2-K11R 315 MX4 Ex e IIC	A660	508	126	590	550	416	460.5	457	120	150	554	216	400	80	70	M20	170	140	22	20
IE2-K11R 315 MY4 Ex e IIC	A660	508	110	590	610	494	680.5	457	120	-	573	216	495	80	70	M20	170	140	22	20
IE2-K11R 315 L4 Ex e IIC	A660	508	110	590	610	494	680.5	508	120	-	624	216	564	80	70	M20	170	140	22	20
IE2-K11R 315 LX4 Ex e IIC	A660	508	110	590	610	494	680.5	508	120	-	624	216	684	80	70	M20	170	140	22	20
IE2-K11R 315 S6 Ex e IIC	A660	508	126	590	550	416	460.5	406	120	150	554	216	320	80	70	M20	170	140	22	20
IE2-K11R 315 M6 Ex e IIC	A660	508	126	590	550	416	460.5	457	120	150	554	216	320	80	70	M20	170	140	22	20
IE2-K11R 315 MX6 Ex e IIC	A660	508	110	590	610	494	680.5	457	120	-	573	216	495	80	70	M20	170	140	22	20
IE2-K11R 315 MY6 Ex e IIC	A660	508	110	590	610	494	680.5	457	120	-	573	216	495	80	70	M20	170	140	22	20
IE2-K11R 315 L6 Ex e IIC	A660	508	110	590	610	494	680.5	508	120	-	624	216	564	80	70	M20	170	140	22	20
IE2-K11R 315 LX6 Ex e IIC	A660	508	110	590	610	494	680.5	508	120	-	624	216	684	80	70	M20	170	140	22	20
IE2-K11R 315 S8 Ex e IIC	A660	508	126	590	550	416	460.5	406	120	150	554	216	320	80	70	M20	170	140	22	20
IE2-K11R 315 M8 Ex e IIC	A660	508	126	590	550	416	460.5	457	120	150	554	216	320	80	70	M20	170	140	22	20
IE2-K11R 315 MX8 Ex e IIC	A660	508	110	590	610	494	680.5	457	120	-	573	216	495	80	70	M20	170	140	22	20
IE2-K11R 315 MY8 Ex e IIC	A660	508	110	590	610	494	680.5	457	120	-	573	216	495	80	70	M20	170	140	22	20
IE2-K11R 315 L8 Ex e IIC	A660	508	110	590	610	494	680.5	508	120	-	624	216	564	80	70	M20	170	140	22	20
IE2-K11R 315 LX8 Ex e IIC	A660	508	110	590	610	494	680.5	508	120	-	624	216	684	80	70	M20	170	140	22	20
IE2-K12R 355 MY4 Ex e IIC	A800	610	130	700	715	736	736	560	140	200	750	254	561	100	80	M24	210	170	28	22
IE2-K12R 355 M4 Ex e IIC	A800	610	130	700	715	736	736	560	140	200	750	254	561	100	80	M24	210	170	28	22
IE2-K12R 355 MY6 Ex e IIC	A800	610	130	700	715	736	736	560	140	200	750	254	561	100	80	M24	210	170	28	22
IE2-K12R 355 M6 Ex e IIC	A800	610	130	700	715	736	736	560	140	200	750	254	561	100	80	M24	210	170	28	22
IE2-K12R 355 MX6 Ex e IIC	A800	610	130	700	715	736	736	560	140	200	750	254	681	100	80	M24	210	170	28	22
IE2-K12R 355 MY4 Ex e IIC	A800	610	130	700	715	729	729	560	140	200	750	254	681	100	80	M24	210	170	28	22
IE2-K12R 355 L4 Ex e IIC	A800	610	130	700	715	729	729	630	140	200	750	254	611	100	80	M24	210	170	28	22
IE2-K12R 355 L8 Ex e IIC	A800	610	130	700	715	729	729	630	140	200	750	254	611	100	80	M24	210	170	28	22

¹⁾ Centre holes to DIN 332-DS ...

Three-phase motors with squirrel-cage rotor, High Efficiency IE2

Type of explosion protection – Increased safety „e“ („eb“) for operation in Zone 1 according to EN 60079-7 (VIK Recommendation 1, Three-Phase Asynchronous Motors – Technical Requirements 03.2011)

with surface cooling, type of cooling IC 411
Size 315 to 355

Type of construction IM B35 [IM 2001]

Flange dimensions, see page 10/6

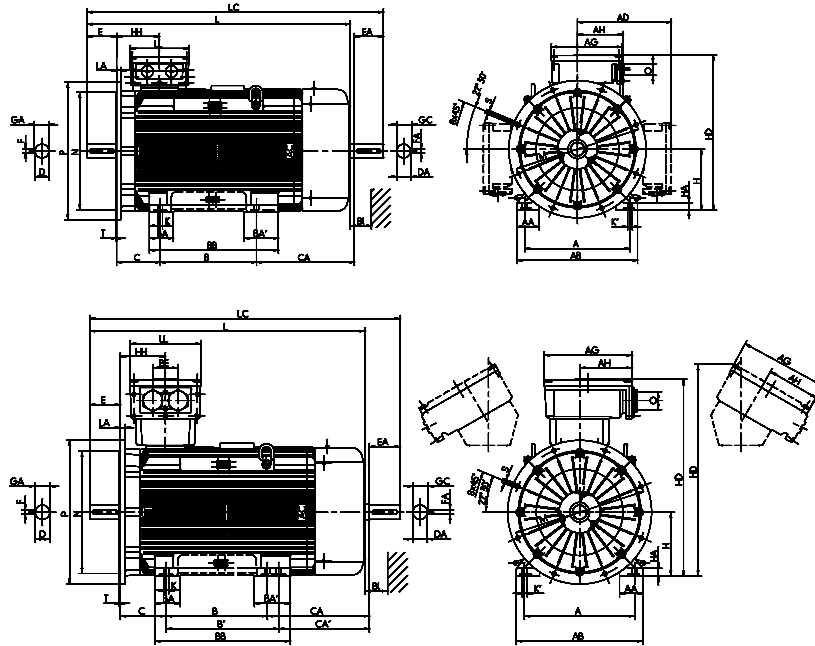

Type designation	GA	GC	H	HA	HD	HD ^{*)}	HD	HH	K	K'	L	LC	TB Type	AG	LL	AH	TB Type	AG	LL	AH	O	LB	BI
	t	t1	h	c	p	p	p	A	s	s'	k	k1	Ex e IIC Standard	x	z	-	Ex e IIC VIK	x	z	-	-	-	BI
IE2-K11R 315 S2 Ex e IIC	69	69	315	44	731	610	775.5	211	28	35	1050	1218	200 A	290	252	-	400 A-SB	415	340	265	M63 x 1.5	8L	55
IE2-K11R 315 M2 Ex e IIC	69	69	315	44	731	610	775.5	211	28	35	1105	1273	200 A	290	252	-	400 A-SB	415	340	265	M63 x 1.5	8L	55
IE2-K11R 315 MX2 Ex e IIC	69	69	315	44	731	610	775.5	211	28	35	1185	1353	200 A	290	252	-	400 A-SB	415	340	265	M63 x 1.5	8L	55
IE2-K11R 315 MY2 Ex e IIC	69	69	315	44	809	628	995.5	230	28	35	1270	1448	630 A	496	390	301	630 A	496	390	301	M63 x 1.5	8L	55
IE2-K11R 315 L2 Ex e IIC	69	69	315	44	809	628	995.5	230	28	35	1390	1568	630 A	496	390	301	630 A	496	390	301	M63 x 1.5	8L	55
IE2-K11R 315 LX2 Ex e IIC	69	69	315	44	809	628	995.5	230	28	35	1510	1688	630 A	496	390	301	630 A	496	390	301	M63 x 1.5	8L	55
IE2-K11R 315 S4 Ex e IIC	85	74.5	315	44	731	610	775.5	211	28	35	1135	1303	200 A	290	252	-	400 A-SB	415	340	265	M63 x 1.5	8L	55
IE2-K11R 315 M4 Ex e IIC	85	74.5	315	44	731	610	775.5	211	28	35	1135	1303	200 A	290	252	-	400 A-SB	415	340	265	M63 x 1.5	8L	55
IE2-K11R 315 MX4 Ex e IIC	85	74.5	315	44	731	610	775.5	211	28	35	1210	1383	200 A	290	252	-	400 A-SB	415	340	265	M63 x 1.5	8L	55
IE2-K11R 315 MY4 Ex e IIC	85	74.5	315	44	809	628	995.5	230	28	35	1300	1478	630 A	496	390	301	630 A	496	390	301	M63 x 1.5	8L	55
IE2-K11R 315 L4 Ex e IIC	85	74.5	315	44	809	628	995.5	230	28	35	1420	1598	630 A	496	390	301	630 A	496	390	301	M63 x 1.5	8L	55
IE2-K11R 315 LX4 Ex e IIC	85	74.5	315	44	809	628	995.5	230	28	35	1540	1718	630 A	496	390	301	630 A	496	390	301	M63 x 1.5	8L	55
IE2-K11R 315 S6 Ex e IIC	85	74.5	315	44	731	610	775.5	211	28	35	1135	1303	200 A	290	252	-	400 A-SB	415	340	265	M63 x 1.5	8L	55
IE2-K11R 315 M6 Ex e IIC	85	74.5	315	44	731	610	775.5	211	28	35	1135	1303	200 A	290	252	-	400 A-SB	415	340	265	M63 x 1.5	8L	55
IE2-K11R 315 MX6 Ex e IIC	85	74.5	315	44	809	628	995.5	230	28	35	1300	1478	630 A	496	390	301	630 A	496	390	301	M63 x 1.5	8L	55
IE2-K11R 315 MY6 Ex e IIC	85	74.5	315	44	809	628	995.5	230	28	35	1300	1478	630 A	496	390	301	630 A	496	390	301	M63 x 1.5	8L	55
IE2-K11R 315 L6 Ex e IIC	85	74.5	315	44	809	628	995.5	230	28	35	1420	1598	630 A	496	390	301	630 A	496	390	301	M63 x 1.5	8L	55
IE2-K11R 315 LX6 Ex e IIC	85	74.5	315	44	809	628	995.5	230	28	35	1420	1598	630 A	496	390	301	630 A	496	390	301	M63 x 1.5	8L	55
IE2-K11R 315 S8 Ex e IIC	85	74.5	315	44	731	610	775.5	211	28	35	1135	1303	200 A	290	252	-	400 A-SB	415	340	265	M63 x 1.5	8L	55
IE2-K11R 315 M8 Ex e IIC	85	74.5	315	44	731	610	775.5	211	28	35	1135	1303	200 A	290	252	-	400 A-SB	415	340	265	M63 x 1.5	8L	55
IE2-K11R 315 MX8 Ex e IIC	85	74.5	315	44	809	628	995.5	230	28	35	1300	1478	630 A	496	390	301	630 A	496	390	301	M63 x 1.5	8L	55
IE2-K11R 315 MY8 Ex e IIC	85	74.5	315	44	809	628	995.5	230	28	35	1300	1478	630 A	496	390	301	630 A	496	390	301	M63 x 1.5	8L	55
IE2-K11R 315 L8 Ex e IIC	85	74.5	315	44	809	628	995.5	230	28	35	1420	1598	630 A	496	390	301	630 A	496	390	301	M63 x 1.5	8L	55
IE2-K11R 315 LX8 Ex e IIC	85	74.5	315	44	809	628	995.5	230	28	35	1420	1598	630 A	496	390	301	630 A	496	390	301	M63 x 1.5	8L	55
IE2-K12R 355 MY4 Ex e IIC	106	85	355	44	1091	1172	736	250	28	35	1570	1755	630 A	496	390	301	630 A	496	390	301	M75 x 1.5	8L	60
IE2-K12R 355 M4 Ex e IIC	106	85	355	44	1091	1172	736	250	28	35	1570	1755	630 A	496	390	301	630 A	496	390	301	M75 x 1.5	8L	60
IE2-K12R 355 MY6 Ex e IIC	106	85	355	44	1091	1172	736	250	28	35	1570	1755	630 A	496	390	301	630 A	496	390	301	M75 x 1.5	8L	60
IE2-K12R 355 M6 Ex e IIC	106	85	355	44	1091	1172	736	250	28	35	1570	1755	630 A	496	390	301	630 A	496	390	301	M75 x 1.5	8L	60
IE2-K12R 355 MX6 Ex e IIC	106	85	355	44	1091	1172	736	250	28	35	1690	1875	630 A	496	390	301	630 A	496	390	301	M75 x 1.5	8L	60
IE2-K12R 355 MY8 Ex e IIC	106	85	355	44	1084	1174	729	327	28	35	1690	1875	1000 A	615	474	385	1000 A	615	474	385	M75 x 1.5	8L	60
IE2-K12R 355 L4 Ex e IIC	106	85	355	44	1084	1174	729	327	28	35	1690	1875	1000 A	615	474	385	1000 A	615	474	385	M75 x 1.5	8L	60
IE2-K12R 355 L8 Ex e IIC	106	85	355	44	1084	1174	729	327	28	35	1690	1875	1000 A	615	474	385	1000 A	615	474	385	M75 x 1.5	8L	60

^{*)} Terminal box left/right

Three-phase motors with squirrel-cage rotor, High Efficiency IE2

Type of explosion protection – Increased safety „e“ („eb“) for operation in Zone 1 according to EN 60079-7 (VIK Recommendation 1, Three-Phase Asynchronous Motors – Technical Requirements 03.2011)

Low-noise design with direction-dependent fan

with surface cooling, type of cooling IC 411
Size 315 to 355

Type of construction IM B3 [IM 1001]

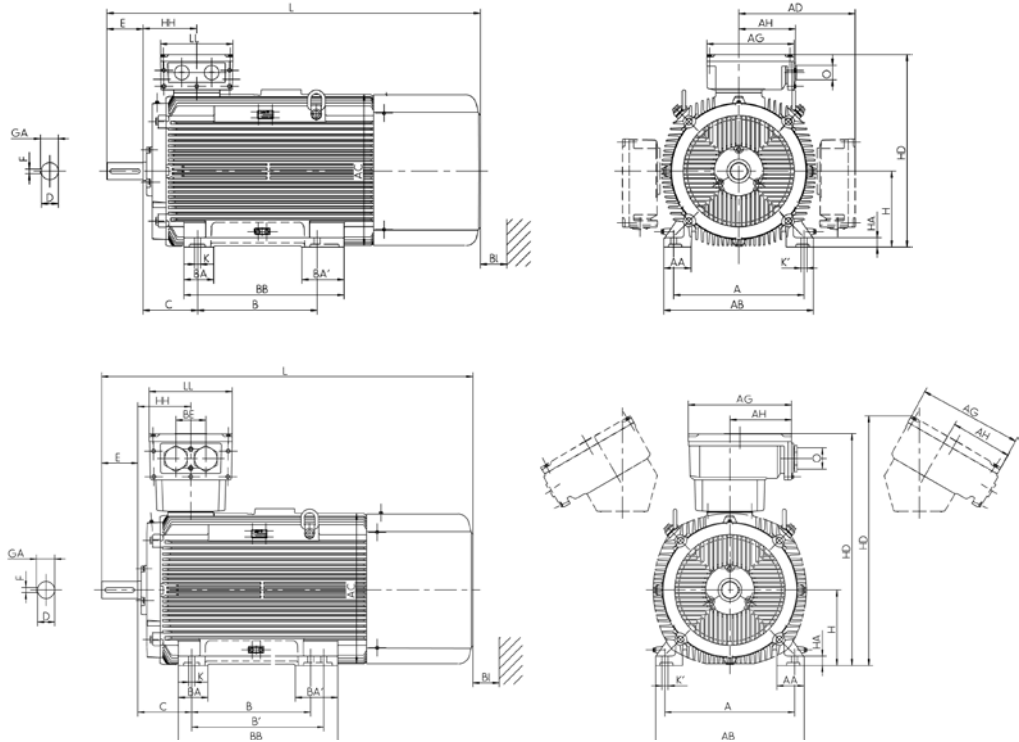

Type designation	Flange size	A	AA	AB	AC	AD	AD	B	BA	BA'	BB	C	CA	D	DB ¹⁾	E	F
		b	n	f	g	g1	g1	a	m	m1	e	w1	w2	d	l	u	
IE2-K11R 315 S2G Ex e IIC	A660	508	126	590	550	416	460.5	406	120	-	503	216	-	65	M20	140	18
IE2-K11R 315 M2G Ex e IIC	A660	508	126	590	550	416	460.5	457	120	150	554	216	-	65	M20	140	18
IE2-K11R 315 MX2G Ex e IIC	A660	508	126	590	550	416	460.5	457	120	150	554	216	-	65	M20	140	18
IE2-K11R 315 MY2G Ex e IIC	A660	508	110	590	610	494	680.5	457	120	-	573	216	495	65	M20	140	18
IE2-K11R 315 L2G Ex e IIC	A660	508	110	590	610	494	680.5	508	120	-	624	216	564	65	M20	140	18
IE2-K11R 315 LX2G Ex e IIC	A660	508	110	590	610	494	680.5	508	120	-	624	216	684	65	M20	140	18
IE2-K12R 355 MY2G Ex e IIC	A800	610	130	700	715	736	736	560	140	200	750	254	561	80	M20	170	22
IE2-K12R 355 M2G Ex e IIC	A800	610	130	700	715	736	736	560	140	200	750	254	561	80	M20	170	22
IE2-K12R 355 MX2G Ex e IIC	A800	610	130	700	715	729	729	560	140	200	750	254	681	80	M20	170	22
IE2-K12R 355 L2G Ex e IIC	A800	610	130	700	715	729	729	630	140	200	750	254	611	80	M20	170	22

¹⁾ Centre holes to DIN 332-DS ...

Three-phase motors with squirrel-cage rotor, High Efficiency IE2

Type of explosion protection – Increased safety „e“ („eb“) for operation in Zone 1 according to EN 60079-7 (VIK Recommendation 1, Three-Phase Asynchronous Motors – Technical Requirements 03.2011)

Low-noise design with direction-dependent fan

with surface cooling, type of cooling IC 411
Size 315 to 355

Type of construction IM B35 [IM 2001]

Flange dimensions, see page 10/6

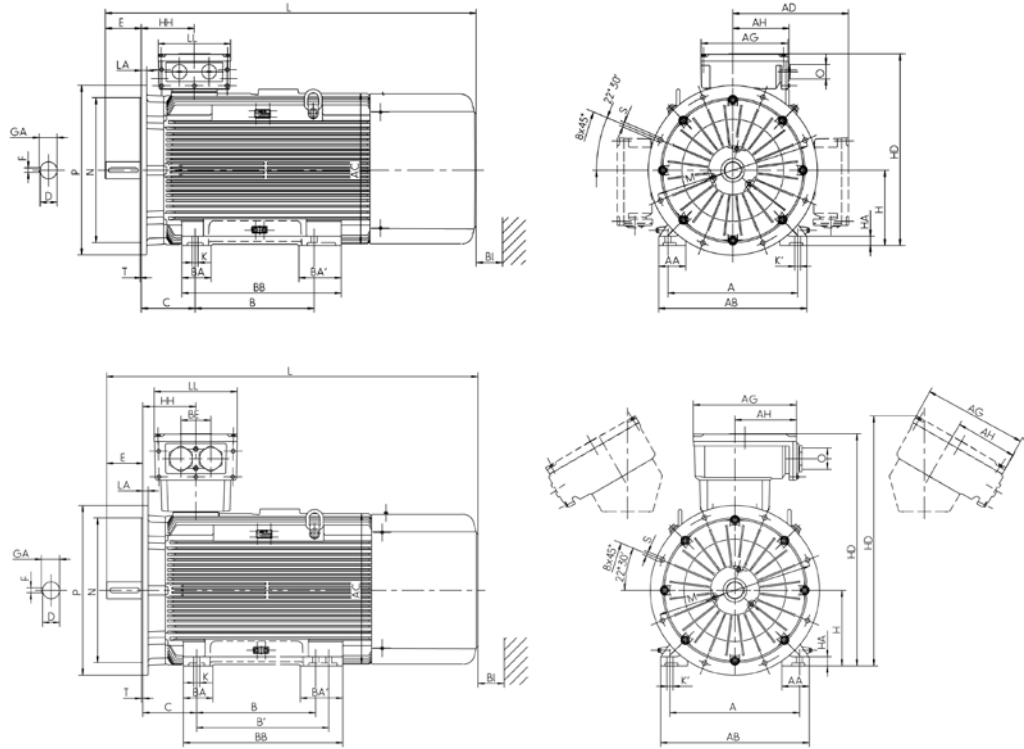

Type designation	GA	H	HA	HD	HD ^{*)}	HD	HH	K	K'	L	TB Type	AG	LL	AH	TB Type	AG	LL	AH	O	LB	BI
	t	h	c	p	p	p	A	s	s'	k	Ex e IIC Standard	x	z	-	Ex e IIC VIK	x	z	-	-	-	BI
IE2-K11R 315 S2G Ex e IIC	69	315	44	731	610	775.5	211	28	35	1135	200 A	290	252	-	400 A-SB	415	340	265	M63 x 1.5	8L	55
IE2-K11R 315 M2G Ex e IIC	69	315	44	731	610	775.5	211	28	35	1190	200 A	290	252	-	400 A-SB	415	340	265	M63 x 1.5	8L	55
IE2-K11R 315 MX2G Ex e IIC	69	315	44	731	610	775.5	211	28	35	1270	200 A	290	252	-	400 A-SB	415	340	265	M63 x 1.5	8L	55
IE2-K11R 315 MY2G Ex e IIC	69	315	44	809	628	995.5	230	28	35	1270	630 A	496	390	301	630 A	496	390	301	M63 x 1.5	8L	55
IE2-K11R 315 L2G Ex e IIC	69	315	44	809	628	995.5	230	28	35	1510	630 A	496	390	301	630 A	496	390	301	M63 x 1.5	8L	55
IE2-K11R 315 LX2G Ex e IIC	69	315	44	809	628	995.5	230	28	35	1630	630 A	496	390	301	630 A	496	390	301	M63 x 1.5	8L	55
IE2-K12R 355 MY2G Ex e IIC	85	355	44	1091	1172	736	250	28	35	1530	630 A	496	390	301	630 A	496	390	301	M75 x 1.5	8L	60
IE2-K12R 355 M2G Ex e IIC	85	355	44	1091	1172	736	250	28	35	1530	630 A	496	390	301	630 A	496	390	301	M75 x 1.5	8L	60
IE2-K12R 355 MX2G Ex e IIC	85	355	44	1084	1174	729	327	28	35	1650	1000 A	615	474	385	1000 A	615	474	385	M75 x 1.5	8L	60
IE2-K12R 355 L2G Ex e IIC	85	355	44	1084	1174	729	327	28	35	1650	1000 A	615	474	385	1000 A	615	474	385	M75 x 1.5	8L	60

^{*)} Terminal box left/right

Three-phase motors with squirrel-cage rotor, High Efficiency IE2

Type of explosion protection – Increased safety „e“ („eb“) for operation in Zone 1 according to EN 60079-7 (VIK Recommendation 1, Three-Phase Asynchronous Motors – Technical Requirements 03.2011)

with surface cooling, type of cooling IC 411

Type of construction IM B14 [IM 3601]

Flange dimensions, see page 10/6

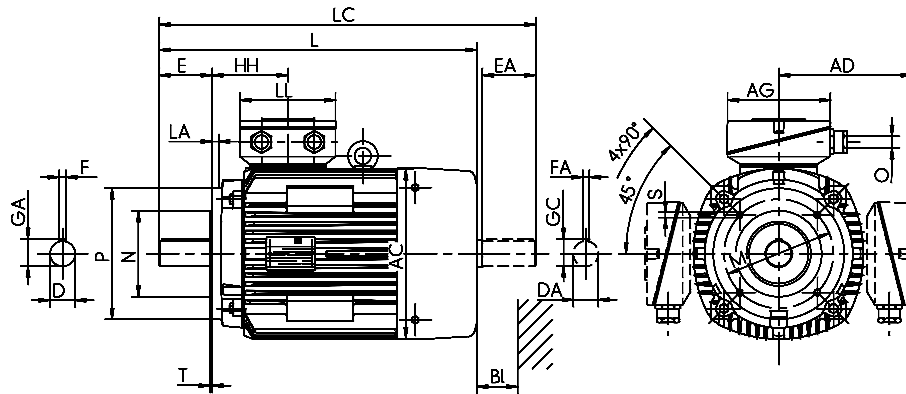

Type designation	Flange size		A	AA	AB	AC	AD	AD	B	BA	BB	C	CA	D	DA	DB ¹⁾	E	EA	F	FA
	B14K, B34K	B14G, B34G																		
			b	n	f	g	g1	g1	a	m	e	w1	w2	d	d1		l	l1	u	u1
IE2-KPR 80 K2 Ex e IIC	C120	C160	125	26	152	157	138	138	100	-	124	50	80	19	19	M6	40	40	6	6
IE2-KPR 80 G2, 4 Ex e IIC	C120	C160	125	26	152	157	138	138	100	-	146	50	102	19	19	M6	40	40	6	6
IE2-KPR 90 S2, 4, 6 Ex e IIC	C140	C160	140	40	178	177	146	146	100	-	130	56	120	24	24	M8	50	50	8	8
IE2-KPR 90 L2 Ex e IIC	C140	C160	140	40	178	177	146	146	125	-	155	56	95	24	24	M8	50	50	8	8
IE2-KPR 90 L4, 6 Ex e IIC	C140	C160	140	40	178	177	146	146	125	-	155	56	125	24	24	M8	50	50	8	8
IE2-KPR 100 L2, S8	C160	C200	160	42	193	196	155	155	140	-	175	63	102	28	28	M10	60	60	8	8
IE2-KPR 100 L4 Ex e IIC	C160	C200	160	42	193	196	155	155	140	-	175	63	136	28	28	M10	60	60	8	8
IE2-KPR 100 L4 Ex e IIC	C160	C200	160	42	193	196	155	155	140	-	175	63	166	28	28	M10	60	60	8	8
IE2-KPR 100 LX6 Ex e IIC	C160	C200	160	42	193	196	155	155	140	-	175	63	136	28	28	M10	60	60	8	8
IE2-KPER 112 MX2 Ex e IIC	C160	C200	190	52	225	196	155	155	140	-	180	70	129	28	28	M10	60	60	8	8
IE2-KPER 112 MZ4 Ex e IIC	C160	C200	190	52	225	196	155	155	140	-	180	70	199	28	28	M10	60	60	8	8
IE2-KPER112 MV6 Ex e IIC	C160	C200	190	52	225	196	155	155	140	-	180	70	159	28	28	M10	60	60	8	8
IE2-K11R 112 M2 Ex e IIC	C160	C200	190	45	226	217	220	220	140	42	172	70	192	28	28	M10	60	60	8	8
IE2-K11R 112 M4 Ex e IIC	C160	C200	190	45	226	217	220	220	140	42	172	70	192	28	28	M10	60	60	8	8
IE2-K11R 112 M6 Ex e IIC	C160	C200	190	45	226	217	220	220	140	42	172	70	192	28	28	M10	60	60	8	8
IE2-K11R 132 S2 Ex e IIC	C160	C200	216	50	256	217	220	220	140	53	180	89	173	38	32	M12	80	80	10	10
IE2-K11R 132 SX2 Ex e IIC	C200	C250	216	50	256	258	246	246	140	53	180	89	176	38	32	M12	80	80	10	10
IE2-K11R 132 S4 Ex e IIC	C200	C250	216	50	256	258	246	246	140	53	180	89	176	38	32	M12	80	80	10	10
IE2-K11R 132 S6 Ex e IIC	C160	C200	216	50	256	217	220	220	140	53	180	89	173	38	32	M12	80	80	10	10
IE2-K11R 132 M4 Ex e IIC	C200	C250	216	50	256	258	246	246	178	53	218	89	186	38	38	M12	80	80	10	10
IE2-K11R 132 M6 Ex e IIC	C160	C200	216	50	256	217	220	220	178	53	218	89	135	38	32	M12	80	80	10	10
IE2-K11R 132 MX6 Ex e IIC	C200	C250	216	50	256	258	246	246	178	53	218	89	186	38	38	M12	80	80	10	10
IE2-K11R 160 M2 Ex e IIC	C250	C300	254	55	296	313	249	275	210	60	257	108	148	42	38	M16	110	110	12	10
IE2-K11R 160 M4 Ex e IIC	C250	C300	254	55	296	313	249	275	210	60	257	108	148	42	38	M16	110	110	12	10
IE2-K11R 160 M8 Ex e IIC	C250	C300	254	55	296	258	256	256	210	60	257	108	185	42	38	M16	110	80	12	10
IE2-K11R 160 M6 Ex e IIC	C200	C250	254	55	296	258	256	256	210	60	257	108	185	42	38	M16	110	80	12	10
IE2-K11R 160 MX2 Ex e IIC	C250	C300	254	55	296	313	249	275	210	56	257	108	186	42	42	M16	110	110	12	12
IE2-K11R 160 L2 Ex e IIC	C250	C300	254	55	296	313	249	275	254	60	301	108	142	42	42	M16	110	110	12	12
IE2-K11R 160 L4 Ex e IIC	C250	C300	254	55	296	313	249	275	254	60	301	108	200	42	42	M16	110	110	12	12
IE2-K11R 160 L6 Ex e IIC	C250	C300	254	55	296	313	249	275	254	60	301	108	142	42	42	M16	110	110	12	12

¹⁾ Centre holes to DIN 332-DS ...

Three-phase motors with squirrel-cage rotor, High Efficiency IE2

Type of explosion protection – Increased safety „e“ („eb“) for operation in Zone 1 according to EN 60079-7 (VIK Recommendation 1, Three-Phase Asynchronous Motors – Technical Requirements 03.2011)

with surface cooling, type of cooling IC 411

Type of construction IM B34 [IM 2101]

Flange dimensions, see page 10/6

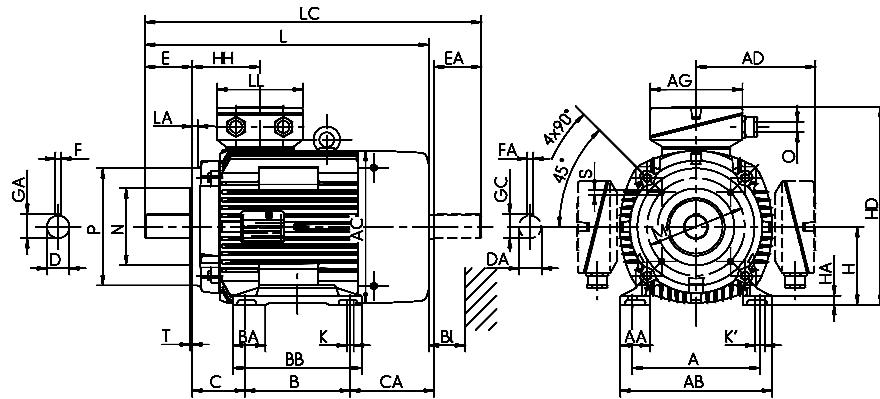

Type designation	GA	GC	H	HA	HD	HD ^{*)}	HD	HH	K	K'	L	LC	TB Type	AG	LL	TB Type	AG	LL	O	LB	BI
IE2-KPR 80 K2 Ex e IIC	21.5	21.5	80	9	218	***)	218	79	10	10	267	310	KA 05 - 13	104	112	KA 05 - 13	104	112	M20 x 1.5	4L	16
IE2-KPR 80 G2, 4 Ex e IIC	21.5	21.5	80	9	218	***)	218	79	10	10	289	332	KA 05 - 13	104	112	KA 05 - 13	104	112	M20 x 1.5	4L	16
IE2-KPR 90 S2, 4, 6 Ex e IIC	27	27	90	10.5	236	***)	236	84	10	10	323	376	KA 05 - 13	104	112	KA 05 - 13	104	112	M25 x 1.5	4L	18
IE2-KPR 90 L2 Ex e IIC	27	27	90	10.5	236	***)	236	84	10	10	323	376	KA 05 - 13	104	112	KA 05 - 13	104	112	M25 x 1.5	4L	18
IE2-KPR 90 L4, 6 Ex e IIC	27	27	90	10.5	236	***)	236	84	10	10	353	406	KA 05 - 13	104	112	KA 05 - 13	104	112	M25 x 1.5	4L	18
IE2-KPR 100 L2, S8	31	31	100	13	255	***)	255	86	12	12	359	425	KA 05 - 13	104	112	KA 05 - 13	104	112	M25 x 1.5	4L	20
IE2-KPR 100 L4 Ex e IIC	31	31	100	13	255	***)	255	86	12	12	393	459	KA 05 - 13	104	112	KA 05 - 13	104	112	M25 x 1.5	4L	20
IE2-KPR 100 LX4 Ex e IIC	31	31	100	13	255	***)	255	86	12	12	423	489	KA 05 - 13	104	112	KA 05 - 13	104	112	M25 x 1.5	4L	20
IE2-KPR 100 LX6 Ex e IIC	31	31	100	13	255	***)	255	86	12	12	393	459	KA 05 - 13	104	112	KA 05 - 13	104	112	M25 x 1.5	4L	20
IE2-KPER 112 MX2 Ex e IIC	31	31	112	18	267	***)	267	86	12	12	393	459	KA 05 - 13	104	112	KA 05 - 13	104	112	M25 x 1.5	4L	20
IE2-KPER 112 MZ4 Ex e IIC	31	31	112	18	267	***)	267	86	12	12	463	529	KA 05 - 13	104	112	KA 05 - 13	104	112	M25 x 1.5	4L	20
IE2-KPER112 MV6 Ex e IIC	31	31	112	18	267	***)	267	86	12	12	423	489	KA 05 - 13	104	112	KA 05 - 13	104	112	M25 x 1.5	4L	20
IE2-K11R 112 M2 Ex e IIC	31	31	112	15	333	236.5	333	108	12	12	459	522	25 A	143	134	25 AV	143	134	M32 x 1.5	4L	35
IE2-K11R 112 M4 Ex e IIC	31	31	112	15	333	236.5	333	108	12	12	459	522	25 A	143	134	25 AV	143	134	M32 x 1.5	4L	35
IE2-K11R 112 M6 Ex e IIC	31	31	112	15	333	236.5	333	108	12	12	459	522	25 A	143	134	25 AV	143	134	M32 x 1.5	4L	35
IE2-K11R 132 S2 Ex e IIC	41	35	132	16	353	256.5	353	108	12	12	479	562	25 A	143	134	25 AV	143	134	M32 x 1.5	4L	35
IE2-K11R 132 SX2 Ex e IIC	41	35	132	15	374	279	374	114	12	12	481	565	25 A	143	134	25 AV	143	134	M32 x 1.5	4L	35
IE2-K11R 132 S4 Ex e IIC	41	35	132	15	374	279	374	114	12	12	481	565	25 A	143	134	25 AV	143	134	M32 x 1.5	4L	35
IE2-K11R 132 S6 Ex e IIC	41	35	132	16	353	256.5	353	108	12	12	479	562	25 A	143	134	25 AV	143	134	M32 x 1.5	4L	35
IE2-K11R 132 M4 Ex e IIC	41	41	132	15	374	279	374	114	12	12	529	613	25 A	143	134	25 AV	143	134	M32 x 1.5	4L	35
IE2-K11R 132 M6 Ex e IIC	41	35	132	16	353	256.5	353	108	12	12	529	612	25 A	143	134	25 AV	143	134	M32 x 1.5	4L	35
IE2-K11R 132 MX6 Ex e IIC	41	41	132	15	374	279	374	114	12	12	529	613	25 A	143	134	25 AV	143	134	M32 x 1.5	4L	35
IE2-K11R 160 M2 Ex e IIC	45	41	160	18	409	336	435	138	15	20	571	686	63 A	184	172	100/63 AV	223	214	M40 x 1.5	4L	35
IE2-K11R 160 M4 Ex e IIC	45	41	160	18	409	336	435	138	15	20	571	686	63 A	184	172	100/63 AV	223	214	M40 x 1.5	4L	35
IE2-K11R 160 M8 Ex e IIC	45	41	160	18	417	307	417	114	15	15	609	693	25 A	143	134	25 AV	143	134	M32 x 1.5	4L	35
IE2-K11R 160 M6 Ex e IIC	45	41	160	18	417	307	417	114	15	15	609	693	25 A	143	134	25 AV	143	134	M32 x 1.5	4L	35
IE2-K11R 160 MX2 Ex e IIC	45	45	160	18	409	336	435	138	15	20	609	724	63 A	184	172	100/63 AV	223	214	M40 x 1.5	4L	35
IE2-K11R 160 L2 Ex e IIC	45	45	160	18	409	336	435	138	15	20	609	724	63 A	184	172	100/63 AV	223	214	M40 x 1.5	4L	35
IE2-K11R 160 L4 Ex e IIC	45	45	160	18	409	336	435	138	15	20	667	783	63 A	184	172	100/63 AV	223	214	M40 x 1.5	4L	35
IE2-K11R 160 L6 Ex e IIC	45	45	160	18	409	336	435	138	15	20	609	724	63 A	184	172	100/63 AV	223	214	M40 x 1.5	4L	35

**) Terminal box left/right

**) upon request

Three-phase motors with squirrel-cage rotor, High Efficiency IE2

Type of explosion protection – Increased safety „e“ („eb“) for operation in Zone 1 according to EN 60079-7 (VIK Recommendation 1, Three-Phase Asynchronous Motors – Technical Requirements 03.2011)

Low-noise design with direction-dependent fan

with surface cooling, type of cooling IC 411

Type of construction IM B14 [IM 3601]

Flange dimensions, see page 10/6

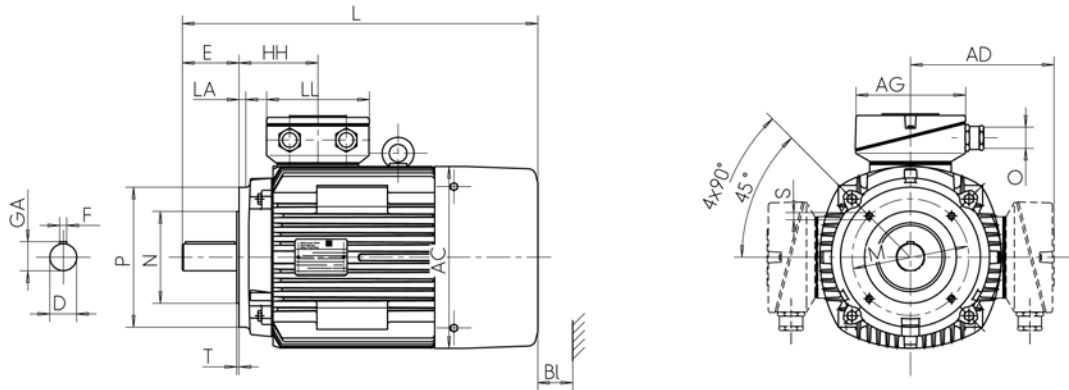

Type designation	Flange size		A	AA	AB	AC	AD	AD	B	BA	BB	C	D	DB ¹	E	F
	B14K, B34K	B14G, B34G	b	n	f	g	g1	g1	a	m	e	w1	d		l	u
IE2-K11R 132 S2G Ex e IIC	C160	C200	216	50	256	217	220	220	140	53	180	89	38	M12	80	10
IE2-K11R 132 SX2G Ex e IIC	C200	C250	216	50	256	258	246	246	140	53	180	89	38	M12	80	10
IE2-K11R 160 MG2 Ex e IIC	C250	C300	254	55	296	313	249	275	210	60	257	108	42	M16	110	12
IE2-K11R 160 MX2G Ex e IIC	C250	C300	254	55	296	313	249	275	210	56	257	108	42	M16	110	12
IE2-K11R 160 L2G Ex e IIC	C250	C300	254	55	296	313	249	275	254	60	301	108	42	M16	110	12

¹ Centre holes to DIN 332-DS ...

Three-phase motors with squirrel-cage rotor, High Efficiency IE2

Type of explosion protection – Increased safety „e“ („eb“) for operation in Zone 1 according to EN 60079-7 (VIK Recommendation 1, Three-Phase Asynchronous Motors – Technical Requirements 03.2011)

Low-noise design with direction-dependent fan

with surface cooling, type of cooling IC 411

Type of construction IM B34 [IM 2101]

Flange dimensions, see page 10/6

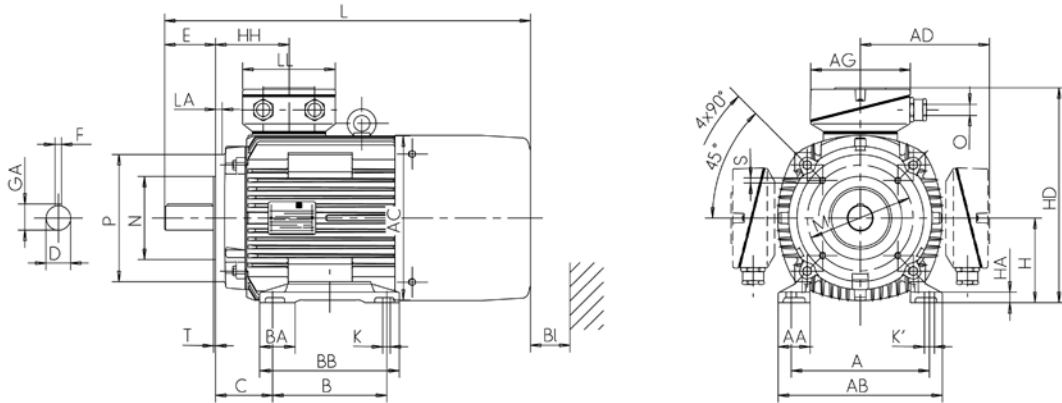

Type designation	GA	H	HA	HD	HD ^{**}	HD	HH	K	K'	L	TB Type Ex e IIC Standard	AG	LL	TB Type Ex e IIC VIK	AG	LL	O	LB	BI
	t	h	c	p	p	p	A	s	s'	k		x	z		x	z	-		BI
IE2-K11R 132 S2G Ex e IIC	41	132	16	353	256.5	353	108	12	12	583	25 A	143	134	25 AV	143	134	M32 x 1.5	4L	35
IE2-K11R 132 SX2G Ex e IIC	41	132	15	374	279	374	114	12	12	595	25 A	143	134	25 AV	143	134	M32 x 1.5	4L	35
IE2-K11R 160 MG2 Ex e IIC	45	160	18	409	336	435	138	15	20	698	63 A	184	172	100/63 AV	223	214	M40 x 1.5	4L	35
IE2-K11R 160 MX2G Ex e IIC	45	160	18	409	336	435	138	15	20	609	63 A	184	172	100/63 AV	223	214	M40 x 1.5	4L	35
IE2-K11R 160 L2G Ex e IIC	45	160	18	409	336	435	138	15	20	736	63 A	184	172	100/63 AV	223	214	M40 x 1.5	4L	35

** Terminal box left/right

Three-phase motors with squirrel-cage rotor, High Efficiency IE2

Type of explosion protection – Increased safety „e“ („eb“) for operation in Zone 1 according to EN 60079-7 (VIK Recommendation 1, Three-Phase Asynchronous Motors – Technical Requirements 03.2011)

with surface cooling, type of cooling IC 411

Type of construction IM B5 [IM 3001], IM V1 [IM 3011]

Flange dimensions, see page 10/6

Type designation	Flange size	AC	AD	AD	D	DA	DB ¹⁾	E	EA	F	FA	GA	GC	H	HH
		g	g1	VIK g1	d	d1		l	l1	u	u1	t	t1	h	A
IE2-KPR 80 K2 Ex e IIC	A200	157	138	138	19	19	M6	40	40	6	6	21.5	21.5	80	79
IE2-KPR 80 G2, 4 Ex e IIC	A200	157	138	138	19	19	M6	40	40	6	6	21.5	21.5	80	79
IE2-KPR 90 S2, 4, 6 Ex e IIC	A200	177	146	146	24	24	M8	50	50	8	8	27	27	90	123
IE2-KPR 90 L2 Ex e IIC	A200	177	146	146	24	24	M8	50	50	8	8	27	27	90	123
IE2-KPR 90 L4, 6 Ex e IIC	A200	177	146	146	24	24	M8	50	50	8	8	27	27	90	123
IE2-KPR 100 L2, S8	A250	196	155	155	28	28	M10	60	60	8	8	31	31	100	86
IE2-KPR 100 L4 Ex e IIC	A250	196	155	155	28	28	M10	60	60	8	8	31	31	100	86
IE2-KPR 100 LX4 Ex e IIC	A250	196	155	155	28	28	M10	60	60	8	8	31	31	100	86
IE2-KPR 100 LX6 Ex e IIC	A250	196	155	155	28	28	M10	60	60	8	8	31	31	100	86
IE2-KPER 112 MX2 Ex e IIC	A250	196	155	155	28	28	M10	60	60	8	8	31	31	112	86
IE2-KPER 112 MZ4 Ex e IIC	A250	196	155	155	28	28	M10	60	60	8	8	31	31	112	86
IE2-KPER112 MV6 Ex e IIC	A250	196	155	155	28	28	M10	60	60	8	8	31	31	112	86
IE2-K11R 112 M2 Ex e IIC	A250	217	220	220	28	28	M10	60	60	8	8	31	31	112	108
IE2-K11R 112 M4 Ex e IIC	A250	217	220	220	28	28	M10	60	60	8	8	31	31	112	108
IE2-K11R 112 M6 Ex e IIC	A250	217	220	220	28	28	M10	60	60	8	8	31	31	112	108
IE2-K11R 132 S2 Ex e IIC	A300	217	220	220	38	32	M12	80	80	10	10	41	35	132	108
IE2-K11R 132 SX2 Ex e IIC	A300	258	246	246	38	32	M12	80	80	10	10	41	35	132	114
IE2-K11R 132 S4 Ex e IIC	A300	258	246	246	38	32	M12	80	80	10	10	41	35	132	114
IE2-K11R 132 S6 Ex e IIC	A300	217	220	220	38	32	M12	80	80	10	10	41	35	132	108
IE2-K11R 132 M4 Ex e IIC	A300	258	246	246	38	38	M12	80	80	10	10	41	41	132	114
IE2-K11R 132 M6 Ex e IIC	A300	217	220	220	38	32	M12	80	80	10	10	41	35	132	108
IE2-K11R 132 MX6 Ex e IIC	A300	258	246	246	38	38	M12	80	80	10	10	41	41	132	114
IE2-K11R 160 M2 Ex e IIC	A350	313	249	275	42	38	M16	110	110	12	10	45	41	160	138
IE2-K11R 160 M4 Ex e IIC	A350	313	249	275	42	38	M16	110	110	12	10	45	41	160	138
IE2-K11R 160 M8 Ex e IIC	A350	258	256	256	42	38	M16	110	80	12	10	45	41	160	114
IE2-K11R 160 M6 Ex e IIC	A350	258	256	256	42	38	M16	110	80	12	10	45	41	160	114
IE2-K11R 160 MX2 Ex e IIC	A350	313	249	275	42	42	M16	110	110	12	12	45	45	160	138
IE2-K11R 160 L2 Ex e IIC	A350	313	249	275	42	42	M16	110	110	12	12	45	45	160	138
IE2-K11R 160 L4 Ex e IIC	A350	313	249	275	42	42	M16	110	110	12	12	45	45	160	138
IE2-K11R 160 L6 Ex e IIC	A350	313	249	275	42	42	M16	110	110	12	12	45	45	160	138
IE2-K11R 180 M2 Ex e IIC	A350	351	268	294	48	48	M16	110	110	14	14	51.5	51.5	180	147
IE2-K11R 180 M4 Ex e IIC	A350	351	268	294	48	42	M16	110	110	14	12	51.5	45	180	147
IE2-K11R 180 L4 Ex e IIC	A350	351	268	294	48	48	M16	110	110	14	14	51.5	51.5	180	147
IE2-K11R 180 L6 Ex e IIC	A350	351	268	294	48	42	M16	110	110	14	12	51.5	45	180	147
IE2-K11R 200 L2 Ex e IIC	A400	351	268	294	55	48	M20	110	110	16	14	59	51.5	200	147
IE2-K11R 200 LX2 Ex e IIC	A400	390	311	375	55	48	M20	110	110	16	16	59	59	200	168
IE2-K11R 200 L4 Ex e IIC	A400	390	311	375	55	48	M20	110	110	16	14	59	51.5	200	168
IE2-K11R 200 LX6 Ex e IIC	A400	390	311	375	55	48	M20	110	110	16	14	59	51.5	200	168
IE2-K11R 200 L6 Ex e IIC	A400	351	268	294	55	48	M20	110	110	16	14	59	51.5	200	147
IE2-K11R 225 M2 Ex e IIC	A450	440	300	300	55	55	M20	110	110	16	16	59	59	225	177
IE2-K11R 225 S4 Ex e IIC	A450	440	300	300	60	55	M20	140	110	18	16	64	59	225	177
IE2-K11R 225 M4 Ex e IIC	A450	440	300	300	60	55	M20	140	110	18	16	64	59	225	177
IE2-K11R 225 S8 Ex e IIC	A450	390	311	375	60	55	M20	140	110	18	16	64	59	225	168
IE2-K11R 225 M6 Ex e IIC	A450	440	324	406	60	55	M20	140	110	18	16	64	59	225	177
IE2-K11R 225 M8 Ex e IIC	A450	440	324	406	60	55	M20	140	110	18	16	64	59	225	177
IE2-K11R 250 M2 Ex e IIC	A550	490	386	403	60	60	M20	140	140	18	18	64	64	250	206
IE2-K11R 250 M4 Ex e IIC	A550	490	386	403	65	55	M20	140	110	18	16	69	59	250	206
IE2-K11R 250 M6 Ex e IIC	A550	490	386	403	65	55	M20	140	110	18	16	69	59	250	206
IE2-K11R 280 S2 Ex e IIC	A550	490	386	403	65	60	M20	140	140	18	18	69	64	280	206
IE2-K11R 280 M2 Ex e IIC	A550	490	386	403	65	65	M20	140	140	18	18	69	69	280	206
IE2-K11R 280 S4 Ex e IIC	A550	550	386	403	75	65	M20	140	140	20	18	79.5	69	280	211
IE2-K11R 280 M4 Ex e IIC	A550	550	386	403	75	65	M20	140	140	20	18	79.5	69	280	211
IE2-K11R 280 S6 Ex e IIC	A550	490	386	403	75	65	M20	140	140	20	18	79.5	69	280	206
IE2-K11R 280 M6 Ex e IIC	A550	550	416	433	75	65	M20	140	140	20	18	79.5	69	280	211
IE2-K11R 280 S8 Ex e IIC	A550	490	386	403	75	65	M20	140	140	20	18	79.5	69	280	206
IE2-K11R 280 M8 Ex e IIC	A550	550	416	433	75	65	M20	140	140	20	18	79.5	69	280	211

¹⁾ Centre holes to DIN 332-DS ...

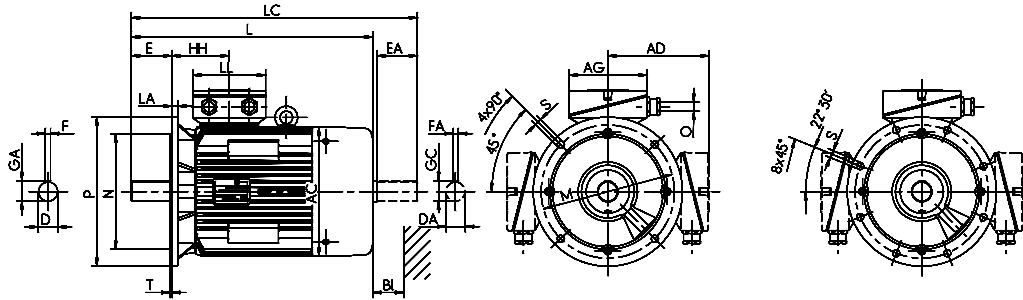

Type designation	L	LC	TB Type Ex e IIC Standard	AG	LL	TB Type Ex e IIC VIK	AG	LL	AH	O	LB	BI
	k	k1		x	z		x	z	-	-		BI
IE2-KPR 80 K2 Ex e IIC	296	310	KA 05 - 13	104	112	KA 05 - 13	104	112	-	M20 x 1.5	4L	16
IE2-KPR 80 G2, 4 Ex e IIC	318	332	KA 05 - 13	104	112	KA 05 - 13	104	112	-	M20 x 1.5	4L	16
IE2-KPR 90 S2, 4, 6 Ex e IIC	390	415	KA 05 - 13	104	112	KA 05 - 13	104	112	-	M25 x 1.5	4L	18
IE2-KPR 90 L2 Ex e IIC	390	415	KA 05 - 13	104	112	KA 05 - 13	104	112	-	M25 x 1.5	4L	18
IE2-KPR 90 L4, 6 Ex e IIC	420	445	KA 05 - 13	104	112	KA 05 - 13	104	112	-	M25 x 1.5	4L	18
IE2-KPR 100 L2, S8	388	425	KA 05 - 13	104	112	KA 05 - 13	104	112	-	M25 x 1.5	4L	20
IE2-KPR 100 L4 Ex e IIC	422	459	KA 05 - 13	104	112	KA 05 - 13	104	112	-	M25 x 1.5	4L	20
IE2-KPR 100 LX4 Ex e IIC	452	489	KA 05 - 13	104	112	KA 05 - 13	104	112	-	M25 x 1.5	4L	20
IE2-KPR 100 LX6 Ex e IIC	422	459	KA 05 - 13	104	112	KA 05 - 13	104	112	-	M25 x 1.5	4L	20
IE2-KPER 112 MX2 Ex e IIC	422	459	KA 05 - 13	104	112	KA 05 - 13	104	112	-	M25 x 1.5	4L	20
IE2-KPER 112 MZ4 Ex e IIC	492	529	KA 05 - 13	104	112	KA 05 - 13	104	112	-	M25 x 1.5	4L	20
IE2-KPER112 MV6 Ex e IIC	452	489	KA 05 - 13	104	112	KA 05 - 13	104	112	-	M25 x 1.5	4L	20
IE2-K11R 112 M2 Ex e IIC	499	522	25 A	143	134	25 AV	143	134	-	M32 x 1.5	4L	35
IE2-K11R 112 M4 Ex e IIC	499	522	25 A	143	134	25 AV	143	134	-	M32 x 1.5	4L	35
IE2-K11R 112 M6 Ex e IIC	499	522	25 A	143	134	25 AV	143	134	-	M32 x 1.5	4L	35
IE2-K11R 132 S2 Ex e IIC	519	562	25 A	143	134	25 AV	143	134	-	M32 x 1.5	4L	35
IE2-K11R 132 SX2 Ex e IIC	521	565	25 A	143	134	25 AV	143	134	-	M32 x 1.5	4L	35
IE2-K11R 132 S4 Ex e IIC	521	565	25 A	143	134	25 AV	143	134	-	M32 x 1.5	4L	35
IE2-K11R 132 S6 Ex e IIC	519	562	25 A	143	134	25 AV	143	134	-	M32 x 1.5	4L	35
IE2-K11R 132 M4 Ex e IIC	569	613	25 A	143	134	25 AV	143	134	-	M32 x 1.5	4L	35
IE2-K11R 132 M6 Ex e IIC	569	612	25 A	143	134	25 AV	143	134	-	M32 x 1.5	4L	35
IE2-K11R 132 MX6 Ex e IIC	569	613	25 A	143	134	25 AV	143	134	-	M32 x 1.5	4L	35
IE2-K11R 160 M2 Ex e IIC	611	686	63 A	184	172	100/63 AV	223	214	-	M40 x 1.5	4L	35
IE2-K11R 160 M4 Ex e IIC	611	686	63 A	184	172	100/63 AV	223	214	-	M40 x 1.5	4L	35
IE2-K11R 160 M8 Ex e IIC	649	693	25 A	143	134	25 AV	143	134	-	M32 x 1.5	4L	35
IE2-K11R 160 M6 Ex e IIC	649	693	25 A	143	134	25 AV	143	134	-	M32 x 1.5	4L	35
IE2-K11R 160 MX2 Ex e IIC	649	724	63 A	184	172	100/63 AV	223	214	-	M40 x 1.5	4L	35
IE2-K11R 160 L2 Ex e IIC	649	724	63 A	184	172	100/63 AV	223	214	-	M40 x 1.5	4L	35
IE2-K11R 160 L4 Ex e IIC	-	783	63 A	184	172	100/63 AV	223	214	-	M40 x 1.5	4L	35
IE2-K11R 160 L6 Ex e IIC	649	724	63 A	184	172	100/63 AV	223	214	-	M40 x 1.5	4L	35
IE2-K11R 180 M2 Ex e IIC	675	751	63 A	184	172	100/63 AV	223	214	-	M40 x 1.5	4L	35
IE2-K11R 180 M4 Ex e IIC	720	796	63 A	184	172	100/63 AV	223	214	-	M40 x 1.5	4L	35
IE2-K11R 180 L4 Ex e IIC	720	796	63 A	184	172	100/63 AV	223	214	-	M40 x 1.5	4L	35
IE2-K11R 180 L6 Ex e IIC	720	796	63 A	184	172	100/63 AV	223	214	-	M40 x 1.5	4L	35
IE2-K11R 200 L2 Ex e IIC	720	796	100/63 AV	223	214	100/63 AV	223	214	-	M50 x 1.5	4L	35
IE2-K11R 200 LX2 Ex e IIC	767	851	100 A	222	214	200 A-SB	335	270	200	M50 x 1.5	4L	35
IE2-K11R 200 L4 Ex e IIC	767	851	100 A	222	214	200 A-SB	335	270	200	M50 x 1.5	4L	35
IE2-K11R 200 LX6 Ex e IIC	767	851	100 A	222	214	200 A-SB	335	270	200	M50 x 1.5	4L	35
IE2-K11R 200 L6 Ex e IIC	720	796	63 A	184	172	100/63 AV	223	214	-	M50 x 1.5	4L	35
IE2-K11R 225 M2 Ex e IIC	872	947	100 A	222	214	200 A-SB	335	270	200	M50 x 1.5	8L	45
IE2-K11R 225 S4 Ex e IIC	797	881	100 A	222	214	200 A-SB	335	270	200	M50 x 1.5	8L	40
IE2-K11R 225 M4 Ex e IIC	947	977	100 A	222	214	200 A-SB	335	270	200	M50 x 1.5	8L	45
IE2-K11R 225 S8 Ex e IIC	802	881	100 A	222	214	200 A-SB	335	270	200	M50 x 1.5	8L	45
IE2-K11R 225 M6 Ex e IIC	947	977	100 A	222	214	200 A-SB	335	270	200	M50 x 1.5	8L	45
IE2-K11R 225 M8 Ex e IIC	947	977	100 A	222	214	200 A-SB	335	270	200	M50 x 1.5	8L	45
IE2-K11R 250 M2 Ex e IIC	1009	1072	200 A	290	252	200 A-SB	335	270	200	M63 x 1.5	8L	55
IE2-K11R 250 M4 Ex e IIC	1009	1042	200 A	290	252	200 A-SB	335	270	200	M63 x 1.5	8L	50
IE2-K11R 250 M6 Ex e IIC	1009	1042	200 A	290	252	200 A-SB	335	270	200	M63 x 1.5	8L	50
IE2-K11R 280 S2 Ex e IIC	1055	1118	200 A	290	252	200 A-SB	335	270	200	M63 x 1.5	8L	55
IE2-K11R 280 M2 Ex e IIC	1055	1118	200 A	290	252	200 A-SB	335	270	200	M63 x 1.5	8L	50
IE2-K11R 280 S4 Ex e IIC	1055	1118	200 A	290	252	200 A-SB	335	270	200	M63 x 1.5	8L	50
IE2-K11R 280 M4 Ex e IIC	1215	1273	200 A	290	252	200 A-SB	335	270	200	M63 x 1.5	8L	55
IE2-K11R 280 S6 Ex e IIC	1055	1118	200 A	290	252	200 A-SB	335	270	200	M63 x 1.5	8L	50
IE2-K11R 280 M6 Ex e IIC	1215	1243	200 A	290	252	200 A-SB	335	270	200	M63 x 1.5	8L	55
IE2-K11R 280 S8 Ex e IIC	1055	1118	200 A	290	252	200 A-SB	335	270	200	M63 x 1.5	8L	50
IE2-K11R 280 M8 Ex e IIC	1215	1243	200 A	290	252	200 A-SB	335	270	200	M63 x 1.5	8L	55

Three-phase motors with squirrel-cage rotor, High Efficiency IE2

Type of explosion protection – Increased safety „e“ („eb“) for operation in Zone 1 according to EN IEC/60079-7 (VIK Recommendation 1, Three-Phase Asynchronous Motors – Technical Requirements 03.2011)

Low-noise design with direction-dependent fan

with surface cooling, type of cooling IC 411

Type of construction IM B5 [IM 3001], IM V1 [IM 3011]

Flange dimensions, see page 10/6

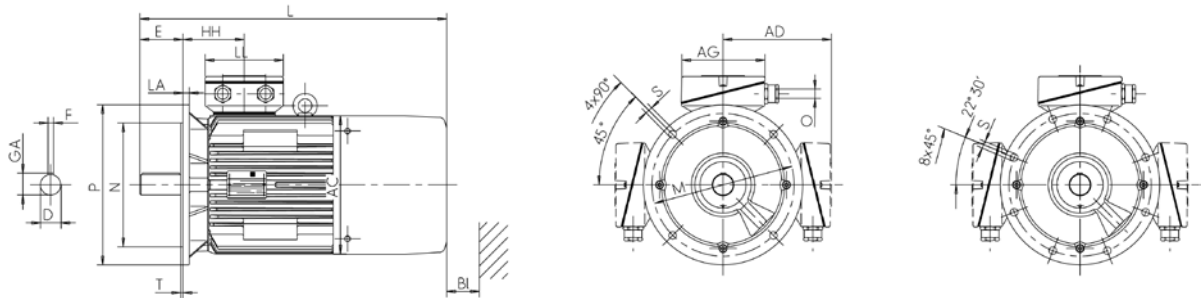

Type designation	Flange size	AC	AD	AD	D	DB ¹⁾	E	F	GA	H	HH
		g	g1	VIK g1	d		l	u	t	h	A
IE2-K11R 132 S2G Ex e IIC	A300	217	220	220	38	M12	80	10	41	132	108
IE2-K11R 132 SX2G Ex e IIC	A300	258	246	246	38	M12	80	10	41	132	114
IE2-K11R 160 M G2 Ex e IIC	A350	313	249	275	42	M16	110	12	45	160	138
IE2-K11R 160 MX2G Ex e IIC	A350	313	249	275	42	M16	110	12	45	160	138
IE2-K11R 160 L2G Ex e IIC	A350	313	249	275	42	M16	110	12	45	160	138
IE2-K11R 180 M2G Ex e IIC	A350	351	268	294	48	M16	110	14	51.5	180	147
IE2-K11R 200 L2G Ex e IIC	A400	351	268	294	55	M20	110	16	59	200	147
IE2-K11R 200 LX2G Ex e IIC	A400	390	311	375	55	M20	110	16	59	200	168
IE2-K11R 225 M2G Ex e IIC	A450	440	300	300	55	M20	110	16	59	225	177
IE2-K11R 250 M2G Ex e IIC	A550	490	386	403	60	M20	140	18	64	250	206
IE2-K11R 280 S2G Ex e IIC	A550	490	386	403	65	M20	140	18	69	280	206
IE2-K11R 280 M2G Ex e IIC	A550	490	386	403	65	M20	140	18	69	280	206

¹⁾ Centre holes to DIN 332-DS ...

Type designation	L	TB Type Ex e IIC Standard	AG	LL	TB Type Ex e IIC VIK	AG	LL	AH	O	LB	BI
	k		x	z		x	z	-	-		BI
IE2-K11R 132 S2G Ex e IIC	623	25 A	143	134	25 AV	143	134	-	M32 x 1.5	4L	35
IE2-K11R 132 SX2G Ex e IIC	635	25 A	143	134	25 AV	143	134	-	M32 x 1.5	4L	35
IE2-K11R 160 M G2 Ex e IIC	738	63 A	184	172	100/63 AV	223	214	-	M40 x 1.5	4L	35
IE2-K11R 160 MX2G Ex e IIC	649	63 A	184	172	100/63 AV	223	214	-	M40 x 1.5	4L	35
IE2-K11R 160 L2G Ex e IIC	776	63 A	184	172	100/63 AV	223	214	-	M40 x 1.5	4L	35
IE2-K11R 180 M2G Ex e IIC	821	63 A	184	172	100/63 AV	223	214	-	M40 x 1.5	4L	35
IE2-K11R 200 L2G Ex e IIC	896	100/63 AV	223	214	100/63 AV	223	214	-	M50 x 1.5	4L	35
IE2-K11R 200 LX2G Ex e IIC	830	100 A	222	214	200 A-SB	335	270	200	M50 x 1.5	4L	35
IE2-K11R 225 M2G Ex e IIC	937	100 A	222	214	200 A-SB	335	270	200	M50 x 1.5	8L	45
IE2-K11R 250 M2G Ex e IIC	1089	200 A	290	252	200 A-SB	335	270	200	M63 x 1.5	8L	55
IE2-K11R 280 S2G Ex e IIC	1089	200 A	290	252	200 A-SB	335	270	200	M63 x 1.5	8L	55
IE2-K11R 280 M2G Ex e IIC	1089	200 A	290	252	200 A-SB	335	270	200	M63 x 1.5	8L	50

Three-phase motors with squirrel-cage rotor, High Efficiency IE2

Type of explosion protection – Increased safety „e“ („eb“) for operation in Zone 1 according to EN 60079-7 (VIK Recommendation 1, Three-Phase Asynchronous Motors – Technical Requirements 03.2011)

with surface cooling, type of cooling IC 411
Size 315, 355

Type of construction IM B5 [IM 3001], IM V1 [IM 3011]

Flange dimensions, see page 10/6

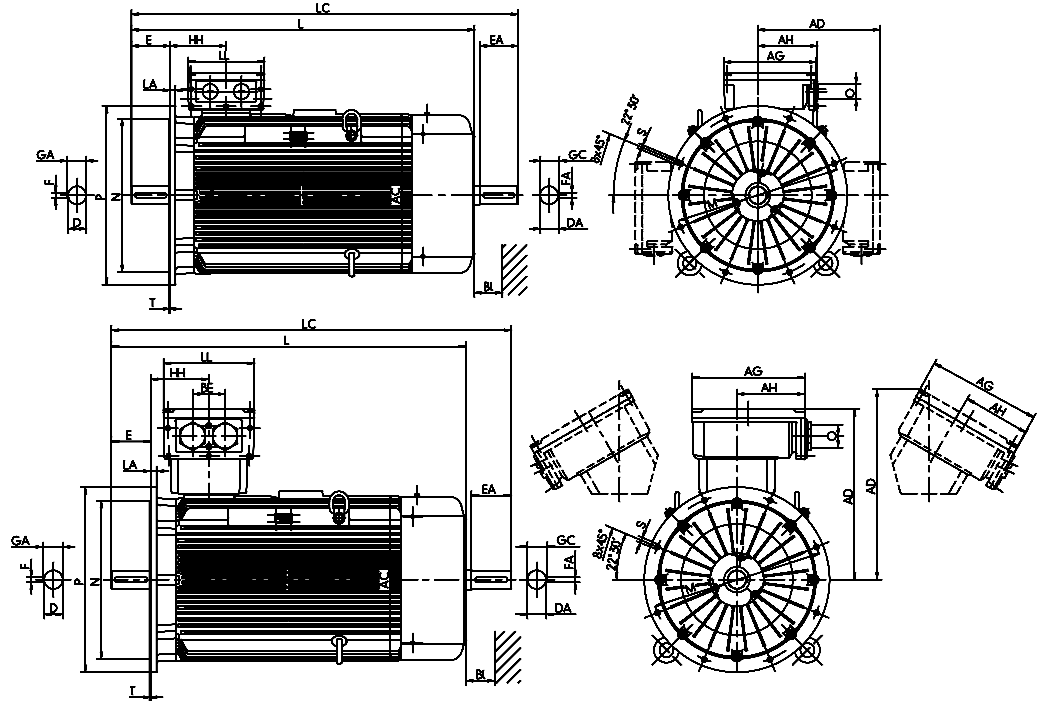

Type designation	Flange size	AC	AD	AD VIK	D	DA	DB ^{*)}	E	EA	F	FA	GA	GC	H	HH	K	K'
		g	g1	g1	d	d1		l	l1	u	u1	t	t1	h	A	s	s'
IE2-K11R 315 S2 Ex e IIC	A660	550	416	460.5	65	65	M20	140	140	18	18	69	69	315	211	28	35
IE2-K11R 315 M2 Ex e IIC	A660	550	416	460.5	65	65	M20	140	140	18	18	69	69	315	211	28	35
IE2-K11R 315 MX2 Ex e IIC	A660	550	416	460.5	65	65	M20	140	140	18	18	69	69	315	211	28	35
IE2-K11R 315 MY2 Ex e IIC	A660	610	494	680.5	65	65	M20	140	140	18	18	69	69	315	230	28	35
IE2-K11R 315 L2 Ex e IIC	A660	610	494	680.5	65	65	M20	140	140	18	18	69	69	315	230	28	35
IE2-K11R 315 LX2 Ex e IIC	A660	610	494	680.5	65	65	M20	140	140	18	18	69	69	315	230	28	35
IE2-K11R 315 S4 Ex e IIC	A660	550	416	461	80	70	M20	170	140	22	20	85	74.5	315	211	28	35
IE2-K11R 315 M4 Ex e IIC	A660	550	416	460.5	80	70	M20	170	140	22	20	85	74.5	315	211	28	35
IE2-K11R 315 MX4 Ex e IIC	A660	550	416	460.5	80	70	M20	170	140	22	20	85	74.5	315	211	28	35
IE2-K11R 315 MY4 Ex e IIC	A660	610	494	680.5	80	70	M20	170	140	22	20	85	74.5	315	230	28	35
IE2-K11R 315 L4 Ex e IIC	A660	610	494	680.5	80	70	M20	170	140	22	20	85	74.5	315	230	28	35
IE2-K11R 315 LX4 Ex e IIC	A660	610	494	680.5	80	70	M20	170	140	22	20	85	74.5	315	230	28	35
IE2-K11R 315 S6 Ex e IIC	A660	550	416	460.5	80	70	M20	170	140	22	20	85	74.5	315	211	28	35
IE2-K11R 315 M6 Ex e IIC	A660	550	416	460.5	80	70	M20	170	140	22	20	85	74.5	315	211	28	35
IE2-K11R 315 MX6 Ex e IIC	A660	610	494	680.5	80	70	M20	170	140	22	20	85	74.5	315	230	28	35
IE2-K11R 315 MY6 Ex e IIC	A660	610	494	680.5	80	70	M20	170	140	22	20	85	74.5	315	230	28	35
IE2-K11R 315 L6 Ex e IIC	A660	610	494	680.5	80	70	M20	170	140	22	20	85	74.5	315	230	28	35
IE2-K11R 315 LX6 Ex e IIC	A660	610	494	680.5	80	70	M20	170	140	22	20	85	74.5	315	230	28	35
IE2-K11R 315 S8 Ex e IIC	A660	550	416	460.5	80	70	M20	170	140	22	20	85	74.5	315	211	28	35
IE2-K11R 315 M8 Ex e IIC	A660	550	416	460.5	80	70	M20	170	140	22	20	85	74.5	315	211	28	35
IE2-K11R 315 MX8 Ex e IIC	A660	610	494	680.5	80	70	M20	170	140	22	20	85	74.5	315	230	28	35
IE2-K11R 315 MY8 Ex e IIC	A660	610	494	680.5	80	70	M20	170	140	22	20	85	74.5	315	230	28	35
IE2-K11R 315 L8 Ex e IIC	A660	610	494	680.5	80	70	M20	170	140	22	20	85	74.5	315	230	28	35
IE2-K11R 315 LX8 Ex e IIC	A660	610	494	680.5	80	70	M20	170	140	22	20	85	74.5	315	230	28	35
IE2-K12R 355 MY4 Ex e IIC	A800	715	736	736	100	80	M24	210	170	28	22	106	85	355	250	28	35
IE2-K12R 355 M4 Ex e IIC	A800	715	736	736	100	80	M24	210	170	28	22	106	85	355	250	28	35
IE2-K12R 355 MY6 Ex e IIC	A800	715	736	736	100	80	M24	210	170	28	22	106	85	355	250	28	35
IE2-K12R 355 M6 Ex e IIC	A800	715	736	736	100	80	M24	210	170	28	22	106	85	355	250	28	35
IE2-K12R 355 MX6 Ex e IIC	A800	715	736	736	100	80	M24	210	170	28	22	106	85	355	250	28	35
IE2-K12R 355 MX4 Ex e IIC	A800	715	729	729	100	80	M24	210	170	28	22	106	85	355	327	28	35
IE2-K12R 355 L4 Ex e IIC	A800	715	729	729	100	80	M24	210	170	28	22	106	85	355	327	28	35
IE2-K12R 355 L8 Ex e IIC	A800	715	729	729	100	80	M24	210	170	28	22	106	85	355	327	28	35

Type designation	L	L	LC	TB Type	AG	LL	AH	TB Type	AG	LL	AH	O	LB	BI
	k	IM V1 k	k1	Ex e IIC Standard	x	z	-	Ex e IIC VIK	x	z	-	-		BI
IE2-K11R 315 S2 Ex e IIC	1050	1160	1218	200 A	290	252	-	400 A-SB	415	340	265	M63 x 1.5	8L	55
IE2-K11R 315 M2 Ex e IIC	1105	1215	1273	200 A	290	252	-	400 A-SB	415	340	265	M63 x 1.5	8L	55
IE2-K11R 315 MX2 Ex e IIC	1185	1295	1353	200 A	290	252	-	400 A-SB	415	340	265	M63 x 1.5	8L	55
IE2-K11R 315 MY2 Ex e IIC	1270	1380	1448	630 A	496	390	301	630 A	496	390	301	M63 x 1.5	8L	55
IE2-K11R 315 L2 Ex e IIC	1390	1500	1568	630 A	496	390	301	630 A	496	390	301	M63 x 1.5	8L	55
IE2-K11R 315 LX2 Ex e IIC	1510	1620	1688	630 A	496	390	301	630 A	496	390	301	M63 x 1.5	8L	55
IE2-K11R 315 S4 Ex e IIC	1135	1234	1303	200 A	290	252	-	400 A-SB	415	340	265	M63 x 1.5	8L	55
IE2-K11R 315 M4 Ex e IIC	1135	1245	1303	200 A	290	252	-	400 A-SB	415	340	265	M63 x 1.5	8L	55
IE2-K11R 315 MX4 Ex e IIC	1210	1325	1383	200 A	290	252	-	400 A-SB	415	340	265	M63 x 1.5	8L	55
IE2-K11R 315 MY4 Ex e IIC	1300	1410	1478	630 A	496	390	301	630 A	496	390	301	M63 x 1.5	8L	55
IE2-K11R 315 L4 Ex e IIC	1420	1530	1598	630 A	496	390	301	630 A	496	390	301	M63 x 1.5	8L	55
IE2-K11R 315 LX4 Ex e IIC	1540	1650	1718	630 A	496	390	301	630 A	496	390	301	M63 x 1.5	8L	55
IE2-K11R 315 S6 Ex e IIC	1135	1245	1303	200 A	290	252	-	400 A-SB	415	340	265	M63 x 1.5	8L	55
IE2-K11R 315 M6 Ex e IIC	1135	1245	1303	200 A	290	252	-	400 A-SB	415	340	265	M63 x 1.5	8L	55
IE2-K11R 315 MX6 Ex e IIC	1300	1410	1478	630 A	496	390	301	630 A	496	390	301	M63 x 1.5	8L	55
IE2-K11R 315 MY6 Ex e IIC	1300	1410	1478	630 A	496	390	301	630 A	496	390	301	M63 x 1.5	8L	55
IE2-K11R 315 L6 Ex e IIC	1420	1530	1598	630 A	496	390	301	630 A	496	390	301	M63 x 1.5	8L	55
IE2-K11R 315 LX6 Ex e IIC	1420	1530	1598	630 A	496	390	301	630 A	496	390	301	M63 x 1.5	8L	55
IE2-K11R 315 S8 Ex e IIC	1135	1245	1303	200 A	290	252	-	400 A-SB	415	340	265	M63 x 1.5	8L	55
IE2-K11R 315 M8 Ex e IIC	1135	1245	1303	200 A	290	252	-	400 A-SB	415	340	265	M63 x 1.5	8L	55
IE2-K11R 315 MX8 Ex e IIC	1300	1410	1478	630 A	496	390	301	630 A	496	390	301	M63 x 1.5	8L	55
IE2-K11R 315 MY8 Ex e IIC	1300	1410	1478	630 A	496	390	301	630 A	496	390	301	M63 x 1.5	8L	55
IE2-K11R 315 L8 Ex e IIC	1420	1530	1598	630 A	496	390	301	630 A	496	390	301	M63 x 1.5	8L	55
IE2-K11R 315 LX8 Ex e IIC	1420	1530	1598	630 A	496	390	301	630 A	496	390	301	M63 x 1.5	8L	55
IE2-K12R 355 MY4 Ex e IIC	1570	1690	1755	630 A	496	390	301	630 A	496	390	301	M75 x 1.5	8L	60
IE2-K12R 355 M4 Ex e IIC	1570	1690	1755	630 A	496	390	301	630 A	496	390	301	M75 x 1.5	8L	60
IE2-K12R 355 MY6 Ex e IIC	1570	1690	1755	630 A	496	390	301	630 A	496	390	301	M75 x 1.5	8L	60
IE2-K12R 355 M6 Ex e IIC	1570	1690	1755	630 A	496	390	301	630 A	496	390	301	M75 x 1.5	8L	60
IE2-K12R 355 MX6 Ex e IIC	1690	1810	1875	630 A	496	390	301	630 A	496	390	301	M75 x 1.5	8L	60
IE2-K12R 355 MX4 Ex e IIC	1690	1810	1875	1000 A	615	474	385	1000 A	615	474	385	M75 x 1.5	8L	60
IE2-K12R 355 L4 Ex e IIC	1690	1810	1875	1000 A	615	474	385	1000 A	615	474	385	M75 x 1.5	8L	60
IE2-K12R 355 L8 Ex e IIC	1690	1810	1875	1000 A	615	474	385	1000 A	615	474	385	M75 x 1.5	8L	60

Three-phase motors with squirrel-cage rotor, High Efficiency IE2

Type of explosion protection – Increased safety „e“ („eb“) for operation in Zone 1 according to EN 60079-7 (VIK Recommendation 1, Three-Phase Asynchronous Motors – Technical Requirements 03.2011)

Low-noise design with direction-dependent fan

with surface cooling, type of cooling IC 411

Size 315, 355

Type of construction IM B5 [IM 3001], IM V1 [IM 3011]

Flange dimensions, see page 10/6

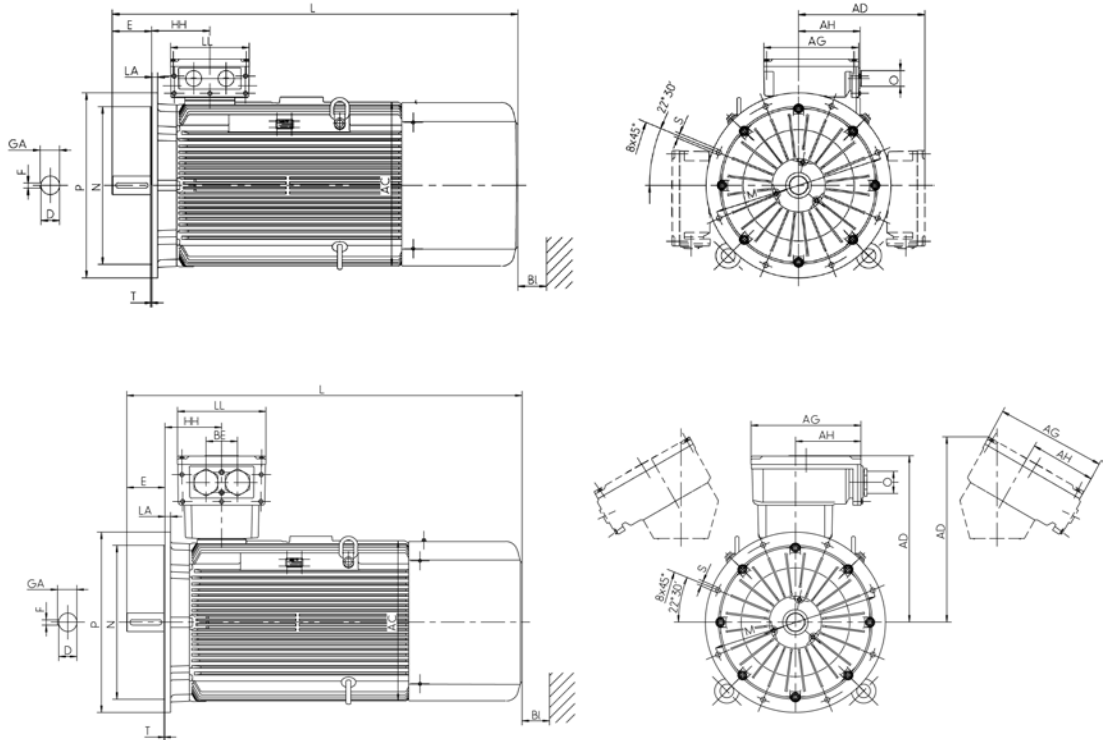

Type designation	Flange size	AC	AD	AD	D	DB ¹⁾	E	F	GA	H	HH	K	K'
		g	g1	VIK g1	d		l	u	t	h	A	s	s'
IE2-K11R 315 S2G Ex e IIC	A660	550	416	460.5	65	M20	140	18	69	315	211	28	35
IE2-K11R 315 M2G Ex e IIC	A660	550	416	460.5	65	M20	140	18	69	315	211	28	35
IE2-K11R 315 MX2G Ex e IIC	A660	550	416	460.5	65	M20	140	18	69	315	211	28	35
IE2-K11R 315 MY2G Ex e IIC	A660	610	494	680.5	65	M20	140	18	69	315	230	28	35
IE2-K11R 315 L2G Ex e IIC	A660	610	494	680.5	65	M20	140	18	69	315	230	28	35
IE2-K11R 315 LX2G Ex e IIC	A660	610	494	680.5	65	M20	140	18	69	315	230	28	35
IE2-K12R 355 MY2 Ex e IIC	A800	715	736	736	80	M20	170	22	85	355	250	28	35
IE2-K12R 355 M2 Ex e IIC	A800	715	736	736	80	M20	170	22	85	355	250	28	35
IE2-K12R 355 MX2G Ex e IIC	A800	715	729	729	80	M20	170	22	85	355	327	28	35
IE2-K12R 355 L2 Ex e IIC	A800	715	729	729	80	M20	170	22	85	355	327	28	35

¹⁾ Centre holes to DIN 332-DS ...

Type designation	L	L	TB Type	AG	LL	AH	TB Type	AG	LL	AH	O	LB	BI
	k	IM V1 k	Ex e IIC Standard	x	z	-	Ex e IIC VIK	x	z	-	-		BI
IE2-K11R 315 S2G Ex e IIC	1135	1245	200 A	290	252	-	400 A-SB	415	340	265	M63 x 1.5	8L	55
IE2-K11R 315 M2G Ex e IIC	1190	1300	200 A	290	252	-	400 A-SB	415	340	265	M63 x 1.5	8L	55
IE2-K11R 315 MX2G Ex e IIC	1270	1380	200 A	290	252	-	400 A-SB	415	340	265	M63 x 1.5	8L	55
IE2-K11R 315 MY2G Ex e IIC	1270	1380	630 A	496	390	301	630 A	496	390	301	M63 x 1.5	8L	55
IE2-K11R 315 L2G Ex e IIC	1510	1620	630 A	496	390	301	630 A	496	390	301	M63 x 1.5	8L	55
IE2-K11R 315 LX2G Ex e IIC	1630	1740	630 A	496	390	301	630 A	496	390	301	M63 x 1.5	8L	55
IE2-K12R 355 MY2 Ex e IIC	1530	1650	630 A	496	390	301	630 A	496	390	301	M75 x 1.5	8L	60
IE2-K12R 355 M2 Ex e IIC	1530	1650	630 A	496	390	301	630 A	496	390	301	M75 x 1.5	8L	60
IE2-K12R 355 MX2G Ex e IIC	1650	1770	1000 A	615	474	385	1000 A	615	474	385	M75 x 1.5	8L	60
IE2-K12R 355 L2 Ex e IIC	1650	1770	1000 A	615	474	385	1000 A	615	474	385	M75 x 1.5	8L	60

Three-phase motors with squirrel-cage rotor
Type of explosion protection – Increased safety „e“ („eb“), VIK version

with surface cooling, type of cooling IC 411, degree of protection IP 55
 Size 56 to 250

Type of construction IM B3 [IM 1001]

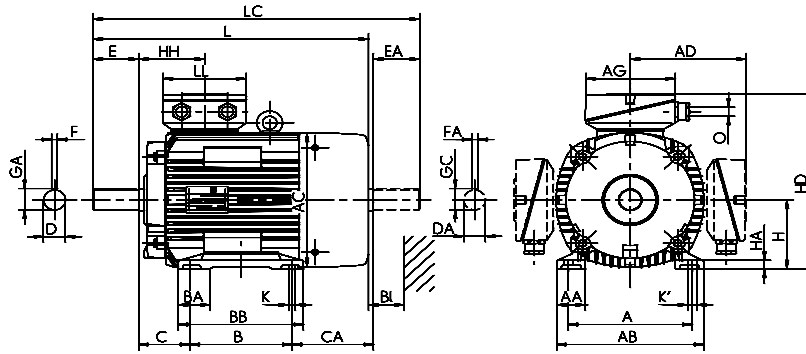

Type designation	Flange size	A	AA	AB	AC	AD	AD	B	BA	BB	C	CA	D	DA	DB ¹⁾	E	EA	F	FA
		b	n	f	g	g1	VIK	a	m	e	w1	w2	d	d1	l	l1	u	u1	
KPEO 56 K	A120	90	18	110	109	-	-	71	-	86	36	28	9	9	M3	20	20	3	3
KPER 56 G	A120	90	18	110	109	-	-	71	-	86	36	52	9	9	M3	20	20	3	3
KPER 63 K, L	A140	100	28	128	109	-	-	80	-	100	40	39	11	11	M4	23	23	4	4
KPER 71 K, L	A160	112	32	138	124	-	-	90	-	116	45	44	14	14	M5	30	30	5	5
KPER 80 K, L	A200	125	38	168	139	-	-	100	-	125	50	63	19	19	M6	40	40	6	6
KPER 90 S	A200	140	40	178	157	-	-	100	-	130	56	74	24	22	M8	50	50	8	6
KPER 90 L	A200	140	40	178	157	-	-	125	-	155	56	71	24	22	M8	50	50	8	6
KPER 100 L	A250	160	45	192	177	-	-	140	-	175	63	73	28	24	M10	60	50	8	8
KPER 100 LX4	A250	160	33	188	196	-	-	140	-	171	63	102	28	28	M10	60	60	8	8
KPER 112 M2	A250	190	50	224	196	-	-	140	-	180	70	95	28	28	M10	60	60	8	8
KPER 112 MX2	A250	190	50	224	196	-	-	140	-	180	70	129	28	28	M10	60	60	8	8
KPER 112 M4	A250	190	50	224	196	-	-	140	-	180	70	129	28	28	M10	60	60	8	8
KPER 132 S2T	A300	216	50	256	196	-	-	140	-	180	89	129	38	28	M10	80	60	10	8
KPER 132 S4T	A300	216	50	256	196	-	-	140	-	180	89	129	38	28	M10	80	60	10	8
K11R 132 S2	A300	216	50	256	217	178	178	140	55	180	89	153	38	32	M12	80	80	10	10
K11R 132 SX2	A300	216	50	256	258	178	178	140	47	180	89	176	38	38	M12	80	80	10	10
K12R 132 SX2	A300	216	50	256	258	178	178	140	47	180	89	176	38	38	M12	80	80	10	10
K11R 132 S4	A300	216	50	256	217	178	178	140	55	180	89	153	38	32	M12	80	80	10	10
K11R 132 M4	A300	216	50	256	258	199	199	178	55	218	89	138	38	38	M12	80	80	10	10
K11R 132 M6	A300	216	50	256	217	178	178	178	55	218	89	135	38	32	M12	80	80	10	10
K11R 132 MX6	A300	216	50	256	258	199	199	178	55	218	89	138	38	38	M12	80	80	10	10
K11R 132 M8	A300	216	50	256	217	178	178	178	55	218	89	135	38	32	M12	80	80	10	10
K11R 160 M2	A350	254	55	296	313	249	275	210	60	257	108	178	42	38	M16	110	80	12	10
K11R 160 MX2	A350	254	55	296	313	249	275	210	60	257	108	148	42	42	M16	110	110	12	12
K11R 160 L2	A350	254	55	296	313	249	275	254	60	301	108	142	42	42	M16	110	110	12	12
K11R 160 M4	A350	254	55	296	313	249	275	210	60	257	108	148	42	42	M16	110	110	12	12
K11R 160 L4	A350	254	55	296	313	249	275	254	60	301	108	142	42	42	M16	110	110	12	12
K11R 160 M6	A350	254	55	296	258	249	275	210	60	257	108	135	42	38	M16	110	80	12	10
K11R 160 L6	A350	254	55	296	313	249	275	254	60	301	108	142	42	42	M16	110	110	12	12
K11R 160 M8	A350	254	55	296	258	225	251	210	60	257	108	135	42	38	M16	110	80	12	10
K11R 160 MX8	A350	254	55	296	258	225	251	210	60	257	108	135	42	38	M16	110	80	12	10
K11R 180 M2	A350	279	62	328	351	261	242	241	65	288	121	169	48	48	M16	110	110	14	14
K11R 180 M4	A350	279	62	328	351	242	242	241	65	288	121	169	48	42	M16	110	110	14	12
K11R 180 L4	A350	279	62	328	351	261	261	279	65	326	121	176	48	48	M16	110	110	14	14
K11R 180 L6	A350	279	62	328	313	242	242	279	65	326	121	104	48	42	M16	110	110	14	12
K11R 200 L2	A400	318	70	372	351	261	301	305	70	360	133	138	55	48	M20	110	110	16	14
K11R 200 LX2	A400	318	70	372	390	300	300	305	70	360	133	193	55	55	M20	110	110	16	16
K11R 200 L4	A400	318	70	372	351	261	301	305	70	360	133	138	55	48	M20	110	110	16	14
K11R 200 L6	A400	318	70	372	351	261	301	305	70	360	133	138	55	48	M20	110	110	16	14
K11R 200 LX6	A400	318	70	372	351	261	301	305	70	360	133	138	55	48	M20	110	110	16	14
K11R 225 M2	A450	356	75	413	440	300	300	311	75	368	149	267	55	55	M20	110	110	16	16
K11R 225 S4	A450	356	75	413	440	300	300	286	75	343	149	262	60	55	M20	140	110	18	16
K11R 225 M4	A450	356	75	413	440	300	300	311	75	368	149	267	60	55	M20	140	110	18	16
K11R 225 M6	A450	356	75	413	390	300	300	311	75	368	149	171	60	55	M20	140	110	18	16
K11R 225 S8	A450	356	75	413	390	300	300	286	75	343	149	196	60	55	M20	140	110	18	16
K11R 250 M2	A550	406	84	469	490	358	324	349	84	412	168	275	60	55	M20	140	110	18	16
K11R 250 M4	A550	406	84	469	490	358	324	349	84	412	168	275	65	55	M20	140	110	18	16

Low voltage electrical machines

Three-phase motors with squirrel-cage rotor Type of explosion protection – Increased safety „e“ („eb“)

with surface cooling, type of cooling IC 411, degree of protection IP 55
Size 56 to 250

Type of construction IM B35 [IM 2001]

Flange dimensions, see page 10/6

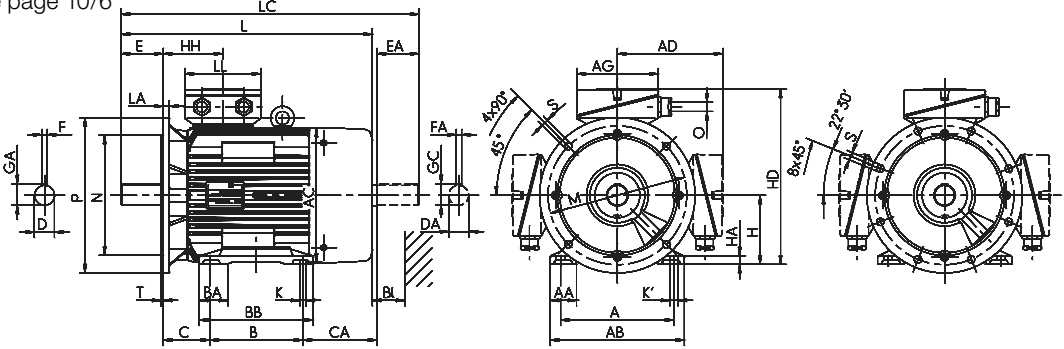

Type designation	GA	GC	H	HA	HD	HD**)	HD	HH	K	K'	L	L (IM V1)	LC	TB Type	AG	LL	O	TB Type	AG	LL	O	Hole pattern	BI
	t	t1	h	c	p	p	VIK	A	s	s'	k	k (IM V1)	k1	Ex e IIC Standard	-	-	-	Ex e IIC VIK	-	-	-	-	BI
KPE0 56 K	10.2	10.2	56	7	173	113	173	67	6	6	152	152	175	KA 05-13	104	112	M20 x 1.5	KA 05-13	104	112	M20 x 1.5	4L	-
KPER 56 G	10.2	10.2	56	7	173	113	173	67	6	6	177	198	199	KA 05-13	104	112	M20 x 1.5	KA 05-13	104	112	M20 x 1.5	4L	14
KPER 63 K, L	12.5	12.5	63	10	180	121	180	67	8	8	180	198	205	KA 05-13	104	112	M20 x 1.5	KA 05-13	104	112	M20 x 1.5	4L	14
KPER 71 K, L	16	16	71	11	194	133	194	70	8	8	207	225	239	KA 05-13	104	112	M20 x 1.5	KA 05-13	104	112	M20 x 1.5	4L	14
KPER 80 K, L	21.5	21.5	80	12	210	150	210	76	10	10	250	268	293	KA 05-13	104	112	M20 x 1.5	KA 05-13	104	112	M20 x 1.5	4L	16
KPER 90 S	27	24.5	90	14	229	170	229	79	10	10	276	294	330	KA 05-13	104	112	M25 x 1.5	KA 05-13	104	112	M25 x 1.5	4L	16
KPER 90 L	27	24.5	90	14	229	170	229	79	10	10	298	316	352	KA 05-13	104	112	M25 x 1.5	KA 05-13	104	112	M25 x 1.5	4L	16
KPER 100 L	31	27	100	15	246	189	246	84	12	12	332	350	386	KA 05-13	104	112	M25 x 1.5	KA 05-13	104	112	M25 x 1.5	4L	18
KPER 100 LX4	31	31	100	11	256	198	256	86	12	12	358	376	425	KA 05-13	104	112	M25 x 1.5	KA 05-13	104	112	M25 x 1.5	4L	20
KPER 112 M2	31	31	112	18	268	210	268	86	12	12	392	376	425	KA 05-13	104	112	M25 x 1.5	KA 05-13	104	112	M25 x 1.5	4L	20
KPER 112 MX2	31	31	112	18	268	210	268	86	12	12	392	376	459	KA 05-13	104	112	M25 x 1.5	KA 05-13	104	112	M25 x 1.5	4L	20
KPER 112 M4	31	31	112	18	268	210	268	86	12	12	392	376	459	KA 05-13	104	112	M25 x 1.5	KA 05-13	104	112	M25 x 1.5	4L	20
KPER 132 S2T	41	31	132	18	287	266	287	105	12	12	431	457	498	KA 05-13	104	112	M32 x 1.5	KA 05-13	104	112	M32 x 1.5	4L	20
KPER 132 S4T	41	31	132	18	287	266	287	105	12	12	460	480	528	KA 05-13	104	112	M32 x 1.5	KA 05-13	104	112	M32 x 1.5	4L	20
K11R 132 S2	41	35	132	16	310	257	310	108	12	12	459	499	542	25A	143	134	M32 x 1.5	25 AV	143	134	M32 x 1.5	4L	35
K11R 132 SX2	41	35	132	15	310	279	310	108	12	12	459	499	542	25A	143	134	M32 x 1.5	25 AV	143	134	M32 x 1.5	4L	35
K12R 132 SX2	41	35	132	15	310	279	310	108	12	12	530	570	613	25A	143	134	M32 x 1.5	25 AV	143	134	M32 x 1.5	4L	35
K11R 132 S4	41	35	132	16	310	257	310	108	12	12	459	499	542	25A	143	134	M32 x 1.5	25 AV	143	134	M32 x 1.5	4L	35
K11R 132 M4	41	41	132	16	331	279	331	114	12	12	481	521	565	25A	143	134	M32 x 1.5	25 AV	143	134	M32 x 1.5	4L	35
K11R 132 M6	41	35	132	16	310	257	310	108	12	12	479	519	562	25A	143	134	M32 x 1.5	25 AV	143	134	M32 x 1.5	4L	35
K11R 132 MX6	41	41	132	16	331	279	331	114	12	12	481	521	565	25A	143	134	M32 x 1.5	25 AV	143	134	M32 x 1.5	4L	35
K11R 132 M8	41	35	132	16	310	257	310	108	12	12	479	519	562	25A	143	134	M32 x 1.5	25 AV	143	134	M32 x 1.5	4L	35
K11R 160 M2	45	41	160	18	374	336	397	114	15	20	571	611	686	63A	184	172	M40 x 1.5	100/63 AV	223	214	M40 x 1.5	4L	35
K11R 160 MX2	45	45	160	18	402	336	402	138	15	20	571	611	686	63A	184	172	M40 x 1.5	100/63 AV	223	214	M40 x 1.5	4L	35
K11R 160 L2	45	45	160	18	402	336	402	138	15	20	609	649	724	63A	184	172	M40 x 1.5	100/63 AV	223	214	M40 x 1.5	4L	35
K11R 160 M4	45	45	160	18	374	336	374	114	15	20	571	611	686	63A	184	172	M40 x 1.5	100/63 AV	223	214	M40 x 1.5	4L	35
K11R 160L4	45	45	160	18	402	336	402	138	15	20	609	649	724	63A	184	172	M40 x 1.5	100/63 AV	223	214	M40 x 1.5	4L	35
K11R 160 M6	45	41	160	18	374	307	397	114	15	20	559	599	643	63A	184	172	M40 x 1.5	100/63 AV	223	214	M40 x 1.5	4L	35
K11R 160 L6	45	45	160	18	402	336	402	138	15	20	609	649	724	63A	184	172	M40 x 1.5	100/63 AV	223	214	M40 x 1.5	4L	35
K11R 160 M8	45	41	160	18	374	307	397	138	15	20	559	599	643	63A	184	172	M40 x 1.5	100/63 AV	223	214	M40 x 1.5	4L	35
K11R 160 MX8	45	41	160	18	374	307	397	138	15	20	559	599	643	63A	184	172	M40 x 1.5	100/63 AV	223	214	M40 x 1.5	4L	35
K11R 180 M2	51.5	51.5	180	20	441	369	422	147	15	20	635	675	751	63A	184	172	M40 x 1.5	100/63 AV	223	214	M40 x 1.5	4L	35
K11R 180 M4	51.5	45	180	20	441	369	422	138	15	20	635	675	751	63A	184	172	M40 x 1.5	100/63 AV	223	214	M40 x 1.5	4L	35
K11R 180 L4	51.5	51.5	180	20	441	369	441	147	15	20	680	720	796	63A	184	172	M40 x 1.5	100/63 AV	223	214	M40 x 1.5	4L	35
K11R 180 L6	51.5	45	180	20	422	369	402	138	15	20	609	649	724	63A	184	172	M40 x 1.5	100/63 AV	223	214	M40 x 1.5	4L	35
K11R 200 L2	59	51.5	200	22	461	389	501	147	19	25	680	720	796	100/63 AV	223	214	M50 x 1.5	100/63 AV	223	214	M50 x 1.5	4L	35
K11R 200 LX2	59	59	200	22	500	417	555	168	19	25	727	772	851	100A	222	214	M50 x 1.5	200 A-SB	335	270	M50 x 1.5	4L	35
K11R 200 L4	59	51.5	200	22	461	389	501	147	19	25	680	720	796	100A	222	214	M50 x 1.5	100/63 AV	223	214	M50 x 1.5	4L	35
K11R 200 L6	59	51.5	200	22	461	389	501	147	19	25	680	720	796	63A	184	172	M40 x 1.5	100/63 AV	223	214	M40 x 1.5	4L	35
K11R 200 LX6	59	51.5	200	22	461	389	501	147	19	25	680	720	796	100/63 AV	223	214	M50 x 1.5	100/63 AV	223	214	M50 x 1.5	4L	35
K11R 225 M2	59	59	225	25	525	459	555	168	19	25	832	917	947	100A	222	214	M50 x 1.5	200 A-SB	335	270	M50 x 1.5	8L	45
K11R 225 S4	64	59	225	25	525	459	555	168	19	25	862	947	977	100A	222	214	M50 x 1.5	200 A-SB	335	270	M50 x 1.5	8L	45
K11R 225 M4	64	59	225	25	525	459	555	168	19	25	862	947	977	100A	222	214	M50 x 1.5	200 A-SB	335	270	M50 x 1.5	8L	45
K11R 225 M6	64	59	225	25	525	442	555	168	19	25	757	842	881	100A	222	214	M50 x 1.5	200 A-SB	335	270	M50 x 1.5	8L	40
K11R 225 S8	64	59	225	25	525	442	555	168	19	25	757	802	881	100A	222	214	M50 x 1.5	200 A-SB	335	270	M50 x 1.5	8L	40
K11R 250 M2	64	59	250	28	608	516	604	177	24	30	924	1010	1042	200A	290	252	M63 x 1.5	200 A-SB	335	270	M63 x 1.5	8L	50
K11R 250 M4	69	59	250	28	608	516	604	177	24	30	924	1010	1042	200A	290	252	M63 x 1.5	200 A-SB	335	270	M63 x 1.5	8L	50

*) Terminal box left/right

Three-phase motors with squirrel-cage rotor
Type of explosion protection – Increased safety „e“ („eb“)
Low-noise design with direction-dependent fan

with surface cooling, type of cooling IC 411, degree of protection IP 55
 Size 132 to 250

Type of construction IM B3 [IM 1001]

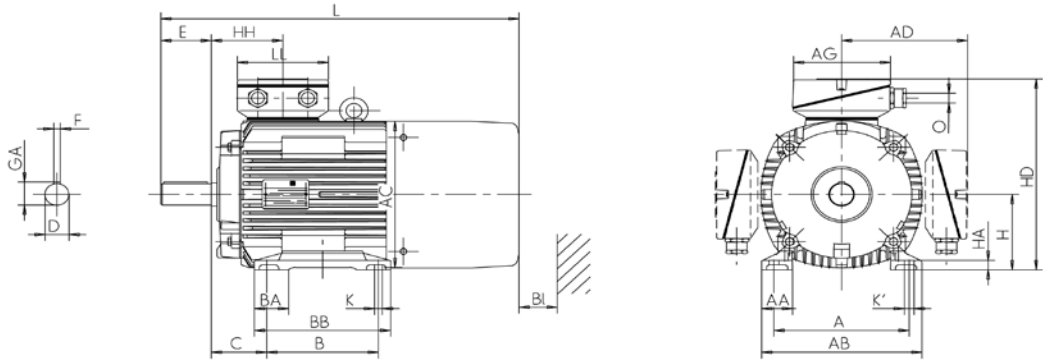

Type designation	Flange size	A	AA	AB	AC	AD	AD	B	BA	BB	C	D	DB ¹⁾	E	F
		b	n	f	g	g1	VIK	a	m	e	w1	d		l	u
K11R 132 S2G	A300	216	50	256	217	178	178	140	55	180	89	38	M12	80	10
K11R 132 SX2G	A300	216	50	256	258	178	178	140	47	180	89	38	M12	80	10
K12R 132 SX2G	A300	216	50	256	258	178	178	140	47	180	89	38	M12	80	10
K11R 160 M2G	A350	254	55	296	313	249	275	210	60	257	108	42	M16	110	12
K11R 160 MX2G	A350	254	55	296	313	249	275	210	60	257	108	42	M16	110	12
K11R 160 L2G	A350	254	55	296	313	249	275	254	60	301	108	42	M16	110	12
K11R 180 M2G	A350	279	62	328	351	261	261	241	65	288	121	48	M16	110	14
K11R 200 L2G	A400	318	70	372	351	261	301	305	70	360	133	55	M20	110	16
K11R 200 LX2G	A400	318	70	372	390	300	300	305	70	360	133	55	M20	110	16
K11R 225 M2G	A450	356	75	413	440	300	300	311	75	368	149	55	M20	110	16
K11R 250 M2G	A550	406	84	469	490	358	324	349	84	412	168	60	M20	140	18

¹⁾ Centre holes to DIN 332-DS ...

Three-phase motors with squirrel-cage rotor
Type of explosion protection – Increased safety „e“ („eb“)
Low-noise design with direction-dependent fan

with surface cooling, type of cooling IC 411, degree of protection IP 55
 Size 132 to 250

Type of construction IM B35 [IM 2001]

Flange dimensions, see page 10/6

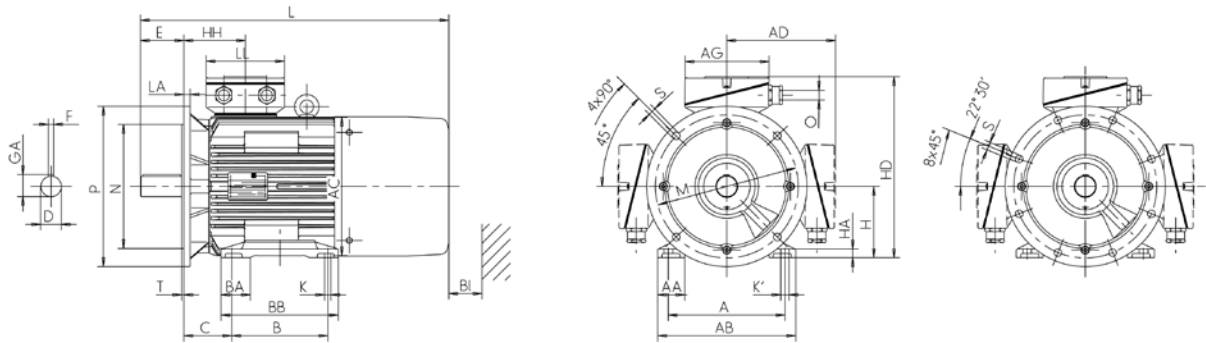

Type designation	GA	H	HA	HD	HD ^{**})	HD	HH	K	K'	L	L	TB Type	AG	LL	O	TB Type	AG	LL	O	Hole pattern	BI
	t	h	c	p	p	VIK	A	s	s'	k	k	Ex e IIC Standard			-	Ex e IIC VIK					BI
K11R 132 S2G	41	132	16	310	257	310	108	12	12	584	624	25 A	143	134	M32 x 1.5	25 AV	143	134	M32 x 1.5	4L	35
K11R 132 SX2G	41	132	15	310	279	310	108	12	12	584	624	25 A	143	134	M32 x 1.5	25 AV	143	134	M32 x 1.5	4L	35
K12R 132 SX2G	41	132	15	310	279	310	108	12	12	644	684	25 A	143	134	M32 x 1.5	25 AV	143	134	M32 x 1.5	4L	35
K11R 160 M2G	45	160	18	374	336	374	114	15	20	699	739	25 A	143	134	M32 x 1.5	100/63 AV	223	214	M32 x 1.5	4L	35
K11R 160 MX2G	45	160	18	402	336	402	138	15	20	699	739	63 A	184	172	M40 x 1.5	100/63 AV	223	214	M40 x 1.5	4L	35
K11R 160 L2G	45	160	18	402	336	402	138	15	20	737	777	63 A	184	172	M40 x 1.5	100/63 AV	223	214	M40 x 1.5	4L	35
K11R 180 M2G	51.5	180	20	441	369	441	147	15	20	782	822	63 A	184	172	M40 x 1.5	100/63 AV	223	214	M40 x 1.5	4L	35
K11R 200 L2G	59	200	22	461	389	501	147	19	25	827	867	100/63 AV	223	214	M50 x 1.5	100/63 AV	223	214	M50 x 1.5	4L	35
K11R 200 LX2G	59	200	22	500	417	555	168	19	25	790	835	100 A	222	214	M50 x 1.5	200 A-SB	335	270	M50 x 1.5	4L	35
K11R 225 M2G	59	225	25	525	459	555	168	19	25	897	952	100 A	222	214	M50 x 1.5	200 A-SB	335	270	M50 x 1.5	8L	45
K11R 250 M2G	64	250	28	608	516	604	177	24	30	1004	1090	200 A	290	252	M63 x 1.5	200 A-SB	335	270	M63 x 1.5	8L	50

** Terminal box left/right

Three-phase motors with squirrel-cage rotor Type of explosion protection – Increased safety „e“ („eb“)

with surface cooling, type of cooling IC 411, degree of protection IP 55
Size 280 to 315

Type of construction IM B3 [IM 1001]

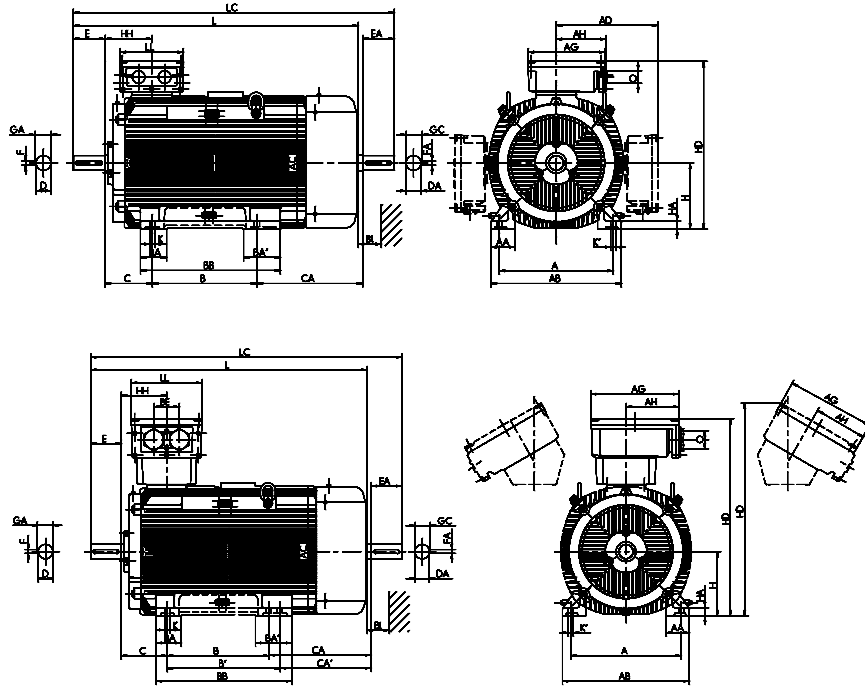

Type designation	Flange size	A	AA	AB	AC	AD	AD	B	B'	BA	BA'	BB	C	CA	D	DA	DB ^{*)}	E	EA	F	FA
		VIK																			
		b	n	f	g	g1	g1	a	a'	m	m1	e	w1	w2	d	d1	l	l1	u	u1	
K11R 280 S2	A550	457	94	522	550	386	386	368	-	96	-	431	190	380	65	65	M20	140	140	18	18
K11R 280 M2	A550	457	94	522	550	386	386	419	-	96	-	482	190	384	65	65	M20	140	140	18	18
K11R 280 S4	A550	457	94	522	550	386	386	368	-	96	-	431	190	380	75	65	M20	140	140	20	18
K11R 280 M4	A550	457	94	522	550	386	386	419	-	96	-	482	190	384	75	65	M20	140	140	20	18
K11R 280 S6	A660	457	88	522	550	386	386	368	-	-	-	431	190	380	80	70	M20	140	140	20	18
K11R 315 S2	A660	508	132	590	550	416	451	406	-	120	-	554	216	371	65	65	M20	140	140	18	18
K11R 315 M2	A660	508	132	590	550	416	451	457	-	120	-	554	216	400	65	65	M20	140	140	18	18
K11R 315 MX2	A660	508	126	590	550	416	451	406	457	120	150	554	216	400	65	65	M20	140	140	18	18
K11R 315 MY2	A660	508	110	590	610	498	681	457	-	120	-	573	216	495	65	65	M20	140	140	18	18
K11R 315 S4	A660	508	132	590	550	416	451	406	-	120	-	554	216	371	80	70	M20	170	140	22	20
K11R 315 M4	A660	508	132	590	550	416	451	457	-	120	-	554	216	400	80	70	M20	170	140	22	20
K11R 315 MX4	A660	508	126	590	550	416	451	406	457	120	150	554	216	400	80	70	M20	170	140	22	20
K11R 315 MY4	A660	508	110	590	610	498	681	457	-	120	-	573	216	495	80	70	M20	170	140	22	20
K11R 315 L4	A660	508	110	590	610	498	681	508	-	120	-	624	216	564	80	70	M20	170	140	22	20
K11R 315 MX6	A660	508	126	590	550	416	451	406	457	120	150	554	216	320	80	70	M20	170	140	22	20
K11R 315 L2	A660	508	110	590	610	681	681	508	-	120	-	624	216	539	65	65	M20	140	140	18	18
K11R 315 LX2	A660	508	110	590	610	681	681	508	-	120	-	624	216	684	65	65	M20	140	140	18	18
K11R 315 LX4	A660	508	110	590	610	681	681	508	-	120	-	624	216	689	80	70	M20	170	140	22	20
K11R 315 LX6	A660	508	110	590	610	681	681	508	-	120	-	624	216	564	80	70	M20	170	140	22	20

^{*)} Centre holes to DIN 332-DS ...

Three-phase motors with squirrel-cage rotor Type of explosion protection – Increased safety „e“ („eb“)

with surface cooling, type of cooling IC 411, degree of protection IP 55
Size 280 to 315

Type of construction IM B35 [IM 2001]

Flange dimensions, see page 10/6

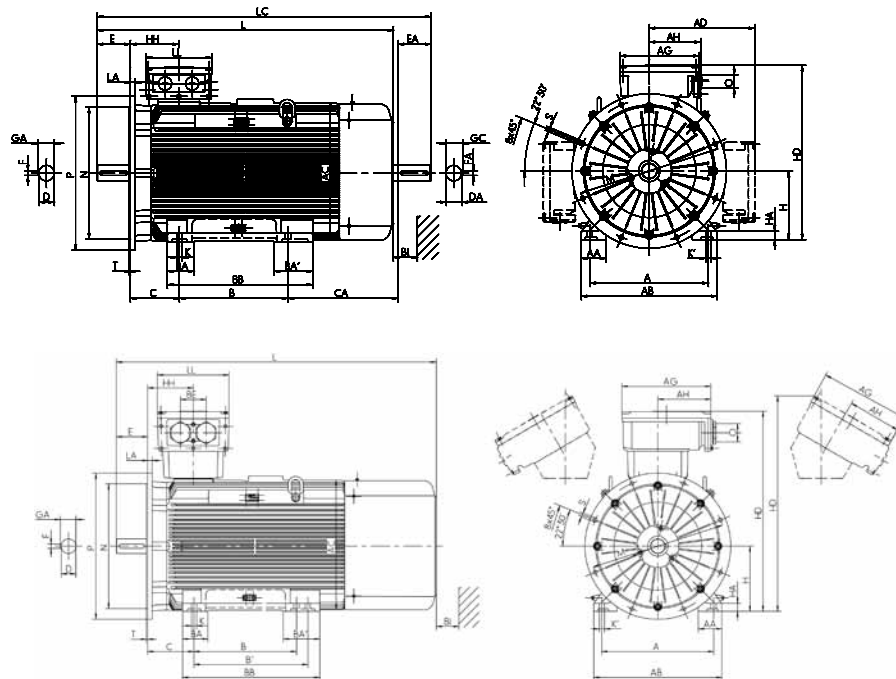

Type designation	GA	GC	H	HA	HD	HD ^{*)}	HD	HH	K	K'	L	L	LC	TB Type	AG	LL	AH	TB Type	AG	LL	AH	O	BI
	t	t1	h	c	p	p	p	A	s	s'	k	k	k1	Ex e IIC Standard			-	Ex e IIC VIK	x	z	-	r	BI
K11R 280 S2	69	69	280	40	666	560	666	206	24	30	1050	1149	1218	200 A	290	252	-	200 A-SB	335	270	200	M63 x 1.5	55
K11R 280 M2	69	69	280	40	666	560	666	206	24	30	1105	1204	1273	200 A	290	252	-	200 A-SB	335	270	200	M63 x 1.5	55
K11R 280 S4	79.5	69	280	40	666	560	666	206	24	30	1050	1149	1218	200 A	290	252	-	200 A-SB	335	270	200	M63 x 1.5	55
K11R 280 M4	79.5	69	280	40	666	560	666	206	24	30	1105	1204	1273	200 A	290	252	-	200 A-SB	335	270	200	M63 x 1.5	55
K11R 280 S6	79.5	69	280	40	666	560	666	206	24	30	1080	1179	1248	200 A	290	252	-	200 A-SB	335	270	200	M63 x 1.5	55
K11R 315 S2	69	69	315	44	731	595	766	211	28	35	1105	1204	1273	200 A	290	252	-	400 A-SB	415	340	265	M63 x 1.5	55
K11R 315 M2	69	69	315	44	731	595	766	211	28	35	1185	1284	1353	200 A	290	252	-	400 A-SB	415	340	265	M63 x 1.5	55
K11R 315 MX2	69	69	315	44	731	595	766	211	28	35	1185	1284	1353	400 A-SB	415	340	265	630 A	496	390	301	M63 x 1.5	55
K11R 315 MY2	69	69	315	44	808	628	996	230	28	35	1270	1385	1448	400 A-SB	415	340	265	630 A	496	390	301	M63 x 1.5	55
K11R 315 S4	85	74.5	315	44	731	595	760	211	28	35	1135	1234	1303	400 A-SB	415	340	265	630 A	496	390	301	M63 x 1.5	55
K11R 315 M4	85	74.5	315	44	731	595	760	211	28	35	1215	1314	1383	400 A-SB	415	340	265	630 A	496	390	301	M63 x 1.5	55
K11R 315 MX4	85	74.5	315	44	731	595	760	211	28	35	1215	1314	1383	400 A-SB	415	340	265	630 A	496	390	301	M63 x 1.5	55
K11R 315 MY4	85	74.5	315	44	808	628	996	230	28	35	1300	1415	1478	400 A-SB	415	340	265	630 A	496	390	301	M63 x 1.5	55
K11R 315 L4	85	74.5	315	44	808	628	996	230	28	35	1420	1535	1598	400 A-SB	415	340	265	630 A	496	390	301	M63 x 1.5	55
K11R 315 MX6	85	74.5	315	44	731	595	760	211	28	35	1135	1234	1303	400 A-SB	415	340	265	630 A	496	390	301	M63 x 1.5	55
K11R 315 L2	69	69	315	44	996	628	996	230	28	35	1390	1505	1543	630 A	496	390	301	630 A	496	390	301	M75 x 1.5	55
K11R 315 LX2	69	69	315	44	996	628	996	230	28	35	1510	1625	1688	630 A	496	390	301	630 A	496	390	301	M75 x 1.5	55
K11R 315 LX4	85	74.5	315	44	996	628	996	230	28	35	1540	1655	1723	630 A	496	390	301	630 A	496	390	301	M75 x 1.5	55
K11R 315 LX6	85	74.5	315	44	996	628	996	230	28	35	1420	1535	1598	630 A	496	390	301	630 A	496	390	301	M75 x 1.5	55

*) Terminal box left/right

Three-phase motors with squirrel-cage rotor
Type of explosion protection – Increased safety „e“ („eb“)
Low-noise design with direction-dependent fan

with surface cooling, type of cooling IC 411, degree of protection IP 55
 Size 280 to 315

Type of construction IM B3 [IM 1001]

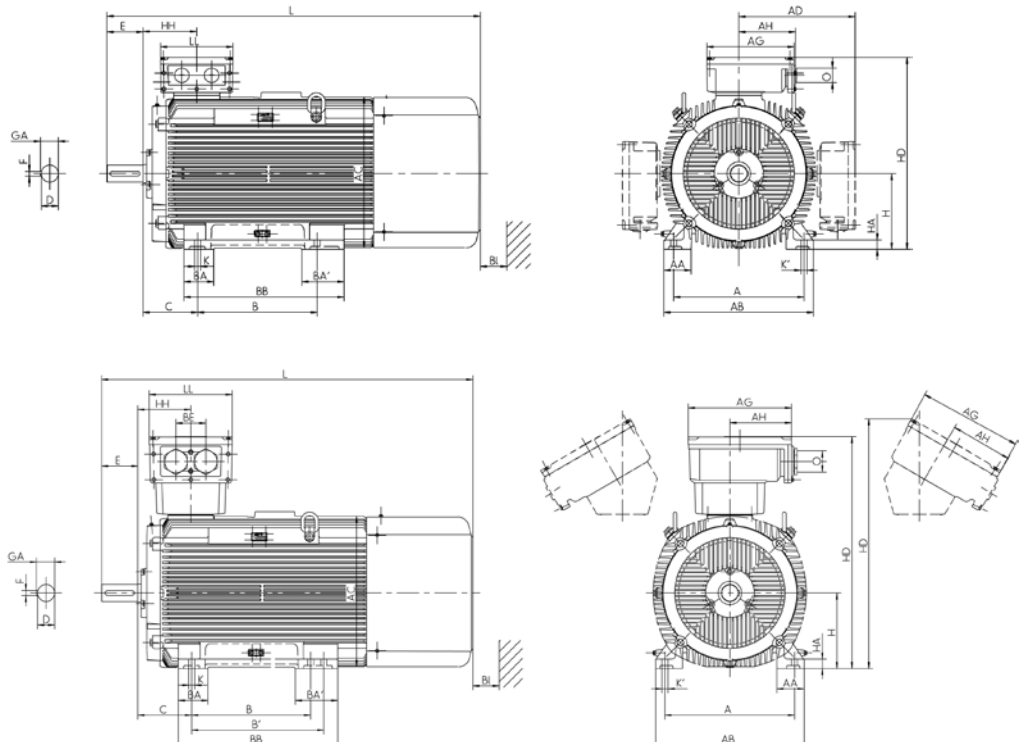

Type designation	Flange size	A	AA	AB	AC	AD	AD	B	B'	BA	BA'	BB	C	CA	D	DB ¹⁾	E	F
		b	n	f	g	g1	g1	a	a'	m	m1	e	w1	w2	d		l	u
K11R 280 S2G	A550	457	94	522	550	386	386	368	-	96	-	431	190	380	65	M20	140	18
K11R 280 M2G	A550	457	94	522	550	386	386	419	-	96	-	482	190	384	65	M20	140	18
K11R 315 S2G	A660	508	132	590	550	416	451	406	-	120	-	554	216	371	65	M20	140	18
K11R 315 M2G	A660	508	132	590	550	416	451	457	-	120	-	554	216	400	65	M20	140	18
K11R 315 MX2G	A660	508	126	590	550	416	451	406	457	120	150	554	216	400	65	M20	140	18
K11R 315 MY2G	A660	508	110	590	610	493	681	457	-	120	-	573	216	495	65	M20	140	18
K11R 315 L2G	A660	508	110	590	610	681	681	508	-	120	-	624	216	539	65	M20	140	18
K11R 315 LX2G	A660	508	110	590	610	681	681	508	-	120	-	624	216	684	65	M20	140	18

¹⁾ Centre holes to DIN 332-DS ...

Three-phase motors with squirrel-cage rotor
Type of explosion protection – Increased safety „e“ („eb“)
Low-noise design with direction-dependent fan

with surface cooling, type of cooling IC 411, degree of protection IP 55
 Size 280 to 315

Type of construction IM B35 [IM 2001]

Flange dimensions, see page 10/6

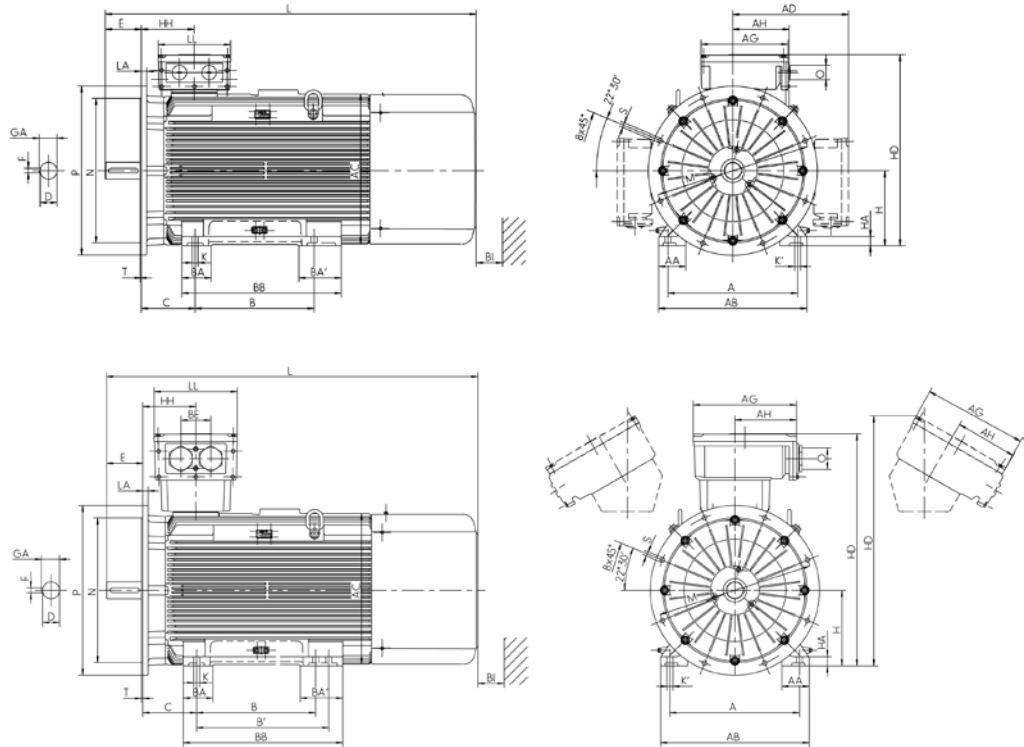

Type designation	GA	H	HA	HD	HD**)	HD	HH	K	K'	L	L (IM V1)	TB Type	AG	LL	AH	TB Type	AG	LL	AH	O	BI
	t	h	c	p	p	VIK	A	s	s'	k	k (IM V1)	Ex e IIC Standard			-	Ex e IIC VIK	x	z	-	r	BI
K11R 280 S2G	69	280	40	666	560	666	206	24	30	1135	1234	200 A	290	252	-	200 A-SB	335	270	200	M63 x 1.5	55
K11R 280 M2G	69	280	40	666	560	666	206	24	30	1190	1289	200 A	290	252	-	200 A-SB	335	270	200	M63 x 1.5	55
K11R 315 S2G	69	315	44	731	595	766	211	28	35	1190	1289	200 A	290	252	-	200 A-SB	335	270	200	M63 x 1.5	55
K11R 315 M2G	69	315	44	731	595	766	211	28	35	1270	1369	200 A	290	252	-	200 A-SB	335	270	200	M63 x 1.5	55
K11R 315 MX2G	69	315	44	731	595	766	211	28	35	-	-	400 A-SB	415	340	265	630 A	496	390	301	M63 x 1.5	55
K11R 315 MY2G	69	315	44	808	628	996	230	28	35	1390	1505	400 A-SB	415	340	265	630 A	496	390	301	M63 x 1.5	55
K11R 315 L2G	69	315	44	996	628	996	230	28	35	1510	1625	630 A	496	390	301	630 A	496	390	301	M75 x 1.5	55
K11R 315 LX2G	69	315	44	996	628	996	230	28	35	1510	1625	630 A	496	390	301	630 A	496	390	301	M75 x 1.5	55

** Terminal box left/right

Three-phase motors with squirrel-cage rotor
Type of explosion protection – Increased safety „e“ („eb“)

with surface cooling, type of cooling IC 411, degree of protection IP 55
 Size 56 to 180

Type of construction IM B14 [IM 3601]

Flange dimensions, see page 10/6

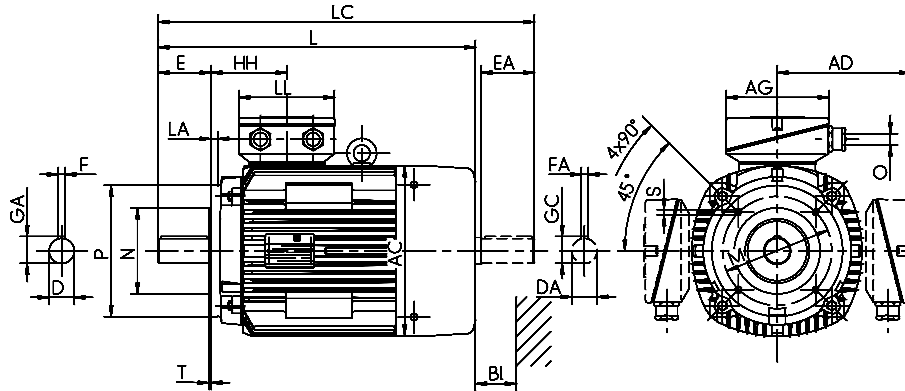

Type designation	Flange size		A	AA	AB	AC	AD	AD	B	BA	BB	C	CA	D	DA	DB ¹⁾	E	EA	F	FA
	small	large	b	n	f	g	g1	g1	a	m	e	w1	w2	d	d1		l	l1	u	u1
KPE0 56 K	C80	C105	90	18	110	109	-	-	71	-	86	36	28	9	9	M3	20	20	3	3
KPER 56 G	C80	C105	90	18	110	109	-	-	71	-	86	36	52	9	9	M3	20	20	3	3
KPER 63 K, L	C90	C120	100	28	128	109	-	-	80	-	100	40	39	11	11	M4	23	23	4	4
KPER 71 K, L	C105	C140	112	32	138	124	-	-	90	-	116	45	44	14	14	M5	30	30	5	5
KPER 80 K, L	C120	C160	125	38	168	139	-	-	100	-	125	50	63	19	19	M6	40	40	6	6
KPER 90 S	C140	C160	140	40	178	157	-	-	100	-	130	56	74	24	22	M8	50	50	8	6
KPER 90 L	C140	C160	140	40	178	157	-	-	125	-	155	56	71	24	22	M8	50	50	8	6
KPER 100 L	C160	C200	160	45	192	177	-	-	140	-	175	63	73	28	24	M10	60	50	8	8
KPER 100 LX4	C160	C200	160	33	188	196	-	-	140	-	171	63	102	28	28	M10	60	60	8	8
KPER 112 M2	C160	C200	190	50	224	196	-	-	140	-	180	70	95	28	28	M10	60	60	8	8
KPER 112 MX2	C160	C200	190	50	224	196	-	-	140	-	180	70	129	28	28	M10	60	60	8	8
KPER 112 M4	C160	C200	190	50	224	196	-	-	140	-	180	70	129	28	28	M10	60	60	8	8
KPER 132 S2T	C160	C200	216	50	256	196	-	-	140	-	180	89	129	38	28	M10	80	60	10	8
KPER 132 S4T	C160	C200	216	50	256	196	-	-	140	-	180	89	129	38	28	M10	80	60	10	8
K11R 132 S2	C160	C200	216	50	256	217	178	178	140	55	180	89	153	38	32	M12	80	80	10	10
K11R 132 SX2	C160	C200	216	50	256	258	178	178	140	47	180	89	176	38	38	M12	80	80	10	10
K12R 132 SX2	C160	C200	216	50	256	258	178	178	140	47	180	89	176	38	38	M12	80	80	10	10
K11R 132 S4	C160	C200	216	50	256	217	178	178	140	55	180	89	153	38	32	M12	80	80	10	10
K11R 132 M4	C200	C250	216	50	256	258	199	199	178	55	218	89	138	38	38	M12	80	80	10	10
K11R 132 M6	C160	C200	216	50	256	217	178	178	178	55	218	89	135	38	32	M12	80	80	10	10
K11R 132 MX6	C200	C250	216	50	256	258	199	199	178	55	218	89	138	38	38	M12	80	80	10	10
K11R 132 M8	C160	C200	216	50	256	217	178	178	178	55	218	89	135	38	32	M12	80	80	10	10
K11R 160 M2	C250	C300	254	55	296	313	214	237	210	60	257	108	178	42	38	M16	110	80	12	10
K11R 160 MX2	C250	C300	254	55	296	313	242	242	210	60	257	108	148	42	42	M16	110	110	12	12
K11R 160 L2	C250	C300	254	55	296	313	242	242	254	60	301	108	142	42	42	M16	110	110	12	12
K11R 160 M4	C250	C300	254	55	296	313	214	214	210	60	257	108	148	42	42	M16	110	110	12	12
K11R 160 L4	C250	C300	254	55	296	313	242	242	254	60	301	108	142	42	42	M16	110	110	12	12
K11R 160 M6	C200	C250	254	55	296	258	214	214	210	60	257	108	135	42	38	M16	110	80	12	10
K11R 160 L6	C250	C300	254	55	296	313	242	242	254	60	301	108	142	42	42	M16	110	110	12	12
K11R 160 M8	C200	C250	254	55	296	258	214	237	210	60	257	108	135	42	38	M16	110	80	12	10
K11R 160 MX8	C200	C250	254	55	296	258	214	237	210	60	257	108	135	42	38	M16	110	80	12	10
K11R 180 M4	C300	0	279	62	328	351	242	242	241	65	288	121	169	48	42	M16	110	110	14	12
K11R 180 L6	C300	0	279	62	328	313	242	242	279	65	326	121	104	48	42	M16	110	110	14	12

¹⁾ Centre holes to DIN 332-DS ...

Three-phase motors with squirrel-cage rotor
Type of explosion protection – Increased safety „e“ („eb“)

with surface cooling, type of cooling IC 411, degree of protection IP 55
 Size 56 to 180

Type of construction IM B34 [IM 2101]

Flange dimensions, see page 10/6

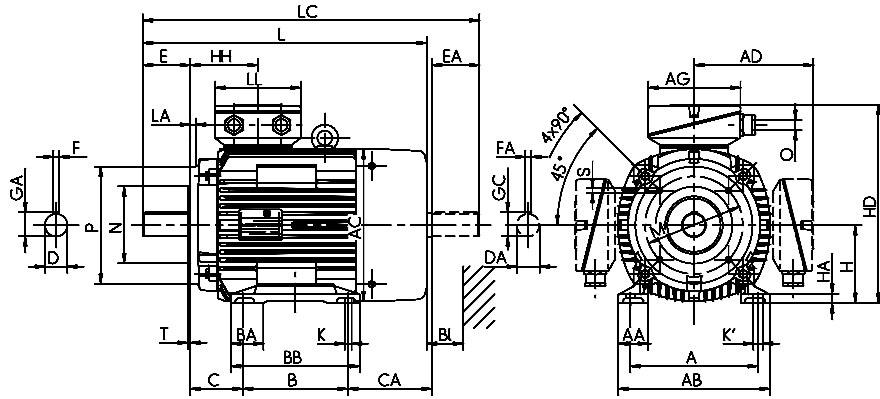

Type designation	GA	GC	H	HA	HD	HD ^{*)}	HD	HH	K	K'	L	L	LC	TB Type	AG	LL	O	TB Type	AG	LL	O	LB	BI
	t	t1	h	c	p	p	p	A	s	s'	k	k	k1	Ex e IIC Standard			-	Ex e IIC VIK	x	z	r		BI
KPE0 56 K	10.2	10.2	56	7	173	113	-	67	6	6	152	152	175	KA 05-13	104	112	M20 x 1.5	KA 05-13	104	112	M20 x 1.5	4L	-
KPER 56 G	10.2	10.2	56	7	173	113	-	67	6	6	177	198	199	KA 05-13	104	112	M20 x 1.5	KA 05-13	104	112	M20 x 1.5	4L	14
KPER 63 K, L	12.5	12.5	63	10	180	121	-	67	8	8	180	198	205	KA 05-13	104	112	M20 x 1.5	KA 05-13	104	112	M20 x 1.5	4L	14
KPER 71 K, L	16	16	71	11	194	133	-	70	8	8	207	225	239	KA 05-13	104	112	M20 x 1.5	KA 05-13	104	112	M20 x 1.5	4L	14
KPER 80 K, L	21.5	21.5	80	12	210	150	-	76	10	10	250	268	293	KA 05-13	104	112	M20 x 1.5	KA 05-13	104	112	M20 x 1.5	4L	16
KPER 90 S	27	24.5	90	14	229	170	-	79	10	10	276	294	330	KA 05-13	104	112	M25 x 1.5	KA 05-13	104	112	M25 x 1.5	4L	16
KPER 90 L	27	24.5	90	14	229	170	-	79	10	10	298	316	352	KA 05-13	104	112	M25 x 1.5	KA 05-13	104	112	M25 x 1.5	4L	16
KPER 100 L	31	27	100	15	246	189	-	84	12	12	332	350	386	KA 05-13	104	112	M25 x 1.5	KA 05-13	104	112	M25 x 1.5	4L	18
KPER 100 LX4	31	31	100	11	256	198	-	86	12	12	358	376	425	KA 05-13	104	112	M25 x 1.5	KA 05-13	104	112	M25 x 1.5	4L	20
KPER 112 M2	31	31	112	18	268	210	-	86	12	12	392	376	425	KA 05-13	104	112	M25 x 1.5	KA 05-13	104	112	M25 x 1.5	4L	20
KPER 112 MX2	31	31	112	18	268	210	-	86	12	12	392	376	459	KA 05-13	104	112	M25 x 1.5	KA 05-13	104	112	M25 x 1.5	4L	20
KPER 112 M4	31	31	112	18	268	210	-	86	12	12	392	376	459	KA 05-13	104	112	M25 x 1.5	KA 05-13	104	112	M25 x 1.5	4L	20
KPER 132 S2T	41	31	132	18	287	266	-	105	12	12	431	457	498	KA 05-13	104	112	M32 x 1.5	KA 05-13	104	112	M32 x 1.5	4L	20
KPER 132 S4T	41	31	132	18	287	266	-	105	12	12	460	480	528	KA 05-13	104	112	M32 x 1.5	KA 05-13	104	112	M32 x 1.5	4L	20
K11R 132 S2	41	35	132	16	310	257	310	108	12	12	459	499	542	25A	143	134	M32 x 1.5	25 AV	143	134	M32 x 1.5	4L	35
K11R 132 SX2	41	35	132	15	310	279	310	108	12	12	459	499	542	25A	143	134	M32 x 1.5	25 AV	143	134	M32 x 1.5	4L	35
K12R 132 SX2	41	35	132	15	310	279	310	108	12	12	530	570	613	25A	143	134	M32 x 1.5	25 AV	143	134	M32 x 1.5	4L	35
K11R 132 S4	41	35	132	16	310	257	310	108	12	12	459	499	542	25A	143	134	M32 x 1.5	25 AV	143	134	M32 x 1.5	4L	35
K11R 132 M4	41	41	132	16	331	279	331	114	12	12	481	521	565	25A	143	134	M32 x 1.5	25 AV	143	134	M32 x 1.5	4L	35
K11R 132 M6	41	35	132	16	310	257	310	108	12	12	479	519	562	25A	143	134	M32 x 1.5	25 AV	143	134	M32 x 1.5	4L	35
K11R 132 MX6	41	41	132	16	331	279	331	114	12	12	481	521	565	25A	143	134	M32 x 1.5	25 AV	143	134	M32 x 1.5	4L	35
K11R 132 M8	41	35	132	16	310	257	310	108	12	12	479	519	562	25A	143	134	M32 x 1.5	25 AV	143	134	M32 x 1.5	4L	35
K11R 160 M2	45	41	160	18	374	336	397	114	15	20	571	611	686	63A	184	172	M40 x 1.5	100/63 AV	223	214	M40 x 1.5	4L	35
K11R 160 MX2	45	45	160	18	402	336	402	138	15	20	571	611	686	63A	184	172	M40 x 1.5	100/63 AV	223	214	M40 x 1.5	4L	35
K11R 160 L2	45	45	160	18	402	336	402	138	15	20	609	649	724	63A	184	172	M40 x 1.5	100/63 AV	223	214	M40 x 1.5	4L	35
K11R 160 M4	45	45	160	18	374	336	374	114	15	20	571	611	686	63A	184	172	M40 x 1.5	100/63 AV	223	214	M40 x 1.5	4L	35
K11R 160 L4	45	45	160	18	402	336	402	138	15	20	609	649	724	63A	184	172	M40 x 1.5	100/63 AV	223	214	M40 x 1.5	4L	35
K11R 160 M6	45	41	160	18	374	307	397	114	15	20	559	599	643	63A	184	172	M40 x 1.5	100/63 AV	223	214	M40 x 1.5	4L	35
K11R 160 L6	45	45	160	18	402	336	402	138	15	20	609	649	724	63A	184	172	M40 x 1.5	100/63 AV	223	214	M40 x 1.5	4L	35
K11R 160 M8	45	41	160	18	374	307	397	138	15	20	559	599	643	63A	184	172	M40 x 1.5	100/63 AV	223	214	M40 x 1.5	4L	35
K11R 160 MX8	45	41	160	18	374	307	397	138	15	20	559	599	643	63A	184	172	M40 x 1.5	100/63 AV	223	214	M40 x 1.5	4L	35
K11R 180 M4	51.5	45	180	20	441	369	422	138	15	20	635	675	751	63A	184	172	M40 x 1.5	100/63 AV	223	214	M40 x 1.5	4L	35
K11R 180 L6	51.5	45	180	20	422	369	422	138	15	20	609	649	724	63A	184	172	M40 x 1.5	100/63 AV	223	214	M40 x 1.5	4L	35

^{*)} Terminal box left/right

Three-phase motors with squirrel-cage rotor
Type of explosion protection – Increased safety „e“ („eb“)
Low-noise design with direction-dependent fan

with surface cooling, type of cooling IC 411, degree of protection IP 55
 Size 132 to 160

Type of construction IM B14 [IM 3601]

Flange dimensions, see page 10/6

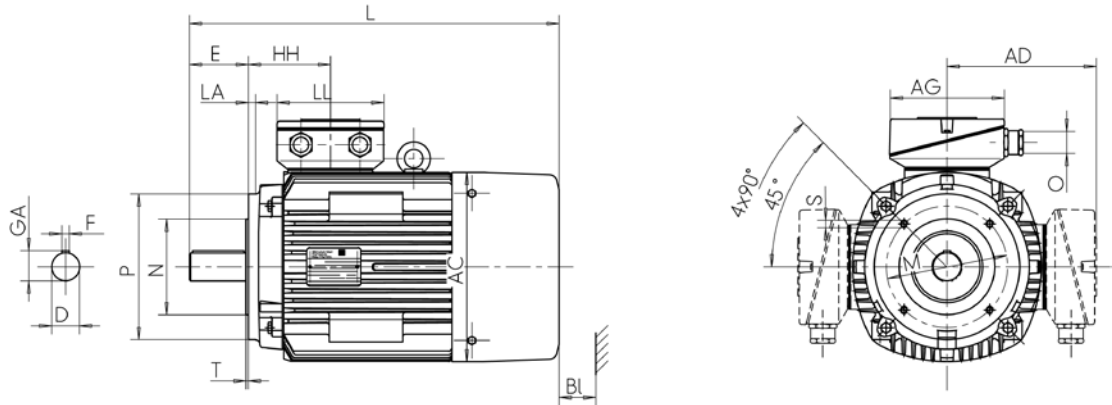

Type designation	Flange size		A	AA	AB	AC	AD	AD	B	BA	BB	C	D	DB ¹⁾	E	F
	small	large	b	n	f	g	g1	VIK g1	a	m	e	w1	d		l	u
	K11R 132 S2G	C160	C200	216	50	256	217	178	178	140	55	180	89	38	M12	80
K11R 132 SX2G	C160	C200	216	50	256	258	178	178	140	47	180	89	38	M12	80	10
K12R 132 SX2G	C160	C200	216	50	256	258	178	178	140	47	180	89	38	M12	80	10
K11R 160 M2G	C250	C300	254	55	296	313	214	237	210	60	257	108	42	M16	110	12
K11R 160 MX2G	C250	C300	254	55	296	313	242	242	210	60	257	108	42	M16	110	12
K11R 160 L2G	C250	C300	254	55	296	313	242	242	254	60	301	108	42	M16	110	12

¹⁾ Centre holes to DIN 332-DS ...

Three-phase motors with squirrel-cage rotor
Type of explosion protection – Increased safety „e“ („eb“)
Low-noise design with direction-dependent fan

with surface cooling, type of cooling IC 411, degree of protection IP 55
 Size 56 to 180

Type of construction IM B34 [IM 2101]

Flange dimensions, see page 10/6

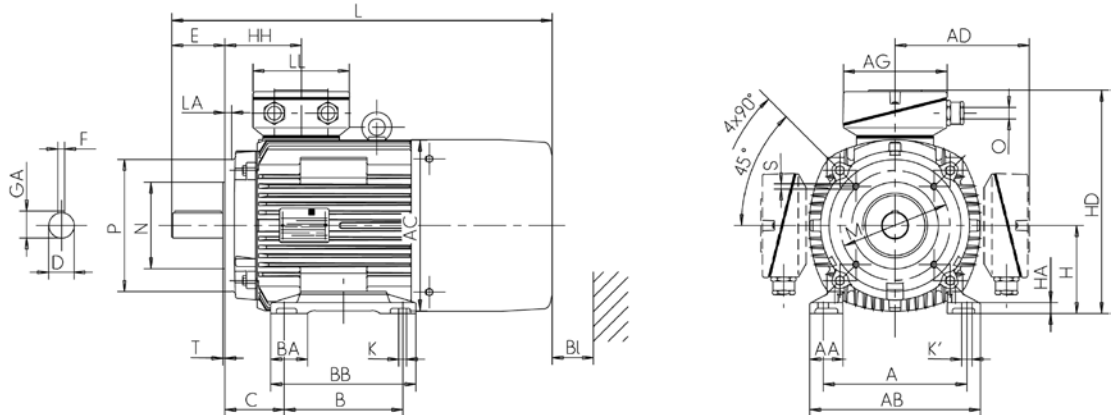

Type designation	GA	H	HA	HD	HD ^{*)}	HD	HH	K	K'	L	L	TB Type	AG	LL	O	TB Type	AG	LL	O	Hole pattern	BI
	t	h	c	p	p	p	A	s	s'	k	k	Ex e IIC Standard	x	z	r	Ex e IIC VIK	x	z	r		BI
K11R 132 S2G	41	132	16	310	257	310	108	12	12	584	624	25A	143	134	M32 x 1.5	25 AV	143	134	M32 x 1.5	4L	35
K11R 132 SX2G	41	132	15	310	279	310	108	12	12	584	624	25A	143	134	M32 x 1.5	25 AV	143	134	M32 x 1.5	4L	35
K12R 132 SX2G	41	132	15	310	279	310	108	12	12	644	684	25A	143	134	M32 x 1.5	25 AV	143	134	M32 x 1.5	4L	35
K11R 160 M2G	45	160	18	374	336	397	114	15	20	699	739	63 A	184	172	M40 x 1.5	100/63 AV	223	214	M40 x 1.5	4L	35
K11R 160 MX2G	45	160	18	402	336	402	138	15	20	699	739	63 A	184	172	M40 x 1.5	100/63 AV	223	214	M40 x 1.5	4L	35
K11R 160 L2G	45	160	18	402	336	402	138	15	20	737	777	63 A	184	172	M40 x 1.5	100/63 AV	223	214	M40 x 1.5	4L	35

^{*)} Terminal box left/right

Three-phase motors with squirrel-cage rotor Type of explosion protection – Increased safety „e“ („eb“)

with surface cooling, type of cooling IC 411, degree of protection IP 55
Size 56 to 250

Type of construction IM B5 [IM 3001], IM V1 [IM 3011]

Flange dimensions, see page 10/6

Type designation	Flange size	AC	AD	D	DA	DB ^{*)}	E	EA	F	FA	GA	GC	H	HH	L
		g	g1	d	d1		l	l1	u	u1	t	t1	h	A	k
KPE0 56 K	A120	109	-	9	9	M3	20	20	3	3	10.2	10.2	56	67	152
KPER 56 G	A120	109	-	9	9	M3	20	20	3	3	10.2	10.2	56	67	177
KPER 63 K, L	A140	109	-	11	11	M4	23	23	4	4	12.5	12.5	63	67	180
KPER 71 K, L	A160	124	-	14	14	M5	30	30	5	5	16	16	71	70	207
KPER 80 K, L	A200	139	-	19	19	M6	40	40	6	6	21.5	21.5	80	76	250
KPER 90 S	A200	157	-	24	22	M8	50	50	8	6	27	24.5	90	79	276
KPER 90 L	A200	157	-	24	22	M8	50	50	8	6	27	24.5	90	79	298
KPER 100 L	A250	177	-	28	24	M10	60	50	8	8	31	27	100	84	332
KPER 100 LX4	A250	196	-	28	28	M10	60	60	8	8	31	31	100	86	358
KPER 112 M2	A250	196	-	28	28	M10	60	60	8	8	31	31	112	86	392
KPER 112 MX2	A250	196	-	28	28	M10	60	60	8	8	31	31	112	86	392
KPER 112 M4	A250	196	-	28	28	M10	60	60	8	8	31	31	112	86	392
KPER 132 S2T	A300	196	-	38	28	M10	80	60	10	8	41	31	132	105	431
KPER 132 S4T	A300	196	-	38	28	M10	80	60	10	8	41	31	132	105	460
K11R 132 S2	A300	217	178	38	32	M12	80	80	10	10	41	35	132	108	459
K11R 132 SX2	A300	258	178	38	38	M12	80	80	10	10	41	35	132	108	459
K12R 132 SX2	A300	258	178	38	38	M12	80	80	10	10	41	35	132	108	530
K11R 132 S4	A300	217	178	38	32	M12	80	80	10	10	41	35	132	108	459
K11R 132 M4	A300	258	199	38	38	M12	80	80	10	10	41	41	132	114	481
K11R 132 M6	A300	217	178	38	32	M12	80	80	10	10	41	35	132	108	479
K11R 132 MX6	A300	258	199	38	38	M12	80	80	10	10	41	41	132	114	481
K11R 132 M8	A300	217	178	38	32	M12	80	80	10	10	41	35	132	108	479
K11R 160 M2	A350	313	214	42	38	M16	110	80	12	10	45	41	160	114	571
K11R 160 MX2	A350	313	242	42	42	M16	110	110	12	12	45	45	160	138	571
K11R 160 L2	A350	313	242	42	42	M16	110	110	12	12	45	45	160	138	609
K11R 160 M4	A350	313	214	42	42	M16	110	110	12	12	45	45	160	114	571
K11R 160 L4	A350	313	242	42	42	M16	110	110	12	12	45	45	160	138	609
K11R 160 M6	A350	258	214	42	38	M16	110	80	12	10	45	41	160	114	559
K11R 160 L6	A350	313	242	42	42	M16	110	110	12	12	45	45	160	138	609
K11R 160 M8	A350	258	214	42	38	M16	110	80	12	10	45	41	160	138	559
K11R 160 MX8	A350	258	214	42	38	M16	110	80	12	10	45	41	160	138	559
K11R 180 M2	A350	351	261	48	48	M16	110	110	14	14	51.5	51.5	180	147	635
K11R 180 M4	A350	351	242	48	42	M16	110	110	14	12	51.5	45	180	138	635
K11R 180 L4	A350	351	261	48	48	M16	110	110	14	14	51.5	51.5	180	147	680
K11R 180 L6	A350	313	242	48	42	M16	110	110	14	12	51.5	45	180	138	609
K11R 200 L2	A400	351	261	55	48	M20	110	110	16	14	59	51.5	200	147	680
K11R 200 LX2	A400	390	300	55	55	M20	110	110	16	16	59	59	200	168	727
K11R 200 L4	A400	351	261	55	48	M20	110	110	16	14	59	51.5	200	147	680
K11R 200 L6	A400	351	261	55	48	M20	110	110	16	14	59	51.5	200	147	680
K11R 200 LX6	A400	351	261	55	48	M20	110	110	16	14	59	51.5	200	147	680
K11R 225 M2	A450	440	300	55	55	M20	110	110	16	16	59	59	225	168	832
K11R 225 S4	A450	440	300	60	55	M20	140	110	18	16	64	59	225	168	862
K11R 225 M4	A450	440	300	60	55	M20	140	110	18	16	64	59	225	168	862
K11R 225 M6	A450	390	300	60	55	M20	140	110	18	16	64	59	225	168	757
K11R 225 S8	A450	390	300	60	55	M20	140	110	18	16	64	59	225	168	757
K11R 250 M2	A550	490	358	60	55	M20	140	110	18	16	64	59	250	177	924
K11R 250 M4	A550	490	358	65	55	M20	140	110	18	16	69	59	250	177	924

^{*)} Centre holes to DIN 332-DS ...

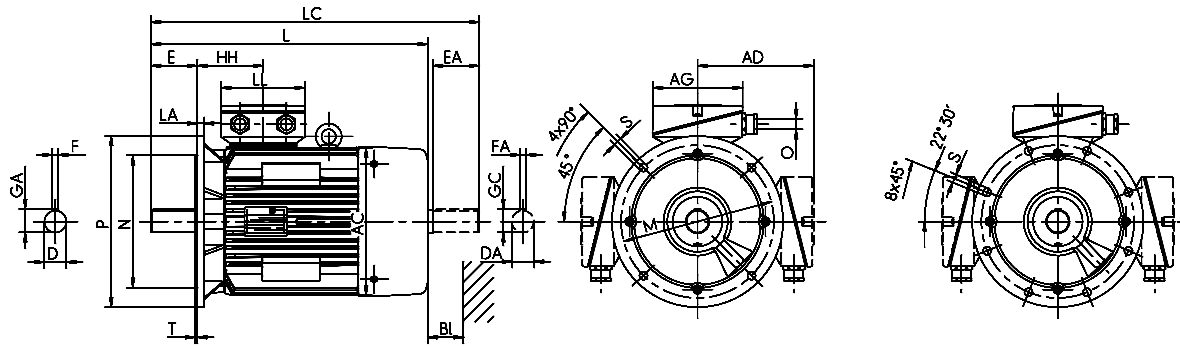

Type designation	L (IM V1)	LC	TB Type Ex e IIC Standard	AG	LL	O	TB Type Ex e IIC VIK	AG	LL	O	Hole pattern	BI
	k (IM V1)	k1										
KPEO 56 K	152	175	KA 05-13	104	112	M20 x 1.5	KA 05-13	104	112	M20 x 1.5	4L	-
KPER 56 G	198	199	KA 05-13	104	112	M20 x 1.5	KA 05-13	104	112	M20 x 1.5	4L	14
KPER 63 K, L	198	205	KA 05-13	104	112	M20 x 1.5	KA 05-13	104	112	M20 x 1.5	4L	14
KPER 71 K, L	225	239	KA 05-13	104	112	M20 x 1.5	KA 05-13	104	112	M20 x 1.5	4L	14
KPER 80 K, L	268	293	KA 05-13	104	112	M20 x 1.5	KA 05-13	104	112	M20 x 1.5	4L	16
KPER 90 S	294	330	KA 05-13	104	112	M25 x 1.5	KA 05-13	104	112	M25 x 1.5	4L	16
KPER 90 L	316	352	KA 05-13	104	112	M25 x 1.5	KA 05-13	104	112	M25 x 1.5	4L	16
KPER 100 L	350	386	KA 05-13	104	112	M25 x 1.5	KA 05-13	104	112	M25 x 1.5	4L	18
KPER 100 LX4	376	425	KA 05-13	104	112	M25 x 1.5	KA 05-13	104	112	M25 x 1.5	4L	20
KPER 112 M2	376	425	KA 05-13	104	112	M25 x 1.5	KA 05-13	104	112	M25 x 1.5	4L	20
KPER 112 MX2	376	459	KA 05-13	104	112	M25 x 1.5	KA 05-13	104	112	M25 x 1.5	4L	20
KPER 112 M4	376	459	KA 05-13	104	112	M25 x 1.5	KA 05-13	104	112	M25 x 1.5	4L	20
KPER 132 S2T	457	498	KA 05-13	104	112	M32 x 1.5	KA 05-13	104	112	M32 x 1.5	4L	20
KPER 132 S4T	480	528	KA 05-13	104	112	M32 x 1.5	KA 05-13	104	112	M32 x 1.5	4L	20
K11R 132 S2	499	542	25 A	143	134	M32 x 1.5	25 AV	143	134	M32 x 1.5	4L	35
K11R 132 SX2	499	542	25 A	143	134	M32 x 1.5	25 AV	143	134	M32 x 1.5	4L	35
K12R 132 SX2	570	613	25 A	143	134	M32 x 1.5	25 AV	143	134	M32 x 1.5	4L	35
K11R 132 S4	499	542	25 A	143	134	M32 x 1.5	25 AV	143	134	M32 x 1.5	4L	35
K11R 132 M4	521	565	25 A	143	134	M32 x 1.5	25 AV	143	134	M32 x 1.5	4L	35
K11R 132 M6	519	562	25 A	143	134	M32 x 1.5	25 AV	143	134	M32 x 1.5	4L	35
K11R 132 MX6	521	565	25 A	143	134	M32 x 1.5	25 AV	143	134	M32 x 1.5	4L	35
K11R 132 M8	519	562	25 A	143	134	M32 x 1.5	25 AV	143	134	M32 x 1.5	4L	35
K11R 160 M2	611	686	63 A	184	172	M40 x 1.5	100/63 AV	223	214	M40 x 1.5	4L	35
K11R 160 MX2	611	686	63 A	184	172	M40 x 1.5	100/63 AV	223	214	M40 x 1.5	4L	35
K11R 160 L2	649	724	63 A	184	172	M40 x 1.5	100/63 AV	223	214	M40 x 1.5	4L	35
K11R 160 M4	611	686	63 A	184	172	M40 x 1.5	100/63 AV	223	214	M40 x 1.5	4L	35
K11R 160 L4	649	724	63 A	184	172	M40 x 1.5	100/63 AV	223	214	M40 x 1.5	4L	35
K11R 160 M6	599	643	63 A	184	172	M40 x 1.5	100/63 AV	223	214	M40 x 1.5	4L	35
K11R 160 L6	649	724	63 A	184	172	M40 x 1.5	100/63 AV	223	214	M40 x 1.5	4L	35
K11R 160 M8	599	643	63 A	184	172	M40 x 1.5	100/63 AV	223	214	M40 x 1.5	4L	35
K11R 160 MX8	599	643	63 A	184	172	M40 x 1.5	100/63 AV	223	214	M40 x 1.5	4L	35
K11R 180 M2	675	751	63 A	184	172	M40 x 1.5	100/63 AV	223	214	M40 x 1.5	4L	35
K11R 180 M4	675	751	63 A	184	172	M40 x 1.5	100/63 AV	223	214	M40 x 1.5	4L	35
K11R 180 L4	720	796	63 A	184	172	M40 x 1.5	100/63 AV	223	214	M40 x 1.5	4L	35
K11R 180 L6	649	724	63 A	184	172	M40 x 1.5	100/63 AV	223	214	M40 x 1.5	4L	35
K11R 200 L2	720	796	63/100 A	223	214	M50 x 1.5	100/63 AV	223	214	M50 x 1.5	4L	35
K11R 200 LX2	772	851	100 A	222	214	M50 x 1.5	200 A-SB	335	270	M50 x 1.5	4L	35
K11R 200 L4	720	796	100 A	222	214	M50 x 1.5	100/63 AV	223	214	M50 x 1.5	4L	35
K11R 200 L6	720	796	63 A	184	172	M40 x 1.5	100/63 AV	223	214	M40 x 1.5	4L	35
K11R 200 LX6	720	796	63/100 A	223	214	M50 x 1.5	100/63 AV	223	214	M50 x 1.5	4L	35
K11R 225 M2	917	947	100 A	222	214	M50 x 1.5	200 A-SB	335	270	M50 x 1.5	8L	45
K11R 225 S4	947	977	100 A	222	214	M50 x 1.5	200 A-SB	335	270	M50 x 1.5	8L	45
K11R 225 M4	947	977	100 A	222	214	M50 x 1.5	200 A-SB	335	270	M50 x 1.5	8L	45
K11R 225 M6	842	881	100 A	222	214	M50 x 1.5	200 A-SB	335	270	M50 x 1.5	8L	40
K11R 225 S8	802	881	100 A	222	214	M50 x 1.5	200 A-SB	335	270	M50 x 1.5	8L	40
K11R 250 M2	1010	1042	200 A	290	252	M63 x 1.5	200 A-SB	335	270	M63 x 1.5	8L	50
K11R 250 M4	1010	1042	200 A	290	252	M63 x 1.5	200 A-SB	335	270	M63 x 1.5	8L	50

Three-phase motors with squirrel-cage rotor
Type of explosion protection – Increased safety „e“ („eb“)
Low-noise design with direction-dependent fan

with surface cooling, type of cooling IC 411, degree of protection IP 55
 Size 132 to 250

Type of construction IM B5 [IM 3001], IM V1 [IM 3011]
 Flange dimensions, see page 10/6

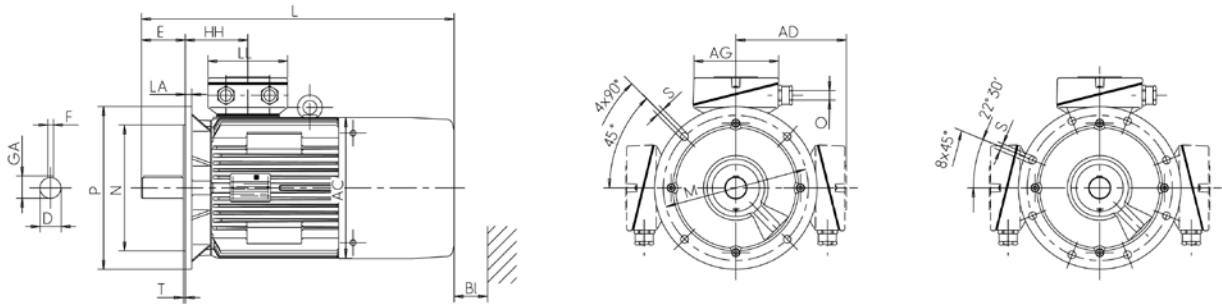

Type designation	Flange size	AC g	AD g1	D d	DA d1	DB ¹⁾	E l	F u	GA t	H h	HH A	L k
K11R 132 S2G	A300	217	178	38	32	M12	80	10	41	132	108	584
K11R 132 SX2G	A300	258	178	38	38	M12	80	10	41	132	108	584
K12R 132 SX2G	A300	258	178	38	38	M12	80	10	41	132	108	644
K11R 160 M2G	A350	313	214	42	38	M16	110	12	45	160	114	699
K11R 160 MX2G	A350	313	242	42	42	M16	110	12	45	160	138	699
K11R 160 L2G	A350	313	242	42	42	M16	110	12	45	160	138	737
K11R 180 M2G	A350	351	261	48	48	M16	110	14	51.5	180	147	782
K11R 200 L2G	A400	351	261	55	48	M20	110	16	59	200	147	827
K11R 200 LX2G	A400	390	300	55	55	M20	110	16	59	200	168	790
K11R 225 M2G	A450	440	300	55	55	M20	110	16	59	225	168	897
K11R 250 M2G	A550	490	358	60	55	M20	140	18	64	250	177	1004

Type designation	L (IM V1) k (IM V1)	TB Type Ex e IIC Standard	AG	LL	O	TB Type Ex e IIC VIK	AG	LL	O	Hole pattern	BI
K11R 132 S2G	624	25 A	143	134	M32 x 1.5	25 AV	143	134	M32 x 1.5	4L	35
K11R 132 SX2G	624	25 A	143	134	M32 x 1.5	25 AV	143	134	M32 x 1.5	4L	35
K12R 132 SX2G	684	25 A	143	134	M32 x 1.5	25 AV	143	134	M32 x 1.5	4L	35
K11R 160 M2G	739	63 A	184	172	M40 x 1.5	100/63 AV	223	214	M32 x 1.5	4L	35
K11R 160 MX2G	739	63 A	184	172	M40 x 1.5	100/63 AV	223	214	M40 x 1.5	4L	35
K11R 160 L2G	777	63 A	184	172	M40 x 1.5	100/63 AV	223	214	M40 x 1.5	4L	35
K11R 180 M2G	822	63 A	184	172	M40 x 1.5	100/63 AV	223	214	M40 x 1.5	4L	35
K11R 200 L2G	867	63/100 A	223	214	M50 x 1.5	100/63 AV	223	214	M50 x 1.5	4L	35
K11R 200 LX2G	835	100 A	222	214	M50 x 1.5	200 A-SB	335	270	M50 x 1.5	4L	35
K11R 225 M2G	952	100 A	222	214	M50 x 1.5	200 A-SB	335	270	M50 x 1.5	8L	45
K11R 250 M2G	1090	200 A	290	252	M63 x 1.5	200 A-SB	335	270	M63 x 1.5	8L	50

¹⁾ Centre holes to DIN 332-DS ...

Three-phase motors with squirrel-cage rotor Type of explosion protection – Increased safety „e“ („eb“)

with surface cooling, type of cooling IC 411, degree of protection IP 55
Size 280 to 355

Type of construction IM B5 [IM 3001], IM V1 [IM 3011]

Flange dimensions, see page 10/6

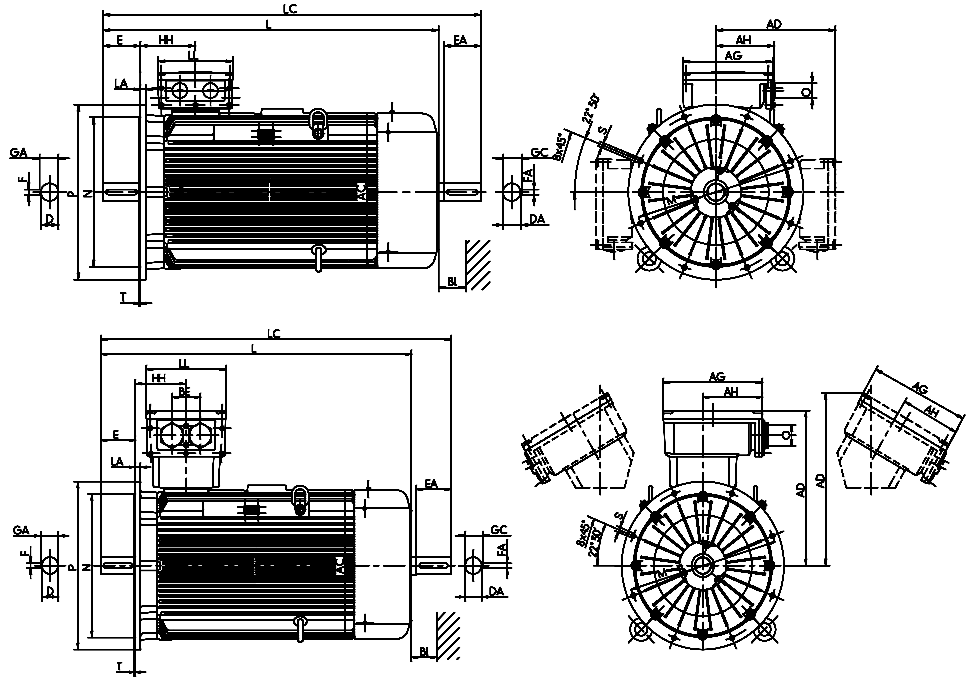

Type designation	Flange size	AC	AD	D	DA	DB ¹⁾	E	EA	F	FA	GA	GC	H	HH	L	L	LC	TB Type	AG	LL	O	Hole pattern	BI
		g	g1	d	d1	l	l1	u	u1	t	t1	h	A	k	k1								
K11R 280 S2	A550	550	386	65	65	M20	140	140	18	18	69	69	280	206	1050	1149	1218	400 A-SB	415	340	M63 x 1.5	8L	55
K11R 280 M2	A550	550	386	65	65	M20	140	140	18	18	69	69	280	206	1105	1204	1273	400 A-SB	415	340	M63 x 1.5	8L	55
K11R 280 S4	A550	550	386	75	65	M20	140	140	20	18	79.5	69	280	206	1050	1149	1218	400 A-SB	415	340	M63 x 1.5	8L	55
K11R 280 M4	A550	550	386	75	65	M20	140	140	20	18	79.5	69	280	206	1105	1204	1273	400 A-SB	415	340	M63 x 1.5	8L	55
K11R 280 S6	A660	550	386	80	70	M20	140	140	20	18	79.5	69	280	206	1080	1179	1248	400 A-SB	415	340	M63 x 1.5	8L	55
K11R 315 S2	A660	550	416	65	65	M20	140	140	18	18	69	69	315	211	1105	1204	1273	400 A-SB	415	340	M63 x 1.5	8L	55
K11R 315 M2	A660	550	416	65	65	M20	140	140	18	18	69	69	315	211	1185	1284	1353	400 A-SB	415	340	M63 x 1.5	8L	55
K11R 315 MX2	A660	550	416	65	65	M20	140	140	18	18	69	69	315	211	1185	1284	1353	400 A-SB	415	340	M63 x 1.5	8L	55
K11R 315 MY2	A660	610	498	65	65	M20	140	140	18	18	69	69	315	230	1270	1385	1448	400 A-SB	415	340	M63 x 1.5	8L	55
K11R 315 L2	A660	610	416	65	65	M20	140	140	18	18	69	69	315	211	1390	1505	1543	630 A	496	390	M75 x 1.5	8L	55
K11R 315 LX2	A660	610	416	65	65	M20	140	140	18	18	69	69	315	211	1510	1625	1688	630 A	496	390	M75 x 1.5	8L	55
K11R 315 S4	A660	550	416	80	70	M20	170	140	22	20	85	74.5	315	211	1135	1234	1303	400 A-SB	415	340	M63 x 1.5	8L	55
K11R 315 M4	A660	550	498	80	70	M20	170	140	22	20	85	74.5	315	230	1215	1314	1383	400 A-SB	415	340	M63 x 1.5	8L	55
K11R 315 MX4	A660	550	498	80	70	M20	170	140	22	20	85	74.5	315	230	1215	1314	1383	400 A-SB	415	340	M63 x 1.5	8L	55
K11R 315 MY4	A660	610	416	80	70	M20	170	140	22	20	85	74.5	315	211	1300	1415	1478	400 A-SB	415	340	M63 x 1.5	8L	55
K11R 315 L4	A660	610	498	80	70	M20	170	140	22	20	85	74.5	315	230	1420	1535	1598	400 A-SB	415	340	M63 x 1.5	8L	55
K11R 315 LX4	A660	610	481	80	70	M20	170	140	22	20	85	74.5	315	230	1540	1655	1723	630 A	496	390	M75 x 1.5	8L	55
K11R 315 MX6	A660	550	481	80	70	M20	170	140	22	20	85	74.5	315	230	1135	1234	1303	400 A-SB	415	340	M63 x 1.5	8L	55
K11R 315 LX6	A660	610	498	80	70	M20	170	140	22	20	85	74.5	315	230	1420	1535	1598	630 A	496	390	M75 x 1.5	8L	55
K12R 355 M2G	A800	715	-	80	80	M20	170	-	22	-	85	-	355	250	1530	1651	-	630 A	496	390	M75 x 1.5	8L	60
K12R 355 MX2G	A800	715	-	80	80	M20	170	-	22	-	85	-	355	327	1650	1771	-	630 A	496	390	M75 x 1.5	8L	60
K12R 355 L2G	A800	715	-	80	80	M20	170	-	22	-	85	-	355	327	1650	1771	-	630 A	496	390	M75 x 1.5	8L	60
K12R 355 M4	A800	715	-	100	80	M24	210	170	28	22	106	85	355	250	1570	1691	1755	630 A	496	390	M75 x 1.5	8L	60
K12R 355 MX4	A800	715	-	100	80	M24	210	170	28	22	106	85	355	327	1690	1811	1875	630 A	496	390	M75 x 1.5	8L	60
K12R 355 L4	A800	715	-	100	80	M24	210	170	28	22	106	85	355	327	1690	1811	1875	630 A	496	390	M75 x 1.5	8L	60

¹⁾ Centre holes to DIN 332-DS ...

**Three-phase motors with squirrel-cage rotor,
Type of explosion protection – Increased safety „e“ („eb“)
Low-noise design with direction-dependent fan**

with surface cooling, type of cooling IC 411, degree of protection IP 55
Size 132 to 315

Type of construction IM B5 [IM 3001], IM V1 [IM 3011]

Flange dimensions, see page 10/6

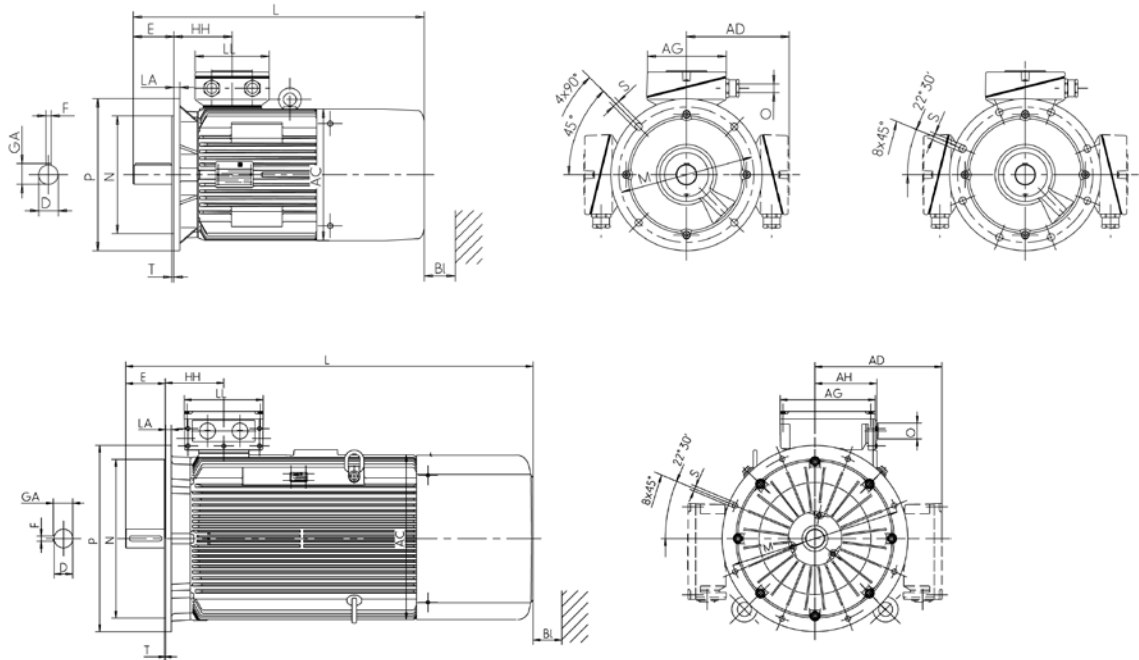

Type designation	Flange size	AC	AD	D	DA	DB ¹⁾	E	EA	F	FA	GA	GC	H	HH	L	L (IM V1)	LC	TB Type	AG	LL	O	Hole pattern	BI
		g	g1	d	d1		l	l1	u	u1	t	t1	h	A	k	(IM V1)	k1	Ex e IIC Standard					
K11R 132 S2G	A300	217	178	38	32	M12	80	80	10	10	41	35	132	108	584	624	542	25 A	143	134	M32 x 1.5	4L	35
K11R 132 SX2G	A300	258	178	38	38	M12	80	80	10	10	41	35	132	108	584	624	542	25 A	143	134	M32 x 1.5	4L	35
K12R 132 SX2G	A300	258	178	38	38	M12	80	80	10	10	41	35	132	108	644	684	613	25 A	143	134	M32 x 1.5	4L	35
K11R 160 M2G	A350	313	214	42	38	M16	110	80	12	10	45	41	160	114	699	739	686	63 A	184	172	M40 x 1.5	4L	35
K11R 160 MX2G	A350	313	242	42	42	M16	110	110	12	12	45	45	160	138	699	739	686	63 A	184	172	M40 x 1.5	4L	35
K11R 160 L2G	A350	313	242	42	42	M16	110	110	12	12	45	45	160	138	737	777	724	63 A	184	172	M40 x 1.5	4L	35
K11R 180 M2G	A350	351	261	48	48	M16	110	110	14	14	51.5	51.5	180	147	782	822	751	63 A	184	172	M40 x 1.5	4L	35
K11R 200 L2G	A400	351	261	55	48	M20	110	110	16	14	59	51.5	200	147	827	867	796	63/100 A	223	214	M50 x 1.5	4L	35
K11R 200 LX2G	A400	390	300	55	55	M20	110	110	16	16	59	59	200	168	790	835	851	100 A	222	214	M50 x 1.5	4L	35
K11R 225 M2G	A450	440	300	55	55	M20	110	110	16	16	59	59	225	168	897	952	947	100 A	222	214	M50 x 1.5	8L	45
K11R 250 M2G	A550	490	358	60	55	M20	140	110	18	16	64	59	250	177	1004	1090	1042	200 A	290	252	M63 x 1.5	8L	50
K11R 280 S2G	A550	550	386	65	65	M20	140	140	18	18	69	69	280	206	1135	1234	1218	400 A-SB	415	340	M63 x 1.5	8L	55
K11R 280 M2G	A550	550	386	65	65	M20	140	140	18	18	69	69	280	206	1190	1289	1273	400 A-SB	415	340	M63 x 1.5	8L	55
K11R 315 S2G	A660	550	416	65	65	M20	140	140	18	18	69	69	315	211	1190	1289	1273	400 A-SB	415	340	M63 x 1.5	8L	55
K11R 315 M2G	A660	550	416	65	65	M20	140	140	18	18	69	69	315	211	1270	1369	1353	400 A-SB	415	340	M63 x 1.5	8L	55
K11R 315 MX2G	A660	550	416	65	65	M20	140	140	18	18	69	69	315	211	-	-	1353	400 A-SB	415	340	M63 x 1.5	8L	55
K11R 315 MY2G	A660	610	498	65	65	M20	140	140	18	18	69	69	315	230	1390	1505	1448	400 A-SB	415	340	M63 x 1.5	8L	55
K11R 315 L2G	A660	610	498	65	65	M20	140	140	18	18	69	69	315	230	1510	1625	1543	630 A	496	390	M75 x 1.5	8L	55
K11R 315 LX2G	A660	610	481	65	65	M20	140	140	18	18	69	69	315	230	1510	1625	1688	630 A	496	390	M75 x 1.5	8L	55

¹⁾ Centre holes to DIN 332-DS ...

Three-phase motors with squirrel-cage rotor Type of explosion protection – Increased safety „e“ („eb“)

with surface cooling, type of cooling IC 411, degree of protection IP 55
Size 355

Type of construction IM B3 [IM 1001]

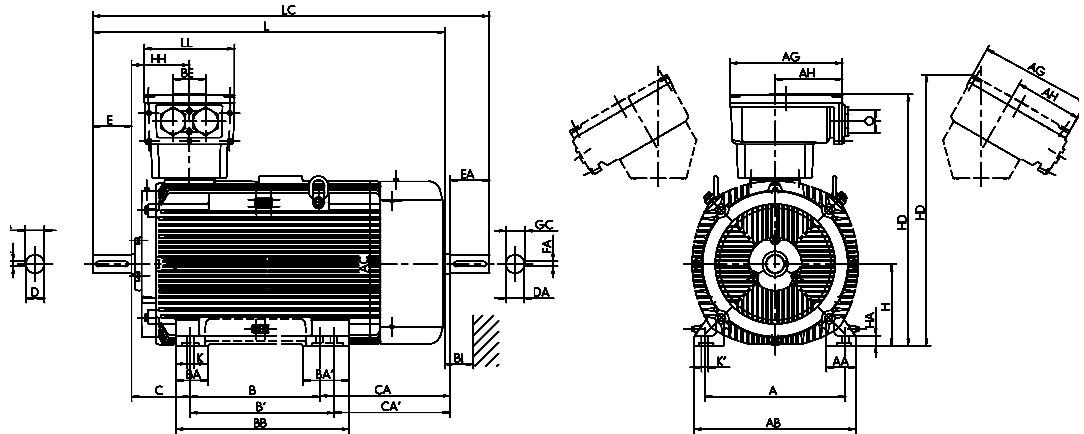

Type of construction IM B35 [IM 2001]

Flange dimensions, see page 10/6

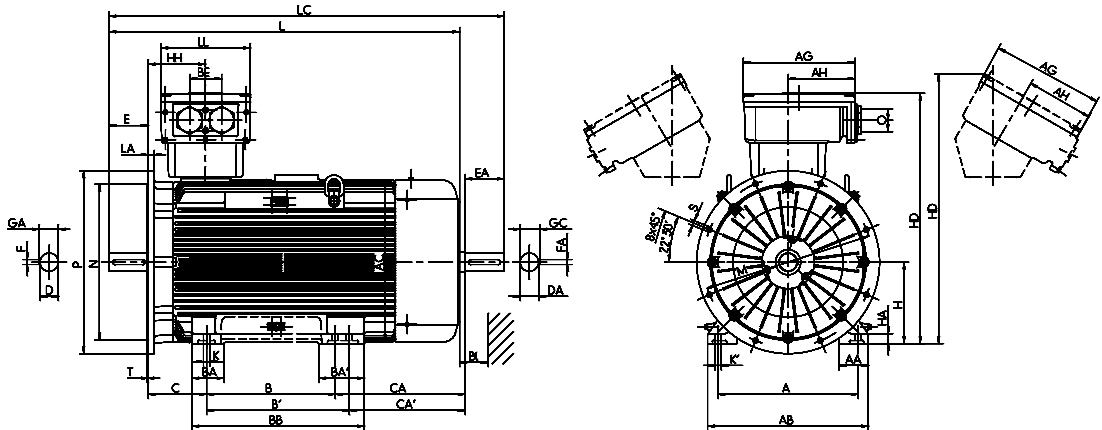

Type designation	Flange size	A	AA	AB	AC	B	B'	BA	BA'	BB	C	CA	D	DA	DB ^{*)}	E	EA	F	FA
		b	n	f	g	a	a	m	m1	e	w1	w2	d	d1		l	l1	u	u1
K12R 355 M4, 6, 8	A800	610	130	700	715	560	630	140	200	750	254	561	100	80	M24	210	170	28	22
K12R 355 MX4, 6, 8	A800	610	130	700	715	560	630	140	200	750	254	681	100	80	M24	210	170	28	22
K12R 355 L4, 6, 8	A800	610	130	700	715	560	630	140	200	750	254	611	100	80	M24	210	170	28	22

	GA	GC	H	HA	HD	HD ^{**)}	HH	K	K'	L	L (IM V1)	LC	TB Type Ex e IIC Standard/VIK	AG	LL	AH	BE	O	BI
	t	t1	h	c	p	p	A	s	s'	k	k (IM V1)	k1		x	z	-	-	r	BI
K12R 355 M4, 6, 8	106	85	355	44	1172	-	250	28	35	1570	1691	1755	630 A	496	390	301	140	M75 x 1.5	60
K12R 355 MX4, 6, 8	106	85	355	44	1179	-	327	28	35	1690	1811	1875	630 A	496	390	301	140	M75 x 1.5	60
K12R 355 L4, 6, 8	106	85	355	44	1179	-	327	28	35	1690	1811	1875	630 A	496	390	301	140	M75 x 1.5	60

^{*)} Centre holes to DIN 332-DS ...

^{**)} Terminal box left/right

Three-phase motors with squirrel-cage rotor
Type of explosion protection – Increased safety „e“ („eb“)
Low-noise design with direction-dependent fan

with surface cooling, type of cooling IC 411, degree of protection IP 55
 Size 355

Type of construction IM B3 [IM 1001]

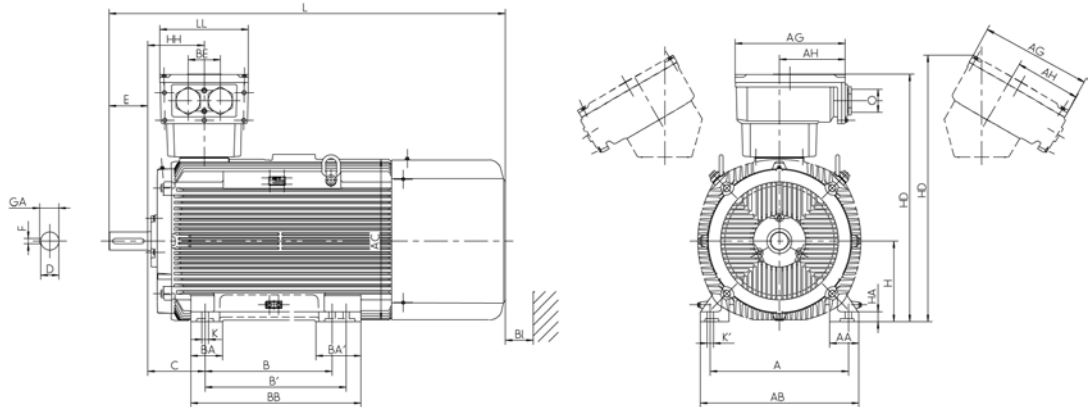

Type of construction IM B35 [IM 2001]

Flange dimensions, see page 10/6

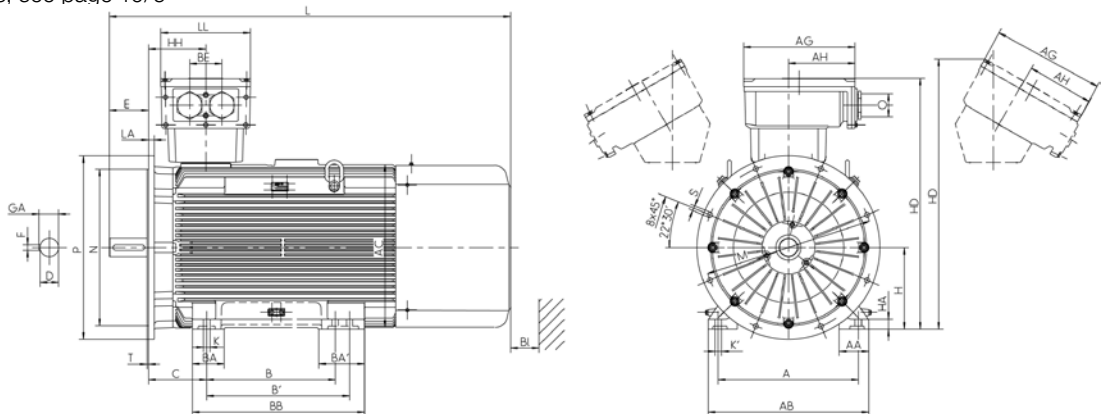

Type designation	Flange size	A	AA	AB	AC	B	B'	BA	BA'	BB	C	CA	D	DA	DB ¹⁾	E	F
		b	n	f	g	a	a	m	m1	e	w1	w2	d	d1		l	u
K12R 355 M2G	A800	610	130	700	715	560	-	140	200	750	254	561	80	80	M20	170	22
K12R 355 MX2G	A800	610	130	700	715	560	630	140	200	750	254	681	80	80	M20	170	22
K12R 355 L2G	A800	610	130	700	715	560	630	140	200	750	254	611	80	80	M20	170	22

	GA	H	HA	HD	HD ²⁾	HH	K	K'	L	L (IM V1)	TB Type	AG	LL	AH	O
	t	h	c	p	p	A	s	s'	k	k (IM V1)	Ex e IIC	x	z	-	r
K12R 355 M2G	85	355	44	1172	-	250	28	35	1530	1651	630 A	496	390	301	M75 x 1.5
K12R 355 MX2G	85	355	44	1172	-	327	28	35	1650	1771	630 A	496	390	301	M75 x 1.5
K12R 355 L2G	85	355	44	1179	-	327	28	35	1650	1771	630 A	496	390	301	M75 x 1.5

¹⁾ Centre holes to DIN 332-DS ...
²⁾ Terminal box left/right

Three-phase motors with squirrel-cage rotor Type of explosion protection – Increased safety „e“ („eb“)

with surface cooling, type of cooling IC 411, degree of protection IP 55
Size 355

Type of construction IM B5 [IM 3001], IM V1 [IM 3011]

Flange dimensions, see page 10/6

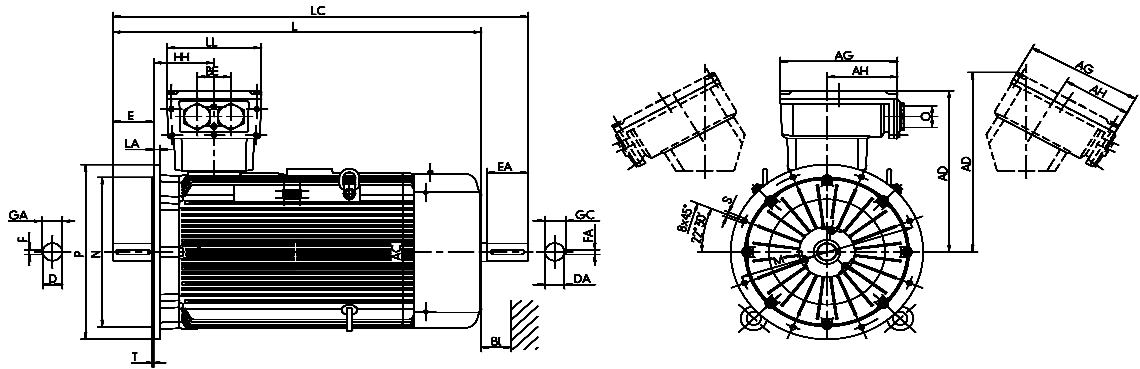

Type designation	Flange size	AC	AD	AD ^{*)}	D	DA	DB ^{*)}	E	EA	F	FA	GA	GC	H	HH	L	L	LC	TB Type	AG	LL	AH	BE	O	BI
		g	g1	g1	d	d1		l	l1	u	u1	t	t1	h	A	K	k	K1	Ex e IIC Standard/VIK	x	z	-	-	r	BI
K12R 355 M4, 6, 8	A800	715	736	736	100	80	M24	210	170	28	22	106	85	355	250	1570	1691	1755	630 A	496	390	301	140	M75 x 1.5	60
K12R 355 MX4, 6, 8	A800	715	736	736	100	80	M24	210	170	28	22	106	85	355	327	1690	1811	1875	630 A	496	390	301	140	M75 x 1.5	60
K12R 355 L4, 6, 8	A800	715	736	736	100	80	M24	210	170	28	22	106	85	355	327	1690	1811	1875	630 A	496	390	301	140	M75 x 1.5	60

^{*)} Centre holes to DIN 332-DS ...

^{**)} Terminal box left/right

Three-phase motors with squirrel-cage rotor Type of explosion protection – Increased safety „e“ („eb“) Low-noise design with direction-dependent fan

with surface cooling, type of cooling IC 411, degree of protection IP 55
Size 355

Type of construction IM B5 [IM 3001], IM V1 [IM 3011]

Flange dimensions, see page 10/6

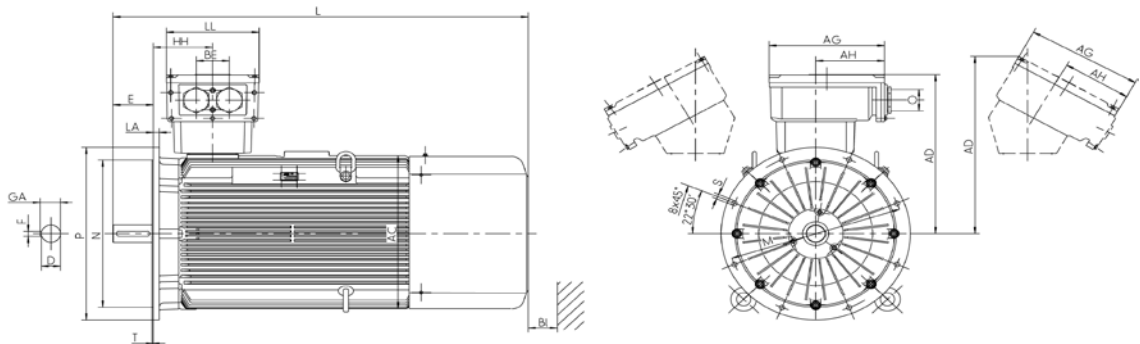

Type designation	Flange size	AC	AD	AD ^{*)}	D	DA	DB ^{*)}	E	EA	F	FA	GA	GC	H	HH	L	L	LC	TB Type	AG	LL	AH	BE	O	BI
		g	g1	g1	d	d1		l	l1	u	u1	t	t1	h	A	K	k	K1	Ex e IIC Standard/VIK	x	z	-	-	r	BI
K12R 355 M2G	A800	715	736	736	80	80	M20	170	-	22	-	85	-	355	250	1530	1651	-	630 A	496	390	301	140	M75 x 1.5	60
K12R 355 MX2G	A800	715	729	729	80	80	M20	170	-	22	-	85	-	355	327	1650	1771	-	630 A	496	390	301	140	M75 x 1.5	60
K12R 355 L2G	A800	715	729	729	80	80	M20	170	-	22	-	85	-	355	327	1650	1771	-	630 A	496	390	301	140	M75 x 1.5	60

^{*)} Centre holes to DIN 332-DS ...

^{**)} Terminal box left/right

Overview of technical data

The most important technical data are summarised in the following table.
Further information can be taken from the catalogue section "Introduction" (Chapter 1).

Product group	Squirrel-cage rotor, IEC/DIN
Explosion protection type	Flameproof enclosure „d/de“ („db/db eb“)
Rated output	Ex d/de (Ex db/db eb) (IE.) – K8.R, 0.12 to 730 kW
Sizes	Ex d/de (Ex db/db eb) (IE.) – K8.R, 63 to 450
Housing material	Grey cast iron
Rated torque	0.6 Nm to 5770 Nm
Efficiency classification/ efficiency determination	IEC/EN 60034-30-1 / IEC/EN 60034-2-1, ≤ 1 kW direct measurement, > 1 kW residual loss method
Method of connection	Single-speed motors are designed in star-delta configuration as standard.
Stator winding insulation	Thermal class 155, optional 155 [F(B)], 180 to IEC/EN 60034-1
Degree of protection	IP 55 to IEC/EN 60034-5
Type of cooling	IC 411, IC 416, IC 71W (IC 31W) to IEC/EN 60034-6
Coolant temperature/ installation altitude	Standard -20 °C to +40 °C, Deviating coolant temperatures upon request Altitude 1000 m above sea level
Rated voltage	Standard voltages to EN 60038 50 Hz: 230 V, 400 V, 500 V, 690 V, 60 Hz: 275 V, 460 V, 480 V, 600 V
Duty types	Continuous duty S1, converter-fed operation S9
Types of construction	IM B3, IM B35, IM B5 and derived types to IEC/EN 60034-7
Paint finish	Normal finish "Moderate", colour RAL 7031, blue-grey Special finish "Worldwide", colour RAL 7031, blue-grey
Vibration severity grade	Grade "A" as standard for machines with no special vibration requirements
Shaft ends	to DIN 748 (IEC 60072), balanced with half-key
Limit speeds	Please refer to the section of "Limit speeds" in catalogue section "Motors for converter-fed operation", Chapter 4.
Bearing design	Please refer to the tables of bearing design data.
Motor mass	Please refer to the technical selection lists.
Terminal boxes	Please refer to the section "Terminal boxes".
Documentation	An operating and maintenance manual, a terminal plan and a safety data sheet are supplied with each motor.
Tolerances	Please refer to the section "Tolerances" in catalogue section "Introduction", Chapter 1.
Options	Please refer to the section "Overview of modifications" in catalogue section "Introduction", Chapter 1.

Motor selection data

Three-phase motors with squirrel-cage rotor, Premium Efficiency IE3
Type of explosion protection – Flameproof enclosure „d/de“ („db/db eb“)
for operation in Zone 1 according to EN 60079-1

II 2G Ex d/de IIC T4 Gb

for rated voltage, temperature class T4
 with surface cooling, duty type S1, continuous duty
 thermal class F, degree of protection IP 55, 50 Hz

Motor selection data											Design point 400 V, 50 Hz	
Type	P _B	M _B	n _B	η _B	cosφ _B	I _B	I _k /I _B	M _k /M _B	M _k /M _B	ATEX no.	J	m
	kW	Nm	rpm	%	-	A	-	-	-		kgm ²	kg
Synchronous speed 3000 rpm – 2-pole version												
Efficiency according to manufacturer standard												
K82R 63 M2 Ex de IIC T4	0.18	0.6	2905	66	0.67	0.59	6.8	4.6	6.5	PTB 09 ATEX 1017 X	0.00028	16
K82R 63 MX2 Ex de IIC T4	0.25	0.8	2860	70	0.75	0.69	5.8	3.4	4.7	PTB 09 ATEX 1017 X	0.00028	16
K82R 71 M2 Ex de IIC T4	0.37	1.3	2800	71.5	0.84	0.89	5.2	2.7	3.5	PTB 09 ATEX 1017 X	0.00028	16
K82R 71 MX2 Ex de IIC T4	0.55	1.9	2810	72	0.82	1.34	5.5	2.8	3.6	PTB 09 ATEX 1017 X	0.00039	17
Efficiency according to IEC/EN 60034-30-1												
IE3-K82R 80 M2 Ex de IIC T4	0.75	2.48	2890	IE3- 82.8	0.87	1.5	6.6	3	3.6	PTB 16 ATEX 1002 X	0.0013	31
IE3-K82R 80 MX2 Ex de IIC T4	1.1	3.64	2885	IE3- 83.7	0.87	2.2	6.5	2.9	3.5	PTB 16 ATEX 1002 X	0.0018	35
IE3-K82R 90 S2 Ex de IIC T4	1.5	4.95	2895	IE3- 84.7	0.88	2.9	6.8	3	3.5	PTB 16 ATEX 1002 X	0.0029	45
IE3-K82R 90 L2 Ex de IIC T4	2.2	7.2	2900	IE3- 86.4	0.88	4.2	6.9	3	3.6	PTB 16 ATEX 1002 X	0.0039	48
IE3-K82R 100 L2 Ex de IIC T4	3	9.8	2910	IE3- 88.1	0.88	5.6	6.9	2.5	2.9	PTB 16 ATEX 1003 X	0.0051	53
IE3-K82R 112 M2 Ex de IIC T4	4	13	2930	IE3- 88.4	0.87	7.5	6.9	2.8	3.6	PTB 16 ATEX 1003 X	0.0089	95
IE3-K82R 132 S2 Ex de IIC T4	5.5	18	2925	IE3- 89.5	0.89	10	7	2.5	3.3	PTB 16 ATEX 1004 X	0.0125	103
IE3-K82R 132 SX2 Ex de IIC T4	7.5	24.4	2930	IE3- 90.3	0.89	13.5	7.1	2.7	3.5	PTB 16 ATEX 1004 X	0.0177	115
K82R 160 M2 Ex de IIC T4 Y3	11	35.7	2940	IE3- 91.3	0.87	20	7.3	3	3.6	PTB 09 ATEX 1018 X	0.032	163
K82R 160 MX2 Ex de IIC T4 Y3	15	48.7	2940	IE3- 92	0.9	26	7.2	2.8	3.2	PTB 09 ATEX 1018 X	0.043	173
K82R 160 L2 Ex de IIC T4 Y3	18.5	60	2940	IE3- 92.5	0.91	31.5	7.2	2.7	3.1	PTB 09 ATEX 1018 X	0.052	188
K82R 180 M2 Ex de IIC T4 Y3	22	71	2945	IE3- 92.9	0.91	37.5	7.5	2.6	3.2	PTB 09 ATEX 1018 X	0.075	196
K82R 200 L2 Ex de IIC T4 Y3	30	97	2955	IE3- 93.5	0.9	51	7.5	2.7	3.1	PTB 09 ATEX 1019 X	0.13	254
K82R 200 LX2 Ex de IIC T4 Y3	37	120	2955	IE3- 93.8	0.9	63	7.6	2.8	3.2	PTB 09 ATEX 1020 X	0.16	278
K82R 225 M2 Ex de IIC T4 Y3	45	145	2960	IE3- 94.2	0.9	77	7.3	2.7	3	PTB 09 ATEX 1020 X	0.24	400
K82R 250 M2 Ex de IIC T4 Y3	55	177	2970	IE3- 94.4	0.88	96	7.5	2.8	3.1	PTB 09 ATEX 1018 X	0.4	545
K82R 280 S2 Ex de IIC T4 Y3	75	241	2975	IE3- 94.8	0.88	130	7.1	2.3	2.8	PTB 09 ATEX 1018 X	0.65	700
K82R 280 M2 Ex de IIC T4 Y3	90	288	2980	IE3- 95.1	0.87	157	7.4	2.4	2.9	PTB 09 ATEX 1018 X	0.78	762
K82R 315 S2 Ex de IIC T4 Y3	110	353	2975	IE3- 95.4	0.89	187	7.1	2.2	2.6	PTB 09 ATEX 1018 X	1.4	960
K82R 315 M2 Ex de IIC T4 Y3	132	424	2975	IE3- 95.8	0.9	220	6.8	2.1	2.5	PTB 09 ATEX 1018 X	1.6	1025
K82R 315 L2 Ex de IIC T4 Y3	160	514	2980	IE3- 95.9	0.9	270	7.4	2.4	2.7	PTB 09 ATEX 1018 X	1.7	1065
K82R 315 LX2 Ex de IIC T4 Y3	200	614	2980	IE3- 96	0.9	335	6.9	2.3	2.6	PTB 09 ATEX 1018 X	2.2	1270
K82R 315 LY2 Ex de IIC T4 Y3	250	801	2980	IE3- 96	0.92	410	7.2	1.7	2.7	PTB 09 ATEX 1018 X	2.8	1420
K82R 355 L2 Ex de IIC T4 Y3	315	1009	2980	IE3- 96.6	0.92	510	6.7	1.5	2.8	PTB 09 ATEX 1021 X	4.5	1900
K82R 355 LX2 Ex de IIC T4 Y3	355	1136	2985	IE3- 96.8	0.93	570	6.9	1.4	2.7	PTB 09 ATEX 1021 X	5	2050
Efficiency according to manufacturer standard												
K82R 355 LX2 Ex de IIC T4	400	1280	2985	96.8	0.93	640	7	1.3	2.8		5.5	2350
K82R 400 L2 Ex de IIC T4	450	1437	2990	97	0.94	710	7.2	1.1	2.8		8.5	2910

Three-phase motors with squirrel-cage rotor, Premium Efficiency IE3
Type of explosion protection – Flameproof enclosure „d/de“ („db/db eb“)
for operation in Zone 1 according to EN 60079-1

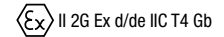

for rated voltage, temperature class T4
 with surface cooling, duty type S1, continuous duty
 thermal class F, degree of protection IP 55, 50 Hz

Motor selection data											Design point 400 V, 50 Hz	
Type	P _B	M _B	n _B	η _B	cosφ _B	I _B	I _A /I _B	M _A /M _B	M _K /M _B	ATEX no.	J	m
	kW	Nm	rpm	%	-	400 V A	-	-	-		kgm ²	kg
Synchronous speed 1500 rpm – 4-pole version												
Efficiency according to manufacturer standard												
K82R 63 M4 Ex de IIC T4	0.12	0.8	1445	67	0.60	0.43	5.6	3.9	3.9	PTB 09 ATEX 1017 X	0.00046	16
K82R 63 MX4 Ex de IIC T4	0.18	1.2	1415	70	0.70	0.53	4.7	2.7	2.7	PTB 09 ATEX 1017 X	0.00046	16
K82R 71 M4 Ex de IIC T4	0.25	1.7	1370	68.5	0.80	0.66	3.9	2	2.3	PTB 09 ATEX 1017 X	0.00046	16
K82R 71 MX4 Ex de IIC T4	0.37	2.6	1380	71	0.80	0.94	3.9	2.2	2.3	PTB 09 ATEX 1017 X	0.00063	17
K82R 80 M4 Ex de IIC T4	0.55	3.8	1380	72	0.80	1.36	3.8	2	2.3	PTB 09 ATEX 1018 X	0.00092	24
Efficiency according to IEC/EN 60034-30-1												
IE3-K82R 80 MX4 Ex de IIC T4	0.75	5	1445	IE3- 82.6	0.78	1.68	6.8	3.2	4.2	PTB 16 ATEX 1002 X	0.0029	35
IE3-K82R 90 S4 Ex de IIC T4	1.1	7.2	1455	IE3- 84.2	0.8	2.35	6.8	2.4	3.1	PTB 16 ATEX 1002 X	0.0046	44
IE3-K82R 90 L4 Ex de IIC T4	1.5	9.9	1450	IE3- 85.5	0.81	3.15	6.9	2.5	3.2	PTB 16 ATEX 1002 X	0.0056	46
IE3-K82R 100 L4 Ex de IIC T4	2.2	14.5	1450	IE3- 87.1	0.84	4.35	7.3	2.9	3.3	PTB 16 ATEX 1003 X	0.011	59
IE3-K82R 100 LX4 Ex de IIC T4	3	18.8	1450	IE3- 87.8	0.84	5.9	7.4	3.1	3.6	PTB 16 ATEX 1003 X	0.011	59
IE3-K82R 112 M4 Ex de IIC T4	4	26.2	1460	IE3- 88.7	0.83	7.8	7.2	3	3.4	PTB 16 ATEX 1003 X	0.022	100
IE3-K82R 132 S4 Ex de IIC T4	5.5	36	1460	IE3- 89.6	0.85	10.4	7.1	3.2	3.5	PTB 16 ATEX 1004 X	0.03	113
IE3-K82R 132 M4 Ex de IIC T4	7.5	49	1460	IE3- 90.5	0.86	13.9	7.4	3.1	3.3	PTB 16 ATEX 1004 X	0.041	125
K82R 160 M4 Ex de IIC T4 Y3	11	71	1470	IE3- 91.5	0.85	20.5	7.1	2.8	3.1	PTB 09 ATEX 1018 X	0.079	184
K82R 160 L4 Ex de IIC T4 Y3	15	97	1470	IE3- 92.1	0.83	28.5	7.4	3.1	3.4	PTB 09 ATEX 1018 X	0.092	208
K82R 180 M4 Ex de IIC T4 Y3	18.5	120	1470	IE3- 92.7	0.83	34.5	7.4	3.3	3.4	PTB 09 ATEX 1018 X	0.155	217
K82R 180 L4 Ex de IIC T4 Y3	22	143	1470	IE3- 93.2	0.83	41	7.4	3.3	3.3	PTB 09 ATEX 1019 X	0.197	272
K82R 200 L4 Ex de IIC T4 Y3	30	195	1470	IE3- 93.8	0.85	54	7.6	3.1	3.3	PTB 09 ATEX 1019 X	0.25	274
K82R 225 S4 Ex de IIC T4 Y3	37	240	1475	IE3- 93.9	0.85	67	7.1	3	2.9	PTB 09 ATEX 1020 X	0.4	372
K82R 225 M4 Ex de IIC T4 Y3	45	291	1475	IE3- 94.3	0.86	80	7.2	3.1	3	PTB 09 ATEX 1018 X	0.48	402
K82R 250 M4 Ex de IIC T4 Y3	55	356	1475	IE3- 94.6	0.88	95	7.3	3.1	3	PTB 09 ATEX 1018 X	0.75	588
K82R 280 S4 Ex de IIC T4 Y3	75	484	1480	IE3- 95.2	0.85	134	7.4	3	2.8	PTB 09 ATEX 1018 X	1.25	740
K82R 280 M4 Ex de IIC T4 Y3	90	579	1485	IE3- 95.3	0.85	160	7.8	3.2	3	PTB 09 ATEX 1018 X	1.48	820
K82R 315 S4 Ex de IIC T4 Y3	110	707	1485	IE3- 95.6	0.84	198	6.9	2.7	2.7	PTB 09 ATEX 1018 X	2.2	1040
K82R 315 M4 Ex de IIC T4 Y3	132	849	1485	IE3- 95.8	0.84	235	7	2.7	2.7	PTB 09 ATEX 1018 X	2.7	1120
K82R 315 L4 Ex de IIC T4 Y3	160	1026	1490	IE3- 96	0.84	285	7.4	2.8	2.8	PTB 09 ATEX 1018 X	3.1	1210
K82R 315 LX4 Ex de IIC T4 Y3	200	1286	1490	IE3- 96.1	0.85	355	6.9	2.6	2.6	PTB 09 ATEX 1018 X	3.9	1430
K82R 315 LY4 Ex de IIC T4 Y3	250	1602	1490	IE3- 96.2	0.87	430	7.3	1.7	2.7	PTB 09 ATEX 1018 X	4.6	1565
K82R 355 L4 Ex de IIC T4 Y3	315	2019	1490	IE3- 96.3	0.9	525	6.9	1.5	2.7	PTB 09 ATEX 1018 X	6.1	2050
K82R 355 LX4 Ex de IIC T4 Y3	355	2275	1490	IE3- 96.6	0.9	590	6.9	1.6	2.8	PTB 09 ATEX 1021 X	6.7	2200
Efficiency according to manufacturer standard												
K82R 355 LY4 Ex de IIC T4	400	2564	1490	97	0.90	665	7	1.5	2.8	PTB 09 ATEX 1021 X	7.4	2430
K82R 400 M4 Ex de IIC T4	450	2875	1495	97	0.91	735	7.3	1.1	2.7	PTB 09 ATEX 1022 X	18	2850
K82R 400 L4 Ex de IIC T4	500	3194	1495	97.1	0.91	815	7.3	1.1	2.7	PTB 09 ATEX 1022 X	20	3230
K82R 450 M4 Ex de IIC T4	560	3577	1495	97.2	0.91	915	6.8	1	2.7	PTB 09 ATEX 1023 X	26	3500
K82R 450 L4 Ex de IIC T4	630	4024	1495	97.4	0.91	1025	6.8	1	2.7	PTB 09 ATEX 1023 X	31	3800

Three-phase motors with squirrel-cage rotor, Premium Efficiency IE3
Type of explosion protection – Flameproof enclosure „d/de“ („db/db eb“)
for operation in Zone 1 according to EN 60079-1

II 2G Ex d/de IIC T4 Gb

for rated voltage, temperature class T4
 with surface cooling, duty type S1, continuous duty
 thermal class F, degree of protection IP 55, 50 Hz

Motor selection data											Design point 400 V, 50 Hz		
Type	P _B	M _B	n _B	η _B	cosφ _B	I _B	I _A /I _B	M _A /M _B	M _K /M _B	ATEX no.	J	m	
	kW	Nm	rpm	%	-	A	-	-	-		kgm ²	kg	
Synchronous speed 1000 rpm – 6-pole version													
Efficiency according to manufacturer standard													
K82R 71 MX6 Ex de IIC T4	0.25	2.6	920	62	0.71	0.82	3.5	2.2	2.6	PTB 09 ATEX 1017 X	0.0012	17	
K82R 80 M6 Ex de IIC T4	0.37	3.8	925	67	0.71	1.12	4.1	2.5	2.8	PTB 09 ATEX 1018 X	0.0019	24	
K82R 80 MX6 Ex de IIC T4	0.55	5.7	925	69	0.72	1.6	4	2.4	2.7	PTB 09 ATEX 1018 X	0.0025	25	
Efficiency according to IEC/EN 60034-30-1													
IE3-K82R 90 S6 Ex de IIC T4	0.75	7.5	955	IE3-	79.1	0.7	1.96	5.5	2.7	3.1	PTB 16 ATEX 1002 X	0.008	44
IE3-K82R 90 L6 Ex de IIC T4	1.1	11	955	IE3-	81.4	0.72	2.7	5.9	2.8	3.1	PTB 16 ATEX 1002 X	0.0095	46
IE3-K82R 100 L6 Ex de IIC T4	1.5	14.8	965	IE3-	83.5	0.71	3.65	6.8	3	3.3	PTB 16 ATEX 1003 X	0.017	59
IE3-K82R 112 M6 Ex de IIC T4	2.2	21.8	965	IE3-	85.5	0.78	4.75	6.8	2.6	3.1	PTB 16 ATEX 1003 X	0.031	100
IE3-K82R 132 S6 Ex de IIC T4	3	29.5	970	IE3-	85.7	0.74	6.8	7.1	3.2	3.7	PTB 16 ATEX 1004 X	0.031	100
IE3-K82R 132 M6 Ex de IIC T4	4	39.6	965	IE3-	87	0.76	8.7	6.9	2.9	3.7	PTB 16 ATEX 1004 X	0.037	104
IE3-K82R 132 MX6 Ex de IIC T4	5.5	54	965	IE3-	88.3	0.81	11.1	7.2	2.7	3.4	PTB 16 ATEX 1004 X	0.048	117
K82R 160 M6 Ex de IIC T4 Y3	7.5	74	970	IE3-	89.4	0.84	14.4	7.5	2.8	3.8	PTB 09 ATEX 1018 X	0.12	190
K82R 160 L6 Ex de IIC T4 Y3	11	108	975	IE3-	90.5	0.84	21	7.6	3	3.9	PTB 09 ATEX 1018 X	0.14	220
K82R 180 L6 Ex de IIC T4 Y3	15	147	975	IE3-	91.5	0.82	29	7.4	2.7	3.8	PTB 09 ATEX 1019 X	0.19	215
K82R 200 L6 Ex de IIC T4 Y3	18.5	181	975	IE3-	92	0.83	35	7	2.5	3.5	PTB 09 ATEX 1020 X	0.28	270
K82R 200 LX6 Ex de IIC T4 Y3	22	215	975	IE3-	92.4	0.84	41	6.9	2.2	3.2	PTB 09 ATEX 1020 X	0.31	280
K82R 225 M6 Ex de IIC T4 Y3	30	291	985	IE3-	93	0.83	56	6.9	3	2.7	PTB 09 ATEX 1018 X	0.69	404
K82R 250 M6 Ex de IIC T4 Y3	37	359	985	IE3-	93.5	0.83	69	6.8	3	2.7	PTB 09 ATEX 1018 X	1.03	570
K82R 280 S6 Ex de IIC T4 Y3	45	434	990	IE3-	93.9	0.82	84	6.6	2.8	2.4	PTB 09 ATEX 1018 X	1.35	720
K82R 280 M6 Ex de IIC T4 Y3	55	533	985	IE3-	94.4	0.81	104	6.5	2.8	2.4	PTB 09 ATEX 1018 X	1.7	770
K82R 315 S6 Ex de IIC T4 Y3	75	723	990	IE3-	94.9	0.88	130	7.2	3	2.7	PTB 09 ATEX 1018 X	4.3	995
K82R 315 M6 Ex de IIC T4 Y3	90	868	990	IE3-	95.2	0.88	155	7.7	3.2	2.8	PTB 09 ATEX 1018 X	5	1050
K82R 315 L6 Ex de IIC T4 Y3	110	1061	990	IE3-	95.5	0.88	189	7.8	3.3	2.8	PTB 09 ATEX 1018 X	6	1145
K82R 315 LX6 Ex de IIC T4 Y3	132	1273	990	IE3-	95.6	0.88	225	7.7	3.2	2.8	PTB 09 ATEX 1018 X	7.3	1265
K82R 315 LY6 Ex de IIC T4 Y3	160	1543	990	IE3-	95.8	0.88	275	7.8	3.3	2.8	PTB 09 ATEX 1018 X	8.3	1440
K82R 355 M6 Ex de IIC T4 Y3	200	1929	990	IE3-	95.9	0.87	345	6.7	1.8	2.7	PTB 09 ATEX 1021 X	11.3	1750
K82R 355 L6 Ex de IIC T4 Y3	250	2411	990	IE3-	95.9	0.88	430	6.7	1.8	2.7	PTB 09 ATEX 1021 X	13.8	1950
K82R 355 LX6 Ex de IIC T4 Y3	315	3039	990	IE3-	96	0.88	540	6.9	1.7	2.6	PTB 09 ATEX 1021 X	17.6	2300
K82R 400 M6 Ex de IIC T4 Y3	355	3411	990	IE3-	96.6	0.89	595	6.6	1.1	2.7	PTB 09 ATEX 1022 X	21	2850
Efficiency according to manufacturer standard													
K82R 400 L6 Ex de IIC T4	400	3843	994		96.6	0.89	670	6.8	1.1	2.6	PTB 09 ATEX 1022 X	31	3230
K82R 450 M6 Ex de IIC T4	450	4319	995		96.6	0.89	755	6.8	1.2	2.8	PTB 09 ATEX 1023 X	46	3500
K82R 450 L6 Ex de IIC T4	500	4799	995		97	0.89	835	6.8	1.1	2.7	PTB 09 ATEX 1023 X	51	3800

Three-phase motors with squirrel-cage rotor, High Efficiency IE2
Type of explosion protection – Flameproof enclosure „d/de“ („db/db eb“)
for operation in Zone 1 according to EN 60079-1

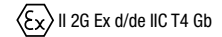

for rated voltage, temperature class T4
 with surface cooling, duty type S1, continuous duty
 thermal class F, degree of protection IP 55, 50 Hz

Motor selection data											Design point 400 V, 50 Hz	
Type	P _B	M _B	n _B	η _B	cosφ _B	I _B	I _A /I _B	M _A /M _B	M _K /M _B	ATEX no.	J	m
	kW	Nm	rpm	%	-	A	-	-	-		kgm ²	kg
Synchronous speed 3000 rpm – 2-pole version												
Efficiency according to manufacturer standard												
K82R 63 M2 Ex de IIC T4	0.18	0.6	2905	66	0.67	0.59	6.8	4.6	6.5	PTB 09 ATEX 1017 X	0.00028	16
K82R 63 MX2 Ex de IIC T4	0.25	0.8	2860	70	0.75	0.69	5.8	3.4	4.7	PTB 09 ATEX 1017 X	0.00028	16
K82R 71 M2 Ex de IIC T4	0.37	1.3	2800	71.5	0.84	0.89	5.2	2.7	3.5	PTB 09 ATEX 1017 X	0.00028	16
K82R 71 MX2 Ex de IIC T4	0.55	1.9	2810	72	0.82	1.34	5.5	2.8	3.6	PTB 09 ATEX 1017 X	0.00039	17
Efficiency according to IEC/EN 60034-30-1												
IE2-K82R 80 M2 Ex de IIC T4	0.75	2.48	2890	IE2- 79	0.87	1.58	6.6	3	3.6	PTB 16 ATEX 1002 X	0.0013	31
IE2-K82R 80 MX2 Ex de IIC T4	1.1	3.64	2885	IE2- 81.1	0.87	2.25	6.5	2.9	3.5	PTB 16 ATEX 1002 X	0.0018	35
IE2-K82R 90 S2 Ex de IIC T4	1.5	4.95	2895	IE2- 82.7	0.88	3	6.8	3	3.5	PTB 16 ATEX 1002 X	0.0029	45
IE2-K82R 90 L2 Ex de IIC T4	2.2	7.2	2900	IE2- 84.5	0.88	4.25	6.9	3	3.6	PTB 16 ATEX 1002 X	0.0039	48
IE2-K82R 100 L2 Ex de IIC T4	3	9.8	2910	IE2- 85.8	0.88	5.7	6.9	2.5	2.9	PTB 16 ATEX 1003 X	0.0051	53
IE2-K82R 112 M2 Ex de IIC T4	4	13	2930	IE2- 86.9	0.87	7.6	6.9	2.8	3.6	PTB 16 ATEX 1003 X	0.0089	95
IE2-K82R 132 S2 Ex de IIC T4	5.5	18	2925	IE2- 88.1	0.89	10.1	7	2.5	3.3	PTB 16 ATEX 1004 X	0.0125	103
IE2-K82R 132 SX2 Ex de IIC T4	7.5	24.4	2930	IE2- 89.1	0.89	13.7	7.1	2.7	3.5	PTB 16 ATEX 1004 X	0.0177	115
K82R 160 M2 Ex de IIC T4 Y2	11	35.7	2940	IE2- 90.3	0.87	20	7.3	3	3.6	PTB 09 ATEX 1018 X	0.032	163
K82R 160 MX2 Ex de IIC T4 Y2	15	48.7	2940	IE2- 91.1	0.9	26.5	7.2	2.8	3.2	PTB 09 ATEX 1018 X	0.043	173
K82R 160 L2 Ex de IIC T4 Y2	18.5	60	2940	IE2- 91.6	0.91	32	7.2	2.7	3.1	PTB 09 ATEX 1018 X	0.052	188
K82R 180 M2 Ex de IIC T4 Y2	22	71	2945	IE2- 92	0.91	38	7.5	2.6	3.2	PTB 09 ATEX 1018 X	0.075	196
K82R 200 L2 Ex de IIC T4 Y2	30	97	2955	IE2- 92.7	0.9	52	7.5	2.7	3.1	PTB 09 ATEX 1019 X	0.13	254
K82R 200 LX2 Ex de IIC T4 Y2	37	120	2955	IE2- 93.3	0.91	63	7.2	2.7	3	PTB 09 ATEX 1020 X	0.16	278
K82R 225 M2 Ex de IIC T4 Y2	45	145	2960	IE2- 93.4	0.9	77	7.3	2.7	3	PTB 09 ATEX 1020 X	0.24	400
K82R 250 M2 Ex de IIC T4 Y2	55	177	2970	IE2- 93.8	0.89	95	7.1	2.4	2.8	PTB 09 ATEX 1018 X	0.4	545
K82R 280 S2 Ex de IIC T4 Y2	75	241	2970	IE2- 94.5	0.9	129	6.8	2.2	2.7	PTB 09 ATEX 1018 X	0.65	700
K82R 280 M2 Ex de IIC T4 Y2	90	288	2970	IE2- 94.7	0.89	152	6.8	2.4	2.8	PTB 09 ATEX 1018 X	0.78	762
K82R 315 S2 Ex de IIC T4 Y2	110	353	2975	IE2- 95	0.89	188	6.5	2	2.4	PTB 09 ATEX 1018 X	1.4	960
K82R 315 M2 Ex de IIC T4 Y2	132	424	2975	IE2- 95.5	0.89	225	6.8	2.1	2.5	PTB 09 ATEX 1018 X	1.6	1025
K82R 315 L2 Ex de IIC T4 Y2	160	514	2975	IE2- 95.7	0.9	270	6.9	2.4	2.7	PTB 09 ATEX 1018 X	1.7	1065
K82R 315 LX2 Ex de IIC T4 Y2	200	614	2980	IE2- 95.8	0.9	335	6.9	2.3	2.6	PTB 09 ATEX 1018 X	2.2	1270
K82R 315 LY2 Ex de IIC T4 Y2	250	801	2980	IE2- 96	0.92	410	7.2	1.7	2.7	PTB 09 ATEX 1018 X	2.8	1420
K82R 355 L2 Ex de IIC T4 Y2	315	1009	2980	IE2- 96.6	0.92	510	6.7	1.5	2.8	PTB 09 ATEX 1021 X	4.5	1900
K82R 355 LX2 Ex de IIC T4 Y2	355	1036	2985	IE2- 96.8	0.93	570	6.9	1.4	2.7	PTB 09 ATEX 1021 X	5	2050
Efficiency according to manufacturer standard (IEC/EN 60034-2)												
K82R 355 LY2 Ex de IIC T4	400	1280	2985	96.8	0.94	640	7	1.3	2.8	PTB 09 ATEX 1021 X	5.5	2350
K82R 400 L2 Ex de IIC T4	450	1437.3	2990	97	0.94	710	7.2	1.1	2.8	PTB 09 ATEX 1022 X	8.5	2910

Three-phase motors with squirrel-cage rotor, High Efficiency IE2 Type of explosion protection – Flameproof enclosure „d/de“ („db/db eb“) for operation in Zone 1 according to EN 60079-1

for rated voltage, temperature class T4
with surface cooling, duty type S1, continuous duty
thermal class F, degree of protection IP 55, 50 Hz

Motor selection data										Design point 400 V, 50 Hz		
Type	P _B	M _B	n _B	η _B	cosφ _B	I _B	I _A /I _B	M _A /M _B	M _K /M _B	ATEX no.	J	m
	kW	Nm	rpm	%	-	A	-	-	-		kgm ²	kg
Synchronous speed 1500 rpm – 4-pole version												
Efficiency according to manufacturer standard												
K82R 63 M4 Ex de IIC T4	0.12	0.8	1445	67	0.60	0.43	5.6	3.9	3.9	PTB 09 ATEX 1017 X	0.00046	16
K82R 63 MX4 Ex de IIC T4	0.18	1.2	1415	70	0.70	0.53	4.7	2.7	2.7	PTB 09 ATEX 1017 X	0.00046	16
K82R 71 M4 Ex de IIC T4	0.25	1.7	1370	68.5	0.80	0.66	3.9	2	2.3	PTB 09 ATEX 1017 X	0.00046	16
K82R 71 MX4 Ex de IIC T4	0.37	2.6	1380	71	0.80	0.94	3.9	2.2	2.3	PTB 09 ATEX 1017 X	0.00063	17
K82R 80 M4 Ex de IIC T4	0.55	3.8	1380	72	0.80	1.36	3.8	2	2.3	PTB 09 ATEX 1018 X	0.00092	24
Efficiency according to IEC/EN 60034-30-1												
IE2-K82R 80 MX4 Ex de IIC T4	0.75	5	1445	IE2- 81	0.78	1.71	6.8	3.2	4.2	PTB 16 ATEX 1002 X	0.0029	35
IE2-K82R 90 S4 Ex de IIC T4	1.1	7.2	1455	IE2- 82.7	0.8	2.4	6.8	2.4	3.1	PTB 16 ATEX 1002 X	0.0046	44
IE2-K82R 90 L4 Ex de IIC T4	1.5	9.9	1450	IE2- 84	0.81	3.2	6.9	2.5	3.2	PTB 16 ATEX 1002 X	0.0056	46
IE2-K82R 100 L4 Ex de IIC T4	2.2	14.5	1450	IE2- 85.5	0.84	4.4	7.3	2.9	3.3	PTB 16 ATEX 1003 X	0.011	59
IE2-K82R 100 LX4 Ex de IIC T4	3	18.8	1450	IE2- 86.6	0.84	6	7.4	3.1	3.6	PTB 16 ATEX 1003 X	0.011	59
IE2-K82R 112 M4 Ex de IIC T4	4	26.2	1460	IE2- 87.6	0.83	7.9	7.2	3	3.4	PTB 16 ATEX 1003 X	0.022	100
IE2-K82R 132 S4 Ex de IIC T4	5.5	36	1460	IE2- 88.6	0.85	10.5	7.1	3.2	3.5	PTB 16 ATEX 1004 X	0.03	113
IE2-K82R 132 M4 Ex de IIC T4	7.5	49	1460	IE2- 89.5	0.86	14.1	7.4	3.1	3.3	PTB 16 ATEX 1004 X	0.041	125
K82R 160 M4 Ex de IIC T4 Y2	11	71	1470	IE2- 90.6	0.85	20.5	7.1	2.8	3.1	PTB 09 ATEX 1018 X	0.079	184
K82R 160 L4 Ex de IIC T4 Y2	15	97	1470	IE2- 91.3	0.83	28.5	7.4	3	3.3	PTB 09 ATEX 1018 X	0.083	187
K82R 180 M4 Ex de IIC T4 Y2	18.5	120	1470	IE2- 91.9	0.83	35	7.4	3.3	3.4	PTB 09 ATEX 1018 X	0.155	217
K82R 180 L4 Ex de IIC T4 Y2	22	143	1470	IE2- 92.3	0.83	41.5	7.3	3.3	3.3	PTB 09 ATEX 1019 X	0.164	225
K82R 200 L4 Ex de IIC T4 Y2	30	195	1470	IE2- 92.9	0.85	55	7.6	3.1	3.3	PTB 09 ATEX 1019 X	0.25	274
K82R 225 S4 Ex de IIC T4 Y2	37	240	1475	IE2- 93.3	0.85	67	7.1	3	2.9	PTB 09 ATEX 1020 X	0.4	372
K82R 225 M4 Ex de IIC T4 Y2	45	291	1475	IE2- 93.6	0.86	81	7.2	3.1	3	PTB 09 ATEX 1018 X	0.48	402
K82R 250 M4 Ex de IIC T4 Y2	55	356	1475	IE2- 94	0.88	96	7.3	3.1	3	PTB 09 ATEX 1018 X	0.75	588
K82R 280 S4 Ex de IIC T4 Y2	75	484	1480	IE2- 94.5	0.85	135	7.4	3	2.8	PTB 09 ATEX 1018 X	1.25	740
K82R 280 M4 Ex de IIC T4 Y2	90	579	1485	IE2- 94.7	0.85	161	7.8	3.2	3	PTB 09 ATEX 1018 X	1.48	820
K82R 315 S4 Ex de IIC T4 Y2	110	707	1485	IE2- 95.1	0.85	196	6.7	2.5	2.5	PTB 09 ATEX 1018 X	2.2	1040
K82R 315 M4 Ex de IIC T4 Y2	132	849	1485	IE2- 95.3	0.85	235	6.8	2.6	2.6	PTB 09 ATEX 1018 X	2.7	1120
K82R 315 L4 Ex de IIC T4 Y2	160	1026	1485	IE2- 95.6	0.86	280	6.9	2.7	2.6	PTB 09 ATEX 1018 X	3.1	1210
K82R 315 LX4 Ex de IIC T4 Y2	200	1286	1485	IE2- 95.8	0.86	350	6.9	2.7	2.6	PTB 09 ATEX 1018 X	3.9	1430
K82R 315 LY4 Ex de IIC T4 Y2	250	1602	1490	IE2- 96.2	0.87	430	7.3	1.7	2.7	PTB 09 ATEX 1018 X	4.6	1565
K82R 355 L4 Ex de IIC T4 Y2	315	2019	1490	IE2- 96.3	0.9	525	6.9	1.5	2.7	PTB 09 ATEX 1018 X	6.1	2050
K82R 355 LX4 Ex de IIC T4 Y2	355	2275	1490	IE2- 96.6	0.9	590	6.9	1.6	2.8	PTB 09 ATEX 1021 X	6.7	2200
Efficiency according to manufacturer standard												
K82R 355 LY4 Ex de IIC T4	400	2564	1490	97	0.90	665	7	1.5	2.8	PTB 09 ATEX 1021 X	7.4	2430
K82R 400 M4 Ex de IIC T4	450	2875	1495	97	0.91	735	7.3	1.1	2.7	PTB 09 ATEX 1022 X	18	2850
K82R 400 L4 Ex de IIC T4	500	3194	1495	97.1	0.91	815	7.3	1.1	2.7	PTB 09 ATEX 1022 X	20	3230
K82R 450 M4 Ex de IIC T4	560	3577	1495	97.2	0.91	915	6.8	1	2.7	PTB 09 ATEX 1023 X	26	3500
K82R 450 L4 Ex de IIC T4	630	4024	1495	97.4	0.91	1025	6.8	1	2.7	PTB 09 ATEX 1023 X	31	3800

Three-phase motors with squirrel-cage rotor, High Efficiency IE2
Type of explosion protection – Flameproof enclosure „d/de“ („db/db eb“)
for operation in Zone 1 according to EN 60079-1

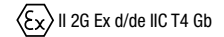

for rated voltage, temperature class T4
 with surface cooling, duty type S1, continuous duty
 thermal class F, degree of protection IP 55, 50 Hz

Motor selection data											Design point 400 V, 50 Hz	
Type	P _B	M _B	n _B	η _B	cosφ _B	I _B	I _A /I _B	M _A /M _B	M _K /M _B	ATEX no.	J	m
	kW	Nm	rpm	%	-	A	-	-	-		kgm ²	kg
Synchronous speed 1000 rpm – 6-pole version												
Efficiency according to manufacturer standard												
K82R 71 MX6 Ex de IIC T4	0.25	2.6	920	62	0.71	0.82	3.5	2.2	2.6	PTB 09 ATEX 1017 X	0.0012	17
K82R 80 M6 Ex de IIC T4	0.37	3.8	925	67	0.71	1.12	4.1	2.5	2.8	PTB 09 ATEX 1018 X	0.0019	24
K82R 80 MX6 Ex de IIC T4	0.55	5.7	925	69	0.72	1.6	4	2.4	2.7	PTB 09 ATEX 1018 X	0.0025	25
Efficiency according to IEC/EN 60034-30-1												
IE2-K82R 90 S6 Ex de IIC T4	0.75	7.5	955	IE2- 77.4	0.7	2	5.5	2.7	3.1	PTB 16 ATEX 1002 X	0.0080	44
IE2-K82R 90 L6 Ex de IIC T4	1.1	11	955	IE2- 79.5	0.72	2.75	5.9	2.8	3.1	PTB 09 ATEX 1002 X	0.0095	46
IE2-K82R 100 L6 Ex de IIC T4	1.5	14.8	965	IE2- 81.1	0.71	3.75	6.8	3	3.3	PTB 16 ATEX 1003 X	0.017	59
IE2-K82R 112 M6 Ex de IIC T4	2.2	21.8	965	IE2- 83	0.78	4.9	6.8	2.6	3.1	PTB 16 ATEX 1003 X	0.031	100
IE2-K82R 132 S6 Ex de IIC T4	3	29.5	970	IE2- 84.4	0.74	6.9	7.1	3.2	3.7	PTB 16 ATEX 1004 X	0.031	100
IE2-K82R 132 M6 Ex de IIC T4	4	39.6	965	IE2- 85.7	0.76	8.9	6.9	2.9	3.7	PTB 16 ATEX 1004 X	0.037	104
IE2-K82R 132 MX6 Ex de IIC T4	5.5	54	965	IE2- 87	0.81	11.3	7.2	2.7	3.4	PTB 16 ATEX 1004 X	0.048	117
K82R 160 M6 Ex de IIC T4 Y2	7.5	74	970	IE2- 88.1	0.84	14.6	7.5	2.8	3.8	PTB 09 ATEX 1018 X	0.12	190
K82R 160 L6 Ex de IIC T4 Y2	11	108	975	IE2- 89.5	0.81	22	7.6	2.9	3.9	PTB 09 ATEX 1018 X	0.12	190
K82R 180 L6 Ex de IIC T4 Y2	15	147	975	IE2- 90.4	0.82	29	7.4	2.7	3.8	PTB 09 ATEX 1019 X	0.19	215
K82R 200 L6 Ex de IIC T4 Y2	18.5	181	975	IE2- 91	0.83	35.5	7	2.5	3.5	PTB 09 ATEX 1020 X	0.28	270
K82R 200 LX6 Ex de IIC T4 Y2	22	215	975	IE2- 91.5	0.84	41.5	6.9	2.2	3.2	PTB 09 ATEX 1020 X	0.31	280
K82R 225 M6 Ex de IIC T4 Y2	30	291	985	IE2- 92.3	0.83	57	6.9	3	2.7	PTB 09 ATEX 1018 X	0.69	404
K82R 250 M6 Ex de IIC T4 Y2	37	359	985	IE2- 92.7	0.83	69	6.8	3	2.7	PTB 09 ATEX 1018 X	1.03	570
K82R 280 S6 Ex de IIC T4 Y2	45	434	985	IE2- 93.5	0.83	84	5.8	2.8	2.4	PTB 09 ATEX 1018 X	1.35	720
K82R 280 M6 Ex de IIC T4 Y2	55	533	985	IE2- 93.6	0.82	103	5.8	2.7	2.3	PTB 09 ATEX 1018 X	1.7	770
K82R 315 S6 Ex de IIC T4 Y2	75	723	990	IE2- 94.1	0.88	131	7.2	3	2.7	PTB 09 ATEX 1018 X	4.3	995
K82R 315 M6 Ex de IIC T4 Y2	90	868	990	IE2- 94.4	0.88	156	7.7	3.2	2.8	PTB 09 ATEX 1018 X	5	1050
K82R 315 L6 Ex de IIC T4 Y2	110	1061	990	IE2- 94.7	0.88	191	7.8	3.3	2.8	PTB 09 ATEX 1018 X	6	1145
K82R 315 LX6 Ex de IIC T4 Y2	132	1273	990	IE2- 95	0.88	230	7.7	3.2	2.8	PTB 09 ATEX 1018 X	7.3	1265
K82R 315 LY6 Ex de IIC T4 Y2	160	1543	990	IE2- 95.2	0.88	275	7.8	3.3	2.8	PTB 09 ATEX 1018 X	8.3	1440
K82R 355 M6 Ex de IIC T4 Y2	200	1929	990	IE2- 95.5	0.88	345	6.7	1.8	2.7	PTB 09 ATEX 1021 X	11.3	1750
K82R 355 L6 Ex de IIC T4 Y2	250	2411	990	IE2- 95.9	0.88	430	6.7	1.8	2.7	PTB 09 ATEX 1021 X	13.8	1950
K82R 355 LX6 Ex de IIC T4 Y2	315	3039	990	IE2- 96	0.88	540	6.9	1.7	2.6	PTB 09 ATEX 1021 X	17.6	2300
K82R 400 M6 Ex de IIC T4 Y2	355	3411	994	IE2- 96.6	0.89	595	6.6	1.7	2.7	PTB 09 ATEX 1022 X	27	2850
Efficiency according to manufacturer standard												
K82R 400 L 6 Ex de IIC T4	400	3843	994	96.6	0.89	670	6.8	1.1	2.6	PTB 09 ATEX 1022 X	31	3230
K82R 450 M 6 Ex de IIC T4	450	4319	995	96.6	0.89	755	6.8	1.2	2.8	PTB 09 ATEX 1023 X	46	3500
K82R 450 L6 Ex de IIC T4	500	4799	995	97	0.89	835	6.8	1.1	2.7	PTB 09 ATEX 1023 X	51	3800

Three-phase motors with squirrel-cage rotor, Standard Efficiency IE1
Type of explosion protection – Flameproof enclosure „d/de“ („db/db eb“)
for operation in Zone 1 according to EN 60079-1

for rated voltage, temperature class T4
 with surface cooling, duty type S1, continuous duty
 thermal class F, degree of protection IP 55, 50 Hz

Motor selection data											Design point 400 V, 50 Hz		
Type	P _B	M _B	n _B	η _B	cosφ _B	I _B	I _x /I _B	M _x /M _B	M _k /M _B	ATEX no.	J	m	
	kW	Nm	rpm	%	-	A	-	-	-		kgm ²	kg	
Synchronous speed 3000 rpm – 2-pole version													
K82R 63 M2 Ex de IIC T4	0.18	0.6	2905	66	0.67	0.59	6.8	4.6	6.5	PTB 09 ATEX 1017 X	0.00028	16	
K82R 63 MX2 Ex de IIC T4	0.25	0.8	2860	70	0.75	0.69	5.8	3.4	4.7	PTB 09 ATEX 1017 X	0.00028	16	
K82R 71 M2 Ex de IIC T4	0.37	1.3	2800	71.5	0.84	0.89	5.2	2.7	3.5	PTB 09 ATEX 1017 X	0.00028	16	
K82R 71 MX2 Ex de IIC T4	0.55	1.9	2810	72	0.82	1.34	5.5	2.8	3.6	PTB 09 ATEX 1017 X	0.00039	17	
K82R 80 M2 Ex de IIC T4	0.75	2.6	2790	IE1-	74.5	0.84	1.73	4.8	2.7	3.3	PTB 09 ATEX 1018 X	0.00058	24
K82R 80 MX2 Ex de IIC T4	1.1	3.7	2820	IE1-	78	0.82	2.5	5.5	2.8	3.5	PTB 09 ATEX 1018 X	0.0008	25
K82R 90 S2 Ex de IIC T4	1.5	5	2840	IE1-	77	0.86	3.25	5.9	2.9	3.2	PTB 09 ATEX 1018 X	0.0013	31
K82R 90 L2 Ex de IIC T4	2.2	7.4	2850	IE1-	82	0.85	4.55	6.3	3	3.5	PTB 09 ATEX 1018 X	0.0018	35
K82R 100 L2 Ex de IIC T4	3	10	2850	IE1-	82	0.87	6.1	6.8	2.7	3.3	PTB 09 ATEX 1018 X	0.0029	45
K82R 112 M2 Ex de IIC T4	4	13	2880	IE1-	85	0.88	7.7	6.5	2.3	3.1	PTB 09 ATEX 1018 X	0.0051	53
K82R 132 S2 Ex de IIC T4	5.5	18	2880	IE1-	85.5	0.87	10.7	6.4	2.5	3.3	PTB 09 ATEX 1018 X	0.0089	95
K82R 132 SX2 Ex de IIC T4	7.5	25	2910	IE1-	86.5	0.87	14.4	6.8	2.7	3.5	PTB 09 ATEX 1018 X	0.0125	100
K82R 160 M2 Ex de IIC T4	11	36	2925	IE1-	89	0.89	20	6.6	2.8	3.2	PTB 09 ATEX 1018 X	0.032	163
K82R 160 MX2 Ex de IIC T4	15	49	2920	IE1-	89	0.91	26.5	6.8	2.8	3.2	PTB 09 ATEX 1018 X	0.043	173
K82R 160 L2 Ex de IIC T4	18.5	60	2925	IE1-	90.5	0.92	32	6.8	2.6	3.1	PTB 09 ATEX 1018 X	0.052	188
K82R 180 M2 Ex de IIC T4	22	72	2925	IE1-	91.5	0.92	37.5	6.9	2.5	3	PTB 09 ATEX 1019 X	0.075	196
K82R 200 L2 Ex de IIC T4	30	97	2955	IE1-	92.5	0.90	52	7.2	2.6	2.9	PTB 09 ATEX 1020 X	0.13	254
K82R 200 LX2 Ex de IIC T4	37	120	2955	IE1-	93.3	0.91	63	7.2	2.7	3	PTB 09 ATEX 1020 X	0.16	278
K82R 225 M2 Ex de IIC T4	45	145	2960	IE1-	93	0.89	78	7.1	2.5	3	PTB 09 ATEX 1018 X	0.24	400
K82R 250 M2 Ex de IIC T4	55	177	2970	IE1-	93.8	0.89	95	7.1	2.4	2.8	PTB 09 ATEX 1018 X	0.4	545
K82R 280 S2 Ex de IIC T4	75	241	2970	IE1-	94.5	0.89	129	6.8	2.2	2.7	PTB 09 ATEX 1018 X	0.65	700
K82R 280 M2 Ex de IIC T4	90	289	2970	IE1-	94.7	0.9	152	6.8	2.4	2.8	PTB 09 ATEX 1018 X	0.78	762
K82R 315 S2 Ex de IIC T4	110	353	2975	IE1-	95	0.89	188	6.5	2	2.4	PTB 09 ATEX 1018 X	1.4	960
K82R 315 M2 Ex de IIC T4	132	424	2975	IE1-	95.5	0.89	225	6.8	2.1	2.5	PTB 09 ATEX 1018 X	1.6	1025
K82R 315 L2 Ex de IIC T4	160	514	2975	IE1-	95.7	0.90	270	6.9	2.4	2.7	PTB 09 ATEX 1018 X	1.9	1065
K82R 315 LX2 Ex de IIC T4	200	641	2980	IE1-	95.8	0.90	335	6.9	2.3	2.6	PTB 09 ATEX 1018 X	2.2	1270
K82R 315 LY2 Ex de IIC T4	250	801	2980	IE1-	96	0.92	410	7.2	1.7	2.7	PTB 09 ATEX 1018 X	2.8	1420
K82R 355 L2 Ex de IIC T4	315	1009	2980	IE1-	96.6	0.92	510	6.7	1.5	2.8	PTB 09 ATEX 1021 X	4.5	1900
K82R 355 LX2 Ex de IIC T4	355	1136	2985	IE1-	96.8	0.93	570	6.9	1.4	2.7	PTB 09 ATEX 1021 X	5	2050
K82R 355 LY2 Ex de IIC T4	400	1280	2985		96.8	0.94	640	7	1.3	2.8	PTB 09 ATEX 1021 X	5.5	2350
K82R 400 L2 Ex de IIC T4	450	1437	2990		97	0.94	710	7.2	1.1	2.8	PTB 09 ATEX 1022 X	8.5	2910

Three-phase motors with squirrel-cage rotor, Standard Efficiency IE1
Type of explosion protection – Flameproof enclosure „d/de“ („db/db eb“)
for operation in Zone 1 according to EN 60079-1

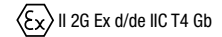

for rated voltage, temperature class T4
 with surface cooling, duty type S1, continuous duty
 thermal class F, degree of protection IP 55, 50 Hz

Motor selection data											Design point 400 V, 50 Hz		
Type	P _B	M _B	n _B	η _B	cosφ _B	I _B	I _x /I _B	M _x /M _B	M _k /M _B	ATEX no.	J	m	
	kW	Nm	rpm	%	-	400 V A	-	-	-		kgm ²	kg	
Synchronous speed 1500 rpm – 4-pole version													
K82R 63 M4 Ex de IIC T4	0.12	0.8	1445	67	0.60	0.43	5.6	3.9	3.9	PTB 09 ATEX 1017 X	0.00046	16	
K82R 63 MX4 Ex de IIC T4	0.18	1.2	1415	70	0.70	0.53	4.7	2.7	2.7	PTB 09 ATEX 1017 X	0.00046	16	
K82R 71 M4 Ex de IIC T4	0.25	1.7	1370	68.5	0.80	0.66	3.9	2	2.3	PTB 09 ATEX 1017 X	0.00046	16	
K82R 71 MX4 Ex de IIC T4	0.37	2.6	1380	71	0.80	0.94	3.9	2.2	2.3	PTB 09 ATEX 1017 X	0.00063	17	
K82R 80 M4 Ex de IIC T4	0.55	3.8	1380	72	0.80	1.36	3.8	2	2.3	PTB 09 ATEX 1018 X	0.00092	24	
K82R 80 MX4 Ex de IIC T4	0.75	5.1	1400	IE1-	75.5	0.79	1.81	4.5	2.1	2.5	PTB 09 ATEX 1018 X	0.0013	25
K82R 90 S4 Ex de IIC T4	1.1	7.5	1400	IE1-	76	0.83	2.55	4.8	2.1	2.5	PTB 09 ATEX 1018 X	0.0021	31
K82R 90 L4 Ex de IIC T4	1.5	10	1405	IE1-	79	0.82	3.35	5	2.3	2.7	PTB 09 ATEX 1018 X	0.0029	35
K82R 100 L4 Ex de IIC T4	2.2	15	1420	IE1-	80	0.8	4.95	5.4	2.4	2.8	PTB 09 ATEX 1018 X	0.0046	44
K82R 100 LX4 Ex de IIC T4	3	20	1415	IE1-	81.7	0.82	6.5	5.5	2.3	2.7	PTB 09 ATEX 1018 X	0.0056	46
K82R 112 M4 Ex de IIC T4	4	27	1435	IE1-	85	0.84	8.1	6.8	2.7	3.2	PTB 09 ATEX 1018 X	0.011	59
K82R 132 S4 Ex de IIC T4	5.5	36	1440	IE1-	86.5	0.85	10.8	6.4	2.5	2.7	PTB 09 ATEX 1018 X	0.022	100
K82R 132 M4 Ex de IIC T4	7.5	50	1440	IE1-	88	0.86	14.3	6.5	2.7	2.8	PTB 09 ATEX 1018 X	0.03	110
K82R 160 M4 Ex de IIC T4	11	72	1460	IE1-	89.5	0.85	21	6.6	2.5	2.8	PTB 09 ATEX 1018 X	0.057	168
K82R 160 L4 Ex de IIC T4	15	98	1455	IE1-	90	0.86	28	6.7	2.8	3.1	PTB 09 ATEX 1018 X	0.079	184
K82R 180 M4 Ex de IIC T4	18.5	121	1460	IE1-	91	0.84	35	6.7	2.9	3	PTB 09 ATEX 1019 X	0.13	198
K82R 180 L4 Ex de IIC T4	22	144	1460	IE1-	91.5	0.84	41.5	6.9	3	3	PTB 09 ATEX 1019 X	0.155	217
K82R 200 L4 Ex de IIC T4	30	196	1460	IE1-	92.5	0.88	53	6.8	2.6	2.9	PTB 09 ATEX 1020 X	0.25	274
K82R 225 S4 Ex de IIC T4	37	241	1465	IE1-	93	0.88	65	6.7	2.7	2.6	PTB 09 ATEX 1018 X	0.4	372
K82R 225 M4 Ex de IIC T4	45	292	1470	IE1-	93.5	0.88	79	6.5	2.7	2.6	PTB 09 ATEX 1018 X	0.48	402
K82R 250 M4 Ex de IIC T4	55	357	1470	IE1-	93.8	0.89	95	7.1	2.9	2.9	PTB 09 ATEX 1018 X	0.75	573
K82R 280 S4 Ex de IIC T4	75	484	1480	IE1-	94	0.86	134	6.8	2.6	2.5	PTB 09 ATEX 1018 X	1.25	740
K82R 280 M4 Ex de IIC T4	90	581	1480	IE1-	94.5	0.86	160	6.9	2.8	2.6	PTB 09 ATEX 1018 X	1.48	820
K82R 315 S4 Ex de IIC T4	110	707	1485	IE1-	95.1	0.85	196	6.7	2.5	2.5	PTB 09 ATEX 1018 X	2.2	1040
K82R 315 M4 Ex de IIC T4	132	849	1485	IE1-	95.3	0.85	235	6.8	2.6	2.6	PTB 09 ATEX 1018 X	2.7	1120
K82R 315 L4 Ex de IIC T4	160	1029	1485	IE1-	95.6	0.86	280	6.9	2.7	2.6	PTB 09 ATEX 1018 X	3.1	1210
K82R 315 LX4 Ex de IIC T4	200	1286	1485	IE1-	95.8	0.86	350	6.9	2.7	2.6	PTB 09 ATEX 1018 X	3.9	1430
K82R 315 LY4 Ex de IIC T4	250	1602	1490	IE1-	96.2	0.87	430	7.3	1.7	2.7	PTB 09 ATEX 1018 X	4.6	1565
K82R 355 L4 Ex de IIC T4	315	2019	1490	IE1-	96.3	0.9	525	6.9	1.5	2.7	PTB 09 ATEX 1021 X	6.1	2050
K82R 355 LX4 Ex de IIC T4	355	2275	1490	IE1-	96.6	0.90	590	6.9	1.6	2.8	PTB 09 ATEX 1021 X	6.7	2200
K82R 355 LY4 Ex de IIC T4	400	2564	1490		97	0.90	665	7	1.5	2.8	PTB 09 ATEX 1021 X	7.4	2430
K82R 400 M4 Ex de IIC T4	450	2875	1495		97	0.91	735	7.3	1.1	2.7	PTB 09 ATEX 1022 X	18	2850
K82R 400 L4 Ex de IIC T4	500	3194	1495		97.1	0.91	815	7.3	1.1	2.7	PTB 09 ATEX 1022 X	20	3230
K82R 450 M4 Ex de IIC T4	560	3577	1495		97.2	0.91	915	6.8	1	2.7	PTB 09 ATEX 1023 X	26	3500
K82R 450 L4 Ex de IIC T4	630	4024	1495		97.4	0.91	1025	6.8	1	2.7	PTB 09 ATEX 1023 X	31	3800

Three-phase motors with squirrel-cage rotor, Standard Efficiency IE1 Type of explosion protection – Flameproof enclosure „d/de“ („db/db eb“) for operation in Zone 1 according to EN 60079-1

for rated voltage, temperature class T4
with surface cooling, duty type S1, continuous duty
thermal class F, degree of protection IP 55, 50 Hz

Motor selection data											Design point 400 V, 50 Hz		
Type	P _B kW	M _B Nm	n _B rpm	η _B %	cosφ _B -	I _B 400 V A	I _N /I _B -	M _N /M _B -	M _K /M _B -	ATEX no.	J kgm ²	m kg	
Synchronous speed 1000 rpm – 6-pole version													
K82R 71 MX6 Ex de IIC T4	0.25	2.6	920	62	0.71	0.82	3.5	2.2	2.6	PTB 09 ATEX 1017 X	0.0012	17	
K82R 80 M6 Ex de IIC T4	0.37	3.8	925	67	0.71	1.12	4.1	2.5	2.8	PTB 09 ATEX 1018 X	0.0019	24	
K82R 80 MX6 Ex de IIC T4	0.55	5.7	925	69	0.72	1.6	4	2.4	2.7	PTB 09 ATEX 1018 X	0.0025	25	
K82R 90 S6 Ex de IIC T4	0.75	7.9	910	IE1- 70.2	0.75	2.15	3.4	1.8	2.1	PTB 09 ATEX 1018 X	0.0033	31	
K82R 90 L6 Ex de IIC T4	1.1	11.4	920	IE1- 73	0.73	3.05	3.7	2	2.2	PTB 09 ATEX 1018 X	0.0046	35	
K82R 100 L6 Ex de IIC T4	1.5	15	945	IE1- 77	0.75	3.75	4.9	2.5	3	PTB 09 ATEX 1018 X	0.0095	46	
K82R 112 M6 Ex de IIC T4	2.2	22	950	IE1- 81	0.75	5.2	5.6	2.7	3.1	PTB 09 ATEX 1018 X	0.017	59	
K82R 132 S6 Ex de IIC T4	3	30	965	IE1- 84	0.78	6.6	6.3	2.7	3.1	PTB 09 ATEX 1018 X	0.031	100	
K82R 132 M6 Ex de IIC T4	4	40	965	IE1- 85	0.79	8.6	6	2.6	3	PTB 09 ATEX 1018 X	0.037	104	
K82R 132 MX6 Ex de IIC T4	5.5	55	960	IE1- 86	0.81	11.4	6.4	2.6	3	PTB 09 ATEX 1018 X	0.043	112	
K82R 160 M6 Ex de IIC T4	7.5	75	960	IE1- 86.8	0.85	14.7	6.8	2.5	3.3	PTB 09 ATEX 1018 X	0.087	170	
K82R 160 L6 Ex de IIC T4	11	109	965	IE1- 87.5	0.86	21	6.7	2.5	3.2	PTB 09 ATEX 1018 X	0.12	190	
K82R 180 L6 Ex de IIC T4	15	148	965	IE1- 90	0.84	28.5	6.9	2.4	3.2	PTB 09 ATEX 1019 X	0.19	215	
K82R 200 L6 Ex de IIC T4	18.5	181	975	IE1- 90.5	0.84	35	6.3	1.9	2.7	PTB 09 ATEX 1020 X	0.28	270	
K82R 200 LX6 Ex de IIC T4	22	217	970	IE1- 91	0.85	41	6.8	2.2	3	PTB 09 ATEX 1020 X	0.31	280	
K82R 225 M6 Ex de IIC T4	30	294	975	IE1- 92	0.84	56	6.6	2.8	2.5	PTB 09 ATEX 1018 X	0.69	404	
K82R 250 M6 Ex de IIC T4	37	361	980	IE1- 92.5	0.84	69	6.6	2.8	2.6	PTB 09 ATEX 1018 X	1.03	570	
K82R 280 S6 Ex de IIC T4	45	436	985	IE1- 93.5	0.83	84	5.8	2.8	2.4	PTB 09 ATEX 1018 X	1.35	720	
K82R 280 M6 Ex de IIC T4	55	533	985	IE1- 93.5	0.82	104	5.8	2.7	2.3	PTB 09 ATEX 1018 X	1.7	770	
K82R 315 S6 Ex de IIC T4	75	723	990	IE1- 94	0.87	132	6.4	2.6	2.4	PTB 09 ATEX 1018 X	4.3	995	
K82R 315 M6 Ex de IIC T4	90	868	990	IE1- 94.2	0.88	157	6.5	2.6	2.4	PTB 09 ATEX 1018 X	5	1050	
K82R 315 L6 Ex de IIC T4	110	1061	990	IE1- 94.5	0.88	191	6.5	2.7	2.5	PTB 09 ATEX 1018 X	6	1145	
K82R 315 LX6 Ex de IIC T4	132	1273	990	IE1- 94.7	0.88	230	6.7	2.7	2.5	PTB 09 ATEX 1018 X	7.3	1265	
K82R 315 LY6 Ex de IIC T4	160	1543	990	IE1- 95	0.88	275	6.8	2.6	2.5	PTB 09 ATEX 1018 X	8.3	1440	
K82R 355 M6 Ex de IIC T4	200	1929	990	IE1- 95.5	0.88	345	6.7	1.8	2.7	PTB 09 ATEX 1021 X	11.3	1750	
K82R 355 L6 Ex de IIC T4	250	2412	990	IE1- 95.9	0.88	430	6.7	1.8	2.7	PTB 09 ATEX 1021 X	13.8	1950	
K82R 355 LX6 Ex de IIC T4	315	3039	990	IE1- 96	0.88	540	6.9	1.7	2.6	PTB 09 ATEX 1021 X	17.6	2300	
K82R 400 M6 Ex de IIC T4	355	3411	994	IE1- 96.6	0.89	595	6.6	1.1	2.7	PTB 09 ATEX 1022 X	27	2850	
K82R 400 L6 Ex de IIC T4	400	3843	994	96.6	0.89	670	6.8	1.1	2.6	PTB 09 ATEX 1022 X	31	3230	
K82R 450 M6 Ex de IIC T4	450	4319	995	96.6	0.89	755	6.8	1.2	2.8	PTB 09 ATEX 1023 X	46	3500	
K82R 450 L6 Ex de IIC T4	500	4799	995	97	0.89	835	6.8	1.1	2.7	PTB 09 ATEX 1023 X	51	3800	
Synchronous speed 750 rpm – 8-pole version													
K82R 71 MX8 Ex de IIC T4	0.12	1.7	680	51	0.65	0.52	2.6	1.9	2.4	PTB 09 ATEX 1017 X	0.0012	17	
K82R 80 M8 Ex de IIC T4	0.18	2.5	690	61	0.65	0.66	3.2	2.2	2.6	PTB 09 ATEX 1018 X	0.0019	24	
K82R 80 MX8 Ex de IIC T4	0.25	3.5	690	62	0.64	0.91	3.2	2.2	2.5	PTB 09 ATEX 1018 X	0.0025	25	
K82R 90 S8 Ex de IIC T4	0.37	5.1	690	63	0.65	1.3	3	1.8	2.2	PTB 09 ATEX 1018 X	0.0033	31	
K82R 90 L8 Ex de IIC T4	0.55	7.6	690	67	0.65	1.85	3.1	1.8	2.2	PTB 09 ATEX 1018 X	0.0046	35	
K82R 100 L8 Ex de IIC T4	0.75	9.9	720	77	0.64	2.2	5	2.3	2.9	PTB 09 ATEX 1018 X	0.017	59	
K82R 100 LX8 Ex de IIC T4	1.1	15	715	78	0.68	3	4.8	2.2	2.7	PTB 09 ATEX 1018 X	0.017	59	
K82R 112 M8 Ex de IIC T4	1.5	20	705	80.6	0.76	3.55	4.9	2	2.6	PTB 09 ATEX 1018 X	0.029	97	
K82R 132 S8 Ex de IIC T4	2.2	30	710	81.2	0.72	5.4	5.4	2.3	2.7	PTB 09 ATEX 1018 X	0.029	97	
K82R 132 M8 Ex de IIC T4	3	40	715	92.9	0.72	7.3	6.3	2.7	3.1	PTB 09 ATEX 1018 X	0.036	113	
K82R 160 M8 Ex de IIC T4	4	53	725	95.5	0.77	8.8	5.6	1.9	3.1	PTB 09 ATEX 1018 X	0.071	157	
K82R 160 MX8 Ex de IIC T4	5.5	72	725	87.1	0.76	12	6	2.3	3.2	PTB 09 ATEX 1018 X	0.105	170	
K82R 160 L8 Ex de IIC T4	7.5	99	725	87.9	0.74	16.6	6.1	2.4	3.3	PTB 09 ATEX 1018 X	0.136	190	
K82R 180 L8 Ex de IIC T4	11	145	725	89.2	0.78	23	6.9	2.6	3.3	PTB 09 ATEX 1019 X	0.22	215	
K82R 200 L8 Ex de IIC T4	15	196	730	90.3	0.77	31	7.1	2.4	3.3	PTB 09 ATEX 1020 X	0.4	280	
K82R 225 S8 Ex de IIC T4	18.5	240	735	91.1	0.78	37.5	7.1	2.3	3.1	PTB 09 ATEX 1017 X	0.56	372	
K82R 225 M8 Ex de IIC T4	22	286	735	91.5	0.78	44.5	7.2	2.4	3.4	PTB 09 ATEX 1018 X	0.69	404	
K82R 250 M8 Ex de IIC T4	30	390	735	92.5	0.82	57	6.8	2	2.8	PTB 09 ATEX 1018 X	1.2	550	
K82R 280 S8 Ex de IIC T4	37	481	735	92.9	0.82	70	6.5	2	2.9	PTB 09 ATEX 1018 X	1.9	740	
K82R 280 M8 Ex de IIC T4	45	581	740	93.2	0.82	85	6.7	2.2	2.9	PTB 09 ATEX 1018 X	2.3	800	
K82R 315 S8 Ex de IIC T4	55	710	740	94	0.8	106	7.1	2	2.7	PTB 09 ATEX 1018 X	4.3	995	
K82R 315 M8 Ex de IIC T4	75	968	740	94.5	0.8	143	7	2	2.7	PTB 09 ATEX 1018 X	5	1050	
K82R 315 L8 Ex de IIC T4	90	1161	740	94.9	0.8	171	7.2	2.1	2.8	PTB 09 ATEX 1018 X	6	1145	
K82R 315 LX8 Ex de IIC T4	110	1420	740	95.2	0.81	205	7.1	2	2.7	PTB 09 ATEX 1018 X	7.3	1265	
K82R 315 LY8 Ex de IIC T4	132	1704	740	95.4	0.8	250	7.3	2.1	2.8	PTB 09 ATEX 1018 X	8.3	1440	
K82R 355 M8 Ex de IIC T4	160	2051	745	95.8	0.82	295	7.2	1.9	2.7	PTB 09 ATEX 1021 X	11.4	1750	
K82R 355 L8 Ex de IIC T4	200	2564	745	95.8	0.82	370	6.6	1.7	2.5	PTB 09 ATEX 1021 X	13.9	1950	
K82R 355 LX8 Ex de IIC T4	250	3205	745	95.8	0.82	460	6.1	1.2	2.4	PTB 09 ATEX 1021 X	17.7	2300	
K82R 400 M8 Ex de IIC T4	315	4038	745	96.2	0.83	570	6.2	1.2	2.4	PTB 09 ATEX 1022 X	30	3100	
K82R 400 L8 Ex de IIC T4	355	4551	745	96.3	0.83	640	6.1	1	2.4	PTB 09 ATEX 1022 X	34	3440	
K82R 450 M8 Ex de IIC T4	400	5128	745	96.6	0.84	710	6.1	1	2.2	PTB 09 ATEX 1023 X	51	3750	
K82R 450 L8 Ex de IIC T4	450	5768	745	96.7	0.84	800	6.1	1	2.2	PTB 09 ATEX 1023 X	57	4050	

Three-phase motors with squirrel-cage rotor with built-in brake
Type of explosion protection – Flameproof enclosure „d/de“ („db/db eb“)
for operation in Zone 1 according to EN 60079-0/60079-1

for mains operation, temperature class T4
 Version for rated voltage range A according to IEC/EN 60034-1, 50 Hz
 With surface cooling, duty type S1, continuous duty
 Degree of protection IP 55, thermal class 155

Motor selection data

Type	Output P ₂ kW	Rated current at		Speed n _B rpm	Efficiency η _B %	Power factor cosφ _B -	Starting torque M _N /M _N -	Starting current I _N /I _N -	Motor torque M Nm	Braking torque M _e ¹⁾ Nm	Moment of inertia J kgm ²	Weight m ²⁾ kg	Permissible cyclic duration factor per hour under duty type S4 15, 20, 40 or 60 % c.d.f.			
		400 V A	500 V A										FI=1.5 S/h	FI=2 S/h	FI=3 S/h	FI=4 S/h
Synchronous speed 3000 rpm – 2-pole version																
B82R 80 K2	0.75	1.84	1.47	2790	70	0.84	2.7	4.8	2.57	10	0.000925	26	1110	935	710	570
B82R 80 L2	1.1	2.6	2.05	2820	75	0.82	2.8	5.5	3.7	10	0.00118	27	580	495	435	320
B82R 90 L2	1.5	3.25	2.6	2840	77	0.86	2.7	5.5	5	20	0.00193	38	130	115	90	80
B82R 90 LX2	2.2	4.6	3.7	2850	81	0.85	2.7	5.6	7.4	20	0.00240	42	184	165	135	115
B82R 100 L2	3	6.1	4.85	2850	82	0.87	2.7	6.8	10.1	46	0.00365	51	71	65	54	47
B82R 112 M2	4	7.8	6.2	2880	84	0.88	2.3	6.5	13.3	46	0.00638	64	140	120	95	75
B82R 132 S2	5.5	10.9	8.7	2880	84	0.87	2.5	6.4	18.2	86	0.013	113	53	46	37	30
B82R 132 SX2	7.5	14.6	11.7	2910	85	0.87	2.7	6.8	24.7	86	0.0159	118	70	60	45	40
Synchronous speed 1500 rpm – 4-pole version																
B82R 80 K4	0.55	1.38	1.1	1380	72	0.8	2	3.8	3.8	10	0.0013	26	1340	1185	960	800
B82R 80 L4	0.75	1.85	1.48	1400	74	0.79	2.1	4.2	5.2	10	0.00168	27	1340	1170	930	640
B82R 90 L4	1.1	2.55	2.05	1400	75	0.83	2.1	4.8	7.5	20	0.003	38	230	205	170	145
B82R 90 LX4	1.5	3.4	2.7	1405	78	0.82	2.3	5	10.3	20	0.00525	42	270	245	200	170
B82R 100 L4	2.2	5	4	1420	79	0.8	2.4	5.4	14.8	46	0.00688	51	235	215	185	165
B82R 100 LX4	3	6.6	5.2	1415	79.5	0.83	2.3	5.5	20.1	46	0.007	54	110	105	90	80
B82R 112 M4	4	8.2	6.5	1435	84	0.84	2.7	6.8	26.5	46	0.0133	69	220	210	180	160
B82R 132 S4	5.5	11	8.8	1440	85	0.85	2.5	6.2	36.5	86	0.0263	118	100	95	75	65
B82R 132 M4	7.5	14.5	11.6	1440	87	0.86	2.7	6.5	50	86	0.0348	128	100	90	75	65
Synchronous speed 1000 rpm – 6-pole version																
B82R 80 K6	0.37	1.12	0.9	925	67	0.71	2.5	4.1	3.8	10	0.0024	26	1120	950	725	590
B82R 80 L6	0.55	1.6	1.28	925	69	0.72	2.4	4	5.7	10	0.003	27	1145	980	765	620
B82R 90 L6	0.75	2.2	1.75	910	66	0.75	1.8	3.4	7.8	20	0.00445	38	675	605	500	425
B82R 90 LX6	1.1	3.1	2.5	920	70	0.73	2	3.7	11.4	20	0.00573	42	125	115	100	85
B82R 100 L6	1.5	3.8	3.05	945	76	0.75	2.5	4.9	15.2	46	0.0113	54	240	215	175	145
B82R 112 M6	2.2	5.47	4.3	950	80	0.74	2.7	5.6	22.1	46	0.0198	69	595	530	425	355
B82R 132 S6	3	6.7	5.4	965	83	0.78	2.7	6.3	29.8	86	0.0347	118	390	350	290	250
B82R 132 M6	4	8.8	7	960	83.5	0.79	2.6	6	40	86	0.0415	124	215	195	160	140
B82R 132 MX6	5.5	11.6	9.3	960	84.5	0.81	2.6	6.4	55	86	0.0498	133	125	110	95	80
Synchronous speed 750 rpm – 8-pole version																
B82R 80 K8	0.18	0.66	0.52	690	61	0.65	2.2	3.2	2.5	10	0.0023	26	1125	940	710	580
B82R 80 L8	0.25	0.91	0.73	690	62	0.64	2.2	3.2	3.5	10	0.0029	27	1125	940	710	580
B82R 90 L8	0.37	1.3	1.04	690	63	0.65	1.8	3	5.1	20	0.0039	38	1285	1090	920	780
B82R 90 LX8	0.55	1.92	1.54	690	64.5	0.64	1.8	3.1	7.6	20	0.0052	42	1160	980	830	690
B82R 100 L8	0.75	2.35	1.87	710	70	0.66	2.4	4	10.2	46	0.0094	51	970	820	690	570
B82R 100 LX8	1.1	3.1	2.5	695	70	0.73	2	3.8	15.1	46	0.0109	54	880	750	630	520
B82R 112 M8	1.5	4.2	3.35	710	77	0.67	2.2	4.6	20.5	46	0.0198	69	680	560	480	406
B82R 132 S8	2.2	5	4	695	80	0.79	2	4.1	30	86	0.0331	113	650	550	460	380
B82R 132 M8	3	7	5.6	705	80.5	0.77	2.4	4.6	41	86	0.0401	122	630	520	450	360

¹⁾ Tolerance -20 %/+40 % at 1 m/s friction speed

²⁾ Type of construction B3 with terminal box

Three-phase motors with squirrel-cage rotor with built-in brake, pole-changing Type of explosion protection – Flameproof enclosure „d/de“ („db/db eb“) for operation in Zone 1 according to EN 60079-0/60079-1

for mains operation, temperature class T4
Version for rated voltage range A according to IEC/EN 60034-1, 50 Hz
With surface cooling, duty type S1, continuous duty
Degree of protection IP 55, thermal class 155

Motor selection data

Type	Output P ₂ kW	Rated current at		Speed n _B rpm	Efficiency η _B %	Power factor cos φ _B -	Starting torque M _A /M _N -	Starting current I _A /I _N -	Motor torque M Nm	Braking torque M _e ¹⁾ Nm	Moment of inertia J kgm ²	Weight m ²⁾ kg	Permissible cyclic duration factor per hour under duty type S4 15, 20, 40 or 60 % c.d.f.			
		I _B 400 V A	I _B 500 V A										FI=1.5 S/h	FI=2 S/h	FI=3 S/h	FI=4 S/h
Synchronous speed 750/1500 rpm – 8/4-pole version																
B82R 90 L8-4	0.4	1.62	1.3	690	57.5	0.62	1.6	2.9	5.7	20	0.0049	38	***)			
	0.6	1.46	1.17	1395	69	0.86	1.6	4.2	4.1							
B82R 90 LX8-4	0.55	2.14	1.71	690	58	0.64	1.6	3	7.7	20	0.0069	42				
	0.8	1.9	1.52	1410	70	0.87	1.8	4.6	5.4							
B82R 100 L8-4	0.9	3	2.4	690	61	0.71	1.8	3.2	12.5	46	0.0098	51	***)			
	1.3	3	2.45	1400	69.5	0.89	1.5	4.2	8.9							
B82R 100 LX8-4	1	3.2	2.55	700	65	0.7	1.8	3.7	13.6	46	0.0138	54				
	1.6	3.6	2.9	1400	71	0.9	1.6	4.5	10.9							
B82R 112 M8-4	1.5	4.4	3.5	700	72	0.69	2	4.4	30.5	46	0.0218	69	***)			
	2.5	5.3	4.25	1390	74.5	0.91	1.9	5	17.1							
B82R 132 S8-4	2.3	6.8	5.4	720	75	0.65	1.8	4.4	30.5	86	0.0353	127	***)			
	3.6	7.2	5.8	1440	81	0.89	1.8	5.4	23.8							
B82R 132 M8-4	3	8.5	6.7	720	78	0.66	2	4.6	40	86	0.0498	138				
	5	9.7	7.8	1440	82.5	0.9	1.9	5.8	33							
Synchronous speed 750/3000 rpm – 8–2-pole version																
B82R 80 K8-2	0.1	0.5	0.4	685	46.5	0.62	1.5	2.3	1.4	10	0.0015	26	***)			
	0.4	1.07	0.86	2870	62.5	0.86	2.3	2.5	1.3							
B82R 80 L8-2	0.14	0.72	0.58	660	43	0.65	1.3	2.5	2	10	0.0019	27				
	0.56	1.58	1.26	2870	60.3	0.85	1.5	2.5	1.9							
B82R 90 L8-2	0.2	0.91	0.73	710	53	0.6	1.5	3	2.7	20	0.0035	38	***)			
	0.8	1.97	1.56	2885	65	0.9	1.4	6	2.6							
B82R 90 LX8-2	0.3	1.29	1.04	710	54	0.62	1.6	3	4	20	0.0058	42				
	1.1	2.5	2	2885	69.3	0.91	1.5	6.2	3.6							
B82R 100 L8-2	0.33	1.42	1.14	715	54	0.62	1.6	3	4.4	46	0.0069	51	***)			
	1.3	2.9	2.3	2885	70	0.92	1.4	6	4.3							
B82R 100 LX8-2	0.4	1.72	1.38	715	54	0.62	1.6	3	5.3	46	0.007	54				
	1.5	3.35	2.65	2885	70.8	0.92	1.5	6	5							
B82R 112 M8-2	0.55	2.1	1.67	715	59.3	0.64	1.5	3.5	7.3	46	0.011	69	***)			
	2.2	4.9	3.95	2920	71	0.9	2	6.9	7.2							
B82R 132 S8-2	0.8	3	2.4	720	59.8	0.65	1.7	3.2	10.6	86	0.0286	127	***)			
	3.2	6.7	5.4	2925	76.6	0.92	2.5	7.2	10.4							
B82R 132 M8-2	1.1	3.65	2.95	720	65.8	0.66	1.8	3	14.6	86	0.037	138				
	4.2	8.3	6.6	2935	78.9	0.93	2.6	7	13.7							

¹⁾ Tolerance -20 %/+40 % at 1 m/s friction speed

²⁾ Type of construction B3 with terminal box

***) upon request

Three-phase motors with Built-on brake

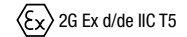

Type of explosion protection – Flameproof enclosure „d/de“ („db/db eb“)
for operation in Zone 1 according to EN 60079-0/60079-1

for mains operation, temperature class T4 ..T5

Version for rated voltage range A according to IEC/EN 60034-1, 50 Hz

With surface cooling, duty type S1, continuous duty

Degree of protection IP 55, thermal class 155

Motor selection data																	
Type	P ₂ kW	I _B		n _B rpm	η _B %	cosφ _B -	M _A /M _N -	I _A /I _N -	M Nm	M _e ¹⁾ Nm		J kgm ²	m ²⁾ kg	Fl=1.5 S/h	Fl=2 S/h	Fl=3 S/h	Fl=4 S/h
		400 V A	500 V A							10	10						
Synchronous speed 3000 rpm – 2-pole version																	
K82R 80 K2	0.75	1.74	1.39	2790	74	0.84	2.7	4.8	2.57	10	10	0.00083	39	upon request			
K82R 80 L2	1.1	2.4	1.92	2820	78	0.85	2.7	5.5	3.73	10	10	0.00105	40				
K82R 90 L2	1.5	3.15	2.55	2840	78.5	0.87	2.7	5.5	5	20	11	0.00155	46				
K82R 90 LX2	2.2	4.4	3.5	2850	83	0.87	2.7	5.6	7.4	20	11	0.00205	50				
K82R 100 L2	3	5.9	4.7	2850	85	0.87	2.7	6.8	10.1	50	13	0.00505	74				
K82R 112 M2	4	7.7	6.1	2880	85.5	0.88	2.3	6.5	13.3	50	13	0.00725	82				
K82R 132 S2	5.5	10.4	8.3	2880	87	0.88	2.5	6.4	18.2	50	13	0.01105	124				
K82R 132 SX2	7.5	13.8	11.1	2910	88	0.89	2.7	6.8	24.6	100	16	0.01465	129				
K82R 160 M2	11	20	16	2925	89	0.89	2.8	6.6	36	150	19	0.0445	192				
K82R 160 M2	15	26.50	21	2920	89.5	0.92	2.8	6.8	49	150	19	0.0555	202				
K82R 160 L2	18.5	32.1	25.5	2925	90.5	0.92	2.6	6.8	60	150	19	0.0645	217				
K82R 180 M2	22	37.50	30.00	2925	91.5	0.92	2.5	6.9	72	150	19	0.0875	225				
K82R 180 L2	30	52	42	2955	92.5	0.9	2.6	7.2	97	270	24	0.1425	284				
K82R 200 L2	37	63	50	2955	93.3	0.91	2.7	7.2	120	270	24	0.1725	307				
Synchronous speed 1500 rpm – 4-pole version																	
K82R 80 K4	0.55	1.36	1.09	1380	73	0.8	2	3.8	3.8	10	10	0.00117	39	1340	1010	670	500
K82R 80 L4	0.75	1.81	1.45	1400	75.5	0.79	2.1	4.5	5.1	10	10	0.00155	40	1340	1010	670	500
K82R 90 L4	1.1	2.5	1.99	1400	77	0.83	2.1	4.8	7.5	10	11	0.0024	46	230	170	110	90
K82R 90 LX4	1.5	3.25	2.65	1405	79	0.82	2.3	5	10.2	20	11	0.0032	51	270	200	135	100
K82R 100 L4	2.2	4.8	3.8	1420	81	0.82	2.4	5.4	14.8	50	13	0.0049	66	235	175	120	90
K82R 100 LX4	3	6.3	5.1	1415	82.5	0.83	2.3	5.5	20.2	50	13	0.0078	83	110	80	55	45
K82R 112 M4	4	8.1	6.5	1435	85	0.84	2.7	6.8	26.6	50	13	0.013	97	220	165	110	85
K82R 132 S4	5.5	10.7	8.6	1440	87	0.85	2.5	6.2	36.5	50	13	0.025	142	150	110	75	55
K82R 132 M4	7.5	14.3	11.4	1440	88.2	0.86	2.7	6.5	50	100	16	0.033	152	140	105	70	50
K82R 160 M4	11	21	16.7	1460	89.5	0.85	2.5	6.6	72	100	19	0.06	210	95	70	50	35
K82R 160 L4	15	28	22.5	1455	90	0.86	2.8	6.5	98	150	19	0.092	251	60	45	30	25
K82R 180 M4	18.5	34.5	27.5	1460	91	0.85	2.9	6.6	121	150	19	0.143	243	70	50	35	25
K82R 180 L4	22	41	32.5	1460	91.5	0.85	3	6.9	144	270	24	0.168	277	60	45	30	20
K82R 200 L4	30	53	42.5	1460	92.5	0.88	2.6	6.8	196	270	24	0.26	344	40	50	20	15
Synchronous speed 1000 rpm – 6-pole version																	
K82R 80 K6	0.37	1.12	0.9	925	67	0.71	2.5	4.1	3.8	10	10	0.0012	39	1260	945	630	470
K82R 80 L6	0.55	1.6	1.28	925	69	0.72	2.4	4	5.7	10	10	0.0028	40	540	400	270	200
K82R 90 L6	0.75	2.15	1.72	910	67	0.75	1.8	3.4	7.9	10	11	0.0036	46	420	310	210	150
K82R 90 LX6	1.1	3.05	2.45	920	71	0.73	2	3.7	11.4	20	11	0.0049	51	560	420	280	210
K82R 100 L6	1	3.75	3	945	77	0.75	2.4	5	15.2	20	13	0.0098	68	44	330	220	165
K82R 112 M6	2.2	5.2	4.2	950	81	0.75	2.7	5.6	22.1	50	13	0.02	97	240	180	120	90
K82R 132 S6	3	6.6	5.3	965	84	0.78	2.7	6.3	29.7	50	13	0.034	142	170	130	85	54
K82R 132 M6	4	8.6	6.9	960	85	0.79	2.6	6	40	50	13	0.04	164	240	180	120	90
K82R 132 MX6	5.5	11.4	9.1	960	86	0.81	2.6	6.4	55	100	16	0.046	152	220	165	110	80
K82R 160 M6	7.5	14.7	11.7	960	86.8	0.85	2.5	6.8	75	100	19	0.09	212	290	220	145	110
K82R 160 L6	11	21	16.9	965	87.5	0.86	2.5	6.7	109	150	19	0.13	257	160	120	80	60
K82R 180 L6	15	28.5	23	965	90	0.84	2.4	6.9	148	270	24	0.2	285	130	100	65	50
K82R 200 L6	18.5	35	28	975	90.5	0.84	1.9	6.2	181	270	24	0.29	340	90	65	45	35
K82R 200 LX6	22	41	33	970	91	0.85	2.2	6.8	217	270	24	0.32	350	80	60	40	30
Synchronous speed 750 rpm – 8-pole version																	
K82R 80 K8	0.18	0.66	0.52	690	61	0.65	3.2	2.2	2.5	10	10	0.0021	39	960	720	480	360
K82R 80 L8	0.25	0.91	0.73	690	62	0.64	3.2	2.2	3.5	10	10	0.0028	40	720	540	360	270
K82R 90 L8	0.37	1.3	1.04	690	63	0.65	3	1.8	5.1	10	11	0.0036	46	560	420	280	210
K82R 90 LX8	0.55	1.85	1.48	690	67	0.64	3.1	1.8	7.6	10	11	0.0049	51	530	400	265	200
K82R 100 L8	0.75	2.3	1.85	710	71	0.66	4	2.4	10.1	20	13	0.0083	65	500	375	250	190
K82R 100 LX8	1.1	3.15	2.5	695	69	0.73	3.8	2	15.1	20	13	0.0098	68	700	530	350	260
K82R 112 M8	1.5	4.15	3.3	710	78	0.67	4.6	2.2	20.2	50	13	0.019	97	620	465	310	230
K82R 132 S8	2.2	5	4	695	80	0.79	4.1	2	30	50	13	0.031	139	230	170	115	90
K82R 132 M8	3	6.9	5.6	705	81	0.77	4.6	2.4	41	50	13	0.038	152	240	180	120	90
K82R 160 M8	4	8.7	7	715	85	0.78	4.6	1.8	53	100	19	0.073	201	150	110	75	55
K82R 160 MX8	5.5	12	9.6	720	86	0.77	5.4	2.1	73	100	19	0.107	212	145	110	70	55
K82R 160 L8	7.5	16.3	13	720	86.5	0.77	5.6	2.2	99	150	19	0.149	257	145	110	70	55
K82R 180 L8	11	22.5	18.1	725	89	0.79	6.4	2.4	145	270	24	0.23	285	200	150	100	75
K82R 200 L8	15	31	24	730	89.5	0.8	6.9	2.4	196	270	24	0.41	350	100	75	50	35

¹⁾ Certificate no. for all brakes BVS No. 81.001, marking Ex de IIC T5

²⁾ Type of construction B3 with terminal box

Coil data for built-in brake (version II2G Ex de II (B+H2)T4)

Size	Voltage	Current	Resistance	Voltage	Current
Motor	U = [V]	I = [A]	R _{min} [Ω]	U ~ [V]	I ~ [A]
80	24	1.09	22	-	-
	103	0.29	369	230	0.46
	130	0.23	567	290	0.36
	176	0.19	910	400	0.3
90	24	1.5	16	-	-
	103	0.36	290	230	0.57
	130	0.35	376	290	0.55
	176	0.26	684	400	0.41
100 and 112	24	1.85	13	-	-
	103	0.42	244	230	0.66
	130	0.35	376	290	0.55
	176	0.31	575	400	0.49
132	24	2.93	8.58	-	-
	130	0.56	232	290	0.88
	176	0.49	360	400	0.77

Coil data for built-on brake (version II2G Ex de IIC T5)

Size	Moment	Voltage	Current	Resistance	Voltage	Current
Brake	M [V]	U = [V]	I = [A]	R _{min} [Ω]	U ~ [V]	I ~ [A]
10/11	10 or 20	24	2.1	11.6	-	-
		98	0.55	177	110	0.61
		205	0.27	770	230	0.3
		215	0.225	954	240	0.25
		258	0.21	1197	270	0.23
		356	0.14	2571	400	0.16
13/16	50 or 100	24	2.93	8.2	-	-
		98	0.8	122.4	110	0.89
		205	0.39	536	230	0.44
		215	0.346	621	240	0.38
		258	0.31	838	270	0.34
		356	0.2	1685	400	0.24
19/24	150 or 270	24	3.08	7.8	-	-
		98	0.85	116	110	0.94
		205	0.4	516	230	0.45
		215	0.4	538	240	0.44
		356	0.25	1438	400	0.28

Bearings

Version IE1 (K82R .../B82R ...)

Size	Pole number	D-end bearing		N-end bearing	
		Standard Fixed bearing for all types of construction	Reinforced bearing	Standard Floating bearing for all types of construction	Insulated bearing
K82R 63	2, 4	6202 2Z	---	6004 2Z	
K82R 71	2, 4, 6, 8	6202 2Z	---	6004 2Z	
K82R 80	2, 4, 6, 8	6204 2Z	---	6204 2Z	
K82R 90	2, 4, 6, 8	6205 2Z	---	6205 2Z	
K82R 100	2, 4, 6, 8	6206 2Z C3	NU 206	6206 2Z C3	6206 C3 VL 2071
K82R 112	2, 4, 6, 8	6306 2Z C3	NU 306	6206 2Z C3	6206 C3 VL 2071
K82R 132	2, 4, 6, 8	6308 2Z C3	NU 308	6308 2Z C3	6308 C3 VL 2071
K82R 160	2, 4, 6, 8	6309 2Z C3	NU 309	6309 2Z C3	6309 C3 VL 2071
K82R 180	2, 4, 6, 8	6310 2Z C3	NU 310	6310 2Z C3	6310 C3 VL 2071
K82R 200	2, 4, 6, 8	6312 2Z C3	NU 312	6312 2Z C3	6312 C3 VL 2071
K82R 225	2, 4, 6, 8	6313 2Z C3	NU 313	6313 2Z C3	6313 C3 VL 2071
K82R 250	2, 4, 6, 8	6315 2Z C3	NU 315	6313 2Z C3	6313 C3 VL 2071
K82R 280	2, 4, 6, 8	6316 2Z C3	NU 316	6315 2Z C3	6315 C3 VL 2071
K82R 315	2	6316 C3	NU 316	6316 C3	6316 C3 VL 2071
K82R 315	4, 6, 8	6318 C3	NU 318	6316 C3	6316 C3 VL 2071
K82R 355	2	6318 C3	NU 318	6318 C3	6318 C3 VL 2071
K82R 355	4, 6, 8	6320 C3	NU 320	6318 C3	6318 C3 VL 2071
			Type of construction V1, V3 only		
K82R 400	2	6318 C3	7318 B	NU 318	6318 C4
K82R 400	4, 6, 8	6322 C3	7322 B	NU 322	6320 C3
K82R 450	2	6318 C3	7318 B	NU 318	6318 C4
K82R 450	4, 6, 8	6324 C3	7324 B	NU 324	6322 C3

Version IE2, IE3 and MEPS (K82R ... Y2/Y3/Y/B82R ... Y2/Y3/Y)

Size	Pole number	D-end bearing		N-end bearing	
		Standard	Reinforced bearing	Standard	Insulated bearing
K82R 80	2, 4, 6, 8		---	6205 2Z	
K82R 90	2, 4, 6, 8	6206 2Z C3	---	6206 2Z C3	
K82R 100	2, 4, 6, 8	6306 2Z C3	NU 306	6206 2Z C3	
K82R 112	2, 4, 6, 8	6308 2Z C3	NU 308	6308 2Z C3	
K82R 132	2, 4, 6, 8	6308 2Z C3	NU 308	6308 2Z C3	
K82R 160	2, 4, 6, 8	6309 2Z C3	NU 309	6309 2Z C3	
K82R 180	2, 4, 6, 8	6310 2Z C3	NU 310	6310 2Z C3	
K82R 200	2, 4, 6, 8	6312 2Z C3	NU 312	6312 2Z C3	
K82R 225	2, 4, 6, 8	6313 2Z C3	NU 313	6313 2Z C3	
K82R 250	2, 4, 6, 8	6315 2Z C3	NU 315	6313 2Z C3	
K82R 280	2, 4, 6, 8	6316 2Z C3	NU 316	6315 2Z C3	
K82R 315	2	6316 C3	NU 316	6316 C3	6316 C3 VL 2071
K82R 315	4, 6, 8	6318 C3	NU 318	6316 C3	6316 C3 VL 2071
K82R 355	2	6318 C3	NU 318	6318 C3	6318 C3 VL 2071
K82R 355	4, 6, 8	6320 C3	NU 320	6318 C3	6318 C3 VL 2071

Version MEPS (K82R ... XY/B82R ... XY)

Size	Pole number	D-end bearing		N-end bearing	
		Standard	Reinforced bearing	Standard	Insulated bearing
K82R 250S	2, 4, 6, 8	6315 2Z C3	NU 315	6313 2Z C3	
K82R 250M	2, 4, 6, 8	6316 2Z C3	NU 316	6315 2Z C3	
K82R 280S	2, 4, 6, 8	6316 2Z C3	NU 316	6315 2Z C3	
K82R 280M	2	6316 C3	NU 316	6316 C3	6316 C3 VL 2071
K82R 280M	4, 6, 8	6318 C3	NU 318	6316 C3	6316 C3 VL 2071
K82R 315	2	6316 C3	NU 316	6316 C3	6316 C3 VL 2071
K82R 315	4, 6, 8	6318 C3	NU 318	6316 C3	6316 C3 VL 2071

Type of explosion protection – Flameproof enclosure „d/de“ („db/db eb“)

Bearing arrangement

D-end bearing

N-end bearing

D-end bearing

N-end bearing

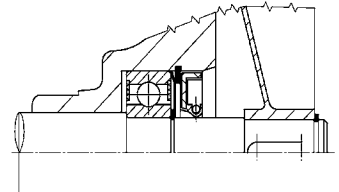
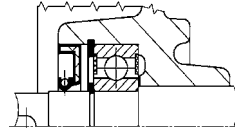
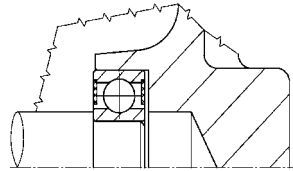
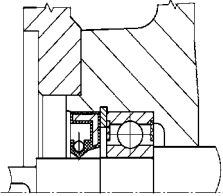

Size 63

Size 71

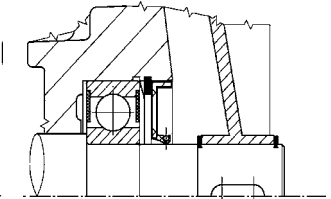
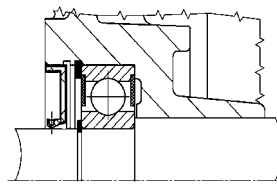
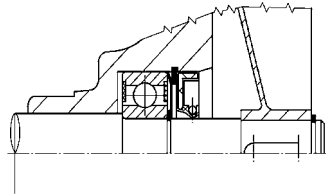
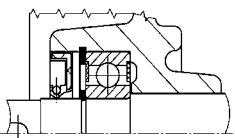

Size 80-132

Size 160

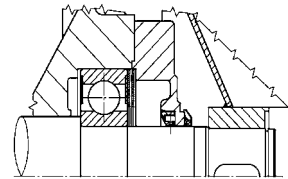
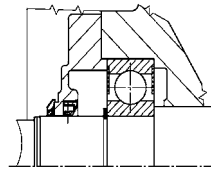
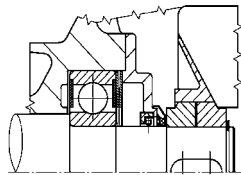
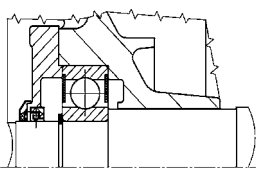

Size 180-200

Size 225

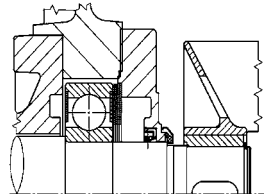
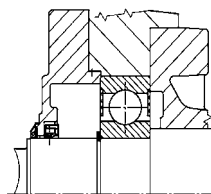
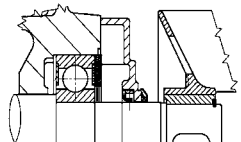
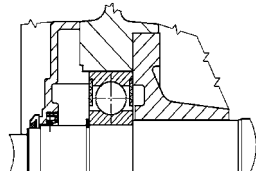

Size 250

Size 280

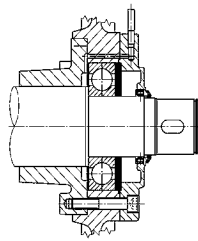
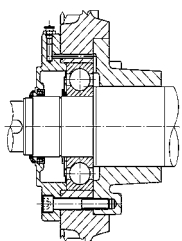

Size 315-450

Illustrations without obligation

Terminal boxes

Explosion protected motors, Type of explosion protection – Flameproof enclosure „d/de“ („db/db eb“)

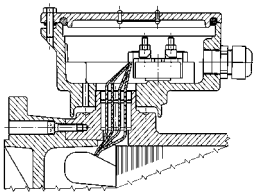

Size 63 – 112

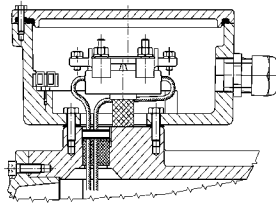

Size 132 – 160

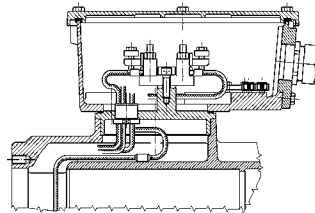

Size 180 – 280
Size 315 with stud bushing

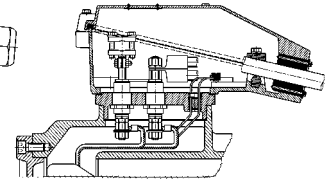

Size 250 – 450
Size 250 + 280 with
terminal plate
as size 180 – 280

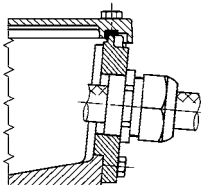

Version 1
Cable entry according to
EN 60079-7
(compression gland)
for entry of fixed cables

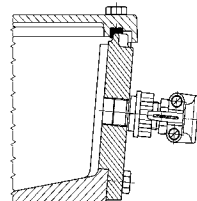

Version 3
Cable entry gland according to
EN 60079-7,
with strain relief and twist/kink
protection for cables of mobile
equipment

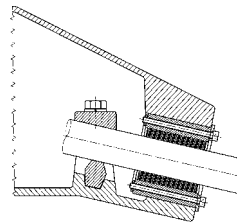

Version 9
Divided terminal box with internal strain relief,
cable entry according to EN 60079-7

Mains cable entry to Ex e („eb“) terminal boxes

Ver- sion	Size	63	71	80	90	100	112	132	160	180	200	225	250	280	315	355	400–450
1	Thread	1 x M25 x 1.5			1 x M32 x 1.5			1 x M40 x 1.5	1 x M50 x 1.5	1 x M63 x 1.5		not available					
	for cable Outer diameter-Ø mm	13–19			12–21			17–28	21–35	27–48		not available					
3	Thread	1 x M25 x 1.5			1 x M32 x 1.5			1 x M40 x 1.5	1 x M50 x 1.5	1 x M63 x 1.5		1 x M80 x 2	1 x M90 x 2				
	for cable Outer diameter-Ø mm	11–16			15–20			19–27	26–34	35–46		62–68	74–80				
9	for cable Outer diameter-Ø mm	not available										1 x Ø 48–70 2 x Ø 26–48		1 x Ø 48–70 2 x Ø 48–70			

Normal version

Terminal boxes in normal version Ex e („eb“) IIC

The terminal boxes of low-voltage motors are supplied with metric threads, with assignments according to DIN 42 925 and cable glands according to EN 50262, certified to EN 60079-7.

From size 180, they are provided with a detachable screwed plate to accommodate either threaded compression glands or conductor glands. From size 250, longitudinally divided terminal boxes are also available.

An additional terminal box for thermal monitoring or space heating can be supplied upon request for motors from size 132. The additional box is screwed onto the motor terminal box, except for sizes 355 to 450, where it is mounted on the housing.

Suitable cross-sections for Ex e („eb“) IIC for low voltage

Size	Rated cross-section max. [mm ²]	Rated current max. [A]	Terminal type	No. of terminals	Terminal thread
36–112	4	25	U-clamp terminal ²⁾	6	M5
132, 160	10	63	U-clamp terminal ²⁾	6	M6
180–225	70	100	Tab terminal ²⁾	6	M8
250–280	120	250	Tab terminal ²⁾	6	M12
315	150	315 ¹⁾	Round terminal ²⁾	6	M12
355–450	300	400 ¹⁾	Round terminal ²⁾	6	M16
355–450	400	630 ¹⁾	Universal terminal ³⁾	6	M16

¹⁾ Material Cu

²⁾ Suitable for connection with and without cable lug

³⁾ Suitable for connection with cable lug

Terminal boxes for Ex d („db“) IIC for low voltage

The terminal boxes comply with the stipulations for explosion protection type Ex “d” (“db”) according to EN 60079.

In the normal version, they are provided with a threaded hole according to ISO DIN 13.

Upon request, they can also be supplied with the thread version specified in the bottom table. The required thread dimensions must be specified in the order.

Note: Cable entry components for explosion protection type Ex “d” (“db”) IIC must also comply with EN 60079-1 and must be certified accordingly. These components are not included in the scope of delivery.

Cable entry threads for Ex d („db“) terminal boxes for low-voltage motors

Size	63	71	80	90	100	112	132	160	180	200	225	250	280	315	400–450
Thread version ISO-DIN 13	1 x M25 x 1.5				1 x M32 x 1.5			1 x M40 x 1.5		1 x M50 x 1.5		1 x M63 x 1.5			1 x M80 x 2
NEMA version NPT	¾"				1"			1¼"		1½"		2"			3"

For thermal monitoring: For all versions additionally 1 x M25 x 1.5 and 1 x ½"

Motors in type of explosion protection – Flameproof enclosure „d/de“ („db/db eb“)

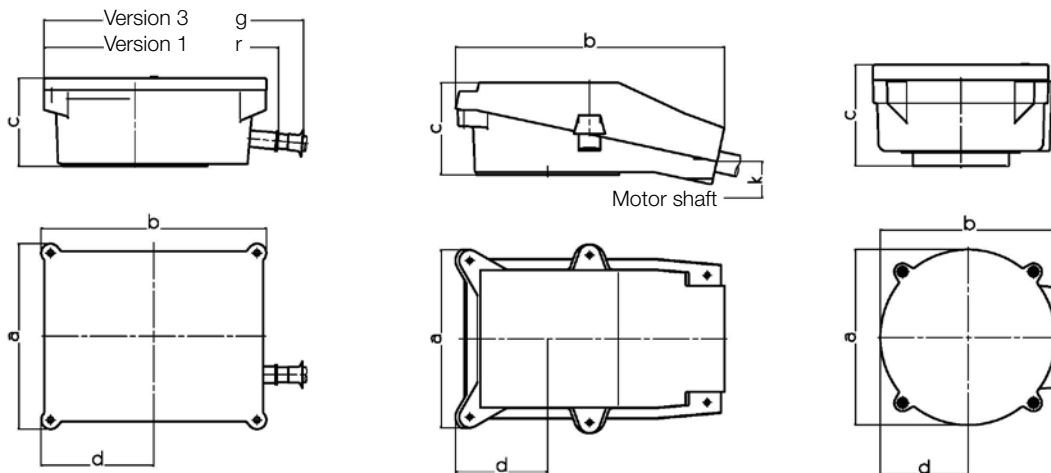

Protection type Cable entry Size Connection space	EAR – Ex e Version 1 and 3						CAR – Ex d Without cable gland						
	a	b	c	d	r	g	Size Connection space	a	b	c	d		
63	EAR 80	145	145	88	53	179	185	63	CAR 80	145	145	92	53
71	EAR 80	145	145	88	53	179	185	71	CAR 80	145	145	92	53
80	EAR 80	145	145	88	53	179	185	80	CAR 80	145	145	92	53
90	EAR 80	145	145	88	53	179	185	90	CAR 80	145	145	92	53
100	EAR 80	145	145	88	53	185	200	100	CAR 80	145	145	92	53
112	EAR 80	145	145	88	53	185	200	112	CAR 80	145	145	92	53
132	EAR 132	220	220	117	110	260	275	132	CAR 132	220	220	103	110
160	EAR 132	220	220	117	110	265	281	160	CAR 132	220	220	103	110
180	EAR 180	280	340	152	140	385	401	180	CAR 180	265	270	162	133
200	EAR 180	280	340	152	140	390	420	200	CAR 180	265	270	162	133
225	EAR 180	280	340	154	140	390	420	225	CAR 225	380	380	202	190
250	EAR 250	340	422	206	161	474	512	250	CAR 225	380	380	202	190
280	EAR 250	340	422	206	161	474	512	280	CAR 225	380	380	202	190
315	EAR 250	340	422	198	161	474	512	315	CAR 315	380	380	208	190
355	EAR 355	480	527	249	224	---	617	355	CAR 355	484	734	335	242
400	EAR 355	480	527	249	224	---	630	400	CAR 355	484	734	335	242
450	EAR 355	480	527	249	224	---	630	450	CAR 355	484	734	335	242

Protection type Cable entry Size Connection space	EAR – Ex e Version 9					
	a	b	c	d	k	
250	EAR 250	356	512	186	179	317
280	EAR 250	356	512	186	179	357
315	EAR 250	356	512	186	179	427
355	EAR 355	425	650	254	213	541
400	EAR 355	425	650	254	213	558
450	EAR 355	425	650	254	213	626

Protection type Cable entry Type CD...XY* Connection space	EAR – Ex e Version 1 and 3						CAR – Ex d without cable gland						
	a	b	c	d	r	g	Size Connection space	a	b	c	d		
250S	EAR 250	340	422	196	161	474	512	250S	CAR 225	380	380	202	190
250M	EAR 250	340	422	196	161	474	512	250M	CAR 225	380	380	202	190
280S	EAR 250	340	422	196	161	474	512	280S	CAR 225	380	380	202	190
280M	EAR 250	340	422	196	161	474	512	280M	CAR 315	380	380	208	190
315	EAR 250	340	422	196	161	474	512	315	CAR 315	380	380	208	190

Dimensions

Three-phase motors with squirrel-cage rotor for operation in Zone 1 according to EN 60079-1
 Type of explosion protection – Flameproof enclosure „d/de“ („db/db eb“),
 High- and Premium Efficiency IE2, IE3

with surface cooling with radial fan, type of cooling IC 411

Type of construction IM B3, IM B6, IM B7,
 IM B8, IM V5¹⁾, IM V6

Type	A	AA	AB	AC	B	BA	BB	BC	C	H _{-0.5}	HA	HD	K _{H17}	K' _{H17}	L Pole number			
															2	4	6	8
IE.-K82R...																		
80 M	125	35	160	158	100	37	130	15	50	80	12	271	Ø 10	-	343	343	-	-
90 S	140	38	180	178	100	44	130	15	56	90	12	295	Ø 10	-	398	398	398	-
90 L	140	40	180	183	125	44	155	15	56	90	12	295	Ø 10	-	398	398	398	-
100 L	160	42	200	198	140	46	175	17.5	63	100	15	311	Ø 12	-	419	419	419	419
112 M	190	45	235	218	140	46	175	17.5	70	112	17	337	Ø 12	-	517	517	517	517
132 S	216	60	266	265	140	60	187	23.5	89	132	20	411	Ø 12	-	-	529	529	529
132 S1	216	60	266	265	140	60	187	23.5	89	132	20	411	Ø 12	-	529	-	-	-
132 S2	216	60	266	265	140	60	187	23.5	89	132	20	411	Ø 12	-	579	-	-	-
132 M	216	60	266	265	178	60	225	23.5	89	132	20	411	Ø 12	-	-	579	-	579
132 M1	216	60	266	265	178	60	225	23.5	89	132	20	411	Ø 12	-	-	-	529	-
132 M2	216	60	266	265	178	60	225	23.5	89	132	20	411	Ø 12	-	-	-	579	-
K82R...Y2/Y3/Y																		
160 M	254	65	310	318	210	100	300	23	108	160	25	477	15	20	713	676	676	676
160 LY2	254	65	310	318	254	100	300	23	108	160	25	477	15	20	713	676	676	-
160 LY3/Y	254	65	310	318	254	100	300	23	108	160	25	477	15	20	713	711	711	676
180 M	279	75	350	353	241	100	340	30	121	180	25	545	15	20	726	726	-	-
180 LY2	279	75	350	353	279	100	340	30	121	180	25	545	15	20	-	726	726	-
180 LY3/Y	279	75	350	353	279	100	340	30	121	180	25	545	15	20	-	776	726	726
200 L	318	80	390	393	305	90	365	30	133	200	30	581	20	26	789	789	789	789
K82R...Y2/Y3/Y																		
225 S	356	85	450	455	286	90	370	29.5	149	225 _{-0.5}	35	634	20	26	-	937	-	888
225 M	356	85	450	455	311	90	370	29.5	149	225 _{-0.5}	35	634	20	26	907	937	888	888
250 M	406	105	510	493	349	110	420	35.5	168	250 _{-0.5}	40	731	26	35	1000	1000	934	934
280 S	457	110	570	548	368	120	500	40.5	190	280 ₋₁	45	802	26	35	1109	1109	1109	1109
280 M	457	110	570	548	419	120	500	40.5	190	280 ₋₁	45	802	26	35	1109	1109	1109	1109
315 S	508	150	630	635	406	210	615	53	216	315 ₋₁	40	897	39	30	1268	1298	1218	1218
315 M	508	150	630	635	457	210	615	53	216	315 ₋₁	40	897	39	30	1268	1298	1218	1218
315 L1	508	150	630	635	508	210	615	53	216	315 ₋₁	40	897	39	30	1268	1298	1218	1218
315 L2	508	150	630	635	508	210	615	53	216	315 ₋₁	40	897	39	30	1468	1498	1418	1498
315 L3	508	150	630	635	508	210	615	53	216	315 ₋₁	40	897	39	30	1468	1498	1418	1498
355 M	610	180	720	725	560	220	720	45	254	355 ₋₁	50	1084	30	39	-	-	1597	1597
K82R ... XY2/XY3/XY****																		
250 S	406	110	510	493	311	110	420	30	168	250 _{-0.5}	45	731	Ø 26.5	-	1000	1000	934	934
250 M	406	110	510	548	349	110	420	30	168	250 _{-0.5}	45	762	Ø 26.5	-	1109	1109	1109	1109
280 S	457	110	570	548	368	120	500	40.5	190	280 ₋₁	45	802	26	35	1109	1109	1109	1109
280 M	457	110	570	635	419	-	570	40	190	280 ₋₁	48	862	Ø 26.5	-	1268	1298	1218	1218
315 S	508	150	630	635	406	210	615	53	216	315 ₋₁	40	897	39	30	1268	1298	1218	1218
315 M	508	150	630	635	457	210	615	53	216	315 ₋₁	40	897	39	30	1268	1298	1218	1298
315 L1	508	150	630	635	508	210	615	53	216	315 ₋₁	40	897	39	30	1468	1498	1218	1298
315 L2	508	150	630	635	508	210	615	53	216	315 ₋₁	40	897	39	30	1468	1498	1418	1498

Lifting eye bolts from size 90.
 Dimension AC measured over screw head.
 Dimension HD refers to terminal box Ex "e".
 Terminal box can be rotated by 4 x 90°.

¹⁾ Type of construction IM V5 with protective canopy.

²⁾ For type 250 to 400-4, 6, 8: Specifications for 2 poles apply for dimensions DA, EA, GC, FA, DC.
 For type 450-6, 8: Specifications for 4 poles apply for dimensions EA, GC, FA, DC.

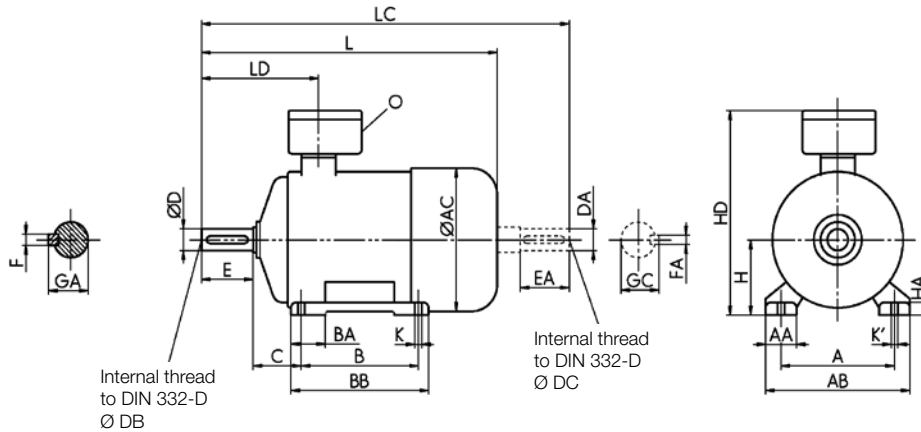

Type	LC			LD		Ø	Shaft end			E, EA		GA, GC		F, FA		DB, DC	
(IE-)K82R...	Pole number			Pole number			D, DA										
	2	4	6, 8														
80 M	417	417	-	127		2 x M25 x 1.5	19 _{f6}		40		21.5		6		M6		
90 S	479	479	479	139		2 x M25 x 1.5	24 _{f6}		50		27		8		M8		
90 L	479	479	479	139		2 x M25 x 1.5	24 _{f6}		50		27		8		M8		
100 L	515	515	515	154		2 x M32 x 1.5	28 _{f6}		60		31		8		M10		
112 M	608	608	608	189		2 x M32 x 1.5	28 _{f6}		60		31		8		M10		
132 S	645	645	645	226		2 x M32 x 1.5	38 _{k6}		80		41		10		M12		
132 S1	645	-	-	226		2 x M32 x 1.5	38 _{k6}		80		41		10		M12		
132 S2	652	-	-	226		2 x M32 x 1.5	38 _{k6}		80		41		10		M12		
132 M	-	652	645*	226		2 x M32 x 1.5	38 _{k6}		80		41		10		M12		
132 M1	-	-	645**	226		2 x M32 x 1.5	38 _{k6}		80		41		10		M12		
132 M2	-	-	652**	226		2 x M32 x 1.5	38 _{k6}		80		41		10		M12		

K82R Y2,Y3,Y

160 M	864	864	864	261		2 x M40 x 1.5	42 _{k6}		110		45		12		M16	
160 LY2	864	864	864**	261		2 x M40 x 1.5	42 _{k6}		110		45		12		M16	
160 LY3/Y	864	899	***	261		2 x M40 x 1.5	42 _{k6}		110		45		12		M16	
180 M	909	909	-	369		2 x M40 x 1.5	48 _{k6}		110		51.5		14		M16	
180 LY2	-	909	909**	369		2 x M40 x 1.5	48 _{k6}		110		51.5		14		M16	
180 LY3/Y	-	959	909	369		2 x M40 x 1.5	48 _{k6}		110		51.5		14		M16	
200 L	983	983	983	390		2 x M50 x 1.5	55 _{m6}		110		59		16		M20	

Type	LC			LD		Ø	Shaft end			E, EA ²⁾		GA, GC ²⁾		F, FA ²⁾		DB, DC ²⁾		
K82R...	Pole number			Pole number			D _{m6} ¹⁾ , DA _{m6} ²⁾											
Y2/Y3/Y	2	4	6, 8	2	4, 6, 8		2	4	6, 8	2	4, 6, 8	2	4	6, 8	2	4, 6, 8	2	4, 6, 8
225 S	-	1175	1175	-	377	2 x M50 x 1.5	-	60	60	-	140	-	64	64	-	18	-	M20
225 M	1145	1175	1175	347	377	2 x M50 x 1.5	55	60	60	110	140	59	64	64	16	18	M20	M20
250 M	1250	1250	1250	482	482	2 x M63 x 1.5	60	65	65	140	140	64	69	69	18	18	M20	M20
280 S	1375	1375	1375	483	483	2 x M63 x 1.5	65	75	75	140	140	69	79.5	79.5	18	20	M20	M20
280 M	1375	1375	1375	483	483	2 x M63 x 1.5	65	75	75	140	140	69	79.5	79.5	18	20	M20	M20
315 S	1543	1573	1573	496	526	2 x M63 x 1.5	65	80	80	140	170	69	85	85	18	22	M20	M20
315 M	1543	1573	1573	496	526	2 x M63 x 1.5	65	80	80	140	170	69	85	85	18	22	M20	M20
315 L1	1543	1573	1573	496	526	2 x M63 x 1.5	65	80	80	140	170	69	85	85	18	22	M20	M20
315 L2	1743	1773	1773	496	526	2 x M63 x 1.5	65	80	80	140	170	69	85	85	18	22	M20	M20
315 L3	1743	1773	1773	496	526	2 x M63 x 1.5	65	80	80	140	170	69	85	85	18	22	M20	M20
355 M	-	-	1980	-	702	2 x M80 x 2	75	90	90	140	170	79.5	95	95	20	25	M20	M24

Type	LC			LD		Ø	Shaft end			E, EA ²⁾		GA, GC ²⁾		F, FA ²⁾		DB, DC		
CD...	Pole number			Pole number			D _{m6} ¹⁾ , DA _{m6} ²⁾											
XY2/XY3	2	4	6, 8	2	4, 6, 8		2	4	6, 8	2	4, 6, 8	2	4	6, 8	2	4, 6, 8	2	4, 6, 8
250 S	1250	1250	1250	482	482	2 x M63 x 1.5	60	65	65	140	140	64	69	69	18	18	M20	M20
250 M	1375	1375	1375	483	483	2 x M63 x 1.5	60	65	65	140	140	64	69	69	18	18	M20	M20
280 S	1375	1375	1375	483	483	2 x M63 x 1.5	65	75	75	140	140	69	79.5	79.5	18	20	M20	M20
280 M	1543	1573	1573	496	526	2 x M63 x 1.5	65	75	75	140	140	69	79.5	79.5	18	20	M20	M20
315 S	1543	1573	1573	496	526	2 x M63 x 1.5	65	80	80	140	170	69	85	85	18	22	M20	M20
315 M	1543	1573	1573	496	526	2 x M63 x 1.5	65	80	80	140	170	69	85	85	18	22	M20	M20
315 L1	1743	1773	1773	496	526	2 x M63 x 1.5	65	80	80	140	170	69	85	85	18	22	M20	M20
315 L2	1743	1773	1773	496	526	2 x M63 x 1.5	65	80	80	140	170	69	85	85	18	22	M20	M20

For pole-switching motors (4/2, 6/4 and 8/4), the 4-pole shaft end is used.
 Exception: Motors in sizes 355, 400 and 450 with pole-switching configuration 4/2. In this case, the 2-pole shaft end is used.
 The length dimension L corresponds to 4-pole motors for all sizes.

**Three-phase motors with squirrel-cage rotor for operation in Zone 1 according to EN 60079-1
Type of explosion protection – Flameproof enclosure „d/de“ („db/db eb“),
High- and Premium Efficiency IE2, IE3**

with surface cooling with radial fan, type of cooling IC 411

Type of construction IM B5, IM V1¹⁾, IM V3

Type	Mounting flange				S _{H17}	T	AC	AD	L				LC			
	LA	M	N	P					Pole number				Pole number			
IE.-K82R...									2	4	6	8	2	4	6	8
80 M	12	165	130 _{je}	200	12	3.5	158	185	343	343	-	-	417	417	-	-
90 S+L	12	165	130 _{je}	200	12	3.5	178	198	398	398	398	-	479	479	479	-
100 L	16	215	180 _{je}	250	14.5	4	198	205	419	419	419	419	515	515	515	515
112 M	16	215	180 _{je}	250	14.5	4	218	225	517	517	517	517	608	608	608	608
132 S	16	265	230 _{je}	300	14.5	4	265	279	-	529	529	529	-	645	645	645
132 S1	16	265	230 _{je}	300	14.5	4	265	279	529	-	-	-	645	-	-	-
132 S2	16	265	230 _{je}	300	14.5	4	265	279	579	-	-	-	652	-	-	-
132 M	16	265	230 _{je}	300	14.5	4	265	279	-	579	-	529	-	652	-	645
132 M1	16	265	230 _{je}	300	14.5	4	265	279	-	-	529	-	-	-	645	-
132 M2	16	265	230 _{je}	300	14.5	4	265	279	-	-	579	-	-	-	652	-
K82R...Y2/Y3/Y																
160 M	20	300	250 _{je}	350	18.5	5	318	317	713	676	676	676	864	864	864	864
160 LY2	20	300	250 _{je}	350	18.5	5	318	317	713	676	676	-	864	864	864	-
160 LY3/Y	20	300	250 _{je}	350	18.5	5	318	317	713	711	711	676	864	899	899	864
180 M	20	300	250 _{je}	350	18.5	5	353	365	726	726	-	-	909	909	-	-
180 LY2	20	300	250 _{je}	350	18.5	5	353	365	-	726	726	-	-	909	909	-
180 LY3/Y	20	300	250 _{je}	350	18.5	5	353	365	-	776	726	726	-	959	909	909
200 L	20	350	300 _{je}	400	18.5	5	393	381	789	789	789	789	983	983	983	983
K82R... Y2/Y3/Y																
Type	Mounting flange				S _{H17}	T	AC	AD	L				LC			
K82R... Y2/Y3/Y	LA	M	N _{h6}	P					Pole number				Pole number			
									2	4	6	8	2	4	6	8
225 S	22	400	350	450	18.5	5	455	409	-	937	-	888	-	1175	-	1175
225 M	22	400	350	450	18.5	5	455	409	907	937	888	888	1145	1175	1175	1175
250 M	18	500	450	550	18.5	5	493	471	1000	1000	934	934	1250	1250	1250	1250
280 S	18	500	450	550	18.5	5	548	511	1109	1109	1109	1109	1375	1375	1375	1375
280 M	18	500	450	550	18.5	5	548	511	1109	1109	1109	1109	1375	1375	1375	1375
315 S	22	600	550	660	24	6	635	582	1268	1298	1218	1218	1543	1573	1573	1573
315 M	22	600	550	660	24	6	635	582	1268	1298	1218	1218	1543	1573	1573	1573
315 L1	22	600	550	660	24	6	635	582	1268	1298	1218	1218	1543	1573	1573	1573
315 L2	22	600	550	660	24	6	635	582	1468	1498	1418	1498	1743	1773	1773	1773
315 L3	22	600	550	660	24	6	635	582	1468	1498	1418	1498	1743	1773	1773	1773
335 M	25	740	680	800	24	6	725	729	-	-	1597	1597	-	-	1980	1980
K82R ... XY2/XY3/XY****																
250 S	22	500	450	550	18.5	5	493	481	1000	1000	934	934	1250	1250	1184	1184
250 M	22	500	450	550	18.5	5	548	476	1109	1109	1109	1109	1375	1375	1375	1375
280 S	22	500	450	550	18.5	5	548	522	1109	1109	1109	1109	1375	1375	1375	1375
280 M	22	500	450	550	18.5	5	635	582	1268	1298	1218	1218	1543	1573	1573	1573
315 S	22	600	550	660	24	6	635	582	1268	1298	1218	1218	1543	1573	1573	1573
315 M	22	600	550	660	24	6	635	582	1268	1298	1218	1218	1543	1573	1573	1573
315 L1	22	600	550	660	24	6	635	582	1468	1498	1218	1298	1743	1773	1773	1773
315 L2	22	600	550	660	24	6	635	582	1468	1498	1418	1498	1743	1773	1773	1773

¹⁾ Type of construction IM V5 with protective canopy

²⁾ For type 250 to 315-4, 6, 8: Specifications for 2 poles apply for dimensions DA, EA, GC, FA, DC.

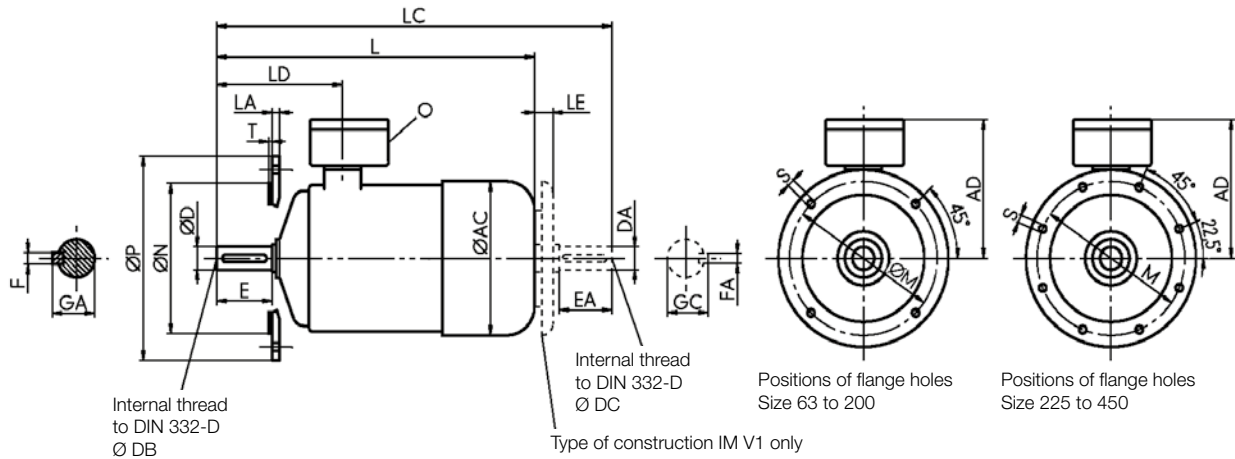

Type	LD	LE			Shaft end	E, EA	GA, GC	F, FA	DB, DC	
		Pole number	0	D, DA						
IE.-K82R...		2	4	6, 8						
80 M	127	25	25	25	2 x M25 x 1.5	19 _{j6}	40	21.5	6	M6
90 S+L	139	25	25	25	2 x M25 x 1.5	24 _{j6}	50	27	8	M8
100 L	154	30	30	30	2 x M32 x 1.5	28 _{j6}	60	31	8	M10
112 M	189	30	30	30	2 x M32 x 1.5	28 _{j6}	60	31	8	M10
132 S+M	226	30	30	30	2 x M32 x 1.5	38 _{k6}	80	41	10	M12

K82R...Y2/Y3/Y

160 M+L	261	66	66	66	2 x M40 x 1.5	42 _{k6}	110	45	12	M16
180 M+L	369	66	66	-	2 x M40 x 1.5	48 _{k6}	110	51.5	14	M16
200 L	390	77	77	77	2 x M50 x 1.5	55 _{m6}	110	59	16	M20

Type	LD	LD			Shaft end	E, EA ²⁾	GA, GC ²⁾	F, FA ²⁾	DB, DC ²⁾									
		Pole number	0	D _{m6} , DA _{m6} ²⁾														
K82R... Y2/Y3/Y	2	4, 6, 8	2	4	6, 8	2	4	6, 8	2	4, 6, 8	2	4, 6, 8	2	4, 6, 8				
225 S	-	377	-	87	87	2 x M50 x 1.5	-	60	60	-	140	-	64	64	-	18	-	M20
225 M	347	377	87	87	87	2 x M50 x 1.5	55	60	60	110	140	59	64	64	16	18	M20	M20
250 M	482	482	94	94	94	2 x M63 x 1.5	60	65	65	140	140	64	69	69	18	18	M20	M20
280 S	483	483	110	110	110	2 x M63 x 1.5	65	75	75	140	140	69	79.5	79.5	18	20	M20	M20
280 M	483	483	110	110	110	2 x M63 x 1.5	65	75	75	140	140	69	79.5	79.5	18	20	M20	M20
315 S	496	526	115	115	115	2 x M63 x 1.5	65	80	80	140	170	69	85	85	18	22	M20	M20
315 M	496	526	115	115	115	2 x M63 x 1.5	65	80	80	140	170	69	85	85	18	22	M20	M20
315 L1	496	526	115	115	115	2 x M63 x 1.5	65	80	80	140	170	69	85	85	18	22	M20	M20
315 L2	496	526	115	115	115	2 x M63 x 1.5	65	80	80	140	170	69	85	85	18	22	M20	M20
315 L3	496	526	115	115	115	2 x M63 x 1.5	65	80	80	140	170	69	85	85	18	22	M20	M20
355 M	-	702	130	130	130	2 x M80 x 2	75	90	90	140	170	79.5	95	95	20	25	M20	M24

K82R ... XY2/XY3/XY

250 S	482	482	94	94	94	2 x M63 x 1.5	60	65	65	140	140	64	69	69	18	18	M20	M20
250 M	483	483	110	110	110	2 x M63 x 1.5	60	65	65	140	140	64	69	69	18	18	M20	M20
280 S	483	483	110	110	110	2 x M63 x 1.5	65	75	75	140	140	69	79.5	79.5	18	20	M20	M20
280 M	496	526	115	115	115	2 x M63 x 1.5	65	75	75	140	140	69	79.5	79.5	18	20	M20	M20
315 S	496	526	115	115	115	2 x M63 x 1.5	65	80	80	140	170	69	85	85	18	22	M20	M20
315 M	496	526	115	115	115	2 x M63 x 1.5	65	80	80	140	170	69	85	85	18	22	M20	M20
315 L1	496	526	115	115	115	2 x M63 x 1.5	65	80	80	140	170	69	85	85	18	22	M20	M20
315 L2	496	526	115	115	115	2 x M63 x 1.5	65	80	80	140	170	69	85	85	18	22	M20	M20

For pole-switching motors (4/2, 6/4 and 8/4), the 4-pole shaft end is used.

Exception: Motors in sizes 355, 400 and 450 with pole-switching configuration 4/2.

In this case, the 2-pole shaft end is used. The length dimension L corresponds to 4-pole motors for all sizes.

Three-phase motors with squirrel-cage rotor for operation in Zone 1 according to EN 60079-1
Type of explosion protection – Flameproof enclosure „d/de“ („db/db eb“),
High- and Premium Efficiency IE2, IE3

with surface cooling with radial fan, type of cooling IC 411

Type of construction IM B5, IM V1¹⁾, IM V3

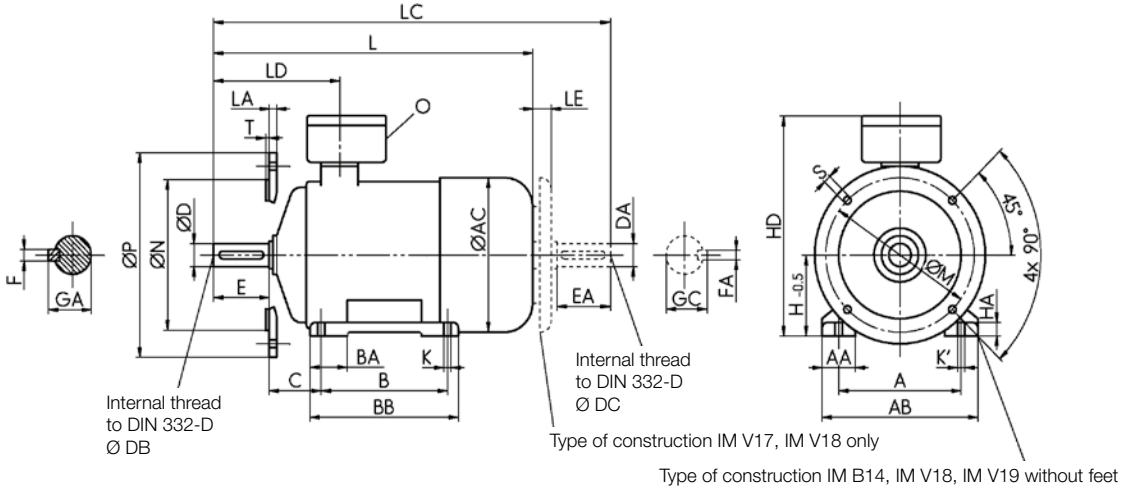

Type	A	AA	AB	AC	B	BA	BB	BC	C	H _{-0.5}	HA	HD	K _{H17}
IE.-K82R...													
80 M	125	35	160	158	100	37	130	15	50	80	12	271	0 10
90 S	140	38	180	178	100	44	130	15	56	90	12	295	0 10
90 L	140	40	180	183	125	44	155	15	56	90	12	295	0 10
100 L	160	42	200	198	140	46	175	17.5	63	100	15	311	0 12
112 M	190	45	235	218	140	46	175	17.5	70	112	17	337	0 12
132 S	216	60	266	265	140	60	187	23.5	89	132	20	411	0 12
132 S1	216	60	266	265	140	60	187	23.5	89	132	20	411	0 12
132 S2	216	60	266	265	140	60	187	23.5	89	132	20	411	0 12
132 M	216	60	266	265	178	60	225	23.5	89	132	20	411	0 12
132 M1	216	60	266	265	178	60	225	23.5	89	132	20	411	0 12
132 M2	216	60	266	265	178	60	225	23.5	89	132	20	411	0 12

Type	L				LC				LE	LD	O
	Pole number				Pole number						
IE.-K82R...	2	4	6	8	2	4	6	8			
80 M	343	343	-	-	417	417	-	-	25	127	2 x M25 x 1.5
90 S+L	398	398	398	-	479	479	479	-	25	139	2 x M25 x 1.5
100 L	419	419	419	419	515	515	515	515	30	154	2 x M32 x 1.5
112 M	517	517	517	517	608	608	608	608	30	189	2 x M32 x 1.5
132 S	-	529	529	529	-	645	645	645	30	226	2 x M32 x 1.5
132 S1	529	-	-	-	645	-	-	-	30	226	2 x M32 x 1.5
132 S2	579	-	-	-	652	-	-	-	30	226	2 x M32 x 1.5
132 M	-	579	-	579	-	652	-	645	30	226	2 x M32 x 1.5
132 M1	-	-	529	-	-	-	645	-	30	226	2 x M32 x 1.5
132 M2	-	-	579	-	-	-	652	-	30	226	2 x M32 x 1.5

Type	D, DA		E, EA		GA, GC		F, FA		DA, DC		Mounting flange			
									LA	M	N _{j6}	P	S	T
IE.-K82R...														
80 M	19 _{j6}	40	21.5	6	M6	10	100	80	120	M6	3			
90 S+L	24 _{j6}	50	27	8	M8	10	115	95	140	M8	3			
100 L	28 _{j6}	60	31	8	M10	12	130	110	160	M8	3.5			
112 M	28 _{j6}	60	31	8	M10	12	130	110	160	M8	3.5			
132 S+M	38 _{k6}	80	41	10	M12	12	165	130	200	M10	3.5			

Mounting flange according to EN 50347, form FT.
 Lifting eye bolts from size 90.
 Dimension AC measured over screw head.
 Dimension HD refers to terminal space Ex "e".
 Terminal space can be rotated by 4 x 90°.

¹⁾ Protective canopy required for type of construction IM V17 and IM V18
²⁾ For pole-switching motors (4/2, 6/4 and 8/4), the 4-pole shaft end is used.
 Exception: Motors in sizes 355, 400 and 450 with pole-switching configuration 4/2.
 In this case, the 2-pole shaft end is used. The length dimension L corresponds to 4-pole motors for all sizes.

**Three-phase motors with squirrel-cage rotor for operation in Zone 1 according to EN 60079-1
Type of explosion protection – Flameproof enclosure „d/de“ („db/db eb“), Standard Efficiency IE1**

with surface cooling with radial fan, type of cooling IC 411

Type of construction IM B3, IM B6, IM B7, IM B8, IM V5¹⁾, IM V6

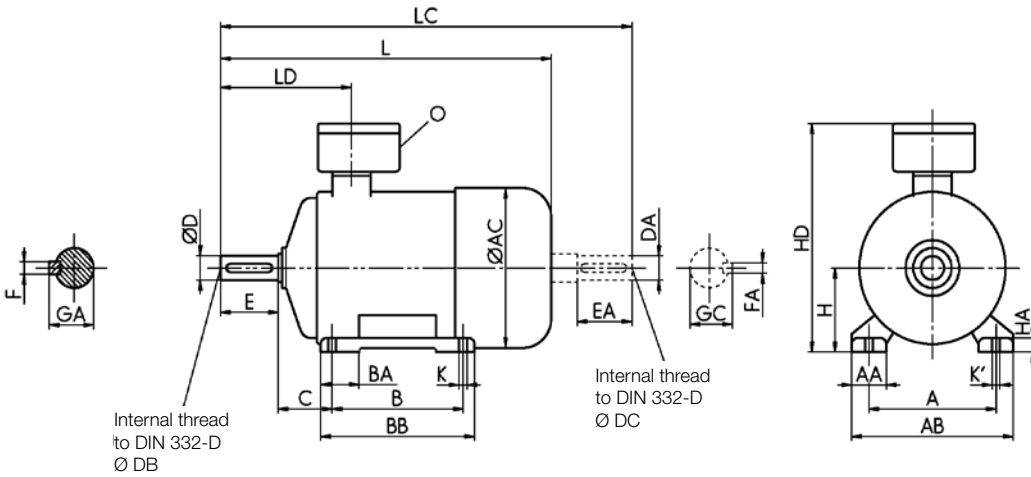

Type	A	AA	AB	AC	B	BA	BB	BC	C	H _{-0.5}	HA	HD	K _{H17}	K' _{H17}	L	Pole number			
																2	4	6	8
K82R...																			
63 M	100	20	120	134	80	25	100	10	40	63	6	227	Ø 7	-	239	239	239	239	
71 M	112	30	139	145	90	25	110	10	45	71	10	235	Ø 7	-	278	278	278	278	
80 M	125	35	160	163	100	35	130	15	50	80	12	260	Ø 10	-	313	313	313	313	
90 S	140	40	180	183	100	40	130	15	56	90	12	275	Ø 10	-	364	364	364	364	
90 L	140	40	180	183	125	40	155	15	56	90	12	275	Ø 10	-	364	364	364	364	
100 L	160	45	200	201	140	45	175	17.5	63	100	15	305	Ø 12	-	415	415	415	415	
112 M	190	50	235	225	140	50	175	17.5	70	112	17	317	Ø 12	-	425	425	425	425	
132 S	216	60	266	265	140	60	187	23.5	89	132	20	411	Ø 12	-	529	529	529	529	
132 M	216	60	266	265	178	60	225	23.5	89	132	20	411	Ø 12	-	-	529	529	529	
160 M	254	65	310	318	210	100	300	23	108	160	25	477	15	20	713	676	676	676	
160 L	254	65	310	318	254	100	300	23	108	160	25	477	15	20	713	676	676	676	
180 M	279	75	350	353	241	100	340	30	121	180	25	545	15	20	726	726	-	-	
180 L	279	75	350	353	279	100	340	30	121	180	25	545	15	20	-	726	726	726	
200 L	318	80	390	393	305	90	365	30	133	200	30	581	20	26	789	789	789	789	

Type	A	AA	AB	AC	B	BA	BB	BC	C	H _{-0.5}	HA	HD	K _{H17}	K' _{H17}	L	Pole number			
																2	4	6	8
K82R...																			
225 S	356	85	450	455	286	90	370	29.5	149	225 _{-0.5}	35	634	20	26	-	937	-	888	
225 M	356	85	450	455	311	90	370	29.5	149	225 _{-0.5}	35	634	20	26	907	937	888	888	
250 M	406	105	510	493	349	110	420	35.5	168	250 _{-0.5}	40	731	26	35	1000	1000	934	934	
280 S	457	110	570	548	368	120	500	40.5	190	280 ₋₁	45	802	26	35	1109	1109	1109	1109	
280 M	457	110	570	548	419	120	500	40.5	190	280 ₋₁	45	802	26	35	1109	1109	1109	1109	
315 S	508	150	630	635	406	210	615	53	216	315 ₋₁	40	897	39	30	1268	1298	1218	1218	
315 M	508	150	630	635	457	210	615	53	216	315 ₋₁	40	897	39	30	1268	1298	1218	1218	
315 L1	508	150	630	635	508	210	615	53	216	315 ₋₁	40	897	39	30	1268	1298	1218	1218	
315 L2	508	150	630	635	508	210	615	53	216	315 ₋₁	40	897	39	30	1468	1498	1418	1498	
315 L3	508	150	630	635	508	210	615	53	216	315 ₋₁	40	897	39	30	1468	1498	1418	1498	
355 M	610	180	720	725	560	220	720	45	254	355 ₋₁	50	1084	30	39	-	-	1597	1597	
355 L1	610	180	720	725	630	220	720	45	254	355 ₋₁	50	1084	30	39	1667	1697	1597	1597	
355 L2	610	180	720	725	630	220	720	45	254	355 ₋₁	50	1084	30	39	1667	1667	1597	1597	
355 L3	610	180	720	725	630	220	720	45	254	355 ₋₁	50	1084	30	39	1747	1777	-	-	
400 M	686	130	800	810	630	150	1264	152	280	400 ₋₁	34	1146	Ø 35	-	-	1907	1907	1907	
400 L	686	130	800	810	710	150	1264	152	280	400 ₋₁	34	1146	Ø 35	-	1837	1907	1907	1907	
450 M	760	150	900	910	710	180	1135	150	280	450 ₋₁	35	1264	Ø 35	-	-	1903	1903	1903	
450 L	760	150	900	910	840	180	1135	150	280	450 ₋₁	35	1264	Ø 35	-	-	1903	1903	1903	

Size 63 in T4 non-ventilated.
Lifting eye bolts from size 90
Dimension AC measured over screw head.
Dimension HD for Ex "e", rotatable.
Applies also for series BD ...

¹⁾ Type of construction IM V5 with protective canopy.
²⁾ For type 250 to 400-4, 6, 8: Specifications for 2 poles apply for dimensions DA, EA, GC, FA, DC.
For type 450-6, 8: Specifications for 4 poles apply for dimensions EA, GC, FA, DC.

Type K82R...	LC			LD	0	Shaft end			E, EA	GA, GC			F, FA	DB, DC	
	Pole number					D, DA									
	2	4	6, 8												
63 M	274	274	274	104	2 x M25 x 1.5	11 ₆		23	12.5			4		M4	
71 M	334	334	334	111	2 x M25 x 1.5	14 ₆		30	16			5		M5	
80 M	387	387	387	116	2 x M25 x 1.5	19 ₆		40	21.5			6		M6	
90 S	445	445	445	137	2 x M25 x 1.5	24 ₆		50	27			8		M8	
90 L	445	445	445	137	2 x M25 x 1.5	24 ₆		50	27			8		M8	
100 L	510	510	510	149	2 x M32 x 1.5	28 ₆		60	31			8		M10	
112 M	526	526	526	154	2 x M32 x 1.5	28 ₆		60	31			8		M10	
132 S	645	645	645	226	2 x M32 x 1.5	38 ₆		80	41			10		M12	
132 M	-	645	645	226	2 x M32 x 1.5	38 ₆		80	41			10		M12	
160 M	864	864	864	261	2 x M40 x 1.5	42 ₆		110	45			12		M16	
160 L	864	864	864	261	2 x M40 x 1.5	42 ₆		110	45			12		M16	
180 M	909	909	-	369	2 x M40 x 1.5	48 ₆		110	51.5			14		M16	
180 L	-	909	909	369	2 x M40 x 1.5	48 ₆		110	51.5			14		M16	
200 L	983	983	983	390	2 x M50 x 1.5	55 ₆		110	59			16		M20	

Type K82R...	LC			LD			Shaft end			E, EA ²⁾			GA, GC ²⁾			F, FA ²⁾			DB, DC	
	Pole number			Pole number			D _{m6} , DA _{m6}													
	2	4	6, 8	2	4, 6, 8	0	2	4	6, 8	2	4, 6, 8	2	4	6, 8	2	4, 6, 8	2	4, 6, 8	2	4, 6, 8
225 S	-	1175	1175	-	377	2 x M50 x 1.5	-	60	60	-	140	-	64	64	-	18	-	-	M20	M20
225 M	1145	1175	1175	347	377	2 x M50 x 1.5	55	60	60	110	140	59	64	64	16	18	18	18	M20	M20
250 M	1250	1250	1250	482	482	2 x M63 x 1.5	60	65	65	140	140	64	69	69	18	18	18	18	M20	M20
280 S	1375	1375	1375	483	483	2 x M63 x 1.5	65	75	75	140	140	69	79.5	79.5	18	20	20	20	M20	M20
280 M	1375	1375	1375	483	483	2 x M63 x 1.5	65	75	75	140	140	69	79.5	79.5	18	20	20	20	M20	M20
315 S	1543	1573	1573	496	526	2 x M63 x 1.5	65	80	80	140	170	69	85	85	18	22	22	22	M20	M20
315 M	1543	1573	1573	496	526	2 x M63 x 1.5	65	80	80	140	170	69	85	85	18	22	22	22	M20	M20
315 L1	1543	1573	1573	496	526	2 x M63 x 1.5	65	80	80	140	170	69	85	85	18	22	22	22	M20	M20
315 L2	1743	1773	1773	496	526	2 x M63 x 1.5	65	80	80	140	170	69	85	85	18	22	22	22	M20	M20
315 L3	1743	1773	1773	496	526	2 x M63 x 1.5	65	80	80	140	170	69	85	85	18	22	22	22	M20	M20
355 M	-	-	1980	-	702	2 x M80 x 2	75	90	90	140	170	79.5	95	95	20	25	25	25	M20	M24
355 L1	1925	1980	1980	672	702	2 x M80 x 2	75	90	90	140	170	79.5	95	95	20	25	25	25	M20	M24
355 L2	1950	1980	1980	672	702	2 x M80 x 2	75	90	90	140	170	79.5	95	95	20	25	25	25	M20	M24
355 L3	2030	2060	-	672	702	2 x M80 x 2	75	90	90	140	170	79.5	95	95	20	25	25	25	M20	M24
400 M	-	2190	2190	-	788	2 x M95 x 2	75	100	100	140	210	79.5	106	106	20	28	28	28	M20	M24
400 L	2120	2190	2190	718	788	2 x M95 x 2	75	100	100	140	210	79.5	106	106	20	28	28	28	M20	M24
450 M	-	2280	2280	-	826	2 x M95 x 2	75	100	110	140	210	79.5	106	116	20	28	28	28	M20	M24
450 L	-	2280	2280	-	826	2 x M95 x 2	75	100	110	140	210	79.5	106	116	20	28	28	28	M20	M24

**Three-phase motors with squirrel-cage rotor for operation in Zone 1 according to EN 60079-1
Type of explosion protection – Flameproof enclosure „d/de“ („db/db eb“), Standard Efficiency IE1**

with surface cooling with radial fan, type of cooling IC 411

Type of construction IM B5, IM V1¹⁾, IM V3

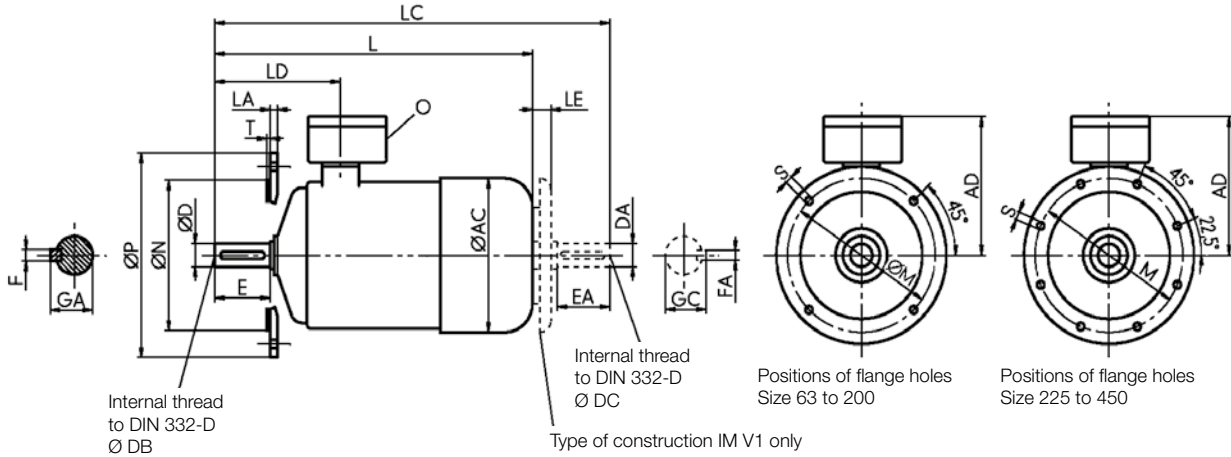

Type K82R...	Mounting flange							L				LC				
	LA	M	N	P	S _{H17}	T	AC	AD	Pole number				Pole number			
									2	4	6	8	2	4	6	8
63 M	9	115	95 ₆	140	10	3	134	164	239	239	239	239	274	274	274	274
71 M	9	130	110 ₆	160	10	3.5	145	164	278	278	278	278	334	334	334	334
80 M	12	165	130 ₆	200	12	3.5	163	180	313	313	313	313	387	387	387	387
90 S	12	165	130 ₆	200	12	3.5	183	185	364	364	364	364	445	445	445	445
90 L	12	165	130 ₆	200	12	3.5	183	185	364	364	364	364	445	445	445	445
100 L	16	215	180 ₆	250	14.5	4	201	205	415	415	415	415	510	510	510	510
112	16	215	180 ₆	250	14.5	4	225	205	425	425	425	425	526	526	526	526
132 S+M	16	265	230 ₆	300	14.5	4	265	279	529	529	529	529	645	645	645	645
160 M+L	20	300	250 ₆	350	18.5	5	318	317	713	676	676	676	864	864	864	864
180 M	20	300	250 ₆	350	18.5	5	353	365	726	726	-	-	909	909	-	-
180 L	20	300	250 ₆	350	18.5	5	353	365	-	726	726	726	-	909	909	909
200 L	20	350	300 ₆	400	18.5	5	393	381	789	789	789	789	983	983	983	983

Type K82R...	Mounting flange							L				LC				
	LA	M	N _{H6}	P	S _{H17}	T	AC	AD	Pole number				Pole number			
									2	4	6	8	2	4	6	8
225 S	22	400	350	450	18.5	5	455	409	-	937	-	888	-	1175	-	1175
225 M	22	400	350	450	18.5	5	455	409	907	937	888	888	1145	1175	1175	1175
250 M	18	500	450	550	18.5	5	493	471	1000	1000	934	934	1250	1250	1250	1250
280 S	18	500	450	550	18.5	5	548	511	1109	1109	1109	1109	1375	1375	1375	1375
280 M	18	500	450	550	18.5	5	548	511	1109	1109	1109	1109	1375	1375	1375	1375
315 S	22	600	550	660	24	6	635	581	1268	1298	1218	1218	1543	1573	1573	1573
315 M	22	600	550	660	24	6	635	581	1268	1298	1218	1218	1543	1573	1573	1573
315 L1	22	600	550	660	24	6	635	581	1268	1298	1218	1218	1543	1573	1573	1573
315 L2	22	600	550	660	24	6	635	581	1468	1498	1418	1498	1743	1773	1773	1773
315 L3	22	600	550	660	24	6	635	581	1468	1498	1418	1498	1743	1773	1773	1773
335 M	25	740	680	800	24	6	725	729	-	-	1597	1597	-	-	1980	1980
355 L1	25	740	680	800	24	6	725	729	1667	1697	1597	1597	1925	1980	1980	1980
355 L2	25	740	680	800	24	6	725	729	1667	1697	1597	1597	1950	1980	1980	1980
355 L3	25	740	680	800	24	6	725	729	1747	1777	-	-	2030	2060	-	-
400 M	28	940	880	1000	28	6	810	746	-	1907	1907	1907	-	2190	2190	2190
400 L	28	940	880	1000	28	6	810	746	1837	1907	1907	1907	2120	2190	2190	2190
450 M	28	940	880	1000	28	6	910	814	-	1903	1903	1903	-	2280	2280	2280
450 L	28	940	880	1000	28	6	910	814	-	1903	1903	1903	-	2280	2280	2280

Size 63 in T4 non-ventilated.
Mounting flange according to EN 50347, form FF.
Lifting eye bolts from size 90
Dimension AC measured over screw head.
Dimension HD refers to terminal space Ex "e".
Terminal space can be rotated by 4 x 90°.

Applies also for series BD ...
Size 400 to 450 only available in type of construction V1.

¹⁾ Type of construction IM V5 with protective canopy.
²⁾ For type 250 to 400-4, 6, 8: Specifications for 2 poles apply for dimensions DA, EA, GC, FA, DC.
For type 450-6, 8: Specifications for 4 poles apply for dimensions EA, GC, FA, DC.

Type K82R...	LD	LE Pole number			0	Shaft end D, DA			E, EA	GA, GC	F, FA	DB, DC
		2	4	6, 8		2	4	6, 8				
63 M	104	-	-	-	2 x M25 x 1.5	11j6		23	12.5	4	M4	
71 M	111	25	25	25	2 x M25 x 1.5	14j6		30	16	5	M5	
80 M	116	25	25	25	2 x M25 x 1.5	19j6		40	21.5	6	M6	
90 S	137	25	25	25	2 x M25 x 1.5	24j6		50	27	8	M8	
90 L	137	25	25	25	2 x M25 x 1.5	24j6		50	27	8	M8	
100 L	149	30	30	30	2 x M32 x 1.5	28j6		60	31	8	M10	
112 M	154	30	30	30	2 x M32 x 1.5	28j6		60	31	8	M10	
132 S+M	226	30	30	30	2 x M32 x 1.5	38k6		80	41	10	M12	
160 M+L	261	66	66	66	2 x M40 x 1.5	42k6		110	45	12	M16	
180 M	369	66	66	-	2 x M40 x 1.5	48k6		110	51.5	14	M16	
180 L	369	-	66	66	2 x M40 x 1.5	48k6		110	51.5	14	M16	
200 L	390	77	77	77	2 x M50 x 1.5	55m6		110	59	16	M20	

Type K82R...	LD			0	Shaft end D _{ms} , DA _{ms} ²⁾			E, EA ²⁾		GA, GC ²⁾		F, FA ²⁾		DB, DC ²⁾				
	2	4, 6, 8	Pole number 2 4 6, 8		2	4	6, 8	2	4, 6, 8	2	4	6, 8	2	4, 6, 8	2	4, 6, 8		
225 S	-	377	-	87	87	2 x M50 x 1.5	-	60	60	-	140	-	64	64	-	18	-	M20
225 M	347	377	87	87	87	2 x M50 x 1.5	55	60	60	110	140	59	64	64	16	18	M20	M20
250 M	482	482	94	94	94	2 x M63 x 1.5	60	65	65	140	140	64	69	69	18	18	M20	M20
280 S	483	483	110	110	110	2 x M63 x 1.5	65	75	75	140	140	69	79.5	79.5	18	20	M20	M20
280 M	483	483	110	110	110	2 x M63 x 1.5	65	75	75	140	140	69	79.5	79.5	18	20	M20	M20
315 S	496	526	115	115	115	2 x M63 x 1.5	65	80	80	140	170	69	85	85	18	22	M20	M20
315 M	496	526	115	115	115	2 x M63 x 1.5	65	80	80	140	170	69	85	85	18	22	M20	M20
315 L1	496	526	115	115	115	2 x M63 x 1.5	65	80	80	140	170	69	85	85	18	22	M20	M20
315 L2	496	526	115	115	115	2 x M63 x 1.5	65	80	80	140	170	69	85	85	18	22	M20	M20
315 L3	496	526	115	115	115	2 x M63 x 1.5	65	80	80	140	170	69	85	85	18	22	M20	M20
355 M	-	702	130	130	130	2 x M80 x 2	75	90	90	140	170	79.5	95	95	20	25	M20	M24
355 L1	672	702	130	130	130	2 x M80 x 2	75	90	90	140	170	79.5	95	95	20	25	M20	M24
355 L2	672	702	130	130	130	2 x M80 x 2	75	90	90	140	170	79.5	95	95	20	25	M20	M24
355 L3	672	702	130	130	130	2 x M80 x 2	75	90	90	140	170	79.5	95	95	20	25	M20	M24
400 M	-	788	130	130	130	2 x M95 x 2	75	100	100	140	210	79.5	106	106	20	28	M20	M24
400 L	718	788	130	130	130	2 x M95 x 2	75	100	100	140	210	79.5	106	106	20	28	M20	M24
450 M	704	826	130	130	130	2 x M95 x 2	75	100	110	140	210	79.5	106	116	20	28	M20	M24
450 L	704	826	130	130	130	2 x M95 x 2	75	100	110	140	210	79.5	106	116	20	28	M20	M24

For pole-switching motors (4/2, 6/4 and 8/4), the 4-pole shaft end is used.
 Exception: Motors in sizes 355, 400 and 450 with pole-switching configuration 4/2.
 In this case, the 2-pole shaft end is used.
 The length dimension L corresponds to 4-pole motors for all sizes.

**Three-phase motors with squirrel-cage rotor for operation in Zone 1 according to EN 60079-1
Type of explosion protection – Flameproof enclosure „d/de“ („db/db eb“), Standard Efficiency IE1**

with surface cooling with radial fan, type of cooling IC 411

Type of construction IM B14, IM B34; IM V17¹⁾, IM V18¹⁾, IM V19, IM V37

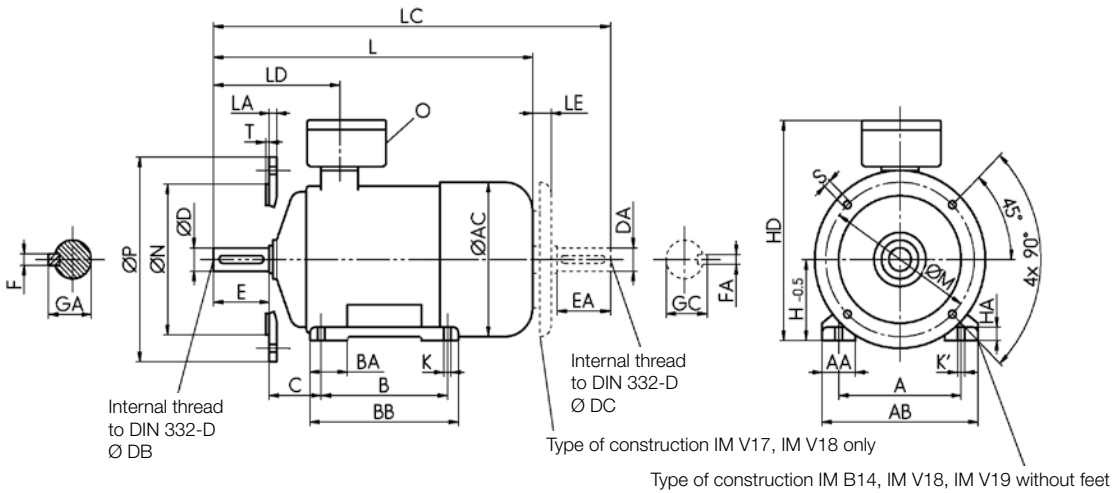

Type IE..K82R...	A	AA	AB	AC	B	BA	BB	BC	C	H _{-0.5}	HA	HD	K _{H17}
63 M	100	20	120	134	80	25	100	10	40	63	6	227	Ø 7
71 M	112	30	139	145	90	25	110	10	45	71	10	235	Ø 7
80 M	125	35	160	163	100	35	130	15	50	80	12	260	Ø 10
90 S	140	40	180	183	100	40	130	15	56	90	12	275	Ø 10
90 L	140	40	180	183	125	40	155	15	56	90	12	275	Ø 10
100 L	160	45	200	201	140	45	175	17.5	63	100	15	305	Ø 12
112 M	190	50	235	225	140	50	175	17.5	70	112	17	317	Ø 12
132 S	216	60	266	265	140	60	187	23.5	89	132	20	411	Ø 12
132 M	216	60	266	265	178	60	225	23.5	89	132	20	411	Ø 12

Type K82R...	L	LC	LE	LD	Shaft end						
					O	D, DA	E, EA	GA, GC	F, FA	DB, DC	
63 M	239	274	---	104	2 x M25 x 1.5	11 _{j6}	23	12.5	4	M4	
71 M	278	334	25	111	2 x M25 x 1.5	14 _{j6}	30	16	5	M5	
80 M	313	387	25	116	2 x M25 x 1.5	19 _{j6}	40	21.5	6	M6	
90 S+L	364	445	25	137	2 x M25 x 1.5	24 _{j6}	50	27	8	M8	
100 L	415	510	30	149	2 x M32 x 1.5	28 _{j6}	60	31	8	M10	
112 M	425	526	30	154	2 x M32 x 1.5	28 _{j6}	60	31	8	M10	
132 S+M	529	645	30	226	2 x M32 x 1.5	38 _{k6}	80	41	10	M12	

Type K82R...	Mounting flange					
	LA	M	N _{j6}	P	S	T
63 M	8	75	60	90	M5	2.5
71 M	8	85	70	105	M6	2.5
80 M	10	100	80	120	M6	3
90 S+L	10	115	95	140	M8	3
100 L	12	130	110	160	M8	3.5
112 M	12	130	110	160	M8	3.5
132 S+M	12	165	130	200	M10	3.5

Size 63 in T4 non-ventilated.
Mounting flange according to EN 50347, form FT.
Lifting eye bolts from size 90
Dimension AC measured over screw head.
Dimension HD refers to terminal space Ex "e".
Terminal space can be rotated by 4 x 90°.
Applies also for series BD ...

¹⁾ Protective canopy required for type of construction IM V17 and IM V18
²⁾ For pole-switching motors (4/2, 6/4 and 8/4), the 4-pole shaft end is used.
Exception: Motors in sizes 355, 400 and 450 with pole-switching configuration 4/2.
In this case, the 2-pole shaft end is used. The length dimension L corresponds to 4-pole motors for all sizes.

Overview of technical data

The most important technical data are summarised in the following table.
Further information can be taken from the catalogue section "Introduction" (Chapter 1).

Product group	Squirrel-cage rotor, IEC/DIN
Explosion protection type	Explosion protection type "n" (Increased safety "ec") / Protection by enclosure "tb", "tc"
Rated output	Ex nA (Ex ec)/(IE.) – KPR/KPER/K..R/W..R, 0.06 to 650 kW Zone 21/22/(IE.) – KPR/KPER/K..R/W..R, 0.06 to 650 kW
Sizes	Ex nA(Ex ec)/(IE.) – KPR/KPER/K..R/W..R, 56 to 400 Zone 21/22/(IE.) – KPR/KPER/K..R/W..R, 56 to 400
Housing material	Grey cast iron
Rated torque	0.4 Nm to 5770 Nm
Efficiency classification/ efficiency determination	IEC/EN 60034-30-1 / IEC/EN 60034-2-1, ≤ 1 kW direct measurement, > 1 kW residual loss method
Method of connection	Single-speed motors are designed in star-delta configuration as standard.
Stator winding insulation	Thermal class 155, optional 155 [F(B)], 180 to IEC/EN 60034-1
Degree of protection	IP 55, optimally IP 56 or higher to IEC/EN 60034-5
Type of cooling	IC 411, IC 416, IC 71W (IC 31W) to IEC/EN 60034-6
Coolant temperature/ installation altitude	Standard -20 °C to +40 °C, max. +55 °C Deviating coolant temperatures upon request Altitude 1000 m above sea level
Rated voltage	Standard voltages to EN 60038 50 Hz: 230 V, 400 V, 500 V, 690 V, 60 Hz: 275 V, 460 V, 480 V, 600 V
Duty types	Continuous duty S1, converter-fed operation S9
Types of construction	IM B3, IM B35, IM B5 and derived types to IEC/EN 60034-7
Paint finish	Normal finish "Moderate", colour RAL 7031, blue-grey Special finish "Worldwide", colour RAL 7031, blue-grey
Vibration severity grade	Grade "A" as standard for machines with no special vibration requirements
Shaft ends	to DIN 748 (IEC 60072), balanced with half-key
Limit speeds	Please refer to the section of "Limit speeds" in catalogue section "Motors for converter-fed operation", Chapter 4.
Bearing design	Please refer to the tables of bearing design data in catalogue section "Standard motors", Chapter 2.
Motor mass	Please refer to the technical selection lists.
Terminal boxes	Please refer to the section "Terminal boxes".
Documentation	An operating and maintenance manual, a terminal plan and a safety data sheet are supplied with each motor.
Tolerances	Please refer to the section "Tolerances" in catalogue section "Introduction", Chapter 1.
Options	Please refer to the section "Overview of modifications" in catalogue section "Introduction", Chapter 1.

Motor selection data

Three-phase motors with squirrel-cage rotor, Premium Efficiency IE3
 Type of explosion protection „n“ (Increased safety „ec“)
 for operation in Zone 2 according to EN 60079-15 (EN 60079-7)

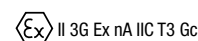

for rated voltage, temperature classes T1, T2 and T3
 with surface cooling, duty type S1, continuous duty
 thermal class F, degree of protection IP 55, 50 Hz

Motor selection data														Design point 400 V, 50 Hz	
Type	P	M _B	n _B	η _B			cosφ _B	I _B	I _A /I _B	M _A /M _B	M _S /M _B	M _R /M _B	Certificate no.	J	m
	kW	Nm	rpm	(IEC/EN 60034-30-1)			-	A	-	-	-	-	IBExU...	kgm ²	kg
				100 %	75 %	50 %									
Synchronous speed 3000 rpm – 2-pole version															
IE3-KPER 90 S2 Ex II 3G Ex nA II T3	1.5	4.94	2900	IE3- 84.2	85.4	83.2	0.81	3.12	7.9	3.5	3.5	4.4	IBExU06ATEXB002	0.0017	19
IE3-KPR 90 S2 Ex II 3G Ex nA II T3	1.5	4.92	2910	IE3- 84.2	86.6	84.5	0.86	2.9	9.1	3.0	2.7	3.7	IBExU06ATEXB001	0.00275	23.5
IE3-KPR 90 LY2 Ex II 3G Ex nA II T3	2.2	7.3	2880	IE3- 85.9	85.7	83.9	0.88	4.25	8.0	2.5	2.3	2.9	IBExU06ATEXB001	0.00275	23.5
IE3-KPR 90 L2 Ex II 3G Ex nA II T3	2.2	7.23	2905	IE3- 85.9	87.7	86.0	0.89	4.05	8.6	2.7	2.3	3.7	IBExU06ATEXB001	0.00333	29
IE3-KPR 100 LY2 Ex II 3G Ex nA II T3	3	9.81	2920	IE3- 87.1	88.0	86.3	0.82	6	7.7	2.3	2.2	3.5	IBExU06ATEXB001	0.0045	31
IE3-KPR 100 L2 Ex II 3G Ex nA II T3	3	9.78	2930	IE3- 87.1	88.2	87.5	0.85	5.8	9.1	2.3	2.0	3.6	IBExU06ATEXB001	0.0055	38
IE3-KPER 112 MY2 Ex II 3G Ex nA II T3	4	13.1	2920	IE3- 88.1	87.5	86.9	0.84	7.9	8.3	2.3	2.1	3.3	IBExU06ATEXB002	0.0055	38
IE3-KPER 112 MV2 Ex II 3G Ex nA II T3	4	13	2930	IE3- 88.1	89.3	88.1	0.85	7.6	9.0	2.7	2.4	3.7	IBExU06ATEXB002	0.0068	46
IE3-KPER 112 MX2 Ex II 3G Ex nA II T3	5.5	17.96	2925	IE3- 89.2	89.4	87.7	0.8	11.1	8.3	2.6	2.5	3.8	IBExU06ATEXB002	0.0068	46
IE3-KPER 132 S2T Ex II 3G Ex nA II T3	5.5	18	2925	IE3- 89.2	89.4	87.7	0.8	11.1	8.3	2.6	2.5	3.8	IBExU06ATEXB002	0.0068	48
IE3-W41R 112 M2 Ex nA IIC T3	4	13.0	2930	IE3- 89.2	89.2	87.9	0.87	7.4	6.9	1.5	1.2	2.9	IBExU03ATEXB004	0.011	60
IE3-W41R 132 S2 Ex nA IIC T3	5.5	18.0	2930	IE3- 89.2	88.6	87.0	0.84	10.5	7.7	1.9	1.3	3.5	IBExU03ATEXB004	0.011	65
IE3-W41R 132 SX2 Ex nA IIC T3	7.5	24.0	2925	IE3- 90.1	89.4	87.9	0.87	14.0	8.0	2.5	2.1	3.3	IBExU03ATEXB004	0.0168	75
IE3-W41R 160 M2 Ex nA IIC T3	11	36.0	2950	IE3- 91.4	91.7	90.5	0.90	19.5	8.0	2.2	1.8	3.2	IBExU03ATEXB004	0.0575	125
IE3-W41R 160 MX2 Ex nA IIC T3	15	49.0	2950	IE3- 91.9	92.0	91.3	0.91	26.0	7.9	2.2	1.7	3.1	IBExU03ATEXB004	0.0675	145
IE3-W41R 160 L2 Ex nA IIC T3	18.5	60.0	2960	IE3- 92.4	92.5	91.4	0.90	32.0	9.2	2.6	2.1	3.6	IBExU03ATEXB004	0.078	160
IE3-W41R 180 M2C Ex nA IIC T3	22	71	2975	IE3- 92.7	92.6	91.5	0.91	37.5	8.9	1.9	1.4	3.3	IBExU03ATEXB004	0.1717	214
IE3-W41R 200 L2 Ex nA IIC T3	30	97	2965	IE3- 93.3	92.2	90.6	0.88	52.5	8.6	2.1	1.6	3.3	IBExU03ATEXB004	0.36	305
IE3-W41R 200 LX2C Ex nA IIC T3	37	119	2980	IE3- 93.7	92.9	91.7	0.89	64.0	8.7	1.7	1.3	3.2	IBExU03ATEXB004	0.4757	310
IE3-W41R 225 M2 Ex nA IIC T3	45	145	2960	IE3- 94.0	93.7	93.0	0.89	77.5	8.8	2.3	1.9	3.2	IBExU03ATEXB004	0.375	375
IE3-W41R 250 M2 Ex nA IIC T3	55	177	2970	IE3- 94.6	94.4	93.6	0.91	92	8.9	2.2	1.9	3.2	IBExU03ATEXB004	0.65	510
IE3-W41R 280 S2 Ex nA IIC T3	75	241	2967	IE3- 94.7	94.5	93.9	0.89	128	8.1	1.9	1.9	2.8	IBExU03ATEXB004	0.65	500
IE3-W41R 280 M2 Ex nA IIC T3	90	289	2970	IE3- 95.0	94.5	94.0	0.90	152	8.4	2.2		3.1	IBExU03ATEXB004	0.675	545
IE3-W41R 315 S2 Ex nA IIC T3	110	354	2970	IE3- 95.2	94.5	93.5	0.89	187	10.0	1.9	1.7	3.0	IBExU03ATEXB004	1.21	750
IE3-W41R 315 M2 Ex nA IIC T3	132	423	2980	IE3- 95.4	95.0	94.5	0.89	224	10.0	2.0	1.8	3.0	IBExU03ATEXB004	1.44	815
IE3-W41R 315 MX2 Ex nA IIC T3	160	513	2980	IE3- 95.7	95.7	95.0	0.9	268	8.5	2.3	1.7	2.6	IBExU03ATEXB004	2.37	1095
IE3-W41R 315 MY2 Ex nA IIC T3	200	641	2980	IE3- 95.8	95.9	95.5	0.91	331	8.3	2.6	1.6	2.4	IBExU03ATEXB004	2.82	1200
IE3-W41R 315 L2 Ex nA IIC T3	250	800	2985	IE3- 96.0	96.0	95.9	0.92	409	8.4	2.5	1.4	2.3	IBExU03ATEXB004	3.66	1460
IE3-W41R 315 LX2 Ex nA IIC T3	315	1008	2985	IE3- 95.8	95.8	95.8	0.92	516	8.5	2.8	1.6	2.5	IBExU03ATEXB004	4.43	1700
IE3-W41R 355 M2G Ex nA IIC T3	355	1136	2985	IE3- 96.0	96.0	96.0	0.92	580	7.7	1.9	1.5	3.8	IBExU03ATEXB004	4.20	2000
IE3-W42R 355 MX2G Ex nA IIC T3	400	1278	2990	IE3- 95.8	95.8	95.3	0.91	665	8.5	1.5	1.2	2.5	IBExU03ATEXB004	5.50	2200
IE3-W42R 355 L2G Ex nA IIC T3	500	1597	2990	IE3- 95.8	95.8	95.3	0.90	840	9.0	2.0	1.3	3.0		7.10	2445
IE3-W42R 400 M2G Ex nA IIC T3	530	1690	2990	IE3- 95.8	95.4	95.0	0.84	950	8.5	1.7	1.1	2.2		8.44	3060
IE3-W42R 400 MX2G Ex nA IIC T3	570	1820	2990	IE3- 95.8	95.8	95.3	0.90	955	8.1	2.0	1.4	2.2		9.41	3200
IE3-W42R 400 L2G Ex nA IIC T3	650	2075	2990	IE3- 96.1	96.0	95.4	0.90	1085	8.1	2.2	1.2	2.4		10.41	3400

Optionally in dust-protected version, protection type: Protection by enclosure "tc" to EN 60079-31, double marking on rating plate.
 Other voltages and frequencies upon request. Changes are possible for motors which are not yet certified.

Three-phase motors with squirrel-cage rotor, Premium Efficiency IE3
Type of explosion protection „n“ (Increased safety „ec“)
for operation in Zone 2 according to EN 60079-15 (EN 60079-7)

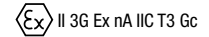

for rated voltage, temperature classes T1, T2 and T3
 with surface cooling, duty type S1, continuous duty
 thermal class F, degree of protection IP 55, 50 Hz

Motor selection data														Design point 400 V, 50 Hz	
Type	P	M _B	n _B	η _B			cosφ _B	I _B	I _A /I _B	M _A /M _B	M _S /M _B	M _R /M _B	Certificate no. IBExU...	J	m
	kW	Nm	rpm	100 %	75 %	50 %	-	A	-	-	-	-	IBExU...	kgm ²	kg
Synchronous speed 1500 rpm – 4-pole version															
IE3-KPER 63 K4 Ex II 3G Ex nA II T3	0.12	0.84	1365	IE3- 64.8	64.5	59.7	0.72	0.37	3.2	1.9	1.8	2.2	IBExU06ATEXB002	0.00024	5.2
IE3-KPR 63 G4 Ex II 3G Ex nA II T3	0.18	1.21	1415	IE3- 69.9	67.2	61.2	0.67	0.55	4.4	1.8	1.8	2.7	IBExU06ATEXB001	0.0005	7.1
IE3-KPER 71 K4 Ex II 3G Ex nA II T3	0.25	1.71	1395	IE3- 73.5	71.2	66.7	0.7	0.72	3.9	2.1	2.1	2.5	IBExU06ATEXB002	0.0005	7.8
IE3-KPR 71 K4 Ex II 3G Ex nA II T3	0.25	1.67	1430	IE3- 73.5	73.1	69.6	0.71	0.66	5.6	2.5	2.3	2.9	IBExU06ATEXB001	0.00087	9.9
IE3-KPR 71 GY4 Ex II 3G Ex nA II T3	0.37	2.48	1425	IE3- 77.3	76.8	73.0	0.69	1	4.9	2.4	2.4	3.0	IBExU06ATEXB001	0.00087	9.9
IE3-KPR 71 G4 Ex II 3G Ex nA II T3	0.37	2.47	1430	IE3- 77.3	78.2	73.1	0.69	0.98	6.2	2.8	2.6	3.2	IBExU06ATEXB001	0.00107	11
IE3-KPR 80 K4 Ex II 3G Ex nA II T3	0.55	3.67	1430	IE3- 80.8	81.0	80.1	0.8	1.25	6.0	2.4	2.3	2.7	IBExU06ATEXB001	0.00207	14.5
IE3-KPR 80 G4 Ex II 3G Ex nA II T3	0.75	4.96	1445	IE3- 82.5	82.3	79.6	0.77	1.7	7.0	3.1	3.1	3.7	IBExU06ATEXB001	0.0026	17
IE3-KPR 80 GX4 Ex II 3G Ex nA II T3	0.75	5.01	1430	IE3- 82.5	82.9	81.1	0.8	1.65	7.0	2.9	2.8	3.2	IBExU06ATEXB001	17.94	4600
IE3-KPR 90 SY4 Ex II 3G Ex nA II T3	1.1	7.3	1440	IE3- 84.1	82.6	79.7	0.76	2.5	6.7	2.8	2.7	3.7	IBExU06ATEXB001	0.004	22.5
IE3-KPR 90 S4 Ex II 3G Ex nA II T3	1.1	7.24	1450	IE3- 84.1	83.5	80.0	0.74	2.55	8.0	3.6	3.5	4.2	IBExU06ATEXB001	0.0045	28
IE3-KPR 90 L4 Ex II 3G Ex nA II T3	1.5	9.91	1445	IE3- 85.3	83.2	80.7	0.77	3.35	7.2	3.2	3.0	3.5	IBExU06ATEXB001	0.0045	28
IE3-KPR 90 LX4 Ex II 3G Ex nA II T3	1.5	9.85	1455	IE3- 85.3	84.0	80.6	0.75	3.4	9.5	4.5	3.8	4.9	IBExU06ATEXB001	0.0058	31
IE3-KPR 100 LY4 Ex II 3G Ex nA II T3	2.2	14.4	1455	IE3- 86.7	85.2	81.7	0.77	4.8	9.3	3.2	3.0	3.6	IBExU06ATEXB001	0.009	36
IE3-KPR 100 L4 Ex II 3G Ex nA II T3	2.2	14.49	1450	IE3- 86.7	87.0	85.1	0.81	4.55	8.2	2.9	2.7	3.8	IBExU06ATEXB001	0.011	45
IE3-KPR 100 LW4 Ex II 3G Ex nA II T3	2.2	14.4	1460	IE3- 86.7	86.4	84.3	0.76	4.75	8.6	3.8	3.7	4.5	IBExU06ATEXB001	0.013	50
IE3-KPR 100 LX4 Ex II 3G Ex nA II T3	3	19.7	1455	IE3- 87.7	86.3	84.5	0.77	6.5	9.0	3.3	3.1	3.9	IBExU06ATEXB001	0.011	45
IE3-KPR 100 LZ4 Ex II 3G Ex nA II T3	3	19.7	1455	IE3- 87.7	87.6	86.1	0.77	6.4	8.6	3.2	3.1	4.1	IBExU06ATEXB001	0.013	50
IE3-W41R 112 M4 Ex nA IIC T3	4	26	1470	IE3- 89.9	89.8	88.4	0.83	7.7	9.5	2.8	2.4	4.5	IBExU03ATEXB004	0.02	65
IE3-W41R 132 S4 Ex nA IIC T3	5.5	35	1480	IE3- 91.0	90.2	87.8	0.73	12.0	9.9	3.4	2.8	5.4	IBExU03ATEXB004	0.035	90
IE3-W41R 132 M4 Ex nA IIC T3	7.5	49	1475	IE3- 91.3	91.3	90.1	0.83	14.5	8.6	2.4	2.0	3.9	IBExU03ATEXB004	0.043	100
IE3-W41R 160 M4 Ex nA IIC T3	11	71	1475	IE3- 91.4	91.5	90.5	0.83	21.0	7.5	2.5	2.0	3.2	IBExU03ATEXB004	0.078	125
IE3-W41R 160 L4C Ex nA IIC T3	15	96	1490	IE3- 92.8	92.5	91.0	0.83	28.0	10.5	2.8	2.4	3.9	IBExU03ATEXB004	0.1567	175
IE3-W41R 180 M4 Ex nA IIC T3	18.5	120	1475	IE3- 92.7	92.9	92.0	0.84	34.5	6.9	1.9	1.7	3.0	IBExU03ATEXB004	0.168	210
IE3-W41R 180 L4 Ex nA IIC T3	22	142	1480	IE3- 93.0	93.0	92.1	0.84	40.5	7.6	2.2	2.0	3.2	IBExU03ATEXB004	0.203	240
IE3-W41R 200 L4C Ex nA IIC T3	30	193	1485	IE3- 93.6	92.4	92.4	0.85	54.5	7.0	1.6	1.4	2.6	IBExU03ATEXB004	0.411	327
IE3-W41R 225 S4C Ex nA IIC T3	37	237	1490	IE3- 93.9	93.8	93.2	0.85	67.0	7.4	1.9	1.4	2.7	IBExU03ATEXB004	0.4675	367
IE3-W41R 225 M4 Ex nA IIC T3	45	290	1482	IE3- 94.2	94.3	94.0	0.82	84	8.1	2.6	2.1	2.6	IBExU03ATEXB004	0.619	450
IE3-W41R 250 M4 Ex nA IIC T3	55	354	1485	IE3- 94.7	94.8	94.4	0.83	101	8.1	2.1	1.8	2.5	IBExU03ATEXB004	0.95	550
IE3-W41R 280 S4 Ex nA IIC T3	75	482	1485	IE3- 95.0	94.6	94.2	0.83	137	8.2	2.1	1.8	2.5	IBExU03ATEXB004	1.1	617
IE3-W41R 280 M4 Ex nA IIC T3	90	578	1487	IE3- 95.2	94.7	94.0	0.83	164	9.2	2.1	1.9	2.7	IBExU03ATEXB004	1.96	785
IE3-W41R 315 S4 Ex nA IIC T3	110	706	1487	IE3- 95.4	95.0	94.3	0.82	203	9.5	1.9	1.7	2.7	IBExU03ATEXB004	1.96	760
IE3-W41R 315 M4 Ex nA IIC T3	132	849	1485	IE3- 95.6	95.4	95.0	0.83	240	9.0	2.2	1.9	2.7	IBExU03ATEXB004	2.27	850
IE3-W41R 315 MX4 Ex nA IIC T3	160	1026	1490	IE3- 95.8	95.8	95.0	0.84	287	9.5	2.1	2.0	3.2	IBExU03ATEXB004	4.01	1120
IE3-W41R 315 MY4 Ex nA IIC T3	200	1282	1490	IE3- 96.0	95.8	95.5	0.87	346	9.5	2.1	1.7	2.7	IBExU03ATEXB004	4.82	1250
IE3-W41R 315 L4 Ex nA IIC T3	250	1602	1490	IE3- 96.2	96.2	96.0	0.87	431	9.4	2.2	1.8	2.7	IBExU03ATEXB004	5.93	1450
IE3-W41R 315 LX4 Ex nA IIC T3	315	2019	1490	IE3- 96.0	96.0	96.0	0.87	544	9.5	2.3	1.7	2.9	IBExU03ATEXB004	6.82	1630
IE3-W41R 355 M4 Ex nA IIC T3	355	2271	1493	IE3- 96.2	96.2	95.5	0.87	612	8.1	1.3	1.0	2.7	IBExU03ATEXB004	7.90	2150
IE3-W42R 355 MX4 Ex nA IIC T3	400	2557	1494	IE3- 96.0	96.0	95.5	0.84	719	8.0	1.7	1.4	2.4		9.50	2400
IE3-W42R 355 L4 Ex nA IIC T3	500	3205	1490	IE3- 96.0	96.0	95.5	0.84	899	7.2	1.6	1.2	2.2		10.00	2500
IE3-W42R 400 M4 Ex nA IIC T3	560	3582	1493	IE3- 96.0	96.0	95.5	0.84	1006	9.0	3.4	2.9	3.9		12.60	2900
IE3-W42R 400 MX4 Ex nA IIC T3	630	4030	1493	IE3- 96.0	96.0	95.5	0.85	1119	9.0	3.6	3.0	4.2		14.33	3100
IE3-W42R 400 L4 Ex nA IIC T3	710	4542	1493	IE3- 96.0	96.0	95.5	0.85	1261	9.0	3.9	3.1	4.2		16.29	3450

Optionally in dust-protected version, protection type: Protection by enclosure "tc" to EN 60079-31, double marking on rating plate.
 Other voltages and frequencies upon request. Changes are possible for motors which are not yet certified.

Three-phase motors with squirrel-cage rotor, Premium Efficiency IE3
Type of explosion protection „n“ (Increased safety „ec“)
for operation in Zone 2 according to EN 60079-15 (EN 60079-7)

II 3G Ex nA IIC T3 Gc

for rated voltage, temperature classes T1, T2 and T3
 with surface cooling, duty type S1, continuous duty
 thermal class F, degree of protection IP 55, 50 Hz

Motor selection data													Design point 400 V, 50 Hz		
Type	P	M _B	n _B	η _B			cosφ _B	I _B	I _A /I _B	M _A /M _B	M _S /M _B	M _R /M _B	Certificate no. IBExU...	J	m
	kW	Nm	rpm	100 %	75 %	50 %	-	A	-	-	-	-	IBExU...	kgm ²	kg
Synchronous speed 1000 rpm – 6-pole version															
IE3-KPR 63 G6 Ex II 3G Ex nA II T3	0.12	1.23	930	IE3- 57.7	60.0	54.0	0.56	0.5	2.8	1.9	1.8	2.1	IBExU06ATEXB001	0.00045	6.7
IE3-KPER 71 KY6 Ex II 3G Ex nA II T3	0.18	1.89	910	IE3- 63.9	62.0	56.5	0.55	0.75	2.9	1.7	1.7	2.1	IBExU06ATEXB002	0.0006	8.3
IE3-KPR 71 K6 Ex II 3G Ex nA II T3	0.18	1.85	930	IE3- 63.9	62.9	57.5	0.68	0.57	3.4	2.0	2.0	2.2	IBExU06ATEXB001	0.0013	11
IE3-KPR 71 GY6 Ex II 3G Ex nA II T3	0.25	2.54	940	IE3- 68.6	65.3	58.5	0.63	0.84	4.0	2.2	2.2	2.9	IBExU06ATEXB001	0.0013	10
IE3-KPR 71 G6 Ex II 3G Ex nA II T3	0.25	2.55	935	IE3- 68.6	66.9	62.2	0.67	0.75	3.9	2.3	2.3	2.5	IBExU06ATEXB001	0.00175	12.5
IE3-KPR 80 K6 Ex II 3G Ex nA II T3	0.37	3.72	950	IE3- 73.5	72.9	69.2	0.7	1.03	4.0	1.9	1.9	2.4	IBExU06ATEXB001	0.00325	15
IE3-KPR 80 G6 Ex II 3G Ex nA II T3	0.55	5.53	950	IE3- 77.2	75.9	72.4	0.69	1.5	4.1	2.1	2.1	2.5	IBExU06ATEXB001	0.00425	18
IE3-KPR 90 SY6 Ex II 3G Ex nA II T3	0.75	7.5	955	IE3- 78.9	78.3	75.1	0.71	1.95	4.9	2.4	2.3	2.6	IBExU06ATEXB001	0.00625	24
IE3-KPR 90 S6 Ex II 3G Ex nA II T3	0.75	7.54	950	IE3- 78.9	79.7	77.5	0.73	1.87	5.3	2.4	2.2	2.9	IBExU06ATEXB001	0.0072	30
IE3-KPR 90 L6 Ex II 3G Ex nA II T3	1.1	11	955	IE3- 81.0	81.0	78.5	0.71	2.75	5.4	2.5	2.4	2.8	IBExU06ATEXB001	0.0072	30
IE3-KPR 100 LX6 Ex II 3G Ex nA II T3	1.5	15	955	IE3- 82.5	83.5	81.5	0.76	3.45	5.9	2.3	2.2	2.8	IBExU06ATEXB001	0.0139	36
IE3-KPER 112 MV6 Ex II 3G Ex nA II T3	2.2	22	955	IE3- 84.3	83.6	80.9	0.74	5.15	5.7	2.4	2.3	2.9	IBExU06ATEXB002	0.0155	48
IE3-KPER 112 MZ6 Ex II 3G Ex nA II T3	2.2	21.88	960	IE3- 84.3	84.0	81.5	0.75	5	6.9	3.0	3.0	3.8	IBExU06ATEXB002	0.018	50
IE3-W41R 132 S6 Ex nA IIC T3	3	30.0	965	IE3- 86.3	86.7	85.6	0.82	6.1	6.2	2.0	1.3	3.1	IBExU03ATEXB004	0.029	70
IE3-W41R 132 M6 Ex nA IIC T3	4	40.0	965	IE3- 86.8	87.0	86.0	0.80	8.3	4.8	1.7	1.4	2.4	IBExU03ATEXB004	0.043	75
IE3-W41R 132 MX6 Ex nA IIC T3	5.5	54.0	970	IE3- 88.6	88.6	87.2	0.80	11.0	6.0	2.1	1.7	3.0	IBExU03ATEXB004	0.053	105
IE3-W41R 160 M6 Ex nA IIC T3	7.5	73.0	980	IE3- 90.2	90.0	88.3	0.83	14.5	6.4	2.4	2.0	3.0	IBExU03ATEXB004	0.145	145
IE3-W41R 160 L6C Ex nA IIC T3	11	107.0	985	IE3- 91.4	91.2	89.8	0.85	20.5	6.8	2.2	2	2.8	IBExU03ATEXB004	0.166	168
IE3-W41R 180 L6C Ex nA IIC T3	15	145.0	985	IE3- 91.2	91.3	90.2	0.87	27.5	6.8	2	1.7	2.7	IBExU03ATEXB004	0.3396	214
IE3-W41R 200 L6 Ex nA IIC T3	18.5	180.0	980	IE3- 91.8	91.7	90.5	0.87	33.5	7.2	2.3	2	3	IBExU03ATEXB004	0.514	310
IE3-W41R 200 LX6C Ex nA IIC T3	22	213.0	985	IE3- 92.2	91.5	90.0	0.87	39.5	7.6	2.1	1.7	2.9	IBExU03ATEXB004	0.6476	321
IE3-W41R 225 M6 Ex nA IIC T3	30	291	984	IE3- 92.9	92.2	91.0	0.84	55.5	7.2	2.7	2.2	2.9	IBExU03ATEXB004	0.92	400
IE3-W41R 250 M6 Ex nA IIC T3	37	359	985	IE3- 93.3	93.2	92.3	0.86	66.5	7.1	2.8	2.0	2.7	IBExU03ATEXB004	1.48	545
IE3-W41R 280 S6 Ex nA IIC T3	45	434	990	IE3- 93.7	93.5	91.5	0.86	80.5	8.5	2.1	1.8	2.8	IBExU03ATEXB004	2.63	695
IE3-W41R 280 M6 Ex nA IIC T3	55	531	990	IE3- 94.2	94.1	93.1	0.85	99	9.0	2.2	1.9	3.1	IBExU03ATEXB004	3.33	815
IE3-W41R 315 S6 Ex nA IIC T3	75	723	990	IE3- 94.6	94.0	93.5	0.86	133	8.2	1.8	1.4	2.3	IBExU03ATEXB004	5.55	1060
IE3-W41R 315 M6 Ex nA IIC T3	90	868	990	IE3- 94.9	94.0	93.0	0.83	165	8.5	2.2	1.7	2.8	IBExU03ATEXB004	6	1100
IE3-W41R 315 MX6 Ex nA IIC T3	110	1.061	990	IE3- 95.1	95.0	94.5	0.86	194	8.5	2.5	1.7	2.7	IBExU03ATEXB004	6.67	1210
IE3-W41R 315 L6 Ex nA IIC T3	132	1.267	995	IE3- 95.4	95.0	94.5	0.87	230	9.0	2.8	2.0	3.2	IBExU03ATEXB004	8.6	1550
IE3-W41R 355 M6 Ex nA IIC T3	160	1.536	995	IE3- 95.6	95.0	94.6	0.82	295	8.0	2.1	0.0	2.7	IBExU03ATEXB004	8.2	1850
IE3-W42R 355 MX6 Ex nA IIC	200	1919	995	IE3- 95.8	95.2	95.0	0.83	363	8.0	1.8	1.3	2.5		12.10	2200
IE3-W42R 355 L6 Ex nA IIC	250	2402	994	IE3- 95.8	95.5	95.0	0.81	468	7.0	1.8	1.3	2.3		14.00	2400
IE3-W42R 355 LX6 Ex nA IIC	315	3032	992	IE3- 95.8	95.5	95.3	0.86	554	7.4	2.5	2.0	2.7		14.00	2400
IE3-W42R 400 MY6 Ex nA IIC	355	3407	995	IE3- 95.8	95.5	94.5	0.85	632	8.0	2.0	1.6	2.6		16.54	2900
IE3-W42R 400 M6 Ex nA IIC	400	3847	993	IE3- 95.8	95.5	94.5	0.87	696	7.0	1.8	1.5	2.3		16.54	2900
IE3-W42R 400 MX6 Ex nA IIC	450	4327	993	IE3- 95.8	95.7	94.6	0.83	821	7.3	1.8	1.5	2.1		18.44	3100
IE3-W42R 400 L6 Ex nA IIC	500	4808	993	IE3- 95.8	95.6	94.5	0.83	911	7.5	1.9	1.7	2.2		20.63	3200

Optionally in dust-protected version, protection type: Protection by enclosure "tc" to EN 60079-31, double marking on rating plate.
 Other voltages and frequencies upon request. Changes are possible for motors which are not yet certified.

Three-phase motors with squirrel-cage rotor, Premium Efficiency IE3
Type of explosion protection „n“ (Increased safety „ec“)
for operation in Zone 2 according to EN 60079-15 (EN 60079-7)

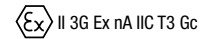

for rated voltage, temperature classes T1, T2 and T3
 with surface cooling, duty type S1, continuous duty
 thermal class F, degree of protection IP 55, 50 Hz

Motor selection data													Design point 400 V, 50 Hz		
Type	P kW	M _B Nm	n _B rpm	η _B (IEC/EN 60034-30-1)			cosφ _B -	I _B 400 V A	I _A /I _B -	M _A /M _B -	M _S /M _B -	M _K /M _B -	Certificate no. IBExU...	J	m
				100 %	75 %	50 %								kgm ²	kg
Synchronous speed 750 rpm – 8-pole version															
IE3-KPR 71 G8 Ex II 3G Ex nA II T3	0.12	1.67	685	IE3- 50.7	48.8	43.0	0.64	0.48	2.6	1.7	1.7	2.0	IBExU06ATEXB001	0.0013	9.9
IE3-KPER 80 K8 Ex II 3G Ex nA II T3	0.18	2.53	680	IE3- 58.7	56.3	49.8	0.61	0.73	2.6	1.6	1.6	2.0	IBExU06ATEXB002	0.00175	12
IE3-KPR 80 G8 Ex II 3G Ex nA II T3	0.25	3.39	705	IE3- 64.1	64.3	58.4	0.59	0.93	3.0	1.4	1.4	2.1	IBExU06ATEXB001	0.003	14
IE3-KPER 90 SY8 Ex II 3G Ex nA II T3	0.37	5.01	705	IE3- 69.3	67.0	61.2	0.56	1.39	3.1	1.6	1.6	2.2	IBExU06ATEXB002	0.00375	18.5
IE3-KPR 90 S8 Ex II 3G Ex nA II T3	0.37	4.98	710	IE3- 69.3	69.0	64.4	0.63	1.2	3.6	2.1	2.1	2.3	IBExU06ATEXB001	0.00625	25
IE3-KPR 90 L8 Ex II 3G Ex nA II T3	0.55	7.5	700	IE3- 73.0	70.6	66.3	0.64	1.72	3.6	1.8	1.8	2.3	IBExU06ATEXB001	0.0072	26
IE3-KPR 100 LY8 Ex II 3G Ex nA II T3	0.75	10.1	710	IE3- 75.0	74.1	70.0	0.64	2.21	4.2	2.0	2.0	2.7	IBExU06ATEXB001	0.009	28
IE3-KPR 100 L8 Ex II 3G Ex nA II T3	0.75	10	715	IE3- 75.0	75.9	71.3	0.63	2.25	4.4	2.5	2.5	2.8	IBExU06ATEXB001	0.0123	33.5
IE3-KPR 100 LW8 Ex II 3G Ex nA II T3	1.1	***	***	IE3- 77.7	***	***	***	***	***	***	***	***	IBExU06ATEXB001	***	***
IE3-KPR 100 LX8 Ex II 3G Ex nA II T3	1.1	14.8	710	IE3- 77.7	77.5	73.7	0.63	3.2	4.2	1.9	1.8	2.5	IBExU06ATEXB001	0.0139	36
IE3-KPER 112 M8 Ex II 3G Ex nA II T3	1.5	20.46	700	IE3- 79.7	78.7	76.0	0.65	4.25	3.8	1.6	1.5	2.1	IBExU06ATEXB002	0.0155	48
IE3-KPER 112 MZ8 Ex II 3G Ex nA II T3	1.5	20.3	705	IE3- 79.7	78.8	75.8	0.66	4.15	4.7	2.7	2.7	3.2	IBExU06ATEXB002	0.018	50
IE3-W41R 132 S8 Ex nA IIC T3	2.2	29	725	IE3- 84.4	84.5	82.4	0.7	5.4	4.1	1.6	1.5	2.3	IBExU03ATEXB004	0.043	80
IE3-W41R 132 M8 Ex nA IIC T3	3	40	720	IE3- 83.5	83.5	81.4	0.72	7	3.9	1.6	1.4	2.1	IBExU03ATEXB004	0.043	74
IE3-W41R 160 M8 Ex nA IIC T3	4	52	735	IE3- 87	86.7	83.8	0.71	9.4	5.4	2.5	2.2	2.9	IBExU03ATEXB004	0.113	119
IE3-W41R 160 MX8 Ex nA IIC T3	5.5	72	730	IE3- 87.5	87.5	85.6	0.73	12.5	4.7	1.9	1.7	2.5	IBExU03ATEXB004	0.145	143
IE3-W41R 160 L8 Ex nA IIC T3	7.5	98	733	IE3- 87.9	87.6	85.6	0.73	17	5.1	2.1	1.8	2.7	IBExU03ATEXB004	0.166	155
IE3-W41R 180 L8 Ex nA IIC T3	11	145	725	IE3- 89.3	89	87.1	0.75	23.5	5.4	2.1	1.9	2.8	IBExU03ATEXB004	0.228	175
IE3-W41R 200 L8 Ex nA IIC T3	15	196	730	IE3- 89.6	90	89	0.80	30	5.3	1.8	1.7	2.5	IBExU03ATEXB004	0.324	235
IE3-W41R 225 S8 Ex nA IIC T3	18.5	240	735	IE3- 90.1									IBExU03ATEXB004	0.514	310
IE3-W41R 225 M8 Ex nA IIC T3	22	286	735	IE3- 91.5	91.6	90.6	0.79	44	5.7	2.3	2	2.5	IBExU03ATEXB004	0.825	360
IE3-W41R 250 M8 Ex nA IIC T3	30	391	732	IE3- 91.3	91.9	91.4	0.81	58.5	5.4	2	1.8	2.3	IBExU03ATEXB004	0.92	420
IE3-W41R 280 S8 Ex nA IIC T3	37	479	738	IE3- 92	92	90.8	0.78	74.5	5.9	2.3	1.8	2.4	IBExU03ATEXB004	1.55	555
IE3-W41R 280 M8 Ex nA IIC T3	45	581	740	IE3- 93	93	92.4	0.78	89.5	6.5	1.7	1.5	2.4	IBExU03ATEXB004	2.63	700
IE3-W41R 315 S8 Ex nA IIC T3	55	707	743	IE3- 93.3	93.3	92.4	0.78	109	7.0	1.9	1.7	2.5	IBExU03ATEXB004	3.33	805
IE3-W41R 315 M8 Ex nA IIC T3	75	965	742	IE3- 93.8	94.2	93.8	0.81	142	7.0	1.9	1.7	2.3	IBExU03ATEXB004	5.55	1120
IE3-W41R 315 MX8 Ex nA IIC T3	90	1157	743	IE3- 94.3	94.4	93.6	0.8	172	7.9	2.4	2.0	2.7	IBExU03ATEXB004	6	1185
IE3-W41R 315 MY8 Ex nA IIC T3	110	1419	740	IE3- 93.8	94.0	93.8	0.82	206	6.5	1.9	1.5	2.1	IBExU03ATEXB004	6.76	1250
IE3-W41R 315 L8 Ex nA IIC T3	132	1703	740	IE3- 94.2	94.2	93.5	0.8	253	8.0	2.4	1.9	2.7	IBExU03ATEXB004	8.71	1450
IE3-W41R 355 MY8 Ex nA IIC T3	160	2051	745	IE3- 94.3	94.3	94.0	0.82	299	6.6	1.2	1.0	2.6	IBExU03ATEXB004	9.3	1700
IE3-W41R 355 M8 Ex nA IIC T3	200	2564	745	IE3- 94.7	94.9	94.2	0.81	376	7.0	1.0	1.0	2.7	IBExU03ATEXB004	9.5	1890
IE3-W41R 355 MX8 Ex nA IIC T3	230	2948	745	IE3- 95.2	95.2	95.0	0.83	420	7.0	1.2	1.0	2.6	IBExU03ATEXB004	13.40	2200
IE3-W41R 355 L8 Ex nA IIC T3	250	3205	745	IE3- 94.8	94.1	91.5	0.78	488					IBExU03ATEXB004	15.80	2400
IE3-W42R 355 MX8 Ex nA IIC	160	2054	744	IE3- 95.4	95.0	94.0	0.8	303	6.8	1.3	1.0	2.5		13.4	2200
IE3-W42R 355 L8 Ex nA IIC	200	2570	743	IE3- 95.6	95.5	94.0	0.77	393	6.5	1.6	1.0	2.7		15.8	2400
IE3-W42R 355 LX8 Ex nA IIC	250	3213	743	IE3- 95.6	95.4	93.8	0.78	487	6.4	2.5	1.9	2.5		15.8	2400
IE3-W42R 400 MY8 Ex nA IIC	315	4048	743	IE3- 95.6	95.5	94.5	0.78	611	6.4	2.5	1.9	2.5		17.94	3000
IE3-W42R 400 M8 Ex nA IIC	355	4550	745	IE3- 95.6	95.5	94.5	0.76	708	6.6	1.9	1.7	2.3		17.94	3000
IE3-W42R 400 MX8 Ex nA IIC	400	5134	744	IE3- 95.6	95.6	94.6	0.73	831	6.1	1.8	1.7	1.9		19.99	3150
IE3-W42R 400 L8 Ex nA IIC	450	5776	744	IE3- 95.6	95.6	94.6	0.72	947	6.4	2.0	1.7	2.0		22.34	3300

Optionally in dust-protected version, protection type: Protection by enclosure "tc" to EN 60079-31, double marking on rating plate.
 Other voltages and frequencies upon request. Changes are possible for motors which are not yet certified.
 **) upon request

Three-phase motors with squirrel-cage rotor, High Efficiency IE2
Type of explosion protection „n“ (Increased safety „ec“)
for operation in Zone 2 according to EN 60079-15 (EN 60079-7)

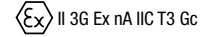

for rated voltage, temperature classes T1, T2 and T3
with surface cooling, duty type S1, continuous duty
thermal class F, degree of protection IP 55, 50 Hz

Motor selection data													Design point 400 V, 50 Hz		
Type	P	M _B	n _B	η _B			cosφ _B	I _B	I _A /I _B	M _A /M _B	M _S /M _B	M _K /M _B	Certificate no. IBEJU...	J	m
	kW	Nm	rpm	100 %	75 %	50 %	-	A	-	-	-	-		kgm ²	kg
Synchronous speed 3000 rpm – 2-pole version															
IE2-KPER 56 G2 Ex nA IIC T3	0.12	0.4	2830	IE2- 53.6	69.6	60.8	0.77	0.32	4.5	2.1	2.1	2.3	IBExU06ATEXB002	0.00013	4.5
IE2-KPR 56 G2 Ex nA IIC T3	0.12	0.41	2810	IE2- 53.6	65.5	61.6	0.83	0.31	4.7	2.0	2.0	2.2	IBExU06ATEXB001	0.00015	4.8
IE2-KPER 63 K2 Ex nA IIC T3	0.18	0.62	2790	IE2- 60.4	63.1	57.6	0.76	0.51	4.1	1.9	1.9	2.2	IBExU06ATEXB002	0.00013	4.9
IE2-KPR 63 K2 Ex nA IIC T3	0.18	0.61	2840	IE2- 60.4	68.6	63.5	0.84	0.44	5.5	2.5	2.4	2.9	IBExU06ATEXB001	0.00025	6.3
IE2-KPER 63 G2 Ex nA IIC T3	0.25	0.86	2775	IE2- 64.8	66.7	61.9	0.8	0.67	4.2	1.9	1.9	2.2	IBExU06ATEXB002	0.00015	5.2
IE2-KPR 63 G2 Ex nA IIC T3	0.25	0.83	2860	IE2- 64.8	77.6	73.6	0.84	0.55	6.2	2.6	2.5	2.8	IBExU06ATEXB001	0.00032	7
IE2-KPER 71 K2 Ex nA IIC T3	0.37	1.28	2750	IE2- 69.5	70.8	69.4	0.84	0.89	4.6	1.8	1.8	2.1	IBExU06ATEXB002	0.00025	6.7
IE2-KPR 71 K2 Ex nA IIC T3	0.37	1.24	2860	IE2- 69.5	74.2	72.7	0.87	0.78	7.1	2.9	2.7	3.1	IBExU06ATEXB001	0.00057	10
IE2-KPER 71 G2 Ex nA IIC T3	0.55	1.89	2775	IE2- 74.1	75.0	72.0	0.81	1.32	5.1	2.3	2.1	2.6	IBExU06ATEXB002	0.00032	7.6
IE2-KPR 71 G2 Ex nA IIC T3	0.55	1.83	2870	IE2- 74.1	78.3	75.4	0.86	1.14	7.4	3.0	2.7	3.3	IBExU06ATEXB001	0.00072	11.2
IE2-KPER 80 K2 Ex nA IIC T3	0.75	2.54	2825	IE2- 77.4	77.1	72.9	0.81	1.72	5.9	2.4	2.4	2.4	IBExU06ATEXB002	0.00057	10.7
IE2-KPR 80 K2 Ex nA IIC T3	0.75	2.49	2880	IE2- 77.4	83.6	81.6	0.88	1.48	7.7	2.2	2.1	2.7	IBExU06ATEXB001	0.00132	15
IE2-KPER 80 G2 Ex nA IIC T3	1.1	3.75	2805	IE2- 79.6	78.7	76.4	0.85	2.36	5.6	1.9	1.8	2.2	IBExU06ATEXB002	0.00072	11.5
IE2-KPR 80 G2 Ex nA IIC T3	1.1	3.64	2885	IE2- 79.6	82.1	81.2	0.89	2.15	7.8	2.5	2.3	2.8	IBExU06ATEXB001	0.0017	18
IE2-KPER 90 S2 Ex nA IIC T3	1.5	4.99	2870	IE2- 81.3	82.0	79.4	0.8	3.3	6.6	3.2	3.2	3.7	IBExU06ATEXB002	0.00132	16
IE2-KPR 90 S2 Ex nA IIC T3	1.5	4.92	2910	IE2- 81.3	85.5	82.9	0.87	2.9	9.0	2.8	2.4	3.4	IBExU06ATEXB001	0.00275	23.5
IE2-KPER 90 L2 Ex nA IIC T3	2.2	7.37	2850	IE2- 83.2	81.5	***	0.85	4.55	7.5	2.8	2.3	2.9	IBExU06ATEXB002	0.0017	19
IE2-KPR 90 L2 Ex nA IIC T3	2.2	7.29	2880	IE2- 83.2	85.7	83.9	0.88	4.25	8.0	2.5	2.3	2.9	IBExU06ATEXB001	0.00275	23.5
IE2-KPER 100 LY2 Ex nA IIC T3	3	9.97	2875	IE2- 84.6	85.1	83.6	0.85	6	7.4	2.6	2.3	3.3	IBExU06ATEXB002	0.00303	***
IE2-KPR 100 L2 Ex nA IIC T3	3	9.78	2930	IE2- 84.6	86.2	83.5	0.76	6.55	8.5	2.6	2.4	3.8	IBExU06ATEXB001	0.0045	31
IE2-KPER 112 M2 Ex nA IIC T3	4	13.2	2900	IE2- 85.8	86.3	***	0.81	8.4	7.0	2.2	2.1	2.9	IBExU06ATEXB002	0.0045	32
IE2-KPR 112 MX2 Ex nA IIC T3	4	13.08	2920	IE2- 85.8	86.4	85.8	0.84	7.9	8.3	2.3	2.1	3.3	IBExU06ATEXB002	0.0055	38
IE2-KPER 112 ML2 Ex nA IIC T3	5.5	18.2	2890	IE2- 85.9	86.6	***	0.84	11	7.5	2.4	2.2	3.0	IBExU06ATEXB002	0.0055	38
IE2-KPR 112 MV2 Ex nA IIC T3	5.5	18.11	2900	IE2- 87.0	88.7	88.8	0.88	10.3	7.8	2.0	1.9	2.7	IBExU06ATEXB002	0.0068	46
IE2-KPER 132 SY2T Ex nA IIC T3	5.5	18.2	2890	IE2- 87.0	86.6	***	0.84	11	7.5	2.4	2.2	3.0	IBExU06ATEXB002	0.0055	40
IE2-KPR 132 S2T Ex nA IIC T3	5.5	18.11	2900	IE2- 87.0	88.7	88.8	0.88	10.3	7.8	2.0	1.9	2.7	IBExU06ATEXB002	0.0068	48
IE2-KPER 112 MW2 Ex nA IIC T3	7.5	24.9	2880	IE2- 88.1	88.0	***	0.84	14.8	6.3	1.5	1.2	2.6	IBExU06ATEXB002	0.0068	46
IE2-KPR 132 SX2T Ex nA IIC T3	7.5	24.9	2880	IE2- 88.1	88.0	***	0.84	14.8	6.3	1.5	1.2	2.6	IBExU06ATEXB002	0.0068	48
IE2-WE1R 132 S2 Ex nA IIC T3	5.5	18.0	2915	IE2- 88.7	88.7	87.8	0.85	10.5	6.8	1.9	1.5	3.0	IBExU03ATEXB004	0.0110	57
IE2-WE1R 132 SX2 Ex nA IIC T3	7.5	24.5	2925	IE2- 88.8	89.2	88.3	0.91	13.5	6.7	2.1	1.6	2.9	IBExU03ATEXB004	0.0168	75
IE2-WE1R 160 M2 Ex nA IIC T3	11.0	35.6	2950	IE2- 90.3	90.3	89.1	0.90	19.5	7.7	2.3	1.7	3.1	IBExU03ATEXB004	0.0258	125
IE2-WE1R 160 MX2 Ex nA IIC T3	15.0	48.7	2940	IE2- 90.7	90.5	89.1	0.92	26	6.7	1.8	1.4	2.6	IBExU03ATEXB004	0.0675	140
IE2-WE1R 160 L2 Ex nA IIC T3	18.5	60.2	2935	IE2- 91.0	91.4	91.4	0.91	32	7.2	2.0	1.5	2.8	IBExU03ATEXB004	0.0675	140
IE2-WE1R 180 M2 Ex nA IIC T3	22	72	2935	IE2- 91.3	90.6	86.4	0.90	38.5	6.2	1.4	1.1	2.4	IBExU03ATEXB004	0.105	173
IE2-WE1R 200 L2 Ex nA IIC T3	30	97	2945	IE2- 92.0	91.3	90.5	0.91	52	6.9	1.7	1.3	2.6	IBExU03ATEXB004	0.128	210
IE2-WE1R 200 LX2 Ex nA IIC T3	37	120	2940	IE2- 92.5	92.3	91.6	0.92	63	7.4	1.9	1.4	2.9	IBExU03ATEXB004	0.154	233
IE2-WE2R 200 LX2 Ex nA IIC T3	37	120	2940	IE2- 92.5	92.3	91.6	0.92	63	7.4	1.9	1.4	2.9	IBExU03ATEXB004	0.154	233
IE2-WE1R 225 M2 Ex nA IIC T3	45	146	2950	IE2- 92.9	92.2	91.2	0.87	80.5	6.9	1.7	1.1	2.7	IBExU03ATEXB004	0.220	295
IE2-WE1R 250 M2 Ex nA IIC T3	55	178	2955	IE2- 93.5	93.7	93.2	0.89	95.5	8.2	2.3	1.9	2.8	IBExU03ATEXB004	0.375	385
IE2-WE1R 280 S2 Ex nA IIC T3	75	241	2970	IE2- 94.1	94.0	91.5	0.90	128	7.9	2.1	1.7	3.0	IBExU03ATEXB004	0.65	500
IE2-WE1R 280 M2 Ex nA IIC T3	90	289	2970	IE2- 94.4	94.1	91.9	0.91	151	7.7	2.0	1.7	2.8	IBExU03ATEXB004	0.68	550
IE2-WE1R 315 S2 Ex nA IIC T3	110	353	2975	IE2- 94.5	94.3	93.3	0.89	189	8.0	1.3	1.2	2.4	IBExU03ATEXB004	1.21	730
IE2-WE1R 315 M2 Ex nA IIC T3	132	424	2975	IE2- 95.0	94.8	94.5	0.89	225	9.2	1.4	1.2	2.4	IBExU03ATEXB004	1.44	820
IE2-WE1R 315 MX2 Ex nA IIC T3	160	514	2973	IE2- 94.8	94.8	94.8	0.89	274	8.2	1.3	1.3	2.4	IBExU03ATEXB004	1.76	955
IE2-WE1R 315 MY2 Ex nA IIC T3	200	640	2983	IE2- 95.4	95.0	94.3	0.88	344	9.4	2.8	2.0	3.0	IBExU03ATEXB004	2.82	1200
IE2-WE1R 315 L2 Ex nA IIC T3	250	800	2984	IE2- 95.4	95.4	95.4	0.92	411	9.0	2.3	1.2	2.3	IBExU03ATEXB004	3.66	1450
IE2-WE1R 315 LX2 Ex nA IIC T3	315	1008	2985	IE2- 95.4	95.4	95.0	0.92	518	8.5	2.8	1.6	2.5	IBExU03ATEXB004	4.43	1700
IE2-WE2R 355 M2G Ex nA IIC T3	355	1136	2985	IE2- 95.5	95.5	95.5	0.92	583	7.7	1.3	1.0	2.6	IBExU03ATEXB004	4.20	2000
IE2-WE2R 355 MX2G Ex nA IIC T3	400	1278	2990	IE2- 95.5	95.5	95.5	0.91	664	9.4	1.8	1.0	3.0	IBExU03ATEXB004	4.50	2200
IE2-WE2R 355 LY2G Ex nA IIC T3	450	1440	2985	IE2- 95.5	95.5	95.5	0.92	739	7.0	1.3	0.9	2.4	IBExU03ATEXB004	7.10	2400
IE2-WE2R 355 L2G Ex nA IIC T3	500	1597	2990	IE2- 95.5	95.5	95.5	0.92	821	8.5	1.5	1.2	2.5	IBExU03ATEXB004	7.10	2400

Optionally in dust-protected version, protection type: Protection by enclosure "tc" to EN 60079-31, double marking on rating plate.
Other voltages and frequencies upon request. Changes are possible for motors which are not yet certified.
*** upon request

**Three-phase motors with squirrel-cage rotor, High Efficiency IE2
Type of explosion protection „n“ (Increased safety „ec“)
for operation in Zone 2 according to EN 60079-15 (EN 60079-7)**

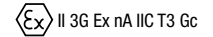

for rated voltage, temperature classes T1, T2 and T3
with surface cooling, duty type S1, continuous duty
thermal class F, degree of protection IP 55, 50 Hz

Motor selection data													Design point 400 V, 50 Hz		
Type	P kW	M _B Nm	n _B rpm	η _B (IEC/EN 60034-30-1)			cosφ _B -	I _B 400 V A	I _A /I _B -	M _A /M _B -	M _S /M _B -	M _K /M _B -	Certificate no. IBExU...	J kgm ²	m kg
				100 %	75 %	50 %									
Synchronous speed 1500 rpm – 4-pole version															
IE2-KPER 63 K4 Ex nA IIC T3	0.12	0.83	1380	IE2- 59.1	55.7	46.8	0.69	0.45	2.8	1.6	1.6	2.1	IBExU06ATEXB002	0.00019	4.8
IE2-KPR 63 K4 Ex nA IIC T3	0.12	0.82	1400	IE2- 59.1	69.1	63.9	0.71	0.35	3.8	2.0	1.9	2.3	IBExU06ATEXB001	0.0004	6.3
IE2-KPR 63 GY4 Ex nA IIC T3	0.18	1.23	1395	IE2- 64.7	66.3	61.3	0.72	0.54	3.5	1.7	1.7	2.2	IBExU06ATEXB001	0.0004	6.3
IE2-KPR 63 G4 Ex nA IIC T3	0.18	1.21	1425	IE2- 64.7	66.6	60.7	0.64	0.57	4.4	1.8	1.8	2.7	IBExU06ATEXB001	0.0005	7.1
IE2-KPER 71 K4 Ex nA IIC T3	0.25	1.71	1395	IE2- 68.5	68.1	63.8	0.7	0.73	3.9	2.1	2.1	2.5	IBExU06ATEXB002	0.0005	7.8
IE2-KPR 71 K4 Ex nA IIC T3	0.25	1.67	1430	IE2- 68.5	76.6	73.0	0.71	0.66	5.6	2.5	2.3	2.9	IBExU06ATEXB001	0.00087	9.9
IE2-KPR 71 GY4 Ex nA IIC T3	0.37	2.48	1425	IE2- 72.7	72.2	68.6	0.69	1	4.9	2.4	2.4	3.0	IBExU06ATEXB001	0.00087	9.9
IE2-KPR 71 G4 Ex nA IIC T3	0.37	2.47	1430	IE2- 72.7	78.2	73.1	0.69	0.98	6.2	2.8	2.6	3.2	IBExU06ATEXB001	0.00107	11
IE2-KPER 80 K4 Ex nA IIC T3	0.55	3.71	1415	IE2- 77.1	77.1	73.9	0.72	1.42	4.9	2.6	2.5	2.8	IBExU06ATEXB002	0.00107	11.7
IE2-KPR 80 K4 Ex nA IIC T3	0.55	3.67	1430	IE2- 77.1	79.6	78.7	0.8	1.25	6.0	2.4	2.3	2.7	IBExU06ATEXB001	0.00207	14.5
IE2-KPR 80 GY4 Ex nA IIC T3	0.75	5.01	1430	IE2- 79.6	78.0	74.7	0.8	1.73	5.7	2.2	2.2	3.1	IBExU06ATEXB001	0.00207	14.5
IE2-KPR 80 G4 Ex nA IIC T3	0.75	5.01	1430	IE2- 79.6	81.4	79.6	0.81	1.65	7.0	2.9	2.8	3.2	IBExU06ATEXB001	0.0026	17
IE2-KPER 90 S4 Ex nA IIC T3	1.1	7.32	1435	IE2- 81.4	80.1	77.0	0.76	2.6	6.3	3.0	3.0	3.8	IBExU06ATEXB002	0.0028	18.5
IE2-KPR 90 S4 Ex nA IIC T3	1.1	7.32	1435	IE2- 81.4	82.3	80.4	0.8	2.42	6.8	2.4	2.2	2.9	IBExU06ATEXB001	0.004	23
IE2-KPR 90 LW4 Ex nA IIC T3	1.5	9.95	1440	IE2- 82.8	83.8	81.4	0.76	3.4	6.5	2.7	2.7	3.6	IBExU06ATEXB001	0.004	23
IE2-KPR 90 L4 Ex nA IIC T3	1.5	9.91	1445	IE2- 82.8	83.2	80.7	0.77	3.35	7.2	3.2	3.0	3.5	IBExU06ATEXB001	0.0045	28
IE2-KPR 100 S4 Ex nA IIC T3	2.2	14.5	1445	IE2- 84.3	84.9	82.7	0.79	4.67	7.3	2.7	2.5	3.1	IBExU06ATEXB001	0.00725	30
IE2-KPR 100 L4 Ex nA IIC T3	2.2	14.4	1455	IE2- 84.3	85.2	81.7	0.77	4.8	9.3	3.2	3.0	3.6	IBExU06ATEXB001	0.009	36
IE2-KPR 100 LW4 Ex nA IIC T3	3	19.8	1445	IE2- 85.5	85.8	83.6	0.79	6.33	7.8	3.0	2.9	3.6	IBExU06ATEXB001	0.009	36
IE2-KPR 100 LX4 Ex nA IIC T3	3	19.7	1455	IE2- 85.5	86.3	84.5	0.77	6.5	9.0	3.3	3.1	3.9	IBExU06ATEXB001	0.011	45
IE2-KPER 112 MZ4 Ex nA IIC T3	4	26.4	1445	IE2- 86.6	87.0	85.0	0.8	8.3	8.2	2.8	2.6	3.6	IBExU06ATEXB002	0.013	50
IE2-WE1R 112 M4 Ex nA IIC T3	4.0	26.2	1460	IE2- 86.6	88.0	86.9	0.86	7.6	8.3	2.6	2.3	3.9	IBExU03ATEXB004	0.017	56
IE2-WE1R 132 S4 Ex nA IIC T3	5.5	35.7	1470	IE2- 89.8	89.9	88.4	0.87	10	7.4	2.3	1.9	3.4	IBExU03ATEXB004	0.035	87
IE2-WE2R 132 S4 Ex nA IIC T3	5.5	36.2	1450	IE2- 88.4	89.3	89.0	0.87	10.5	7.7	2.3	1.8	3.5	IBExU03ATEXB004	0.020	64
IE2-WE1R 132 M4 Ex nA IIC T3	7.5	48.7	1470	IE2- 89.9	90.0	88.5	0.82	14.5	8.5	2.6	2.1	4.0	IBExU03ATEXB004	0.035	88
IE2-WE1R 160 M4 Ex nA IIC T3	11.0	71	1475	IE2- 90.6	90.3	88.5	0.82	21.5	8.1	3.1	2.4	3.4	IBExU03ATEXB004	0.078	122
IE2-WE2R 160 M4 Ex nA IIC T3	11	71.5	1470	IE2- 90.3	90.3	88.5	0.78	22.5	7.8	2.4	2.1	3.9	IBExU03ATEXB004	0.043	105
IE2-WE1R 160 L4 Ex nA IIC T3	15.0	97	1470	IE2- 90.6	90.9	90.5	0.87	27.5	8.3	2.7	2.2	3.2	IBExU03ATEXB004	0.115	160
IE2-WE2R 160 L4 Ex nA IIC T3	15	97	1480	IE2- 92.0	92.0	90.6	0.84	28	9.1	3.0	2.5	3.9	IBExU03ATEXB004	0.115	161
IE2-WE1R 180 M4 Ex nA IIC T3	18.5	120	1475	IE2- 91.5	91.5	90.4	0.86	34	6.8	1.8	1.5	2.7	IBExU03ATEXB004	0.168	207
IE2-WE2R 180 M4 Ex nA IIC T3	18.5	120	1470	IE2- 91.2	90.6	89.3	0.78	37.5	6.4	2.0	1.6	2.8	IBExU03ATEXB004	0.138	176
IE2-WE1R 180 L4 Ex nA IIC T3	22	142	1475	IE2- 91.6	91.4	89.9	0.83	42	7.3	2.1	1.7	3.0	IBExU03ATEXB004	0.168	215
IE2-WE1R 200 L4 Ex nA IIC T3	30	194	1480	IE2- 92.3	91.3	88.2	0.80	58.5	7.3	2.1	1.7	2.9	IBExU03ATEXB004	0.275	277
IE2-WE1R 225 S4 Ex nA IIC T3	37	240	1475	IE2- 92.7	91.8	90.7	0.84	68.5	7.4	2.2	1.7	2.7	IBExU03ATEXB004	0.313	313
IE2-WE1R 225 M4 Ex nA IIC T3	45	290	1483	IE2- 93.1	93.0	91.1	0.84	83	7.9	2.3	1.9	2.4	IBExU03ATEXB004	0.525	390
IE2-WE2R 225 M4 Ex nA IIC T3	45	291	1475	IE2- 93.1	92.9	92.1	0.80	87	7.6	2.6	1.9	3.1	IBExU03ATEXB004	0.356	346
IE2-WE1R 250 M4 Ex nA IIC T3	55	354	1485	IE2- 94.0	94.1	92.5	0.84	101	8.0	2.0	1.7	2.3	IBExU03ATEXB004	0.95	535
IE2-WE2R 250 M4 Ex nA IIC T3	55	356	1477	IE2- 93.9	93.8	93.7	0.82	103	7.5	2.4	1.9	2.4	IBExU03ATEXB004	0.62	435
IE2-WE1R 280 S4 Ex nA IIC T3	75	482	1485	IE2- 94.2	94.4	92.1	0.84	137	7.2	1.8	1.6	2.1	IBExU03ATEXB004	0.95	550
IE2-WE1R 280 M4 Ex nA IIC T3	90	580	1483	IE2- 94.3	94.5	94.0	0.84	164	7.6	1.8	1.6	2.3	IBExU03ATEXB004	1.10	610
IE2-WE1R 315 S4 Ex nA IIC T3	110	707	1485	IE2- 94.8	94.8	94.0	0.82	204	8.5	1.8	1.5	2.7	IBExU03ATEXB004	1.96	760
IE2-WE1R 315 M4 Ex nA IIC T3	132	849	1484	IE2- 95.0	95.0	94.5	0.83	242	8.2	1.8	1.6	2.3	IBExU03ATEXB004	2.27	850
IE2-WE1R 315 MX4 Ex nA IIC T3	160	1031	1482	IE2- 95.0	95.0	94.5	0.84	289	7.4	1.6	1.4	2.2	IBExU03ATEXB004	2.73	975
IE2-WE1R 315 MY4 Ex nA IIC T3	200	1282	1490	IE2- 95.1	95.1	94.5	0.87	349	8.5	1.8	1.6	2.5	IBExU03ATEXB004	4.82	1270
IE2-WE1R 315 L4 Ex nA IIC T3	250	1602	1490	IE2- 95.4	95.4	95.3	0.88	430	9.0	2.2	1.5	2.7	IBExU03ATEXB004	5.93	1450
IE2-WE1R 315 LX4 Ex nA IIC T3	315	2019	1490	IE2- 95.4	95.4	95.0	0.88	542	9.0	2.4	1.6	2.6	IBExU03ATEXB004	6.82	1630
IE2-WE2R 355 M4 Ex nA IIC T3	355	2271	1493	IE2- 95.5	95.5	95.0	0.87	617	8.0	1.3	1.0	2.7	IBExU03ATEXB004	7.90	2150
IE2-WE2R 355 MX4 Ex nA IIC T3	400	2557	1494	IE2- 95.5	95.5	95.5	0.88	687	8.5	1.3	1.0	3.0	IBExU03ATEXB004	9.50	2400
IE2-WE2R 355 L4 Ex nA IIC T3	450	2873	1496	IE2- 95.5	95.5	95.5	0.86	790	8.5	1.4	0.8	2.9	IBExU03ATEXB004	10.00	2500

Optionally in dust-protected version, protection type: Protection by enclosure "tc" to EN 60079-31, double marking on rating plate.
Other voltages and frequencies upon request. Changes are possible for motors which are not yet certified.

Three-phase motors with squirrel-cage rotor, High Efficiency IE2 Type of explosion protection „n“ (Increased safety „ec“) for operation in Zone 2 according to EN 60079-15 (EN 60079-7)

for rated voltage, temperature classes T1, T2 and T3
with surface cooling, duty type S1, continuous duty
thermal class F, degree of protection IP 55, 50 Hz

Motor selection data													Design point 400 V, 50 Hz		
Type	P	M _B	n _B	η _B			cosφ _B	I _B	I _A /I _B	M _A /M _B	M _S /M _B	M _K /M _B	Certificate no. IExU...	J	m
	kW	Nm	rpm	100 %	75 %	50 %	-	A	-	-	-	-	IBExU...	kgm ²	kg
Synchronous speed 1000 rpm – 6-pole version															
IE2-KPER 63 G6 Ex nA IIC T3	0.12	1.3	880	IE2- 50.6	48.0	***)	0.56	0.59	2.5	2.0	2.0	2.3	IBExU06ATEXB002	0.00027	5.7
IE2-KPER 71 K6 Ex nA IIC T3	0.18	1.87	920	IE2- 56.6	54.4	48.5	0.52	0.8	2.9	2.0	2.0	2.3	IBExU06ATEXB002	0.0006	8.3
IE2-KPR 71 K6 Ex nA IIC T3	0.18	1.85	930	IE2- 56.6	65.0	59.4	0.68	0.57	3.4	2.0	2.0	2.2	IBExU06ATEXB001	0.0013	11
IE2-KPER 71 G6 Ex nA IIC T3	0.25	2.61	915	IE2- 61.6	56.5	***)	0.55	1.1	2.9	2.0	2.0	2.2	IBExU06ATEXB002	0.0006	8.3
IE2-KPR 71 G6 Ex nA IIC T3	0.25	2.55	935	IE2- 61.6	69.9	65.0	0.67	0.75	3.9	2.3	2.3	2.5	IBExU06ATEXB001	0.00175	12.5
IE2-KPER 80 K6 Ex nA IIC T3	0.37	3.78	935	IE2- 67.6	68.5	63.3	0.65	1.17	3.7	2.1	2.1	2.6	IBExU06ATEXB002	0.00175	12.5
IE2-KPR 80 K6 Ex nA IIC T3	0.37	3.72	950	IE2- 67.6	73.5	69.7	0.7	1.03	4.0	1.9	1.9	2.4	IBExU06ATEXB001	0.00325	15
IE2-KPR 80 GY6 Ex nA IIC T3	0.55	5.56	945	IE2- 73.1	72.6	68.4	0.67	1.62	3.8	1.9	1.9	2.4	IBExU06ATEXB001	0.00325	15
IE2-KPR 80 G6 Ex nA IIC T3	0.55	5.53	950	IE2- 73.1	75.9	72.4	0.69	1.5	4.1	2.1	2.1	2.5	IBExU06ATEXB001	0.00425	18
IE2-KPER 90 S6 Ex nA IIC T3	0.75	7.58	945	IE2- 75.9	***)	***)	0.67	2.12	4.0	1.8	1.8	2.4	IBExU06ATEXB002	0.00425	19
IE2-KPR 90 S6 Ex nA IIC T3	0.75	7.5	955	IE2- 75.9	78.3	75.1	0.71	1.95	4.9	2.4	2.3	2.6	IBExU06ATEXB001	0.00625	24
IE2-KPR 90 LW6 Ex nA IIC T3	1.1	11	955	IE2- 78.1	78.0	75.1	0.69	2.95	4.7	2.5	2.4	2.8	IBExU06ATEXB001	0.00625	24
IE2-KPR 90 L6 Ex nA IIC T3	1.1	11	955	IE2- 78.1	82.0	79.3	0.71	2.75	5.4	2.5	2.4	2.8	IBExU06ATEXB001	0.0072	30
IE2-KPR 100 LW6 Ex nA IIC T3	1.1	10.94	960	IE2- 78.1	***)	***)	0.76	2.5	6.5	2.8	2.7	3.4	IBExU06ATEXB001	0.0139	36
IE2-KPER 100 L6 Ex nA IIC T3	1.5	15.08	950	IE2- 79.8	80.4	77.6	0.7	3.85	5.1	2.5	2.4	3.0	IBExU06ATEXB002	0.0072	30
IE2-KPR 100 LX6 Ex nA IIC T3	1.5	15	955	IE2- 79.8	83.5	81.5	0.76	3.45	5.9	2.3	2.2	2.8	IBExU06ATEXB001	0.0139	36
IE2-KPER 112 MX6 Ex nA IIC T3	2.2	21.89	960	IE2- 81.8	***)	***)	0.65	5.9	6.4	3.0	2.9	3.7	IBExU06ATEXB002	***)	37
IE2-KPER 112 MV6 Ex nA IIC T3	2.2	22	955	IE2- 81.8	82.5	79.8	0.75	5.15	5.7	2.4	2.3	2.9	IBExU06ATEXB002	0.0155	48
IE2-KPER 112 MZ6 Ex nA IIC T3	3	30	955	IE2- 83.3	83.1	80.5	0.75	6.85	6.5	2.8	2.7	3.5	IBExU06ATEXB002	0.043	50
IE2-KPER 132 SX6T Ex nA IIC T3	3	30	955	IE2- 83.3	83.1	80.5	0.73	7.1	7.0	3.2	3.1	4.0	IBExU06ATEXB002	0.0165	52
IE2-W21R 132 S6 Ex nA IIC T3	3.0	29.8	963	IE2- 84.9	85.2	83.9	0.80	6.4	6.0	2.0	1.3	3.0	IBExU03ATEXB004	0.023	55
IE2-W21R 132 M6 Ex nA IIC T3	4.0	39.6	965	IE2- 85.5	85.5	83.8	0.79	8.5	5.1	1.8	1.6	2.4	IBExU03ATEXB004	0.043	76
IE2-WE2R 132 M6 Ex nA IIC T3	4	40	955	IE2- 85.1	86.0	85.2	0.82	8.3	5.7	2.1	2.0	2.9	IBExU03ATEXB004	0.029	66
IE2-W21R 132 MX6 Ex nA IIC T3	5.5	54	970	IE2- 86.1	85.5	82.4	0.77	12	5.7	2.2	1.7	2.7	IBExU03ATEXB004	0.053	85
IE2-W21R 160 M6 Ex nA IIC T3	7.5	73	975	IE2- 87.4	88.1	86.0	0.81	15.5	6.3	2.5	2.1	2.9	IBExU03ATEXB004	0.113	118
IE2-WE2R 160 M6 Ex nA IIC T3	7.5	74	970	IE2- 87.5	87.6	85.9	0.79	15.5	5.9	2.1	1.8	2.9	IBExU03ATEXB004	0.053	103
IE2-W21R 160 L6 Ex nA IIC T3	11.0	108	970	IE2- 88.7	87.9	86.3	0.85	21	5.8	2.2	1.9	2.7	IBExU03ATEXB004	0.145	135
IE2-WE1R 160 L6 Ex nA IIC T3	11.0	108	975	IE2- 88.9	88.8	87.0	0.81	22	6.8	2.7	2.4	3.1	IBExU03ATEXB004	0.166	155
IE2-W21R 180 L6 Ex nA IIC T3	15.0	147	975	IE2- 89.7	88.8	86.7	0.84	28.5	6.2	2.1	1.8	2.8	IBExU03ATEXB004	0.228	185
IE2-WE2R 180 L6 Ex nA IIC T3	15	148	970	IE2- 89.7	88.8	87.8	0.83	29	5.6	2.3	1.7	2.6	IBExU03ATEXB004	0.166	157
IE2-WE1R 200 L6 Ex nA IIC T3	18.5	180	980	IE2- 90.4	88.8	86.5	0.85	35	6.6	2.3	1.7	2.9	IBExU03ATEXB004	0.268	208
IE2-WE1R 200 LX6 Ex nA IIC T3	22	214	980	IE2- 90.9	90.2	88.5	0.86	40.5	6.4	2.2	1.8	2.7	IBExU03ATEXB004	0.443	272
IE2-WE2R 200 LX6 Ex nA IIC T3	22	215	975	IE2- 90.9	89.9	88.5	0.84	41.5	6.7	2.4	2.0	3.0	IBExU03ATEXB004	0.324	238
IE2-WE1R 225 M6 Ex nA IIC T3	30	291	985	IE2- 92.0	91.5	90.0	0.86	54.5	7.3	2.5	2.2	2.9	IBExU03ATEXB004	0.825	365
IE2-WE2R 225 M6 Ex nA IIC T3	30	294	975	IE2- 91.7	91.4	90.6	0.87	54.5	6.7	2.3	1.9	2.8	IBExU03ATEXB004	0.514	308
IE2-WE1R 250 M6 Ex nA IIC T3	37	359	985	IE2- 92.2	91.7	90.7	0.85	68	6.4	2.7	1.8	2.4	IBExU03ATEXB004	1.28	480
IE2-WE2R 250 M6 Ex nA IIC T3	37	361	979	IE2- 92.2	92.3	91.8	0.86	67.5	6.6	2.7	2.0	2.6	IBExU03ATEXB004	0.92	407
IE2-WE1R 280 S6 Ex nA IIC T3	45	437	983	IE2- 93.0	92.7	92.4	0.87	80.5	6.5	2.2	1.7	2.4	IBExU03ATEXB004	1.48	560
IE2-WE1R 280 M6 Ex nA IIC T3	55	531	990	IE2- 93.5	93.5	93.0	0.85	100	7.6	2.0	1.5	2.5	IBExU03ATEXB004	2.63	710
IE2-WE1R 315 S6 Ex nA IIC T3	75	723	990	IE2- 93.9	93.7	93.5	0.87	133	7.8	1.9	1.5	2.5	IBExU03ATEXB004	3.33	804
IE2-WE1R 315 M6 Ex nA IIC T3	90	868	990	IE2- 94.0	94.0	93.5	0.88	157	7.5	1.8	1.5	2.5	IBExU03ATEXB004	3.60	865
IE2-WE1R 315 MX6 Ex nA IIC T3	110	1061	990	IE2- 94.3	94.3	94.0	0.87	194	7.5	1.8	1.4	2.3	IBExU03ATEXB004	6.67	1210
IE2-WE1R 315 MY6 Ex nA IIC T3	132	1273	990	IE2- 94.6	94.3	94.0	0.87	231	7.5	1.9	1.4	2.2	IBExU03ATEXB004	6.67	1250
IE2-WE1R 315 L6 Ex nA IIC T3	160	1543	990	IE2- 94.8	94.5	93.5	0.88	277	7.5	2.0	1.5	2.4	IBExU03ATEXB004	8.60	1430
IE2-WE1R 315 LX6 Ex nA IIC T3	200	1929	990	IE2- 95.0	95.0	94.5	0.86	353	7.0	1.9	1.5	2.2	IBExU03ATEXB004	8.60	1460
IE2-WE2R 355 M6 Ex nA IIC T3	200	1920	995	IE2- 95.0	95.0	94.0	0.82	371	8.0	1.7	1.4	2.6	IBExU03ATEXB004	8.20	1850
IE2-WE2R 355 MX6 Ex nA IIC T3	315	3023	995	IE2- 95.0	95.0	94.5	0.85	447	7.5	1.6	1.2	2.5	IBExU03ATEXB004	12.1	2200
IE2-WE2R 355 LY6 Ex nA IIC T3	355	3407	995	IE2- 95.3	95.3	95.3	0.86	555	8.0	2.1	1.3	2.6	IBExU03ATEXB004	14.0	2400

Optionally in dust-protected version, protection type: Protection by enclosure "tc" to EN 60079-31, double marking on rating plate.
Other voltages and frequencies upon request. Changes are possible for motors which are not yet certified.
***) upon request

**Three-phase motors with squirrel-cage rotor, High Efficiency IE2
Type of explosion protection „n“ (Increased safety „ec“)
for operation in Zone 2 according to EN 60079-15 (EN 60079-7)**

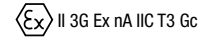

for rated voltage, temperature classes T1, T2 and T3
with surface cooling, duty type S1, continuous duty
thermal class F, degree of protection IP 55, 50 Hz

Motor selection data													Design point 400 V, 50 Hz		
Type	P kW	M _B Nm	n _B rpm	η _B (IEC/EN 60034-30-1)			cosφ _B -	I _B 400 V A	I _M /I _B -	M _M /M _B -	M _S /M _B -	M _K /M _B -	Certificate no. IBExU...	J kgm ²	m kg
				100 %	75 %	50 %									
Synchronous speed 750 rpm – 8-pole version															
IE2-KPER 71 G8 Ex nA IIC T3	0.12	1.71	670	IE2- 39.8	41.3	***)	0.51	0.73	2.3	1.8	1.8	2.1	IBExU06ATEXB002	0.0006	8.1
IE2-KPER 80 K8 Ex nA IIC T3	0.18	2.49	690	IE2- 45.9	53.8	***)	0.59	0.78	2.8	2.0	2.0	2.2	IBExU06ATEXB002	0.0013	10.5
IE2-KPER 80 G8 Ex nA IIC T3	0.25	3.44	695	IE2- 50.6	54.0	***)	0.56	1.12	3.0	2.3	2.3	2.5	IBExU06ATEXB002	0.00175	12
IE2-KPER 90 S8 Ex nA IIC T3	0.37	5.05	700	IE2- 56.1	56.3	***)	0.54	1.6	3.0	1.9	1.9	2.1	IBExU06ATEXB002	0.003	15
IE2-KPR 90 S8 Ex nA IIC T3	0.37	4.98	710	IE2- 56.1	70.3	65.7	0.63	1.2	3.6	2.1	2.1	2.3	IBExU06ATEXB001	0.00625	24
IE2-KPER 90 L8 Ex nA IIC T3	0.55	7.56	695	IE2- 61.7	61.8	***)	0.6	2.04	3.2	1.9	1.9	2.2	IBExU06ATEXB002	0.00375	18
IE2-KPR 90 L8 Ex nA IIC T3	0.55	7.5	700	IE2- 61.7	***)	***)	0.64	1.72	3.6	1.8	1.8	2.3	IBExU06ATEXB001	0.0072	26
IE2-KPER 100 L8 Ex nA IIC T3	0.75	10.2	705	IE2- 66.2	63.0	***)	0.6	2.9	3.3	1.8	1.8	2.2	IBExU06ATEXB002	0.00625	23
IE2-KPR 100 L8 Ex nA IIC T3	0.75	10.02	715	IE2- 66.2	75.9	71.3	0.63	2.25	4.4	2.5	2.5	2.8	IBExU06ATEXB001	0.0123	33.5
IE2-KPR 100 LY8 Ex nA IIC T3	1.1	14.9	705	IE2- 70.8	72.5	***)	0.67	3.25	4.0	2.0	2.0	2.4	IBExU06ATEXB001	0.009	28
IE2-KPR 100 LX8 Ex nA IIC T3	1.1	14.79	710	IE2- 70.8	78	74.2	0.63	3.2	4.2	1.9	1.8	2.5	IBExU06ATEXB001	0.0139	36
IE2-KPER 112 M8 Ex nA IIC T3	1.5	20.3	705	IE2- 74.1	73.6	70.1	0.62	4.5	4.2	2.0	2.0	2.7	IBExU06ATEXB002	0.0139	37
IE2-KPER 112 MV8 Ex nA IIC T3	1.5	20.46	700	IE2- 74.1	78.7	76.0	0.65	4.25	3.8	1.6	1.6	2.1	IBExU06ATEXB002	0.0155	48
IE2-WE1R 132 S8 Ex nA IIC T3	2.2	29.2	720	IE2- 81.7	81.0	77.5	0.65	6	4.8	2.2	2.0	3.2	IBExU03ATEXB004	0.0180	55
IE2-WE1R 132 M8 Ex nA IIC T3	3.0	39.8	720	IE2- 82.7	83.0	81.3	0.74	7.1	3.9	1.6	1.3	1.9	IBExU03ATEXB004	0.0430	74
IE2-WE2R 132 M8 Ex nA IIC T3	3	39.8	720	IE2- ***)	***)	***)	***)	***)	***)	***)	***)	***)	IBExU03ATEXB004	0.0290	65
IE2-WE1R 160 M8 Ex nA IIC T3	4.0	53.2	718	IE2- 84.2	83.7	81.9	0.72	9.5	4.6	1.6	***)	2.5	IBExU03ATEXB004	0.0530	86
IE2-WE1R 160 MX8 Ex nA IIC T3	5.5	72.0	730	IE2- 86.9	86.6	84.1	0.72	12.5	4.8	2.1	1.8	2.6	IBExU03ATEXB004	0.1130	115
IE2-WE2R 160 MX8 Ex nA IIC T3	5.5	73	715	IE2- 83.9	84.0	81.9	0.71	13.5	4.3	1.7	1.5	2.5	IBExU03ATEXB004	0.0530	103
IE2-WE1R 160 L8 Ex nA IIC T3	7.5	99	725	IE2- 87.5	87.0	83.5	0.77	16	5.5	2.0	***)	2.8	IBExU03ATEXB004	0.1450	136
IE2-WE1R 180 L8 Ex nA IIC T3	11.0	144	727	IE2- 88.2	88.2	86.7	0.78	23	4.9	1.8	1.6	2.4	IBExU03ATEXB004	0.2280	175
IE2-WE2R 180 L8 Ex nA IIC T3	11	144	730	IE2- 87.9	87.4	85.2	0.67	25.5	4.3	1.9	1.6	2.3	IBExU03ATEXB004	0.1660	157
IE2-WE1R 200 L8 Ex nA IIC T3	15.0	197	727	IE2- 88.2	88.1	86.4	0.77	32	4.9	1.9	1.7	2.3	IBExU03ATEXB004	0.2680	200
IE2-WE1R 225 S8 Ex nA IIC T3	18.5	242	730	IE2- 89.6	89.4	87.2	0.78	38	5.4	2.1	2.0	2.8	IBExU03ATEXB004	0.440	265
IE2-WE2R 225 S8 Ex nA IIC T3	18.5	240	735	IE2- 90.7	90.7	89.4	0.8	37	6.1	2.1	1.9	2.9	IBExU03ATEXB004	0.514	305
IE2-WE1R 225 M8 Ex nA IIC T3	22	287	733	IE2- 90.6	89.4	89.9	0.78	45	5.6	2.2	1.8	2.6	IBExU03ATEXB004	0.825	380
IE2-WE2R 225 M8 Ex nA IIC T3	22	286	735	IE2- 90.3	90.3	88.7	0.77	45.5	6.1	2.2	2.0	2.9	IBExU03ATEXB004	0.514	307
IE2-WE1R 250 M8 Ex nA IIC T3	30	389	737	IE2- 92.1	92.4	91.6	0.79	59.5	5.0	2.0	1.6	2.1	IBExU03ATEXB004	1.350	480
IE2-WE2R 250 M8 Ex nA IIC T3	30	391	732	IE2- 91.5	91.7	90.9	0.77	61.5	5.6	2.3	2.0	2.5	IBExU03ATEXB004	0.950	405
IE2-WE1R 280 S8 Ex nA IIC T3	37	479	737	IE2- 92.2	92.1	90.9	0.79	73.5	6.0	2.3	1.9	2.5	IBExU03ATEXB004	1.55	550
IE2-WE1R 280 M8 Ex nA IIC T3	45	581	740	IE2- 92.7	92.7	92.0	0.79	88.5	6.7	1.8	1.5	2.5	IBExU03ATEXB004	2.63	690
IE2-WE1R 315 S8 Ex nA IIC T3	55	710	740	IE2- 92.2	92.2	92.1	0.80	108	6.3	1.8	1.5	2.3	IBExU03ATEXB004	2.63	690
IE2-WE1R 315 M8 Ex nA IIC T3	75	968	740	IE2- 93.5	93.5	93.0	0.81	143	6.0	1.8	1.5	2.1	IBExU03ATEXB004	3.6	880
IE2-WE1R 315 MX8 Ex nA IIC T3	90	1161	740	IE2- 92.1	91.6	90.1	0.81	174	6.0	1.9	***)	2.2	IBExU03ATEXB004	6	1050
IE2-WE1R 315 MY8 Ex nA IIC T3	110	1420	740	IE2- 93.8	93.3	91.2	0.81	209	6.5	2.1	***)	2.4	IBExU03ATEXB004	6.76	1250
IE2-WE1R 315 L8 Ex nA IIC T3	132	1704	740	IE2- 94.4	94.0	93.5	0.83	243	7.5	2.2	1.8	2.5	IBExU03ATEXB004	8.71	1430
IE2-WE1R 315 LX8 Ex nA IIC T3	160	2065	740	IE2- 94.2	94.2	93.8	0.80	306	7.2	2.2	1.8	2.5	IBExU03ATEXB004	8.71	1430
IE2-WE2R 355 M8 Ex nA IIC T3	200	2571	743	IE2- 94.7	94.1	91.5	0.77	396	***)	***)	***)	***)	IBExU03ATEXB004	9.5	1850
IE2-WE2R 355 MX8 Ex nA IIC T3	250	3205	745	IE2- 95.8	95.8	95.5	0.83	454	7.0	1.2	1.0	2.6	IBExU03ATEXB004	13.4	2200
IE2-WE2R 355 LY8 Ex nA IIC T3	280	3599	743	IE2- 94.8	94.1	91.5	0.78	547	***)	***)	***)	***)	IBExU03ATEXB004	15.8	2400

Optionally in dust-protected version, protection type: Protection by enclosure "tc" to EN 60079-31, double marking on rating plate.
Other voltages and frequencies upon request. Changes are possible for motors which are not yet certified.
***) upon request

Three-phase motors with squirrel-cage rotor, Standard Efficiency IE1 Type of explosion protection „n“ (Increased safety „ec“) for operation in Zone 2 according to EN 60079-15 (EN 60079-7)

II 3G Ex nA IIC T3 Gc

for rated voltage, temperature classes T1, T2 and T3
with surface cooling, duty type S1, continuous duty
thermal class F, degree of protection IP 55, 50 Hz

Motor selection data													Design point 400 V, 50 Hz		
Type	P kW	M _B Nm	n _B rpm	η _B (IEC/EN 60034-30-1)			cosφ _B	I _B 400 V A	I _A /I _B	M _A /M _B	M _S /M _B	M _K /M _B	Certificate no. IBExU...	J kgm ²	m kg
				1.0	0.8	0.5									
Synchronous speed 3000 rpm – 2-pole version															
(IE1-)KPE0 56 K2 Ex nA IIC T3	0.09	0.3	2840	IE1- 70.2	68.1	64.5	0.74	0.25	4.9	2.3	2.3	2.8		0.00013	4.4
(IE1-)KPER 56 G2 Ex nA IIC T3	0.12	0.41	2830	IE1- 70.3	67.0	60.1	0.77	0.32	4.5	2.1	2.1	2.3		0.00013	4.5
(IE1-)KPER 63 K2 Ex nA IIC T3	0.18	0.62	2790	IE1- 67.0	65.6	59.8	0.76	0.51	4.1	1.9	1.9	2.2		0.00013	4.9
(IE1-)KPER 63 G2 Ex nA IIC T3	0.25	0.85	2800	IE1- 67.7	64.9	56.2	0.72	0.74	4.2	2.2	2.2	2.4		0.00015	5.2
(IE1-)KPER 71 K2 Ex nA IIC T3	0.37	1.27	2780	IE1- 71.9	70.8	65.0	0.79	0.94	4.4	2.1	2.1	2.3		0.00025	6.7
(IE1-)KPER 71 G2 Ex nA IIC T3	0.55	1.89	2775	IE1- 74.2	75.0	72.0	0.81	1.32	5.1	2.3	2.1	2.6		0.00032	7.6
(IE1-)KPER 80 K2 Ex nA IIC T3	0.75	2.54	2825	IE1- 76.8	77.5	74.3	0.82	1.72	5.9	2.4	2.4	2.4		0.00057	10.7
(IE1-)KPER 80 G2 Ex nA IIC T3	1.1	3.71	2835	IE1- 76.9	75.9	73.3	0.81	2.55	6.0	2.4	2.3	2.6		0.00072	11.5
(IE1-)KPER 90 S2 Ex nA IIC T3	1.5	5.04	2840	IE1- 81.2	82.2	80.3	0.86	3.1	7.0	2.5	2.5	2.8		0.00132	16.0
(IE1-)KPER 90 L2 Ex nA IIC T3	2.2	7.37	2850	IE1- 82.1	83.4	81.9	0.85	4.55	7.5	2.8	2.3	2.9		0.0017	19.0
(IE1-)KPER 100 L2 Ex nA IIC T3	3.0	10	2865	IE1- 82.8	83.1	83.3	0.85	6.15	6.8	2.4	2.2	2.8		0.00275	25.0
(IE1-)KPER 112 M2 Ex nA IIC T3	4.0	13.2	2900	IE1- 84.9	85.5	84.4	0.81	8.4	7.0	2.2	2.1	2.9		0.0045	32
(IE1-)KPER 112 MX2 Ex nA IIC T3	5.5	18.2	2890	IE1- 85.9	86.2	86.4	0.84	11.0	7.5	2.4	2.2	3.0		0.0055	40
(IE1-)KPER 132 S2T Ex nA IIC T3	5.5	18.2	2890	IE1- 85.9	86.2	86.4	0.84	11.0	7.5	2.4	2.2	3.0		0.0055	40
(IE1-)KPER 132 SX2T Ex nA IIC T3	7.5	24.9	2880	IE1- 87.1	87.2	86.6	0.84	14.8	6.3	1.5	1.2	2.6		0.0680	48
(IE1-)K11R 132 S2 Ex nA IIC T3	5.5	18	2860	IE1- 84.7	84.7	82.4	0.86	11	5.5	1.8	1.6	2.2	IBExU09ATEXB006	0.0081	50
(IE1-)K11R 132 SX2 Ex nA IIC T3	7.5	25	2900	IE1- 86.0	86.0	84.0	0.86	14.5	6.6	1.8	1.3	2.5	IBExU09ATEXB006	0.0110	59
(IE1-)K11R 160 M2 Ex nA IIC T3	11.0	36	2900	IE1- 87.6	87.6	84.6	0.90	20	7.0	2.4	2.0	3.0	IBExU09ATEXB006	0.0258	88
(IE1-)K11R 160 MX2 Ex nA IIC T3	15.0	49	2930	IE1- 88.7	88.7	85.8	0.90	27	7.1	2.2	1.7	2.9	IBExU09ATEXB006	0.0575	131
(IE1-)K11R 160 L2 Ex nA IIC T3	18.5	61	2920	IE1- 89.3	88.3	85.8	0.92	32.5	7.2	2.1	1.6	2.8	IBExU09ATEXB006	0.0675	138
(IE1-)K11R 180 M2 Ex nA IIC T3	22	72	2935	IE1- 89.9	89.1	86.1	0.92	38.5	6.8	1.7	1.4	2.6	IBExU09ATEXB006	0.105	178
(IE1-)K11R 200 L2 Ex nA IIC T3	30	97	2940	IE1- 91.1	90.3	88.8	0.92	51.5	7.3	2.0	1.6	2.9	IBExU09ATEXB006	0.128	207
(IE1-)K11R 200 LX2 Ex nA IIC T3	37	120	2940	IE1- 91.5	90.5	89.0	0.90	65	7.0	1.8	1.3	2.4	IBExU09ATEXB006	0.193	265
(IE1-)K11R 225 M2 Ex nA IIC T3	45	146	2940	IE1- 92.0	91.3	88.8	0.91	77.5	7.5	1.8	1.4	2.7	IBExU09ATEXB006	0.220	295
(IE1-)K11R 250 M2 Ex nA IIC T3	55	178	2955	IE1- 92.2	91.0	89.0	0.91	94.5	7.5	2.0	1.5	2.6	IBExU09ATEXB006	0.375	383
(IE1-)K11R 280 S2 Ex nA IIC T3	75	241	2970	IE1- 93.1	92.0	90.5	0.92	126	7.5	2.0	1.6	2.6	IBExU09ATEXB006	0.650	505
(IE1-)K11R 280 M2 Ex nA IIC T3	90	289	2970	IE1- 93.2	92.7	90.5	0.91	153	8.5	2.2	1.8	2.8	IBExU09ATEXB006	0.675	546
(IE1-)K11R 315 S2 Ex nA IIC T3	110	353	2975	IE1- 93.5	92.6	91.1	0.91	187	8.5	1.5	1.3	2.5	IBExU09ATEXB006	1.21	720
(IE1-)K11R 315 M2 Ex nA IIC T3	132	424	2975	IE1- 93.8	92.9	91.9	0.91	223	8.5	2.0	1.8	2.7	IBExU09ATEXB006	1.44	800
(IE1-)K11R 315 MX2 Ex nA IIC T3	160	514	2975	IE1- 94.0	94.0	94.0	0.91	270	8.5	1.5	1.0	2.0	IBExU09ATEXB006	1.76	980
(IE1-)K11R 315 MY2 Ex nA IIC T3	200	643	2970	IE1- 94.0	93.2	92.5	0.92	334	8.2	2.6	2.0	2.6	IBExU09ATEXB006	2.82	1170
(IE1-)K11R 315 L2 Ex nA IIC T3	250	803	2973	IE1- 94.1	93.2	93.0	0.93	412	7.3	2.1	1.4	2.0	IBExU09ATEXB006	3.66	1460
(IE1-)K11R 315 LX2 Ex nA IIC T3	315	1010	2980	IE1- 94.5	94.5	92.8	0.92	523	8.6	2.7	1.7	2.4	IBExU09ATEXB006	4.43	1630
(IE1-)K12R 355 MY2G Ex nA IIC T3	315	1007	2988	IE1- 94.5	94.3	93.7	0.88	547	8.6	1.3	1.0	3.0	IBExU09ATEXB006	4.10	1900
(IE1-)K12R 355 M2G Ex nA IIC T3	355	1138	2980	IE1- 94.3	94.3	93.8	0.91	597	7.3	1.3	1.0	2.3	IBExU09ATEXB006	4.20	2000
(IE1-)K12R 355 MX2G Ex nA IIC T3	400	1280	2985	IE1- 94.6	94.5	93.8	0.90	678	8.5	1.9	1.3	3.2	IBExU09ATEXB006	5.50	2200
(IE1-)K12R 355 L2G Ex nA IIC T3	450	1441	2983	IE1- 94.7	94.5	93.8	0.92	746	7.2	1.3	1.0	2.4	IBExU09ATEXB006	7.10	2400

Progressive series KPR/K10R possible upon request

Optionally in dust-protected version, protection type: Protection by enclosure "tc" to EN 60079-31, double marking on rating plate.

Other voltages and frequencies upon request. Changes are possible for motors which are not yet certified.

**Three-phase motors with squirrel-cage rotor, Standard Efficiency IE1
Type of explosion protection „n“ (Increased safety „ec“)
for operation in Zone 2 according to EN 60079-15 (EN 60079-7)**

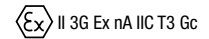

for rated voltage, temperature classes T1, T2 and T3
with surface cooling, duty type S1, continuous duty
thermal class F, degree of protection IP 55, 50 Hz

Motor selection data													Design point 400 V, 50 Hz		
Type	P kW	M _B Nm	n _B rpm	η _B (IEC/EN 60034-30-1)			cosφ _B -	I _B 400 V A	I _A /I _B -	M _A /M _B -	M _S /M _B -	M _K /M _B -	Certificate no. IBExU...	J	m
				1.0	0.8	0.5								kgm ²	kg
Synchronous speed 1500 rpm – 4-pole version															
(IE1-)KPE0 56 K4 Ex nA IIC T3	0.06	0.41	1410	IE1- 60.1	56.5	49.6	0.60	0.24	3.1	2.3	2.3	2.7		0.00019	4.3
(IE1-)KPER 56 G4 Ex nA IIC T3	0.09	0.63	1375	IE1- 61.6	58.7	53.0	0.68	0.31	3.2	1.9	1.9	2.2		0.00019	4.4
(IE1-)KPER 63 K4 Ex nA IIC T3	0.12	0.84	1370	IE1- 57.9	51.2	42.2	0.68	0.44	3.2	1.9	1.8	2.2		0.00019	4.8
(IE1-)KPER 63 G4 Ex nA IIC T3	0.18	1.26	1360	IE1- 60.6	57.5	49.4	0.66	0.65	3.3	2.0	2.0	2.3		0.00024	5.2
(IE1-)KPER 71 K4 Ex nA IIC T3	0.25	1.72	1385	IE1- 64.3	63.2	58.2	0.72	0.78	3.6	1.8	1.8	2.1		0.00040	6.8
(IE1-)KPER 71 G4 Ex nA IIC T3	0.37	2.58	1370	IE1- 68.1	66.7	62.0	0.74	1.06	3.8	2.0	2.0	2.2		0.00050	7.8
(IE1-)KPER 80 K4 Ex nA IIC T3	0.55	3.75	1400	IE1- 71.9	70.7	64.1	0.69	1.6	4.1	2.1	2.0	2.3		0.00087	10.6
(IE1-)KPER 80 G4 Ex nA IIC T3	0.75	5.12	1400	IE1- 73.6	72.2	66.8	0.70	2.1	4.6	2.2	2.1	2.3		0.00107	11.7
(IE1-)KPER 90 S4 Ex nA IIC T3	1.1	7.45	1410	IE1- 76.7	76.8	73.6	0.79	2.62	5.5	2.3	2.2	2.5		0.00207	15.5
(IE1-)KPER 90 L4 Ex nA IIC T3	1.5	10.2	1400	IE1- 78.6	79.1	76.9	0.81	3.4	5.5	2.5	2.4	2.6		0.00260	18.0
(IE1-)KPER 100 L4 Ex nA IIC T3	2.2	14.9	1410	IE1- 80.2	80.7	79.5	0.80	4.95	6.0	2.5	2.3	2.7		0.00400	23.5
(IE1-)KPER 100 LX4 Ex nA IIC T3	3.0	20	1430	IE1- 82.4	82.8	80.8	0.79	6.65	6.5	2.5	2.2	2.9		0.00725	30
(IE1-)KPER 112 M4 Ex nA IIC T3	4.0	26.6	1435	IE1- 84.1	85.1	83.6	0.78	8.8	6.9	2.6	2.5	3.2		0.009	37
(IE1-)KPER 112 MX4 Ex nA IIC T3	5.5	36.9	1425	IE1- 85.2	86.5	85.8	0.79	11.8	6.3	2.5	2.4	2.9		0.011	47
(IE1-)KPER 132 S4T Ex nA IIC T3	5.5	36.9	1425	IE1- 85.2	86.5	85.8	0.79	11.8	6.3	2.5	2.4	2.9		0.011	47
(IE1-)K11R 132 S4 Ex nA IIC T3	5.5	36	1440	IE1- 84.9	84.9	83.4	0.89	10.5	6.5	1.9	1.7	3.0	IBExU09ATEXB006	0.015	51
(IE1-)K11R 132 M4 Ex nA IIC T3	7.5	49	1450	IE1- 86.5	85.5	84.0	0.84	15	6.0	2.0	1.7	2.9	IBExU09ATEXB006	0.028	73
(IE1-)K11R 160 M4 Ex nA IIC T3	11.0	72	1450	IE1- 88.0	87.6	85.6	0.85	21	6.8	2.2	1.9	3.3	IBExU09ATEXB006	0.035	92
(IE1-)K11R 160 L4 Ex nA IIC T3	15.0	98	1465	IE1- 88.7	88.3	85.8	0.86	28.5	7.3	2.5	2.0	3.0	IBExU09ATEXB006	0.078	132
(IE1-)K11R 180 M4 Ex nA IIC T3	18.5	121	1460	IE1- 89.3	88.8	86.8	0.86	35	6.8	2.5	2.0	2.9	IBExU09ATEXB006	0.090	145
(IE1-)K11R 180 L4 Ex nA IIC T3	22	143	1465	IE1- 89.9	89.9	88.4	0.84	42	6.5	2.0	1.8	2.6	IBExU09ATEXB006	0.138	185
(IE1-)K11R 200 L4 Ex nA IIC T3	30	196	1465	IE1- 90.7	90.2	89.2	0.85	56	7.0	2.0	1.7	2.4	IBExU09ATEXB006	0.168	211
(IE1-)K11R 225 S4 Ex nA IIC T3	37	240	1470	IE1- 91.2	90.2	89.2	0.86	68	7.0	2.0	1.7	2.5	IBExU09ATEXB006	0.275	282
(IE1-)K11R 225 M4 Ex nA IIC T3	45	292	1470	IE1- 91.7	91.2	89.7	0.86	82.5	7.0	2.0	1.7	2.5	IBExU09ATEXB006	0.313	323
(IE1-)K11R 250 M4 Ex nA IIC T3	55	356	1475	IE1- 92.3	91.8	90.8	0.86	100	7.0	2.2	1.7	2.3	IBExU09ATEXB006	0.525	394
(IE1-)K11R 280 S4 Ex nA IIC T3	75	484	1480	IE1- 92.7	92.1	90.6	0.86	136	7.0	2.0	1.7	2.2	IBExU09ATEXB006	0.950	540
(IE1-)K11R 280 M4 Ex nA IIC T3	90	581	1480	IE1- 93.3	92.2	89.7	0.86	162	7.0	2.1	1.6	2.2	IBExU09ATEXB006	1.10	610
(IE1-)K11R 315 S4 Ex nA IIC T3	110	707	1485	IE1- 93.5	92.9	91.4	0.86	197	7.5	1.8	1.6	2.2	IBExU09ATEXB006	1.96	740
(IE1-)K11R 315 M4 Ex nA IIC T3	132	849	1485	IE1- 93.5	92.9	91.9	0.86	237	7.0	1.8	1.5	2.2	IBExU09ATEXB006	2.27	840
(IE1-)K11R 315 MX4 Ex nA IIC T3	160	1032	1480	IE1- 93.8	93.6	92.8	0.87	283	7.0	1.8	1.5	2.0	IBExU09ATEXB006	2.73	1000
(IE1-)K11R 315 MY4 Ex nA IIC T3	200	1286	1485	IE1- 94.3	93.3	92.8	0.88	348	7.5	2.0	1.8	2.4	IBExU09ATEXB006	4.82	1200
(IE1-)K11R 315 L4 Ex nA IIC T3	250	1608	1485	IE1- 94.3	93.2	92.7	0.90	425	8.0	2.0	1.6	2.3	IBExU09ATEXB006	5.93	1510
(IE1-)K11R 315 LX4 Ex nA IIC T3	315	2019	1490	IE1- 94.5	93.5	93.2	0.88	547	8.6	1.9	1.5	2.5	IBExU09ATEXB006	6.82	1630
(IE1-)K12R 355 MY4 Ex nA IIC T3	315	2016	1492	IE1- 94.0	93.9	92.4	0.85	569	7.1	1.4	1.0	2.9	IBExU09ATEXB006	5.60	1950
(IE1-)K12R 355 M4 Ex nA IIC T3	355	2275	1490	IE1- 94.5	94.2	93.2	0.84	646	8.1	1.8	1.0	3.1	IBExU09ATEXB006	7.9	2150
(IE1-)K12R 355 MX4 Ex nA IIC T3	400	2557	1494	IE1- 94.5	94.4	93.7	0.84	727	8.6	1.3	1.0	3.0	IBExU09ATEXB006	9.5	2400
(IE1-)K12R 355 L4 Ex nA IIC T3	450	2884	1490	IE1- 94.5	94.4	93.7	0.82	838	8.0	1.2	1.0	3.0	IBExU09ATEXB006	10.0	2500

Progressive series KPR/K10R possible upon request
Optionally in dust-protected version, protection type: Protection by enclosure "tc" to EN 60079-31, double marking on rating plate.
Other voltages and frequencies upon request. Changes are possible for motors which are not yet certified.

Three-phase motors with squirrel-cage rotor, Standard Efficiency IE1
Type of explosion protection „n“ (Increased safety „ec“)
for operation in Zone 2 according to EN 60079-15 (EN 60079-7)

II 3G Ex nA IIC T3 Gc

for rated voltage, temperature classes T1, T2 and T3
 with surface cooling, duty type S1, continuous duty
 thermal class F, degree of protection IP 55, 50 Hz

Motor selection data													Design point 400 V, 50 Hz		
Type	P kW	M _B Nm	n _B rpm	η _B (IEC/EN 60034-30-1)			cosφ _B -	I _B 400 V A	I _A /I _B -	M _A /M _B -	M _S /M _B -	M _K /M _B -	Certificate no. IBExU...	J kgm ²	m kg
				1.0	0.8	0.5									
Synchronous speed 1000 rpm – 6-pole version															
(IE1-)KPER 63 K6 Ex nA IIC T3	0.09	0.96	895	IE1- 50.4	46.2	38.4	0.56	0.46	2.5	2.0	2.0	2.4		0.00024	4.9
(IE1-)KPER 63 G6 Ex nA IIC T3	0.12	1.3	880	IE1- 52.4	50.1	43.2	0.56	0.59	2.5	2.0	2.0	2.3		0.00027	5.7
(IE1-)KPER 71 K6 Ex nA IIC T3	0.18	1.86	925	IE1- 57.9	53.9	45.4	0.51	0.88	2.8	1.6	1.6	2.1		0.00045	7.4
(IE1-)KPER 71 G6 Ex nA IIC T3	0.25	2.61	915	IE1- 59.6	57.5	49.5	0.55	1.1	2.9	2.0	2.0	2.2		0.00060	8.3
(IE1-)KPER 80 K6 Ex nA IIC T3	0.37	3.86	915	IE1- 66.3	64.5	57.1	0.66	1.22	3.4	2.0	2.0	2.0		0.00130	11.0
(IE1-)KPER 80 G6 Ex nA IIC T3	0.55	5.74	915	IE1- 68.5	67.0	60.7	0.67	1.73	3.7	2.2	2.2	2.4		0.00175	12.5
(IE1-)KPER 90 S6 Ex nA IIC T3	0.75	7.66	935	IE1- 70.5	68.8	63.2	0.64	2.4	4.5	2.4	2.4	2.6		0.00325	16.0
(IE1-)KPER 90 L6 Ex nA IIC T3	1.1	11.24	935	IE1- 73.4	73.0	68.4	0.68	3.18	4.6	2.2	2.2	2.6		0.00425	19.0
(IE1-)KPER 100 L6 Ex nA IIC T3	1.5	15.16	945	IE1- 76.0	75.2	71.1	0.73	3.9	4.6	2.1	2.0	2.4		0.00625	24.0
(IE1-)KPER 112 M6 Ex nA IIC T3	2.2	22.12	950	IE1- 78.1	78.8	75.8	0.76	5.35	5.3	2.2	2.1	2.7		0.01225	33.5
(IE1-)KPER 132 S6T Ex nA IIC T3	3.0	30.6	935	IE1- 81.9	82.8	81.4	0.75	7.05	5.2	2.5	2.5	2.9		0.0139	39.0
(IE1-)K11R 132 S6 Ex nA IIC T3	3.0	30	955	IE1- 79.7	79.7	76.2	0.82	6.6	5.7	1.8	1.6	2.7	IBExU09ATEXB006	0.0180	46
(IE1-)K11R 132 M6 Ex nA IIC T3	4.0	40	955	IE1- 81.4	80.4	75.4	0.80	8.9	6.0	2.2	2.0	3.1	IBExU09ATEXB006	0.0230	56
(IE1-)K11R 132 MX6 Ex nA IIC T3	5.5	55	955	IE1- 83.3	83.3	81.3	0.83	11.5	5.0	1.8	1.5	2.3	IBExU09ATEXB006	0.0430	72
(IE1-)K11R 160 M6 Ex nA IIC T3	7.5	75	960	IE1- 85.0	84.0	80.0	0.82	15.5	5.5	2.0	1.6	2.5	IBExU09ATEXB006	0.0530	91
(IE1-)K11R 160 L6 Ex nA IIC T3	11.0	109	965	IE1- 86.4	86.2	84.2	0.86	21.5	5.0	2.0	1.7	2.3	IBExU09ATEXB006	0.1130	122
(IE1-)K11R 180 L6 Ex nA IIC T3	15.0	148	965	IE1- 87.7	86.7	83.7	0.83	29.5	6.0	2.4	2.1	2.7	IBExU09ATEXB006	0.1450	142
(IE1-)K11R 200 L6 Ex nA IIC T3	18.5	182	970	IE1- 88.6	88.5	86.5	0.87	34.5	5.5	2.0	1.7	2.4	IBExU09ATEXB006	0.2280	190
(IE1-)K11R 200 LX6 Ex nA IIC T3	22	217	970	IE1- 89.2	88.9	86.4	0.87	41	6.2	2.2	1.8	2.6	IBExU09ATEXB006	0.2680	208
(IE1-)K11R 225 M6 Ex nA IIC T3	30	295	973	IE1- 90.2	89.8	87.8	0.89	54	6.5	2.2	1.7	2.5	IBExU09ATEXB006	0.4430	284
(IE1-)K11R 250 M6 Ex nA IIC T3	37	362	975	IE1- 90.8	90.6	87.8	0.89	66	6.5	2.2	1.7	2.3	IBExU09ATEXB006	0.8250	376
(IE1-)K11R 280 S6 Ex nA IIC T3	45	439	980	IE1- 91.4	91.4	89.4	0.87	81.5	6.0	2.0	1.5	2.0	IBExU09ATEXB006	1.28	465
(IE1-)K11R 280 M6 Ex nA IIC T3	55	536	980	IE1- 91.9	91.4	89.4	0.88	98	6.5	2.3	1.7	2.4	IBExU09ATEXB006	1.48	575
(IE1-)K11R 315 S6 Ex nA IIC T3	75	727	985	IE1- 92.7	92.0	91.0	0.87	134	7.0	2.0	1.6	2.4	IBExU09ATEXB006	2.63	690
(IE1-)K11R 315 M6 Ex nA IIC T3	90	868	990	IE1- 93.4	92.5	91.0	0.88	158	7.0	2.0	1.7	2.4	IBExU09ATEXB006	3.33	800
(IE1-)K11R 315 MX6 Ex nA IIC T3	110	1061	990	IE1- 93.3	93.1	91.6	0.88	193	7.5	2.2	1.7	2.6	IBExU09ATEXB006	3.60	880
(IE1-)K11R 315 MY6 Ex nA IIC T3	132	1273	990	IE1- 94.0	93.7	92.5	0.88	230	7.5	2.0	1.7	2.4	IBExU09ATEXB006	6.00	1050
(IE1-)K11R 315 L6 Ex nA IIC T3	160	1551	985	IE1- 94.3	94.0	92.8	0.89	275	7.5	2.3	1.9	2.4	IBExU09ATEXB006	6.67	1250
(IE1-)K11R 315 LX6 Ex nA IIC T3	180	1735	990	IE1- 94.0	94.1	95.3	0.86	321	8.5	2.5	1.6	2.6	IBExU09ATEXB006	8.6	1460
(IE1-)K12R 355 MY6 Ex nA IIC T3	200	1920	995	IE1- 94.4	94.3	93.8	0.83	368	7.0	1.5	1.3	2.4	IBExU09ATEXB006	8.1	1550
(IE1-)K12R 355 M6 Ex nA IIC T3	250	2402	994	IE1- 94.5	94.2	93.3	0.81	471	7.0	1.8	1.3	2.3	IBExU09ATEXB006	8.2	1850
(IE1-)K12R 355 MX6 Ex nA IIC T3	315	3023	995	IE1- 94.5	94.5	93.8	0.83	580	6.8	1.6	1.3	2.5	IBExU09ATEXB006	12.1	2200
(IE1-)K12R 355 LY6 Ex nA IIC T3	355	3407	995	IE1- 94.4	94.2	92.4	0.78	696	7.4	1.9	1.4	2.6	IBExU09ATEXB006	14.0	2400

Progressive series KPR/K10R possible upon request

Optionally in dust-protected version, protection type: Protection by enclosure "tc" to EN 60079-31, double marking on rating plate.

Other voltages and frequencies upon request. Changes are possible for motors which are not yet certified.

Three-phase motors with squirrel-cage rotor, Standard Efficiency IE1
Type of explosion protection „n“ (Increased safety „ec“)
for operation in Zone 2 according to EN 60079-15 (EN 60079-7)

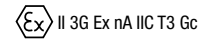

for rated voltage, temperature classes T1, T2 and T3
 with surface cooling, duty type S1, continuous duty
 thermal class F, degree of protection IP 55, 50 Hz

Motor selection data													Design point 400 V, 50 Hz			
Type	P kW	M _B Nm	n _B rpm	η _B (IEC/EN 60034-30-1)			cosφ _B -	I _B 400 V A	I _M /I _B -	M _M /M _B -	M _S /M _B -	M _K /M _B -	Certificate no. IBExU...	J	m	
				1.0	0.8	0.5								kgm ²	kg	
Synchronous speed 750 rpm – 8-pole version																
(IE1-)KPER 71 K8 Ex nA IIC T3	0.09	1.27	675	IE1-	45.5	42.1	34.8	0.51	0.56	2.1	1.9	1.9	2.1	0.00050	6.6	
(IE1-)KPER 71 G8 Ex nA IIC T3	0.12	1.71	670	IE1-	46.5	42.1	33.7	0.51	0.73	2.3	1.8	1.8	2.1	0.00060	8.1	
(IE1-)KPER 80 K8 Ex nA IIC T3	0.18	2.49	690	IE1-	56.5	53.4	45.0	0.59	0.78	2.8	2.0	2.0	2.2	0.00130	10.5	
(IE1-)KPER 80 G8 Ex nA IIC T3	0.25	3.44	695	IE1-	57.5	54.1	46.1	0.56	1.12	3.0	2.3	2.3	2.5	0.00175	12.0	
(IE1-)KPER 90 S8 Ex nA IIC T3	0.37	5.05	700	IE1-	61.8	59.7	52.8	0.54	1.60	3.0	1.9	1.9	2.1	0.00300	15.0	
(IE1-)KPER 90 L8 Ex nA IIC T3	0.55	7.56	695	IE1-	64.8	62.5	55.8	0.60	2.04	3.2	1.9	1.9	2.2	0.00375	18.0	
(IE1-)KPER 100 L8 Ex nA IIC T3	0.75	10.2	705	IE1-	66.8	64.7	57.9	0.60	2.70	3.3	1.8	1.8	2.2	0.00625	23.0	
(IE1-)KPER 100 LX8 Ex nA IIC T3	1.1	14.9	705	IE1-	72.9	73.3	69.6	0.67	3.25	4.0	2.0	2.0	2.4	0.00900	28.0	
(IE1-)KPER 112 M8 Ex nA IIC T3	1.5	20.3	705	IE1-	75.4	75.7	72.4	0.70	4.10	4.4	2.2	2.1	2.5	0.01225	33.5	
(IE1-)KPER 132 S8T Ex nA IIC T3	2.2	31	685	IE1-	74.1	74.8	72.4	0.68	6.30	3.8	2.0	1.9	2.3	0.01390	39.0	
(IE1-)K11R 132 S8 Ex nA IIC T3	2.2	30	705	IE1-	75.5	75.0	72.0	0.76	5.5	4.5	1.7	1.6	2.3	IBExU09ATEXB006	0.01800	46
(IE1-)K11R 132 M8 Ex nA IIC T3	3.0	41	705	IE1-	78.0	78.0	75.0	0.75	7.4	4.5	1.7	1.6	2.3	IBExU09ATEXB006	0.0230	53
(IE1-)K11R 160 M8 Ex nA IIC T3	4.0	54	710	IE1-	79.3	79.0	77.0	0.78	9.3	4.0	1.6	1.3	1.9	IBExU09ATEXB006	0.0430	70
(IE1-)K11R 160 MX8 Ex nA IIC T3	5.5	74	710	IE1-	81.4	81.0	78.0	0.78	12.5	4.5	1.7	1.6	2.1	IBExU09ATEXB006	0.0530	86
(IE1-)K11R 160 L8 Ex nA IIC T3	7.5	99	725	IE1-	83.0	83.0	79.0	0.78	16.5	4.5	1.8	1.6	2.1	IBExU09ATEXB006	0.1130	114
(IE1-)K11R 180 L8 Ex nA IIC T3	11.0	146	720	IE1-	85.0	84.0	81.5	0.78	24	4.5	2.0	1.7	2.1	IBExU09ATEXB006	0.1450	136
(IE1-)K11R 200 L8 Ex nA IIC T3	15.0	198	725	IE1-	86.5	86.0	83.0	0.79	31.5	5.0	2.0	1.7	2.3	IBExU09ATEXB006	0.228	175
(IE1-)K11R 225 S8 Ex nA IIC T3	18.5	244	725	IE1-	89.2	88.0	86.0	0.83	36	5.5	2.0	1.6	2.2	IBExU09ATEXB006	0.440	265
(IE1-)K11R 225 M8 Ex nA IIC T3	22	290	725	IE1-	89.2	89.0	88.5	0.84	42.5	5.0	1.8	1.5	2.2	IBExU09ATEXB006	0.440	265
(IE1-)K11R 250 M8 Ex nA IIC T3	30	393	730	IE1-	89.7	89.5	86.5	0.79	61	5.5	2.2	1.8	2.2	IBExU09ATEXB006	0.825	360
(IE1-)K11R 280 S8 Ex nA IIC T3	37	481	735	IE1-	90.5	90.0	87.5	0.80	74	5.5	2.0	1.5	2.0	IBExU09ATEXB006	1.35	465
(IE1-)K11R 280 M8 Ex nA IIC T3	45	585	735	IE1-	91.0	90.5	88.0	0.77	92.5	6.0	2.3	1.8	2.4	IBExU09ATEXB006	1.55	520
(IE1-)K11R 315 S8 Ex nA IIC T3	55	710	740	IE1-	92.1	91.0	89.5	0.80	108	6.5	1.8	1.6	2.3	IBExU09ATEXB006	2.63	690
(IE1-)K11R 315 M8 Ex nA IIC T3	75	968	740	IE1-	92.3	92.0	90.5	0.81	145	6.0	2.0	1.6	2.3	IBExU09ATEXB006	3.33	800
(IE1-)K11R 315 MX8 Ex nA IIC T3	90	1162	740	IE1-	92.5	92.0	90.5	0.81	173	6.0	1.9	1.6	2.2	IBExU09ATEXB006	3.60	880
(IE1-)K11R 315 MY8 Ex nA IIC T3	110	1420	740	IE1-	93.6	93.0	91.0	0.81	209	6.5	2.1	1.8	2.4	IBExU09ATEXB006	6.00	1100
(IE1-)K11R 315 L8 Ex nA IIC T3	132	1704	740	IE1-	94.0	93.3	91.0	0.83	244	6.3	2.0	1.7	2.1	IBExU09ATEXB006	6.76	1250
(IE1-)K11R 315 LX8 Ex nA IIC T3	160	2065	740	IE1-	94.2	93.5	91.0	0.79	310	7.2	2.2	1.9	2.5	IBExU09ATEXB006	8.71	1430
(IE1-)K12R 355 MY8 Ex nA IIC T3	160	2054	744	IE1-	93.5	93.3	92.5	0.80	309	6.8	1.3	1.0	2.5	IBExU09ATEXB006	9.3	1700
(IE1-)K12R 355 M8 Ex nA IIC T3	200	2571	743	IE1-	93.9	93.6	92.8	0.77	399	6.5	1.6	1.0	2.7	IBExU09ATEXB006	9.5	1850
(IE1-)K12R 355 MX8 Ex nA IIC T3	250	3209	744	IE1-	94.1	93.9	92.8	0.78	492	6.6	1.3	1.0	2.8	IBExU09ATEXB006	13.4	2200
(IE1-)K12R 355 LY8 Ex nA IIC T3	280	3594	744	IE1-	93.6	93.4	92.3	0.78	554	8.2	1.2	1.0	2.8	IBExU09ATEXB006	15.8	2400

Progressive series KPR/K10R possible upon request

Optionally in dust-protected version, protection type: Protection by enclosure "tc" to EN 60079-31, double marking on rating plate.

Other voltages and frequencies upon request. Changes are possible for motors which are not yet certified.

Three-phase motors with squirrel-cage rotor, Premium Efficiency IE3
Type of explosion protection – Protection by enclosure „tb“
for operation in Zone 21 according to EN 60079-31

Ex II 2D Ex tb III C T125 °C Db

for rated voltage, temperature classes T1, T2 and T3
 with surface cooling, duty type S1, continuous duty
 thermal class F, degree of protection IP 55, 50 Hz

Motor selection data											Design point 400 V, 50 Hz				
Type	P	M _B	n _B	η _B			cosφ _B	I _B	I _A /I _B	M _A /M _B	M _S /M _B	M _K /M _B	Certificate no. IExU...	J	m
	kW	Nm	rpm	100 %	75 %	50 %	-	A	-	-	-	-		kgm ²	kg
Synchronous speed 3000 rpm – 2-pole version															
IE3-KPER 63 G2 Ex II 2D	0.18	0.6	2750	IE3- 65.9	65.7	63.6	0.86	0.5	4.2	2.1	1.9	2.2	IBExU02ATEX1110/26	0.00015	5.2
IE3-KPR 63 KY2 Ex II 2D	0.25	0.7	2850	IE3- 69.7	67.7	61.6	0.78	0.7	5.2	2.5	2.5	2.9	IBExU02ATEX1110/23	0.00025	6.3
IE3-KPER 71 G2 Ex II 2D	0.37	1.2	2840	IE3- 73.8	72.7	69.3	0.82	0.9	6.0	2.7	2.7	3	IBExU02ATEX1111/09	0.00032	7.6
IE3-KPER 80 K2 Ex II 2D	0.55	1.8	2850	IE3- 77.8	76.8	76.0	0.82	1.2	6.5	3	3	2.7	IBExU02ATEX1112/01	0.00057	10.7
IE3-KPR 80 K2 Ex II 2D	0.75	2.5	2870	IE3- 80.7	81.7	81.2	0.88	1.6	6.8	2.6	2.9	2.5	IBExU02ATEX1112/51	0.00132	15
IE3-KPR 80 G2 Ex II 2D	1.1	3.7	2870	IE3- 82.7	83.7	82.8	0.89	2.3	7.3	3	3.2	2.7	IBExU02ATEX1112/50	0.0017	18
IE3-KPR 90 S2 Ex II 2D	1.3	4.3	2870	IE3- 83.5	84.5	84.5	0.91	2.6	6.1	1.8	2.5	1.7	IBExU02ATEX1113/41	0.00275	23.5
IE3-KPR 90 L2 Ex II 2D	1.85	6.1	2880	IE3- 85.1	86.1	85.6	0.92	3.6	7.2	2.3	3.1	2	IBExU02ATEX1113/45	0.00333	29
IE3-KPR 100 L2 Ex II 2D	2.5	8.2	2910	IE3- 86.4	87.1	84.9	0.89	4.9	6.8	1.7	2.7	1.6	IBExU02ATEX1114/36	0.0045	31
IE3-KPER 112 MX2 Ex II 2D	3.3	10.8	2910	IE3- 87.4	88.0	87.4	0.88	6.5	7.8	1.7	3.3	1.7	IBExU02ATEX1115/41	0.0055	38
IE3-W41R 112 M2 Ex II 2D	4	13.0	2930	IE3- 89.2	89.2	87.9	0.87	7.4	6.9	1.5	1.2	2.9		0.011	60
IE3-W41R 132 S2 Ex II 2D	5.5	18.0	2930	IE3- 89.2	88.6	87.0	0.84	10.5	7.7	1.9	1.3	3.5	IBExU04ATEX1118	0.011	65
IE3-W41R 132 SX2 Ex II 2D	7.5	24.0	2925	IE3- 90.1	89.4	87.9	0.87	14.0	8.0	2.5	2.1	3.3	IBExU04ATEX1118	0.0168	75
IE3-W41R 160 M2 Ex II 2D	11	36.0	2950	IE3- 91.4	91.7	90.5	0.90	19.5	8.0	2.2	1.8	3.2	IBExU04ATEX1118	0.0575	125
IE3-W41R 160 MX2 Ex II 2D	15	49.0	2950	IE3- 91.9	92.0	91.3	0.91	26.0	7.9	2.2	1.7	3.1	IBExU04ATEX1118	0.0675	145
IE3-W41R 160 L2 Ex II 2D	18.5	60.0	2960	IE3- 92.4	92.5	91.4	0.90	32.0	9.2	2.6	2.1	3.6	IBExU04ATEX1118	0.078	160
IE3-W41R 180 M2C Ex II 2D	22	71	2975	IE3- 92.7	92.6	91.5	0.91	37.5	8.9	1.9	1.4	3.3	IBExU04ATEX1118	0.1717	214
IE3-W41R 200 L2 Ex II 2D	30	97	2965	IE3- 93.3	92.2	90.6	0.88	52.5	8.6	2.1	1.6	3.3	IBExU04ATEX1118	0.36	305
IE3-W41R 200 LX2C Ex II 2D	37	119	2980	IE3- 93.7	92.9	91.7	0.89	64.0	8.7	1.7	1.3	3.2	IBExU04ATEX1118	0.4757	310
IE3-W41R 225 M2 Ex II 2D	45	145	2960	IE3- 94.0	93.7	93.0	0.89	77.5	8.8	2.3	1.9	3.2	IBExU04ATEX1118	0.375	375
IE3-W41R 250 M2 Ex II 2D	55	177	2970	IE3- 94.6	94.4	93.6	0.91	92	8.9	2.2	1.9	3.2	IBExU04ATEX1118	0.65	510
IE3-W41R 280 S2 Ex II 2D	75	241	2967	IE3- 94.7	94.5	93.9	0.89	128	8.1	1.9	1.9	2.8	IBExU04ATEX1118	0.65	500
IE3-W41R 280 M2 Ex II 2D	90	289	2970	IE3- 95.0	94.5	94.0	0.90	152	8.4	2.2		3.1	IBExU04ATEX1118	0.675	545
IE3-W41R 315 S2 Ex II 2D	110	354	2970	IE3- 95.2	94.5	93.5	0.89	187	10.0	1.9	1.7	3.0	IBExU04ATEX1118	1.21	750
IE3-W41R 315 M2 Ex II 2D	132	423	2980	IE3- 95.4	95.0	94.5	0.89	224	10.0	2.0	1.8	3.0	IBExU04ATEX1118	1.44	815
IE3-W41R 315 MX2 Ex II 2D	160	513	2980	IE3- 95.7	95.7	95.0	0.9	268	8.5	2.3	1.7	2.6	IBExU04ATEX1118	2.37	1095
IE3-W41R 315 MY2 Ex II 2D	200	641	2980	IE3- 95.8	95.9	95.5	0.91	331	8.3	2.6	1.6	2.4	IBExU04ATEX1118	2.82	1200
IE3-W41R 315 L2 Ex II 2D	250	800	2985	IE3- 96.0	96.0	95.9	0.92	409	8.4	2.5	1.4	2.3	IBExU04ATEX1118	3.66	1460
IE3-W41R 315 LX2 Ex II 2D	315	1008	2985	IE3- 95.8	95.8	95.8	0.92	516	8.5	2.8	1.6	2.5	IBExU04ATEX1118	4.43	1700
IE3-W41R 355 M2G Ex II 2D	355	1136	2985	IE3- 96.0	96.0	96.0	0.92	580	7.7	1.9	1.5	3.8	IBExU04ATEX1118	4.20	2000
IE3-W42R 355 MX2G Ex II 2D	400	1278	2990	IE3- 95.8	95.8	95.3	0.91	665	8.5	1.5	1.2	2.5		5.50	2200
IE3-W42R 355 L2G Ex II 2D	500	1597	2990	IE3- 95.8	95.8	95.3	0.90	840	9.0	2.0	1.3	3.0		7.10	2445
IE3-W42R 400 M2G Ex nA IIC T3	530	1690	2990	IE3- 95.8	95.4	95.0	0.84	950	8.5	1.7	1.1	2.2		8.44	3060
IE3-W42R 400 MX2G Ex nA IIC T3	570	1820	2990	IE3- 95.8	95.8	95.3	0.90	955	8.1	2.0	1.4	2.2		9.41	3200
IE3-W42R 400 L2G Ex nA IIC T3	650	2075	2990	IE3- 96.1	96.0	95.4	0.90	1085	8.1	2.2	1.2	2.4		10.41	3400

Other voltages and frequencies upon request. Changes are possible for motors which are not yet certified.

Three-phase motors with squirrel-cage rotor, Premium Efficiency IE3
Type of explosion protection – Protection by enclosure „tb“
for operation in Zone 21 according to EN 60079-31

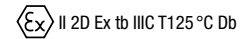

for rated voltage, temperature classes T1, T2 and T3
 with surface cooling, duty type S1, continuous duty
 thermal class F, degree of protection IP 55, 50 Hz

Motor selection data													Design point 400 V, 50 Hz		
Type	P kW	M _B Nm	n _B rpm	η _B (IEC/EN 60034-30-1)			cosφ _B -	I _B 400 V A	I _A /I _B -	M _A /M _B -	M _S /M _B -	M _K /M _B -	Certificate no. IBExU...	J	m
				100 %	75 %	50 %								kgm ²	kg
Synchronous speed 1500 rpm – 4-pole version															
IE3-KPER 63 G4 Ex II 2D	0.12	0.85	1355	IE3- 64.8	65.2	62.3	0.75	0.4	3.3	1.9	1.9	2.1	IBExU02ATEX1110/14	0.00024	5.2
IE3-KPR 63 G4 Ex II 2D	0.18	1.22	1405	IE3- 69.9	68.0	62.2	0.70	0.6	4.1	2.1	2.1	2.6	IBExU02ATEX1110/29	0.0005	7.1
IE3-KPR 71 G4 Ex II 2D	0.37	2.45	1440	IE3- 77.3	77.6	75.0	0.69	1.0	5.8	2.9	2.9	3.3	IBExU02ATEX1111/39	0.0005	7.8
IE3-KPR 80 GX4 Ex II 2D	0.75	4.96	1445	IE3- 82.5	81.9	79.0	0.74	1.8	7.3	3.4	4.2	3.4	IBExU02ATEX1112/59	0.0028	17.5
IE3-KPR 90 S4 Ex II 2D	1	6.59	1450	IE3- 83.7	83.3	80.6	0.80	2.3	7.8	3.3	4.0	3.1	IBExU02ATEX1113/46	0.0045	28
IE3-KPR 90 LX4 Ex II 2D	1.35	8.98	1435	IE3- 84.9	85.0	83.4	0.84	2.9	7.2	3.3	3.6	2.8	IBExU02ATEX1113/47	0.0058	31
IE3-KPR 100 L4 Ex II 2D	2	13.22	1445	IE3- 86.3	86.7	85.4	0.81	4.3	7.5	3.3	3.8	3.0	IBExU02ATEX1114/45	0.011	45
IE3-KPR 100 LZ4 Ex II 2D	2.5	16.52	1445	IE3- 87.1	87.6	86.4	0.83	5.2	7.6	2.9	3.7	2.7	IBExU02ATEX1114/44	0.013	50
IE3-W41R 112 M4 Ex II 2D	4	26	1470	IE3- 89.9	89.8	88.4	0.83	7.7	9.5	2.8	2.4	4.5		0.02	65
IE3-W41R 132 S4 Ex II 2D	5.5	35	1480	IE3- 91.0	90.2	87.8	0.73	12.0	9.9	3.4	2.8	5.4	IBExU04ATEX1118	0.035	90
IE3-W41R 132 M4 Ex II 2D	7.5	49	1475	IE3- 91.3	91.3	90.1	0.83	14.5	8.6	2.4	2.0	3.9	IBExU04ATEX1118	0.043	100
IE3-W41R 160 M4 Ex II 2D	11	71	1475	IE3- 91.4	91.5	90.5	0.83	21.0	7.5	2.5	2.0	3.2	IBExU04ATEX1118	0.078	125
IE3-W41R 160 L4C Ex II 2D	15	96	1490	IE3- 92.8	92.5	91.0	0.83	28.0	10.5	2.8	2.4	3.9	IBExU04ATEX1118	0.1567	175
IE3-W41R 180 M4 Ex II 2D	18.5	120	1475	IE3- 92.7	92.9	92.0	0.84	34.5	6.9	1.9	1.7	3.0	IBExU04ATEX1118	0.168	210
IE3-W41R 180 L4 Ex II 2D	22	142	1480	IE3- 93.0	93.0	92.1	0.84	40.5	7.6	2.2	2.0	3.2	IBExU04ATEX1118	0.203	240
IE3-W41R 200 L4C Ex II 2D	30	193	1485	IE3- 93.6	92.4	92.4	0.85	54.5	7.0	1.6	1.4	2.6	IBExU04ATEX1118	0.411	327
IE3-W41R 225 S4C Ex II 2D	37	237	1490	IE3- 93.9	93.8	93.2	0.85	67.0	7.4	1.9	1.4	2.7	IBExU04ATEX1118	0.4675	367
IE3-W41R 225 M4 Ex II 2D	45	290	1482	IE3- 94.2	94.3	94.0	0.82	84	8.1	2.6	2.1	2.6	IBExU04ATEX1118	0.619	450
IE3-W41R 250 M4 Ex II 2D	55	354	1485	IE3- 94.7	94.8	94.4	0.83	101	8.1	2.1	1.8	2.5	IBExU04ATEX1118	0.95	550
IE3-W41R 280 S4 Ex II 2D	75	482	1485	IE3- 95.0	94.6	94.2	0.83	137	8.2	2.1	1.8	2.5	IBExU04ATEX1118	1.1	617
IE3-W41R 280 M4 Ex II 2D	90	578	1487	IE3- 95.2	94.7	94.0	0.83	164	9.2	2.1	1.9	2.7	IBExU04ATEX1118	1.96	785
IE3-W41R 315 S4 Ex II 2D	110	706	1487	IE3- 95.4	95.0	94.3	0.82	203	9.5	1.9	1.7	2.7	IBExU04ATEX1118	1.96	760
IE3-W41R 315 M4 Ex II 2D	132	849	1485	IE3- 95.6	95.4	95.0	0.83	240	9.0	2.2	1.9	2.7	IBExU04ATEX1118	2.27	850
IE3-W41R 315 MX4 Ex II 2D	160	1026	1490	IE3- 95.8	95.8	95.0	0.84	287	9.5	2.1	2.0	3.2	IBExU04ATEX1118	4.01	1120
IE3-W41R 315 MY4 Ex II 2D	200	1282	1490	IE3- 96.0	95.8	95.5	0.87	346	9.5	2.1	1.7	2.7	IBExU04ATEX1118	4.82	1250
IE3-W41R 315 L4 Ex II 2D	250	1602	1490	IE3- 96.2	96.2	96.0	0.87	431	9.4	2.2	1.8	2.7	IBExU04ATEX1118	5.93	1450
IE3-W41R 315 LX4 Ex II 2D	315	2019	1490	IE3- 96.0	96.0	96.0	0.87	544	9.5	2.3	1.7	2.9	IBExU04ATEX1118	6.82	1630
IE3-W41R 355 M4 Ex II 2D	355	2271	1493	IE3- 96.2	96.2	95.5	0.87	612	8.1	1.3	1.0	2.7	IBExU04ATEX1118	7.90	2150
IE3-W42R 355 MX4 Ex II 2D	400	2557	1494	IE3- 96.0	96.0	95.5	0.84	719	8.0	1.7	1.4	2.4		9.50	2400
IE3-W42R 355 L4 Ex II 2D	500	3205	1490	IE3- 96.0	96.0	95.5	0.84	899	7.2	1.6	1.2	2.2		10.00	2500
IE3-W42R 400 M4 Ex II 2D	560	3582	1493	IE3- 96.0	96.0	95.5	0.84	1006	9.0	3.4	2.9	3.9		12.60	2900
IE3-W42R 400 MX4 Ex II 2D	630	4030	1493	IE3- 96.0	96.0	95.5	0.85	1119	9.0	3.6	3.0	4.2		14.33	3100
IE3-W42R 400 L4 Ex II 2D	710	4542	1493	IE3- 96.0	96.0	95.5	0.85	1261	9.0	3.9	3.1	4.2		16.29	3450

Other voltages and frequencies upon request. Changes are possible for motors which are not yet certified.

Three-phase motors with squirrel-cage rotor, Premium Efficiency IE3 Type of explosion protection – Protection by enclosure „tb“ for operation in Zone 21 according to EN 60079-31

II 2D Ex tb III C T125 °C Db

for rated voltage, temperature classes T1, T2 and T3
with surface cooling, duty type S1, continuous duty
thermal class F, degree of protection IP 55, 50 Hz

Motor selection data	P	M _B	n _B	η _B			cosφ _B	I _B	I _A /I _B	M _A /M _B	M _S /M _B	M _K /M _B	Certificate no. IBExU...	Design point 400 V, 50 Hz	
				(IEC/EN 60034-30-1)										J	m
				100 %	75 %	50 %									
Synchronous speed 1000 rpm – 6-pole version															
IE3-KPR 80 G6 Ex II 2D	0.55	5.6	945	IE3- 77.2	77.5	75.0	0.70	1.5	4.2	2.2	2.4	2.2	IBExU02ATEX1112/53	0.00425	18
IE3-KPR 90 L6 Ex II 2D	0.95	9.5	960	IE3- 80.2	78.6	74.7	0.67	2.7	5.6	3.1	3.5	2.8	IBExU02ATEX1113/42	0.0072	30
IE3-KPR 100 LX6 Ex II 2D	1.3	12.9	960	IE3- 81.8	81.5	78.6	0.72	3.2	6.0	2.4	3.2	2.4	IBExU02ATEX1114/39	0.0139	36
IE3-KPER 112 MV6 Ex II 2D	1.9	18.8	965	IE3- 83.6	82.6	78.9	0.67	5.1	6.8	3.6	4.3	3.6	IBExU02ATEX1115/28	0.0155	48
IE3-W41R 132 S6 Ex II 2D	3	30.0	965	IE3- 86.3	86.7	85.6	0.82	6.1	6.2	2.0	1.3	3.1	IBExU04ATEX1118	0.029	70
IE3-W41R 132 M6 Ex II 2D	4	40.0	965	IE3- 86.8	87.0	86.0	0.80	8.3	4.8	1.7	1.4	2.4	IBExU04ATEX1118	0.043	75
IE3-W41R 132 MX6 Ex II 2D	5.5	54.0	970	IE3- 88.6	88.6	87.2	0.80	11.0	6.0	2.1	1.7	3.0	IBExU04ATEX1118	0.053	105
IE3-W41R 160 M6 Ex II 2D	7.5	73.0	980	IE3- 90.2	90.0	88.3	0.83	14.5	6.4	2.4	2.0	3.0	IBExU04ATEX1118	0.145	145
IE3-W41R 160 L6C Ex II 2D	11	107.0	985	IE3- 91.4	91.2	89.8	0.85	20.5	6.8	2.2	2	2.8	IBExU04ATEX1118	0.166	168
IE3-W41R 180 L6C Ex II 2D	15	145.0	985	IE3- 91.2	91.3	90.2	0.87	27.5	6.8	2	1.7	2.7	IBExU04ATEX1118	0.3396	214
IE3-W41R 200 L6 Ex II 2D	18.5	180.0	980	IE3- 91.8	91.7	90.5	0.87	33.5	7.2	2.3	2	3	IBExU04ATEX1118	0.514	310
IE3-W41R 200 LX6C Ex II 2D	22	213.0	985	IE3- 92.2	91.5	90.0	0.87	39.5	7.6	2.1	1.7	2.9	IBExU04ATEX1118	0.6476	321
IE3-W41R 225 M6 Ex II 2D	30	291	984	IE3- 92.9	92.2	91.0	0.84	55.5	7.2	2.7	2.2	2.9	IBExU04ATEX1118	0.92	400
IE3-W41R 250 M6 Ex II 2D	37	359	985	IE3- 93.3	93.2	92.3	0.86	66.5	7.1	2.8	2.0	2.7	IBExU04ATEX1118	1.48	545
IE3-W41R 280 S6 Ex II 2D	45	434	990	IE3- 93.7	93.5	91.5	0.86	80.5	8.5	2.1	1.8	2.8	IBExU04ATEX1118	2.63	695
IE3-W41R 280 M6 Ex II 2D	55	531	990	IE3- 94.2	94.1	93.1	0.85	99	9.0	2.2	1.9	3.1	IBExU04ATEX1118	3.33	815
IE3-W41R 315 S6 Ex II 2D	75	723	990	IE3- 94.6	94.0	93.5	0.86	133	8.2	1.8	1.4	2.3	IBExU04ATEX1118	5.55	1060
IE3-W41R 315 M6 Ex II 2D	90	868	990	IE3- 94.9	94.0	93.0	0.83	165	8.5	2.2	1.7	2.8	IBExU04ATEX1118	6	1100
IE3-W41R 315 MX6 Ex II 2D	110	1.061	990	IE3- 95.1	95.0	94.5	0.86	194	8.5	2.5	1.7	2.7	IBExU04ATEX1118	6.67	1210
IE3-W41R 315 L6 Ex II 2D	132	1.267	995	IE3- 95.4	95.0	94.5	0.87	230	9.0	2.8	2.0	3.2	IBExU04ATEX1118	8.6	1550
IE3-W41R 355 M6 Ex II 2D	160	1.536	995	IE3- 95.6	95.0	94.6	0.82	295	8.0	2.1	0.0	2.7	IBExU04ATEX1118	8.2	1850
IE3-W42R 355 MX6 Ex II 2D	200	1919	995	IE3- 95.8	95.2	95.0	0.83	363	8.0	1.8	1.3	2.5		12.10	2200
IE3-W42R 355 L6 Ex II 2D	250	2402	994	IE3- 95.8	95.5	95.0	0.81	468	7.0	1.8	1.3	2.3		14.00	2400
IE3-W42R 355 LX6 Ex II 2D	315	3032	992	IE3- 95.8	95.5	95.3	0.86	554	7.4	2.5	2.0	2.7		14.00	2400
IE3-W42R 400 MY6 Ex II 2D	355	3407	995	IE3- 95.8	95.5	94.5	0.85	632	8.0	2.0	1.6	2.6		16.54	2900
IE3-W42R 400 M6 Ex II 2D	400	3847	993	IE3- 95.8	95.5	94.5	0.87	696	7.0	1.8	1.5	2.3		16.54	2900
IE3-W42R 400 MX6 Ex II 2D	450	4327	993	IE3- 95.8	95.7	94.6	0.83	821	7.3	1.8	1.5	2.1		18.44	3100
IE3-W42R 400 L6 Ex II 2D	500	4808	993	IE3- 95.8	95.6	94.5	0.83	911	7.5	1.9	1.7	2.2		20.63	3200

Other voltages and frequencies upon request. Changes are possible for motors which are not yet certified.

Three-phase motors with squirrel-cage rotor, Premium Efficiency IE3
Type of explosion protection – Protection by enclosure „tb“
for operation in Zone 21 according to EN 60079-31

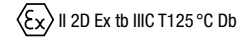

for rated voltage, temperature classes T1, T2 and T3
 with surface cooling, duty type S1, continuous duty
 thermal class F, degree of protection IP 55, 50 Hz

Motor selection data													Design point 400 V, 50 Hz		
Type	P kW	M _B Nm	n _B rpm	η _B (IEC/EN 60034-30-1)			cosφ _B -	I _B 400 V A	I _A /I _B -	M _A /M _B -	M _S /M _B -	M _K /M _B -	Certificate no. IBExU...	J	m
				100 %	75 %	50 %								kgm ²	kg
Synchronous speed 750 rpm – 8-pole version															
IE3-W41R 132 S8 Ex II 2D	2.2	29	725	IE3- 84.4	84.5	82.4	0.7	5.4	4.1	1.6	1.5	2.3	IBExU04ATEX1118	0.043	80
IE3-W41R 132 M8 Ex II 2D	3	40	720	IE3- 83.5	83.5	81.4	0.72	7	3.9	1.6	1.4	2.1	IBExU04ATEX1118	0.043	74
IE3-W41R 160 M8 Ex II 2D	4	52	735	IE3- 87	86.7	83.8	0.71	9.4	5.4	2.5	2.2	2.9	IBExU04ATEX1118	0.113	119
IE3-W41R 160 MX8 Ex II 2D	5.5	72	730	IE3- 87.5	87.5	85.6	0.73	12.5	4.7	1.9	1.7	2.5	IBExU04ATEX1118	0.145	143
IE3-W41R 160 L8 Ex II 2D	7.5	98	733	IE3- 87.9	87.6	85.6	0.73	17	5.1	2.1	1.8	2.7	IBExU04ATEX1118	0.166	155
IE3-W41R 180 L8 Ex II 2D	11	145	725	IE3- 89.3	89	87.1	0.75	23.5	5.4	2.1	1.9	2.8	IBExU04ATEX1118	0.228	175
IE3-W41R 200 L8 Ex II 2D	15	196	730	IE3- 89.6	90	89	0.80	30	5.3	1.8	1.7	2.5	IBExU04ATEX1118	0.324	235
IE3-W41R 225 S8 Ex II 2D	18.5	240	735	IE3- 90.1									IBExU04ATEX1118	0.514	310
IE3-W41R 225 M8 Ex II 2D	22	286	735	IE3- 91.5	91.6	90.6	0.79	44	5.7	2.3	2	2.5	IBExU04ATEX1118	0.825	360
IE3-W41R 250 M8 Ex II 2D	30	391	732	IE3- 91.3	91.9	91.4	0.81	58.5	5.4	2	1.8	2.3	IBExU04ATEX1118	0.92	420
IE3-W41R 280 S8 Ex II 2D	37	479	738	IE3- 92	92	90.8	0.78	74.5	5.9	2.3	1.8	2.4	IBExU04ATEX1118	1.55	555
IE3-W41R 280 M8 Ex II 2D	45	581	740	IE3- 93	93	92.4	0.78	89.5	6.5	1.7	1.5	2.4	IBExU04ATEX1118	2.63	700
IE3-W41R 315 S8 Ex II 2D	55	707	743	IE3- 93.3	93.3	92.4	0.78	109	7.0	1.9	1.7	2.5	IBExU04ATEX1118	3.33	805
IE3-W41R 315 M8 Ex II 2D	75	965	742	IE3- 93.8	94.2	93.8	0.81	142	7.0	1.9	1.7	2.3	IBExU04ATEX1118	5.55	1120
IE3-W41R 315 MX8 Ex II 2D	90	1157	743	IE3- 94.3	94.4	93.6	0.8	172	7.9	2.4	2.0	2.7	IBExU04ATEX1118	6	1185
IE3-W41R 315 MY8 Ex II 2D	110	1419	740	IE3- 93.8	94.0	93.8	0.82	206	6.5	1.9	1.5	2.1	IBExU04ATEX1118	6.76	1250
IE3-W41R 315 L8 Ex II 2D	132	1703	740	IE3- 94.2	94.2	93.5	0.8	253	8.0	2.4	1.9	2.7	IBExU04ATEX1118	8.71	1450
IE3-W41R 355 MY8 Ex II 2D	160	2051	745	IE3- 94.3	94.3	94.0	0.82	299	6.6	1.2	1.0	2.6	IBExU04ATEX1118	9.3	1700
IE3-W41R 355 M8 Ex II 2D	200	2564	745	IE3- 94.7	94.9	94.2	0.81	376	7.0	1.0	1.0	2.7	IBExU04ATEX1118	9.5	1890
IE3-W41R 355 MX8 Ex II 2D	230	2948	745	IE3- 95.2	95.2	95.0	0.83	420	7.0	1.2	1.0	2.6	IBExU04ATEX1118	13.40	2200
IE3-W41R 355 L8 Ex II 2D	250	3205	745	IE3- 94.8	94.1	91.5	0.78	488					IBExU04ATEX1118	15.80	2400
IE3-W42R 355 MX8 Ex II 2D	160	2054	744	IE3- 95.4	95.0	94.0	0.8	303	6.8	1.3	1.0	2.5		13.4	2200
IE3-W42R 355 L8 Ex II 2D	200	2570	743	IE3- 95.6	95.5	94.0	0.77	393	6.5	1.6	1.0	2.7		15.8	2400
IE3-W42R 355 LX8 Ex II 2D	250	3213	743	IE3- 95.6	95.4	93.8	0.78	487	6.4	2.5	1.9	2.5		15.8	2400
IE3-W42R 400 MY8 Ex II 2D	315	4048	743	IE3- 95.6	95.5	94.5	0.78	611	6.4	2.5	1.9	2.5		17.94	3000
IE3-W42R 400 M8 Ex II 2D	355	4550	745	IE3- 95.6	95.5	94.5	0.76	708	6.6	1.9	1.7	2.3		17.94	3000
IE3-W42R 400 MX8 Ex II 2D	400	5134	744	IE3- 95.6	95.6	94.6	0.73	831	6.1	1.8	1.7	1.9		19.99	3150
IE3-W42R 400 L8 Ex II 2D	450	5776	744	IE3- 95.6	95.6	94.6	0.72	947	6.4	2.0	1.7	2.0		22.34	3300

Other voltages and frequencies upon request. Changes are possible for motors which are not yet certified.

Three-phase motors with squirrel-cage rotor, High Efficiency IE2 Type of explosion protection – Protection by enclosure „tb“ for operation in Zone 21 according to EN 60079-31

Ex II 2D Ex tb III C T125 °C Db

for rated voltage, temperature classes T1, T2 and T3
with surface cooling, duty type S1, continuous duty
thermal class F, degree of protection IP 55, 50 Hz

Motor selection data													Design point 400 V, 50 Hz		
Type	P	M _B	n _B	η _B			cosφ _B	I _B	I _A /I _B	M _A /M _B	M _S /M _B	M _K /M _B	Certificate no. IBExU...	J	m
	kW	Nm	rpm	100 %	75 %	50 %	-	A	-	-	-	-	IBExU...	kgm ²	kg
Synchronous speed 3000 rpm – 2-pole version															
IE2-KPR 80 K2 Ex II 2D	0.75	2.49	2880	IE2- 77.4	83.6	81.6	0.88	1.48	7.7	2.2	2.1	2.7	DMT 00 ATEX E 012 X	0.00132	15
IE2-KPR 80 G2 Ex II 2D	1.1	3.64	2885	IE2- 79.6	82.1	81.2	0.89	2.15	7.8	2.5	2.3	2.8	DMT 00 ATEX E 012 X	0.0017	18
IE2-KPR 90 S2 Ex II 2D	1.5	4.92	2910	IE2- 81.3	85.5	82.9	0.87	2.9	9.0	2.8	2.4	3.4	DMT 00 ATEX E 012 X	0.00275	23.5
IE2-KPR 90 L2 Ex II 2D	2.2	7.29	2880	IE2- 83.2	85.7	83.9	0.88	4.25	8.0	2.5	2.3	2.9	DMT 00 ATEX E 012 X	0.00275	23.5
IE2-KPR 100 L2 Ex II 2D	3	9.78	2930	IE2- 84.6	86.2	83.5	0.76	6.55	8.5	2.6	2.4	3.8	DMT 00 ATEX E 012 X	0.0045	31
IE2-KPER 112 M2 Ex II 2D	4	13.2	2900	IE2- 85.8	86.3	***)	0.81	8.4	7.0	2.2	2.1	2.9	DMT 00 ATEX E 012 X	0.0045	32
IE2-KPER 112 MX2 Ex II 2D	4	13.08	2920	IE2- 85.8	86.4	85.8	0.84	7.9	8.3	2.3	2.1	3.3	DMT 00 ATEX E 012 X	0.0055	38
IE2-KPER 112 ML2 Ex II 2D	5.5	18.2	2890	IE2- 85.9	86.6	***)	0.84	11	7.5	2.4	2.2	3.0	DMT 00 ATEX E 012 X	0.0055	38
IE2-KPER 112 MV2 Ex II 2D	5.5	18.11	2900	IE2- 87.0	88.7	88.8	0.88	10.3	7.8	2.0	1.9	2.7	DMT 00 ATEX E 012 X	0.0068	46
IE2-KPER 132 SY2T Ex II 2D	5.5	18.2	2890	IE2- 87.0	86.6	***)	0.84	11	7.5	2.4	2.2	3.0	DMT 00 ATEX E 012 X	0.0055	40
IE2-KPER 132 S2T Ex II 2D	5.5	18.11	2900	IE2- 87.0	88.7	88.8	0.88	10.3	7.8	2.0	1.9	2.7	DMT 00 ATEX E 012 X	0.0068	48
IE2-KPER 112 MW2 Ex II 2D	7.5	24.9	2880	IE2- 88.1	88.0	***)	0.84	14.8	6.3	1.5	1.2	2.6	DMT 00 ATEX E 012 X	0.0068	46
IE2-KPER 132 SX2T Ex II 2D	7.5	24.9	2880	IE2- 88.1	88.0	***)	0.84	14.8	6.3	1.5	1.2	2.6	DMT 00 ATEX E 012 X	0.0068	48
IE2-WE1R 132 S2 Ex II 2D	5.5	18.0	2915	IE2- 88.7	88.7	87.8	0.85	10.5	6.8	1.9	1.5	3.0	IBExU04ATEX1118	0.0110	57
IE2-WE1R 132 SX2 Ex II 2D	7.5	24.5	2925	IE2- 88.8	89.2	88.3	0.91	13.5	6.7	2.1	1.6	2.9	IBExU04ATEX1118	0.0168	75
IE2-WE1R 160 M2 Ex II 2D	11.0	35.6	2950	IE2- 90.3	90.3	89.1	0.90	19.5	7.7	2.3	1.7	3.1	IBExU04ATEX1118	0.0258	125
IE2-WE1R 160 MX2 Ex II 2D	15.0	48.7	2940	IE2- 90.7	90.5	89.1	0.92	26	6.7	1.8	1.4	2.6	IBExU04ATEX1118	0.0675	140
IE2-WE1R 160 L2 Ex II 2D	18.5	60.2	2935	IE2- 91.0	91.4	91.4	0.91	32	7.2	2.0	1.5	2.8	IBExU04ATEX1118	0.0675	140
IE2-WE1R 180 M2 Ex II 2D	22	72	2935	IE2- 91.3	90.6	86.4	0.90	38.5	6.2	1.4	1.1	2.4	IBExU04ATEX1118	0.105	173
IE2-WE1R 200 L2 Ex II 2D	30	97	2945	IE2- 92.0	91.3	90.5	0.91	52	6.9	1.7	1.3	2.6	IBExU04ATEX1118	0.128	210
IE2-WE1R 200 LX2 Ex II 2D	37	120	2940	IE2- 92.5	92.3	91.6	0.92	63	7.4	1.9	1.4	2.9	IBExU04ATEX1118	0.154	233
IE2-WE2R 200 LX2 Ex II 2D	37	120	2940	IE2- 92.5	92.3	91.6	0.92	63	7.4	1.9	1.4	2.9	IBExU04ATEX1118	0.154	233
IE2-WE1R 225 M2 Ex II 2D	45	146	2950	IE2- 92.9	92.2	91.2	0.87	80.5	6.9	1.7	1.1	2.7	IBExU04ATEX1118	0.220	295
IE2-WE1R 250 M2 Ex II 2D	55	178	2955	IE2- 93.5	93.7	93.2	0.89	95.5	8.2	2.3	1.9	2.8	IBExU04ATEX1118	0.375	385
IE2-WE1R 280 S2 Ex II 2D	75	241	2970	IE2- 94.1	94.0	91.5	0.90	128	7.9	2.1	1.7	3.0	IBExU04ATEX1118	0.65	500
IE2-WE1R 280 M2 Ex II 2D	90	289	2970	IE2- 94.4	94.1	91.9	0.91	151	7.7	2.0	1.7	2.8	IBExU04ATEX1118	0.68	550
IE2-W21R 315 S2 Ex II 2D	110	353	2975	IE2- 94.5	94.3	93.3	0.89	189	8.0	1.3	1.2	2.4	IBExU04ATEX1118	1.21	730
IE2-W21R 315 M2 Ex II 2D	132	424	2975	IE2- 95.0	94.8	94.5	0.89	225	9.2	1.4	1.2	2.4	IBExU04ATEX1118	1.44	820
IE2-W21R 315 MX2 Ex II 2D	160	514	2973	IE2- 94.8	94.8	94.8	0.89	274	8.2	1.3	1.3	2.4	IBExU04ATEX1118	1.76	955
IE2-W21R 315 MY2 Ex II 2D	200	640	2983	IE2- 95.4	95.0	94.3	0.88	344	9.4	2.8	2.0	3.0	IBExU04ATEX1118	2.82	1200
IE2-W21R 315 L2 Ex II 2D	250	800	2984	IE2- 95.4	95.4	95.4	0.92	411	9.0	2.3	1.2	2.3	IBExU04ATEX1118	3.66	1450
IE2-W21R 315 LX2 Ex II 2D	315	1008	2985	IE2- 95.4	95.4	95.0	0.92	518	8.5	2.8	1.6	2.5	IBExU04ATEX1118	4.43	1700
IE2-W22R 355 M2G Ex II 2D	355	1136	2985	IE2- 95.5	95.5	95.5	0.92	583	7.7	1.3	1.0	2.6	IBExU04ATEX1118	4.20	2000
IE2-W22R 355 MX2G Ex II 2D	400	1278	2990	IE2- 95.5	95.5	95.5	0.91	664	9.4	1.8	1.0	3.0	IBExU04ATEX1118	4.50	2200
W22R 355 LY2G Ex II 2D	450	1440	2985	IE2- 95.5	95.5	95.5	0.92	739	7.0	1.3	0.9	2.4	IBExU04ATEX1118	7.10	2400
W22R 355 L2G Ex II 2D	500	1597	2990	IE2- 95.5	95.5	95.5	0.92	821	8.5	1.5	1.2	2.5	IBExU04ATEX1118	7.10	2400

Other voltages and frequencies upon request. Changes are possible for motors which are not yet certified.

***) upon request

Three-phase motors with squirrel-cage rotor, High Efficiency IE2
Type of explosion protection – Protection by enclosure „tb“
for operation in Zone 21 according to EN 60079-31

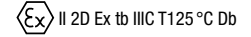

for rated voltage, temperature classes T1, T2 and T3
 with surface cooling, duty type S1, continuous duty
 thermal class F, degree of protection IP 55, 50 Hz

Motor selection data													Design point 400 V, 50 Hz		
Type	P kW	M _B Nm	n _B rpm	η _B (IEC/EN 60034-30-1)			cosφ _B -	I _B 400 V A	I _A /I _B -	M _A /M _B -	M _S /M _B -	M _K /M _B -	Certificate no. IBExU...	J kgm ²	m kg
				100 %	75 %	50 %									
Synchronous speed 1500 rpm – 4-pole version															
IE2-KPR 80 GY4 Ex II 2D	0.75	5.01	1430	IE2- 79.6	78.0	74.7	0.8	1.73	5.7	2.2	2.2	3.1	DMT 00 ATEX E 012 X	0.00207	14.5
IE2-KPR 80 G4 Ex II 2D	0.75	5.01	1430	IE2- 79.6	81.4	79.6	0.81	1.65	7.0	2.9	2.8	3.2	DMT 00 ATEX E 012 X	0.0026	17
IE2-KPR 90 S4 Ex II 2D	1.1	7.32	1435	IE2- 81.4	82.3	80.4	0.8	2.42	6.8	2.4	2.2	2.9	DMT 00 ATEX E 012 X	0.004	23
IE2-KPR 90 LW4 Ex II 2D	1.5	9.95	1440	IE2- 82.8	83.8	81.4	0.76	3.4	6.5	2.7	2.7	3.6	DMT 00 ATEX E 012 X	0.004	23
IE2-KPR 90 L4 Ex II 2D	1.5	9.91	1445	IE2- 82.8	83.2	80.7	0.77	3.35	7.2	3.2	3.0	3.5	DMT 00 ATEX E 012 X	0.0045	28
IE2-KPR 100 S4 Ex II 2D	2.2	14.5	1445	IE2- 84.3	84.9	82.7	0.79	4.67	7.3	2.7	2.5	3.1	DMT 00 ATEX E 012 X	0.00725	30
IE2-KPR 100 L4 Ex II 2D	2.2	14.4	1455	IE2- 84.3	85.2	81.7	0.77	4.8	9.3	3.2	3.0	3.6	DMT 00 ATEX E 012 X	0.009	36
IE2-KPR 100 LW4 Ex II 2D	3	19.8	1445	IE2- 85.5	85.8	83.6	0.79	6.33	7.8	3.0	2.9	3.6	DMT 00 ATEX E 012 X	0.009	36
IE2-KPR 100 LX4 Ex II 2D	3	19.7	1455	IE2- 85.5	86.3	84.5	0.77	6.5	9.0	3.3	3.1	3.9	DMT 00 ATEX E 012 X	0.011	45
IE2-KPER 112 MZ4 Ex II 2D	4	26.4	1445	IE2- 86.6	87.0	85.0	0.8	8.3	8.2	2.8	2.6	3.6	DMT 00 ATEX E 012 X	0.013	50
IE2-WE1R 112 M4 Ex II 2D	4.0	26.2	1460	IE2- 86.6	88.0	86.9	0.86	7.6	8.3	2.6	2.3	3.9	IBExU04ATEX1118	0.017	56
IE2-WE1R 132 S4 Ex II 2D	5.5	35.7	1470	IE2- 89.8	89.9	88.4	0.87	10	7.4	2.3	1.9	3.4	IBExU04ATEX1118	0.035	87
IE2-WE2R 132 S4 Ex II 2D	5.5	36.2	1450	IE2- 88.4	89.3	89.0	0.87	10.5	7.7	2.3	1.8	3.5	IBExU04ATEX1118	0.020	64
IE2-WE1R 132 M4 Ex II 2D	7.5	48.7	1470	IE2- 89.9	90.0	88.5	0.82	14.5	8.5	2.6	2.1	4.0	IBExU04ATEX1118	0.035	88
IE2-WE1R 160 M4 Ex II 2D	11.0	71	1475	IE2- 90.6	90.3	88.5	0.82	21.5	8.1	3.1	2.4	3.4	IBExU04ATEX1118	0.078	122
IE2-WE2R 160 M4 Ex II 2D	11	71.5	1470	IE2- 90.3	90.3	88.5	0.78	22.5	7.8	2.4	2.1	3.9	IBExU04ATEX1118	0.043	105
IE2-WE1R 160 L4 Ex II 2D	15.0	97	1470	IE2- 90.6	90.9	90.5	0.87	27.5	8.3	2.7	2.2	3.2	IBExU04ATEX1118	0.115	160
IE2-WE2R 160 L4 Ex II 2D	15	97	1480	IE2- 92.0	92.0	90.6	0.84	28	9.1	3.0	2.5	3.9	IBExU04ATEX1118	0.115	161
IE2-WE1R 180 M4 Ex II 2D	18.5	120	1475	IE2- 91.5	91.5	90.4	0.86	34	6.8	1.8	1.5	2.7	IBExU04ATEX1118	0.168	207
IE2-WE2R 180 M4 Ex II 2D	18.5	120	1470	IE2- 91.2	90.6	89.3	0.78	37.5	6.4	2.0	1.6	2.8	IBExU04ATEX1118	0.138	176
IE2-WE1R 180 L4 Ex II 2D	22	142	1475	IE2- 91.6	91.4	89.9	0.83	42	7.3	2.1	1.7	3.0	IBExU04ATEX1118	0.168	215
IE2-WE1R 200 L4 Ex II 2D	30	194	1480	IE2- 92.3	91.3	88.2	0.80	58.5	7.3	2.1	1.7	2.9	IBExU04ATEX1118	0.275	277
IE2-WE1R 225 S4 Ex II 2D	37	240	1475	IE2- 92.7	91.8	90.7	0.84	68.5	7.4	2.2	1.7	2.7	IBExU04ATEX1118	0.313	313
IE2-WE1R 225 M4 Ex II 2D	45	290	1483	IE2- 93.1	93.0	91.1	0.84	83	7.9	2.3	1.9	2.4	IBExU04ATEX1118	0.525	390
IE2-WE2R 225 M4 Ex II 2D	45	291	1475	IE2- 93.1	92.9	92.1	0.80	87	7.6	2.6	1.9	3.1	IBExU04ATEX1118	0.356	346
IE2-WE1R 250 M4 Ex II 2D	55	354	1485	IE2- 94.0	94.1	92.5	0.84	101	8.0	2.0	1.7	2.3	IBExU04ATEX1118	0.95	535
IE2-WE2R 250 M4 Ex II 2D	55	356	1477	IE2- 93.9	93.8	93.7	0.82	103	7.5	2.4	1.9	2.4	IBExU04ATEX1118	0.62	435
IE2-WE1R 280 S4 Ex II 2D	75	482	1485	IE2- 94.2	94.4	92.1	0.84	137	7.2	1.8	1.6	2.1	IBExU04ATEX1118	0.95	550
IE2-WE1R 280 M4 Ex II 2D	90	580	1483	IE2- 94.3	94.5	94.0	0.84	164	7.6	1.8	1.6	2.3	IBExU04ATEX1118	1.10	610
IE2-W21R 315 S4 Ex II 2D	110	707	1485	IE2- 94.8	94.8	94.0	0.82	204	8.5	1.8	1.5	2.7	IBExU04ATEX1118	1.96	760
IE2-W21R 315 M4 Ex II 2D	132	849	1484	IE2- 95.0	95.0	94.5	0.83	242	8.2	1.8	1.6	2.3	IBExU04ATEX1118	2.27	850
IE2-W21R 315 MX4 Ex II 2D	160	1031	1482	IE2- 95.0	95.0	94.5	0.84	289	7.4	1.6	1.4	2.2	IBExU04ATEX1118	2.73	975
IE2-W21R 315 MY4 Ex II 2D	200	1282	1490	IE2- 95.1	95.1	94.5	0.87	349	8.5	1.8	1.6	2.5	IBExU04ATEX1118	4.82	1270
IE2-W21R 315 L4 Ex II 2D	250	1602	1490	IE2- 95.4	95.4	95.3	0.88	430	9.0	2.2	1.5	2.7	IBExU04ATEX1118	5.93	1450
IE2-W21R 315 LX4 Ex II 2D	315	2019	1490	IE2- 95.4	95.4	95.0	0.88	542	9.0	2.4	1.6	2.6	IBExU04ATEX1118	6.82	1630
IE2-W22R 355 M4 Ex II 2D	355	2271	1493	IE2- 95.5	95.5	95.0	0.87	617	8.0	1.3	1.0	2.7	IBExU04ATEX1118	7.90	2150
IE2-W22R 355 MX4 Ex II 2D	400	2557	1494	IE2- 95.5	95.5	95.5	0.88	687	8.5	1.3	1.0	3.0	IBExU04ATEX1118	9.50	2400
IE2-W22R 355 L4 Ex II 2D	450	2873	1496	IE2- 95.5	95.5	95.5	0.86	790	8.5	1.4	0.8	2.9	IBExU04ATEX1118	10.00	2500

Other voltages and frequencies upon request. Changes are possible for motors which are not yet certified.

Three-phase motors with squirrel-cage rotor, High Efficiency IE2 Type of explosion protection – Protection by enclosure „tb“ for operation in Zone 21 according to EN 60079-31

Ex II 2D Ex tb IIIC T125 °C Db

for rated voltage, temperature classes T1, T2 and T3
with surface cooling, duty type S1, continuous duty
thermal class F, degree of protection IP 55, 50 Hz

Motor selection data														Design point 400 V, 50 Hz	
Type	P	M _B	n _B	η _B			cosφ _B	I _B	I _A /I _B	M _A /M _B	M _S /M _B	M _K /M _B	Certificate no. IBEJU...	J	m
	kW	Nm	rpm	100 %	75 %	50 %	-	A	-	-	-	-	-	kgm ²	kg
Synchronous speed 1000 rpm – 6-pole version															
IE2-KPR 90 S6 Ex II 2D	0.75	7.5	955	IE2- 75.9	78.3	75.1	0.71	1.95	4.9	2.4	2.3	2.6	DMT 00 ATEX E 012 X	0.00625	24
IE2-KPR 90 LW6 Ex II 2D	1.1	11	955	IE2- 78.1	78.0	75.1	0.69	2.95	4.7	2.5	2.4	2.8	DMT 00 ATEX E 012 X	0.00625	24
IE2-KPR 90 L6 Ex II 2D	1.1	11	955	IE2- 78.1	82.0	79.3	0.71	2.75	5.4	2.5	2.4	2.8	DMT 00 ATEX E 012 X	0.0072	30
IE2-KPR 100 LW6 Ex II 2D	1.1	10.94	960	IE2- 78.1	***	***	0.76	2.5	6.5	2.8	2.7	3.4	DMT 00 ATEX E 012 X	0.0139	36
IE2-KPR 100 LX6 Ex II 2D	1.5	15	955	IE2- 79.8	83.5	81.5	0.76	3.45	5.9	2.3	2.2	2.8	DMT 00 ATEX E 012 X	0.0139	36
IE2-KPER 112 MX6 Ex II 2D	2.2	21.89	960	IE2- 81.8	***	***	0.65	5.9	6.4	3.0	2.9	3.7	DMT 00 ATEX E 012 X	***	37
IE2-KPER 112 MV6 Ex II 2D	2.2	22	955	IE2- 81.8	82.5	79.8	0.75	5.15	5.7	2.4	2.3	2.9	DMT 00 ATEX E 012 X	0.0155	48
IE2-KPER 112 MZ6 ExnA IIC T3 Gc	3	30	955	IE2- 83.3	83.1	80.5	0.75	6.85	6.5	2.8	2.7	3.5	DMT 00 ATEX E 012 X	0.043	50
IE2-KPER 132 SX6T Ex II 2D	3	30	955	IE2- 83.3	83.1	80.5	0.73	7.1	7.0	3.2	3.1	4.0	DMT 00 ATEX E 012 X	0.0165	52
IE2-W21R 132 S6 Ex II 2D	3.0	29.8	963	IE2- 84.9	85.2	83.9	0.80	6.4	6.0	2.0	1.3	3.0	IBExU04ATEX1118	0.023	55
IE2-W21R 132 M6 Ex II 2D	4.0	39.6	965	IE2- 85.5	85.5	83.8	0.79	8.5	5.1	1.8	1.6	2.4	IBExU04ATEX1118	0.043	76
IE2-WE2R 132 M6 Ex II 2D	4	40	955	IE2- 85.1	86.0	85.2	0.82	8.3	5.7	2.1	2.0	2.9	IBExU04ATEX1118	0.029	66
IE2-W21R 132 MX6 Ex II 2D	5.5	54	970	IE2- 86.1	85.5	82.4	0.77	12	5.7	2.2	1.7	2.7	IBExU04ATEX1118	0.053	85
IE2-W21R 160 M6 Ex II 2D	7.5	73	975	IE2- 87.4	88.1	86.0	0.81	15.5	6.3	2.5	2.1	2.9	IBExU04ATEX1118	0.113	118
IE2-WE2R 160 M6 Ex II 2D	7.5	74	970	IE2- 87.5	87.6	85.9	0.79	15.5	5.9	2.1	1.8	2.9	IBExU04ATEX1118	0.053	103
IE2-W21R 160 L6 Ex II 2D	11.0	108	970	IE2- 88.7	87.9	86.3	0.85	21	5.8	2.2	1.9	2.7	IBExU04ATEX1118	0.145	135
IE2-WE1R 160 L6 Ex II 2D	11.0	108	975	IE2- 88.9	88.8	87.0	0.81	22	6.8	2.7	2.4	3.1	IBExU04ATEX1118	0.166	155
IE2-W21R 180 L6 Ex II 2D	15.0	147	975	IE2- 89.7	88.8	86.7	0.84	28.5	6.2	2.1	1.8	2.8	IBExU04ATEX1118	0.228	185
IE2-WE2R 180 L6 Ex II 2D	15	148	970	IE2- 89.7	88.8	87.8	0.83	29	5.6	2.3	1.7	2.6	IBExU04ATEX1118	0.166	157
IE2-W21R 200 L6 Ex II 2D	18.5	180	980	IE2- 90.4	88.8	86.5	0.85	35	6.6	2.3	1.7	2.9	IBExU04ATEX1118	0.268	208
IE2-W21R 200 LX6 Ex II 2D	22	214	980	IE2- 90.9	90.2	88.5	0.86	40.5	6.4	2.2	1.8	2.7	IBExU04ATEX1118	0.443	272
IE2-WE2R 200 LX6 Ex II 2D	22	215	975	IE2- 90.9	89.9	88.5	0.84	41.5	6.7	2.4	2.0	3.0	IBExU04ATEX1118	0.324	238
IE2-W21R 225 M6 Ex II 2D	30	291	985	IE2- 92.0	91.5	90.0	0.86	54.5	7.3	2.5	2.2	2.9	IBExU04ATEX1118	0.825	365
IE2-WE2R 225 M6 Ex II 2D	30	294	975	IE2- 91.7	91.4	90.6	0.87	54.5	6.7	2.3	1.9	2.8	IBExU04ATEX1118	0.514	308
IE2-W21R 250 M6 Ex II 2D	37	359	985	IE2- 92.2	91.7	90.7	0.85	68	6.4	2.7	1.8	2.4	IBExU04ATEX1118	1.28	480
IE2-WE2R 250 M6 Ex II 2D	37	361	979	IE2- 92.2	92.3	91.8	0.86	67.5	6.6	2.7	2.0	2.6	IBExU04ATEX1118	0.92	407
IE2-W21R 280 S6 Ex II 2D	45	437	983	IE2- 93.0	92.7	92.4	0.87	80.5	6.5	2.2	1.7	2.4	IBExU04ATEX1118	1.48	560
IE2-W21R 280 M6 Ex II 2D	55	531	990	IE2- 93.5	93.5	93.0	0.85	100	7.6	2.0	1.5	2.5	IBExU04ATEX1118	2.63	710
IE2-W21R 315 S6 Ex II 2D	75	723	990	IE2- 93.9	93.7	93.5	0.87	133	7.8	1.9	1.5	2.5	IBExU04ATEX1118	3.33	804
IE2-W21R 315 M6 Ex II 2D	90	868	990	IE2- 94.0	94.0	93.5	0.88	157	7.5	1.8	1.5	2.5	IBExU04ATEX1118	3.60	865
IE2-W21R 315 MX6 Ex II 2D	110	1061	990	IE2- 94.3	94.3	94.0	0.87	194	7.5	1.8	1.4	2.3	IBExU04ATEX1118	6.67	1210
IE2-W21R 315 MY6 Ex II 2D	132	1273	990	IE2- 94.6	94.3	94.0	0.87	231	7.5	1.9	1.4	2.2	IBExU04ATEX1118	6.67	1250
IE2-W21R 315 L6 Ex II 2D	160	1543	990	IE2- 94.8	94.5	93.5	0.88	277	7.5	2.0	1.5	2.4	IBExU04ATEX1118	8.60	1430
IE2-W21R 315 LX6 Ex II 2D	200	1929	990	IE2- 95.0	95.0	94.5	0.86	353	7.0	1.9	1.5	2.2	IBExU04ATEX1118	8.60	1460
IE2-W22R 355 M6 Ex II 2D	200	1920	995	IE2- 95.0	95.0	94.0	0.82	371	8.0	1.7	1.4	2.6	IBExU04ATEX1118	8.20	1850
IE2-W22R 355 MX6 Ex II 2D	315	3023	995	IE2- 95.0	95.0	94.5	0.85	447	7.5	1.6	1.2	2.5	IBExU04ATEX1118	12.1	2200
IE2-W22R 355 LY6 Ex II 2D	355	3407	995	IE2- 95.3	95.3	95.3	0.86	555	8.0	2.1	1.3	2.6	IBExU04ATEX1118	14.0	2400

Other voltages and frequencies upon request. Changes are possible for motors which are not yet certified.
***) upon request

Three-phase motors with squirrel-cage rotor, High Efficiency IE2
Type of explosion protection – Protection by enclosure „tb“
for operation in Zone 21 according to EN 60079-31

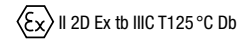

for rated voltage, temperature classes T1, T2 and T3
 with surface cooling, duty type S1, continuous duty
 thermal class F, degree of protection IP 55, 50 Hz

Motor selection data													Design point 400 V, 50 Hz		
Type	P kW	M _B Nm	n _B rpm	η _B (IEC/EN 60034-30-1)			cosφ _B -	I _B 400 V A	I _A /I _B -	M _A /M _B -	M _S /M _B -	M _K /M _B -	Certificate no. IBExU...	J	m
				100 %	75 %	50 %								kgm ²	kg
Synchronous speed 750 rpm – 8-pole version															
IE2-W21R 132 S8 Ex II 2D	2.2	29.2	720	IE2- 81.7	81.0	77.5	0.65	6	4.8	2.2	2.0	3.2	IBExU04ATEX1118	0.0180	55
IE2-W21R 132 M8 Ex II 2D	3.0	39.8	720	IE2- 82.7	83.0	81.3	0.74	7.1	3.9	1.6	1.3	1.9	IBExU04ATEX1118	0.0430	74
IE2-WE2R 132 M8 Ex II 2D	3	39.8	720	IE2- **)	**)	**)	**)	**)	**)	**)	**)	**)	IBExU04ATEX1118	0.0290	65
IE2-W21R 160 M8 Ex II 2D	4.0	53.2	718	IE2- 84.2	83.7	81.9	0.72	9.5	4.6	1.6	**)	2.5	IBExU04ATEX1118	0.0530	86
IE2-W21R 160 MX8 Ex II 2D	5.5	72.0	730	IE2- 86.9	86.6	84.1	0.72	12.5	4.8	2.1	1.8	2.6	IBExU04ATEX1118	0.1130	115
IE2-WE2R 160 MX8 Ex II 2D	5.5	73	715	IE2- 83.9	84.0	81.9	0.71	13.5	4.3	1.7	1.5	2.5	IBExU04ATEX1118	0.0530	103
IE2-W21R 160 L8 Ex II 2D	7.5	99	725	IE2- 87.5	87.0	83.5	0.77	16	5.5	2.0	**)	2.8	IBExU04ATEX1118	0.1450	136
IE2-W21R 180 L8 Ex II 2D	11.0	144	727	IE2- 88.2	88.2	86.7	0.78	23	4.9	1.8	1.6	2.4	IBExU04ATEX1118	0.2280	175
IE2-WE2R 180 L8 Ex II 2D	11	144	730	IE2- 87.9	87.4	85.2	0.67	25.5	4.3	1.9	1.6	2.3	IBExU04ATEX1118	0.1660	157
IE2-W21R 200 L8 Ex II 2D	15.0	197	727	IE2- 88.2	88.1	86.4	0.77	32	4.9	1.9	1.7	2.3	IBExU04ATEX1118	0.2680	200
IE2-W21R 225 S8 Ex II 2D	18.5	242	730	IE2- 89.6	89.4	87.2	0.78	38	5.4	2.1	2.0	2.8	IBExU04ATEX1118	0.440	265
IE2-WE2R 225 S8 Ex II 2D	18.5	240	735	IE2- 90.7	90.7	89.4	0.8	37	6.1	2.1	1.9	2.9	IBExU04ATEX1118	0.514	305
IE2-W21R 225 M8 Ex II 2D	22	287	733	IE2- 90.6	89.4	89.9	0.78	45	5.6	2.2	1.8	2.6	IBExU04ATEX1118	0.825	380
IE2-WE2R 225 M8 Ex II 2D	22	286	735	IE2- 90.3	90.3	88.7	0.77	45.5	6.1	2.2	2.0	2.9	IBExU04ATEX1118	0.514	307
IE2-W21R 250 M8 Ex II 2D	30	389	737	IE2- 92.1	92.4	91.6	0.79	59.5	5.0	2.0	1.6	2.1	IBExU04ATEX1118	1.350	480
IE2-WE2R 250 M8 Ex II 2D	30	391	732	IE2- 91.5	91.7	90.9	0.77	61.5	5.6	2.3	2.0	2.5	IBExU04ATEX1118	0.950	405
IE2-W21R 280 S8 Ex II 2D	37	479	737	IE2- 92.2	92.1	90.9	0.79	73.5	6.0	2.3	1.9	2.5	IBExU04ATEX1118	1.55	550
IE2-W21R 280 M8 Ex II 2D	45	581	740	IE2- 92.7	92.7	92.0	0.79	88.5	6.7	1.8	1.5	2.5	IBExU04ATEX1118	2.63	690
IE2-W21R 315 S8 Ex II 2D	55	710	740	IE2- 92.2	92.2	92.1	0.80	108	6.3	1.8	1.5	2.3	IBExU04ATEX1118	2.63	690
IE2-W21R 315 M8 Ex II 2D	75	968	740	IE2- 93.5	93.5	93.0	0.81	143	6.0	1.8	1.5	2.1	IBExU04ATEX1118	3.6	880
IE2-W21R 315 MX8 Ex II 2D	90	1161	740	IE2- 92.1	91.6	90.1	0.81	174	6.0	1.9	**)	2.2	IBExU04ATEX1118	6	1050
IE2-W21R 315 MY8 Ex II 2D	110	1420	740	IE2- 93.8	93.3	91.2	0.81	209	6.5	2.1	**)	2.4	IBExU04ATEX1118	6.76	1250
IE2-W21R 315 L8 Ex II 2D	132	1704	740	IE2- 94.4	94.0	93.5	0.83	243	7.5	2.2	1.8	2.5	IBExU04ATEX1118	8.71	1430
IE2-W21R 315 LX8 Ex II 2D	160	2065	740	IE2- 94.2	94.2	93.8	0.80	306	7.2	2.2	1.8	2.5	IBExU04ATEX1118	8.71	1430
IE2-W22R 355 M8 Ex II 2D	200	2571	743	IE2- 94.7	94.1	91.5	0.77	396	**)	**)	**)	**)	IBExU04ATEX1118	9.5	1850
IE2-W22R 355 MX8 Ex II 2D	250	3205	745	IE2- 95.8	95.8	95.5	0.83	454	7.0	1.2	1.0	2.6	IBExU04ATEX1118	13.4	2200
IE2-W22R 355 LY8 Ex II 2D	280	3599	743	IE2- 94.8	94.1	91.5	0.78	547	**)	**)	**)	**)	IBExU04ATEX1118	15.8	2400

Other voltages and frequencies upon request. Changes are possible for motors which are not yet certified.
 **) upon request

Three-phase motors with squirrel-cage rotor, Standard Efficiency IE1 Type of explosion protection – Protection by enclosure „tb“ for operation in Zone 21 according to EN 60079-31

II 2D Ex tb III C T125 °C Db

for rated voltage, temperature classes T1, T2 and T3
with surface cooling, duty type S1, continuous duty
thermal class F, degree of protection IP 55, 50 Hz

Motor selection data														Design point 400 V, 50 Hz	
Type	P kW	M _B Nm	n _B rpm	η _B (IEC/EN 60034-30-1)			cosφ _B -	I _B 400 V A	I _A /I _B -	M _A /M _B -	M _S /M _B -	M _K /M _B -	Certificate no. IBExU...	J	m
				100 %	75 %	50 %								kgm ²	kg
Synchronous speed 3000 rpm – 2-pole version															
IE1-KPEO 56 K2 Ex II 2D	0.09	0.3	2840	IE1- 70.2	68.1	64.5	0.74	0.25	4.9	2.3	2.3	2.8	DMT 00 ATEX E 012 X	0.00013	4.4
IE1-KPER 56 G2 Ex II 2D	0.12	0.41	2830	IE1- 70.3	67.0	60.1	0.77	0.32	4.5	2.1	2.1	2.3	DMT 00 ATEX E 012 X	0.00013	4.5
IE1-KPER 63 K2 Ex II 2D	0.18	0.62	2790	IE1- 67.0	65.6	59.8	0.76	0.51	4.1	1.9	1.9	2.2	DMT 00 ATEX E 012 X	0.00013	4.9
IE1-KPER 63 G2 Ex II 2D	0.25	0.85	2800	IE1- 67.7	64.9	56.2	0.72	0.74	4.2	2.2	2.2	2.4	DMT 00 ATEX E 012 X	0.00015	5.2
IE1-KPER 71 K2 Ex II 2D	0.37	1.27	2780	IE1- 71.9	70.8	65.0	0.79	0.94	4.4	2.1	2.1	2.3	DMT 00 ATEX E 012 X	0.00025	6.7
IE1-KPER 71 G2 Ex II 2D	0.55	1.89	2775	IE1- 74.2	75.0	72.0	0.81	1.32	5.1	2.3	2.1	2.6	DMT 00 ATEX E 012 X	0.00032	7.6
IE1-KPER 80 K2 Ex II 2D	0.75	2.54	2825	IE1- 76.8	77.5	74.3	0.82	1.72	5.9	2.4	2.4	2.4	DMT 00 ATEX E 012 X	0.00057	10.7
IE1-KPER 80 G2 Ex II 2D	1.1	3.71	2835	IE1- 76.9	75.9	73.3	0.81	2.55	6.0	2.4	2.3	2.6	DMT 00 ATEX E 012 X	0.00072	11.5
IE1-KPER 90 S2 Ex II 2D	1.5	5.04	2840	IE1- 81.2	82.2	80.3	0.86	3.1	7.0	2.5	2.5	2.8	DMT 00 ATEX E 012 X	0.00132	16.0
IE1-KPER 90 L2 Ex II 2D	2.2	7.37	2850	IE1- 82.1	83.4	81.9	0.85	4.55	7.5	2.8	2.3	2.9	DMT 00 ATEX E 012 X	0.0017	19.0
IE1-KPER 100 L2 Ex II 2D	3.0	10	2865	IE1- 82.8	83.1	83.3	0.85	6.15	6.8	2.4	2.2	2.8	DMT 00 ATEX E 012 X	0.00275	25.0
IE1-KPER 112 M2 Ex II 2D	4.0	13.2	2900	IE1- 84.9	85.5	84.4	0.81	8.4	7.0	2.2	2.1	2.9	DMT 00 ATEX E 012 X	0.0045	32
IE1-KPER 112 MX2 Ex II 2D	5.5	18.2	2890	IE1- 85.9	86.2	86.4	0.84	11.0	7.5	2.4	2.2	3.0	DMT 00 ATEX E 012 X	0.0055	40
IE1-KPER 132 S2T Ex II 2D	5.5	18.2	2890	IE1- 85.9	86.2	86.4	0.84	11.0	7.5	2.4	2.2	3.0	DMT 00 ATEX E 012 X	0.0055	40
IE1-KPER 132 SX2T Ex II 2D	7.5	24.9	2880	IE1- 87.1	87.2	86.6	0.84	14.8	6.3	1.5	1.2	2.6	DMT 00 ATEX E 012 X	0.0680	48
IE1-K11R 132 S2 Ex II 2D	5.5	18	2860	IE1- 84.7	84.7	82.4	0.86	11	5.5	1.8	1.6	2.2	IBExU09ATEX1065	0.0081	50
IE1-K11R 132 SX2 Ex II 2D	7.5	25	2900	IE1- 86.0	86.0	84.0	0.86	14.5	6.6	1.8	1.3	2.5	IBExU09ATEX1065	0.0110	59
IE1-K11R 160 M2 Ex II 2D	11.0	36	2900	IE1- 87.6	87.6	84.6	0.90	20	7.0	2.4	2.0	3.0	IBExU09ATEX1065	0.0258	88
IE1-K11R 160 MX2 Ex II 2D	15.0	49	2930	IE1- 88.7	88.7	85.8	0.90	27	7.1	2.2	1.7	2.9	IBExU09ATEX1065	0.0575	131
IE1-K11R 160 L2 Ex II 2D	18.5	61	2920	IE1- 89.3	88.3	85.8	0.92	32.5	7.2	2.1	1.6	2.8	IBExU09ATEX1065	0.0675	138
IE1-K11R 180 M2 Ex II 2D	22	72	2935	IE1- 89.9	89.1	86.1	0.92	38.5	6.8	1.7	1.4	2.6	IBExU09ATEX1065	0.105	178
IE1-K11R 200 L2 Ex II 2D	30	97	2940	IE1- 91.1	90.3	88.8	0.92	51.5	7.3	2.0	1.6	2.9	IBExU09ATEX1065	0.128	207
IE1-K11R 200 LX2 Ex II 2D	37	120	2940	IE1- 91.5	90.5	89.0	0.90	65	7.0	1.8	1.3	2.4	IBExU09ATEX1065	0.193	265
IE1-K11R 225 M2 Ex II 2D	45	146	2940	IE1- 92.0	91.3	88.8	0.91	77.5	7.5	1.8	1.4	2.7	IBExU09ATEX1065	0.220	295
IE1-K11R 250 M2 Ex II 2D	55	178	2955	IE1- 92.2	91.0	89.0	0.91	94.5	7.5	2.0	1.5	2.6	IBExU09ATEX1065	0.375	383
IE1-K11R 280 S2 Ex II 2D	75	241	2970	IE1- 93.1	92.0	90.5	0.92	126	7.5	2.0	1.6	2.6	IBExU09ATEX1065	0.650	505
IE1-K11R 280 M2 Ex II 2D	90	289	2970	IE1- 93.2	92.7	90.5	0.91	153	8.5	2.2	1.8	2.8	IBExU09ATEX1065	0.675	546
IE1-K11R 315 S2 Ex II 2D	110	353	2975	IE1- 93.5	92.6	91.1	0.91	187	8.5	1.5	1.3	2.5	IBExU09ATEX1065	1.21	720
IE1-K11R 315 M2 Ex II 2D	132	424	2975	IE1- 93.8	92.9	91.9	0.91	223	8.5	2.0	1.8	2.7	IBExU09ATEX1065	1.44	800
IE1-K11R 315 MX2 Ex II 2D	160	514	2975	IE1- 94.0	94.0	94.0	0.91	270	8.5	1.5	1.0	2.0	IBExU09ATEX1065	1.76	980
IE1-K11R 315 MY2 Ex II 2D	200	643	2970	IE1- 94.0	93.2	92.5	0.92	334	8.2	2.6	2.0	2.6	IBExU09ATEX1065	2.82	1170
IE1-K11R 315 L2 Ex II 2D	250	803	2973	IE1- 94.1	93.2	93.0	0.93	412	7.3	2.1	1.4	2.0	IBExU09ATEX1065	3.66	1460
IE1-K11R 315 LX2 Ex II 2D	315	1010	2980	IE1- 94.5	94.5	92.8	0.92	523	8.6	2.7	1.7	2.4	IBExU09ATEX1065	4.43	1630
IE1-K12R 355 MY2G Ex II 2D	315	1007	2988	IE1- 94.5	94.3	93.7	0.88	547	8.6	1.3	1.0	3.0	IBExU09ATEX1065	4.10	1900
IE1-K12R 355 M2G Ex II 2D	355	1138	2980	IE1- 94.3	94.3	93.8	0.91	597	7.3	1.3	1.0	2.3	IBExU09ATEX1065	4.20	2000
IE1-K12R 355 MX2G Ex II 2D	400	1280	2985	IE1- 94.6	94.5	93.8	0.90	678	8.5	1.9	1.3	3.2	IBExU09ATEX1065	5.50	2200
IE1-K12R 355 L2G Ex II 2D	450	1441	2983	IE1- 94.7	94.5	93.8	0.92	746	7.2	1.3	1.0	2.4	IBExU09ATEX1065	7.10	2400

Progressive series KPR/K10R possible upon request
Other voltages and frequencies upon request. Changes are possible for motors which are not yet certified.

Three-phase motors with squirrel-cage rotor, Standard Efficiency IE1
Type of explosion protection – Protection by enclosure „tb“
for operation in Zone 21 according to EN 60079-31

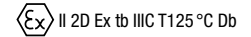

for rated voltage, temperature classes T1, T2 and T3
 with surface cooling, duty type S1, continuous duty
 thermal class F, degree of protection IP 55, 50 Hz

Motor selection data													Design point 400 V, 50 Hz		
Type	P kW	M _B Nm	n _B rpm	η _B (IEC/EN 60034-30-1)			cosφ _B -	I _B 400 V A	I _A /I _B -	M _A /M _B -	M _S /M _B -	M _K /M _B -	Certificate no. IBExU...	J kgm ²	m kg
				100 %	75 %	50 %									
Synchronous speed 1500 rpm – 4-pole version															
IE1-KPE0 56 K4 Ex II 2D	0.06	0.41	1410	IE1- 60.1	56.5	49.6	0.60	0.24	3.1	2.3	2.3	2.7	DMT 00 ATEX E 012 X	0.00019	4.3
IE1-KPER 56 G4 Ex II 2D	0.09	0.63	1375	IE1- 61.6	58.7	53.0	0.68	0.31	3.2	1.9	1.9	2.2	DMT 00 ATEX E 012 X	0.00019	4.4
IE1-KPER 63 K4 Ex II 2D	0.12	0.84	1370	IE1- 57.9	51.2	42.2	0.68	0.44	3.2	1.9	1.8	2.2	DMT 00 ATEX E 012 X	0.00019	4.8
IE1-KPER 63 G4 Ex II 2D	0.18	1.26	1360	IE1- 60.6	57.5	49.4	0.66	0.65	3.3	2.0	2.0	2.3	DMT 00 ATEX E 012 X	0.00024	5.2
IE1-KPER 71 K4 Ex II 2D	0.25	1.72	1385	IE1- 64.3	63.2	58.2	0.72	0.78	3.6	1.8	1.8	2.1	DMT 00 ATEX E 012 X	0.00040	6.8
IE1-KPER 71 G4 Ex II 2D	0.37	2.58	1370	IE1- 68.1	66.7	62.0	0.74	1.06	3.8	2.0	2.0	2.2	DMT 00 ATEX E 012 X	0.00050	7.8
IE1-KPER 80 K4 Ex II 2D	0.55	3.75	1400	IE1- 71.9	70.7	64.1	0.69	1.6	4.1	2.1	2.0	2.3	DMT 00 ATEX E 012 X	0.00087	10.6
IE1-KPER 80 G4 Ex II 2D	0.75	5.12	1400	IE1- 73.6	72.2	66.8	0.70	2.1	4.6	2.2	2.1	2.3	DMT 00 ATEX E 012 X	0.00107	11.7
IE1-KPER 90 S4 Ex II 2D	1.1	7.45	1410	IE1- 76.7	76.8	73.6	0.79	2.62	5.5	2.3	2.2	2.5	DMT 00 ATEX E 012 X	0.00207	15.5
IE1-KPER 90 L4 Ex II 2D	1.5	10.2	1400	IE1- 78.6	79.1	76.9	0.81	3.4	5.5	2.5	2.4	2.6	DMT 00 ATEX E 012 X	0.00260	18.0
IE1-KPER 100 L4 Ex II 2D	2.2	14.9	1410	IE1- 80.2	80.7	79.5	0.80	4.95	6.0	2.5	2.3	2.7	DMT 00 ATEX E 012 X	0.00400	23.5
IE1-KPER 100 LX4 Ex II 2D	3.0	20	1430	IE1- 82.4	82.8	80.8	0.79	6.65	6.5	2.5	2.2	2.9	DMT 00 ATEX E 012 X	0.00725	30
IE1-KPER 112 M4 Ex II 2D	4.0	26.6	1435	IE1- 84.1	85.1	83.6	0.78	8.8	6.9	2.6	2.5	3.2	DMT 00 ATEX E 012 X	0.009	37
IE1-KPER 112 MX4 Ex II 2D	5.5	36.9	1425	IE1- 85.2	86.5	85.8	0.79	11.8	6.3	2.5	2.4	2.9	DMT 00 ATEX E 012 X	0.011	47
IE1-KPER 132 S4T Ex II 2D	5.5	36.9	1425	IE1- 85.2	86.5	85.8	0.79	11.8	6.3	2.5	2.4	2.9	DMT 00 ATEX E 012 X	0.011	47
IE1-K11R 132 S4 Ex II 2D	5.5	36	1440	IE1- 84.9	84.9	83.4	0.89	10.5	6.5	1.9	1.7	3.0	IBExU09ATEX1065	0.015	51
IE1-K11R 132 M4 Ex II 2D	7.5	49	1450	IE1- 86.5	85.5	84.0	0.84	15	6.0	2.0	1.7	2.9	IBExU09ATEX1065	0.028	73
IE1-K11R 160 M4 Ex II 2D	11.0	72	1450	IE1- 88.0	87.6	85.6	0.85	21	6.8	2.2	1.9	3.3	IBExU09ATEX1065	0.035	92
IE1-K11R 160 L4 Ex II 2D	15.0	98	1465	IE1- 88.7	88.3	85.8	0.86	28.5	7.3	2.5	2.0	3.0	IBExU09ATEX1065	0.078	132
IE1-K11R 180 M4 Ex II 2D	18.5	121	1460	IE1- 89.3	88.8	86.8	0.86	35	6.8	2.5	2.0	2.9	IBExU09ATEX1065	0.090	145
IE1-K11R 180 L4 Ex II 2D	22	143	1465	IE1- 89.9	89.9	88.4	0.84	42	6.5	2.0	1.8	2.6	IBExU09ATEX1065	0.138	185
IE1-K11R 200 L4 Ex II 2D	30	196	1465	IE1- 90.7	90.2	89.2	0.85	56	7.0	2.0	1.7	2.4	IBExU09ATEX1065	0.168	211
IE1-K11R 225 S4 Ex II 2D	37	240	1470	IE1- 91.2	90.2	89.2	0.86	68	7.0	2.0	1.7	2.5	IBExU09ATEX1065	0.275	282
IE1-K11R 225 M4 Ex II 2D	45	292	1470	IE1- 91.7	91.2	89.7	0.86	82.5	7.0	2.0	1.7	2.5	IBExU09ATEX1065	0.313	323
IE1-K11R 250 M4 Ex II 2D	55	356	1475	IE1- 92.3	91.8	90.8	0.86	100	7.0	2.2	1.7	2.3	IBExU09ATEX1065	0.525	394
IE1-K11R 280 S4 Ex II 2D	75	484	1480	IE1- 92.7	92.1	90.6	0.86	136	7.0	2.0	1.7	2.2	IBExU09ATEX1065	0.950	540
IE1-K11R 280 M4 Ex II 2D	90	581	1480	IE1- 93.3	92.2	89.7	0.86	162	7.0	2.1	1.6	2.2	IBExU09ATEX1065	1.10	610
IE1-K11R 315 S4 Ex II 2D	110	707	1485	IE1- 93.5	92.9	91.4	0.86	197	7.5	1.8	1.6	2.2	IBExU09ATEX1065	1.96	740
IE1-K11R 315 M4 Ex II 2D	132	849	1485	IE1- 93.5	92.9	91.9	0.86	237	7.0	1.8	1.5	2.2	IBExU09ATEX1065	2.27	840
IE1-K11R 315 MX4 Ex II 2D	160	1032	1480	IE1- 93.8	93.6	92.8	0.87	283	7.0	1.8	1.5	2.0	IBExU09ATEX1065	2.73	1000
IE1-K11R 315 MY4 Ex II 2D	200	1286	1485	IE1- 94.3	93.3	92.8	0.88	348	7.5	2.0	1.8	2.4	IBExU09ATEX1065	4.82	1200
IE1-K11R 315 L4 Ex II 2D	250	1608	1485	IE1- 94.3	93.2	92.7	0.90	425	8.0	2.0	1.6	2.3	IBExU09ATEX1065	5.93	1510
IE1-K11R 315 LX4 Ex II 2D	315	2019	1490	IE1- 94.5	93.5	93.2	0.88	547	8.6	1.9	1.5	2.5	IBExU09ATEX1065	6.82	1630
IE1-K12R 355 MY4 Ex II 2D	315	2016	1492	IE1- 94.0	93.9	92.4	0.85	569	7.1	1.4	1.0	2.9	IBExU09ATEX1065	5.60	1950
IE1-K12R 355 M4 Ex II 2D	355	2275	1490	IE1- 94.5	94.2	93.2	0.84	646	8.1	1.8	1.0	3.1	IBExU09ATEX1065	7.9	2150
IE1-K12R 355 MX4 Ex II 2D	400	2557	1494	IE1- 94.5	94.4	93.7	0.84	727	8.6	1.3	1.0	3.0	IBExU09ATEX1065	9.5	2400
IE1-K12R 355 L4 Ex II 2D	450	2884	1490	IE1- 94.5	94.4	93.7	0.82	838	8.0	1.2	1.0	3.0	IBExU09ATEX1065	10.0	2500

Progressive series KPR/K10R possible upon request
 Other voltages and frequencies upon request. Changes are possible for motors which are not yet certified.

Three-phase motors with squirrel-cage rotor, Standard Efficiency IE1 Type of explosion protection – Protection by enclosure „tb“ for operation in Zone 21 according to EN 60079-31

II 2D Ex tb III C T125 °C Db

for rated voltage, temperature classes T1, T2 and T3
with surface cooling, duty type S1, continuous duty
thermal class F, degree of protection IP 55, 50 Hz

Motor selection data													Design point 400 V, 50 Hz		
Type	P kW	M _B Nm	n _B rpm	η _B (IEC/EN 60034-30-1)			cosφ _B -	I _B 400 V A	I _A /I _B -	M _A /M _B -	M _S /M _B -	M _K /M _B -	Certificate no. IBExU...	J kgm ²	m kg
				100 %	75 %	50 %									
Synchronous speed 1000 rpm – 6-pole version															
IE1-KPER 63 K6 Ex II 2D	0.09	0.96	895	IE1- 50.4	46.2	38.4	0.56	0.46	2.5	2.0	2.0	2.4	DMT 00 ATEX E 012 X	0.00024	4.9
IE1-KPER 63 G6 Ex II 2D	0.12	1.3	880	IE1- 52.4	50.1	43.2	0.56	0.59	2.5	2.0	2.0	2.3	DMT 00 ATEX E 012 X	0.00027	5.7
IE1-KPER 71 K6 Ex II 2D	0.18	1.86	925	IE1- 57.9	53.9	45.4	0.51	0.88	2.8	1.6	1.6	2.1	DMT 00 ATEX E 012 X	0.00045	7.4
IE1-KPER 71 G6 Ex II 2D	0.25	2.61	915	IE1- 59.6	57.5	49.5	0.55	1.1	2.9	2.0	2.0	2.2	DMT 00 ATEX E 012 X	0.00060	8.3
IE1-KPER 80 K6 Ex II 2D	0.37	3.86	915	IE1- 66.3	64.5	57.1	0.66	1.22	3.4	2.0	2.0	2.0	DMT 00 ATEX E 012 X	0.00130	11.0
IE1-KPER 80 G6 Ex II 2D	0.55	5.74	915	IE1- 68.5	67.0	60.7	0.67	1.73	3.7	2.2	2.2	2.4	DMT 00 ATEX E 012 X	0.00175	12.5
IE1-KPER 90 S6 Ex II 2D	0.75	7.66	935	IE1- 70.5	68.8	63.2	0.64	2.4	4.5	2.4	2.4	2.6	DMT 00 ATEX E 012 X	0.00325	16.0
IE1-KPER 90 L6 Ex II 2D	1.1	11.24	935	IE1- 73.4	73.0	68.4	0.68	3.18	4.6	2.2	2.2	2.6	DMT 00 ATEX E 012 X	0.00425	19.0
IE1-KPER 100 L6 Ex II 2D	1.5	15.16	945	IE1- 76.0	75.2	71.1	0.73	3.9	4.6	2.1	2.0	2.4	DMT 00 ATEX E 012 X	0.00625	24.0
IE1-KPER 112 M6 Ex II 2D	2.2	22.12	950	IE1- 78.1	78.8	75.8	0.76	5.35	5.3	2.2	2.1	2.7	DMT 00 ATEX E 012 X	0.01225	33.5
IE1-KPER 132 S6T Ex II 2D	3.0	30.6	935	IE1- 81.9	82.8	81.4	0.75	7.05	5.2	2.5	2.5	2.9	DMT 00 ATEX E 012 X	0.0139	39.0
IE1-K11R 132 S6 Ex II 2D	3.0	30	955	IE1- 79.7	79.7	76.2	0.82	6.6	5.7	1.8	1.6	2.7	IBExU09ATEX1065	0.0180	46
IE1-K11R 132 M6 Ex II 2D	4.0	40	955	IE1- 81.4	80.4	75.4	0.80	8.9	6.0	2.2	2.0	3.1	IBExU09ATEX1065	0.0230	56
IE1-K11R 132 MX6 Ex II 2D	5.5	55	955	IE1- 83.3	83.3	81.3	0.83	11.5	5.0	1.8	1.5	2.3	IBExU09ATEX1065	0.0430	72
IE1-K11R 160 M6 Ex II 2D	7.5	75	960	IE1- 85.0	84.0	80.0	0.82	15.5	5.5	2.0	1.6	2.5	IBExU09ATEX1065	0.0530	91
IE1-K11R 160 L6 Ex II 2D	11.0	109	965	IE1- 86.4	86.2	84.2	0.86	21.5	5.0	2.0	1.7	2.3	IBExU09ATEX1065	0.1130	122
IE1-K11R 180 L6 Ex II 2D	15.0	148	965	IE1- 87.7	86.7	83.7	0.83	29.5	6.0	2.4	2.1	2.7	IBExU09ATEX1065	0.1450	142
IE1-K11R 200 L6 Ex II 2D	18.5	182	970	IE1- 88.6	88.5	86.5	0.87	34.5	5.5	2.0	1.7	2.4	IBExU09ATEX1065	0.2280	190
IE1-K11R 200 LX6 Ex II 2D	22	217	970	IE1- 89.2	88.9	86.4	0.87	41	6.2	2.2	1.8	2.6	IBExU09ATEX1065	0.2680	208
IE1-K11R 225 M6 Ex II 2D	30	295	973	IE1- 90.2	89.8	87.8	0.89	54	6.5	2.2	1.7	2.5	IBExU09ATEX1065	0.4430	284
IE1-K11R 250 M6 Ex II 2D	37	362	975	IE1- 90.8	90.6	87.8	0.89	66	6.5	2.2	1.7	2.3	IBExU09ATEX1065	0.8250	376
IE1-K11R 280 S6 Ex II 2D	45	439	980	IE1- 91.4	91.4	89.4	0.87	81.5	6.0	2.0	1.5	2.0	IBExU09ATEX1065	1.28	465
IE1-K11R 280 M6 Ex II 2D	55	536	980	IE1- 91.9	91.4	89.4	0.88	98	6.5	2.3	1.7	2.4	IBExU09ATEX1065	1.48	575
IE1-K11R 315 S6 Ex II 2D	75	727	985	IE1- 92.7	92.0	91.0	0.87	134	7.0	2.0	1.6	2.4	IBExU09ATEX1065	2.63	690
IE1-K11R 315 M6 Ex II 2D	90	868	990	IE1- 93.4	92.5	91.0	0.88	158	7.0	2.0	1.7	2.4	IBExU09ATEX1065	3.33	800
IE1-K11R 315 MX6 Ex II 2D	110	1061	990	IE1- 93.3	93.1	91.6	0.88	193	7.5	2.2	1.7	2.6	IBExU09ATEX1065	3.60	880
IE1-K11R 315 MY6 Ex II 2D	132	1273	990	IE1- 94.0	93.7	92.5	0.88	230	7.5	2.0	1.7	2.4	IBExU09ATEX1065	6.00	1050
IE1-K11R 315 L6 Ex II 2D	160	1551	985	IE1- 94.3	94.0	92.8	0.89	275	7.5	2.3	1.9	2.4	IBExU09ATEX1065	6.67	1250
IE1-K11R 315 LX6 Ex II 2D	200	1929	990	IE1- 94.2	93.9	93.2	0.87	352	8.3	2.2	2.0	2.7	IBExU09ATEX1065	8.6	1460
IE1-K12R 355 MY6 Ex II 2D	180	1735	990	IE1- 94.0	94.1	95.3	0.86	321	8.5	2.5	1.6	2.6	IBExU09ATEX1065	8.1	1550
IE1-K12R 355 M6 Ex II 2D	250	2402	994	IE1- 94.5	94.2	93.3	0.81	471	7.0	1.8	1.3	2.3	IBExU09ATEX1065	8.2	1850
IE1-K12R 355 MX6 Ex II 2D	315	3023	995	IE1- 94.5	94.5	93.8	0.83	580	6.8	1.6	1.3	2.5	IBExU09ATEX1065	12.1	2200
IE1-K12R 355 LY6 Ex II 2D	355	3407	995	IE1- 94.4	94.2	92.4	0.78	696	7.4	1.9	1.4	2.6	IBExU09ATEX1065	14.0	2400

Progressive series KPR/K10R possible upon request

Other voltages and frequencies upon request. Changes are possible for motors which are not yet certified.

Three-phase motors with squirrel-cage rotor, Standard Efficiency IE1
Type of explosion protection – Protection by enclosure „tb“
for operation in Zone 21 according to EN 60079-31

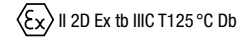

for rated voltage, temperature classes T1, T2 and T3
 with surface cooling, duty type S1, continuous duty
 thermal class F, degree of protection IP 55, 50 Hz

Motor selection data														Design point 400 V, 50 Hz	
Type	P kW	M _B Nm	n _B rpm	η _B (IEC/EN 60034-30-1)			cosφ _B -	I _B 400 V A	I _A /I _B -	M _A /M _B -	M _S /M _B -	M _K /M _B -	Certificate no. IBExU...	J	m
				100 %	75 %	50 %								kgm ²	kg
Synchronous speed 750 rpm – 8-pole version															
IE1-KPER 71 K8 Ex II 2D	0.09	1.27	675	- 45.5	42.1	34.8	0.51	0.56	2.1	1.9	1.9	2.1	DMT 00 ATEX E 012 X	0.00050	6.6
IE1-KPER 71 G8 Ex II 2D	0.12	1.71	670	- 46.5	42.1	33.7	0.51	0.73	2.3	1.8	1.8	2.1	DMT 00 ATEX E 012 X	0.00060	8.1
IE1-KPER 80 K8 Ex II 2D	0.18	2.49	690	- 56.5	53.4	45.0	0.59	0.78	2.8	2.0	2.0	2.2	DMT 00 ATEX E 012 X	0.00130	10.5
IE1-KPER 80 G8 Ex II 2D	0.25	3.44	695	- 57.5	54.1	46.1	0.56	1.12	3.0	2.3	2.3	2.5	DMT 00 ATEX E 012 X	0.00175	12.0
IE1-KPER 90 S8 Ex II 2D	0.37	5.05	700	- 61.8	59.7	52.8	0.54	1.60	3.0	1.9	1.9	2.1	DMT 00 ATEX E 012 X	0.00300	15.0
IE1-KPER 90 L8 Ex II 2D	0.55	7.56	695	- 64.8	62.5	55.8	0.60	2.04	3.2	1.9	1.9	2.2	DMT 00 ATEX E 012 X	0.00375	18.0
IE1-KPER 100 L8 Ex II 2D	0.75	10.2	705	- 66.8	64.7	57.9	0.60	2.70	3.3	1.8	1.8	2.2	DMT 00 ATEX E 012 X	0.00625	23.0
IE1-KPER 100 LX8 Ex II 2D	1.1	14.9	705	- 72.9	73.3	69.6	0.67	3.25	4.0	2.0	2.0	2.4	DMT 00 ATEX E 012 X	0.00900	28.0
IE1-KPER 112 M8 Ex II 2D	1.5	20.3	705	- 75.4	75.7	72.4	0.70	4.10	4.4	2.2	2.1	2.5	DMT 00 ATEX E 012 X	0.01225	33.5
IE1-KPER 132 S8T Ex II 2D	2.2	31	685	- 74.1	74.8	72.4	0.68	6.30	3.8	2.0	1.9	2.3	DMT 00 ATEX E 012 X	0.01390	39.0
IE1-K11R 132 S8 Ex II 2D	2.2	30	705	IE1- 75.5	75.0	72.0	0.76	5.5	4.5	1.7	1.6	2.3	IBExU09ATEX1065	0.01800	46
IE1-K11R 132 M8 Ex II 2D	3.0	41	705	IE1- 78.0	78.0	75.0	0.75	7.4	4.5	1.7	1.6	2.3	IBExU09ATEX1065	0.0230	53
IE1-K11R 160 M8 Ex II 2D	4.0	54	710	IE1- 79.3	79.0	77.0	0.78	9.3	4.0	1.6	1.3	1.9	IBExU09ATEX1065	0.0430	70
IE1-K11R 160 MX8 Ex II 2D	5.5	74	710	IE1- 81.4	81.0	78.0	0.78	12.5	4.5	1.7	1.6	2.1	IBExU09ATEX1065	0.0530	86
IE1-K11R 160 L8 Ex II 2D	7.5	99	725	IE1- 83.0	83.0	79.0	0.78	16.5	4.5	1.8	1.6	2.1	IBExU09ATEX1065	0.1130	114
IE1-K11R 180 L8 Ex II 2D	11.0	146	720	IE1- 85.0	84.0	81.5	0.78	24	4.5	2.0	1.7	2.1	IBExU09ATEX1065	0.1450	136
IE1-K11R 200 L8 Ex II 2D	15.0	198	725	IE1- 86.5	86.0	83.0	0.79	31.5	5.0	2.0	1.7	2.3	IBExU09ATEX1065	0.228	175
IE1-K11R 225 S8 Ex II 2D	18.5	244	725	IE1- 89.2	88.0	86.0	0.83	36	5.5	2.0	1.6	2.2	IBExU09ATEX1065	0.440	265
IE1-K11R 225 M8 Ex II 2D	22	290	725	IE1- 89.2	89.0	88.5	0.84	42.5	5.0	1.8	1.5	2.2	IBExU09ATEX1065	0.440	265
IE1-K11R 250 M8 Ex II 2D	30	393	730	IE1- 89.7	89.5	86.5	0.79	61	5.5	2.2	1.8	2.2	IBExU09ATEX1065	0.825	360
IE1-K11R 280 S8 Ex II 2D	37	481	735	IE1- 90.5	90.0	87.5	0.80	74	5.5	2.0	1.5	2.0	IBExU09ATEX1065	1.35	465
IE1-K11R 280 M8 Ex II 2D	45	585	735	IE1- 91.0	90.5	88.0	0.77	92.5	6.0	2.3	1.8	2.4	IBExU09ATEX1065	1.55	520
IE1-K11R 315 S8 Ex II 2D	55	710	740	IE1- 92.1	91.0	89.5	0.80	108	6.5	1.8	1.6	2.3	IBExU09ATEX1065	2.63	690
IE1-K11R 315 M8 Ex II 2D	75	968	740	IE1- 92.3	92.0	90.5	0.81	145	6.0	2.0	1.6	2.3	IBExU09ATEX1065	3.33	800
IE1-K11R 315 MX8 Ex II 2D	90	1162	740	IE1- 92.5	92.0	90.5	0.81	173	6.0	1.9	1.6	2.2	IBExU09ATEX1065	3.60	880
IE1-K11R 315 MY8 Ex II 2D	110	1420	740	IE1- 93.6	93.0	91.0	0.81	209	6.5	2.1	1.8	2.4	IBExU09ATEX1065	6.00	1100
IE1-K11R 315 L8 Ex II 2D	132	1704	740	IE1- 94.0	93.3	91.0	0.83	244	6.3	2.0	1.7	2.1	IBExU09ATEX1065	6.76	1250
IE1-K11R 315 LX8 Ex II 2D	160	2065	740	IE1- 94.2	93.5	91.0	0.79	310	7.2	2.2	1.9	2.5	IBExU09ATEX1065	8.71	1430
IE1-K12R 355 MY8 Ex II 2D	160	2054	744	IE1- 93.5	93.3	92.5	0.80	309	6.8	1.3	1.0	2.5	IBExU09ATEX1065	9.3	1700
IE1-K12R 355 M8 Ex II 2D	200	2571	743	IE1- 93.9	93.6	92.8	0.77	399	6.5	1.6	1.0	2.7	IBExU09ATEX1065	9.5	1850
IE1-K12R 355 MX8 Ex II 2D	250	3209	744	IE1- 94.1	93.9	92.8	0.78	492	6.6	1.3	1.0	2.8	IBExU09ATEX1065	13.4	2200
IE1-K12R 355 LY8 Ex II 2D	280	3594	744	IE1- 93.6	93.4	92.3	0.78	554	8.2	1.2	1.0	2.8	IBExU09ATEX1065	15.8	2400

Progressive series KPR/K10R possible upon request
 Other voltages and frequencies upon request. Changes are possible for motors which are not yet certified.



Ex II 2D Ex tb III C T125 °C Db

Three-phase motors with squirrel-cage rotor Type of explosion protection – Protection by enclosure „tb“ for operation in Zone 21 according to EN 60079-31

for rated voltage, temperature classes T1, T2 and T3
with surface cooling, duty type S1, continuous duty
thermal class F, degree of protection IP 55, 50 Hz

Motor selection data												Design point 400 V, 50 Hz	
Type	P	M _B	n _B	η _B	cosφ _B	I _B	I _k /I _B	M _A /M _B	M _S /M _B	M _K /M _B	Certificate no. IBEXU...	J	m
	kW	Nm	rpm	100 %	75 %	400 V	-	-	-	-	IBEXU...	kgm ²	kg
Synchronous speed 3000 rpm – 2-pole version													
KPER 56 G2 Ex II 2D	0.12	0.4	2830	70.3	69.6	0.77	0.32	4.5	2.1	2.3	DMT 00 ATEX E 012 X	0.00013	4.5
KPER 63 K2 Ex II 2D	0.18	0.6	2790	67.1	63.1	0.76	0.51	4.1	1.9	1.9	DMT 00 ATEX E 012 X	0.00013	4.9
KPER 63 G2 Ex II 2D	0.25	0.9	2800	68.1	65.6	0.72	0.74	4.2	2.2	2.2	DMT 00 ATEX E 012 X	0.00015	5.2
KPER 71 K2 Ex II 2D	0.37	1.3	2780	71.5	69.7	0.79	0.94	4.4	2.1	2.1	DMT 00 ATEX E 012 X	0.00025	6.7
KPER 71 G2 Ex II 2D	0.55	1.9	2775	74.3	72.7	0.81	1.32	5.1	2.3	2.1	DMT 00 ATEX E 012 X	0.00032	7.6
KPER 80 K2 Ex II 2D	0.75	2.5	2825	77.5	77.3	0.81	1.72	5.9	2.4	2.4	DMT 00 ATEX E 012 X	0.00057	10.7
KPER 80 G2 Ex II 2D	1.1	3.7	2835	77.8	77.4	0.80	2.55	6.0	2.4	2.3	DMT 00 ATEX E 012 X	0.00072	11.5
KPER 90 S2 Ex II 2D	1.5	5	2840	81.2	80.2	0.86	3.1	7.0	2.5	2.5	DMT 00 ATEX E 012 X	0.00132	16.0
KPER 90 L2 Ex II 2D	2.2	7.4	2850	82.0	81.5	0.85	4.55	7.5	2.8	2.3	DMT 00 ATEX E 012 X	0.0017	19.0
KPER 100 L2 Ex II 2D	3.0	10	2865	83.4	84.2	0.84	6.15	6.8	2.4	2.2	DMT 00 ATEX E 012 X	0.00275	25.0
KPER 112 M2 Ex II 2D	4.0	13.2	2900	85.0	86.3	0.81	8.4	7.0	2.2	2.1	DMT 00 ATEX E 012 X	0.0045	32
KPER 132 S2T Ex II 2D	5.5	18.2	2890	86.3	86.6	0.84	11	7.5	2.4	2.2	DMT 00 ATEX E 012 X	0.0055	40
K21Q 132 S2 Ex II 2D	5.5	18	2890	81.5	85.7	0.85	11.5	5.8	1.9	1.7	IBEXU 02 ATEX 1019	0.0081	50
K21Q 132 SX2 Ex II 2D	7.5	25	2900	87.0	87.0	0.86	14.5	6.6	1.8	1.3	IBEXU 02 ATEX 1019	0.0110	57
K21Q 160 M2 Ex II 2D	11.0	36	2900	88.5	88.5	0.90	20	7.0	2.2	1.8	IBEXU 02 ATEX 1019	0.0258	81
K21Q 160 MX2 Ex II 2D	15.0	49	2930	89.4	89.4	0.90	27	7.1	2.2	1.7	IBEXU 02 ATEX 1019	0.0575	118
K21Q 160 L2 Ex II 2D	18.5	61	2920	90.5	89.5	0.92	32	7.2	2.1	1.6	IBEXU 02 ATEX 1019	0.0675	134
K21Q 180 M2 Ex II 2D	22.0	72	2935	91.8	91.0	0.92	37.5	6.8	1.7	1.4	IBEXU 02 ATEX 1019	0.105	165
K21Q 200 L2 Ex II 2D	30.0	97	2940	92.8	92.0	0.92	50.5	7.3	2.0	1.6	IBEXU 02 ATEX 1019	0.128	195
K21Q 200 LX2 Ex II 2D	37.0	120	2940	93.0	92.0	0.90	64	7.0	1.8	1.3	IBEXU 02 ATEX 1019	0.193	255
K21Q 225 M2 Ex II 2D	45.0	146	2940	93.7	93.0	0.91	76	7.5	1.8	1.4	IBEXU 02 ATEX 1019	0.220	290
K21Q 250 M2 Ex II 2D	55.0	178	2955	93.7	92.5	0.91	93	7.5	2.0	1.5	IBEXU 02 ATEX 1019	0.375	360
K21Q 280 S2 Ex II 2D	75.0	241	2970	94.6	93.5	0.92	124	7.5	2.0	1.6	IBEXU 02 ATEX 1019	0.650	490
K21Q 280 M2 Ex II 2D	90.0	289	2970	94.7	94.2	0.91	151	8.5	2.2	1.8	IBEXU 02 ATEX 1019	0.675	510
K21Q 315 S2 Ex II 2D	110	353	2975	95.4	94.5	0.91	183	8.5	1.5	1.3	IBEXU 02 ATEX 1019	1.21	720
K21Q 315 M2 Ex II 2D	132	424	2975	95.4	94.5	0.91	219	8.5	2.0	1.8	IBEXU 02 ATEX 1019	1.44	800
K21Q 315 MX2 Ex II 2D	160	514	2975	96.0	95.0	0.93	259	8.5	2.0	1.6	IBEXU 02 ATEX 1019	1.76	980
K21Q 315 MY2 Ex II 2D	200	643	2970	96.0	95.2	0.92	327	8.2	2.6	2.0	IBEXU 02 ATEX 1019	2.82	1170
K21Q 315 L2 Ex II 2D	250	803	2973	96.1	95.2	0.93	404	7.3	2.1	1.4	IBEXU 02 ATEX 1019	3.66	1460
K21Q 315 LX2 Ex II 2D	315	1011	2975	96.7	95.5	0.92	511	7.4	2.4	1.4	IBEXU 02 ATEX 1019	4.43	1630
Synchronous speed 1500 rpm – 4-pole version													
KPER 56 K4 U Ex II 2D	0.06	0.4	1410	60.5	56.8	0.60	0.24	3.1	2.3	2.3	DMT 00 ATEX E 012 X	0.00019	4.3
KPER 56 G4 Ex II 2D	0.09	0.6	1375	62.0	61	0.68	0.31	3.2	1.9	1.9	DMT 00 ATEX E 012 X	0.00019	4.4
KPER 63 K4 Ex II 2D	0.12	0.8	1370	57.5	56.7	0.68	0.44	3.2	1.9	1.8	DMT 00 ATEX E 012 X	0.00019	4.8
KPER 63 G4 Ex II 2D	0.18	1.3	1360	61.0	56.5	0.66	0.65	3.3	2.0	2.0	DMT 00 ATEX E 012 X	0.00024	5.2
KPER 71 K4 Ex II 2D	0.25	1.7	1385	64.6	62.3	0.72	0.78	3.6	1.8	1.8	DMT 00 ATEX E 012 X	0.00040	6.8
KPER 71 G4 Ex II 2D	0.37	2.6	1370	67.8	66.9	0.74	1.06	3.8	2.0	2.0	DMT 00 ATEX E 012 X	0.00050	7.8
KPER 80 K4 Ex II 2D	0.55	3.8	1400	71.5	69.3	0.69	1.60	4.1	2.1	2.0	DMT 00 ATEX E 012 X	0.00087	10.6
KPER 80 G4 Ex II 2D	0.75	5.1	1400	73.5	70.8	0.70	2.10	4.6	2.2	2.1	DMT 00 ATEX E 012 X	0.00107	11.7
KPER 90 S4 Ex II 2D	1.1	7.5	1410	76.6	75.3	0.79	2.62	5.5	2.3	2.2	DMT 00 ATEX E 012 X	0.00207	15.5
KPER 90 L4 Ex II 2D	1.5	10.2	1400	78.8	77.9	0.81	3.40	5.5	2.5	2.4	DMT 00 ATEX E 012 X	0.00260	18.0
KPER 100 L4 Ex II 2D	2.2	14.9	1410	81.2	82	0.79	4.95	6.0	2.5	2.3	DMT 00 ATEX E 012 X	0.00400	23.5
KPER 100 LX4 Ex II 2D	3.0	20	1430	82.6	82.6	0.79	6.65	6.5	2.5	2.2	DMT 00 ATEX E 012 X	0.00725	30
KPER 112 M4 Ex II 2D	4.0	26.6	1435	84.2	83.6	0.78	8.80	6.9	2.6	2.5	DMT 00 ATEX E 012 X	0.00900	37
K21Q 132 S4 Ex II 2D	5.5	36	1440	85.7	85.7	0.89	10.5	6.5	1.9	1.7	IBEXU 02 ATEX 1019	0.0150	50
K21Q 132 M4 Ex II 2D	7.5	49	1450	87.0	86.0	0.84	15	6.0	2.0	1.7	IBEXU 02 ATEX 1019	0.0280	70
K21Q 160 M4 Ex II 2D	11.0	72	1450	88.4	88.0	0.85	21	6.8	2.2	1.9	IBEXU 02 ATEX 1019	0.0350	92
K21Q 160 L4 Ex II 2D	15.0	98	1465	89.4	89.0	0.86	28	7.3	2.5	2.0	IBEXU 02 ATEX 1019	0.0780	120
K21Q 180 M4 Ex II 2D	18.5	121	1460	90.0	89.5	0.86	34.5	6.8	2.5	2.0	IBEXU 02 ATEX 1019	0.0900	136
K21Q 180 L4 Ex II 2D	22.0	143	1465	90.5	90.5	0.84	42	6.5	2.0	1.8	IBEXU 02 ATEX 1019	0.138	170
K21Q 200 L4 Ex II 2D	30.0	196	1465	91.5	91.0	0.85	55.5	7.0	2.0	1.7	IBEXU 02 ATEX 1019	0.168	200
K21Q 225 S4 Ex II 2D	37.0	240	1470	92.5	91.5	0.86	67	7.0	2.0	1.7	IBEXU 02 ATEX 1019	0.275	270
K21Q 225 M4 Ex II 2D	45.0	292	1470	93.0	92.5	0.86	81	7.0	2.0	1.7	IBEXU 02 ATEX 1019	0.313	300
K21Q 250 M4 Ex II 2D	55.0	356	1475	93.5	93.0	0.86	98.5	7.0	2.2	1.7	IBEXU 02 ATEX 1019	0.525	375
K21Q 280 S4 Ex II 2D	75.0	484	1480	94.1	93.5	0.86	134	7.0	2.0	1.7	IBEXU 02 ATEX 1019	0.950	520
K21Q 280 M4 Ex II 2D	90.0	581	1480	94.6	93.5	0.86	160	7.0	2.1	1.6	IBEXU 02 ATEX 1019	1.10	580
K21Q 315 S4 Ex II 2D	110	707	1485	95.1	94.5	0.86	194	7.5	1.8	1.6	IBEXU 02 ATEX 1019	1.96	740
K21Q 315 M4 Ex II 2D	132	849	1485	95.1	94.5	0.86	233	7.0	1.8	1.5	IBEXU 02 ATEX 1019	2.27	840
K21Q 315 MX4 Ex II 2D	160	1032	1480	95.0	94.8	0.87	279	7.0	1.8	1.5	IBEXU 02 ATEX 1019	2.73	1000
K21Q 315 MY4 Ex II 2D	200	1286	1485	96.0	95.0	0.88	342	7.5	2.0	1.8	IBEXU 02 ATEX 1019	4.82	1200
K21Q 315 L4 Ex II 2D	250	1608	1485	96.1	95.0	0.90	417	8.0	2.0	1.6	IBEXU 02 ATEX 1019	5.93	1450
K21Q 315 LX4 Ex II 2D	315	2019	1490	96.5	95.5	0.88	535	8.6	1.9	1.5	IBEXU 02 ATEX 1019	6.82	1630

Other voltages and frequencies upon request. Changes are possible for motors which are not yet certified.

Three-phase motors with squirrel-cage rotor
Type of explosion protection – Protection by enclosure „tb“
for operation in Zone 21 according to EN 60079-31

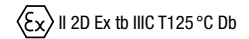

for rated voltage, temperature classes T1, T2 and T3
 with surface cooling, duty type S1, continuous duty
 thermal class F, degree of protection IP 55, 50 Hz

Motor selection data												Design point 400 V, 50 Hz		
Type	P	M _B	n	η _B	cosφ _B	I	I _k /I _B	M _k /M	M _g /M	M _k /M	Certificate no. IBEXU...	J	m	
	kW	Nm	rpm	100 %	75 %	400 V	-	-	-	-	IBEXU...	kgm ²	kg	
Synchronous speed 1000 rpm – 6-pole version														
KPER 63 K6 Ex II 2D	0.09	1	895	50.5	45.3	0.56	0.46	2.5	2.0	2.0	2.4	DMT 00 ATEX E 012 X	0.00024	4.9
KPER 63 G6 Ex II 2D	0.12	1.3	880	52.0	48	0.56	0.59	2.5	2.0	2.0	2.3	DMT 00 ATEX E 012 X	0.00027	5.7
KPER 71 K6 Ex II 2D	0.18	1.9	925	58.0	54.5	0.51	0.88	2.8	1.6	1.6	2.1	DMT 00 ATEX E 012 X	0.00045	7.4
KPER 71 G6 Ex II 2D	0.25	2.6	915	60.0	56.5	0.55	1.10	2.9	2.0	2.0	2.2	DMT 00 ATEX E 012 X	0.00060	8.3
KPER 80 K6 Ex II 2D	0.37	3.9	915	66.0	62.5	0.66	1.22	3.4	2.0	2.0	2.0	DMT 00 ATEX E 012 X	0.00130	11.0
KPER 80 G6 Ex II 2D	0.55	5.7	915	68.0	65.5	0.67	1.73	3.7	2.2	2.2	2.4	DMT 00 ATEX E 012 X	0.00175	12.5
KPER 90 S6 Ex II 2D	0.75	7.7	935	70.0	67.5	0.64	2.43	4.5	2.4	2.4	2.6	DMT 00 ATEX E 012 X	0.00325	16.0
KPER 90 L6 Ex II 2D	1.1	11.2	935	73.0	70	0.69	3.15	4.6	2.2	2.2	2.6	DMT 00 ATEX E 012 X	0.00425	19.0
KPER 100 L6 Ex II 2D	1.5	15.2	945	76.4	76.2	0.73	3.90	4.6	2.1	2.0	2.4	DMT 00 ATEX E 012 X	0.00625	24.0
KPER 112 M6 Ex II 2D	2.2	22.1	950	79.8	78.9	0.74	5.35	5.3	2.2	2.1	2.7	DMT 00 ATEX E 012 X	0.01225	33.5
K21Q 132 S6 Ex II 2D	3.0	30	955	78.5	78.5	0.82	6.7	5.7	1.8	1.6	2.7	IBEXU 02 ATEX 1019	0.0180	46
K21Q 132 M6 Ex II 2D	4.0	40	955	80.0	79.0	0.80	9	6.0	2.2	2.0	3.1	IBEXU 02 ATEX 1019	0.0230	53
K21Q 132 MX6 Ex II 2D	5.5	55	955	83.0	83.0	0.83	11.5	5.0	1.8	1.5	2.3	IBEXU 02 ATEX 1019	0.0430	70
K21Q 160 M6 Ex II 2D	7.5	75	960	85.0	84.0	0.82	15.5	5.5	2.0	1.6	2.5	IBEXU 02 ATEX 1019	0.0530	86
K21Q 160 L6 Ex II 2D	11.0	109	965	85.2	85.0	0.86	21.5	5.0	2.0	1.7	2.3	IBEXU 02 ATEX 1019	0.113	114
K21Q 180 L6 Ex II 2D	15.0	148	965	86.0	85.0	0.83	30.5	6.0	2.4	2.1	2.7	IBEXU 02 ATEX 1019	0.145	136
K21Q 200 L6 Ex II 2D	18.5	182	970	88.1	88.0	0.87	35	5.5	2.0	1.7	2.4	IBEXU 02 ATEX 1019	0.228	175
K21Q 200 LX6 Ex II 2D	22.0	217	970	88.8	88.5	0.87	41	6.2	2.2	1.8	2.6	IBEXU 02 ATEX 1019	0.268	200
K21Q 225 M6 Ex II 2D	30.0	294	973	90.4	90.0	0.89	54	6.5	2.2	1.7	2.5	IBEXU 02 ATEX 1019	0.443	284
K21Q 250 M6 Ex II 2D	37.0	362	975	91.0	90.8	0.89	66	6.5	2.2	1.7	2.3	IBEXU 02 ATEX 1019	0.825	375
K21Q 280 S6 Ex II 2D	45.0	439	980	92.0	92.0	0.87	81	6.0	2.0	1.5	2.0	IBEXU 02 ATEX 1019	1.28	465
K21Q 280 M6 Ex II 2D	55.0	536	980	92.5	92.0	0.88	97.5	6.5	2.3	1.7	2.4	IBEXU 02 ATEX 1019	1.48	575
K21Q 315 S6 Ex II 2D	75	727	985	93.7	93.0	0.87	133	7.0	2.0	1.6	2.4	IBEXU 02 ATEX 1019	2.63	690
K21Q 315 M6 Ex II 2D	90	868	990	94.4	93.5	0.88	156	7.0	2.0	1.7	2.4	IBEXU 02 ATEX 1019	3.33	800
K21Q 315 MX6 Ex II 2D	110	1061	990	94.0	93.8	0.88	192	7.5	2.2	1.7	2.6	IBEXU 02 ATEX 1019	3.60	880
K21Q 315 MY6 Ex II 2D	132	1273	990	95.0	94.7	0.88	228	7.5	2.0	1.7	2.4	IBEXU 02 ATEX 1019	6.00	1050
K21Q 315 L6 Ex II 2D	160	1551	985	95.3	95.0	0.89	272	7.5	2.3	1.9	2.4	IBEXU 02 ATEX 1019	6.67	1250
K21Q 315 LX6 Ex II 2D	180	1735	990	95.0	94.7	0.87	321	8.5	2.5	1.6	2.6	IBEXU 02 ATEX 1019	8.60	1460
Synchronous speed 750 rpm – 8-pole version														
KPER 71 K8 Ex II 2D	0.09	1.3	675	45.5	40.3	0.51	0.56	2.1	1.9	1.9	2.1	DMT 00 ATEX E 012 X	0.00050	6.6
KPER 71 G8 Ex II 2D	0.12	1.7	670	46.5	41.3	0.51	0.73	2.3	1.8	1.8	2.1	DMT 00 ATEX E 012 X	0.00060	8.1
KPER 80 K8 Ex II 2D	0.18	2.5	690	56.5	53.8	0.59	0.78	2.8	2.0	2.0	2.2	DMT 00 ATEX E 012 X	0.00130	10.5
KPER 80 G8 Ex II 2D	0.25	3.4	695	58.0	54	0.56	1.12	3.0	2.3	2.3	2.5	DMT 00 ATEX E 012 X	0.00175	12.0
KPER 90 S8 Ex II 2D	0.37	5	700	61.5	56.3	0.54	1.6	3.0	1.9	1.9	2.1	DMT 00 ATEX E 012 X	0.00300	15.0
KPER 90 L8 Ex II 2D	0.55	7.6	695	64.5	61.8	0.60	2.04	3.2	1.9	1.9	2.2	DMT 00 ATEX E 012 X	0.00375	18.0
KPER 100 L8 Ex II 2D	0.75	10.2	705	67.0	64	0.60	2.7	3.3	1.8	1.8	2.2	DMT 00 ATEX E 012 X	0.00625	23.0
KPER 100 LX8 Ex II 2D	1.1	14.9	705	73.0	72.5	0.67	3.25	4.0	2.0	2.0	2.4	DMT 00 ATEX E 012 X	0.00900	28.0
KPER 112 M8 Ex II 2D	1.5	20.3	705	75.5	75.3	0.70	4.1	4.4	2.2	2.1	2.5	DMT 00 ATEX E 012 X	0.01225	33.5
K21Q 132 S8 Ex II 2D	2.2	30	705	75.5	75.0	0.76	5.5	4.5	1.7	1.6	2.3	IBEXU 02 ATEX 1019	0.0180	46
K21Q 132 M8 Ex II 2D	3.0	41	705	78.0	78.0	0.75	7.4	4.5	1.7	1.6	2.3	IBEXU 02 ATEX 1019	0.0230	53
K21Q 160 M8 Ex II 2D	4.0	54	710	79.3	79.0	0.78	9.3	4.0	1.6	1.3	1.9	IBEXU 02 ATEX 1019	0.0430	70
K21Q 160 MX8 Ex II 2D	5.5	74	710	81.4	81.0	0.78	12.5	4.5	1.7	1.6	2.1	IBEXU 02 ATEX 1019	0.0530	86
K21Q 160 L8 Ex II 2D	7.5	99	725	83.0	83.0	0.78	16.5	4.5	1.8	1.6	2.1	IBEXU 02 ATEX 1019	0.113	114
K21Q 180 L8 Ex II 2D	11.0	146	720	85.0	84.0	0.78	24	4.5	2.0	1.7	2.1	IBEXU 02 ATEX 1019	0.145	136
K21Q 200 L8 Ex II 2D	15.0	198	725	86.5	86.0	0.79	31.5	5.0	2.0	1.7	2.3	IBEXU 02 ATEX 1019	0.228	175
K21Q 225 S8 Ex II 2D	18.5	244	725	89.2	88.0	0.83	36	5.5	2.0	1.6	2.2	IBEXU 02 ATEX 1019	0.440	265
K21Q 225 M8 Ex II 2D	22.0	290	725	89.2	89.0	0.84	42.5	5.0	1.8	1.5	2.2	IBEXU 02 ATEX 1019	0.440	265
K21Q 250 M8 Ex II 2D	30.0	392	730	90.2	90.0	0.79	61	5.5	2.2	1.8	2.2	IBEXU 02 ATEX 1019	0.825	360
K21Q 280 S8 Ex II 2D	37.0	481	735	91.0	90.5	0.80	73.5	5.5	2.0	1.5	2.0	IBEXU 02 ATEX 1019	1.35	465
K21Q 280 M8 Ex II 2D	45.0	585	735	91.5	91.0	0.77	92	6.0	2.3	1.8	2.4	IBEXU 02 ATEX 1019	1.55	520
K21Q 315 S8 Ex II 2D	55	710	740	93.1	92.0	0.80	107	6.5	1.8	1.6	2.3	IBEXU 02 ATEX 1019	2.63	690
K21Q 315 M8 Ex II 2D	75	968	740	93.3	93.0	0.81	143	6.0	2.0	1.6	2.3	IBEXU 02 ATEX 1019	3.33	800
K21Q 315 MX8 Ex II 2D	90	1161	740	93.5	93.0	0.81	172	6.0	1.9	1.6	2.2	IBEXU 02 ATEX 1019	3.60	880
K21Q 315 MY8 Ex II 2D	110	1420	740	94.6	94.0	0.81	207	6.5	2.1	1.8	2.4	IBEXU 02 ATEX 1019	6.00	1050
K21Q 315 L8 Ex II 2D	132	1704	740	95.0	94.3	0.83	242	6.3	2.0	1.7	2.1	IBEXU 02 ATEX 1019	6.76	1250
K21Q 315 LX8 Ex II 2D	160	2065	740	95.2	94.5	0.79	307	7.2	2.2	1.9	2.5	IBEXU 02 ATEX 1019	8.71	1430

Other voltages and frequencies upon request. Changes are possible for motors which are not yet certified.

Three-phase motors with squirrel-cage rotor, Premium Efficiency IE3 Type of explosion protection – Protection by enclosure „tc“ for operation in Zone 22 according to EN 60079-31

II 3D Ex tc IIIB T125 °C Dc

for rated voltage, temperature classes T1, T2 and T3
with surface cooling, duty type S1, continuous duty
thermal class F, degree of protection IP 55, 50 Hz

Motor selection data													Design point 400 V, 50 Hz	
Type	P	M _B	n _B	η _B			cos φ _B	I _B	I _R /I _B	M _R /M _B	M _S /M _B	M _K /M _B	J	m
	kW	Nm	rpm	(IEC/EN 60034-30-1)			-	400 V	-	-	-	-	kgm ²	kg
Synchronous speed 3000 rpm – 2-pole version														
IE3-KPER 90 S2 Ex II 3D	1.5	4.94	2900	IE3- 84.2	85.4	83.2	0.81	3.12	7.9	3.5	3.5	4.4	0.0017	19
IE3-KPR 90 S2 Ex II 3D	1.5	4.92	2910	IE3- 84.2	86.6	84.5	0.86	2.9	9.1	3.0	2.7	3.7	0.00275	23.5
IE3-KPR 90 LY2 Ex II 3D	2.2	7.3	2880	IE3- 85.9	85.7	83.9	0.88	4.25	8.0	2.5	2.3	2.9	0.00275	23.5
IE3-KPR 90 L2 Ex II 3D	2.2	7.23	2905	IE3- 85.9	87.7	86.0	0.89	4.05	8.6	2.7	2.3	3.7	0.00333	29
IE3-KPR 100 LY2 Ex II 3D	3	9.81	2920	IE3- 87.1	88.0	86.3	0.82	6	7.7	2.3	2.2	3.5	0.0045	31
IE3-KPR 100 L2 Ex II 3D	3	9.78	2930	IE3- 87.1	88.2	87.5	0.85	5.8	9.1	2.3	2.0	3.6	0.0055	38
IE3-KPER 112 MY2 Ex II 3D	4	13.1	2920	IE3- 88.1	87.5	86.9	0.84	7.9	8.3	2.3	2.1	3.3	0.0055	38
IE3-KPER 112 MV2 Ex II 3D	4	13	2930	IE3- 88.1	89.3	88.1	0.85	7.6	9.0	2.7	2.4	3.7	0.0068	46
IE3-KPER 112 MX2 Ex II 3D	5.5	17.96	2925	IE3- 89.2	89.4	87.7	0.8	11.1	8.3	2.6	2.5	3.8	0.0068	46
IE3-KPER 132 S2T Ex II 3D	5.5	18	2925	IE3- 89.2	89.4	87.7	0.8	11.1	8.3	2.6	2.5	3.8	0.0068	48
IE3-W41R 112 M2 Ex II 3D	4	13.0	2930	IE3- 89.2	89.2	87.9	0.87	7.4	6.9	1.5	1.2	2.9	0.011	60
IE3-W41R 132 S2 Ex II 3D	5.5	18.0	2930	IE3- 89.2	88.6	87.0	0.84	10.5	7.7	1.9	1.3	3.5	0.011	65
IE3-W41R 132 SX2 Ex II 3D	7.5	24.0	2925	IE3- 90.1	89.4	87.9	0.87	14.0	8.0	2.5	2.1	3.3	0.0168	75
IE3-W41R 160 M2 Ex II 3D	11	36.0	2950	IE3- 91.4	91.7	90.5	0.90	19.5	8.0	2.2	1.8	3.2	0.0575	125
IE3-W41R 160 MX2 Ex II 3D	15	49.0	2950	IE3- 91.9	92.0	91.3	0.91	26.0	7.9	2.2	1.7	3.1	0.0675	145
IE3-W41R 160 L2 Ex II 3D	18.5	60.0	2960	IE3- 92.4	92.5	91.4	0.90	32.0	9.2	2.6	2.1	3.6	0.078	160
IE3-W41R 180 M2C Ex II 3D	22	71	2975	IE3- 92.7	92.6	91.5	0.91	37.5	8.9	1.9	1.4	3.3	0.1717	214
IE3-W41R 200 L2 Ex II 3D	30	97	2965	IE3- 93.3	92.2	90.6	0.88	52.5	8.6	2.1	1.6	3.3	0.36	305
IE3-W41R 200 LX2C Ex II 3D	37	119	2980	IE3- 93.7	92.9	91.7	0.89	64.0	8.7	1.7	1.3	3.2	0.4757	310
IE3-W41R 225 M2 Ex II 3D	45	145	2960	IE3- 94.0	93.7	93.0	0.89	77.5	8.8	2.3	1.9	3.2	0.375	375
IE3-W41R 250 M2 Ex II 3D	55	177	2970	IE3- 94.6	94.4	93.6	0.91	92	8.9	2.2	1.9	3.2	0.65	510
IE3-W41R 280 S2 Ex II 3D	75	241	2967	IE3- 94.7	94.5	93.9	0.89	128	8.1	1.9	1.9	2.8	0.65	500
IE3-W41R 280 M2 Ex II 3D	90	289	2970	IE3- 95.0	94.5	94.0	0.90	152	8.4	2.2		3.1	0.675	545
IE3-W41R 315 S2 Ex II 3D	110	354	2970	IE3- 95.2	94.5	93.5	0.89	187	10.0	1.9	1.7	3.0	1.21	750
IE3-W41R 315 M2 Ex II 3D	132	423	2980	IE3- 95.4	95.0	94.5	0.89	224	10.0	2.0	1.8	3.0	1.44	815
IE3-W41R 315 MX2 Ex II 3D	160	513	2980	IE3- 95.7	95.7	95.0	0.9	268	8.5	2.3	1.7	2.6	2.37	1095
IE3-W41R 315 MY2 Ex II 3D	200	641	2980	IE3- 95.8	95.9	95.5	0.91	331	8.3	2.6	1.6	2.4	2.82	1200
IE3-W41R 315 L2 Ex II 3D	250	800	2985	IE3- 96.0	96.0	95.9	0.92	409	8.4	2.5	1.4	2.3	3.66	1460
IE3-W41R 315 LX2 Ex II 3D	315	1008	2985	IE3- 95.8	95.8	95.8	0.92	516	8.5	2.8	1.6	2.5	4.43	1700
IE3-W41R 355 M2G Ex II 3D	355	1136	2985	IE3- 96.0	96.0	96.0	0.92	580	7.7	1.9	1.5	3.8	4.20	2000
IE3-W42R 355 MX2G Ex II 3D	400	1278	2990	IE3- 95.8	95.8	95.3	0.91	665	8.5	1.5	1.2	2.5	5.50	2200
IE3-W42R 355 L2G Ex II 3D	500	1597	2990	IE3- 95.8	95.8	95.3	0.90	840	9.0	2.0	1.3	3.0	7.10	2445
IE3-W42R 400 M2G Ex nA IIC T3	530	1690	2990	IE3- 95.8	95.4	95.0	0.84	950	8.5	1.7	1.1	2.2	8.44	3060
IE3-W42R 400 MX2G Ex nA IIC T3	570	1820	2990	IE3- 95.8	95.8	95.3	0.90	955	8.1	2.0	1.4	2.2	9.41	3200
IE3-W42R 400 L2G Ex nA IIC T3	650	2075	2990	IE3- 96.1	96.0	95.4	0.90	1085	8.1	2.2	1.2	2.4	10.41	3400

IP 65 required for conductive dust! Ex tc IIIC T125 °C Dc
Other voltages and frequencies upon request. Changes are possible for motors which are not yet certified.

Three-phase motors with squirrel-cage rotor, Premium Efficiency IE3
Type of explosion protection – Protection by enclosure „tc“
for operation in Zone 22 according to EN 60079-31

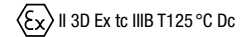

for rated voltage, temperature classes T1, T2 and T3
 with surface cooling, duty type S1, continuous duty
 thermal class F, degree of protection IP 55, 50 Hz

Motor selection data													Design point 400 V, 50 Hz	
Type	P	M _B	n _B	η _B			cosφ _B	I _B	I _A /I _B	M _A /M _B	M _S /M _B	M _K /M _B	J	m
	kW	Nm	rpm	(IEC/EN 60034-30-1)			-	400 V	-	-	-	-	kgm ²	kg
Synchronous speed 1500 rpm – 4-pole version														
IE3-KPER 63 K4 Ex II 3D	0.12	0.84	1365	IE3- 64.8	64.5	59.7	0.72	0.37	3.2	1.9	1.8	2.2	0.00024	5.2
IE3-KPR 63 G4 Ex II 3D	0.18	1.21	1415	IE3- 69.9	67.2	61.2	0.67	0.55	4.4	1.8	1.8	2.7	0.0005	7.1
IE3-KPER 71 K4 Ex II 3D	0.25	1.71	1395	IE3- 73.5	71.2	66.7	0.7	0.72	3.9	2.1	2.1	2.5	0.0005	7.8
IE3-KPR 71 K4 Ex II 3D	0.25	1.67	1430	IE3- 73.5	73.1	69.6	0.71	0.66	5.6	2.5	2.3	2.9	0.00087	9.9
IE3-KPR 71 GY4 Ex II 3D	0.37	2.48	1425	IE3- 77.3	76.8	73.0	0.69	1	4.9	2.4	2.4	3.0	0.00087	9.9
IE3-KPR 71 G4 Ex II 3D	0.37	2.47	1430	IE3- 77.3	78.2	73.1	0.69	0.98	6.2	2.8	2.6	3.2	0.00107	11
IE3-KPR 80 K4 Ex II 3D	0.55	3.67	1430	IE3- 80.8	81.0	80.1	0.8	1.25	6.0	2.4	2.3	2.7	0.00207	14.5
IE3-KPR 80 G4 Ex II 3D	0.75	4.96	1445	IE3- 82.5	82.3	79.6	0.77	1.7	7.0	3.1	3.1	3.7	0.0026	17
IE3-KPR 80 GX4 Ex II 3D	0.75	5.01	1430	IE3- 82.5	82.9	81.1	0.8	1.65	7.0	2.9	2.8	3.2	17.94	4600
IE3-KPR 90 SY4 Ex II 3D	1.1	7.3	1440	IE3- 84.1	82.6	79.7	0.76	2.5	6.7	2.8	2.7	3.7	0.004	22.5
IE3-KPR 90 S4 Ex II 3D	1.1	7.24	1450	IE3- 84.1	83.5	80.0	0.74	2.55	8.0	3.6	3.5	4.2	0.0045	28
IE3-KPR 90 L4 Ex II 3D	1.5	9.91	1445	IE3- 85.3	83.2	80.7	0.77	3.35	7.2	3.2	3.0	3.5	0.0045	28
IE3-KPR 90 LX4 Ex II 3D	1.5	9.85	1455	IE3- 85.3	84.0	80.6	0.75	3.4	9.5	4.5	3.8	4.9	0.0058	31
IE3-KPR 100 LY4 Ex II 3D	2.2	14.4	1455	IE3- 86.7	85.2	81.7	0.77	4.8	9.3	3.2	3.0	3.6	0.009	36
IE3-KPR 100 L4 Ex II 3D	2.2	14.49	1450	IE3- 86.7	87.0	85.1	0.81	4.55	8.2	2.9	2.7	3.8	0.011	45
IE3-KPR 100 LW4 Ex II 3D	2.2	14.4	1460	IE3- 86.7	86.4	84.3	0.76	4.75	8.6	3.8	3.7	4.5	0.013	50
IE3-KPR 100 LX4 Ex II 3D	3	19.7	1455	IE3- 87.7	86.3	84.5	0.77	6.5	9.0	3.3	3.1	3.9	0.011	45
IE3-KPR 100 LZ4 Ex II 3D	3	19.7	1455	IE3- 87.7	87.6	86.1	0.77	6.4	8.6	3.2	3.1	4.1	0.013	50
IE3-W41R 112 M4 Ex II 3D	4	26	1470	IE3- 89.9	89.8	88.4	0.83	7.7	9.5	2.8	2.4	4.5	0.02	65
IE3-W41R 132 S4 Ex II 3D	5.5	35	1480	IE3- 91.0	90.2	87.8	0.73	12.0	9.9	3.4	2.8	5.4	0.035	90
IE3-W41R 132 M4 Ex II 3D	7.5	49	1475	IE3- 91.3	91.3	90.1	0.83	14.5	8.6	2.4	2.0	3.9	0.043	100
IE3-W41R 160 M4 Ex II 3D	11	71	1475	IE3- 91.4	91.5	90.5	0.83	21.0	7.5	2.5	2.0	3.2	0.078	125
IE3-W41R 160 L4C Ex II 3D	15	96	1490	IE3- 92.8	92.5	91.0	0.83	28.0	10.5	2.8	2.4	3.9	0.1567	175
IE3-W41R 180 M4 Ex II 3D	18.5	120	1475	IE3- 92.7	92.9	92.0	0.84	34.5	6.9	1.9	1.7	3.0	0.168	210
IE3-W41R 180 L4 Ex II 3D	22	142	1480	IE3- 93.0	93.0	92.1	0.84	40.5	7.6	2.2	2.0	3.2	0.203	240
IE3-W41R 200 L4C Ex II 3D	30	193	1485	IE3- 93.6	92.4	92.4	0.85	54.5	7.0	1.6	1.4	2.6	0.411	327
IE3-W41R 225 S4C Ex II 3D	37	237	1490	IE3- 93.9	93.8	93.2	0.85	67.0	7.4	1.9	1.4	2.7	0.4675	367
IE3-W41R 225 M4 Ex II 3D	45	290	1482	IE3- 94.2	94.3	94.0	0.82	84	8.1	2.6	2.1	2.6	0.619	450
IE3-W41R 250 M4 Ex II 3D	55	354	1485	IE3- 94.7	94.8	94.4	0.83	101	8.1	2.1	1.8	2.5	0.95	550
IE3-W41R 280 S4 Ex II 3D	75	482	1485	IE3- 95.0	94.6	94.2	0.83	137	8.2	2.1	1.8	2.5	1.1	617
IE3-W41R 280 M4 Ex II 3D	90	578	1487	IE3- 95.2	94.7	94.0	0.83	164	9.2	2.1	1.9	2.7	1.96	785
IE3-W41R 315 S4 Ex II 3D	110	706	1487	IE3- 95.4	95.0	94.3	0.82	203	9.5	1.9	1.7	2.7	1.96	760
IE3-W41R 315 M4 Ex II 3D	132	849	1485	IE3- 95.6	95.4	95.0	0.83	240	9.0	2.2	1.9	2.7	2.27	850
IE3-W41R 315 MX4 Ex II 3D	160	1026	1490	IE3- 95.8	95.8	95.0	0.84	287	9.5	2.1	2.0	3.2	4.01	1120
IE3-W41R 315 MY4 Ex II 3D	200	1282	1490	IE3- 96.0	95.8	95.5	0.87	346	9.5	2.1	1.7	2.7	4.82	1250
IE3-W41R 315 L4 Ex II 3D	250	1602	1490	IE3- 96.2	96.2	96.0	0.87	431	9.4	2.2	1.8	2.7	5.93	1450
IE3-W41R 315 LX4 Ex II 3D	315	2019	1490	IE3- 96.0	96.0	96.0	0.87	544	9.5	2.3	1.7	2.9	6.82	1630
IE3-W41R 355 M4 Ex II 3D	355	2271	1493	IE3- 96.2	96.2	95.5	0.87	612	8.1	1.3	1.0	2.7	7.90	2150
IE3-W42R 355 MX4 Ex II 3D	400	2557	1494	IE3- 96.0	96.0	95.5	0.84	719	8.0	1.7	1.4	2.4	9.50	2400
IE3-W42R 355 L4 Ex II 3D	500	3205	1490	IE3- 96.0	96.0	95.5	0.84	899	7.2	1.6	1.2	2.2	10.00	2500
IE3-W42R 400 M4 Ex II 3D	560	3582	1493	IE3- 96.0	96.0	95.5	0.84	1006	9.0	3.4	2.9	3.9	12.60	2900
IE3-W42R 400 MX4 Ex II 3D	630	4030	1493	IE3- 96.0	96.0	95.5	0.85	1119	9.0	3.6	3.0	4.2	14.33	3100
IE3-W42R 400 L4 Ex II 3D	710	4542	1493	IE3- 96.0	96.0	95.5	0.85	1261	9.0	3.9	3.1	4.2	16.29	3450

IP 65 required for conductive dust! Ex tc IIIC T125 °C Dc
 Other voltages and frequencies upon request. Changes are possible for motors which are not yet certified.

Three-phase motors with squirrel-cage rotor, Premium Efficiency IE3 Type of explosion protection – Protection by enclosure „tc“ for operation in Zone 22 according to EN 60079-31

II 3D Ex tc III B T125 °C Dc

for rated voltage, temperature classes T1, T2 and T3
with surface cooling, duty type S1, continuous duty
thermal class F, degree of protection IP 55, 50 Hz

Motor selection data													Design point 400 V, 50 Hz	
Type	P	M _b	n _b	η _b			cos φ _b	I _b	I _r /I _b	M _r /M _b	M _s /M _b	M _k /M _b	J	m
	kW	Nm	rpm	(IEC/EN 60034-30-1)			-	400 V	-	-	-	-	kgm ²	kg
Synchronous speed 1000 rpm – 6-pole version														
	100 %	75 %	50 %											
IE3-KPR 63 G6 Ex II 3D	0.12	1.23	930	IE3- 57.7	60.0	54.0	0.56	0.5	2.8	1.9	1.8	2.1	0.00045	6.7
IE3-KPER 71 KY6 Ex II 3D	0.18	1.89	910	IE3- 63.9	62.0	56.5	0.55	0.75	2.9	1.7	1.7	2.1	0.0006	8.3
IE3-KPR 71 K6 Ex II 3D	0.18	1.85	930	IE3- 63.9	62.9	57.5	0.68	0.57	3.4	2.0	2.0	2.2	0.0013	11
IE3-KPR 71 GY6 Ex II 3D	0.25	2.54	940	IE3- 68.6	65.3	58.5	0.63	0.84	4.0	2.2	2.2	2.9	0.0013	10
IE3-KPR 71 G6 Ex II 3D	0.25	2.55	935	IE3- 68.6	66.9	62.2	0.67	0.75	3.9	2.3	2.3	2.5	0.00175	12.5
IE3-KPR 80 K6 Ex II 3D	0.37	3.72	950	IE3- 73.5	72.9	69.2	0.7	1.03	4.0	1.9	1.9	2.4	0.00325	15
IE3-KPR 80 G6 Ex II 3D	0.55	5.53	950	IE3- 77.2	75.9	72.4	0.69	1.5	4.1	2.1	2.1	2.5	0.00425	18
IE3-KPR 90 SY6 Ex II 3D	0.75	7.5	955	IE3- 78.9	78.3	75.1	0.71	1.95	4.9	2.4	2.3	2.6	0.00625	24
IE3-KPR 90 S6 Ex II 3D	0.75	7.54	950	IE3- 78.9	79.7	77.5	0.73	1.87	5.3	2.4	2.2	2.9	0.0072	30
IE3-KPR 90 L6 Ex II 3D	1.1	11	955	IE3- 81.0	81.0	78.5	0.71	2.75	5.4	2.5	2.4	2.8	0.0072	30
IE3-KPR 100 LX6 Ex II 3D	1.5	15	955	IE3- 82.5	83.5	81.5	0.76	3.45	5.9	2.3	2.2	2.8	0.0139	36
IE3-KPER 112 MV6 Ex II 3D	2.2	22	955	IE3- 84.3	83.6	80.9	0.74	5.15	5.7	2.4	2.3	2.9	0.0155	48
IE3-KPER 112 MZ6 Ex II 3D	2.2	21.88	960	IE3- 84.3	84.0	81.5	0.75	5	6.9	3.0	3.0	3.8	0.018	50
IE3-W41R 132 S6 Ex II 3D	3	30.0	965	IE3- 86.3	86.7	85.6	0.82	6.1	6.2	2.0	1.3	3.1	0.029	70
IE3-W41R 132 M6 Ex II 3D	4	40.0	965	IE3- 86.8	87.0	86.0	0.80	8.3	4.8	1.7	1.4	2.4	0.043	75
IE3-W41R 132 MX6 Ex II 3D	5.5	54.0	970	IE3- 88.6	88.6	87.2	0.80	11.0	6.0	2.1	1.7	3.0	0.053	105
IE3-W41R 160 M6 Ex II 3D	7.5	73.0	980	IE3- 90.2	90.0	88.3	0.83	14.5	6.4	2.4	2.0	3.0	0.145	145
IE3-W41R 160 L6C Ex II 3D	11	107.0	985	IE3- 91.4	91.2	89.8	0.85	20.5	6.8	2.2	2	2.8	0.166	168
IE3-W41R 180 L6C Ex II 3D	15	145.0	985	IE3- 91.2	91.3	90.2	0.87	27.5	6.8	2	1.7	2.7	0.3396	214
IE3-W41R 200 L6 Ex II 3D	18.5	180.0	980	IE3- 91.8	91.7	90.5	0.87	33.5	7.2	2.3	2	3	0.514	310
IE3-W41R 200 LX6C Ex II 3D	22	213.0	985	IE3- 92.2	91.5	90.0	0.87	39.5	7.6	2.1	1.7	2.9	0.6476	321
IE3-W41R 225 M6 Ex II 3D	30	291	984	IE3- 92.9	92.2	91.0	0.84	55.5	7.2	2.7	2.2	2.9	0.92	400
IE3-W41R 250 M6 Ex II 3D	37	359	985	IE3- 93.3	93.2	92.3	0.86	66.5	7.1	2.8	2.0	2.7	1.48	545
IE3-W41R 280 S6 Ex II 3D	45	434	990	IE3- 93.7	93.5	91.5	0.86	80.5	8.5	2.1	1.8	2.8	2.63	695
IE3-W41R 280 M6 Ex II 3D	55	531	990	IE3- 94.2	94.1	93.1	0.85	99	9.0	2.2	1.9	3.1	3.33	815
IE3-W41R 315 S6 Ex II 3D	75	723	990	IE3- 94.6	94.0	93.5	0.86	133	8.2	1.8	1.4	2.3	5.55	1060
IE3-W41R 315 M6 Ex II 3D	90	868	990	IE3- 94.9	94.0	93.0	0.83	165	8.5	2.2	1.7	2.8	6	1100
IE3-W41R 315 MX6 Ex II 3D	110	1.061	990	IE3- 95.1	95.0	94.5	0.86	194	8.5	2.5	1.7	2.7	6.67	1210
IE3-W41R 315 L6 Ex II 3D	132	1.267	995	IE3- 95.4	95.0	94.5	0.87	230	9.0	2.8	2.0	3.2	8.6	1550
IE3-W41R 355 M6 Ex II 3D	160	1.536	995	IE3- 95.6	95.0	94.6	0.82	295	8.0	2.1	0.0	2.7	8.2	1850
IE3-W42R 355 MX6 Ex II 3D	200	1919	995	IE3- 95.8	95.2	95.0	0.83	363	8.0	1.8	1.3	2.5	12.10	2200
IE3-W42R 355 L6 Ex II 3D	250	2402	994	IE3- 95.8	95.5	95.0	0.81	468	7.0	1.8	1.3	2.3	14.00	2400
IE3-W42R 355 LX6 Ex II 3D	315	3032	992	IE3- 95.8	95.5	95.3	0.86	554	7.4	2.5	2.0	2.7	14.00	2400
IE3-W42R 400 MY6 Ex II 3D	355	3407	995	IE3- 95.8	95.5	94.5	0.85	632	8.0	2.0	1.6	2.6	16.54	2900
IE3-W42R 400 M6 Ex II 3D	400	3847	993	IE3- 95.8	95.5	94.5	0.87	696	7.0	1.8	1.5	2.3	16.54	2900
IE3-W42R 400 MX6 Ex II 3D	450	4327	993	IE3- 95.8	95.7	94.6	0.83	821	7.3	1.8	1.5	2.1	18.44	3100
IE3-W42R 400 L6 Ex II 3D	500	4808	993	IE3- 95.8	95.6	94.5	0.83	911	7.5	1.9	1.7	2.2	20.63	3200

IP 65 required for conductive dust! Ex tc III C T125 °C Dc
Other voltages and frequencies upon request. Changes are possible for motors which are not yet certified.

Three-phase motors with squirrel-cage rotor, Premium Efficiency IE3
Type of explosion protection – Protection by enclosure „tc“
for operation in Zone 22 according to EN 60079-31

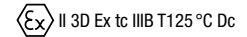

for rated voltage, temperature classes T1, T2 and T3
 with surface cooling, duty type S1, continuous duty
 thermal class F, degree of protection IP 55, 50 Hz

Motor selection data												Design point 400 V, 50 Hz			
Type	P	M _B	n _B	η _B			cos φ _B	I _B	I _A /I _B	M _A /M _B	M _S /M _B	M _R /M _B	J	m	
	kW	Nm	rpm	(IEC/EN 60034-30-1)			-	400 V	-	-	-	-	kgm ²	kg	
Synchronous speed 750 rpm – 8-pole version															
	100 %	75 %	50 %												
IE3-KPR 71 G8 Ex II 3D	0.12	1.67	685	IE3- 50.7	48.8	43.0	0.64	0.48	2.6	1.7	1.7	2.0	0.0013	9.9	
IE3-KPER 80 K8 Ex II 3D	0.18	2.53	680	IE3- 58.7	56.3	49.8	0.61	0.73	2.6	1.6	1.6	2.0	0.00175	12	
IE3-KPR 80 G8 Ex II 3D	0.25	3.39	705	IE3- 64.1	64.3	58.4	0.59	0.93	3.0	1.4	1.4	2.1	0.003	14	
IE3-KPER 90 SY8 Ex II 3D	0.37	5.01	705	IE3- 69.3	67.0	61.2	0.56	1.39	3.1	1.6	1.6	2.2	0.00375	18.5	
IE3-KPR 90 S8 Ex II 3D	0.37	4.98	710	IE3- 69.3	69.0	64.4	0.63	1.2	3.6	2.1	2.1	2.3	0.00625	25	
IE3-KPR 90 L8 Ex II 3D	0.55	7.5	700	IE3- 73.0	70.6	66.3	0.64	1.72	3.6	1.8	1.8	2.3	0.0072	26	
IE3-KPR 100 LY8 Ex II 3D	0.75	10.1	710	IE3- 75.0	74.1	70.0	0.64	2.21	4.2	2.0	2.0	2.7	0.009	28	
IE3-KPR 100 L8 Ex II 3D	0.75	10	715	IE3- 75.0	75.9	71.3	0.63	2.25	4.4	2.5	2.5	2.8	0.0123	33.5	
IE3-KPR 100 LW8 Ex II 3D	1.1		***)	IE3- 77.7											
IE3-KPR 100 LX8 Ex II 3D	1.1	14.8	710	IE3- 77.7	77.5	73.7	0.63	3.2	4.2	1.9	1.8	2.5	0.0139	36	
IE3-KPER 112 M8 Ex II 3D	1.5	20.46	700	IE3- 79.7	78.7	76.0	0.65	4.25	3.8	1.6	1.5	2.1	0.0155	48	
IE3-KPER 112 MZ8 Ex II 3D	1.5	20.3	705	IE3- 79.7	78.8	75.8	0.66	4.15	4.7	2.7	2.7	3.2	0.018	50	
IE3-W41R 132 S8 Ex II 3D	2.2	29	725	IE3- 84.4	84.5	82.4	0.7	5.4	4.1	1.6	1.5	2.3	0.043	80	
IE3-W41R 132 M8 Ex II 3D	3	40	720	IE3- 83.5	83.5	81.4	0.72	7	3.9	1.6	1.4	2.1	0.043	74	
IE3-W41R 160 M8 Ex II 3D	4	52	735	IE3- 87	86.7	83.8	0.71	9.4	5.4	2.5	2.2	2.9	0.113	119	
IE3-W41R 160 MX8 Ex II 3D	5.5	72	730	IE3- 87.5	87.5	85.6	0.73	12.5	4.7	1.9	1.7	2.5	0.145	143	
IE3-W41R 160 L8 Ex II 3D	7.5	98	733	IE3- 87.9	87.6	85.6	0.73	17	5.1	2.1	1.8	2.7	0.166	155	
IE3-W41R 180 L8 Ex II 3D	11	145	725	IE3- 89.3	89	87.1	0.75	23.5	5.4	2.1	1.9	2.8	0.228	175	
IE3-W41R 200 L8 Ex II 3D	15	196	730	IE3- 89.6	90	89	0.80	30	5.3	1.8	1.7	2.5	0.324	235	
IE3-W41R 225 S8 Ex II 3D	18.5	240	735	IE3- 90.1											
IE3-W41R 225 M8 Ex II 3D	22	286	735	IE3- 91.5	91.6	90.6	0.79	44	5.7	2.3	2	2.5	0.825	360	
IE3-W41R 250 M8 Ex II 3D	30	391	732	IE3- 91.3	91.9	91.4	0.81	58.5	5.4	2	1.8	2.3	0.92	420	
IE3-W41R 280 S8 Ex II 3D	37	479	738	IE3- 92	92	90.8	0.78	74.5	5.9	2.3	1.8	2.4	1.55	555	
IE3-W41R 280 M8 Ex II 3D	45	581	740	IE3- 93	93	92.4	0.78	89.5	6.5	1.7	1.5	2.4	2.63	700	
IE3-W41R 315 S8 Ex II 3D	55	707	743	IE3- 93.3	93.3	92.4	0.78	109	7.0	1.9	1.7	2.5	3.33	805	
IE3-W41R 315 M8 Ex II 3D	75	965	742	IE3- 93.8	94.2	93.8	0.81	142	7.0	1.9	1.7	2.3	5.55	1120	
IE3-W41R 315 MX8 Ex II 3D	90	1157	743	IE3- 94.3	94.4	93.6	0.8	172	7.9	2.4	2.0	2.7	6	1185	
IE3-W41R 315 MY8 Ex II 3D	110	1419	740	IE3- 93.8	94.0	93.8	0.82	206	6.5	1.9	1.5	2.1	6.76	1250	
IE3-W41R 315 L8 Ex II 3D	132	1703	740	IE3- 94.2	94.2	93.5	0.8	253	8.0	2.4	1.9	2.7	8.71	1450	
IE3-W41R 355 MY8 Ex II 3D	160	2051	745	IE3- 94.3	94.3	94.0	0.82	299	6.6	1.2	1.0	2.6	9.3	1700	
IE3-W41R 355 M8 Ex II 3D	200	2564	745	IE3- 94.7	94.9	94.2	0.81	376	7.0	1.0	1.0	2.7	9.5	1890	
IE3-W41R 355 MX8 Ex II 3D	230	2948	745	IE3- 95.2	95.2	95.0	0.83	420	7.0	1.2	1.0	2.6	13.40	2200	
IE3-W41R 355 L8 Ex II 3D	250	3205	745	IE3- 94.8	94.1	91.5	0.78	488						15.80	2400
IE3-W42R 355 MX8 Ex II 3D	160	2054	744	IE3- 95.4	95.0	94.0	0.8	303	6.8	1.3	1.0	2.5	13.4	2200	
IE3-W42R 355 L8 Ex II 3D	200	2570	743	IE3- 95.6	95.5	94.0	0.77	393	6.5	1.6	1.0	2.7	15.8	2400	
IE3-W42R 355 LX8 Ex II 3D	250	3213	743	IE3- 95.6	95.4	93.8	0.78	487	6.4	2.5	1.9	2.5	15.8	2400	
IE3-W42R 400 MY8 Ex II 3D	315	4048	743	IE3- 95.6	95.5	94.5	0.78	611	6.4	2.5	1.9	2.5	17.94	3000	
IE3-W42R 400 M8 Ex II 3D	355	4550	745	IE3- 95.6	95.5	94.5	0.76	708	6.6	1.9	1.7	2.3	17.94	3000	
IE3-W42R 400 MX8 Ex II 3D	400	5134	744	IE3- 95.6	95.6	94.6	0.73	831	6.1	1.8	1.7	1.9	19.99	3150	
IE3-W42R 400 L8 Ex II 3D	450	5776	744	IE3- 95.6	95.6	94.6	0.72	947	6.4	2.0	1.7	2.0	22.34	3300	

IP 65 required for conductive dust! Ex tc III C T125 °C Dc
 Other voltages and frequencies upon request. Changes are possible for motors which are not yet certified.
 ***) upon request

Three-phase motors with squirrel-cage rotor, High Efficiency IE2 Type of explosion protection – Protection by enclosure „tc“ for operation in Zone 22 according to EN 60079-31

II 3D Ex tc IIIB T125 °C Dc

for rated voltage, temperature classes T1, T2 and T3
with surface cooling, duty type S1, continuous duty
thermal class F, degree of protection IP 55, 50 Hz

Motor selection data												Design point 400 V, 50 Hz		
Type	P	M _B	n _B	η _B			cos φ _B	I _B	I _A /I _B	M _A /M _B	M _S /M _B	M _K /M _B	J	m
	kW	Nm	rpm	(IEC/EN 60034-30-1)			-	400 V	-	-	-	-	kgm ²	kg
Synchronous speed 3000 rpm – 2-pole version														
IE2-KPR 80 K2 Ex II 3D	0.75	2.49	2880	IE2- 77.4	83.6	81.6	0.88	1.48	7.7	2.2	2.1	2.7	0.00132	15
IE2-KPR 80 G2 Ex II 3D	1.1	3.64	2885	IE2- 79.6	82.1	81.2	0.89	2.15	7.8	2.5	2.3	2.8	0.0017	18
IE2-KPR 90 S2 Ex II 3D	1.5	4.92	2910	IE2- 81.3	85.5	82.9	0.87	2.9	9.0	2.8	2.4	3.4	0.00275	23.5
IE2-KPR 90 L2 Ex II 3D	2.2	7.29	2880	IE2- 83.2	85.7	83.9	0.88	4.25	8.0	2.5	2.3	2.9	0.00275	23.5
IE2-KPR 100 L2 Ex II 3D	3	9.78	2930	IE2- 84.6	86.2	83.5	0.76	6.55	8.5	2.6	2.4	3.8	0.0045	31
IE2-KPER 112 M2 Ex II 3D	4	13.2	2900	IE2- 85.8	86.3	***)	0.81	8.4	7.0	2.2	2.1	2.9	0.0045	32
IE2-KPER 112 MX2 Ex II 3D	4	13.08	2920	IE2- 85.8	86.4	85.8	0.84	7.9	8.3	2.3	2.1	3.3	0.0055	38
IE2-KPER 112 ML2 Ex II 3D	5.5	18.2	2890	IE2- 85.9	86.6	***)	0.84	11	7.5	2.4	2.2	3.0	0.0055	38
IE2-KPER 112 MV2 Ex II 3D	5.5	18.11	2900	IE2- 87.0	88.7	88.8	0.88	10.3	7.8	2.0	1.9	2.7	0.0068	46
IE2-KPER 132 SY2T Ex II 3D	5.5	18.2	2890	IE2- 87.0	86.6	***)	0.84	11	7.5	2.4	2.2	3.0	0.0055	40
IE2-KPER 132 S2T Ex II 3D	5.5	18.11	2900	IE2- 87.0	88.7	88.8	0.88	10.3	7.8	2.0	1.9	2.7	0.0068	48
IE2-KPER 112 MW2 Ex II 3D	7.5	24.9	2880	IE2- 88.1	88.0	***)	0.84	14.8	6.3	1.5	1.2	2.6	0.0068	46
IE2-KPER 132 SX2T Ex II 3D	7.5	24.9	2880	IE2- 88.1	88.0	***)	0.84	14.8	6.3	1.5	1.2	2.6	0.0068	48
IE2-WE1R 132 S2 Ex II 3D	5.5	18.0	2915	IE2- 88.7	88.7	87.8	0.85	10.5	6.8	1.9	1.5	3.0	0.0110	57
IE2-WE1R 132 SX2 Ex II 3D	7.5	24.5	2925	IE2- 88.8	89.2	88.3	0.91	13.5	6.7	2.1	1.6	2.9	0.0168	75
IE2-WE1R 160 M2 Ex II 3D	11.0	35.6	2950	IE2- 90.3	90.3	89.1	0.90	19.5	7.7	2.3	1.7	3.1	0.0258	125
IE2-WE1R 160 MX2 Ex II 3D	15.0	48.7	2940	IE2- 90.7	90.5	89.1	0.92	26	6.7	1.8	1.4	2.6	0.0675	140
IE2-WE1R 160 L2 Ex II 3D	18.5	60.2	2935	IE2- 91.0	91.4	91.4	0.91	32	7.2	2.0	1.5	2.8	0.0675	140
IE2-WE1R 180 M2 Ex II 3D	22	72	2935	IE2- 91.3	90.6	86.4	0.90	38.5	6.2	1.4	1.1	2.4	0.105	173
IE2-WE1R 200 L2 Ex II 3D	30	97	2945	IE2- 92.0	91.3	90.5	0.91	52	6.9	1.7	1.3	2.6	0.128	210
IE2-WE1R 200 LX2 Ex II 3D	37	120	2940	IE2- 92.5	92.3	91.6	0.92	63	7.4	1.9	1.4	2.9	0.154	233
IE2-WE2R 200 LX2 Ex II 3D	37	120	2940	IE2- 92.5	92.3	91.6	0.92	63	7.4	1.9	1.4	2.9	0.154	233
IE2-WE1R 225 M2 Ex II 3D	45	146	2950	IE2- 92.9	92.2	91.2	0.87	80.5	6.9	1.7	1.1	2.7	0.220	295
IE2-WE1R 250 M2 Ex II 3D	55	178	2955	IE2- 93.5	93.7	93.2	0.89	95.5	8.2	2.3	1.9	2.8	0.375	385
IE2-WE1R 280 S2 Ex II 3D	75	241	2970	IE2- 94.1	94.0	91.5	0.90	128	7.9	2.1	1.7	3.0	0.65	500
IE2-WE1R 280 M2 Ex II 3D	90	289	2970	IE2- 94.4	94.1	91.9	0.91	151	7.7	2.0	1.7	2.8	0.68	550
IE2-W21R 315 S2 Ex II 3D	110	353	2975	IE2- 94.5	94.3	93.3	0.89	189	8.0	1.3	1.2	2.4	1.21	730
IE2-W21R 315 M2 Ex II 3D	132	424	2975	IE2- 95.0	94.8	94.5	0.89	225	9.2	1.4	1.2	2.4	1.44	820
IE2-W21R 315 MX2 Ex II 3D	160	514	2973	IE2- 94.8	94.8	94.8	0.89	274	8.2	1.3	1.3	2.4	1.76	955
IE2-W21R 315 MY2 Ex II 3D	200	640	2983	IE2- 95.4	95.0	94.3	0.88	344	9.4	2.8	2.0	3.0	2.82	1200
IE2-W21R 315 L2 Ex II 3D	250	800	2984	IE2- 95.4	95.4	95.4	0.92	411	9.0	2.3	1.2	2.3	3.66	1450
IE2-W21R 315 LX2 Ex II 3D	315	1008	2985	IE2- 95.4	95.4	95.0	0.92	518	8.5	2.8	1.6	2.5	4.43	1700
IE2-W22R 355 M2G Ex II 3D	355	1136	2985	IE2- 95.5	95.5	95.5	0.92	583	7.7	1.3	1.0	2.6	4.20	2000
IE2-W22R 355 MX2G Ex II 3D	400	1278	2990	IE2- 95.5	95.5	95.5	0.91	664	9.4	1.8	1.0	3.0	4.50	2200
IE2-W22R 355 L2G Ex II 3D	450	1440	2985	IE2- 95.5	95.5	95.5	0.92	739	7.0	1.3	0.9	2.4	7.10	2400

IP 65 required for conductive dust! Ex tc IIIC T125 °C Dc
Other voltages and frequencies upon request. Changes are possible for motors which are not yet certified.
***) upon request

Three-phase motors with squirrel-cage rotor, High Efficiency IE2
Type of explosion protection – Protection by enclosure „tc“
for operation in Zone 22 according to EN 60079-31

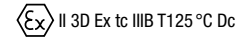

for rated voltage, temperature classes T1, T2 and T3
 with surface cooling, duty type S1, continuous duty
 thermal class F, degree of protection IP 55, 50 Hz

Motor selection data													Design point 400 V, 50 Hz	
Type	P	M _B	n _B	η _B			cosφ _B	I _B	I _N /I _B	M _N /M _B	M _S /M _B	M _R /M _B	J	m
	kW	Nm	rpm	(IEC/EN 60034-30-1)			-	400 V	-	-	-	-	kgm ²	kg
Synchronous speed 1500 rpm – 4-pole version														
100 %	75 %	50 %												
IE2-KPR 80 GY4 Ex II 3D	0.75	5.01	1430	IE2- 79.6	78.0	74.7	0.8	1.73	5.7	2.2	2.2	3.1	0.00207	14.5
IE2-KPR 80 G4 Ex II 3D	0.75	5.01	1430	IE2- 79.6	81.4	79.6	0.81	1.65	7.0	2.9	2.8	3.2	0.0026	17
IE2-KPR 90 S4 Ex II 3D	1.1	7.32	1435	IE2- 81.4	82.3	80.4	0.8	2.42	6.8	2.4	2.2	2.9	0.004	23
IE2-KPR 90 LW4 Ex II 3D	1.5	9.95	1440	IE2- 82.8	83.8	81.4	0.76	3.4	6.5	2.7	2.7	3.6	0.004	23
IE2-KPR 90 L4 Ex II 3D	1.5	9.91	1445	IE2- 82.8	83.2	80.7	0.77	3.35	7.2	3.2	3.0	3.5	0.0045	28
IE2-KPR 100 S4 Ex II 3D	2.2	14.5	1445	IE2- 84.3	84.9	82.7	0.79	4.67	7.3	2.7	2.5	3.1	0.00725	30
IE2-KPR 100 L4 Ex II 3D	2.2	14.4	1455	IE2- 84.3	85.2	81.7	0.77	4.8	9.3	3.2	3.0	3.6	0.009	36
IE2-KPR 100 LW4 Ex II 3D	3	19.8	1445	IE2- 85.5	85.8	83.6	0.79	6.33	7.8	3.0	2.9	3.6	0.009	36
IE2-KPR 100 LX4 Ex II 3D	3	19.7	1455	IE2- 85.5	86.3	84.5	0.77	6.5	9.0	3.3	3.1	3.9	0.011	45
IE2-KPER 112 MZ4 Ex II 3D	4	26.4	1445	IE2- 86.6	87.0	85.0	0.8	8.3	8.2	2.8	2.6	3.6	0.013	50
IE2-WE1R 112 M4 Ex II 3D	4.0	26.2	1460	IE2- 86.6	88.0	86.9	0.86	7.6	8.3	2.6	2.3	3.9	0.017	56
IE2-WE1R 132 S4 Ex II 3D	5.5	35.7	1470	IE2- 89.8	89.9	88.4	0.87	10	7.4	2.3	1.9	3.4	0.035	87
IE2-WE2R 132 S4 Ex II 3D	5.5	36.2	1450	IE2- 88.4	89.3	89.0	0.87	10.5	7.7	2.3	1.8	3.5	0.020	64
IE2-WE1R 132 M4 Ex II 3D	7.5	48.7	1470	IE2- 89.9	90.0	88.5	0.82	14.5	8.5	2.6	2.1	4.0	0.035	88
IE2-WE1R 160 M4 Ex II 3D	11.0	71	1475	IE2- 90.6	90.3	88.5	0.82	21.5	8.1	3.1	2.4	3.4	0.078	122
IE2-WE2R 160 M4 Ex II 3D	11	71.5	1470	IE2- 90.3	90.3	88.5	0.78	22.5	7.8	2.4	2.1	3.9	0.043	105
IE2-WE1R 160 L4 Ex II 3D	15.0	97	1470	IE2- 90.6	90.9	90.5	0.87	27.5	8.3	2.7	2.2	3.2	0.115	160
IE2-WE2R 160 L4 Ex II 3D	15	97	1480	IE2- 92.0	92.0	90.6	0.84	28	9.1	3.0	2.5	3.9	0.115	161
IE2-WE1R 180 M4 Ex II 3D	18.5	120	1475	IE2- 91.5	91.5	90.4	0.86	34	6.8	1.8	1.5	2.7	0.168	207
IE2-WE2R 180 M4 Ex II 3D	18.5	120	1470	IE2- 91.2	90.6	89.3	0.78	37.5	6.4	2.0	1.6	2.8	0.138	176
IE2-WE1R 180 L4 Ex II 3D	22	142	1475	IE2- 91.6	91.4	89.9	0.83	42	7.3	2.1	1.7	3.0	0.168	215
IE2-WE1R 200 L4 Ex II 3D	30	194	1480	IE2- 92.3	91.3	88.2	0.80	58.5	7.3	2.1	1.7	2.9	0.275	277
IE2-WE1R 225 S4 Ex II 3D	37	240	1475	IE2- 92.7	91.8	90.7	0.84	68.5	7.4	2.2	1.7	2.7	0.313	313
IE2-WE1R 225 M4 Ex II 3D	45	290	1483	IE2- 93.1	93.0	91.1	0.84	83	7.9	2.3	1.9	2.4	0.525	390
IE2-WE2R 225 M4 Ex II 3D	45	291	1475	IE2- 93.1	92.9	92.1	0.80	87	7.6	2.6	1.9	3.1	0.356	346
IE2-WE1R 250 M4 Ex II 3D	55	354	1485	IE2- 94.0	94.1	92.5	0.84	101	8.0	2.0	1.7	2.3	0.95	535
IE2-WE2R 250 M4 Ex II 3D	55	356	1477	IE2- 93.9	93.8	93.7	0.82	103	7.5	2.4	1.9	2.4	0.62	435
IE2-WE1R 280 S4 Ex II 3D	75	482	1485	IE2- 94.2	94.4	92.1	0.84	137	7.2	1.8	1.6	2.1	0.95	550
IE2-WE1R 280 M4 Ex II 3D	90	580	1483	IE2- 94.3	94.5	94.0	0.84	164	7.6	1.8	1.6	2.3	1.10	610
IE2-W21R 315 S4 Ex II 3D	110	707	1485	IE2- 94.8	94.8	94.0	0.82	204	8.5	1.8	1.5	2.7	1.96	760
IE2-W21R 315 M4 Ex II 3D	132	849	1484	IE2- 95.0	95.0	94.5	0.83	242	8.2	1.8	1.6	2.3	2.27	850
IE2-W21R 315 MX4 Ex II 3D	160	1031	1482	IE2- 95.0	95.0	94.5	0.84	289	7.4	1.6	1.4	2.2	2.73	975
IE2-W21R 315 MY4 Ex II 3D	200	1282	1490	IE2- 95.1	95.1	94.5	0.87	349	8.5	1.8	1.6	2.5	4.82	1270
IE2-W21R 315 L4 Ex II 3D	250	1602	1490	IE2- 95.4	95.4	95.3	0.88	430	9.0	2.2	1.5	2.7	5.93	1450
IE2-W21R 315 LX4 Ex II 3D	315	2019	1490	IE2- 95.4	95.4	95.0	0.88	542	9.0	2.4	1.6	2.6	6.82	1630
IE2-W22R 355 M4 Ex II 3D	355	2271	1493	IE2- 95.5	95.5	95.0	0.87	617	8.0	1.3	1.0	2.7	7.90	2150
IE2-W22R 355 MX4 Ex II 3D	400	2557	1494	IE2- 95.5	95.5	95.5	0.88	687	8.5	1.3	1.0	3.0	9.50	2400
IE2-W22R 355 L4 Ex II 3D	450	2873	1496	IE2- 95.5	95.5	95.5	0.86	790	8.5	1.4	0.8	2.9	10.00	2500

IP 65 required for conductive dust! Ex tc IIIC T125 °C Dc
 Other voltages and frequencies upon request. Changes are possible for motors which are not yet certified.

Three-phase motors with squirrel-cage rotor, High Efficiency IE2 Type of explosion protection – Protection by enclosure „tc“ for operation in Zone 22 according to EN 60079-31

Ex II 3D Ex tc IIIB T125 °C Dc

for rated voltage, temperature classes T1, T2 and T3
with surface cooling, duty type S1, continuous duty
thermal class F, degree of protection IP 55, 50 Hz

Motor selection data													Design point 400 V, 50 Hz	
Type	P	M _B	n _B	η _B			cosφ _B	I _B	I _A /I _B	M _A /M _B	M _S /M _B	M _V /M _B	J	m
	kW	Nm	rpm	(IEC/EN 60034-30-1)			-	400 V	-	-	-	-	kgm ²	kg
Synchronous speed 1000 rpm – 6-pole version														
IE2-KPR 90 S6 Ex II 3D	0.75	7.5	955	IE2- 75.9	78.3	75.1	0.71	1.95	4.9	2.4	2.3	2.6	0.00625	24
IE2-KPR 90 LW6 Ex II 3D	1.1	11	955	IE2- 78.1	78.0	75.1	0.69	2.95	4.7	2.5	2.4	2.8	0.00625	24
IE2-KPR 90 L6 Ex II 3D	1.1	11	955	IE2- 78.1	82.0	79.3	0.71	2.75	5.4	2.5	2.4	2.8	0.0072	30
IE2-KPR 100 LW6 Ex II 3D	1.1	10.94	960	IE2- 78.1	***	***	0.76	2.5	6.5	2.8	2.7	3.4	0.0139	36
IE2-KPR 100 LX6 Ex II 3D	1.5	15	955	IE2- 79.8	83.5	81.5	0.76	3.45	5.9	2.3	2.2	2.8	0.0139	36
IE2-KPER 112 MX6 Ex II 3D	2.2	21.89	960	IE2- 81.8	***	***	0.65	5.9	6.4	3.0	2.9	3.7	***	37
IE2-KPER 112 MV6 Ex II 3D	2.2	22	955	IE2- 81.8	82.5	79.8	0.75	5.15	5.7	2.4	2.3	2.9	0.0155	48
IE2-KPER 112 MZ6 ExnA IIC T3 Gc	3	30	955	IE2- 83.3	83.1	80.5	0.75	6.85	6.5	2.8	2.7	3.5	0.043	50
IE2-KPER 132 SX6T Ex II 3D	3	30	955	IE2- 83.3	83.1	80.5	0.73	7.1	7.0	3.2	3.1	4.0	0.0165	52
IE2-W21R 132 S6 Ex II 3D	3.0	29.8	963	IE2- 84.9	85.2	83.9	0.80	6.4	6.0	2.0	1.3	3.0	0.023	55
IE2-W21R 132 M6 Ex II 3D	4.0	39.6	965	IE2- 85.5	85.5	83.8	0.79	8.5	5.1	1.8	1.6	2.4	0.043	76
IE2-WE2R 132 M6 Ex II 3D	4	40	955	IE2- 85.1	86.0	85.2	0.82	8.3	5.7	2.1	2.0	2.9	0.029	66
IE2-W21R 132 MX6 Ex II 3D	5.5	54	970	IE2- 86.1	85.5	82.4	0.77	12	5.7	2.2	1.7	2.7	0.053	85
IE2-W21R 160 M6 Ex II 3D	7.5	73	975	IE2- 87.4	88.1	86.0	0.81	15.5	6.3	2.5	2.1	2.9	0.113	118
IE2-WE2R 160 M6 Ex II 3D	7.5	74	970	IE2- 87.5	87.6	85.9	0.79	15.5	5.9	2.1	1.8	2.9	0.053	103
IE2-W21R 160 L6 Ex II 3D	11.0	108	970	IE2- 88.7	87.9	86.3	0.85	21	5.8	2.2	1.9	2.7	0.145	135
IE2-WE1R 160 L6 Ex II 3D	11.0	108	975	IE2- 88.9	88.8	87.0	0.81	22	6.8	2.7	2.4	3.1	0.166	155
IE2-W21R 180 L6 Ex II 3D	15.0	147	975	IE2- 89.7	88.8	86.7	0.84	28.5	6.2	2.1	1.8	2.8	0.228	185
IE2-WE2R 180 L6 Ex II 3D	15	148	970	IE2- 89.7	88.8	87.8	0.83	29	5.6	2.3	1.7	2.6	0.166	157
IE2-W21R 200 L6 Ex II 3D	18.5	180	980	IE2- 90.4	88.8	86.5	0.85	35	6.6	2.3	1.7	2.9	0.268	208
IE2-W21R 200 LX6 Ex II 3D	22	214	980	IE2- 90.9	90.2	88.5	0.86	40.5	6.4	2.2	1.8	2.7	0.443	272
IE2-WE2R 200 LX6 Ex II 3D	22	215	975	IE2- 90.9	89.9	88.5	0.84	41.5	6.7	2.4	2.0	3.0	0.324	238
IE2-W21R 225 M6 Ex II 3D	30	291	985	IE2- 92.0	91.5	90.0	0.86	54.5	7.3	2.5	2.2	2.9	0.825	365
IE2-WE2R 225 M6 Ex II 3D	30	294	975	IE2- 91.7	91.4	90.6	0.87	54.5	6.7	2.3	1.9	2.8	0.514	308
IE2-W21R 250 M6 Ex II 3D	37	359	985	IE2- 92.2	91.7	90.7	0.85	68	6.4	2.7	1.8	2.4	1.28	480
IE2-WE2R 250 M6 Ex II 3D	37	361	979	IE2- 92.2	92.3	91.8	0.86	67.5	6.6	2.7	2.0	2.6	0.92	407
IE2-W21R 280 S6 Ex II 3D	45	437	983	IE2- 93.0	92.7	92.4	0.87	80.5	6.5	2.2	1.7	2.4	1.48	560
IE2-W21R 280 M6 Ex II 3D	55	531	990	IE2- 93.5	93.5	93.0	0.85	100	7.6	2.0	1.5	2.5	2.63	710
IE2-W21R 315 S6 Ex II 3D	75	723	990	IE2- 93.9	93.7	93.5	0.87	133	7.8	1.9	1.5	2.5	3.33	804
IE2-W21R 315 M6 Ex II 3D	90	868	990	IE2- 94.0	94.0	93.5	0.88	157	7.5	1.8	1.5	2.5	3.60	865
IE2-W21R 315 MX6 Ex II 3D	110	1061	990	IE2- 94.3	94.3	94.0	0.87	194	7.5	1.8	1.4	2.3	6.67	1210
IE2-W21R 315 MY6 Ex II 3D	132	1273	990	IE2- 94.6	94.3	94.0	0.87	231	7.5	1.9	1.4	2.2	6.67	1250
IE2-W21R 315 L6 Ex II 3D	160	1543	990	IE2- 94.8	94.5	93.5	0.88	277	7.5	2.0	1.5	2.4	8.60	1430
IE2-W21R 315 LX6 Ex II 3D	200	1929	990	IE2- 95.0	95.0	94.5	0.86	353	7.0	1.9	1.5	2.2	8.60	1460
IE2-W22R 355 M6 Ex II 3D	200	1920	995	IE2- 95.0	95.0	94.0	0.82	371	8.0	1.7	1.4	2.6	8.20	1850
IE2-W22R 355 MX6 Ex II 3D	315	3023	995	IE2- 95.0	95.0	94.5	0.85	447	7.5	1.6	1.2	2.5	12.1	2200
IE2-W22R 355 LY6 Ex II 3D	355	3407	995	IE2- 95.3	95.3	95.3	0.86	555	8.0	2.1	1.3	2.6	14.0	2400

IP 65 required for conductive dust! Ex tc IIIC T125 °C Dc
Other voltages and frequencies upon request. Changes are possible for motors which are not yet certified.
*** upon request

Three-phase motors with squirrel-cage rotor, High Efficiency IE2
Type of explosion protection – Protection by enclosure „tc“
for operation in Zone 22 according to EN 60079-31

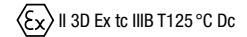

for rated voltage, temperature classes T1, T2 and T3
 with surface cooling, duty type S1, continuous duty
 thermal class F, degree of protection IP 55, 50 Hz

Motor selection data													Design point 400 V, 50 Hz		
Type	P	M _B	n _B	η _B			cosφ _B	I _B	I _R /I _B	M _R /M _B	M _S /M _B	M _K /M _B	J	m	
	kW	Nm	rpm	(IEC/EN 60034-30-1)			-	400 V	-	-	-	-	kgm ²	kg	
Synchronous speed 750 rpm – 8-pole version															
IE2-W21R 132 S8 Ex II 3D	2.2	29.2	720	IE2- 81.7	81.0	77.5	0.65	6	4.8	2.2	2.0	3.2	0.0180	55	
IE2-W21R 132 M8 Ex II 3D	3.0	39.8	720	IE2- 82.7	83.0	81.3	0.74	7.1	3.9	1.6	1.3	1.9	0.0430	74	
IE2-WE2R 132 M8 Ex II 3D	3	39.8	720	IE2- ***)	***)	***)	***)	***)	***)	***)	***)	***)	0.0290	65	
IE2-W21R 160 M8 Ex II 3D	4.0	53.2	718	IE2- 84.2	83.7	81.9	0.72	9.5	4.6	1.6	***)	2.5	0.0530	86	
IE2-W21R 160 MX8 Ex II 3D	5.5	72.0	730	IE2- 86.9	86.6	84.1	0.72	12.5	4.8	2.1	1.8	2.6	0.1130	115	
IE2-WE2R 160 MX8 Ex II 3D	5.5	73	715	IE2- 83.9	84.0	81.9	0.71	13.5	4.3	1.7	1.5	2.5	0.0530	103	
IE2-W21R 160 L8 Ex II 3D	7.5	99	725	IE2- 87.5	87.0	83.5	0.77	16	5.5	2.0	***)	2.8	0.1450	136	
IE2-W21R 180 L8 Ex II 3D	11.0	144	727	IE2- 88.2	88.2	86.7	0.78	23	4.9	1.8	1.6	2.4	0.2280	175	
IE2-WE2R 180 L8 Ex II 3D	11	144	730	IE2- 87.9	87.4	85.2	0.67	25.5	4.3	1.9	1.6	2.3	0.1660	157	
IE2-W21R 200 L8 Ex II 3D	15.0	197	727	IE2- 88.2	88.1	86.4	0.77	32	4.9	1.9	1.7	2.3	0.2680	200	
IE2-W21R 225 S8 Ex II 3D	18.5	242	730	IE2- 89.6	89.4	87.2	0.78	38	5.4	2.1	2.0	2.8	0.440	265	
IE2-WE2R 225 S8 Ex II 3D	18.5	240	735	IE2- 90.7	90.7	89.4	0.8	37	6.1	2.1	1.9	2.9	0.514	305	
IE2-W21R 225 M8 Ex II 3D	22	287	733	IE2- 90.6	89.4	89.9	0.78	45	5.6	2.2	1.8	2.6	0.825	380	
IE2-WE2R 225 M8 Ex II 3D	22	286	735	IE2- 90.3	90.3	88.7	0.77	45.5	6.1	2.2	2.0	2.9	0.514	307	
IE2-W21R 250 M8 Ex II 3D	30	389	737	IE2- 92.1	92.4	91.6	0.79	59.5	5.0	2.0	1.6	2.1	1.350	480	
IE2-WE2R 250 M8 Ex II 3D	30	391	732	IE2- 91.5	91.7	90.9	0.77	61.5	5.6	2.3	2.0	2.5	0.950	405	
IE2-W21R 280 S8 Ex II 3D	37	479	737	IE2- 92.2	92.1	90.9	0.79	73.5	6.0	2.3	1.9	2.5	1.55	550	
IE2-W21R 280 M8 Ex II 3D	45	581	740	IE2- 92.7	92.7	92.0	0.79	88.5	6.7	1.8	1.5	2.5	2.63	690	
IE2-W21R 315 S8 Ex II 3D	55	710	740	IE2- 92.2	92.2	92.1	0.80	108	6.3	1.8	1.5	2.3	2.63	690	
IE2-W21R 315 M8 Ex II 3D	75	968	740	IE2- 93.5	93.5	93.0	0.81	143	6.0	1.8	1.5	2.1	3.6	880	
IE2-W21R 315 MX8 Ex II 3D	90	1161	740	IE2- 92.1	91.6	90.1	0.81	174	6.0	1.9	***)	2.2	6	1050	
IE2-W21R 315 MY8 Ex II 3D	110	1420	740	IE2- 93.8	93.3	91.2	0.81	209	6.5	2.1	***)	2.4	6.76	1250	
IE2-W21R 315 L8 Ex II 3D	132	1704	740	IE2- 94.4	94.0	93.5	0.83	243	7.5	2.2	1.8	2.5	8.71	1430	
IE2-W21R 315 LX8 Ex II 3D	160	2065	740	IE2- 94.2	94.2	93.8	0.80	306	7.2	2.2	1.8	2.5	8.71	1430	
IE2-W22R 355 M8 Ex II 3D	200	2571	743	IE2- 94.7	94.1	91.5	0.77	396	***)	***)	***)	***)	9.5	1850	
IE2-W22R 355 MX8 Ex II 3D	250	3205	745	IE2- 95.8	95.8	95.5	0.83	454	7.0	1.2	1.0	2.6	13.4	2200	
IE2-W22R 355 LY8 Ex II 3D	280	3599	743	IE2- 94.8	94.1	91.5	0.78	547	***)	***)	***)	***)	15.8	2400	

IP 65 required for conductive dust! Ex tc IIIC T125 °C Dc

Other voltages and frequencies upon request. Changes are possible for motors which are not yet certified.

***) upon request

Three-phase motors with squirrel-cage rotor, Standard Efficiency IE1 Type of explosion protection – Protection by enclosure „tc“ for operation in Zone 22 according to EN 60079-31

II 3D Ex tc IIIB T125 °C Dc

for rated voltage, temperature classes T1, T2 and T3
with surface cooling, duty type S1, continuous duty
thermal class F, degree of protection IP 55, 50 Hz

Motor selection data													Design point 400 V, 50 Hz	
Type	P kW	M _B Nm	n _B rpm	η _B (IEC/EN 60034-30-1)			cos φ _B -	I _B 400 V A	I _N /I _B -	M _N /M _B -	M _S /M _B -	M _R /M _B -	J kgm ²	m kg
				100 %	75 %	50 %								
Synchronous speed 3000 rpm – 2-pole version														
IE1-KPE0 56 K2 Ex II 3D	0.09	0.3	2840	IE1- 70.2	68.1	64.5	0.74	0.25	4.9	2.3	2.3	2.8	0.00013	4.4
IE1-KPER 56 G2 Ex II 3D	0.12	0.41	2830	IE1- 70.3	67.0	60.1	0.77	0.32	4.5	2.1	2.1	2.3	0.00013	4.5
IE1-KPER 63 K2 Ex II 3D	0.18	0.62	2790	IE1- 67.0	65.6	59.8	0.76	0.51	4.1	1.9	1.9	2.2	0.00013	4.9
IE1-KPER 63 G2 Ex II 3D	0.25	0.85	2800	IE1- 67.7	64.9	56.2	0.72	0.74	4.2	2.2	2.2	2.4	0.00015	5.2
IE1-KPER 71 K2 Ex II 3D	0.37	1.27	2780	IE1- 71.9	70.8	65.0	0.79	0.94	4.4	2.1	2.1	2.3	0.00025	6.7
IE1-KPER 71 G2 Ex II 3D	0.55	1.89	2775	IE1- 74.2	75.0	72.0	0.81	1.32	5.1	2.3	2.1	2.6	0.00032	7.6
IE1-KPER 80 K2 Ex II 3D	0.75	2.54	2825	IE1- 76.8	77.5	74.3	0.82	1.72	5.9	2.4	2.4	2.4	0.00057	10.7
IE1-KPER 80 G2 Ex II 3D	1.1	3.71	2835	IE1- 76.9	75.9	73.3	0.81	2.55	6.0	2.4	2.3	2.6	0.00072	11.5
IE1-KPER 90 S2 Ex II 3D	1.5	5.04	2840	IE1- 81.2	82.2	80.3	0.86	3.1	7.0	2.5	2.5	2.8	0.00132	16.0
IE1-KPER 90 L2 Ex II 3D	2.2	7.37	2850	IE1- 82.1	83.4	81.9	0.85	4.55	7.5	2.8	2.3	2.9	0.0017	19.0
IE1-KPER 100 L2 Ex II 3D	3.0	10	2865	IE1- 82.8	83.1	83.3	0.85	6.15	6.8	2.4	2.2	2.8	0.00275	25.0
IE1-KPER 112 M2 Ex II 3D	4.0	13.2	2900	IE1- 84.9	85.5	84.4	0.81	8.4	7.0	2.2	2.1	2.9	0.0045	32
IE1-KPER 112 MX2 Ex II 3D	5.5	18.2	2890	IE1- 85.9	86.2	86.4	0.84	11.0	7.5	2.4	2.2	3.0	0.0055	40
IE1-KPER 132 S2T Ex II 3D	5.5	18.2	2890	IE1- 85.9	86.2	86.4	0.84	11.0	7.5	2.4	2.2	3.0	0.0055	40
IE1-KPER 132 SX2T Ex II 3D	7.5	24.9	2880	IE1- 87.1	87.2	86.6	0.84	14.8	6.3	1.5	1.2	2.6	0.0680	48
IE1-K21R 132 S2 Ex II 3D	5.5	18	2860	IE1- 84.7	84.7	82.4	0.86	11	5.5	1.8	1.6	2.2	0.0081	50
IE1-K21R 132 SX2 Ex II 3D	7.5	25	2900	IE1- 86.0	86.0	84.0	0.86	14.5	6.6	1.8	1.3	2.5	0.0110	59
IE1-K21R 160 M2 Ex II 3D	11.0	36	2900	IE1- 87.6	87.6	84.6	0.90	20	7.0	2.4	2.0	3.0	0.0258	88
IE1-K21R 160 MX2 Ex II 3D	15.0	49	2930	IE1- 88.7	88.7	85.8	0.90	27	7.1	2.2	1.7	2.9	0.0575	131
IE1-K21R 160 L2 Ex II 3D	18.5	61	2920	IE1- 89.3	88.3	85.8	0.92	32.5	7.2	2.1	1.6	2.8	0.0675	138
IE1-K21R 180 M2 Ex II 3D	22	72	2935	IE1- 89.9	89.1	86.1	0.92	38.5	6.8	1.7	1.4	2.6	0.105	178
IE1-K21R 200 L2 Ex II 3D	30	97	2940	IE1- 91.1	90.3	88.8	0.92	51.5	7.3	2.0	1.6	2.9	0.128	207
IE1-K21R 200 LX2 Ex II 3D	37	120	2940	IE1- 91.5	90.5	89.0	0.90	65	7.0	1.8	1.3	2.4	0.193	265
IE1-K21R 225 M2 Ex II 3D	45	146	2940	IE1- 92.0	91.3	88.8	0.91	77.5	7.5	1.8	1.4	2.7	0.220	295
IE1-K21R 250 M2 Ex II 3D	55	178	2955	IE1- 92.2	91.0	89.0	0.91	94.5	7.5	2.0	1.5	2.6	0.375	383
IE1-K21R 280 S2 Ex II 3D	75	241	2970	IE1- 93.1	92.0	90.5	0.92	126	7.5	2.0	1.6	2.6	0.650	505
IE1-K21R 280 M2 Ex II 3D	90	289	2970	IE1- 93.2	92.7	90.5	0.91	153	8.5	2.2	1.8	2.8	0.675	546
IE1-K21R 315 S2 Ex II 3D	110	353	2975	IE1- 93.5	92.6	91.1	0.91	187	8.5	1.5	1.3	2.5	1.21	720
IE1-K21R 315 M2 Ex II 3D	132	424	2975	IE1- 93.8	92.9	91.9	0.91	223	8.5	2.0	1.8	2.7	1.44	800
IE1-K21R 315 MX2 Ex II 3D	160	514	2975	IE1- 94.0	94.0	94.0	0.91	270	8.5	1.5	1.0	2.0	1.76	980
IE1-K21R 315 MY2 Ex II 3D	200	643	2970	IE1- 94.0	93.2	92.5	0.92	334	8.2	2.6	2.0	2.6	2.82	1170
IE1-K21R 315 L2 Ex II 3D	250	803	2973	IE1- 94.1	93.2	93.0	0.93	412	7.3	2.1	1.4	2.0	3.66	1460
IE1-K21R 315 LX2 Ex II 3D	315	1010	2980	IE1- 94.5	94.5	92.8	0.92	523	8.6	2.7	1.7	2.4	4.43	1630
IE1-K22R 355 MY2G Ex II 3D	315	1007	2988	IE1- 94.5	94.3	93.7	0.88	547	8.6	1.3	1.0	3.0	4.10	1900
IE1-K22R 355 M2G Ex II 3D	355	1138	2980	IE1- 94.3	94.3	93.8	0.91	597	7.3	1.3	1.0	2.3	4.20	2000
IE1-K22R 355 MX2G Ex II 3D	400	1280	2985	IE1- 94.6	94.5	93.8	0.90	678	8.5	1.9	1.3	3.2	5.50	2200
IE1-K22R 355 L2G Ex II 3D	450	1441	2983	IE1- 94.7	94.5	93.8	0.92	746	7.2	1.3	1.0	2.4	7.10	2400

Progressive series KPR/K10R possible upon request
IP 65 required for conductive dust! Ex tc IIIC T125 °C Dc
Other voltages and frequencies upon request. Changes are possible for motors which are not yet certified.

Three-phase motors with squirrel-cage rotor, Standard Efficiency IE1
Type of explosion protection – Protection by enclosure „tc“
for operation in Zone 22 according to EN 60079-31

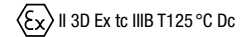

for rated voltage, temperature classes T1, T2 and T3
 with surface cooling, duty type S1, continuous duty
 thermal class F, degree of protection IP 55, 50 Hz

Motor selection data													Design point 400 V, 50 Hz	
Type	P	M _B	n _B	η _B			cosφ _B	I _B	I _A /I _B	M _A /M _B	M _S /M _B	M _K /M _B	J	m
	kW	Nm	rpm	(IEC/EN 60034-30-1)			-	A	-	-	-	-	kgm ²	kg
Synchronous speed 1500 rpm – 4-pole version														
IE1-KPE0 56 K4 Ex II 3D	0.06	0.41	1410	IE1- 60.1	56.5	49.6	0.60	0.24	3.1	2.3	2.3	2.7	0.00019	4.3
IE1-KPER 56 G4 Ex II 3D	0.09	0.63	1375	IE1- 61.6	58.7	53.0	0.68	0.31	3.2	1.9	1.9	2.2	0.00019	4.4
IE1-KPER 63 K4 Ex II 3D	0.12	0.84	1370	IE1- 57.9	51.2	42.2	0.68	0.44	3.2	1.9	1.8	2.2	0.00019	4.8
IE1-KPER 63 G4 Ex II 3D	0.18	1.26	1360	IE1- 60.6	57.5	49.4	0.66	0.65	3.3	2.0	2.0	2.3	0.00024	5.2
IE1-KPER 71 K4 Ex II 3D	0.25	1.72	1385	IE1- 64.3	63.2	58.2	0.72	0.78	3.6	1.8	1.8	2.1	0.00040	6.8
IE1-KPER 71 G4 Ex II 3D	0.37	2.58	1370	IE1- 68.1	66.7	62.0	0.74	1.06	3.8	2.0	2.0	2.2	0.00050	7.8
IE1-KPER 80 K4 Ex II 3D	0.55	3.75	1400	IE1- 71.9	70.7	64.1	0.69	1.6	4.1	2.1	2.0	2.3	0.00087	10.6
IE1-KPER 80 G4 Ex II 3D	0.75	5.12	1400	IE1- 73.6	72.2	66.8	0.70	2.1	4.6	2.2	2.1	2.3	0.00107	11.7
IE1-KPER 90 S4 Ex II 3D	1.1	7.45	1410	IE1- 76.7	76.8	73.6	0.79	2.62	5.5	2.3	2.2	2.5	0.00207	15.5
IE1-KPER 90 L4 Ex II 3D	1.5	10.2	1400	IE1- 78.6	79.1	76.9	0.81	3.4	5.5	2.5	2.4	2.6	0.00260	18.0
IE1-KPER 100 L4 Ex II 3D	2.2	14.9	1410	IE1- 80.2	80.7	79.5	0.80	4.95	6.0	2.5	2.3	2.7	0.00400	23.5
IE1-KPER 100 LX4 Ex II 3D	3.0	20	1430	IE1- 82.4	82.8	80.8	0.79	6.65	6.5	2.5	2.2	2.9	0.00725	30
IE1-KPER 112 M4 Ex II 3D	4.0	26.6	1435	IE1- 84.1	85.1	83.6	0.78	8.8	6.9	2.6	2.5	3.2	0.009	37
IE1-KPER 112 MX4 Ex II 3D	5.5	36.9	1425	IE1- 85.2	86.5	85.8	0.79	11.8	6.3	2.5	2.4	2.9	0.011	47
IE1-KPER 132 S4T Ex II 3D	5.5	36.9	1425	IE1- 85.2	86.5	85.8	0.79	11.8	6.3	2.5	2.4	2.9	0.011	47
IE1-K21R 132 S4 Ex II 3D	5.5	36	1440	IE1- 84.9	84.9	83.4	0.89	10.5	6.5	1.9	1.7	3.0	0.015	51
IE1-K21R 132 M4 Ex II 3D	7.5	49	1450	IE1- 86.5	85.5	84.0	0.84	15	6.0	2.0	1.7	2.9	0.028	73
IE1-K21R 160 M4 Ex II 3D	11.0	72	1450	IE1- 88.0	87.6	85.6	0.85	21	6.8	2.2	1.9	3.3	0.035	92
IE1-K21R 160 L4 Ex II 3D	15.0	98	1465	IE1- 88.7	88.3	85.8	0.86	28.5	7.3	2.5	2.0	3.0	0.078	132
IE1-K21R 180 M4 Ex II 3D	18.5	121	1460	IE1- 89.3	88.8	86.8	0.86	35	6.8	2.5	2.0	2.9	0.090	145
IE1-K21R 180 L4 Ex II 3D	22	143	1465	IE1- 89.9	89.9	88.4	0.84	42	6.5	2.0	1.8	2.6	0.138	185
IE1-K21R 200 L4 Ex II 3D	30	196	1465	IE1- 90.7	90.2	89.2	0.85	56	7.0	2.0	1.7	2.4	0.168	211
IE1-K21R 225 S4 Ex II 3D	37	240	1470	IE1- 91.2	90.2	89.2	0.86	68	7.0	2.0	1.7	2.5	0.275	282
IE1-K21R 225 M4 Ex II 3D	45	292	1470	IE1- 91.7	91.2	89.7	0.86	82.5	7.0	2.0	1.7	2.5	0.313	323
IE1-K21R 250 M4 Ex II 3D	55	356	1475	IE1- 92.3	91.8	90.8	0.86	100	7.0	2.2	1.7	2.3	0.525	394
IE1-K21R 280 S4 Ex II 3D	75	484	1480	IE1- 92.7	92.1	90.6	0.86	136	7.0	2.0	1.7	2.2	0.950	540
IE1-K21R 280 M4 Ex II 3D	90	581	1480	IE1- 93.3	92.2	89.7	0.86	162	7.0	2.1	1.6	2.2	1.10	610
IE1-K21R 315 S4 Ex II 3D	110	707	1485	IE1- 93.5	92.9	91.4	0.86	197	7.5	1.8	1.6	2.2	1.96	740
IE1-K21R 315 M4 Ex II 3D	132	849	1485	IE1- 93.5	92.9	91.9	0.86	237	7.0	1.8	1.5	2.2	2.27	840
IE1-K21R 315 MX4 Ex II 3D	160	1032	1480	IE1- 93.8	93.6	92.8	0.87	283	7.0	1.8	1.5	2.0	2.73	1000
IE1-K21R 315 MY4 Ex II 3D	200	1286	1485	IE1- 94.3	93.3	92.8	0.88	348	7.5	2.0	1.8	2.4	4.82	1200
IE1-K21R 315 L4 Ex II 3D	250	1608	1485	IE1- 94.3	93.2	92.7	0.90	425	8.0	2.0	1.6	2.3	5.93	1510
IE1-K21R 315 LX4 Ex II 3D	315	2019	1490	IE1- 94.5	93.5	93.2	0.88	547	8.6	1.9	1.5	2.5	6.82	1630
IE1-K22R 355 MY4 Ex II 3D	315	2016	1492	IE1- 94.0	93.9	92.4	0.85	569	7.1	1.4	1.0	2.9	5.60	1950
IE1-K22R 355 M4 Ex II 3D	355	2275	1490	IE1- 94.5	94.2	93.2	0.84	646	8.1	1.8	1.0	3.1	7.9	2150
IE1-K22R 355 MX4 Ex II 3D	400	2557	1494	IE1- 94.5	94.4	93.7	0.84	727	8.6	1.3	1.0	3.0	9.5	2400
IE1-K22R 355 L4 Ex II 3D	450	2884	1490	IE1- 94.5	94.4	93.7	0.82	838	8.0	1.2	1.0	3.0	10.0	2500

Progressive series KPR/K10R possible upon request
 IP 65 required for conductive dust! Ex tc IIIC T125 °C Dc
 Other voltages and frequencies upon request. Changes are possible for motors which are not yet certified.

Three-phase motors with squirrel-cage rotor, Standard Efficiency IE1
Type of explosion protection – Protection by enclosure „tc“
for operation in Zone 22 according to EN 60079-31

II 3D Ex tc IIIB T125 °C Dc

for rated voltage, temperature classes T1, T2 and T3
 with surface cooling, duty type S1, continuous duty
 thermal class F, degree of protection IP 55, 50 Hz

Motor selection data													Design point 400 V, 50 Hz	
Type	P	M _B	n _B	η _B			cos φ _B	I _B	I _R /I _B	M _R /M _B	M _S /M _B	M _V /M _B	J	m
	kW	Nm	rpm	(IEC/EN 60034-30-1)			-	400 V	-	-	-	-	kgm ²	kg
Synchronous speed 1000 rpm – 6-pole version														
	100 %	75 %	50 %											
IE1-KPER 63 K6 Ex II 3D	0.09	0.96	895	IE1- 50.4	46.2	38.4	0.56	0.46	2.5	2.0	2.0	2.4	0.00024	4.9
IE1-KPER 63 G6 Ex II 3D	0.12	1.3	880	IE1- 52.4	50.1	43.2	0.56	0.59	2.5	2.0	2.0	2.3	0.00027	5.7
IE1-KPER 71 K6 Ex II 3D	0.18	1.86	925	IE1- 57.9	53.9	45.4	0.51	0.88	2.8	1.6	1.6	2.1	0.00045	7.4
IE1-KPER 71 G6 Ex II 3D	0.25	2.61	915	IE1- 59.6	57.5	49.5	0.55	1.1	2.9	2.0	2.0	2.2	0.00060	8.3
IE1-KPER 80 K6 Ex II 3D	0.37	3.86	915	IE1- 66.3	64.5	57.1	0.66	1.22	3.4	2.0	2.0	2.0	0.00130	11.0
IE1-KPER 80 G6 Ex II 3D	0.55	5.74	915	IE1- 68.5	67.0	60.7	0.67	1.73	3.7	2.2	2.2	2.4	0.00175	12.5
IE1-KPER 90 S6 Ex II 3D	0.75	7.66	935	IE1- 70.5	68.8	63.2	0.64	2.4	4.5	2.4	2.4	2.6	0.00325	16.0
IE1-KPER 90 L6 Ex II 3D	1.1	11.24	935	IE1- 73.4	73.0	68.4	0.68	3.18	4.6	2.2	2.2	2.6	0.00425	19.0
IE1-KPER 100 L6 Ex II 3D	1.5	15.16	945	IE1- 76.0	75.2	71.1	0.73	3.9	4.6	2.1	2.0	2.4	0.00625	24.0
IE1-KPER 112 M6 Ex II 3D	2.2	22.12	950	IE1- 78.1	78.8	75.8	0.76	5.35	5.3	2.2	2.1	2.7	0.01225	33.5
IE1-KPER 132 S6T Ex II 3D	3.0	30.6	935	IE1- 81.9	82.8	81.4	0.75	7.05	5.2	2.5	2.5	2.9	0.0139	39.0
IE1-K21R 132 S6 Ex II 3D	3.0	30	955	IE1- 79.7	79.7	76.2	0.82	6.6	5.7	1.8	1.6	2.7	0.0180	46
IE1-K21R 132 M6 Ex II 3D	4.0	40	955	IE1- 81.4	80.4	75.4	0.80	8.9	6.0	2.2	2.0	3.1	0.0230	56
IE1-K21R 132 MX6 Ex II 3D	5.5	55	955	IE1- 83.3	83.3	81.3	0.83	11.5	5.0	1.8	1.5	2.3	0.0430	72
IE1-K21R 160 M6 Ex II 3D	7.5	75	960	IE1- 85.0	84.0	80.0	0.82	15.5	5.5	2.0	1.6	2.5	0.0530	91
IE1-K21R 160 L6 Ex II 3D	11.0	109	965	IE1- 86.4	86.2	84.2	0.86	21.5	5.0	2.0	1.7	2.3	0.1130	122
IE1-K21R 180 L6 Ex II 3D	15.0	148	965	IE1- 87.7	86.7	83.7	0.83	29.5	6.0	2.4	2.1	2.7	0.1450	142
IE1-K21R 200 L6 Ex II 3D	18.5	182	970	IE1- 88.6	88.5	86.5	0.87	34.5	5.5	2.0	1.7	2.4	0.2280	190
IE1-K21R 200 LX6 Ex II 3D	22	217	970	IE1- 89.2	88.9	86.4	0.87	41	6.2	2.2	1.8	2.6	0.2680	208
IE1-K21R 225 M6 Ex II 3D	30	295	973	IE1- 90.2	89.8	87.8	0.89	54	6.5	2.2	1.7	2.5	0.4430	284
IE1-K21R 250 M6 Ex II 3D	37	362	975	IE1- 90.8	90.6	87.8	0.89	66	6.5	2.2	1.7	2.3	0.8250	376
IE1-K21R 280 S6 Ex II 3D	45	439	980	IE1- 91.4	91.4	89.4	0.87	81.5	6.0	2.0	1.5	2.0	1.28	465
IE1-K21R 280 M6 Ex II 3D	55	536	980	IE1- 91.9	91.4	89.4	0.88	98	6.5	2.3	1.7	2.4	1.48	575
IE1-K21R 315 S6 Ex II 3D	75	727	985	IE1- 92.7	92.0	91.0	0.87	134	7.0	2.0	1.6	2.4	2.63	690
IE1-K21R 315 M6 Ex II 3D	90	868	990	IE1- 93.4	92.5	91.0	0.88	158	7.0	2.0	1.7	2.4	3.33	800
IE1-K21R 315 MX6 Ex II 3D	110	1061	990	IE1- 93.3	93.1	91.6	0.88	193	7.5	2.2	1.7	2.6	3.60	880
IE1-K21R 315 MY6 Ex II 3D	132	1273	990	IE1- 94.0	93.7	92.5	0.88	230	7.5	2.0	1.7	2.4	6.00	1050
IE1-K21R 315 L6 Ex II 3D	160	1551	985	IE1- 94.3	94.0	92.8	0.89	275	7.5	2.3	1.9	2.4	6.67	1250
IE1-K21R 315 LX6 Ex II 3D	200	1929	990	IE1- 94.2	93.9	93.2	0.87	352	8.3	2.2	2.0	2.7	8.6	1460
IE1-K22R 355 MY6 Ex II 3D	180	1735	990	IE1- 94.0	94.1	95.3	0.86	321	8.5	2.5	1.6	2.6	8.1	1550
IE1-K22R 355 M6 Ex II 3D	250	2402	994	IE1- 94.5	94.2	93.3	0.81	471	7.0	1.8	1.3	2.3	8.2	1850
IE1-K22R 355 MX6 Ex II 3D	315	3023	995	IE1- 94.5	94.5	93.8	0.83	580	6.8	1.6	1.3	2.5	12.1	2200
IE1-K22R 355 LY6 Ex II 3D	355	3407	995	IE1- 94.4	94.2	92.4	0.78	696	7.4	1.9	1.4	2.6	14.0	2400

Progressive series KPR/K10R possible upon request
 IP 65 required for conductive dust! Ex tc IIIC T125 °C Dc
 Other voltages and frequencies upon request. Changes are possible for motors which are not yet certified.

Three-phase motors with squirrel-cage rotor, Standard Efficiency IE1
Type of explosion protection – Protection by enclosure „tc“
for operation in Zone 22 according to EN 60079-31

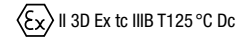

for rated voltage, temperature classes T1, T2 and T3
 with surface cooling, duty type S1, continuous duty
 thermal class F, degree of protection IP 55, 50 Hz

Motor selection data													Design point 400 V, 50 Hz	
Type	P	M _b	n _b	η _B			cosφ _B	I _B	I _R /I _B	M _R /M _B	M _S /M _B	M _K /M _B	J	m
	kW	Nm	rpm	(IEC/EN 60034-30-1)			-	400 V	-	-	-	-	kgm ²	kg
Synchronous speed 750 rpm – 8-pole version														
IE1-KPER 71 K8 Ex II 3D	0.09	1.27	675	- 45.5	42.1	34.8	0.51	0.56	2.1	1.9	1.9	2.1	0.00050	6.6
IE1-KPER 71 G8 Ex II 3D	0.12	1.71	670	- 46.5	42.1	33.7	0.51	0.73	2.3	1.8	1.8	2.1	0.00060	8.1
IE1-KPER 80 K8 Ex II 3D	0.18	2.49	690	- 56.5	53.4	45.0	0.59	0.78	2.8	2.0	2.0	2.2	0.00130	10.5
IE1-KPER 80 G8 Ex II 3D	0.25	3.44	695	- 57.5	54.1	46.1	0.56	1.12	3.0	2.3	2.3	2.5	0.00175	12.0
IE1-KPER 90 S8 Ex II 3D	0.37	5.05	700	- 61.8	59.7	52.8	0.54	1.60	3.0	1.9	1.9	2.1	0.00300	15.0
IE1-KPER 90 L8 Ex II 3D	0.55	7.56	695	- 64.8	62.5	55.8	0.60	2.04	3.2	1.9	1.9	2.2	0.00375	18.0
IE1-KPER 100 L8 Ex II 3D	0.75	10.2	705	- 66.8	64.7	57.9	0.60	2.70	3.3	1.8	1.8	2.2	0.00625	23.0
IE1-KPER 100 LX8 Ex II 3D	1.1	14.9	705	- 72.9	73.3	69.6	0.67	3.25	4.0	2.0	2.0	2.4	0.00900	28.0
IE1-KPER 112 M8 Ex II 3D	1.5	20.3	705	- 75.4	75.7	72.4	0.70	4.10	4.4	2.2	2.1	2.5	0.01225	33.5
IE1-KPER 132 S8T Ex II 3D	2.2	31	685	- 74.1	74.8	72.4	0.68	6.30	3.8	2.0	1.9	2.3	0.01390	39.0
IE1-K21R 132 S8 Ex II 3D	2.2	30	705	IE1- 75.5	75.0	72.0	0.76	5.5	4.5	1.7	1.6	2.3	0.01800	46
IE1-K21R 132 M8 Ex II 3D	3.0	41	705	IE1- 78.0	78.0	75.0	0.75	7.4	4.5	1.7	1.6	2.3	0.0230	53
IE1-K21R 160 M8 Ex II 3D	4.0	54	710	IE1- 79.3	79.0	77.0	0.78	9.3	4.0	1.6	1.3	1.9	0.0430	70
IE1-K21R 160 MX8 Ex II 3D	5.5	74	710	IE1- 81.4	81.0	78.0	0.78	12.5	4.5	1.7	1.6	2.1	0.0530	86
IE1-K21R 160 L8 Ex II 3D	7.5	99	725	IE1- 83.0	83.0	79.0	0.78	16.5	4.5	1.8	1.6	2.1	0.1130	114
IE1-K21R 180 L8 Ex II 3D	11.0	146	720	IE1- 85.0	84.0	81.5	0.78	24	4.5	2.0	1.7	2.1	0.1450	136
IE1-K21R 200 L8 Ex II 3D	15.0	198	725	IE1- 86.5	86.0	83.0	0.79	31.5	5.0	2.0	1.7	2.3	0.228	175
IE1-K21R 225 S8 Ex II 3D	18.5	244	725	IE1- 89.2	88.0	86.0	0.83	36	5.5	2.0	1.6	2.2	0.440	265
IE1-K21R 225 M8 Ex II 3D	22	290	725	IE1- 89.2	89.0	88.5	0.84	42.5	5.0	1.8	1.5	2.2	0.440	265
IE1-K21R 250 M8 Ex II 3D	30	393	730	IE1- 89.7	89.5	86.5	0.79	61	5.5	2.2	1.8	2.2	0.825	360
IE1-K21R 280 S8 Ex II 3D	37	481	735	IE1- 90.5	90.0	87.5	0.80	74	5.5	2.0	1.5	2.0	1.35	465
IE1-K21R 280 M8 Ex II 3D	45	585	735	IE1- 91.0	90.5	88.0	0.77	92.5	6.0	2.3	1.8	2.4	1.55	520
IE1-K21R 315 S8 Ex II 3D	55	710	740	IE1- 92.1	91.0	89.5	0.80	108	6.5	1.8	1.6	2.3	2.63	690
IE1-K21R 315 M8 Ex II 3D	75	968	740	IE1- 92.3	92.0	90.5	0.81	145	6.0	2.0	1.6	2.3	3.33	800
IE1-K21R 315 MX8 Ex II 3D	90	1162	740	IE1- 92.5	92.0	90.5	0.81	173	6.0	1.9	1.6	2.2	3.60	880
IE1-K21R 315 MY8 Ex II 3D	110	1420	740	IE1- 93.6	93.0	91.0	0.81	209	6.5	2.1	1.8	2.4	6.00	1100
IE1-K21R 315 L8 Ex II 3D	132	1704	740	IE1- 94.0	93.3	91.0	0.83	244	6.3	2.0	1.7	2.1	6.76	1250
IE1-K21R 315 LX8 Ex II 3D	160	2065	740	IE1- 94.2	93.5	91.0	0.79	310	7.2	2.2	1.9	2.5	8.71	1430
IE1-K22R 355 MY8 Ex II 3D	160	2054	744	IE1- 93.5	93.3	92.5	0.80	309	6.8	1.3	1.0	2.5	9.3	1700
IE1-K22R 355 M8 Ex II 3D	200	2571	743	IE1- 93.9	93.6	92.8	0.77	399	6.5	1.6	1.0	2.7	9.5	1850
IE1-K22R 355 MX8 Ex II 3D	250	3209	744	IE1- 94.1	93.9	92.8	0.78	492	6.6	1.3	1.0	2.8	13.4	2200
IE1-K22R 355 LY8 Ex II 3D	280	3594	744	IE1- 93.6	93.4	92.3	0.78	554	8.2	1.2	1.0	2.8	15.8	2400

Progressive series KPR/K10R possible upon request
 IP 65 required for conductive dust! Ex tc IIIC T125 °C Dc
 Other voltages and frequencies upon request. Changes are possible for motors which are not yet certified.

Terminal boxes

Type of explosion protectionen „n“ („ec“)/Increased safety „e“ („eb“), protection by enclosure „tb“ and „tc“

Overview of terminal boxes

Type Ex e IIC	Terminal plate	$I_{B \max}$	$Q_{B \min}$	$Q_{B \max}$	Terminal type	Terminal thread	a
		[A]	[mm ²]	[mm ²]			[mm]
KA 05-13	KB 5580	27.5		2.5	U-clamp terminal	M4	
25 A	KB 3Ex (KS 10A)	53	6	10	Slotted terminal	S10 x 1	4.3 ± 0.1
63 A	KB 4Ex (KS 14A)	72	10	16	Slotted terminal	S14 x 1.25	6.3 ± 0.2
100 A	KB 4Ex (KS 14A)	72	10	16	Slotted terminal	S14 x 1.25	6.3 ± 0.2
200 A	KB 5Ex (KS 18A)	118	25	35	Slotted terminal	S18 x 1.5	9.2 ± 0.2
25 AV	KL 155	30		4	U-clamp terminal	M5	-
25 AV	KB 5590Ex/d 5.2	35		4	U-clamp terminal	M4	-
63 AV	KB 5121Ex-3	58.5		10	U-clamp terminal	M5	-
100 AV	KB 5121Ex-3	58.5		10	U-clamp terminal	M5	-
100 AV	KB 5130Ex	114		35	U-clamp terminal	M6	-
200 AV	KB 5130Ex	114		35	U-clamp terminal	M6	-
100/63 AV	KM 8/6, VEM 8/6	63		10	Stud/ U-clamp terminal ¹⁾	M6/M5	
200 A-SB	KM 10/8, VEM 10/8	100		70	Stud/ Tab terminal	M8/2xM6	
200 A-SB	KB 5130 Ex	118		35	U-clamp terminal	M6	-
400 A	KM 10/8, VEM 10/8	100		70	Stud/ Tab terminal	M8/2xM6	-
	KM 16/12, VEM 16/12	250		120	Stud/ Tab terminal	M12/2xM10	-
400 AV	KM 10/8, VEM 10/8	100		70	Stud/ Tab terminal	M8/2xM6	-
400 A-SB	KM 10/8, VEM 10/8	100		70	Stud/ Tab terminal	M8/2xM6	-
	KM 16/12, VEM 16/12	250		120	Stud/ Tab terminal	M12/2xM10	-
630 A	VEM KLP 630-16	455	35	300	Stud/ Screw terminal	M16 M12/M8	-
K1X 200 A	KM 10/8, VEM 10/8	100		70	Stud/ Tab terminal	M8/2xM6	-
K2X 200 A	KM 10/8, VEM 10/8	100		70	Stud/ Tab terminal	M8/2xM6	-
K1X 400 A	KM 16/12, VEM 16/12	250		120	Stud/ Tab terminal	M12/2xM10	-
K2X 400 A	KM 16/12, VEM 16/12	250		120	Stud/ Tab terminal	M12/2xM10	-
1000 A	VEM KLP 1000	1000	70	2 x 240	Busbar	M10	-

$I_{B \max}$ max. rated current

$Q_{B \min} / Q_{B \max}$ min./max. rated cross-section

a Slot width of terminal stud (terminal plates to DIN 22412)

¹⁾ for single connection of solid conductors 6...10 mm², conductor bent into a loop

Only cable lugs to DIN 46295 may be used for the motor connection of motors with a terminal plate with slotted terminals. The cable lugs are attached by way of pressure nuts with integrated spring washer. Alternatively, it is permissible to realise connection by way of a solid round conductor whose diameter corresponds to the slot width of the terminal stud.

The numbers of cable glands and their assignment to different motor sizes correspond to the basic version according to DIN 42925 (see also the section "Dimensions" in Chapter 2). Customer-specific designs are possible.

Type of explosion protectionen „n“ („ec“)/Increased safety „e“ („eb“), protection by enclosure „tb“ and „tc“

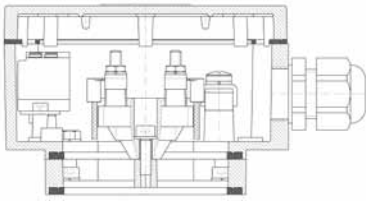

KA 05-13 Ex e IIC

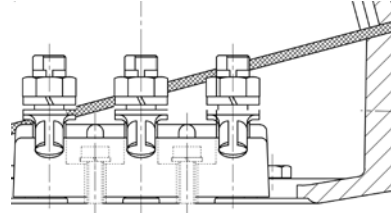
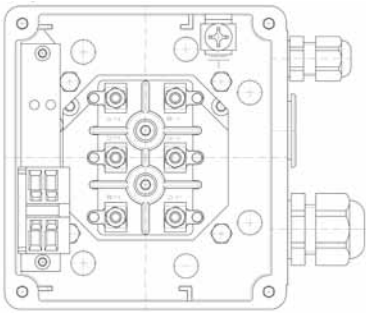

25 A, 63 A, 100 A and 200 A Ex e IIC

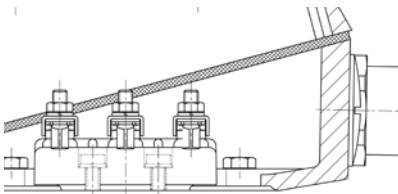
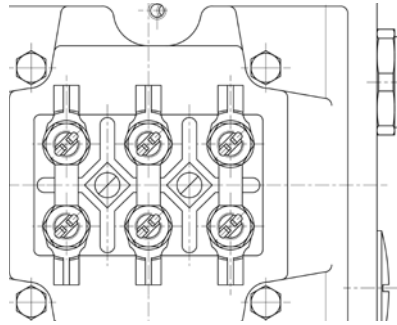

25 AV Ex e IIC

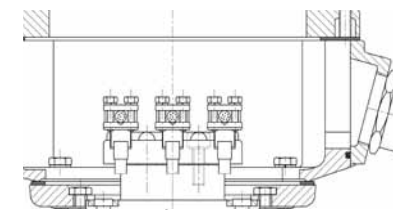
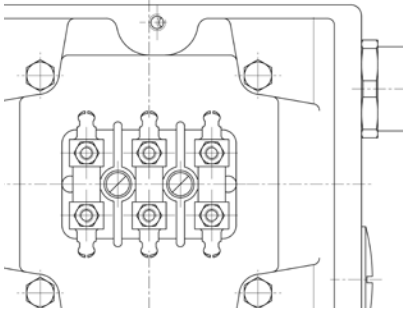

400 A, 400 AV Ex e IIC

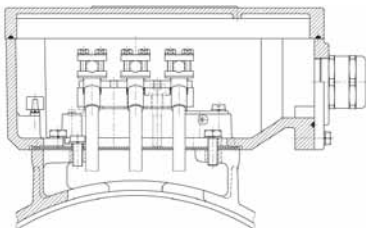
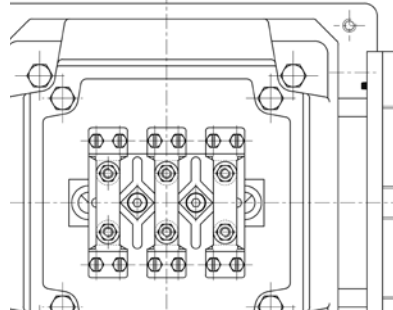

200 B, 400 B Ex e IIC

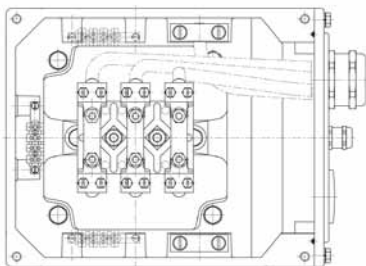

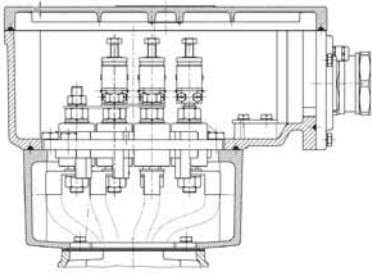

630 A Ex e IIC, gerader ZwischenFlange

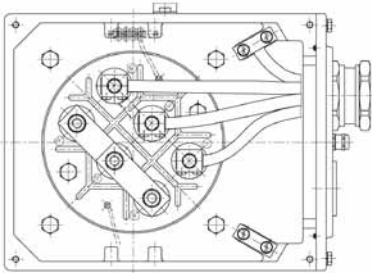

A630 Ex e IIC

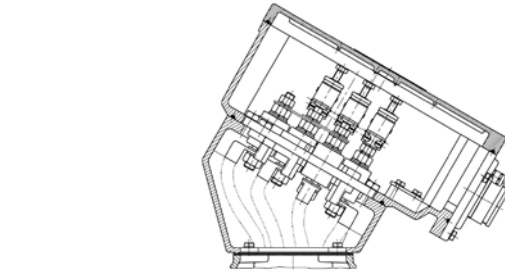

630 A Ex e IIC, inclined adapter flange

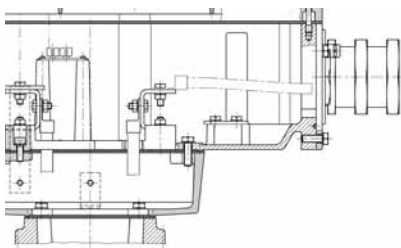
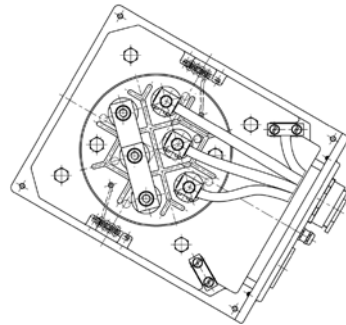

1000 A Ex e IIC, gerader ZwischenFlange

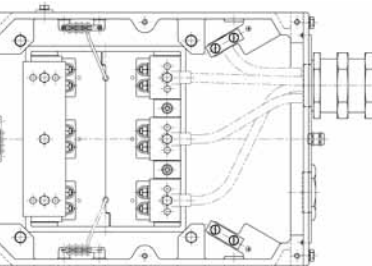

1000 A Ex e IIC

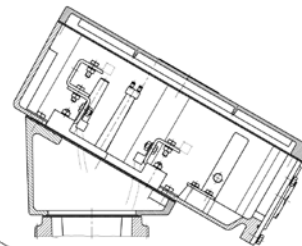

1000 A Ex e IIC, inclined adapter flange

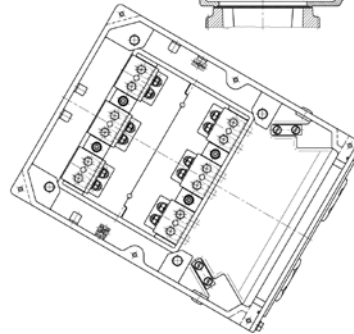

Dimensions

Three-phase motors with squirrel-cage rotor for operation in Zone 2 according to EN 60079-15 (EN 60079-7)

Type of explosion protection „n“ (Increased safety „ec“) and and for operation in Zones 21 and 22 according to EN 60079-31, Type of explosion protection – Protection by enclosure „tb, tc“, Premium Efficiency IE3 (VIK Recommendation 1, Three-Phase Asynchronous Motors – Technical Requirements 03.2011)

with surface cooling, type of cooling IC 411
Size 63 to 180

Type of construction IM B3 [IM 1001]

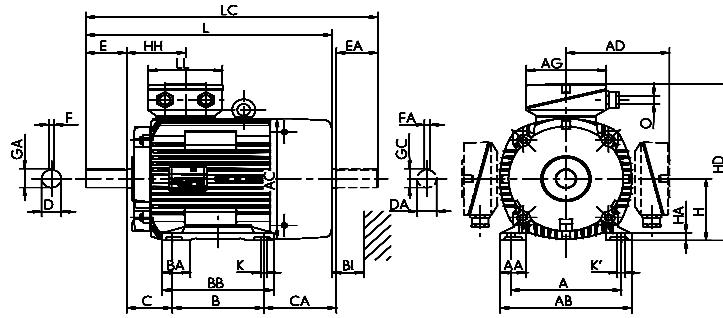

Type designation	Flange size	A	AA	AB	AC	AD	AD VIK	B	BA	BB	C	CA	D	DA	DB ¹⁾	E	EA	F	FA
		b	n	f	g	g1	g1	a	m	e	w1	w2	d	d1	l	l1	u	u1	
IE3-KPER 63 G2, 4	FF 115	100	28	128	109	117	117	80	-	100	40	39	11	11	M4	23	23	4	4
IE3-KPR 63 KY2, G4	FF 115	100	21	120	124	123	123	80	-	95	40	59	11	11	M4	23	23	4	4
IE3-KPER 71 G2, KPR 71 G4	FF 130	112	32	138	124	123	123	90	-	116	45	44	14	14	M5	30	30	5	5
IE3-KPER 80 K2	FF 165	125	38	168	139	111	111	100	-	125	50	63	19	19	M6	40	40	6	6
IE3-KPR 80 K2	FF 165	125	27	152	157	138	138	100	-	124	50	80	19	19	M6	40	40	6	6
IE3-KPR 80 G2, 6, GX4	FF 165	125	27	152	157	138	138	100	-	146	50	102	19	19	M6	40	40	6	6
IE3-KPR 90 S2	FF 165	140	40	178	177	146	146	100	-	130	56	120	24	24	M8	50	50	8	8
IE3-KPR 90 S4	FF 165	140	40	178	177	146	146	100	-	130	56	150	24	24	M8	50	50	8	8
IE3-KPR 90 L2, 6	FF 165	140	40	178	177	146	146	125	-	155	56	125	24	24	M8	50	50	8	8
IE3-KPR 90 LX4	FF 165	140	25	178	177	146	146	125	-	155	56	150	24	24	M8	50	50	8	8
IE3-KPR 100 L2	FF 215	160	42	193	196	155	155	140	-	175	63	102	28	28	M10	60	60	8	8
IE3-KPR 100 LX6	FF 215	160	42	193	196	155	155	140	-	175	63	136	28	28	M10	60	60	8	8
IE3-KPR 100 L4	FF 215	160	42	193	196	155	155	140	-	175	63	166	28	28	M10	60	60	8	8
IE3-KPR 100 LZ4	FF 215	160	42	192	196	155	155	140	-	175	63	206	28	28	M10	60	60	8	8
IE3-KPER 112 MX2	FF 215	190	52	225	196	155	155	140	-	180	70	126	28	28	M10	60	60	8	8
IE3-KPER 112 MV6	FF 215	190	52	225	196	155	155	140	-	180	70	159	28	28	M10	60	60	8	8
IE3-W41R 112 M2	FF 215	190	45	226	217	189	189	140	42	172	70	192	28	28	M10	60	60	8	8
IE3-W41R 112 M4	FF 215	190	45	226	217	189	189	140	42	172	70	242	28	28	M10	60	60	8	8
IE3-W41R 112 M6	FF 215	190	45	226	217	189	189	140	42	172	70	192	28	28	M10	60	60	8	8
IE3-W41R 132 S2	FF 265	216	50	256	217	189	189	140	55	180	89	173	38	32	M12	80	80	10	10
IE3-W41R 132 SX2	FF 265	216	50	256	258	210	210	140	47	180	89	176	38	32	M12	80	80	10	10
IE3-W41R 132 S4	FF 265	216	50	256	258	210	210	140	47	180	89	186	38	32	M12	80	80	10	10
IE3-W41R 132 M4	FF 265	216	50	256	258	210	210	178	47	218	89	236	38	38	M12	80	80	10	10
IE3-W41R 132 S6	FF 265	216	50	256	217	189	189	140	55	180	89	223	38	32	M12	80	80	10	10
IE3-W41R 132 M6	FF 265	216	50	256	258	210	210	178	55	218	89	138	38	32	M12	80	80	10	10
IE3-W41R 132 MX6	FF 265	216	50	256	258	210	210	178	55	218	89	236	38	38	M12	80	80	10	10
IE3-W41R 132 S8	FF 265	216	50	256	258	210	210	140	55	180	89	176	38	32	M12	80	80	10	10
IE3-W41R 132 M8	FF 265	216	50	256	258	210	210	178	55	218	89	138	38	32	M12	80	80	10	10
IE3-W41R 160 M2	FF 300	254	55	296	313	249	275	210	56	257	108	148	42	42	M16	110	110	12	12
IE3-W41R 160 MX2	FF 300	254	55	296	313	249	275	210	56	257	108	186	42	42	M16	110	110	12	12
IE3-W41R 160 L2	FF 300	254	55	296	313	249	275	254	60	301	108	192	42	42	M16	110	110	12	12
IE3-W41R 160 M4	FF 300	254	55	296	313	249	275	210	56	257	108	148	42	42	M16	110	110	12	12
IE3-W41R 160 L4C	FF 300	254	55	296	313	249	275	254	60	301	108	192	42	42	M16	110	110	12	12
IE3-W41R 160 M6	FF 300	254	55	296	313	249	275	210	56	257	108	186	42	42	M16	110	110	12	12
IE3-W41R 160 L6C	FF 300	254	55	296	313	249	275	254	60	301	108	192	42	42	M16	110	110	12	12
IE3-W41R 160 M8	FF 300	254	55	296	313	249	275	210	60	257	108	148	42	42	M16	110	110	12	10
IE3-W41R 160 MX8	FF 300	254	55	296	313	249	275	210	56	257	108	148	42	42	M16	110	110	12	12
IE3-W41R 160 L8	FF 300	254	55	296	313	249	275	254	60	301	108	192	42	42	M16	110	110	12	12
IE3-W41R 180 M2C	FF 300	279	62	328	351	268	294	241	65	288	121	214	48	48	M16	110	110	14	14
IE3-W41R 180 M4	FF 300	279	62	328	351	268	294	241	65	288	121	214	48	48	M16	110	110	14	14
IE3-W41R 180 L4	FF 300	279	62	328	351	268	294	279	65	326	121	226	48	48	M16	110	110	14	14
IE3-W41R 180 L6C	FF 300	279	62	328	351	268	294	279	65	326	121	176	48	48	M16	110	110	14	14
IE3-W41R 180 L8	FF 300	279	62	328	351	268	294	279	65	326	121	226	48	48	M16	110	110	14	14

¹⁾ Centre holes to DIN 332-DS ...

Three-phase motors with squirrel-cage rotor for operation in Zone 2 according to EN 60079-15 (EN 60079-7)

Type of explosion protection „n“ (Increased safety „ec“) and and for operation in Zones 21 and 22 according to EN 60079-31, Type of explosion protection – Protection by enclosure „tb, tc“, Premium Efficiency IE3 (VIK Recommendation 1, Three-Phase Asynchronous Motors – Technical Requirements 03.2011)

with surface cooling, type of cooling IC 411
Size 63 to 180

Type of construction IM B35 [IM 2001]

Flange dimensions, see page 10/6

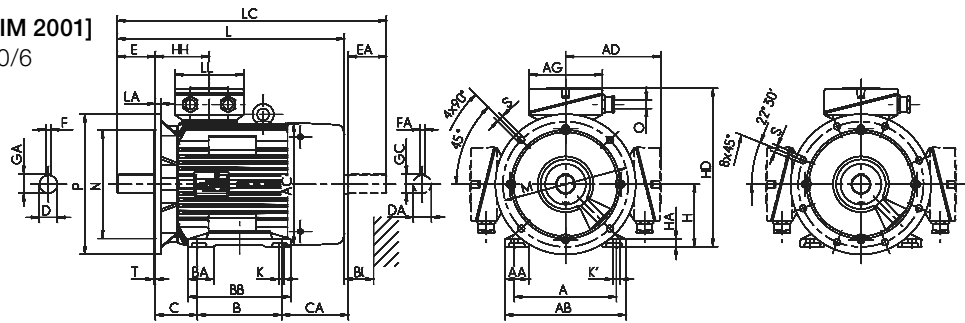

Type designation	GA	GC	H	HA	HD	HD'' ^{*)}	HD	HH	K	K'	L	LC	TB Type	AG	LL	O	TB Type	AG	LL	AH	O	Hole	BI
	t	tl	h	c	p	p	p	A	s	s'	k	k1	Standard	x	z	-	VIK	x	z	-	-	pattern	BI
IE3-KPER 63 G2, 4	13	12.5	63	10	180	***	180	67	8	8	180	205	KA 05-13	92	92	M20 x 1.5	KA 05-13	92	92	-	M25 x 1.5	4L	14
IE3-KPR 63 KY2, G4	13	12.5	63	7.5	186	***	186	70	7	7	200	225	KA 05-13	92	92	M20 x 1.5	KA 05-13	92	92	-	M25 x 1.5	4L	14
E3-KPER 71 G2, KPR 71 G4	16	16	71	11	194	***	194	70	8	8	207	239	KA 05-13	92	92	M20 x 1.5	KA 05-13	92	92	-	M25 x 1.5	4L	14
IE3-KPER 80 K2	22	21.5	80	12	210	***	210	76	10	10	250	293	KA 05-13	92	92	M20 x 1.5	KA 05-13	92	92	-	M25 x 1.5	4L	16
IE3-KPR 80 K2	22	21.5	80	9	218	***	218	79	10	10	267	310	KA 05-13	92	92	M20 x 1.5	KA 05-13	92	92	-	M25 x 1.5	4L	16
IE3-KPR 80 G2, 6, GX4	22	21.5	80	9	218	***	218	79	10	10	289	332	KA 05-13	92	92	M20 x 1.5	KA 05-13	92	92	-	M25 x 1.5	4L	16
IE3-KPR 90 S2	27	27	90	10.5	236	***	236	84	10	10	323	376	KA 05-13	92	92	M25 x 1.5	KA 05-13	92	92	-	M25 x 1.5	4L	18
IE3-KPR 90 S4	27	27	90	10.5	236	***	236	84	10	10	353	406	KA 05-13	92	92	M25 x 1.5	KA 05-13	92	92	-	M25 x 1.5	4L	18
IE3-KPR 90 L2, 6	27	27	90	10.5	236	***	236	84	10	10	353	406	KA 05-13	92	92	M25 x 1.5	KA 05-13	92	92	-	M25 x 1.5	4L	18
IE3-KPR 90 LX4	27	27	90	10.5	236	***	236	84	10	10	378	431	KA 05-13	92	92	M25 x 1.5	KA 05-13	92	92	-	M25 x 1.5	4L	18
IE3-KPR 100 L2	31	31	100	13	255	***	255	86	12	12	358	425	KA 05-13	92	92	M25 x 1.5	KA 05-13	92	92	-	M25 x 1.5	4L	20
IE3-KPR 100 LX6	31	31	100	13	255	***	255	86	12	12	393	459	KA 05-13	92	92	M25 x 1.5	KA 05-13	92	92	-	M25 x 1.5	4L	20
IE3-KPR 100 L4	31	31	100	13	255	***	255	86	12	12	423	489	KA 05-13	92	92	M25 x 1.5	KA 05-13	92	92	-	M25 x 1.5	4L	20
IE3-KPR 100 LZ4	31	31	100	13	255	***	255	86	12	12	463	529	KA 05-13	92	92	M25 x 1.5	KA 05-13	92	92	-	M25 x 1.5	4L	20
IE3-KPER 112 MX2	31	31	112	18	267	***	267	86	12	12	392	459	KA 05-13	92	92	M25 x 1.5	KA 05-13	92	92	-	M25 x 1.5	4L	20
IE3-KPER 112 MV6	31	31	112	18	267	***	267	86	12	12	423	489	KA 05-13	92	92	M25 x 1.5	KA 05-13	92	92	-	M25 x 1.5	4L	20
IE3-W41R 112 M2	31	31	112	15	300	***	300	108	12	12	459	522	25 A	143	134	M32 x 1.5	25 AV	143	134	-	M32 x 1.5	4L	35
IE3-W41R 112 M4	31	31	112	15	300	***	300	108	12	12	509	572	25 A	143	134	M32 x 1.5	25 AV	143	134	-	M32 x 1.5	4L	35
IE3-W41R 112 M6	31	31	112	15	300	***	300	108	12	12	459	522	25 A	143	134	M32 x 1.5	25 AV	143	134	-	M32 x 1.5	4L	35
IE3-W41R 132 S2	41	35	132	16	320	***	320	108	12	12	479	562	25 A	143	134	M32 x 1.5	25 AV	143	134	-	M32 x 1.5	4L	35
IE3-W41R 132 Sx2	41	41	132	15	341	***	341	114	12	12	481	565	25 A	143	134	M32 x 1.5	25 AV	143	134	-	M32 x 1.5	4L	35
IE3-W41R 132 S4	41	41	132	15	341	***	341	114	12	12	529	613	25 A	143	134	M32 x 1.5	25 AV	143	134	-	M32 x 1.5	4L	35
IE3-W41R 132 M4	41	41	132	15	341	***	341	114	12	12	579	663	25 A	143	134	M32 x 1.5	25 AV	143	134	-	M32 x 1.5	4L	35
IE3-W41R 132 S6	41	35	132	16	320	***	320	108	12	12	529	612	25 A	143	134	M32 x 1.5	25 AV	143	134	-	M32 x 1.5	4L	35
IE3-W41R 132 M6	41	41	132	16	341	***	341	114	12	12	481	565	25 A	143	134	M32 x 1.5	25 AV	143	134	-	M32 x 1.5	4L	35
IE3-W41R 132 Mx6	41	41	132	15	341	***	341	114	12	12	579	663	25 A	143	134	M32 x 1.5	25 AV	143	134	-	M32 x 1.5	4L	35
IE3-W41R 132 S8	41	35	132	16	341	***	341	114	12	12	481	565	25 A	143	134	M32 x 1.5	25 AV	143	134	-	M32 x 1.5	4L	35
IE3-W41R 132 M8	41	41	132	16	341	***	341	114	12	12	481	565	25 A	143	134	M32 x 1.5	25 AV	143	134	-	M32 x 1.5	4L	35
IE3-W41R 160 M2	45	45	160	18	409	***	435	138	15	20	571	686	63 A	184	172	M40 x 1.5	100/63 AV	223	214	-	M40 x 1.5	4L	35
IE3-W41R 160 Mx2	45	45	160	18	409	***	435	138	15	20	609	724	63 A	184	172	M40 x 1.5	100/63 AV	223	214	-	M40 x 1.5	4L	35
IE3-W41R 160 L2	45	45	160	18	409	***	435	138	15	20	659	774	63 A	184	172	M40 x 1.5	100/63 AV	223	214	-	M40 x 1.5	4L	35
IE3-W41R 160 M4	45	45	160	18	409	***	435	138	15	20	571	686	63 A	184	172	M40 x 1.5	100/63 AV	223	214	-	M40 x 1.5	4L	35
IE3-W41R 160 L4C	45	45	160	18	409	***	435	138	15	20	659	774	63 A	184	172	M40 x 1.5	100/63 AV	223	214	-	M40 x 1.5	4L	35
IE3-W41R 160 M6	45	45	160	18	409	***	435	138	15	20	609	724	63 A	184	172	M40 x 1.5	100/63 AV	223	214	-	M40 x 1.5	4L	35
IE3-W41R 160 L6C	45	45	160	18	409	***	435	138	15	20	659	774	63 A	184	172	M40 x 1.5	100/63 AV	223	214	-	M40 x 1.5	4L	35
IE3-W41R 160 M8	45	45	160	18	409	***	435	138	15	15	571	724	63 A	184	172	M40 x 1.5	100/63 AV	223	214	-	M40 x 1.5	4L	35
IE3-W41R 160 Mx8	45	45	160	18	409	***	435	138	15	20	571	724	63 A	184	172	M40 x 1.5	100/63 AV	223	214	-	M40 x 1.5	4L	35
IE3-W41R 160 L8	45	45	160	18	409	***	435	138	15	20	659	774	63 A	184	172	M40 x 1.5	100/63 AV	223	214	-	M40 x 1.5	4L	35
IE3-W41R 180 M2C	51.5	51.5	180	20	450	***	476	147	15	20	680	796	63 A	184	172	M40 x 1.5	100/63 AV	223	214	-	M40 x 1.5	4L	35
IE3-W41R 180 M4	51.5	51.5	180	20	450	***	476	147	15	20	680	796	63 A	184	172	M40 x 1.5	100/63 AV	223	214	-	M40 x 1.5	4L	35
IE3-W41R 180 L4	51.5	51.5	180	20	450	***	476	147	15	20	730	846	63 A	184	172	M40 x 1.5	100/63 AV	223	214	-	M40 x 1.5	4L	35
IE3-W41R 180 L6C	51.5	51.5	180	20	450	***	476	147	15	20	680	796	63 A	184	172	M40 x 1.5	100/63 AV	223	214	-	M40 x 1.5	4L	35
IE3-W41R 180 L8	51.5	51.5	180	20	450	***	476	147	15	20	680	796	63 A	184	172	M40 x 1.5	100/63 AV	223	214	-	M40 x 1.5	4L	35

^{*)} Terminal box left/right
^{**) upon request}

Three-phase motors with squirrel-cage rotor for operation in Zone 2 according to EN 60079-15 (EN 60079-7)

Type of explosion protection „n“ (Increased safety „ec“) and for operation in Zones 21 and 22 according to EN 60079-31, Type of explosion protection – Protection by enclosure „tb, tc“, Premium Efficiency IE3 (VIK Recommendation 1, Three-Phase Asynchronous Motors – Technical Requirements 03.2011)

with surface cooling, type of cooling IC 411
Size 200 to 280

Type of construction IM B3 [IM 1001]

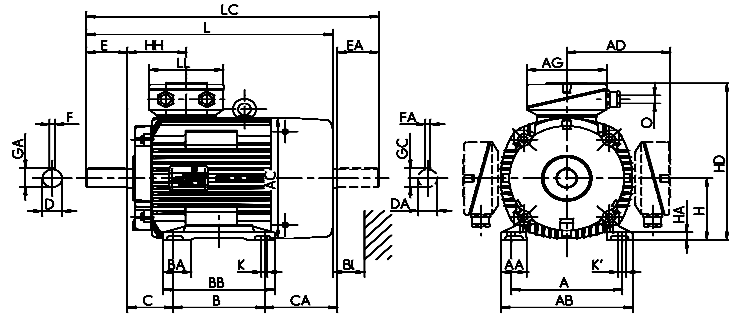

Type designation	Flange size	A	AA	AB	AC	AD	AD VIK	B	BA	BB	C	CA	D	DA	DB ¹⁾	E	EA	F	FA
		b	n	f	g	g1	g1	a	m	e	w1	w2	d	d1		l	l1	u	u1
IE3-W41R 200 L2	FF 350	318	70	372	390	313	378	305	70	360	133	233	55	55	M20	110	110	16	16
IE3-W41R 200 LX2C	FF 350	318	70	372	390	313	378	305	70	360	133	233	55	55	M20	110	110	16	16
IE3-W41R 200 L4C	FF 350	318	70	372	390	313	378	305	70	360	133	233	55	55	M20	110	110	16	16
IE3-W41R 200 L6	FF 350	318	70	372	390	313	378	305	70	360	133	233	55	55	M20	110	110	16	16
IE3-W41R 200 LX6C	FF 350	318	70	372	390	313	378	305	70	360	133	233	55	55	M20	110	110	16	16
IE3-W41R 200 L8	FF 350	318	70	372	351	268	294	305	70	360	133	188	55	48	M20	110	110	16	14
IE3-W41R 225 M2	FF 400	356	75	413	440	337	406	311	75	368	149	267	55	55	M20	110	110	16	16
IE3-W41R 225 S4C	FF 400	356	75	413	390	313	378	286	75	343	149	286	60	55	M20	140	110	18	16
IE3-W41R 225 M4	FF 400	356	75	413	440	337	406	311	75	368	149	267	60	55	M20	140	110	18	16
IE3-W41R 225 M6	FF 400	356	75	413	440	337	406	311	75	368	149	267	60	55	M20	140	110	18	16
IE3-W41R 225 S8	FF 400	356	75	413	390	313	378	286	75	343	149	236	60	55	M20	140	110	18	16
IE3-W41R 225 M8	FF 400	356	75	413	440	337	406	311	75	368	149	267	60	55	M20	140	110	18	16
IE3-W41R 250 M2	FF 500	406	84	469	490	399	403	349	84	374	168	275	60	55	M20	140	110	18	16
IE3-W41R 250 M4	FF 500	406	84	469	490	399	403	349	84	412	168	275	65	55	M20	140	110	18	16
IE3-W41R 250 M6	FF 500	406	84	469	490	399	403	349	84	412	168	275	65	55	M20	140	110	18	16
IE3-W41R 250 M8	FF 500	406	84	471	440	399	403	349	84	412	168	260	65	55	M20	140	110	18	16
IE3-W41R 280 S2	FF 500	457	94	522	490	399	403	368	96	431	190	234	65	65	M20	140	140	18	18
IE3-W41R 280 M2	FF 500	457	94	522	490	399	403	419	96	482	190	234	65	65	M20	140	140	18	18
IE3-W41R 280 S4	FF 500	457	94	522	490	399	403	368	96	431	190	234	75	65	M20	140	140	20	18
IE3-W41R 280 M4	FF 500	457	94	522	550	427	403	419	94	482	190	384	75	65	M20	140	140	20	18
IE3-W41R 280 S6	FF 500	457	94	522	550	427	403	368	94	431	190	380	75	65	M20	140	140	20	18
IE3-W41R 280 M6	FF 500	457	94	522	550	427	403	419	94	482	190	384	75	65	M20	140	140	20	18
IE3-W41R 280 S8	FF 500	457	94	522	550	399	403	368	94	431	190	380	75	65	M20	140	140	20	18
IE3-W41R 280 M8	FF 500	457	94	522	550	427	403	419	94	482	190	384	75	65	M20	140	140	20	18

¹⁾ Centre holes to DIN 332-DS ...

Three-phase motors with squirrel-cage rotor for operation in Zone 2 according to EN 60079-15 (EN 60079-7)

Type of explosion protection „n“ (Increased safety „ec“) and and for operation in Zones 21 and 22 according to EN 60079-31, Type of explosion protection – Protection by enclosure „tb, tc“, Premium Efficiency IE3 (VIK Recommendation 1, Three-Phase Asynchronous Motors – Technical Requirements 03.2011)

fmit Oberflächenkühlung, Kühlart IC 411
Size 200 to 280

Type of construction IM B35 [IM 2001]
Flange dimensions, see page 10/6

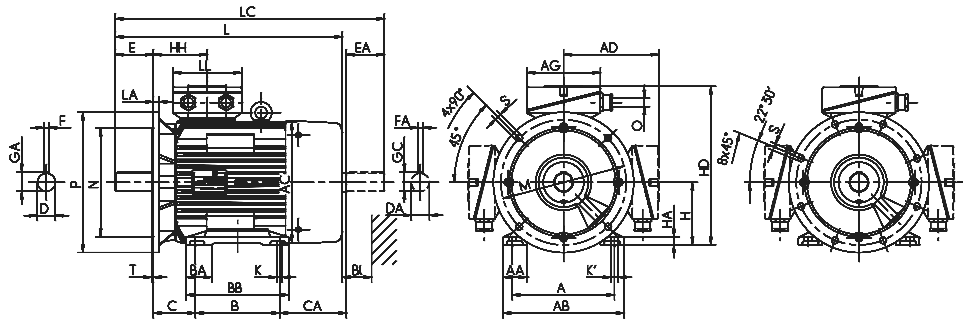

Type designation	GA	GC	H	HA	HD	HD ^{**)}	HD VIK	HH	K	K'	L	LC	TB Type Ex e IIC	AG	LL	O	TB Type Ex e IIC	AG LL	AH	O	Hole pattern	BI	
	t	t1	h	c	p	p	p	A	s	s'	k	k1	Standard	x	z	-	VIK	x	z	-	-	-	-
IE3-W41R 200 L2	59	59	200	22	513	***)	578	168	19	25	767	891	100 A	222	214	M50 x 1.5	200 A-SB	335	270	200	M50 x 1.5	4L	40
IE3-W41R 200 Lx2C	59	59	200	22	513	***)	578	168	19	25	767	891	100 A	222	214	M50 x 1.5	200 A-SB	335	270	200	M50 x 1.5	4L	40
IE3-W41R 200 L4C	59	59	200	22	513	***)	578	168	19	25	767	891	100 A	222	214	M50 x 1.5	200 A-SB	335	270	200	M50 x 1.5	4L	35
IE3-W41R 200 L6	59	59	200	22	513	***)	578	168	19	25	767	891	100 A	222	214	M50 x 1.5	200 A-SB	335	270	200	M50 x 1.5	4L	35
IE3-W41R 200 Lx6C	59	59	200	22	513	***)	578	168	19	25	767	891	100 A	222	214	M50 x 1.5	200 A-SB	335	270	200	M50 x 1.5	4L	35
IE3-W41R 200 L8	59	51.5	200	22	468	***)	494	147	19	25	730	846	63 A	184	172	M50 x 1.5	100/63 AV	223	214	200	M50 x 1.5	4L	35
IE3-W41R 225 M2	59	59	225	25	562	***)	631	177	19	25	832	947	100 A	222	214	M50 x 1.5	200 A-SB	335	270	200	M50 x 1.5	8L	45
IE3-W41R 225 S4C	64	59	225	25	540	***)	605	168	19	25	847	971	100 A	222	214	M50 x 1.5	200 A-SB	335	270	200	M50 x 1.5	8L	40
IE3-W41R 225 M4	64	59	225	25	562	***)	631	177	19	25	912	1027	100 A	222	214	M50 x 1.5	200 A-SB	335	270	200	M50 x 1.5	8L	45
IE3-W41R 225 M6	64	59	225	25	562	***)	631	177	19	25	912	1027	100 A	222	214	M50 x 1.5	200 A-SB	335	270	200	M50 x 1.5	8L	45
IE3-W41R 225 S8	64	59	225	25	540	***)	605	168	19	25	797	921	100 A	222	214	M50 x 1.5	200 A-SB	335	270	200	M50 x 1.5	8L	40
IE3-W41R 225 M8	64	59	225	25	562	***)	631	177	19	25	862	977	100 A	222	214	M50 x 1.5	200 A-SB	335	270	200	M50 x 1.5	8L	45
IE3-W41R 250 M2	64	59	250	28	649	***)	653	206	24	30	924	1072	200 A	290	252	M63 x 1.5	200 A-SB	335	270	200	M63 x 1.5	8L	55
IE3-W41R 250 M4	69	59	250	28	649	***)	653	206	24	30	924	1072	200 A	290	252	M63 x 1.5	200 A-SB	335	270	200	M63 x 1.5	8L	50
IE3-W41R 250 M6	69	59	250	28	649	***)	653	206	24	30	924	1072	200 A	290	252	M63 x 1.5	200 A-SB	335	270	200	M63 x 1.5	8L	50
IE3-W41R 250 M8	69	59	250	28	619	***)	653	177	24	30	912	1112	200 A	290	252	M63 x 1.5	200 A-SB	335	270	200	M63 x 1.5	8L	50
IE3-W41R 280 S2	69	69	280	32	649	***)	653	206	24	30	924	1072	200 A	290	252	M63 x 1.5	200 A-SB	335	270	200	M63 x 1.5	8L	55
IE3-W41R 280 M2	69	69	280	32	677	***)	677	206	24	30	970	1118	200 A	290	252	M63 x 1.5	200 A-SB	335	270	200	M63 x 1.5	8L	55
IE3-W41R 280 S4	79.5	69	280	32	649	***)	653	206	24	30	970	1118	200 A	290	252	M63 x 1.5	200 A-SB	335	270	200	M63 x 1.5	8L	50
IE3-W41R 280 M4	79.5	69	280	40	677	***)	677	211	24	30	1105	1273	200 A	290	252	M63 x 1.5	200 A-SB	335	270	200	M63 x 1.5	8L	55
IE3-W41R 280 S6	79.5	69	280	40	677	***)	677	211	24	30	1050	1218	200 A	290	252	M63 x 1.5	200 A-SB	335	270	200	M63 x 1.5	8L	55
IE3-W41R 280 M6	79.5	69	280	40	677	***)	677	211	24	30	1105	1273	200 A	290	252	M63 x 1.5	200 A-SB	335	270	200	M63 x 1.5	8L	55
IE3-W41R 280 S8	79.5	69	280	40	649	***)	653	211	24	30	1050	1218	200 A	290	252	M63 x 1.5	200 A-SB	335	270	200	M63 x 1.5	8L	55
IE3-W41R 280 M8	79.5	69	280	40	677	***)	677	211	24	30	1105	1273	200 A	290	252	M63 x 1.5	200 A-SB	335	270	200	M63 x 1.5	8L	55

^{**)} Terminal box left/right
^{**)} upon request

Three-phase motors with squirrel-cage rotor for operation in Zone 2 according to EN 60079-15 (EN 60079-7)

Type of explosion protection „n“ (Increased safety „ec“) and and for operation in Zones 21 and 22 according to EN 60079-31, Type of explosion protection – Protection by enclosure „tb, tc“, Premium Efficiency IE3 (VIK Recommendation 1, Three-Phase Asynchronous Motors – Technical Requirements 03.2011)

with surface cooling, type of cooling IC 411
Size 315

Type of construction IM B3 [IM 1001]

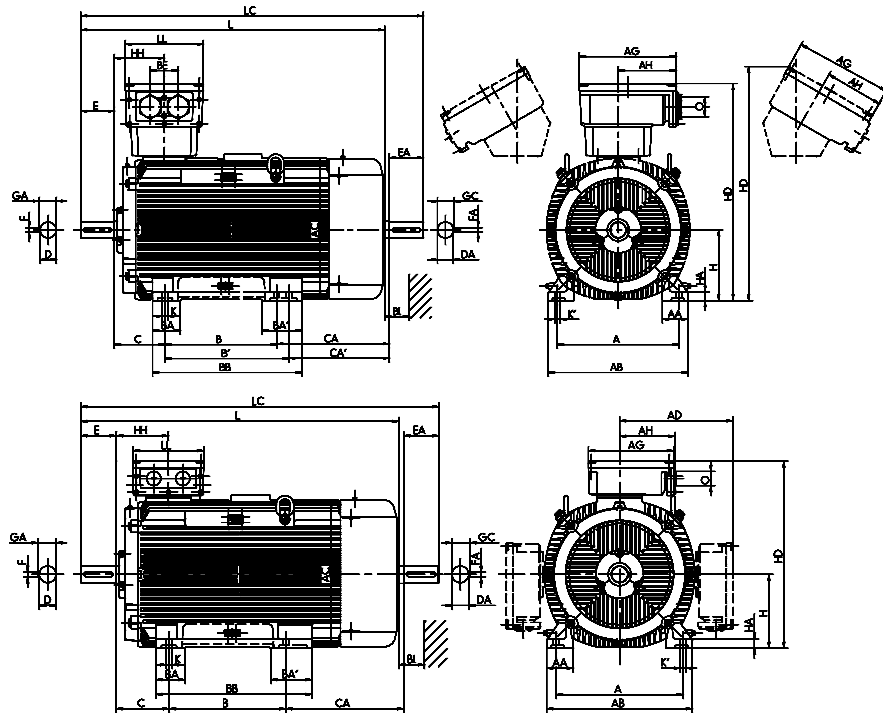

Type designation	Flange size	A	AA	AB	AC	AD	AD VIK	B	BA	BA'	BB	C	CA	D	DA	DB ¹⁾	E	EA	F	FA
		b	n	f	g	g1	g1	a	m	m1	e	w1	w2	d	d1		l	l1	u	u1
IE3-W41R 315 S2	FF 600	508	126	590	550	460	460	406	120	-	503	216	316	65	65	M20	140	140	18	18
IE3-W41R 315 M2	FF 600	508	126	590	550	460	460	457	120	150	554	216	320	65	65	M20	140	140	18	18
IE3-W41R 315 MX2	FF 600	508	110	590	610	681	681	457	120	150	554	216	495	65	65	M20	140	140	18	18
IE3-W41R 315 MY2	FF 600	508	110	590	610	681	681	457	120	-	573	216	495	65	65	M20	140	140	18	18
IE3-W41R 315 L2	FF 600	508	110	590	610	681	681	508	120	-	624	216	564	65	65	M20	140	140	18	18
IE3-W41R 315 LX2	FF 600	508	110	590	610	681	681	508	120	-	624	216	684	65	65	M20	140	140	18	18
IE3-W41R 315 S4	FF 600	508	126	590	550	460	460	406	120	150	503	216	316	80	70	M20	170	140	22	20
IE3-W41R 315 M4	FF 600	508	126	590	550	460	460	457	120	150	554	216	320	80	70	M20	170	140	22	20
IE3-W41R 315 MX4	FF 600	508	110	590	610	681	681	457	120	150	554	216	495	80	70	M20	170	140	22	20
IE3-W41R 315 MY4	FF 600	508	110	590	610	681	681	457	120	-	573	216	495	80	70	M20	170	140	22	20
IE3-W41R 315 L4	FF 600	508	110	590	610	681	681	508	120	-	624	216	564	80	70	M20	170	140	22	20
IE3-W41R 315 LX4	FF 600	508	110	590	610	681	681	508	120	-	624	216	684	80	70	M20	170	140	22	20
IE3-W41R 315 S6	FF 600	508	126	590	550	460	460	406	120	150	554	216	371	80	70	M20	170	140	22	20
IE3-W41R 315 M6	FF 600	508	110	590	610	681	681	457	120	-	573	216	495	80	70	M20	170	140	22	20
IE3-W41R 315 MX6	FF 600	508	110	590	610	681	681	457	120	-	573	216	495	80	70	M20	170	140	22	20
IE3-W41R 315 L6	FF 600	508	110	590	610	681	681	508	120	-	624	216	564	80	70	M20	170	140	22	20
IE3-W41R 315 S8	FF 600	508	126	590	550	460	460	406	120	150	554	216	371	80	70	M20	170	140	22	20
IE3-W41R 315 M8	FF 600	508	110	590	610	681	681	457	120	150	573	216	495	80	70	M20	170	140	22	20
IE3-W41R 315 MX8	FF 600	508	110	590	610	681	681	457	120	-	624	216	564	80	70	M20	170	140	22	20
IE3-W41R 315 L8	FF 600	508	110	590	610	681	681	508	120	-	624	216	564	80	70	M20	170	140	22	20

¹⁾ Centre holes to DIN 332-DS ...

Three-phase motors with squirrel-cage rotor for operation in Zone 2 according to EN 60079-15 (EN 60079-7)

Type of explosion protection „n“ (Increased safety „ec“) and and for operation in Zones 21 and 22 according to EN 60079-31, Type of explosion protection – Protection by enclosure „tb, tc“, Premium Efficiency IE3 (VIK Recommendation 1, Three-Phase Asynchronous Motors – Technical Requirements 03.2011)

with surface cooling, type of cooling IC 411
Size 315

Type of construction IM B35 [IM 1001]

Flange dimensions, see page 10/6

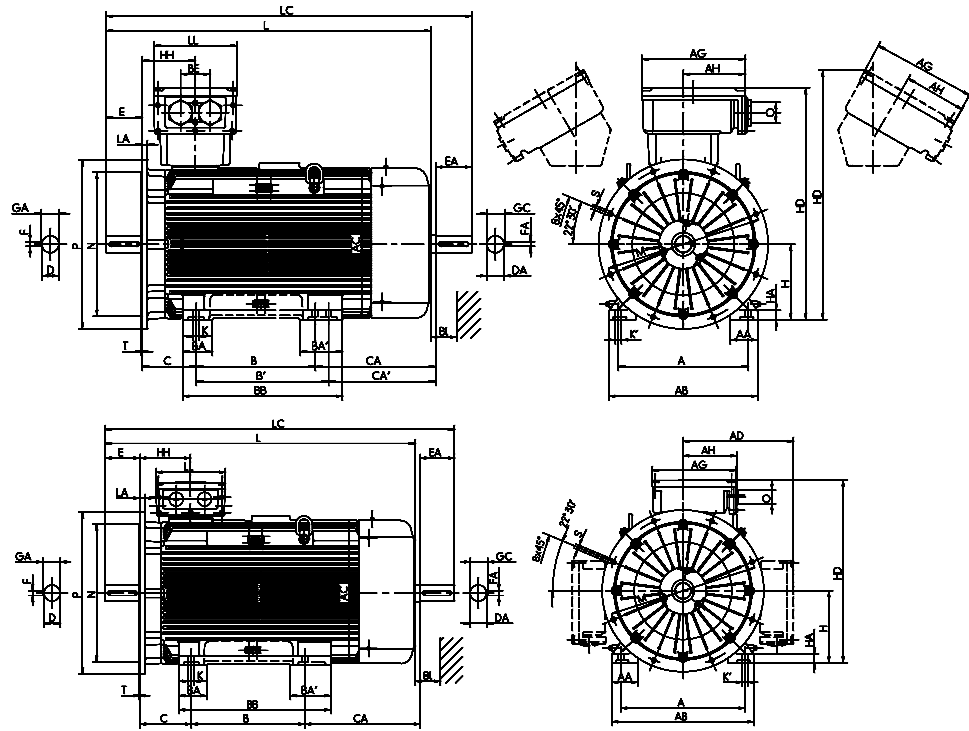

Type designation	GA	GC	H	HA	HD	HD**)	HD	HH	K	K'	L	LC	TB Type	AG	LL	AH	O	TB Type	AG	LL	AH	O	BI
	t	t1	h	c	p	p	p	A	s	s'	k	k1	Standard	x	z	-	-	VIK	x	z	-	-	BI
IE3-W41R 315 S2	69	69	315	44	775	610	775	211	28	35	1050	1218	400 A-SB	415	340	265	M63 x 1.5	400 A-SB	415	340	265	M63 x 1.5	55
IE3-W41R 315 M2	69	69	315	44	775	610	775	211	28	35	1105	1273	400 A-SB	415	340	265	M63 x 1.5	400 A-SB	415	340	265	M63 x 1.5	55
IE3-W41R 315 Mx2	69	69	315	44	996	628	996	230	28	35	1200	1378	630 A	415	340	265	M63 x 1.5	630 A	496	390	301	M63 x 1.5	55
IE3-W41R 315 MY2	69	69	315	44	996	628	996	230	28	35	1270	1448	630 A	496	390	301	M63 x 1.5	630 A	496	390	301	M63 x 1.5	55
IE3-W41R 315 L2	69	69	315	44	996	628	996	230	28	35	1390	1568	630 A	496	390	301	M63 x 1.5	630 A	496	390	301	M63 x 1.5	55
IE3-W41R 315 Lx2	69	69	315	44	996	628	996	230	28	35	1510	1688	630 A	496	390	301	M63 x 1.5	630 A	496	390	301	M63 x 1.5	55
IE3-W41R 315 S4	85	74.5	315	44	775	610	775	211	28	35	1080	1248	400 A-SB	415	340	265	M63 x 1.5	400 A-SB	415	340	265	M63 x 1.5	55
IE3-W41R 315 M4	85	74.5	315	44	775	610	775	211	28	35	1135	1303	400 A-SB	415	340	265	M63 x 1.5	400 A-SB	415	340	265	M63 x 1.5	55
IE3-W41R 315 Mx4	85	74.5	315	44	996	628	996	230	28	35	1230	1408	630 A	415	340	265	M63 x 1.5	630 A	496	390	301	M63 x 1.5	55
IE3-W41R 315 MY4	85	74.5	315	44	996	628	996	230	28	35	1300	1478	630 A	496	390	301	M63 x 1.5	630 A	496	390	301	M63 x 1.5	55
IE3-W41R 315 L4	85	74.5	315	44	996	628	996	230	28	35	1420	1598	630 A	496	390	301	M63 x 1.5	630 A	496	390	301	M63 x 1.5	55
IE3-W41R 315 Lx4	85	74.5	315	44	996	628	996	230	28	35	1540	1718	630 A	496	390	301	M63 x 1.5	630 A	496	390	301	M63 x 1.5	55
IE3-W41R 315 S6	85	74.5	315	44	775	595	775	211	28	35	1135	1303	400 A-SB	415	340	265	M63 x 1.5	400 A-SB	415	340	265	M63 x 1.5	55
IE3-W41R 315 M6	85	74.5	315	44	996	628	996	230	28	35	1300	1478	630 A	496	390	301	M63 x 1.5	630 A	496	390	301	M63 x 1.5	55
IE3-W41R 315 Mx6	85	74.5	315	44	996	628	996	230	28	35	1300	1478	630 A	496	390	301	M63 x 1.5	630 A	496	390	301	M63 x 1.5	55
IE3-W41R 315 L6	85	74.5	315	44	996	628	996	230	28	35	1420	1598	630 A	496	390	301	M63 x 1.5	630 A	496	390	301	M63 x 1.5	55
IE3-W41R 315 S8	85	74.5	315	44	775	610	775	211	28	35	1135	1303	400 A-SB	415	340	265	M63 x 1.5	400 A-SB	496	390	301	M63 x 1.5	55
IE3-W41R 315 M8	85	74.5	315	44	996	628	996	230	28	35	1300	1478	630 A	496	390	301	M63 x 1.5	630 A	496	390	301	M63 x 1.5	55
IE3-W41R 315 Mx8	85	74.5	315	44	996	628	996	230	28	35	1420	1598	630 A	496	390	301	M63 x 1.5	630 A	496	390	301	M63 x 1.5	55
IE3-W41R 315 L8	85	74.5	315	44	996	628	996	230	28	35	1420	1598	630 A	496	390	301	M63 x 1.5	630 A	496	390	301	M63 x 1.5	55

** Terminal box left/right

Three-phase motors with squirrel-cage rotor for operation in Zone 2 according to EN 60079-15 (EN 60079-7)

Type of explosion protection „n“ (Increased safety „ec“) and and for operation in Zones 21 and 22 according to EN 60079-31, Type of explosion protection – Protection by enclosure „tb, tc“, Premium Efficiency IE3 (VIK Recommendation 1, Three-Phase Asynchronous Motors – Technical Requirements 03.2011)

with surface cooling, type of cooling IC 411
Size 355

Type of construction IM B3 [IM 1001]

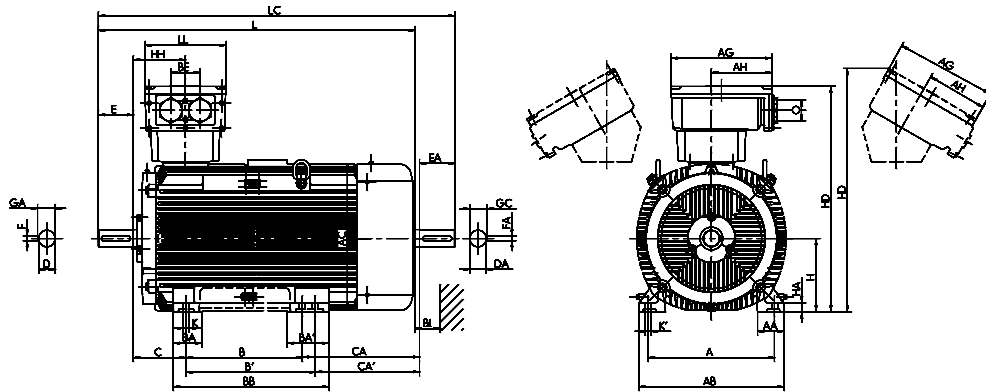

Type designation	Flange size	A	AA	AB	AC	B	BA	BA'	BB	C	CA	D	DA	DB ¹⁾	E	EA	F	FA
		b	n	f	g	a	m	m1	e	w1	w2	d	d1		l	l1	u	u1
IE3-W41R 355 MY2G	FF 740	610	130	700	715	560	140	200	750	254	561	80	80	M20	170	-	22	-
IE3-W41R 355 M2G	FF 740	610	130	700	715	560	140	200	750	254	561	80	80	M20	170	-	22	-
IE3-W41R 355 MX2G	FF 740	610	130	700	715	560	140	200	750	254	681	80	80	M24	170	-	22	-
IE3-W41R 355 L2G	FF 740	610	130	700	715	630	140	200	750	254	611	80	80	M24	170	-	22	-
IE3-W41R 355 MY4	FF 740	610	130	700	715	560	140	200	750	254	561	100	80	M24	210	170	28	22
IE3-W41R 355 M 4	FF 740	610	130	700	715	560	140	200	750	254	561	100	80	M24	210	170	28	22
IE3-W41R 355 MX4	FF 740	610	130	700	715	560	140	200	750	254	681	100	80	M24	210	170	28	22
IE3-W41R 355 L4	FF 740	610	130	700	715	630	140	200	750	254	611	100	80	M24	210	170	28	22
IE3-W41R 355 MY6	FF 740	610	130	700	715	560	140	200	750	254	561	100	80	M24	210	170	28	22
IE3-W41R 355 M6	FF 740	610	130	700	715	560	140	200	750	254	561	100	80	M24	210	170	28	22
IE3-W41R 355 MX6	FF 740	610	130	700	715	560	140	200	750	254	681	100	80	M24	210	170	28	22
IE3-W41R 355 L6	FF 740	610	130	700	715	630	140	200	750	254	611	100	80	M24	210	170	28	22
IE3-W41R 355 LX6	FF 740	610	130	700	715	630	140	200	750	254	611	100	80	M24	210	170	28	22
IE3-W41R 355 MY8	FF 740	610	130	700	715	560	140	200	750	254	561	100	80	M24	210	170	28	22
IE3-W41R 355 M8	FF 740	610	130	700	715	560	140	200	750	254	561	100	80	M24	210	170	28	22
IE3-W41R 355 MX8	FF 740	610	130	700	715	560	140	200	750	254	681	100	80	M24	210	170	28	22
IE3-W41R 355 L8	FF 740	610	130	700	715	630	140	200	750	254	611	100	80	M24	210	170	28	22
IE3-W41R 355 LX8	FF 740	610	130	700	715	630	140	200	750	254	611	100	80	M24	210	170	28	22

¹⁾ Centre holes to DIN 332-DS ...

Three-phase motors with squirrel-cage rotor for operation in Zone 2 according to EN 60079-15 (EN 60079-7)

Type of explosion protection „n“ (Increased safety „ec“) and and for operation in Zones 21 and 22 according to EN 60079-31, Type of explosion protection – Protection by enclosure „tb, tc“, Premium Efficiency IE3 (VIK Recommendation 1, Three-Phase Asynchronous Motors – Technical Requirements 03.2011)

with surface cooling, type of cooling IC 411
Size 355

Type of construction IM B35 [IM 1001]

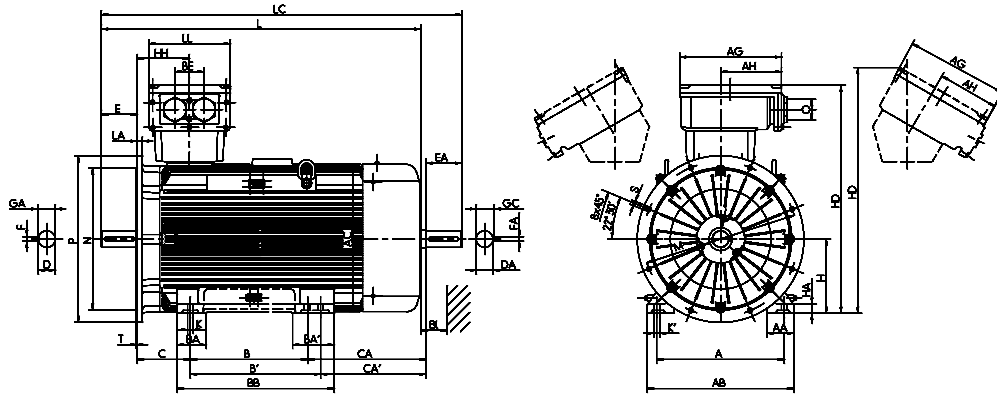

Type designation	GA	GC	H	HA	HD	HD ^{*)}	HD	HH	K	K'	L	LC	TB Type	AG	LL	AH	BE	O	TB Type	AG	LL	AH	BE	O	BI
	t	t1	h	c	p	p	B3, VIK	A	s	s'	k	k1	Standard	x	z	-	-	r	Ex e IIC VIK	x	z	-	-	-	BI
IE3-W41R 355 MY2G	85	-	355	44	1091	1172	1091	250	28	35	1530	-	630 A	496	390	301	140	M75 x 1.5	630 A	496	390	301	140	M75 x 1.5	60
IE3-W41R 355 M2G	85	-	355	44	1091	1172	1091	250	28	35	1530	-	630 A	496	390	301	140	M75 x 1.5	630 A	496	390	301	140	M75 x 1.5	60
IE3-W41R 355 MX2G	85	-	355	44	1091	1172	1091	250	28	35	1730	-	1000 A	615	474	385	200	M75 x 1.5	1000 A	615	474	385	200	M75 x 1.5	60
IE3-W41R 355 L2G	85	-	355	44	1091	1172	1091	250	28	35	1730	-	1000 A	615	474	385	200	M75 x 1.5	1000 A	615	474	385	200	M75 x 1.5	60
IE3-W41R 355 MY4	106	85	355	44	1091	1172	1091	250	28	35	1570	1755	630 A	496	390	301	140	M75 x 1.5	630 A	496	390	301	140	M75 x 1.5	60
IE3-W41R 355 M4	106	85	355	44	1091	1172	1091	250	28	35	1570	1755	630 A	496	390	301	140	M75 x 1.5	630 A	496	390	301	140	M75 x 1.5	60
IE3-W41R 355 MX4	106	85	355	44	1084	1174	1084	250	28	35	1770	1955	1000 A	615	474	385	140	M75 x 1.5	1000 A	615	474	385	140	M75 x 1.5	60
IE3-W41R 355 L4	106	85	355	44	1084	1174	1084	327	28	35	1770	1955	1000 A	615	474	385	200	M75 x 1.5	1000 A	615	474	385	200	M75 x 1.5	60
IE3-W41R 355 MY6	106	85	355	44	1091	1172	1091	250	28	35	1570	1755	630 A	496	390	301	140	M75 x 1.5	630 A	496	390	301	140	M75 x 1.5	60
IE3-W41R 355 M6	106	85	355	44	1091	1172	1091	250	28	35	1570	1755	630 A	496	390	301	140	M75 x 1.5	630 A	496	390	301	140	M75 x 1.5	60
IE3-W41R 355 MX6	106	85	355	44	1091	1172	1091	250	28	35	1770	1955	630 A	496	390	301	140	M75 x 1.5	630 A	496	390	301	140	M75 x 1.5	60
IE3-W41R 355 L6	106	85	355	44	1084	1174	1084	327	28	35	1770	1955	1000 A	615	474	385	200	M75 x 1.5	1000 A	615	474	385	200	M75 x 1.5	60
IE3-W41R 355 LX6	106	85	355	44	1084	1174	1084	327	28	35	1770	1955	1000 A	615	474	385	200	M75 x 1.5	1000 A	615	474	385	200	M75 x 1.5	60
IE3-W41R 355 MY8	106	85	355	44	1091	1172	1091	250	28	35	1570	1755	630 A	496	390	301	140	M75 x 1.5	630 A	496	390	301	140	M75 x 1.5	60
IE3-W41R 355 M8	106	85	355	44	1091	1172	1091	250	28	35	1570	1755	630 A	496	390	301	140	M75 x 1.5	630 A	496	390	301	140	M75 x 1.5	60
IE3-W41R 355 MX8	106	85	355	44	1091	1172	1091	250	28	35	1770	1955	630 A	496	390	301	140	M75 x 1.5	630 A	496	390	301	140	M75 x 1.5	60
IE3-W41R 355 L8	106	85	355	44	1084	1174	1084	327	28	35	1770	1955	1000 A	615	474	385	200	M75 x 1.5	1000 A	615	474	385	200	M75 x 1.5	60
IE3-W41R 355 LX8	106	85	355	44	1084	1174	1084	327	28	35	1770	1955	1000 A	615	474	385	200	M75 x 1.5	1000 A	615	474	385	200	M75 x 1.5	60

^{*)} Terminal box inclined left/right

Three-phase motors with squirrel-cage rotor for operation in Zone 2 according to EN 60079-15 (EN 60079-7)

Type of explosion protection „n“ (Increased safety „ec“) and and for operation in Zones 21 and 22 according to EN 60079-31, Type of explosion protection – Protection by enclosure „tb, tc“, Premium Efficiency IE3 (VIK Recommendation 1, Three-Phase Asynchronous Motors – Technical Requirements 03.2011)

with surface cooling, type of cooling IC 411
Size 63 to 160

Type of construction IM B14 [IM 3601]

Flange dimensions, see page 10/6

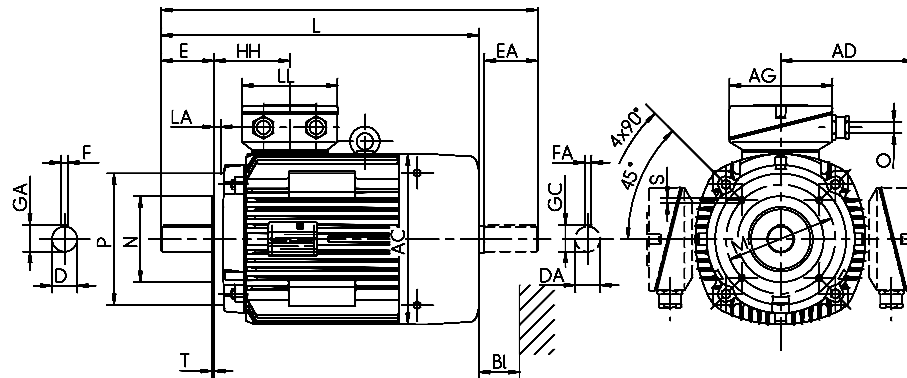

Type designation	Flange size		A	AA	AB	AC	AD	AD	B	BA	BB	C	CA	D	DA	DB ¹⁾	E	EA	F	FA
	small	large	b	n	f	g	g1	g1	a	m	e	w1	w2	d	d1	l	l1	u	u1	
IE3-KPER 63 G2, 4	FT 75	FT 100	100	28	128	109	117	117	80	-	100	40	39	11	11	M4	23	23	4	4
IE3-KPR 63 KY2, G4	FT 75	FT 100	100	21	120	124	123	123	80	-	95	40	59	11	11	M4	23	23	4	4
IE3-KPER 71 G2, KPR 71 G4	FT 85	FT 115	112	32	138	124	123	123	90	-	116	45	44	14	14	M5	30	30	5	5
IE3-KPER 80 K2	FT 100	FT 130	125	38	168	139	111	111	100	-	125	50	63	19	19	M6	40	40	6	6
IE3-KPR 80 K2	FT 100	FT 130	125	27	152	157	138	138	100	-	124	50	80	19	19	M6	40	40	6	6
IE3-KPR 80 G2, 6, GX4	FT 100	FT 130	125	27	152	157	138	138	100	-	146	50	102	19	19	M6	40	40	6	6
IE3-KPR 90 S2	FT 115	FT 130	140	40	178	177	146	146	100	-	130	56	120	24	24	M8	50	50	8	8
IE3-KPR 90 S4	FT 115	FT 130	140	40	178	177	146	146	100	-	130	56	150	24	24	M8	50	50	8	8
IE3-KPR 90 L2, 6	FT 115	FT 130	140	40	178	177	146	146	125	-	155	56	125	24	24	M8	50	50	8	8
IE3-KPR 90 LX4	FT 115	FT 130	140	25	178	177	146	146	125	-	155	56	150	24	24	M8	50	50	8	8
IE3-KPR 100 L2	FT 130	FT 165	160	42	193	196	155	155	140	-	175	63	102	28	28	M10	60	60	8	8
IE3-KPR 100 LX6	FT 130	FT 165	160	42	193	196	155	155	140	-	175	63	136	28	28	M10	60	60	8	8
IE3-KPR 100 L4	FT 130	FT 165	160	42	193	196	155	155	140	-	175	63	166	28	28	M10	60	60	8	8
IE3-KPR 100 LZ4	FT 130	FT 165	160	42	192	196	155	155	140	-	175	63	206	28	28	M10	60	60	8	8
IE3-KPER 112 MX2	FT 130	FT 165	190	52	225	196	155	155	140	-	180	70	126	28	28	M10	60	60	8	8
IE3-KPER 112 MV6	FT 130	FT 165	190	52	225	196	155	155	140	-	180	70	159	28	28	M10	60	60	8	8
IE3-W41R 112 M2	FT 130	FT 165	190	45	226	217	189	189	140	42	172	70	192	28	28	M10	60	60	8	8
IE3-W41R 112 M4	FT 130	FT 165	190	45	226	217	189	189	140	42	172	70	242	28	28	M10	60	60	8	8
IE3-W41R 112 M6	FT 130	FT 165	190	45	226	217	189	189	140	42	172	70	192	28	28	M10	60	60	8	8
IE3-W41R 132 S2	FT 130	FT 165	216	50	256	217	189	189	140	55	180	89	173	38	32	M12	80	80	10	10
IE3-W41R 132 SX2	FT 165	FT 215	216	50	256	258	210	210	140	47	180	89	176	38	32	M12	80	80	10	10
IE3-W41R 132 S4	FT 165	FT 215	216	50	256	258	210	210	140	47	180	89	186	38	32	M12	80	80	10	10
IE3-W41R 132 M4	FT 165	FT 215	216	50	256	258	210	210	178	47	218	89	236	38	38	M12	80	80	10	10
IE3-W41R 132 S6	FT 130	FT 165	216	50	256	217	189	189	140	55	180	89	223	38	32	M12	80	80	10	10
IE3-W41R 132 M6	FT 165	FT 215	216	50	256	258	210	210	178	55	218	89	138	38	32	M12	80	80	10	10
IE3-W41R 132 MX6	FT 165	FT 215	216	50	256	258	210	210	178	47	218	89	236	38	38	M12	80	80	10	10
IE3-W41R 132 S8	FT 130	FT 165	216	50	256	258	210	210	140	55	180	89	223	38	32	M12	80	80	10	10
IE3-W41R 132 M8	FT 165	FT 215	216	50	256	258	210	210	178	55	218	89	138	38	32	M12	80	80	10	10
IE3-W41R 160 M2	FT 215	C300	254	55	296	313	249	275	210	60	257	108	148	42	42	M16	110	110	12	12
IE3-W41R 160 MX2	FT 215	C300	254	55	296	313	249	275	210	56	257	108	186	42	42	M16	110	110	12	12
IE3-W41R 160 L2	FT 215	C300	254	55	296	313	249	275	254	60	301	108	192	42	42	M16	110	110	12	12
IE3-W41R 160 M4	FT 215	C300	254	55	296	313	249	275	210	60	257	108	148	42	42	M16	110	110	12	12
IE3-W41R 160 L4C	FT 215	C300	254	55	296	313	249	275	254	60	301	108	192	42	42	M16	110	110	12	12
IE3-W41R 160 M6	FT 215	C300	254	55	296	313	249	275	210	56	257	108	186	42	42	M16	110	110	12	12
IE3-W41R 160 L6C	FT 215	C300	254	55	296	313	249	275	254	60	301	108	192	42	42	M16	110	110	12	12
IE3-W41R 160 M8	FT 215	C300	254	55	296	313	249	275	210	60	257	108	185	42	42	M16	110	110	12	12
IE3-W41R 160 MX8	FT 215	C300	254	55	296	313	249	275	210	56	257	108	186	42	42	M16	110	110	12	12
IE3-W41R 160 L8	FT 215	C300	254	55	296	313	249	275	254	60	301	108	192	42	42	M16	110	110	12	12

¹⁾ Centre holes to DIN 332-DS ...

Three-phase motors with squirrel-cage rotor for operation in Zone 2 according to EN 60079-15 (EN 60079-7)

Type of explosion protection „n“ (Increased safety „ec“) and for operation in Zones 21 and 22 according to EN 60079-31, Type of explosion protection – Protection by enclosure „tb, tc“, Premium Efficiency IE3 (VIK Recommendation 1, Three-Phase Asynchronous Motors – Technical Requirements 03.2011)

with surface cooling, type of cooling IC 411
Size 63 to 160

Type of construction IM B34 [IM 2101]
Flange dimensions, see page 10/6

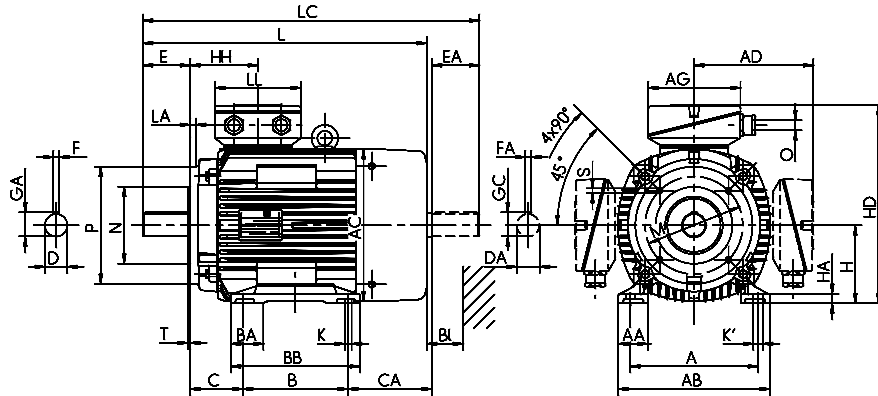

Type designation	GA	GC	H	HA	HD	HD**)	HD	HH	K	K'	L	LC	TB Type	AG	LL	O	TB Type	AG	LL	AH	O	Loch-	BI
	t	t1	h	c	p	p	p	A	s	s'	k	k1	Ex e IIC Standard	x	z	-	Ex e IIC VIK	x	z	-	-	bild	Bl
IE3-KPER 63 G2, 4	13	12.5	63	10	180	***	180	67	8	8	180	205	KA 05-13	92	92	M20 x 1.5	KA 05-13	92	92	-	M25 x 1.5	4L	14
IE3-KPR 63 KY2, G4	13	12.5	63	7.5	186	***	186	70	7	7	200	225	KA 05-13	92	92	M20 x 1.5	KA 05-13	92	92	-	M25 x 1.5	4L	14
IE3-KPER 71 G2, KPR 71 G4	16	16	71	11	194	***	194	70	8	8	207	239	KA 05-13	92	92	M20 x 1.5	KA 05-13	92	92	-	M25 x 1.5	4L	14
IE3-KPER 80 K2	22	21.5	80	12	210	***	210	76	10	10	250	293	KA 05-13	92	92	M20 x 1.5	KA 05-13	92	92	-	M25 x 1.5	4L	16
IE3-KPR 80 K2	22	21.5	80	9	218	***	218	79	10	10	267	310	KA 05-13	92	92	M20 x 1.5	KA 05-13	92	92	-	M25 x 1.5	4L	16
IE3-KPR 80 G2, 6, GX4	22	21.5	80	9	218	***	218	79	10	10	289	332	KA 05-13	92	92	M20 x 1.5	KA 05-13	92	92	-	M25 x 1.5	4L	16
IE3-KPR 90 S2	27	27	90	10.5	236	***	236	84	10	10	323	376	KA 05-13	92	92	M25 x 1.5	KA 05-13	92	92	-	M25 x 1.5	4L	18
IE3-KPR 90 S4	27	27	90	10.5	236	***	236	84	10	10	353	406	KA 05-13	92	92	M25 x 1.5	KA 05-13	92	92	-	M25 x 1.5	4L	18
IE3-KPR 90 L2, 6	27	27	90	10.5	236	***	236	84	10	10	353	406	KA 05-13	92	92	M25 x 1.5	KA 05-13	92	92	-	M25 x 1.5	4L	18
IE3-KPR 90 LX4	27	27	90	10.5	236	***	236	84	10	10	378	431	KA 05-13	92	92	M25 x 1.5	KA 05-13	92	92	-	M25 x 1.5	4L	18
IE3-KPR 100 L2	31	31	100	13	255	***	255	86	12	12	358	425	KA 05-13	92	92	M25 x 1.5	KA 05-13	92	92	-	M25 x 1.5	4L	20
IE3-KPR 100 LX6	31	31	100	13	255	***	255	86	12	12	393	459	KA 05-13	92	92	M25 x 1.5	KA 05-13	92	92	-	M25 x 1.5	4L	20
IE3-KPR 100 L4	31	31	100	13	255	***	255	86	12	12	423	489	KA 05-13	92	92	M25 x 1.5	KA 05-13	92	92	-	M25 x 1.5	4L	20
IE3-KPR 100 LZ4	31	31	100	13	255	***	255	86	12	12	463	529	KA 05-13	92	92	M25 x 1.5	KA 05-13	92	92	-	M25 x 1.5	4L	20
IE3-KPER 112 MX2	31	31	112	18	267	***	267	86	12	12	392	459	KA 05-13	92	92	M25 x 1.5	KA 05-13	92	92	-	M25 x 1.5	4L	20
IE3-KPER 112 MV6	31	31	112	18	267	***	267	86	12	12	423	489	KA 05-13	92	92	M25 x 1.5	KA 05-13	92	92	-	M25 x 1.5	4L	20
IE3-W41R 112 M2	31	31	112	15	300	***	300	108	12	12	459	522	25 A	143	134	M32 x 1.5	25 AV	143	134	-	M32 x 1.5	4L	35
IE3-W41R 112 M4	31	31	112	15	300	***	300	108	12	12	509	572	25 A	143	134	M32 x 1.5	25 AV	143	134	-	M32 x 1.5	4L	35
IE3-W41R 112 M6	31	31	112	15	300	***	300	108	12	12	459	522	25 A	143	134	M32 x 1.5	25 AV	143	134	-	M32 x 1.5	4L	35
IE3-W41R 132 S2	41	35	132	16	320	***	320	108	12	12	479	562	25 A	143	134	M32 x 1.5	25 AV	143	134	-	M32 x 1.5	4L	35
IE3-W41R 132 SX2	41	41	132	15	341	***	341	114	12	12	481	565	25 A	143	134	M32 x 1.5	25 AV	143	134	-	M32 x 1.5	4L	35
IE3-W41R 132 S4	41	41	132	15	341	***	341	114	12	12	529	613	25 A	143	134	M32 x 1.5	25 AV	143	134	-	M32 x 1.5	4L	35
IE3-W41R 132 M4	41	41	132	15	341	***	341	114	12	12	579	663	25 A	143	134	M32 x 1.5	25 AV	143	134	-	M32 x 1.5	4L	35
IE3-W41R 132 S6	41	35	132	16	320	***	320	108	12	12	529	612	25 A	143	134	M32 x 1.5	25 AV	143	134	-	M32 x 1.5	4L	35
IE3-W41R 132 M6	41	35	132	16	341	***	341	114	12	12	481	565	25 A	143	134	M32 x 1.5	25 AV	143	134	-	M32 x 1.5	4L	35
IE3-W41R 132 MX6	41	41	132	15	341	***	341	114	12	12	579	663	25 A	143	134	M32 x 1.5	25 AV	143	134	-	M32 x 1.5	4L	35
IE3-W41R 132 S8	41	35	132	16	341	***	341	114	12	12	481	565	25 A	143	134	M32 x 1.5	25 AV	143	134	-	M32 x 1.5	4L	35
IE3-W41R 132 M8	41	35	132	16	341	***	341	114	12	12	481	565	25 A	143	134	M32 x 1.5	25 AV	143	134	-	M32 x 1.5	4L	35
IE3-W41R 160 M2	45	45	160	18	409	***	435	138	15	20	571	686	63 A	184	172	M40 x 1.5	100/63 AV	223	214	-	M40 x 1.5	4L	35
IE3-W41R 160 MX2	45	45	160	18	409	***	435	138	15	20	609	724	63 A	184	172	M40 x 1.5	100/63 AV	223	214	-	M40 x 1.5	4L	35
IE3-W41R 160 L2	45	45	160	18	409	***	435	138	15	20	659	774	63 A	184	172	M40 x 1.5	100/63 AV	223	214	-	M40 x 1.5	4L	35
IE3-W41R 160 M4	45	45	160	18	409	***	435	138	15	20	571	686	63 A	184	172	M40 x 1.5	100/63 AV	223	214	-	M40 x 1.5	4L	35
IE3-W41R 160 L4C	45	45	160	18	409	***	435	138	15	20	659	774	63 A	184	172	M40 x 1.5	100/63 AV	223	214	-	M40 x 1.5	4L	35
IE3-W41R 160 M6	45	45	160	18	409	***	435	138	15	20	609	724	63 A	184	172	M40 x 1.5	100/63 AV	223	214	-	M40 x 1.5	4L	35
IE3-W41R 160 L6C	45	45	160	18	409	***	435	138	15	20	659	774	63 A	184	172	M40 x 1.5	100/63 AV	223	214	-	M40 x 1.5	4L	35
IE3-W41R 160 M8	45	45	160	18	409	***	435	138	15	20	571	693	63 A	184	172	M40 x 1.5	100/63 AV	223	214	-	M40 x 1.5	4L	35
IE3-W41R 160 MX8	45	45	160	18	409	***	435	138	15	20	571	724	63 A	184	172	M40 x 1.5	100/63 AV	223	214	-	M40 x 1.5	4L	35
IE3-W41R 160 L8	45	45	160	18	409	***	435	138	15	20	659	774	63 A	184	172	M40 x 1.5	100/63 AV	223	214	-	M40 x 1.5	4L	35

** Terminal box left/right
*** upon request

Three-phase motors with squirrel-cage rotor for operation in Zone 2 according to EN 60079-15 (EN 60079-7)

Type of explosion protection „n“ (Increased safety „ec“) and and for operation in Zones 21 and 22 according to EN 60079-31, Type of explosion protection – Protection by enclosure „tb, tc“, Premium Efficiency IE3 (VIK Recommendation 1, Three-Phase Asynchronous Motors – Technical Requirements 03.2011)

with surface cooling, type of cooling IC 411

Size 63 to 280

Type of construction IM B5 [IM 3001], Type of construction IM V1 [IM 3011], Flange dimensions, see page 10/6

Type designation	Flange size	AC	AD	AD	D	DA	DB ¹⁾	E	EA	F	FA	GA	GC	H	HH	L
	g	g1	g1 VIK	d	d1	l	l1	u	u1	t	t1	h	A	k		
IE3-KPER 63 G2, 4	FF 115	109	117	117	11	11	M4	23	23	4	4	13	12.5	63	67	180
IE3-KPR 63 KY2, G4	FF 115	124	123	123	11	11	M4	23	23	4	4	13	12.5	63	70	200
E3-KPER 71 G2, KPR 71 G4	FF 130	124	123	123	14	14	M5	30	30	5	5	16	16	71	70	207
IE3-KPER 80 K2	FF 165	139	111	111	19	19	M6	40	40	6	6	22	21.5	80	76	250
IE3-KPR 80 K2	FF 165	157	138	138	19	19	M6	40	40	6	6	22	21.5	80	79	267
IE3-KPR 80 G2, 6, GX4	FF 165	157	138	138	19	19	M6	40	40	6	6	22	21.5	80	79	289
IE3-KPR 90 S2	FF 165	177	146	146	24	24	M8	50	50	8	8	27	27	90	84	361
IE3-KPR 90 S4	FF 165	177	146	146	24	24	M8	50	50	8	8	27	27	90	84	391
IE3-KPR 90 L2, 6	FF 165	177	146	146	24	24	M8	50	50	8	8	27	27	90	84	391
IE3-KPR 90 LX4	FF 165	177	146	146	24	24	M8	50	50	8	8	27	27	90	84	416
IE3-KPR 100 L2	FF 215	196	155	155	28	28	M10	60	60	8	8	31	31	100	86	358
IE3-KPR 100 LX6	FF 215	196	155	155	28	28	M10	60	60	8	8	31	31	100	86	393
IE3-KPR 100 L4	FF 215	196	155	155	28	28	M10	60	60	8	8	31	31	100	86	423
IE3-KPR 100 LZ4	FF 215	196	155	155	28	28	M10	60	60	8	8	31	31	100	86	463
IE3-KPER 112 MX2	FF 215	196	155	155	28	28	M10	60	60	8	8	31	31	112	86	392
IE3-KPER 112 MV6	FF 215	196	155	155	28	28	M10	60	60	8	8	31	31	112	86	423
IE3-W41R 112 M2	FF 215	217	189	189	28	28	M10	60	60	8	8	31	31	112	108	459
IE3-W41R 112 M4	FF 215	217	189	189	28	28	M10	60	60	8	8	31	31	112	108	509
IE3-W41R 112 M6	FF 215	217	189	189	28	28	M10	60	60	8	8	31	31	112	108	459
IE3-W41R 132 S2	FF 265	217	189	189	38	32	M12	80	80	10	10	41	35	132	108	479
IE3-W41R 132 SX2	FF 265	258	210	210	38	32	M12	80	80	10	10	41	35	132	114	481
IE3-W41R 132 S4	FF 265	258	210	210	38	32	M12	80	80	10	10	41	35	132	114	529
IE3-W41R 132 M4	FF 265	258	210	210	38	38	M12	80	80	10	10	41	41	132	114	579
IE3-W41R 132 S6	FF 265	217	189	189	38	32	M12	80	80	10	10	41	35	132	108	529
IE3-W41R 132 M6	FF 265	258	210	210	38	32	M12	80	80	10	10	41	35	132	114	481
IE3-W41R 132 MX6	FF 265	258	210	210	38	38	M12	80	80	10	10	41	41	132	114	579
IE3-W41R 132 S8	FF 265	258	210	210	38	32	M12	80	80	10	10	41	35	132	114	481
IE3-W41R 132 M8	FF 265	258	210	210	38	32	M12	80	80	10	10	41	35	132	114	481
IE3-W41R 160 M2	FF 300	313	249	275	42	42	M16	110	110	12	12	45	45	160	138	571
IE3-W41R 160 MX2	FF 300	313	249	275	42	42	M16	110	110	12	12	45	45	160	138	609
IE3-W41R 160 L2	FF 300	313	249	275	42	42	M16	110	110	12	12	45	45	160	138	659
IE3-W41R 160 M4	FF 300	313	249	275	42	42	M16	110	110	12	12	45	45	160	138	571
IE3-W41R 160 L4C	FF 300	313	249	275	42	42	M16	110	110	12	12	45	45	160	138	659
IE3-W41R 160 M6	FF 300	313	249	275	42	42	M16	110	110	12	12	45	45	160	138	609
IE3-W41R 160 L6C	FF 300	313	249	275	42	42	M16	110	110	12	12	45	45	160	138	659
IE3-W41R 160 M8	FF 300	313	249	275	42	42	M16	110	80	12	10	45	45	160	138	571
IE3-W41R 160 MX8	FF 300	313	249	275	42	42	M16	110	110	12	12	45	45	160	138	571
IE3-W41R 160 L8	FF 300	313	249	275	42	42	M16	110	110	12	12	45	45	160	138	659
IE3-W41R 180 M2C	FF 300	351	270	294	48	48	M16	110	110	14	14	51.5	51.5	180	147	680
IE3-W41R 180 M4	FF 300	351	270	294	48	48	M16	110	110	14	14	51.5	51.5	180	147	680
IE3-W41R 180 L4	FF 300	351	270	294	48	48	M16	110	110	14	14	51.5	51.5	180	147	730
IE3-W41R 180 L6C	FF 300	351	270	294	48	48	M16	110	110	14	14	51.5	51.5	180	147	680
IE3-W41R 180 L8	FF 300	351	270	294	48	48	M16	110	110	14	14	51.5	51.5	180	147	680
IE3-W41R 200 L2	FF 350	390	313	378	55	55	M20	110	110	16	16	59	59	200	168	767
IE3-W41R 200 LX2C	FF 350	390	313	378	55	55	M20	110	110	16	16	59	59	200	168	767
IE3-W41R 200 L4C	FF 350	390	313	378	55	55	M20	110	110	16	16	59	59	200	168	767
IE3-W41R 200 L6	FF 350	390	313	378	55	55	M20	110	110	16	16	59	59	200	168	767
IE3-W41R 200 LX6C	FF 350	390	313	378	55	55	M20	110	110	16	16	59	59	200	168	767
IE3-W41R 200 L8	FF 350	351	268	294	55	48	M20	110	110	16	14	59	51.5	200	147	730
IE3-W41R 225 M2	FF 400	440	337	406	65	55	M20	110	110	18	16	59	59	225	177	832
IE3-W41R 225 S4C	FF 400	390	315	378	60	55	M20	140	110	18	16	64	59	225	168	847
IE3-W41R 225 M4	FF 400	440	337	406	60	55	M20	140	110	18	16	64	59	225	177	912
IE3-W41R 225 M6	FF 400	440	337	406	60	55	M20	140	110	18	16	64	59	225	177	912
IE3-W41R 225 S8	FF 400	390	315	378	60	55	M20	140	110	18	16	64	59	225	168	797
IE3-W41R 225 M8	FF 400	440	337	406	60	55	M20	140	110	18	16	64	59	225	177	862
IE3-W41R 250 M2	FF 500	490	397	403	60	55	M20	140	110	18	18	64	59	250	206	924
IE3-W41R 250 M4	FF 500	490	397	403	65	55	M20	140	110	18	18	69	59	280	206	924
IE3-W41R 250 M6	FF 500	490	397	403	65	55	M20	140	110	18	16	69	59	250	206	924
IE3-W41R 250 M8	FF 500	440	397	403	65	55	M20	140	110	18	16	69	59	250	206	912
IE3-W41R 280 S2	FF 500	490	367	403	65	65	M20	140	140	18	18	69	69	280	206	924
IE3-W41R 280 M2	FF 500	490	397	403	65	65	M20	140	140	18	18	69	69	280	206	970
IE3-W41R 280 S4	FF 500	490	367	403	75	65	M20	140	140	20	18	79.5	69	280	206	970
IE3-W41R 280 M4	FF 500	550	397	403	75	65	M20	140	140	20	18	79.5	69	280	211	1105
IE3-W41R 280 S6	FF 500	550	367	403	75	65	M20	140	110	20	18	79.5	69	280	211	1050
IE3-W41R 280 M6	FF 500	550	397	403	75	65	M20	140	140	20	18	79.5	69	280	211	1105
IE3-W41R 280 S8	FF 500	550	367	403	75	65	M20	140	110	20	18	79.5	69	280	211	1050
IE3-W41R 280 M8	FF 500	550	397	403	75	65	M20	140	140	20	18	79.5	69	280	211	1105

Low voltage electrical machines

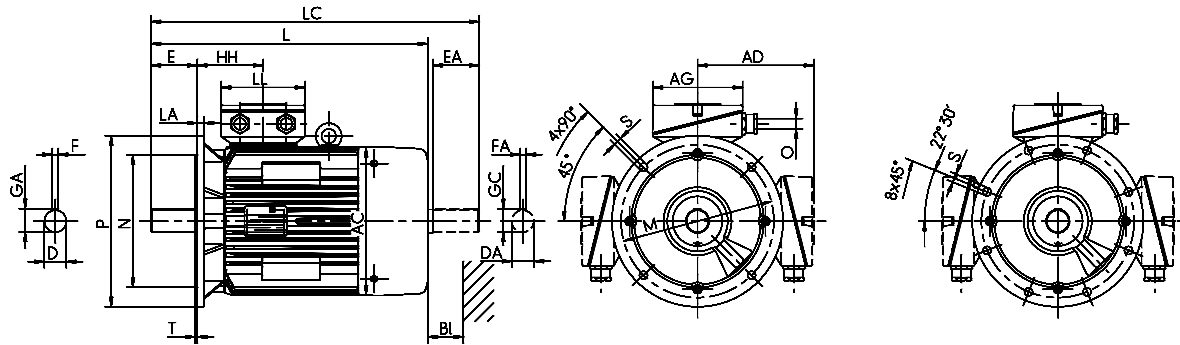

Type designation	L	LC	TB Type Ex e IIC	AG	LL	O	TB Type Ex e IIC	AG	LL	AH	O	Loch- bild	BI
	k IM V1	k1	Standard	x	z	-	VIK	x	z	-	-	-	Bl
IE3-KPER 63 G2, 4	209	205	KA 05-13	92	92	M20 x 1.5	KA 05-13	92	92	-	M25 x 1.5	4L	14
IE3-KPR 63 KY2, G4	229	225	KA 05-13	92	92	M20 x 1.5	KA 05-13	92	92	-	M25 x 1.5	4L	14
E3-KPER 71 G2, KPR 71 G4	236	239	KA 05-13	92	92	M20 x 1.5	KA 05-13	92	92	-	M25 x 1.5	4L	14
IE3-KPER 80 K2	279	293	KA 05-13	92	92	M20 x 1.5	KA 05-13	92	92	-	M25 x 1.5	4L	16
IE3-KPR 80 K2	296	310	KA 05-13	92	92	M20 x 1.5	KA 05-13	92	92	-	M25 x 1.5	4L	16
IE3-KPR 80 G2, 6, GX4	318	332	KA 05-13	92	92	M20 x 1.5	KA 05-13	92	92	-	M25 x 1.5	4L	16
IE3-KPR 90 S2	352	415	KA 05-13	92	92	M25 x 1.5	KA 05-13	92	92	-	M25 x 1.5	4L	18
IE3-KPR 90 S4	382	445	KA 05-13	92	92	M25 x 1.5	KA 05-13	92	92	-	M25 x 1.5	4L	18
IE3-KPR 90 L2, 6	382	445	KA 05-13	92	92	M25 x 1.5	KA 05-13	92	92	-	M25 x 1.5	4L	18
IE3-KPR 90 LX4	407	470	KA 05-13	92	92	M25 x 1.5	KA 05-13	92	92	-	M25 x 1.5	4L	18
IE3-KPR 100 L2	387	425	KA 05-13	92	92	M25 x 1.5	KA 05-13	92	92	-	M25 x 1.5	4L	20
IE3-KPR 100 LX6	422	459	KA 05-13	92	92	M25 x 1.5	KA 05-13	92	92	-	M25 x 1.5	4L	20
IE3-KPR 100 L4	452	489	KA 05-13	92	92	M25 x 1.5	KA 05-13	92	92	-	M25 x 1.5	4L	20
IE3-KPR 100 LZ4	492	529	KA 05-13	92	92	M25 x 1.5	KA 05-13	92	92	-	M25 x 1.5	4L	20
IE3-KPER 112 MX2	421	459	KA 05-13	92	92	M25 x 1.5	KA 05-13	92	92	-	M25 x 1.5	4L	20
IE3-KPER 112 MV6	452	489	KA 05-13	92	92	M25 x 1.5	KA 05-13	92	92	-	M25 x 1.5	4L	20
IE3-W41R 112 M2	499	522	25 A	143	134	M32 x 1.5	25 AV	143	134	-	M32 x 1.5	4L	35
IE3-W41R 112 M4	549	572	25 A	143	134	M32 x 1.5	25 AV	143	134	-	M32 x 1.5	4L	35
IE3-W41R 112 M6	499	522	25 A	143	134	M32 x 1.5	25 AV	143	134	-	M32 x 1.5	4L	35
IE3-W41R 132 S2	519	562	25 A	143	134	M32 x 1.5	25 AV	143	134	-	M32 x 1.5	4L	35
IE3-W41R 132 SX2	521	565	25 A	143	134	M32 x 1.5	25 AV	143	134	-	M32 x 1.5	4L	35
IE3-W41R 132 S4	569	613	25 A	143	134	M32 x 1.5	25 AV	143	134	-	M32 x 1.5	4L	35
IE3-W41R 132 M4	619	663	25 A	143	134	M32 x 1.5	25 AV	143	134	-	M32 x 1.5	4L	35
IE3-W41R 132 S6	569	612	25 A	143	134	M32 x 1.5	25 AV	143	134	-	M32 x 1.5	4L	35
IE3-W41R 132 M6	521	565	25 A	143	134	M32 x 1.5	25 AV	143	134	-	M32 x 1.5	4L	35
IE3-W41R 132 MX6	619	663	25 A	143	134	M32 x 1.5	25 AV	143	134	-	M32 x 1.5	4L	35
IE3-W41R 132 S8	521	565	25 A	143	134	M32 x 1.5	25 AV	143	134	-	M32 x 1.5	4L	35
IE3-W41R 132 M8	521	565	25 A	143	134	M32 x 1.5	25 AV	143	134	-	M32 x 1.5	4L	35
IE3-W41R 160 M2	611	686	63 A	184	172	M40 x 1.5	100/63 AV	223	214	-	M40 x 1.5	4L	35
IE3-W41R 160 MX2	649	724	63 A	184	172	M40 x 1.5	100/63 AV	223	214	-	M40 x 1.5	4L	35
IE3-W41R 160 L2	699	774	63 A	184	172	M40 x 1.5	100/63 AV	223	214	-	M40 x 1.5	4L	35
IE3-W41R 160 M4	611	686	63 A	184	172	M40 x 1.5	100/63 AV	223	214	-	M40 x 1.5	4L	35
IE3-W41R 160 L4C	699	774	63 A	184	172	M40 x 1.5	100/63 AV	223	214	-	M40 x 1.5	4L	35
IE3-W41R 160 M6	649	724	63 A	184	172	M40 x 1.5	100/63 AV	223	214	-	M40 x 1.5	4L	35
IE3-W41R 160 L6C	699	774	63 A	184	172	M40 x 1.5	100/63 AV	223	214	-	M40 x 1.5	4L	35
IE3-W41R 160 M8	611	724	63 A	184	172	M40 x 1.5	100/63 AV	223	214	-	M40 x 1.5	4L	35
IE3-W41R 160 MX8	611	724	63 A	184	172	M40 x 1.5	100/63 AV	223	214	-	M40 x 1.5	4L	35
IE3-W41R 160 L8	699	774	63 A	184	172	M40 x 1.5	100/63 AV	223	214	-	M40 x 1.5	4L	35
IE3-W41R 180 M2C	720	796	63 A	184	172	M40 x 1.5	100/63 AV	223	214	-	M40 x 1.5	4L	35
IE3-W41R 180 M4	720	796	63 A	184	172	M40 x 1.5	100/63 AV	223	214	-	M40 x 1.5	4L	35
IE3-W41R 180 L4	770	846	63 A	184	172	M40 x 1.5	100/63 AV	223	214	-	M40 x 1.5	4L	35
IE3-W41R 180 L6C	720	796	63 A	184	172	M40 x 1.5	100/63 AV	223	214	-	M40 x 1.5	4L	35
IE3-W41R 180 L8	720	796	63 A	184	172	M40 x 1.5	100/63 AV	223	214	-	M40 x 1.5	4L	35
IE3-W41R 200 L2	807	891	100 A	222	214	M50 x 1.5	200 A-SB	335	270	200	M50 x 1.5	4L	40
IE3-W41R 200 LX2C	807	891	100 A	222	214	M50 x 1.5	200 A-SB	335	270	200	M50 x 1.5	4L	40
IE3-W41R 200 L4C	807	891	100 A	222	214	M50 x 1.5	200 A-SB	335	270	200	M50 x 1.5	4L	35
IE3-W41R 200 L6	807	891	100 A	222	214	M50 x 1.5	200 A-SB	335	270	200	M50 x 1.5	4L	35
IE3-W41R 200 LX6C	807	891	100 A	222	214	M50 x 1.5	200 A-SB	335	270	200	M50 x 1.5	4L	35
IE3-W41R 200 L8	770	846	63 A	184	172	M50 x 1.5	100/63 AV	223	214	200	M50 x 1.5	4L	35
IE3-W41R 225 M2	917	947	100 A	222	214	M50 x 1.5	200 A-SB	335	270	200	M50 x 1.5	8L	45
IE3-W41R 225 S4C	892	971	100 A	222	214	M50 x 1.5	200 A-SB	335	270	200	M50 x 1.5	8L	40
IE3-W41R 225 M4	997	1027	100 A	222	214	M50 x 1.5	200 A-SB	335	270	200	M50 x 1.5	8L	45
IE3-W41R 225 M6	997	1027	100 A	222	214	M50 x 1.5	200 A-SB	335	270	200	M50 x 1.5	8L	45
IE3-W41R 225 S8	842	921	100 A	222	214	M50 x 1.5	200 A-SB	335	270	200	M50 x 1.5	8L	40
IE3-W41R 225 M8	947	977	100 A	222	214	M50 x 1.5	200 A-SB	335	270	200	M50 x 1.5	8L	45
IE3-W41R 250 M2	1009	1072	200 A	222	214	M63 x 1.5	200 A-SB	335	270	200	M63 x 1.5	8L	55
IE3-W41R 250 M4	1009	1072	200 A	222	214	M63 x 1.5	200 A-SB	335	270	200	M63 x 1.5	8L	50
IE3-W41R 250 M6	1009	1072	200 A	222	214	M63 x 1.5	200 A-SB	335	270	200	M63 x 1.5	8L	50
IE3-W41R 250 M8	997	1112	200 A	222	214	M63 x 1.5	200 A-SB	335	270	200	M63 x 1.5	8L	50
IE3-W41R 280 S2	1009	1072	200 A	222	214	M63 x 1.5	200 A-SB	335	270	200	M63 x 1.5	8L	55
IE3-W41R 280 M2	1055	1118	200 A	222	214	M63 x 1.5	200 A-SB	335	270	200	M63 x 1.5	8L	55
IE3-W41R 280 S4	1055	1118	200 A	222	214	M63 x 1.5	200 A-SB	335	270	200	M63 x 1.5	8L	50
IE3-W41R 280 M4	1215	1273	200 A	222	214	M63 x 1.5	200 A-SB	335	270	200	M63 x 1.5	8L	55
IE3-W41R 280 S6	1160	1218	200 A	222	214	M63 x 1.5	200 A-SB	335	270	200	M63 x 1.5	8L	55
IE3-W41R 280 M6	1215	1273	200 A	222	214	M63 x 1.5	200 A-SB	335	270	200	M63 x 1.5	8L	55
IE3-W41R 280 S8	1135	1218	200 A	222	214	M63 x 1.5	200 A-SB	335	270	200	M63 x 1.5	8L	55
IE3-W41R 280 M8	1215	1273	200 A	222	214	M63 x 1.5	200 A-SB	335	270	200	M63 x 1.5	8L	55

Three-phase motors with squirrel-cage rotor for operation in Zone 2 according to EN 60079-15 (EN 60079-7)

Type of explosion protection „n“ (Increased safety „ec“) and for operation in Zones 21 and 22 according to EN 60079-31, Type of explosion protection – Protection by enclosure „tb, tc“, Premium Efficiency IE3 (VIK Recommendation 1, Three-Phase Asynchronous Motors – Technical Requirements 03.2011)

with surface cooling, type of cooling IC 411
Size 315

Type of construction IM B5 [IM 3001]

Type of construction IM V1 [IM 3011]

Flange dimensions, see page 10/6

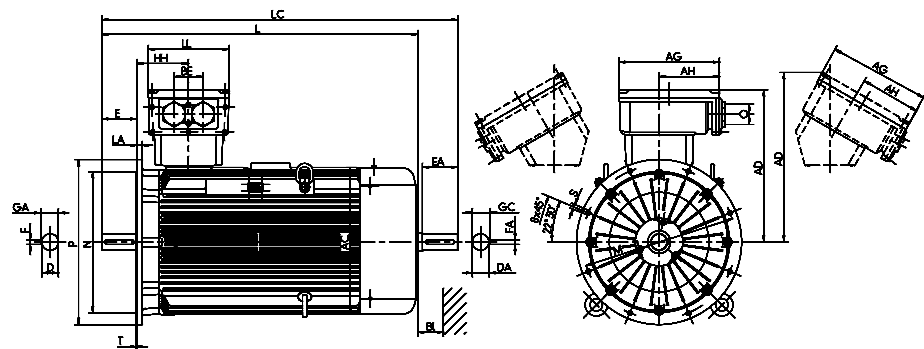

Type designation	Flange size	AC	AD	AD**)	D	DA	DB**)	E	EA	F	FA	GA	GC	H	HH	L
		g	g1	g1 VIK	d	d1		l	l1	u	u1	t	t1	h	A	k
IE3-W41R 315 S2	FF 600	550	460	460	65	65	M20	140	140	18	18	69	69	315	211	1050
IE3-W41R 315 M2	FF 600	550	460	460	65	65	M20	140	140	18	18	69	69	315	211	1105
IE3-W41R 315 MX2	FF 600	610	494	681	65	65	M20	140	140	18	18	69	69	315	211	1200
IE3-W41R 315 MY2	FF 600	610	681	681	65	65	M20	140	140	18	18	69	69	315	230	1270
IE3-W41R 315 L2	FF 600	610	681	681	65	65	M20	140	140	18	18	69	69	315	230	1390
IE3-W41R 315 LX2	FF 600	610	681	681	65	65	M20	140	140	18	18	69	69	315	230	1510
IE3-W41R 315 S4	FF 600	550	460	460	80	70	M20	170	140	22	20	85	74.5	315	211	1080
IE3-W41R 315 M4	FF 600	550	460	460	80	70	M20	170	140	22	20	85	74.5	315	211	1135
IE3-W41R 315 MX4	FF 600	610	494	681	80	70	M20	170	140	22	20	85	74.5	315	230	1230
IE3-W41R 315 MY4	FF 600	610	681	681	80	70	M20	170	140	22	20	85	74.5	315	230	1300
IE3-W41R 315 L4	FF 600	610	681	681	80	70	M20	170	140	22	20	85	74.5	315	230	1420
IE3-W41R 315 LX4	FF 600	610	681	681	80	70	M20	170	140	22	20	85	74.5	315	230	1540
IE3-W41R 315 S6	FF 600	550	460	460	80	70	M20	170	140	22	20	85	74.5	315	211	1135
IE3-W41R 315 M6	FF 600	610	681	681	80	70	M20	170	140	22	20	85	74.5	315	230	1300
IE3-W41R 315 MX6	FF 600	610	681	681	80	70	M20	170	140	22	20	85	74.5	315	230	1300
IE3-W41R 315 L6	FF 600	610	681	681	80	70	M20	170	140	22	20	85	74.5	315	230	1420
IE3-W41R 315 S8	FF 600	550	460	460	80	70	M20	170	140	22	20	85	74.5	315	211	1135
IE3-W41R 315 M8	FF 600	610	681	681	80	70	M20	170	140	22	20	85	74.5	315	230	1300
IE3-W41R 315 MX8	FF 600	610	681	681	80	70	M20	170	140	22	20	85	74.5	315	230	1300
IE3-W41R 315 L8	FF 600	610	681	681	80	70	M20	170	140	22	20	85	74.5	315	230	1420

) Centre holes to DIN 332-DS ...

** Terminal box left/right

Three-phase motors with squirrel-cage rotor for operation in Zone 2 according to EN 60079-15 (EN 60079-7)

Type of explosion protection „n“ (Increased safety „ec“) and for operation in Zones 21 and 22 according to EN 60079-31, Type of explosion protection – Protection by enclosure „tb, tc“, Premium Efficiency IE3 (VIK Recommendation 1, Three-Phase Asynchronous Motors – Technical Requirements 03.2011)

with surface cooling, type of cooling IC 411
Size 315

Type of construction IM B5 [IM 3001]

Type of construction IM V1 [IM 3011]

Flange dimensions, see page 10/6

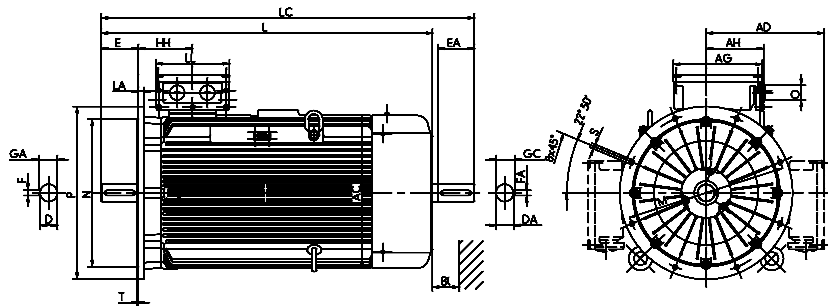

Type designation	L	LC	TB Type Ex e IIC	AG	LL	AH	O	TB Type Ex e IIC	AG	LL	AH	O	BI
	k IM V1	k1	Standard	x	z	-	r	VIK	x	z	-	-	BI
IE3-W41R 315 S2	1160	1218	400 A-SB	415	340	265	M63 x 1.5	400 A-SB	415	340	265	M63 x 1.5	55
IE3-W41R 315 M2	1215	1273	400 A-SB	415	340	265	M63 x 1.5	400 A-SB	415	340	265	M63 x 1.5	55
IE3-W41R 315 MX2	1310	1378	630 A	496	390	301	M63 x 1.5	630 A	496	390	301	M63 x 1.5	55
IE3-W41R 315 MY2	1380	1448	630 A	496	390	301	M63 x 1.5	630 A	496	390	301	M63 x 1.5	55
IE3-W41R 315 L2	1500	1568	630 A	496	390	301	M63 x 1.5	630 A	496	390	301	M63 x 1.5	55
IE3-W41R 315 LX2	1620	1688	630 A	496	390	301	M63 x 1.5	630 A	496	390	301	M63 x 1.5	55
IE3-W41R 315 S4	1190	1248	400 A-SB	415	340	265	M63 x 1.5	400 A-SB	415	340	265	M63 x 1.5	55
IE3-W41R 315 M4	1245	1303	400 A-SB	415	340	265	M63 x 1.5	400 A-SB	415	340	265	M63 x 1.5	55
IE3-W41R 315 MX4	1340	1408	400 A-SB	415	340	265	M63 x 1.5	630 A	496	390	301	M63 x 1.5	55
IE3-W41R 315 MY4	1410	1478	630 A	496	390	301	M63 x 1.5	630 A	496	390	301	M63 x 1.5	55
IE3-W41R 315 L4	1430	1598	630 A	496	390	301	M63 x 1.5	630 A	496	390	301	M63 x 1.5	55
IE3-W41R 315 LX4	1650	1718	630 A	496	390	301	M63 x 1.5	630 A	496	390	301	M63 x 1.5	55
IE3-W41R 315 S6	1245	1303	400 A-SB	415	340	265	M63 x 1.5	400 A-SB	415	340	265	M63 x 1.5	55
IE3-W41R 315 M6	1410	1478	630 A	496	390	301	M63 x 1.5	630 A	496	390	301	M63 x 1.5	55
IE3-W41R 315 MX6	1410	1478	630 A	496	390	301	M63 x 1.5	630 A	496	390	301	M63 x 1.5	55
IE3-W41R 315 L6	1530	1598	630 A	496	390	301	M63 x 1.5	630 A	496	390	301	M63 x 1.5	55
IE3-W41R 315 S8	1245	1303	400 A-SB	415	340	265	M63 x 1.5	400 A-SB	415	340	265	M63 x 1.5	55
IE3-W41R 315 M8	1410	1478	630 A	496	390	301	M63 x 1.5	630 A	496	390	301	M63 x 1.5	55
IE3-W41R 315 MX8	1530	1478	630 A	496	390	301	M63 x 1.5	630 A	496	390	301	M63 x 1.5	55
IE3-W41R 315 L8	1530	1598	630 A	496	390	301	M63 x 1.5	630 A	496	390	301	M63 x 1.5	55

Three-phase motors with squirrel-cage rotor for operation in Zone 2 according to EN 60079-15 (EN 60079-7)

Type of explosion protection „n“ (Increased safety „ec“) and and for operation in Zones 21 and 22 according to EN 60079-31, Type of explosion protection – Protection by enclosure „tb, tc“, Premium Efficiency IE3 (VIK Recommendation 1, Three-Phase Asynchronous Motors – Technical Requirements 03.2011)

with surface cooling, type of cooling IC 411

Size 355

Type of construction IM B5 [IM 3001]

Type of construction IM V1 [IM 3011]

Flange dimensions, see page 10/6

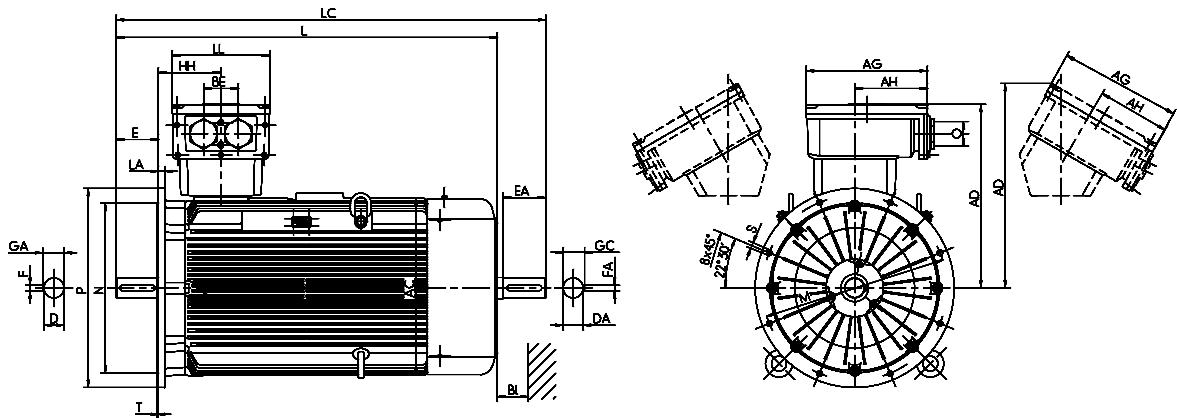

Type designation	Flange size	AC	AD	AD ^{*)}	D	DA	DB ^{*)}	E	EA	F	FA	GA	GC	H	HH	L
		g	g1	g1 VIK	d	d1		l	l1	u	u1	t	t1	h	A	k
IE3-W41R 355 M2G	FF 740	715	736	817	80	-	M20	170	-	22	-	85	-	355	250	1530
IE3-W41R 355 M4	FF 740	715	736	817	100	80	M24	210	170	28	22	106	85	355	250	1570
IE3-W41R 355 M6	FF 740	715	736	817	100	80	M24	210	170	28	22	106	85	355	250	1570
IE3-W41R 355 MX6	FF 740	715	736	817	100	80	M24	210	170	28	22	106	85	355	250	1770
IE3-W41R 355 L6	FF 740	715	729	819	100	80	M24	210	170	28	22	106	85	355	327	1770
IE3-W41R 355 LX6	FF 740	715	729	819	100	80	M24	210	170	28	22	106	85	355	327	1770
IE3-W41R 355 MY8	FF 740	715	736	817	100	80	M24	210	170	28	22	106	85	355	250	1570
IE3-W41R 355 M8	FF 740	715	736	817	100	80	M24	210	170	28	22	106	85	355	250	1570
IE3-W41R 355 MX8	FF 740	715	736	817	100	80	M24	210	170	28	22	106	85	355	250	1770
IE3-W41R 355 LY8	FF 740	715	729	819	100	80	M24	210	170	28	22	106	85	355	327	1770

^{*)} Centre holes to DIN 332-DS ...

^{**)} Terminal box inclined left/right

Type designation	L	LC	TB Type Ex e IIC	AG	LL	AH	BE	O	TB Type Ex e IIC	AG	LL	AH	O	BI
	k IM V1	k1	Standard	x	z	-		r	VIK	x	z	-	-	BI
IE3-W41R 355 M2G	1650	-	TB 630 A	496	390	301	140	M75 x 1.5	TB 630 A	496	390	301	M75 x 1.5	60
IE3-W41R 355 M4	1690	1755	TB 630 A	496	390	301	140	M75 x 1.5	TB 630 A	496	390	301	M75 x 1.5	60
IE3-W41R 355 M6	1690	1755	TB 630 A	496	390	301	140	M75 x 1.5	TB 630 A	496	390	301	M75 x 1.5	60
IE3-W41R 355 MX6	1890	1875	TB 630 A	496	390	301	140	M75 x 1.5	TB 630 A	496	390	301	M75 x 1.5	60
IE3-W41R 355 L6	1890	1875	TB 1000 A	615	474	385	200	M75 x 1.5	TB 1000 A	615	474	385	M75 x 1.5	60
IE3-W41R 355 LX6	1890	1875	TB 1000 A	615	474	385	200	M75 x 1.5	TB 1000 A	615	474	385	M75 x 1.5	60
IE3-W41R 355 MY8	1690	1755	TB 630 A	496	390	301	140	M75 x 1.5	TB 630 A	496	390	301	M75 x 1.5	60
IE3-W41R 355 M8	1690	1755	TB 630 A	496	390	301	140	M75 x 1.5	TB 630 A	496	390	301	M75 x 1.5	60
IE3-W41R 355 MX8	1890	1875	TB 630 A	496	390	301	140	M75 x 1.5	TB 630 A	496	390	301	M75 x 1.5	60
IE3-W41R 355 LY8	1890	1875	TB 1000 A	615	474	385	200	M75 x 1.5	TB 1000 A	615	474	385	M75 x 1.5	60

Three-phase motors with squirrel-cage rotor for operation in Zone 2 according to EN 60079-15 (EN 60079-7)

Type of explosion protection „n“ (Increased safety „ec“) and for operation in Zones 21 and 22 according to EN 60079-31, Type of explosion protection – Protection by enclosure „tb, tc“, High Efficiency IE2 (VIK Recommendation 1, Three-Phase Asynchronous Motors – Technical Requirements 03.2011)

with surface cooling, type of cooling IC 411
Size 80 to 160

Type of construction IM B3 [IM 1001]

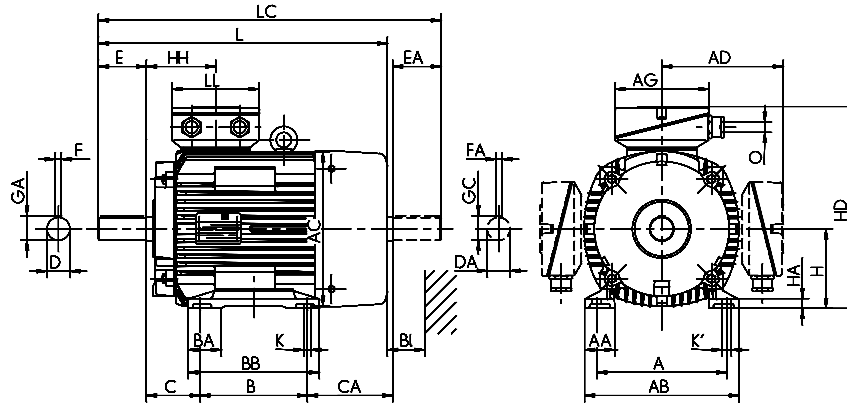

Type designation	Flange size	A	AA	AB	AC	AD	AD	B	BA	BB	C	CA	D	DA	DB ^{*)}	E	EA	F	FA
		b	n	f	g	g1	VIK g1	a	m	e	w1	w2	d	d1		l	l1	u	u1
IE2-W21R 80 K2, 4, 6, 8 Ex nA II T3	A200	125	26	152	157	138		100	-	124	50	80	19	19	M6	40	40	6	6
IE2-WE(2)1R 80 G2, 4, 6, 8 Ex nA II T3	A200	125	26	152	157	138		100	-	146	50	102	19	19	M6	40	40	6	6
IE2-WE(2)1R 90 S2, 4, 6, 8 Ex nA II T3	A200	140	40	178	177	146		100	-	130	56	159	24	24	M8	50	50	8	8
IE2-WE1R 90 L2 Ex nA II T3	A200	140	40	178	177	146		125	-	155	56	134	24	24	M8	50	50	8	8
IE2-WE1R 90 L4, 6, 8 Ex nA II T3	A200	140	40	178	177	146		125	-	155	56	164	24	24	M8	50	50	8	8
IE2-WE(2)1R 100 L2, S8 Ex nA II T3	A250	160	42	193	196	155		140	-	175	63	102	28	28	M10	60	60	8	8
IE2-WE1R 100 L4 Ex nA II T3	A250	160	42	193	196	155		140	-	175	63	136	28	28	M10	60	60	8	8
IE2-W21R 100 LX6 Ex nA II T3	A250	160	42	193	196	155		140	-	175	63	136	28	28	M10	60	60	8	8
IE2-WE1R 100 LX4 Ex nA II T3	A250	160	42	193	196	155		140	-	175	63	166	28	28	M10	60	60	8	8
IE2-WE1R 112 MX2 Ex nA II T3	A250	190	52	225	196	155		140	-	180	70	129	28	28	M10	60	60	8	8
IE2-WE1R 112 MV2 Ex nA II T3	A250	190	52	225	196	155		140	-	180	70	159	28	28	M10	60	60	8	8
IE2-WE1R 112 MV6, 8 Ex nA II T3	A250	190	52	225	196	155		140	-	180	70	159	28	28	M10	60	60	8	8
IE2-WE1R 112 MZ4 Ex nA II T3	A250	190	52	225	196	155		140	-	180	70	199	28	28	M10	60	60	8	8
IE2-WE1R 112 MZ6 Ex nA II T3	A250	190	52	225	196	155		140	-	180	70	199	28	28	M10	60	60	8	8
IE2-WE1R 112 M2 Ex nA IIC T3	A250	190	45	226	217	220	220	140	42	172	70	192	28	28	M10	60	60	8	8
IE2-WE1R 112 M4 Ex nA IIC T3	A250	190	45	226	217	220	220	140	42	172	70	192	28	28	M10	60	60	8	8
IE2-WE1R 112 M6 Ex nA IIC T3	A250	190	45	226	217	220	220	140	42	172	70	192	28	28	M10	60	60	8	8
IE2-WE1R 132 S2T Ex nA II T3	A300	216	50	256	217	220	220	140	53	180	89	173	38	32	M12	80	80	10	10
IE2-WE1R 132 S2 Ex nA IIC T3	A300	216	50	256	217	220	220	140	53	180	89	173	38	32	M12	80	80	10	10
IE2-WE1R 132 SX2 Ex nA IIC T3	A300	216	50	256	258	246	246	140	53	180	89	176	38	32	M12	80	80	10	10
IE2-WE1R 132 S4 Ex nA IIC T3	A300	216	50	256	258	246	246	140	53	180	89	186	38	32	M12	80	80	10	10
IE2-WE1R 132 S6 Ex nA IIC T3	A300	216	50	256	217	220	220	140	53	180	89	173	38	32	M12	80	80	10	10
IE2-WE1R 132 M4 Ex nA IIC T3	A300	216	50	256	258	246	246	178	53	218	89	186	38	38	M12	80	80	10	10
IE2-WE1R 132 M6 Ex nA IIC T3	A300	216	50	256	258	246	246	178	53	218	89	138	38	32	M12	80	80	10	10
IE2-WE1R 132 MX6 Ex nA IIC T3	A300	216	50	256	258	246	246	178	53	218	89	186	38	38	M12	80	80	10	10
IE2-WE2R 132 S4 Ex nA IIC T3	A300	216	50	256	217	220	220	140	53	180	89	223	38	32	M12	80	80	10	10
IE2-WE2R 132 M6 Ex nA IIC T3	A300	216	50	256	217	220	220	178	53	218	89	135	38	32	M12	80	80	10	10
IE2-WE2R 132 M8 Ex nA IIC T3	A300	216	50	256	217	220	220	178	53	218	89	135	38	32	M12	80	80	10	10
IE2-WE1R 160 M2 Ex nA IIC T3	A350	254	55	296	313	249	275	210	60	257	108	148	42	42	M16	110	110	12	12
IE2-WE1R 160 M4 Ex nA IIC T3	A350	254	55	296	313	249	275	210	60	257	108	148	42	42	M16	110	110	12	12
IE2-WE1R 160 M8 Ex nA IIC T3	A350	254	55	296	258	256	210	60	257	108	135	42	38	M16	110	80	12	10	
IE2-WE1R 160 M6 Ex nA IIC T3	A350	254	55	296	313	249	275	210	60	257	108	148	42	42	M16	110	110	12	12
IE2-WE1R 160 MX2 Ex nA IIC T3	A350	254	55	296	313	249	275	210	56	257	108	186	42	42	M16	110	110	12	12
IE2-WE1R 160 L2 Ex nA IIC T3	A350	254	55	296	313	249	275	254	60	301	108	142	42	42	M16	110	110	12	12
IE2-WE1R 160 L4 Ex nA IIC T3	A350	254	55	296	313	249	275	254	60	301	108	200	42	42	M16	110	110	12	12
IE2-WE1R 160 L6 Ex nA IIC T3	A350	254	55	296	313	249	275	254	60	301	108	142	42	42	M16	110	110	12	12
IE2-WE2R 160 M4 Ex nA IIC T3	A350	254	55	296	258	256	210	60	257	108	185	42	38	M16	110	80	12	10	
IE2-WE2R 160 L4 Ex nA IIC T3	A350	254	55	296	313	249	275	254	60	301	108	192	42	42	M16	110	110	12	12
IE2-WE2R 160 M6 Ex nA IIC T3	A350	254	55	296	258	256	210	60	257	108	185	42	38	M16	110	80	12	10	
IE2-WE2R 160 L6 Ex nA IIC T3	A350	254	55	296	313	249	275	254	60	301	108	192	42	42	M16	110	110	12	12
IE2-WE2R 160 MX8 Ex nA IIC T3	A350	254	55	296	258	256	210	60	257	108	185	42	38	M16	110	80	12	10	

Low voltage electrical machines

Three-phase motors with squirrel-cage rotor for operation in Zone 2 according to EN 60079-15 (EN 60079-7)

Type of explosion protection „n“ (Increased safety „ec“) and for operation in Zones 21 and 22 according to EN 60079-31, Type of explosion protection – Protection by enclosure „tb, tc“, High Efficiency IE2 (VIK Recommendation 1, Three-Phase Asynchronous Motors – Technical Requirements 03.2011)

with surface cooling, type of cooling IC 411
Baufsize 80 to 160

Type of construction IM B35 [IM 2001]

Flange dimensions, see page 10/6

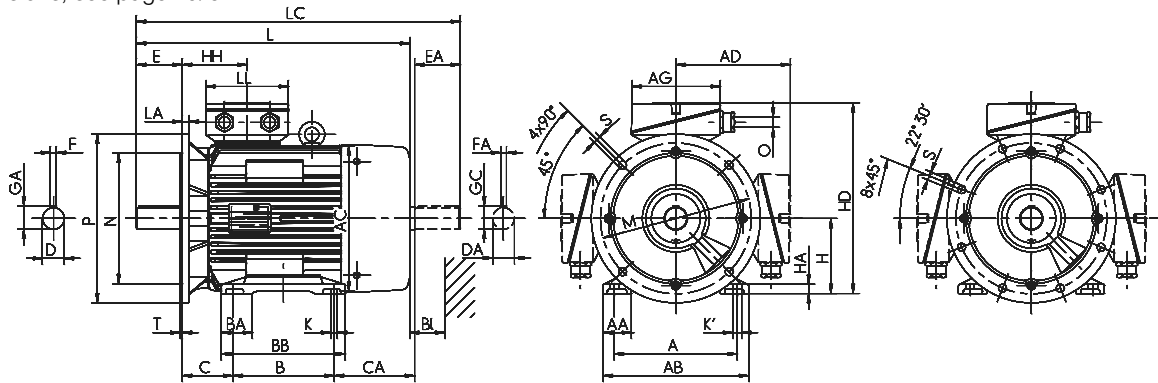

Type designation	GA	GC	H	HA	HD	HD ^{*)}	HD	HH	K	K'	L	L	L	LC	LC	TB Type	AG	LL	TB Type	AG	LL	AH	O	LB	BI
	t	t1	h	c	p	p	VIK p	A	s	s'	k	k	k	k1	k1	Ex e IIC Standard	x	z	Ex e IIC VIK	x	z	-	-	Bl	Bl
IE2-W21R 80 K2, 4, 6, 8 Ex nA II T3	21.5	21.5	80	9	218	***)	79	10	10	267	296	267	310	310	VIK16_M20			VIK16_M20						16	4L
IE2-WE(2)1R 80 G2, 4, 6, 8 Ex nA II T3	21.5	21.5	80	9	218	***)	79	10	10	289	318	289	332	332	VIK16_M20			VIK16_M20						16	4L
IE2-WE(2)1R 90 S2, 4, 6, 8 Ex nA II T3	27	27	90	10.5	236	***)	84	10	10	323	390	361	376	415	VIK16_M25			VIK16_M25						18	4L
IE2-WE1R 90 L2 Ex nA II T3	27	27	90	10.5	236	***)	84	10	10	323	390	361	376	415	VIK16_M25			VIK16_M25						18	4L
IE2-WE1R 90 L4, 6, 8 Ex nA II T3	27	27	90	10.5	236	***)	84	10	10	353	420	391	406	445	VIK16_M25			VIK16_M25						18	4L
IE2-WE(2)1R 100 L2, S8 Ex nA II T3	31	31	100	13	255	***)	86	12	12	359	388	359	425	425	VIK16_M25			VIK16_M25						20	4L
IE2-WE1R 100 L4 Ex nA II T3	31	31	100	13	255	***)	86	12	12	393	422	393	459	459	VIK16_M25			VIK16_M25						20	4L
IE2-W21R 100 LX6 Ex nA II T3	31	31	100	13	255	***)	86	12	12	393	422	393	459	459	VIK16_M25			VIK16_M25						20	4L
IE2-WE1R 100 LX4 Ex nA II T3	31	31	100	13	255	***)	86	12	12	423	452	423	489	489	VIK16_M25			VIK16_M25						20	4L
IE2-WE1R 112 MX2 Ex nA II T3	31	31	112	18	267	***)	86	12	12	393	422	393	459	459	VIK16_M25			VIK16_M25						20	4L
IE2-WE1R 112 MV2 Ex nA II T3	31	31	112	18	267	***)	86	12	12	423	452	423	489	489	VIK16_M25			VIK16_M25						20	4L
IE2-WE1R 112 MV6, 8 Ex nA II T3	31	31	112	18	267	***)	86	12	12	423	452	423	489	489	VIK16_M25			VIK16_M25						20	4L
IE2-WE1R 112 M24 Ex nA II T3	31	31	112	18	267	***)	86	12	12	463	492	463	529	529	VIK16_M25			VIK16_M25						20	4L
IE2-WE1R 112 M26 Ex nA II T3	31	31	112	18	267	***)	86	12	12	463	492	463	529	529	VIK16_M25			VIK16_M25						20	4L
IE2-WE1R 112 M2 Ex nA IIC T3	41	31	132	18	287	***)	105	12	12	462	491	462	528	528	VIK16_M32			VIK16_M32						20	4L
IE2-WE1R 112 M4 Ex nA IIC T3	31	31	112	15	333	237	333	108	12	12	459	499	459	522	522	25 A	143	134	25 AV	143	134	-	M32 x 1.5	35	4L
IE2-WE1R 112 M6 Ex nA IIC T3	31	31	112	15	333	237	333	108	12	12	459	499	459	522	522	25 A	143	134	25 AV	143	134	-	M32 x 1.5	35	4L
IE2-WE1R 132 S2T Ex nA IIC T3	31	31	112	15	333	237	333	108	12	12	459	499	459	522	522	25 A	143	134	25 AV	143	134	-	M32 x 1.5	35	4L
IE2-WE1R 132 S2 Ex nA IIC T3	41	35	132	16	353	257	353	108	12	12	479	519	479	562	562	25 A	143	134	25 AV	143	134	-	M32 x 1.5	35	4L
IE2-WE1R 132 SX2 Ex nA IIC T3	41	41	132	15	374	279	374	114	12	12	481	521	481	565	565	25 A	143	134	25 AV	143	134	-	M32 x 1.5	35	4L
IE2-WE1R 132 S4 Ex nA IIC T3	41	41	132	15	374	279	374	114	12	12	529	569	529	613	613	25 A	143	134	25 AV	143	134	-	M32 x 1.5	35	4L
IE2-WE1R 132 S6 Ex nA IIC T3	41	35	132	16	353	257	353	108	12	12	479	519	479	562	562	25 A	143	134	25 AV	143	134	-	M32 x 1.5	35	4L
IE2-WE1R 132 M4 Ex nA IIC T3	41	41	132	15	374	279	374	114	12	12	529	569	529	613	613	25 A	143	134	25 AV	143	134	-	M32 x 1.5	35	4L
IE2-WE1R 132 M6 Ex nA IIC T3	41	41	132	16	374	279	374	114	12	12	481	521	481	565	565	25 A	143	134	25 AV	143	134	-	M32 x 1.5	35	4L
IE2-WE1R 132 MX6 Ex nA IIC T3	41	41	132	15	374	279	374	114	12	12	529	569	529	613	613	25 A	143	134	25 AV	143	134	-	M32 x 1.5	35	4L
IE2-WE2R 132 S4 Ex nA IIC T3	41	35	132	16	353	257	353	108	12	12	529	569	529	612	612	25 A	143	134	25 AV	143	134	-	M32 x 1.5	35	4L
IE2-WE2R 132 M6 Ex nA IIC T3	41	35	132	16	353	257	353	108	12	12	529	569	529	612	612	25 A	143	134	25 AV	143	134	-	M32 x 1.5	35	4L
IE2-WE2R 132 M8 Ex nA IIC T3	41	35	132	16	353	257	353	108	12	12	529	569	529	612	612	25 A	143	134	25 AV	143	134	-	M32 x 1.5	35	4L
IE2-WE1R 160 M2 Ex nA IIC T3	45	45	160	18	409	336	435	138	15	20	571	611	571	686	686	63 A	184	172	100/63 AV	223	214	-	M40 x 1.5	35	4L
IE2-WE1R 160 M4 Ex nA IIC T3	45	45	160	18	409	336	435	138	15	20	571	611	571	686	686	63 A	184	172	100/63 AV	223	214	-	M40 x 1.5	35	4L
IE2-WE1R 160 M8 Ex nA IIC T3	45	41	160	18	417	307	417	114	15	15	559	599	559	643	643	25 A	143	134	25 AV	143	134	-	M32 x 1.5	35	4L
IE2-WE1R 160 M6 Ex nA IIC T3	45	45	160	18	409	336	435	138	15	20	571	611	571	686	686	63 A	184	172	100/63 AV	223	214	-	M40 x 1.5	35	4L
IE2-WE1R 160 MX2 Ex nA IIC T3	45	45	160	18	409	336	435	138	15	20	609	649	609	724	724	63 A	184	172	100/63 AV	223	214	-	M40 x 1.5	35	4L
IE2-WE1R 160 L2 Ex nA IIC T3	45	45	160	18	409	336	435	138	15	20	609	649	609	724	724	63 A	184	172	100/63 AV	223	214	-	M40 x 1.5	35	4L
IE2-WE1R 160 L4 Ex nA IIC T3	45	45	160	18	409	336	435	138	15	20	667	-	667	783	783	63 A	184	172	100/63 AV	223	214	-	M40 x 1.5	35	4L
IE2-WE1R 160 L6 Ex nA IIC T3	45	45	160	18	409	336	435	138	15	20	609	649	609	724	724	63 A	184	172	100/63 AV	223	214	-	M40 x 1.5	35	4L
IE2-WE2R 160 M4 Ex nA IIC T3	45	41	160	18	417	307	417	114	15	15	609	649	609	693	693	25 A	143	134	25 AV	143	134	-	M32 x 1.5	35	4L
IE2-WE2R 160 L4 Ex nA IIC T3	45	45	160	18	409	336	435	138	15	20	659	699	659	774	774	63 A	184	172	100/63 AV	223	214	-	M40 x 1.5	35	4L
IE2-WE2R 160 M6 Ex nA IIC T3	45	41	160	18	417	307	417	114	15	15	609	649	609	693	693	25 A	143	134	25 AV	143	134	-	M32 x 1.5	35	4L
IE2-WE2R 160 L6 Ex nA IIC T3	45	45	160	18	409	336	435	138	15	20	659	699	659	774	774	63 A	184	172	100/63 AV	223	214	-	M40 x 1.5	35	4L
IE2-WE2R 160 MX8 Ex nA IIC T3	45	41	160	18	417	307	417	114	15	15	609	649	609	693	693	25 A	143	134	25 AV	143	134	-	M32 x 1.5	35	4L

*) Terminal box inclined left/right

***) upon request

Three-phase motors with squirrel-cage rotor for operation in Zone 2 according to EN 60079-15 (EN 60079-7)

Type of explosion protection „n“ (Increased safety „ec“) and and for operation in Zones 21 and 22 according to EN 60079-31, Type of explosion protection – Protection by enclosure „tb, tc“, High Efficiency IE2 (VIK Recommendation 1, Three-Phase Asynchronous Motors – Technical Requirements 03.2011)

with surface cooling, type of cooling IC 411
Size 180 to 280

Type of construction IM B3 [IM 1001]

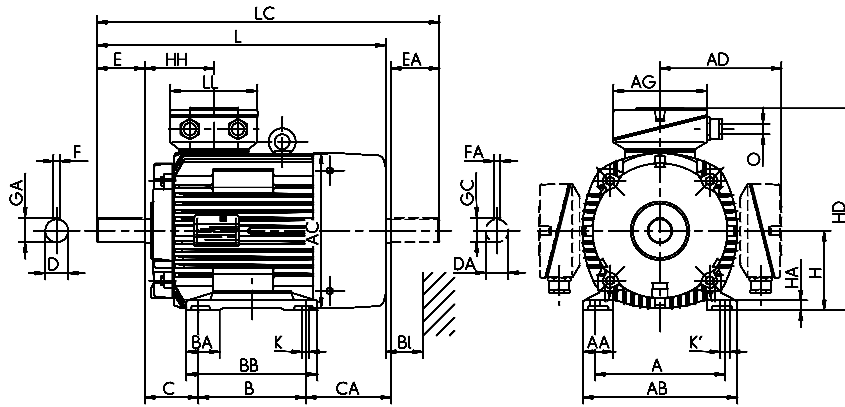

Type designation	Flange size	A	AA	AB	AC	AD	AD	B	BA	BB	C	CA	D	DA	DB ¹⁾	E	EA	F	FA
		b	n	f	g	g1	VIK g1	a	m	e	w1	w2	d	d1		l	l1	u	u1
IE2-WE1R 180 M2 Ex nA IIC T3	A350	279	62	328	351	268	294	241	65	288	121	169	48	48	M16	110	110	14	14
IE2-WE1R 180 M4 Ex nA IIC T3	A350	279	62	328	351	268	294	241	65	288	121	214	48	48	M16	110	110	14	14
IE2-WE1R 180 L4 Ex nA IIC T3	A350	279	62	328	351	268	294	279	65	326	121	176	48	48	M16	110	110	14	14
IE2-WE1R 180 L6 Ex nA IIC T3	A350	279	62	328	351	268	294	279	65	326	121	176	48	48	M16	110	110	14	14
IE2-WE2R 180 M4 Ex nA IIC T3	A350	279	62	328	351	268	294	241	65	288	121	194	48	48	M16	110	110	14	14
IE2-WE2R 180 L6 Ex nA IIC T3	A350	279	62	328	313	249	275	279	65	326	121	154	48	42	M16	110	110	14	12
IE2-WE2R 180 L8 Ex nA IIC T3	A350	279	62	328	313	256	256	279	65	326	121	154	48	42	M16	110	110	14	12
IE2-WE1R 200 L2 Ex nA IIC T3	A400	318	70	372	351	268	294	305	70	360	133	138	55	48	M20	110	110	16	14
IE2-WE1R 200 LX2 Ex nA IIC T3	A400	318	70	372	351	268	294	305	70	360	133	188	55	48	M20	110	110	16	14
IE2-WE1R 200 L4 Ex nA IIC T3	A400	318	70	372	390	311	375	305	70	360	133	193	55	55	M20	110	110	16	16
IE2-WE1R 200 LX6 Ex nA IIC T3	A400	318	70	372	390	311	375	305	70	360	133	193	55	55	M20	110	110	16	16
IE2-WE1R 200 L6 Ex nA IIC T3	A400	318	70	372	351	268	294	305	70	360	133	138	55	48	M20	110	110	16	14
IE2-WE2R 200 LX2 Ex nA IIC T3	A400	318	70	372	351	268	294	305	70	360	133	188	55	48	M20	110	110	16	14
IE2-WE2R 200 LX6 Ex nA IIC T3	A400	318	70	372	351	268	294	305	70	360	133	188	55	48	M20	110	110	16	14
IE2-WE1R 225 M2 Ex nA IIC T3	A450	356	75	413	390	311	375	311	75	368	149	211	55	55	M20	110	110	16	16
IE2-WE1R 225 S4 Ex nA IIC T3	A450	356	75	413	390	311	375	286	75	343	149	236	60	55	M20	140	110	18	16
IE2-WE1R 225 M4 Ex nA IIC T3	A450	356	75	413	440	324	406	311	75	368	149	267	60	55	M20	140	110	18	16
IE2-WE1R 225 S8 Ex nA IIC T3	A450	356	75	413	390	311	375	286	75	343	149	196	60	55	M20	140	110	18	16
IE2-WE1R 225 M6 Ex nA IIC T3	A450	356	75	413	440	324	406	311	75	368	149	267	60	55	M20	140	110	18	16
IE2-WE1R 225 M8 Ex nA IIC T3	A450	356	75	413	440	324	406	311	75	368	149	267	60	55	M20	140	110	18	16
IE2-WE2R 225 M4 Ex nA IIC T3	A450	356	75	413	390	311	375	311	75	368	149	261	60	55	M20	140	110	18	16
IE2-WE2R 225 M6 Ex nA IIC T3	A450	356	75	413	390	311	375	311	75	368	149	221	60	55	M20	140	110	18	16
IE2-WE2R 225 S8 Ex nA IIC T3	A450	356	75	413	390	311	375	286	75	343	149	236	60	55	M20	140	110	18	16
IE2-WE2R 225 M8 Ex nA IIC T3	A450	356	75	413	390	311	375	311	75	368	149	221	60	55	M20	140	110	18	16
IE2-WE1R 250 M2 Ex nA IIC T3	A550	406	84	471	440	362	406	349	84	412	168	210	60	55	M20	140	110	18	16
IE2-WE1R 250 M4 Ex nA IIC T3	A550	406	84	469	490	386	403	349	84	412	168	275	65	55	M20	140	110	18	16
IE2-WE1R 250 M6 Ex nA IIC T3	A550	406	84	469	490	386	403	349	84	412	168	275	65	55	M20	140	110	18	16
IE2-WE2R 250 M4 Ex nA IIC T3	A550	406	84	471	440	362	406	349	84	412	168	260	60	55	M20	140	110	18	16
IE2-WE2R 250 M6 Ex nA IIC T3	A550	406	84	471	440	362	406	349	84	412	168	260	60	55	M20	140	110	18	16
IE2-WE2R 250 M8 Ex nA IIC T3	A550	406	84	471	440	362	406	349	84	412	168	260	60	55	M20	140	110	18	16
IE2-WE1R 280 S2 Ex nA IIC T3	A550	457	94	522	490	386	403	368	96	431	190	234	65	65	M20	140	140	18	18
IE2-WE1R 280 M2 Ex nA IIC T3	A550	457	94	522	490	386	403	419	96	482	190	229	65	65	M20	140	140	18	18
IE2-WE1R 280 S4 Ex nA IIC T3	A550	457	94	522	490	386	403	368	96	431	190	234	75	65	M20	140	140	20	18
IE2-WE1R 280 M4 Ex nA IIC T3	A550	457	94	522	490	386	403	419	96	482	190	229	75	65	M20	140	140	20	18
IE2-WE1R 280 S6 Ex nA IIC T3	A550	457	94	522	490	386	403	368	96	431	190	229	75	65	M20	140	140	20	18
IE2-WE1R 280 M6 Ex nA IIC T3	A550	457	88	522	550	416	433	419	94	482	190	384	75	65	M20	140	140	20	18
IE2-WE1R 280 S8 Ex nA IIC T3	A550	457	94	522	490	386	403	368	96	431	190	229	75	65	M20	140	140	20	18
IE2-WE1R 280 M8 Ex nA IIC T3	A550	457	88	522	550	416	433	419	94	482	190	384	75	65	M20	140	140	20	18

¹⁾ Centre holes to DIN 332-DS ...

Three-phase motors with squirrel-cage rotor for operation in Zone 2 according to EN 60079-15 (EN 60079-7)

Type of explosion protection „n“ (Increased safety „ec“) and and for operation in Zones 21 and 22 according to EN 60079-31, Type of explosion protection – Protection by enclosure „tb, tc“, High Efficiency IE2 (VIK Recommendation 1, Three-Phase Asynchronous Motors – Technical Requirements 03.2011))

with surface cooling, type of cooling IC 411
Size 180 to 280

Type of construction IM B35 [IM 2001]

Flange dimensions, see page 10/6

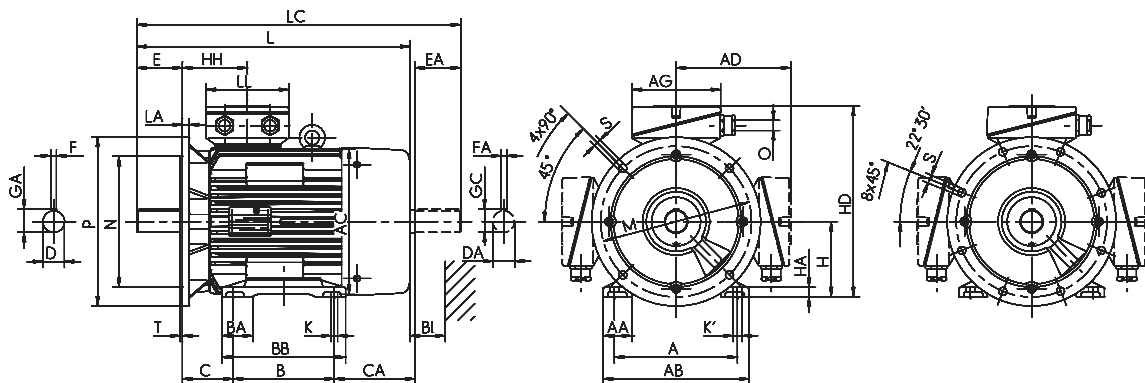

Type designation	GA	GC	H	HA	HD	HD ^{**)}	HD	HH	K	K'	L	L	L	LC	LC	TB Type	AG	LL	TB Type	AG	LL	AH	O	LB	BI
	t	t1	h	c	p	p	VIK	p	A	s	s'	k	k	k1		Ex e IIC	x	z	Ex e IIC	x	z	-	-		Bl
												(IM	(IM	(IM		Standard			VIK						
IE2-WE1R 180 M2 Ex nA IIC T3	51.5	51.5	180	20	447	369	473	147	15	20	635	675	635	751	751	63 A	184	172	100/63 AV	223	214	-	M40 x 1.5	35	4L
IE2-WE1R 180 M4 Ex nA IIC T3	51.5	51.5	180	20	447	369	473	147	15	20	680	720	680	796	796	63 A	184	172	100/63 AV	223	214	-	M40 x 1.5	35	4L
IE2-WE1R 180 L4 Ex nA IIC T3	51.5	51.5	180	20	447	369	473	147	15	20	680	720	680	796	796	63 A	184	172	100/63 AV	223	214	-	M40 x 1.5	35	4L
IE2-WE1R 180 L6 Ex nA IIC T3	51.5	51.5	180	20	447	369	473	147	15	20	680	720	680	796	796	63 A	184	172	100/63 AV	223	214	-	M40 x 1.5	35	4L
IE2-WE2R 180 M4 Ex nA IIC T3	51.5	51.5	180	20	447	369	473	147	15	20	635	675	635	751	751	63 A	184	172	100/63 AV	223	214	-	M40 x 1.5	35	4L
IE2-WE2R 180 L6 Ex nA IIC T3	51.5	45	180	20	429	356	455	138	15	20	659	699	659	774	774	63 A	184	172	100/63 AV	223	214	-	M40 x 1.5	35	4L
IE2-WE2R 180 L8 Ex nA IIC T3	51.5	45	180	20	429	356	455	138	15	20	659	699	659	774	774	63 A	184	172	100/63 AV	223	214	-	M40 x 1.5	35	4L
IE2-WE1R 200 L2 Ex nA IIC T3	59	51.5	200	22	494	389	520	147	19	25	680	720	680	796	796	63 A	184	172	100/63 AV	223	214	-	M50 x 1.5	35	4L
IE2-WE1R 200 LX2 Ex nA IIC T3	59	51.5	200	22	494	389	520	147	19	25	730	-	730	846	846	63 A	184	172	100/63 AV	223	214	-	M50 x 1.5	35	4L
IE2-WE1R 200 L4 Ex nA IIC T3	59	59	200	22	511	417	578	168	19	25	727	767	727	851	851	100 A	222	214	200 A-SB	335	270	200	M50 x 1.5	35	4L
IE2-WE1R 200 LX6 Ex nA IIC T3	59	59	200	22	511	417	578	168	19	25	727	767	727	851	851	100 A	222	214	200 A-SB	335	270	200	M50 x 1.5	35	4L
IE2-WE1R 200 L6 Ex nA IIC T3	59	51.5	200	22	494	389	520	147	19	25	680	720	680	796	796	63 A	184	172	100/63 AV	223	214	-	M40 x 1.5	35	4L
IE2-WE2R 200 LX2 Ex nA IIC T3	59	51.5	200	22	494	389	520	147	19	25	730	770	730	846	846	63 A	184	172	100/63 AV	223	214	-	M40 x 1.5	35	4L
IE2-WE2R 200 LX6 Ex nA IIC T3	59	51.5	200	22	494	389	520	147	19	25	730	770	730	846	846	63 A	184	172	100/63 AV	223	214	-	M50 x 1.5	35	4L
IE2-WE1R 225 M2 Ex nA IIC T3	59	59	225	25	538	442	605	168	19	25	767	807	767	891	891	100 A	222	214	200 A-SB	335	270	200	M50 x 1.5	40	8L
IE2-WE1R 225 S4 Ex nA IIC T3	64	59	225	25	538	442	605	168	19	25	797	837	797	921	921	100 A	222	214	200 A-SB	335	270	200	M50 x 1.5	40	8L
IE2-WE1R 225 M4 Ex nA IIC T3	64	59	225	25	551	***	631	177	19	25	862	947	862	977	977	100 A	222	214	200 A-SB	335	270	200	M50 x 1.5	45	8L
IE2-WE1R 225 S8 Ex nA IIC T3	64	59	225	25	538	442	605	168	19	25	757	797	757	881	881	100 A	222	214	200 A-SB	335	270	200	M63 x 1.5	40	8L
IE2-WE1R 225 M6 Ex nA IIC T3	64	59	225	25	549	***	631	177	19	25	862	947	862	977	977	100 A	222	214	200 A-SB	335	270	200	M50 x 1.5	45	8L
IE2-WE1R 225 M8 Ex nA IIC T3	64	59	225	25	549	***	631	177	19	25	862	947	862	977	977	100 A	222	214	200 A-SB	335	270	200	M50 x 1.5	45	8L
IE2-WE2R 225 M4 Ex nA IIC T3	64	59	225	25	538	442	605	168	19	25	847	887	847	971	971	100 A	222	214	200 A-SB	335	270	200	M50 x 1.5	40	8L
IE2-WE2R 225 M6 Ex nA IIC T3	64	59	225	25	538	442	605	168	19	25	797	837	797	921	921	100 A	222	214	200 A-SB	335	270	200	M50 x 1.5	40	8L
IE2-WE2R 225 S8 Ex nA IIC T3	64	59	225	25	538	442	605	168	19	25	797	837	797	921	921	100 A	222	214	200 A-SB	335	270	200	M50 x 1.5	40	8L
IE2-WE2R 225 M8 Ex nA IIC T3	64	59	225	25	538	442	605	168	19	25	797	837	797	921	921	100 A	222	214	200 A-SB	335	270	200	M50 x 1.5	40	8L
IE2-WE1R 250 M2 Ex nA IIC T3	64	59	250	28	612	***	656	177	24	30	862	947	862	977	977	100 A	222	214	200 A-SB	335	270	200	M63 x 1.5	45	8L
IE2-WE1R 250 M4 Ex nA IIC T3	69	59	250	28	636	***	653	206	24	30	924	1009	924	1042	1042	200 A	290	252	200 A-SB	335	270	200	M63 x 1.5	50	8L
IE2-WE1R 250 M6 Ex nA IIC T3	69	59	250	28	636	***	653	206	24	30	924	1009	924	1042	1042	200 A	290	252	200 A-SB	335	270	200	M63 x 1.5	50	8L
IE2-WE2R 250 M4 Ex nA IIC T3	64	59	250	28	612	***	656	177	24	30	912	997	912	1112	1112	100 A	222	214	200 A-SB	335	270	200	M50 x 1.5	45	8L
IE2-WE2R 250 M6 Ex nA IIC T3	64	59	250	28	612	***	656	177	24	30	912	997	912	1112	1112	100 A	222	214	200 A-SB	335	270	200	M63 x 1.5	45	8L
IE2-WE2R 250 M8 Ex nA IIC T3	64	59	250	28	612	***	656	177	24	30	912	997	912	1112	1112	100 A	222	214	200 A-SB	335	270	200	M63 x 1.5	45	8L
IE2-WE1R 280 S2 Ex nA IIC T3	69	69	280	32	666	***	683	206	24	30	924	1009	924	1072	1072	200 A	290	252	200 A-SB	335	270	200	M63 x 1.5	50	8L
IE2-WE1R 280 M2 Ex nA IIC T3	69	69	280	32	666	***	683	206	24	30	970	1055	970	1118	1118	200 A	290	252	200 A-SB	335	270	200	M63 x 1.5	50	8L
IE2-WE1R 280 S4 Ex nA IIC T3	79.5	69	280	32	666	***	683	206	24	30	924	1009	924	1072	1072	200 A	290	252	200 A-SB	335	270	200	M63 x 1.5	50	8L
IE2-WE1R 280 M4 Ex nA IIC T3	79.5	69	280	32	666	***	683	206	24	30	970	1055	970	1118	1118	200 A	290	252	200 A-SB	335	270	200	M63 x 1.5	50	8L
IE2-WE1R 280 S6 Ex nA IIC T3	79.5	69	280	32	666	***	683	206	24	30	970	1055	970	1118	1118	200 A	290	252	200 A-SB	335	270	200	M63 x 1.5	50	8L
IE2-WE1R 280 M6 Ex nA IIC T3	79.5	69	280	40	696	***	713	211	24	30	1105	1215	1105	1243	1243	200 A	290	252	200 A-SB	335	270	200	M63 x 1.5	55	8L
IE2-WE1R 280 S8 Ex nA IIC T3	79.5	69	280	32	666	***	683	206	24	30	970	1055	970	1118	1118	200 A	290	252	200 A-SB	335	270	200	M63 x 1.5	50	8L
IE2-WE1R 280 M8 Ex nA IIC T3	79.5	69	280	40	696	***	713	211	24	30	1105	1215	1105	1243	1243	200 A	290	252	200 A-SB	335	270	200	M63 x 1.5	55	8L

** Terminal box inclined left/right
*** upon request

Three-phase motors with squirrel-cage rotor for operation in Zone 2 according to EN 60079-15 (EN 60079-7)

Type of explosion protection „n“ (Increased safety „ec“) and and for operation in Zones 21 and 22 according to EN 60079-31, Type of explosion protection – Protection by enclosure „tb, tc“, High Efficiency IE2 (VIK Recommendation 1, Three-Phase Asynchronous Motors – Technical Requirements 03.2011)

with surface cooling, type of cooling IC 411
Size 315 to 355

Type of construction IM B3 [IM 1001]

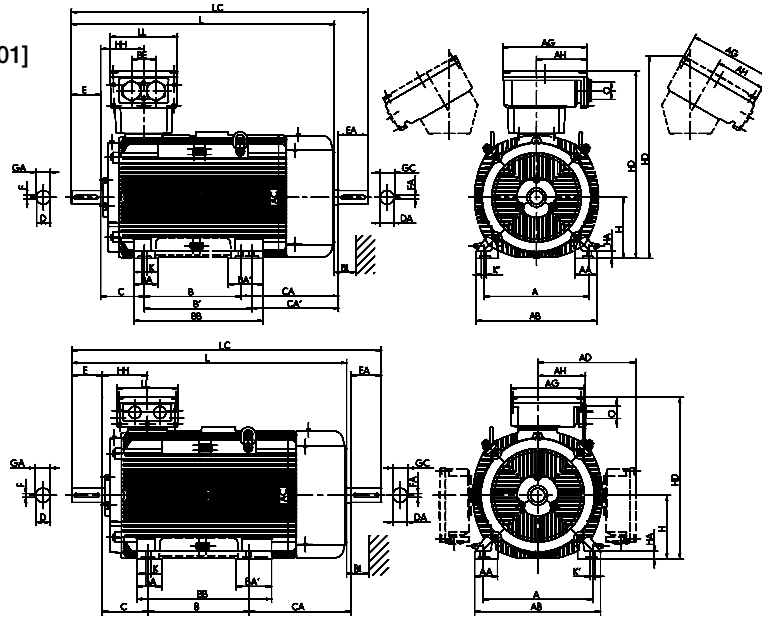

Type designation	Flange size	A	AA	AB	AC	AD	AD	B	BA	BA'	BB	C	CA	D	DA	DB ¹⁾	E	EA	F	FA
		b	n	f	g	g1	VIK g1	a	m	m1	e	w1	w2	d	d1	l	l1	u	u1	
IE2-WE1R 315 S2 Ex nA IIC T3	A660	508	126	590	550	416	460.5	406	120	-	503	216	316	65	65	M20	140	140	18	18
IE2-WE1R 315 M2 Ex nA IIC T3	A660	508	126	590	550	416	460.5	457	120	150	554	216	320	65	65	M20	140	140	18	18
IE2-WE1R 315 MX2 Ex nA IIC T3	A660	508	126	590	550	416	460.5	457	120	150	554	216	400	65	65	M20	140	140	18	18
IE2-WE1R 315 MY2 Ex nA IIC T3	A660	508	110	590	610	494	680.5	457	120	-	573	216	495	65	65	M20	140	140	18	18
IE2-WE1R 315 L2 Ex nA IIC T3	A660	508	110	590	610	494	680.5	508	120	-	624	216	564	65	65	M20	140	140	18	18
IE2-WE1R 315 LX2 Ex nA IIC T3	A660	508	110	590	610	494	680.5	508	120	-	624	216	684	65	65	M20	140	140	18	18
IE2-WE1R 315 S4 Ex nA IIC T3	A660	508	126	590	550	416	460.5	406	120	-	503	216	316	80	70	M20	170	140	22	20
IE2-WE1R 315 M4 Ex nA IIC T3	A660	508	126	590	550	416	460.5	457	120	150	554	216	320	80	70	M20	170	140	22	20
IE2-WE1R 315 MX4 Ex nA IIC T3	A660	508	126	590	550	416	460.5	457	120	150	554	216	400	80	70	M20	170	140	22	20
IE2-WE1R 315 MY4 Ex nA IIC T3	A660	508	110	590	610	494	680.5	457	120	-	573	216	495	80	70	M20	170	140	22	20
IE2-WE1R 315 L4 Ex nA IIC T3	A660	508	110	590	610	494	680.5	508	120	-	624	216	564	80	70	M20	170	140	22	20
IE2-WE1R 315 LX4 Ex nA IIC T3	A660	508	110	590	610	494	680.5	508	120	-	624	216	684	80	70	M20	170	140	22	20
IE2-WE1R 315 S6 Ex nA IIC T3	A660	508	126	590	550	416	460.5	406	120	150	554	216	320	80	70	M20	170	140	22	20
IE2-WE1R 315 M6 Ex nA IIC T3	A660	508	126	590	550	416	460.5	457	120	150	554	216	320	80	70	M20	170	140	22	20
IE2-WE1R 315 MX6 Ex nA IIC T3	A660	508	110	590	610	494	680.5	457	120	-	573	216	495	80	70	M20	170	140	22	20
IE2-WE1R 315 MY6 Ex nA IIC T3	A660	508	110	590	610	494	680.5	457	120	-	573	216	495	80	70	M20	170	140	22	20
IE2-WE1R 315 L6 Ex nA IIC T3	A660	508	110	590	610	494	680.5	508	120	-	624	216	564	80	70	M20	170	140	22	20
IE2-WE1R 315 LX6 Ex nA IIC T3	A660	508	110	590	610	494	680.5	508	120	-	624	216	684	80	70	M20	170	140	22	20
IE2-WE1R 315 S8 Ex nA IIC T3	A660	508	126	590	550	416	460.5	406	120	150	554	216	320	80	70	M20	170	140	22	20
IE2-WE1R 315 M8 Ex nA IIC T3	A660	508	126	590	550	416	460.5	457	120	150	554	216	320	80	70	M20	170	140	22	20
IE2-WE1R 315 MX8 Ex nA IIC T3	A660	508	110	590	610	494	680.5	457	120	-	573	216	495	80	70	M20	170	140	22	20
IE2-WE1R 315 MY8 Ex nA IIC T3	A660	508	110	590	610	494	680.5	457	120	-	573	216	495	80	70	M20	170	140	22	20
IE2-WE1R 315 L8 Ex nA IIC T3	A660	508	110	590	610	494	680.5	508	120	-	624	216	564	80	70	M20	170	140	22	20
IE2-WE1R 315 LX8 Ex nA IIC T3	A660	508	110	590	610	494	680.5	508	120	-	624	216	684	80	70	M20	170	140	22	20
IE2-WE2R 355 MY2G Ex nA IIC T3	A800	610	130	700	715	736	736	560	140	200	750	254	-	80	80	M20	170	-	22	-
IE2-WE2R 355 M2G Ex nA IIC T3	A800	610	130	700	715	736	736	560	140	200	750	254	-	80	80	M20	170	-	22	-
IE2-WE2R 355 MY4 Ex nA IIC T3	A800	610	130	700	715	736	736	560	140	200	750	254	561	100	80	M24	210	170	28	22
IE2-WE2R 355 M4 Ex nA IIC T3	A800	610	130	700	715	736	736	560	140	200	750	254	561	100	80	M24	210	170	28	22
IE2-WE2R 355 MY68 Ex nA IIC T3	A800	610	130	700	715	736	736	560	140	200	750	254	561	100	80	M24	210	170	28	22
IE2-WE2R 355 M6 Ex nA IIC T3	A800	610	130	700	715	736	736	560	140	200	750	254	561	100	80	M24	210	170	28	22
IE2-WE2R 355 MX6 Ex nA IIC T3	A800	610	130	700	715	736	736	560	140	200	750	254	681	100	80	M24	210	170	28	22
IE2-WE2R 355 MX2G Ex nA IIC T3	A800	610	130	700	715	729	729	560	140	200	750	254	-	80	80	M20	170	-	22	-
IE2-WE2R 355 L2G Ex nA IIC T3	A800	610	130	700	715	729	729	630	140	200	750	254	-	80	80	M20	170	-	22	-
IE2-WE2R 355 MX4 Ex nA IIC T3	A800	610	130	700	715	729	729	560	140	200	750	254	681	100	80	M24	210	170	28	22
IE2-WE2R 355 L4 Ex nA IIC T3	A800	610	130	700	715	729	729	630	140	200	750	254	611	100	80	M24	210	170	28	22
IE2-WE2R 355 L8 Ex nA IIC T3	A800	610	130	700	715	729	729	630	140	200	750	254	611	100	80	M24	210	170	28	22

¹⁾ Centre holes to DIN 332-DS ...

Three-phase motors with squirrel-cage rotor for operation in Zone 2 according to EN 60079-15 (EN 60079-7)

Type of explosion protection „n“ (Increased safety „ec“) and for operation in Zones 21 and 22 according to EN 60079-31, Type of explosion protection – Protection by enclosure „tb, tc“, High Efficiency IE2 (VIK Recommendation 1, Three-Phase Asynchronous Motors – Technical Requirements 03.2011)

with surface cooling, type of cooling IC 411
Size 315 to 355

Type of construction IM B35 [IM 2001]

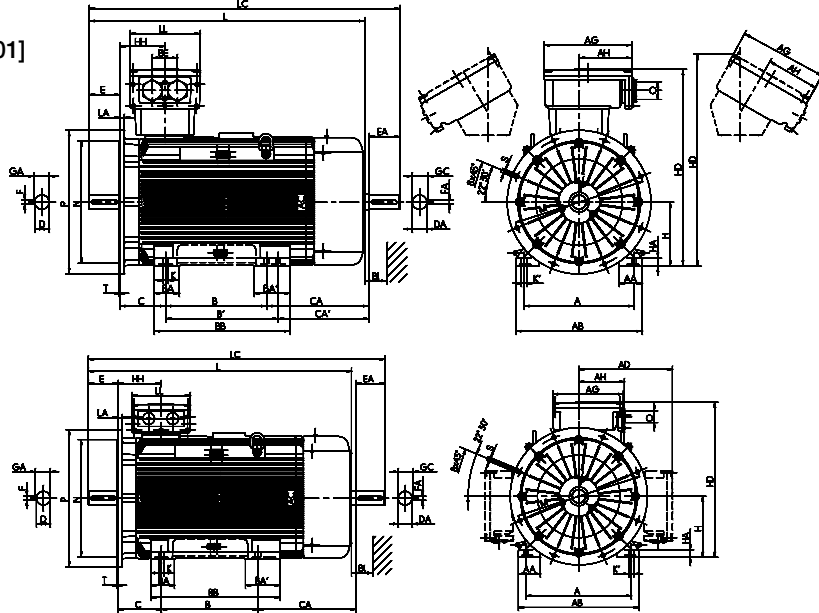

Type designation	GA	GC	H	HA	HD	HD ^{*)}	HD	HH	K	K'	L	L	L	LC	LC	TB Type	AG	LL	AH	TB Type	AG	LL	AH	O	LB	BI
	t	t1	h	c	p	p	VIK p	A	s	s'	k	k	k	k1	k1	Ex e IIC Standard	x	z	-	Ex e IIC VIK	x	z	-	-	-	BI
											(IM V1)	(IM B5)														
IE2-WE1R 315 S2 Ex nA IIC T3	69	69	315	44	731	610	775.5	211	28	35	1050	1160	1050	1218	1218	200 A	282	242	-	400 A-SB	415	340	265	M63 x 1.5	55	8L
IE2-WE1R 315 M2 Ex nA IIC T3	69	69	315	44	731	610	775.5	211	28	35	1105	1215	1105	1273	1273	200 A	282	242	-	400 A-SB	415	340	265	M63 x 1.5	55	8L
IE2-WE1R 315 MX2 Ex nA IIC T3	69	69	315	44	731	610	775.5	211	28	35	1185	1295	1185	1353	1353	200 A	282	242	-	400 A-SB	415	340	265	M63 x 1.5	55	8L
IE2-WE1R 315 MY2 Ex nA IIC T3	69	69	315	44	809	628	995.5	230	28	35	1270	1380	1270	1448	1448	400 A-SB	415	340	265	630 A	496	390	301	M63 x 1.5	55	8L
IE2-WE1R 315 L2 Ex nA IIC T3	69	69	315	44	809	628	995.5	230	28	35	1390	1500	1390	1568	1568	400 A-SB	415	340	265	630 A	496	390	301	M63 x 1.5	55	8L
IE2-WE1R 315 LX2 Ex nA IIC T3	69	69	315	44	809	628	995.5	230	28	35	1510	1620	1510	1688	1688	400 A-SB	415	340	265	630 A	496	390	301	M63 x 1.5	55	8L
IE2-WE1R 315 S4 Ex nA IIC T3	85	74.5	315	44	731	610	775.5	211	28	35	1080	1190	1080	1248	1248	200 A	282	242	-	400 A-SB	415	340	265	M63 x 1.5	55	8L
IE2-WE1R 315 M4 Ex nA IIC T3	85	74.5	315	44	731	610	775.5	211	28	35	1135	1245	1135	1303	1303	200 A	282	242	-	400 A-SB	415	340	265	M63 x 1.5	55	8L
IE2-WE1R 315 MX4 Ex nA IIC T3	85	74.5	315	44	731	610	775.5	211	28	35	1210	1325	1210	1383	1383	200 A	282	242	-	400 A-SB	415	340	265	M63 x 1.5	55	8L
IE2-WE1R 315 MY4 Ex nA IIC T3	85	74.5	315	44	809	628	995.5	230	28	35	1300	1410	1300	1478	1478	400 A-SB	415	340	265	630 A	496	390	301	M63 x 1.5	55	8L
IE2-WE1R 315 L4 Ex nA IIC T3	85	74.5	315	44	809	628	995.5	230	28	35	1420	1530	1420	1598	1598	400 A-SB	415	340	265	630 A	496	390	301	M63 x 1.5	55	8L
IE2-WE1R 315 LX4 Ex nA IIC T3	85	74.5	315	44	809	628	995.5	230	28	35	1540	1650	1540	1718	1718	400 A-SB	415	340	265	630 A	496	390	301	M63 x 1.5	55	8L
IE2-WE1R 315 S6 Ex nA IIC T3	85	74.5	315	44	731	610	775.5	211	28	35	1135	1245	1135	1303	1303	200 A	282	242	-	400 A-SB	415	340	265	M63 x 1.5	55	8L
IE2-WE1R 315 M6 Ex nA IIC T3	85	74.5	315	44	731	610	775.5	211	28	35	1135	1245	1135	1303	1303	200 A	282	242	-	400 A-SB	415	340	265	M63 x 1.5	55	8L
IE2-WE1R 315 MX6 Ex nA IIC T3	85	74.5	315	44	809	628	995.5	230	28	35	1300	1410	1300	1478	1478	400 A-SB	415	340	265	630 A	496	390	301	M63 x 1.5	55	8L
IE2-WE1R 315 MY6 Ex nA IIC T3	85	74.5	315	44	809	628	995.5	230	28	35	1300	1410	1300	1478	1478	400 A-SB	415	340	265	630 A	496	390	301	M63 x 1.5	55	8L
IE2-WE1R 315 L6 Ex nA IIC T3	85	74.5	315	44	809	628	995.5	230	28	35	1420	1530	1420	1598	1598	400 A-SB	415	340	265	630 A	496	390	301	M63 x 1.5	55	8L
IE2-WE1R 315 LX6 Ex nA IIC T3	85	74.5	315	44	809	628	995.5	230	28	35	1420	1530	1420	1598	1598	400 A-SB	415	340	265	630 A	496	390	301	M63 x 1.5	55	8L
IE2-WE1R 315 S8 Ex nA IIC T3	85	74.5	315	44	731	610	775.5	211	28	35	1135	1245	1135	1303	1303	200 A	282	242	-	400 A-SB	415	340	265	M63 x 1.5	55	8L
IE2-WE1R 315 M8 Ex nA IIC T3	85	74.5	315	44	731	610	775.5	211	28	35	1135	1245	1135	1303	1303	200 A	282	242	-	400 A-SB	415	340	265	M63 x 1.5	55	8L
IE2-WE1R 315 MX8 Ex nA IIC T3	85	74.5	315	44	809	628	995.5	230	28	35	1300	1410	1300	1478	1478	400 A-SB	415	340	265	630 A	496	390	301	M63 x 1.5	55	8L
IE2-WE1R 315 MY8 Ex nA IIC T3	85	74.5	315	44	809	628	995.5	230	28	35	1300	1410	1300	1478	1478	400 A-SB	415	340	265	630 A	496	390	301	M63 x 1.5	55	8L
IE2-WE1R 315 L8 Ex nA IIC T3	85	74.5	315	44	809	628	995.5	230	28	35	1420	1530	1420	1598	1598	400 A-SB	415	340	265	630 A	496	390	301	M63 x 1.5	55	8L
IE2-WE1R 315 LX8 Ex nA IIC T3	85	74.5	315	44	809	628	995.5	230	28	35	1420	1530	1420	1598	1598	400 A-SB	415	340	265	630 A	496	390	301	M63 x 1.5	55	8L
IE2-WE2R 355 MY2G Ex nA IIC T3	85	-	355	44	1091	1172	736	250	28	35	1530	1650	1530	-	-	630 A	496	390	301	630 A	496	390	301	M75 x 1.5	60	8L
IE2-WE2R 355 M2G Ex nA IIC T3	85	-	355	44	1091	1172	736	250	28	35	1530	1650	1530	-	-	630 A	496	390	301	630 A	496	390	301	M75 x 1.5	60	8L
IE2-WE2R 355 MY4 Ex nA IIC T3	106	85	355	44	1091	1172	736	250	28	35	1570	1690	1570	1755	1755	630 A	496	390	301	630 A	496	390	301	M75 x 1.5	60	8L
IE2-WE2R 355 M4 Ex nA IIC T3	106	85	355	44	1091	1172	736	250	28	35	1570	1690	1570	1755	1755	630 A	496	390	301	630 A	496	390	301	M75 x 1.5	60	8L
IE2-WE2R 355 MY6 Ex nA IIC T3	106	85	355	44	1091	1172	736	250	28	35	1570	1690	1570	1755	1755	630 A	496	390	301	630 A	496	390	301	M75 x 1.5	60	8L
IE2-WE2R 355 M6 Ex nA IIC T3	106	85	355	44	1091	1172	736	250	28	35	1570	1690	1570	1755	1755	630 A	496	390	301	630 A	496	390	301	M75 x 1.5	60	8L
IE2-WE2R 355 MX6 Ex nA IIC T3	106	85	355	44	1091	1172	736	250	28	35	1690	1810	1690	1875	1875	630 A	496	390	301	630 A	496	390	301	M75 x 1.5	60	8L
IE2-WE2R 355 MX2G Ex nA IIC T3	85	-	355	44	1084	1174	729	327	28	35	1650	1770	1650	-	-	1000 A	615	474	385	1000 A	615	474	385	M75 x 1.5	60	8L
IE2-WE2R 355 L2G Ex nA IIC T3	85	-	355	44	1084	1174	729	327	28	35	1650	1770	1650	-	-	1000 A	615	474	385	1000 A	615	474	385	M75 x 1.5	60	8L
IE2-WE2R 355 MY4 Ex nA IIC T3	106	85	355	44	1084	1174	729	327	28	35	1690	1810	1690	1875	1875	1000 A	615	474	385	1000 A	615	474	385	M75 x 1.5	60	8L
IE2-WE2R 355 L4 Ex nA IIC T3	106	85	355	44	1084	1174	729	327	28	35	1690	1810	1690	1875	1875	1000 A	615	474	385	1000 A	615	474	385	M75 x 1.5	60	8L
IE2-WE2R 355 L8 Ex nA IIC T3	106	85	355	44	1084	1174	729	327	28	35	1690	1810	1690	1875	1875	1000 A	615	474	385	1000 A	615	474	385	M75 x 1.5	60	8L

^{*)} Terminal box inclined left/right

Three-phase motors with squirrel-cage rotor for operation in Zone 2 according to EN 60079-15 (EN 60079-7)

Type of explosion protection „n“ (Increased safety „ec“) and and for operation in Zones 21 and 22 according to EN 60079-31, Type of explosion protection – Protection by enclosure „tb, tc“, High Efficiency IE2 (VIK Recommendation 1, Three-Phase Asynchronous Motors – Technical Requirements 03.2011)

with surface cooling, type of cooling IC 411
Size 80 to 180

Type of construction IM B14 [IM 3601]
Flange dimensions, see page 10/6

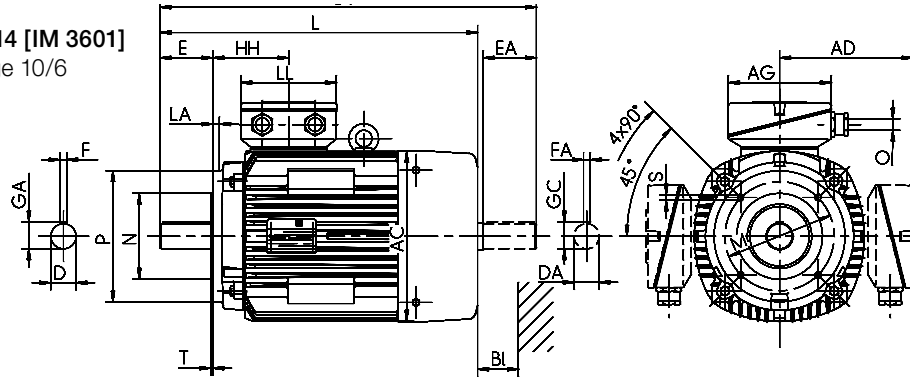

Type designation	A	AA	AB	AC	AD	AD	B	BA	BB	C	CA	D	DA	DB ¹⁾	E	EA	F	FA		
	g1																			
	b	n	f	g	g1	(VIK)	a	m	e	w1	w2	d	d1	l	l1	u	u1			
IE2-W21R 80 K2, 4, 6, 8 Ex nA II T3	C120	C160	125	26	152	157	138	100	-	124	50	80	19	19	M6	40	40	6	6	
IE2-WE(2)1R 80 G2, 4, 6, 8 Ex nA II T3	C120	C160	125	26	152	157	138	100	-	146	50	102	19	19	M6	40	40	6	6	
IE2-WE(2)1R 90 S2, 4, 6, 8 Ex nA II T3	C140	C160	140	40	178	177	146	100	-	130	56	159	24	24	M8	50	50	8	8	
IE2-WE1R 90 L2 Ex nA II T3	C140	C160	140	40	178	177	146	125	-	155	56	134	24	24	M8	50	50	8	8	
IE2-WE1R 90 L4, 6, 8 Ex nA II T3	C140	C160	140	40	178	177	146	125	-	155	56	164	24	24	M8	50	50	8	8	
IE2-WE(2)1R 100 L2, S8 Ex nA II T3	C160	C200	160	42	193	196	155	140	-	175	63	102	28	28	M10	60	60	8	8	
IE2-WE1R 100 L4 Ex nA II T3	C160	C200	160	42	193	196	155	140	-	175	63	136	28	28	M10	60	60	8	8	
IE2-W21R 100 LX6 Ex nA II T3	C160	C200	160	42	193	196	155	140	-	175	63	136	28	28	M10	60	60	8	8	
IE2-WE1R 100 LX4 Ex nA II T3	C160	C200	160	42	193	196	155	140	-	175	63	166	28	28	M10	60	60	8	8	
IE2-WE1R 112 MX2 Ex nA II T3	C160	C200	190	52	225	196	155	140	-	180	70	129	28	28	M10	60	60	8	8	
IE2-WE1R 112 MV2 Ex nA II T3	C160	C200	190	52	225	196	155	140	-	180	70	159	28	28	M10	60	60	8	8	
IE2-WE1R 112 MV6, 8 Ex nA II T3	C160	C200	190	52	225	196	155	140	-	180	70	159	28	28	M10	60	60	8	8	
IE2-WE1R 112 MZ4 Ex nA II T3	C160	C200	190	52	225	196	155	140	-	180	70	199	28	28	M10	60	60	8	8	
IE2-WE1R 112 MZ6 Ex nA II T3	C160	C200	190	52	225	196	155	140	-	180	70	199	28	28	M10	60	60	8	8	
IE2-WE1R 112 M2 Ex nA IIC T3	C160	C200	190	45	226	217	220	220	140	42	172	70	192	28	28	M10	60	60	8	8
IE2-WE1R 112 M4 Ex nA IIC T3	C160	C200	190	45	226	217	220	220	140	42	172	70	192	28	28	M10	60	60	8	8
IE2-WE1R 112 M6 Ex nA IIC T3	C160	C200	190	45	226	217	220	220	140	42	172	70	192	28	28	M10	60	60	8	8
IE2-WE1R 132 S2T Ex nA II T3	C200	C250	216	52	257	196	155	140	-	180	89	159	38	28	M12	80	60	10	8	
IE2-WE1R 132 S2 Ex nA IIC T3	C160	C200	216	50	256	217	220	220	140	53	180	89	173	38	32	M12	80	80	10	10
IE2-WE1R 132 SX2 Ex nA IIC T3	C200	C250	216	50	256	258	246	246	140	53	180	89	176	38	32	M12	80	80	10	10
IE2-WE1R 132 S4 Ex nA IIC T3	C200	C250	216	50	256	258	246	246	140	53	180	89	186	38	32	M12	80	80	10	10
IE2-WE1R 132 S6 Ex nA IIC T3	C160	C200	216	50	256	217	220	220	140	53	180	89	173	38	32	M12	80	80	10	10
IE2-WE1R 132 M4 Ex nA IIC T3	C200	C250	216	50	256	258	246	246	178	53	218	89	186	38	38	M12	80	80	10	10
IE2-WE1R 132 M6 Ex nA IIC T3	C200	C250	216	50	256	258	246	246	178	53	218	89	138	38	32	M12	80	80	10	10
IE2-WE1R 132 MX6 Ex nA IIC T3	C200	C250	216	50	256	258	246	246	178	53	218	89	186	38	38	M12	80	80	10	10
IE2-WE2R 132 S4 Ex nA IIC T3	C160	C200	216	50	256	217	220	220	140	53	180	89	223	38	32	M12	80	80	10	10
IE2-WE2R 132 M6 Ex nA IIC T3	C160	C200	216	50	256	217	220	220	178	53	218	89	135	38	32	M12	80	80	10	10
IE2-WE2R 132 M8 Ex nA IIC T3	C160	C200	216	50	256	217	220	220	178	53	218	89	135	38	32	M12	80	80	10	10
IE2-WE1R 160 M2 Ex nA IIC T3	C250	C300	254	55	296	313	249	275	210	60	257	108	148	42	42	M16	110	110	12	12
IE2-WE1R 160 M4 Ex nA IIC T3	C250	C300	254	55	296	313	249	275	210	60	257	108	148	42	42	M16	110	110	12	12
IE2-WE1R 160 M8 Ex nA IIC T3	C200	C250	254	55	296	258	256	256	210	60	257	108	135	42	38	M16	110	80	12	10
IE2-WE1R 160 M6 Ex nA IIC T3	C250	C300	254	55	296	313	249	275	210	60	257	108	148	42	42	M16	110	110	12	12
IE2-WE1R 160 MX2 Ex nA IIC T3	C250	C300	254	55	296	313	249	275	210	56	257	108	186	42	42	M16	110	110	12	12
IE2-WE1R 160 L2 Ex nA IIC T3	C250	C300	254	55	296	313	249	275	254	60	301	108	142	42	42	M16	110	110	12	12
IE2-WE1R 160 L4 Ex nA IIC T3	C250	C300	254	55	296	313	249	275	254	60	301	108	200	42	42	M16	110	110	12	12
IE2-WE1R 160 L6 Ex nA IIC T3	C250	C300	254	55	296	313	249	275	254	60	301	108	142	42	42	M16	110	110	12	12
IE2-WE2R 160 M4 Ex nA IIC T3	C200	C250	254	55	296	258	256	256	210	60	257	108	185	42	38	M16	110	80	12	10
IE2-WE2R 160 L4 Ex nA IIC T3	C250	C300	254	55	296	313	249	275	254	60	301	108	192	42	42	M16	110	110	12	12
IE2-WE2R 160 M6 Ex nA IIC T3	C200	C250	254	55	296	258	256	256	210	60	257	108	185	42	38	M16	110	80	12	10
IE2-WE2R 160 L6 Ex nA IIC T3	C250	C300	254	55	296	313	249	275	254	60	301	108	192	42	42	M16	110	110	12	12
IE2-WE2R 160 MX8 Ex nA IIC T3	C200	C250	254	55	296	258	256	256	210	60	257	108	185	42	38	M16	110	80	12	10
IE2-WE2R 180 L6 Ex nA IIC T3	C300		279	62	328	313	249	275	279	65	326	121	154	48	42	M16	110	110	14	12
IE2-WE2R 180 L8 Ex nA IIC T3	C300		279	62	328	313	256	256	279	65	326	121	154	48	42	M16	110	110	14	12

¹⁾ Centre holes to DIN 332-DS ...

Three-phase motors with squirrel-cage rotor for operation in Zone 2 according to EN 60079-15 (EN 60079-7)

Type of explosion protection „n“ (Increased safety „ec“) and and for operation in Zones 21 and 22 according to EN 60079-31, Type of explosion protection – Protection by enclosure „tb, tc“, High Efficiency IE2 (VIK Recommendation 1, Three-Phase Asynchronous Motors – Technical Requirements 03.2011)

with surface cooling, type of cooling IC 411
Size 80 to 180

Type of construction IM B34 [IM 2101]
Flange dimensions, see page 10/6

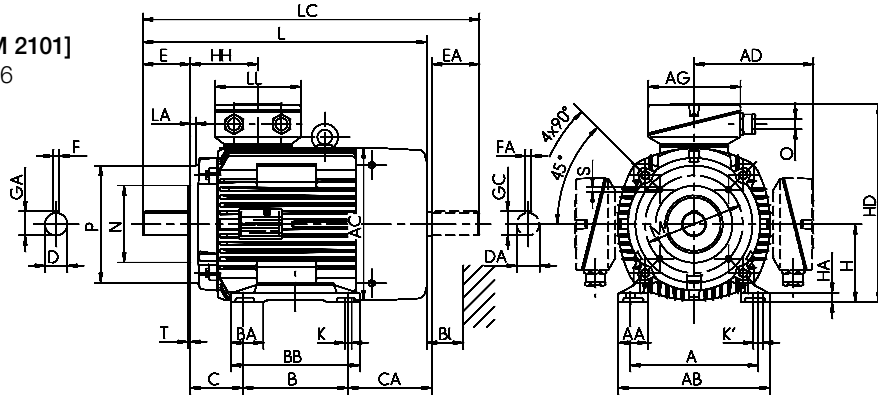

Type designation	GA	GC	H	HA	HD	HD ^{**)}	HD	HH	K	K'	L	L	L	LC	LC	TB Type	AG	LL	TB Type	AG	LL	O	LB	BI
	t	t1	h	c	p	p		A	s	s'	k	k	k1	k1	k1	Ex e IIC Standard	x	z	Ex e IIC VIK	x	z	-	-	BI
											(B3, VIK)	(IM V1)	(IM B5)	(IM B5)	(IM B5)									
IE2-W21R 80 K2, 4, 6, 8 Ex nA II T3	21.5	21.5	80	9	218	***)	79	10	10	267	296	267	310	310	VIK16_M20			VIK16_M20					16	4L
IE2-WE(2)1R 80 G2, 4, 6, 8 Ex nA II T3	21.5	21.5	80	9	218	***)	79	10	10	289	318	289	332	332	VIK16_M20			VIK16_M20					16	4L
IE2-WE(2)1R 90 S2, 4, 6, 8 Ex nA II T3	27	27	90	10.5	236	***)	84	10	10	323	390	361	376	415	VIK16_M25			VIK16_M25					18	4L
IE2-WE1R 90 L2 Ex nA II T3	27	27	90	10.5	236	***)	84	10	10	323	390	361	376	415	VIK16_M25			VIK16_M25					18	4L
IE2-WE1R 90 L4, 6, 8 Ex nA II T3	27	27	90	10.5	236	***)	84	10	10	353	420	391	406	445	VIK16_M25			VIK16_M25					18	4L
IE2-WE(2)1R 100 L2, S8 Ex nA II T3	31	31	100	13	255	***)	86	12	12	359	388	359	425	425	VIK16_M25			VIK16_M25					20	4L
IE2-WE1R 100 L4 Ex nA II T3	31	31	100	13	255	***)	86	12	12	393	422	393	459	459	VIK16_M25			VIK16_M25					20	4L
IE2-W21R 100 LX6 Ex nA II T3	31	31	100	13	255	***)	86	12	12	393	422	393	459	459	VIK16_M25			VIK16_M25					20	4L
IE2-WE1R 100 LX4 Ex nA II T3	31	31	100	13	255	***)	86	12	12	423	452	423	489	489	VIK16_M25			VIK16_M25					20	4L
IE2-WE1R 112 MX2 Ex nA II T3	31	31	112	18	267	***)	86	12	12	393	422	393	459	459	VIK16_M25			VIK16_M25					20	4L
IE2-WE1R 112 M4 Ex nA IIC T3	31	31	112	18	267	***)	86	12	12	423	452	423	489	489	VIK16_M25			VIK16_M25					20	4L
IE2-WE1R 112 MV6, 8 Ex nA II T3	31	31	112	18	267	***)	86	12	12	423	452	423	489	489	VIK16_M25			VIK16_M25					20	4L
IE2-WE1R 112 M24 Ex nA II T3	31	31	112	18	267	***)	86	12	12	463	492	463	529	529	VIK16_M25			VIK16_M25					20	4L
IE2-WE1R 112 M26 Ex nA II T3	31	31	112	18	267	***)	86	12	12	463	492	463	529	529	VIK16_M25			VIK16_M25					20	4L
IE2-WE1R 112 M2 Ex nA IIC T3	31	31	112	15	333	237	333	108	12	12	459	499	459	522	522	25 A	143 134	25 AV	143	134	M32 x 1.5	35	4L	
IE2-WE1R 112 M4 Ex nA IIC T3	31	31	112	15	333	237	333	108	12	12	459	499	459	522	522	25 A	143 134	25 AV	143	134	M32 x 1.5	35	4L	
IE2-WE1R 112 M6 Ex nA IIC T3	31	31	112	15	333	237	333	108	12	12	459	499	459	522	522	25 A	143 134	25 AV	143	134	M32 x 1.5	35	4L	
IE2-WE1R 132 S2T Ex nA IIC T3	41	31	132	18	287	***)	105	12	12	462	491	462	528	528	VIK16_M32			VIK16_M32					20	4L
IE2-WE1R 132 S2 Ex nA IIC T3	41	35	132	16	353	257	353	108	12	12	479	519	479	562	562	25 A	143 134	25 AV	143	134	M32 x 1.5	35	4L	
IE2-WE1R 132 SX2 Ex nA IIC T3	41	41	132	15	374	279	374	114	12	12	481	521	481	565	565	25 A	143 134	25 AV	143	134	M32 x 1.5	35	4L	
IE2-WE1R 132 S4 Ex nA IIC T3	41	41	132	15	374	279	374	114	12	12	529	569	529	613	613	25 A	143 134	25 AV	143	134	M32 x 1.5	35	4L	
IE2-WE1R 132 S6 Ex nA IIC T3	41	35	132	16	353	257	353	108	12	12	479	519	479	562	562	25 A	143 134	25 AV	143	134	M32 x 1.5	35	4L	
IE2-WE1R 132 M4 Ex nA IIC T3	41	41	132	15	374	279	374	114	12	12	529	569	529	613	613	25 A	143 134	25 AV	143	134	M32 x 1.5	35	4L	
IE2-WE1R 132 M6 Ex nA IIC T3	41	41	132	16	374	279	374	114	12	12	481	521	481	565	565	25 A	143 134	25 AV	143	134	M32 x 1.5	35	4L	
IE2-WE1R 132 MX6 Ex nA IIC T3	41	41	132	15	374	279	374	114	12	12	529	569	529	613	613	25 A	143 134	25 AV	143	134	M32 x 1.5	35	4L	
IE2-WE2R 132 S4 Ex nA IIC T3	41	35	132	16	353	257	353	108	12	12	529	569	529	612	612	25 A	143 134	25 AV	143	134	M32 x 1.5	35	4L	
IE2-WE2R 132 M6 Ex nA IIC T3	41	35	132	16	353	257	353	108	12	12	529	569	529	612	612	25 A	143 134	25 AV	143	134	M32 x 1.5	35	4L	
IE2-WE2R 132 M8 Ex nA IIC T3	41	35	132	16	353	257	353	108	12	12	529	569	529	612	612	25 A	143 134	25 AV	143	134	M32 x 1.5	35	4L	
IE2-WE1R 160 M2 Ex nA IIC T3	45	45	160	18	409	336	435	138	15	20	571	611	571	686	686	63 A	184 172	100/63 AV	223	214	M40 x 1.5	35	4L	
IE2-WE1R 160 M4 Ex nA IIC T3	45	45	160	18	409	336	435	138	15	20	571	611	571	686	686	63 A	184 172	100/63 AV	223	214	M40 x 1.5	35	4L	
IE2-WE1R 160 M8 Ex nA IIC T3	45	41	160	18	417	307	417	114	15	15	559	599	559	643	643	25 A	143 134	25 AV	143	134	M32 x 1.5	35	4L	
IE2-WE1R 160 M6 Ex nA IIC T3	45	45	160	18	409	336	435	138	15	20	571	611	571	686	686	63 A	184 172	100/63 AV	223	214	M40 x 1.5	35	4L	
IE2-WE1R 160 MX2 Ex nA IIC T3	45	45	160	18	409	336	435	138	15	20	609	649	609	724	724	63 A	184 172	100/63 AV	223	214	M40 x 1.5	35	4L	
IE2-WE1R 160 L2 Ex nA IIC T3	45	45	160	18	409	336	435	138	15	20	609	649	609	724	724	63 A	184 172	100/63 AV	223	214	M40 x 1.5	35	4L	
IE2-WE1R 160 L4 Ex nA IIC T3	45	45	160	18	409	336	435	138	15	20	667	-	667	783	783	63 A	184 172	100/63 AV	223	214	M40 x 1.5	35	4L	
IE2-WE1R 160 L6 Ex nA IIC T3	45	45	160	18	409	336	435	138	15	20	609	649	609	724	724	63 A	184 172	100/63 AV	223	214	M40 x 1.5	35	4L	
IE2-WE2R 160 M4 Ex nA IIC T3	45	41	160	18	417	307	417	114	15	15	609	649	609	693	693	25 A	143 134	25 AV	143	134	M32 x 1.5	35	4L	
IE2-WE2R 160 L4 Ex nA IIC T3	45	45	160	18	409	336	435	138	15	20	659	699	659	774	774	63 A	184 172	100/63 AV	223	214	M40 x 1.5	35	4L	
IE2-WE2R 160 M6 Ex nA IIC T3	45	41	160	18	417	307	417	114	15	15	609	649	609	693	693	25 A	143 134	25 AV	143	134	M32 x 1.5	35	4L	
IE2-WE2R 160 L6 Ex nA IIC T3	45	45	160	18	409	336	435	138	15	20	659	699	659	774	774	63 A	184 172	100/63 AV	223	214	M40 x 1.5	35	4L	
IE2-WE2R 160 MX8 Ex nA IIC T3	45	41	160	18	417	307	417	114	15	15	609	649	609	693	693	25 A	143 134	25 AV	143	134	M32 x 1.5	35	4L	
IE2-WE2R 180 L6 Ex nA IIC T3	51.5	45	180	20	429	356	455	138	15	20	659	699	659	774	774	63 A	184 172	100/63 AV	223	214	M40 x 1.5	35	4L	
IE2-WE2R 180 L8 Ex nA IIC T3	51.5	45	180	20	429	356	455	138	15	20	659	699	659	774	774	63 A	184 172	100/63 AV	223	214	M40 x 1.5	35	4L	

<sup>**) Terminal box inclined left/right
^{***) upon request}</sup>

Three-phase motors with squirrel-cage rotor for operation in Zone 2 according to EN 60079-15 (EN 60079-7)

Type of explosion protection „n“ (Increased safety „ec“) and and for operation in Zones 21 and 22 according to EN 60079-31, Type of explosion protection – Protection by enclosure „tb, tc“, High Efficiency IE2 (VIK Recommendation 1, Three-Phase Asynchronous Motors – Technical Requirements 03.2011)

with surface cooling, type of cooling IC 411
Size 80 to 200

Type of construction IM B5 [IM 3001], Type of construction IM V1 [IM 3011]

Flange dimensions, see page 10/6

Type designation	Flange size	AC	AD	AD	D	DA	DB ^{*)}	E	EA	F	FA	GA	GC	H	HH	L	L	L
		g	g1	g1 (VIK)	d	d1		l	l1	u	u1	t	t1	h	A	k	k	k
																(IM V1)	(IM B5)	
IE2-W21R 80 K2, 4, 6, 8 Ex nA II T3	A200	157	138		19	19	M6	40	40	6	6	21.5	21.5	80	79	267	296	267
IE2-WE(2)1R 80 G2, 4, 6, 8 Ex nA II T3	A200	157	138		19	19	M6	40	40	6	6	21.5	21.5	80	79	289	318	289
IE2-WE(2)1R 90 S2, 4, 6, 8 Ex nA II T3	A200	177	146		24	24	M8	50	50	8	8	27	27	90	84	323	390	361
IE2-WE1R 90 L2 Ex nA II T3	A200	177	146		24	24	M8	50	50	8	8	27	27	90	84	323	390	361
IE2-WE1R 90 L4, 6, 8 Ex nA II T3	A200	177	146		24	24	M8	50	50	8	8	27	27	90	84	353	420	391
IE2-WE(2)1R 100 L2, S8 Ex nA II T3	A250	196	155		28	28	M10	60	60	8	8	31	31	100	86	359	388	359
IE2-WE1R 100 L4 Ex nA II T3	A250	196	155		28	28	M10	60	60	8	8	31	31	100	86	393	422	393
IE2-W21R 100 LX6 Ex nA II T3	A250	196	155		28	28	M10	60	60	8	8	31	31	100	86	393	422	393
IE2-WE1R 100 LX4 Ex nA II T3	A250	196	155		28	28	M10	60	60	8	8	31	31	100	86	423	452	423
IE2-WE1R 112 MX2 Ex nA II T3	A250	196	155		28	28	M10	60	60	8	8	31	31	112	86	393	422	393
IE2-WE1R 112 MV2 Ex nA II T3	A250	196	155		28	28	M10	60	60	8	8	31	31	112	86	423	452	423
IE2-WE1R 112 MV6, 8 Ex nA II T3	A250	196	155		28	28	M10	60	60	8	8	31	31	112	86	423	452	423
IE2-WE1R 112 MZ4 Ex nA II T3	A250	196	155		28	28	M10	60	60	8	8	31	31	112	86	463	492	463
IE2-WE1R 112 MZ6 Ex nA II T3	A250	196	155		28	28	M10	60	60	8	8	31	31	112	86	463	492	463
IE2-WE1R 112 M2 Ex nA IIC T3	A250	217	220	220	28	28	M10	60	60	8	8	31	31	112	108	459	499	459
IE2-WE1R 112 M4 Ex nA IIC T3	A250	217	220	220	28	28	M10	60	60	8	8	31	31	112	108	459	499	459
IE2-WE1R 112 M6 Ex nA IIC T3	A250	217	220	220	28	28	M10	60	60	8	8	31	31	112	108	459	499	459
IE2-WE1R 132 S2T Ex nA II T3	A300	196	155		38	28	M12	80	60	10	8	41	31	132	105	462	491	462
IE2-WE1R 132 S2 Ex nA IIC T3	A300	217	220	220	38	32	M12	80	80	10	10	41	35	132	108	479	519	479
IE2-WE1R 132 SX2 Ex nA IIC T3	A300	258	246	246	38	32	M12	80	80	10	10	41	41	132	114	481	521	481
IE2-WE1R 132 S4 Ex nA IIC T3	A300	258	246	246	38	32	M12	80	80	10	10	41	41	132	114	529	569	529
IE2-WE1R 132 S6 Ex nA IIC T3	A300	217	220	220	38	32	M12	80	80	10	10	41	35	132	108	479	519	479
IE2-WE1R 132 M4 Ex nA IIC T3	A300	258	246	246	38	38	M12	80	80	10	10	41	41	132	114	529	569	529
IE2-WE1R 132 M6 Ex nA IIC T3	A300	258	246	246	38	32	M12	80	80	10	10	41	41	132	114	481	521	481
IE2-WE1R 132 MX6 Ex nA IIC T3	A300	258	246	246	38	38	M12	80	80	10	10	41	41	132	114	529	569	529
IE2-WE2R 132 S4 Ex nA IIC T3	A300	217	220	220	38	32	M12	80	80	10	10	41	35	132	108	529	569	529
IE2-WE2R 132 M6 Ex nA IIC T3	A300	217	220	220	38	32	M12	80	80	10	10	41	35	132	108	529	569	529
IE2-WE2R 132 M8 Ex nA IIC T3	A300	217	220	220	38	32	M12	80	80	10	10	41	35	132	108	529	569	529
IE2-WE1R 160 M2 Ex nA IIC T3	A350	313	249	275	42	42	M16	110	110	12	12	45	45	160	138	571	611	571
IE2-WE1R 160 M4 Ex nA IIC T3	A350	313	249	275	42	42	M16	110	110	12	12	45	45	160	138	571	611	571
IE2-WE1R 160 M8 Ex nA IIC T3	A350	258	256	256	42	38	M16	110	80	12	10	45	41	160	114	559	599	559
IE2-WE1R 160 M6 Ex nA IIC T3	A350	313	249	275	42	42	M16	110	110	12	12	45	45	160	138	571	611	571
IE2-WE1R 160 MX2 Ex nA IIC T3	A350	313	249	275	42	42	M16	110	110	12	12	45	45	160	138	609	649	609
IE2-WE1R 160 L2 Ex nA IIC T3	A350	313	249	275	42	42	M16	110	110	12	12	45	45	160	138	609	649	609
IE2-WE1R 160 L4 Ex nA IIC T3	A350	313	249	275	42	42	M16	110	110	12	12	45	45	160	138	667	-	667
IE2-WE1R 160 L6 Ex nA IIC T3	A350	313	249	275	42	42	M16	110	110	12	12	45	45	160	138	609	649	609
IE2-WE2R 160 M4 Ex nA IIC T3	A350	258	256	256	42	38	M16	110	80	12	10	45	41	160	114	609	649	609
IE2-WE2R 160 L4 Ex nA IIC T3	A350	313	249	275	42	42	M16	110	110	12	12	45	45	160	138	659	699	659
IE2-WE2R 160 M6 Ex nA IIC T3	A350	258	256	256	42	38	M16	110	80	12	10	45	41	160	114	609	649	609
IE2-WE2R 160 L6 Ex nA IIC T3	A350	313	249	275	42	42	M16	110	110	12	12	45	45	160	138	659	699	659
IE2-WE2R 160 MX8 Ex nA IIC T3	A350	258	256	256	42	38	M16	110	80	12	10	45	41	160	114	609	649	609
IE2-WE1R 180 M2 Ex nA IIC T3	A350	351	268	294	48	48	M16	110	110	14	14	51.5	51.5	180	147	635	675	635
IE2-WE1R 180 M4 Ex nA IIC T3	A350	351	268	294	48	48	M16	110	110	14	14	51.5	51.5	180	147	680	720	680
IE2-WE1R 180 L4 Ex nA IIC T3	A350	351	268	294	48	48	M16	110	110	14	14	51.5	51.5	180	147	680	720	680
IE2-WE1R 180 L6 Ex nA IIC T3	A350	351	268	294	48	48	M16	110	110	14	14	51.5	51.5	180	147	680	720	680
IE2-WE2R 180 M4 Ex nA IIC T3	A350	351	268	294	48	48	M16	110	110	14	14	51.5	51.5	180	147	635	675	635
IE2-WE2R 180 L6 Ex nA IIC T3	A350	313	249	275	48	42	M16	110	110	14	12	51.5	45	180	138	659	699	659
IE2-WE2R 180 L8 Ex nA IIC T3	A350	313	256	256	48	42	M16	110	110	14	12	51.5	45	180	138	659	699	659
IE2-WE1R 200 L2 Ex nA IIC T3	A400	351	268	294	55	48	M20	110	110	16	14	59	51.5	200	147	680	720	680
IE2-WE1R 200 LX2 Ex nA IIC T3	A400	351	268	294	55	48	M20	110	110	16	14	59	51.5	200	147	730	-	730
IE2-WE1R 200 L4 Ex nA IIC T3	A400	390	311	375	55	55	M20	110	110	16	16	59	59	200	168	727	767	727
IE2-WE1R 200 LX6 Ex nA IIC T3	A400	390	311	375	55	55	M20	110	110	16	16	59	59	200	168	727	767	727
IE2-WE1R 200 L6 Ex nA IIC T3	A400	351	268	294	55	48	M20	110	110	16	14	59	51.5	200	147	680	720	680
IE2-WE2R 200 LX2 Ex nA IIC T3	A400	351	268	294	55	48	M20	110	110	16	14	59	51.5	200	147	730	770	730
IE2-WE2R 200 LX6 Ex nA IIC T3	A400	351	268	294	55	48	M20	110	110	16	14	59	51.5	200	147	730	770	730

^{*)} Centre holes to DIN 332-DS ...

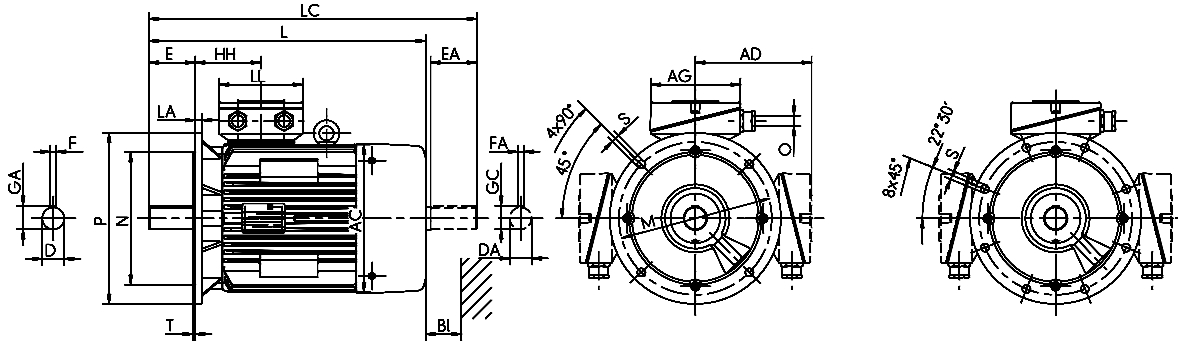

Type designation	LC k1	LC k1 (IM B5)	TB Type Ex e IIC Standard	AG x	LL z	TB Type Ex e IIC VIK	AG x	LL z	AH -	O -	LB	BI
IE2-W21R 80 K2, 4, 6, 8 Ex nA II T3	310	310	VIK16_M20			VIK16_M20					16	4L
IE2-WE(2)1R 80 G2, 4, 6, 8 Ex nA II T3	332	332	VIK16_M20			VIK16_M20					16	4L
IE2-WE(2)1R 90 S2, 4, 6, 8 Ex nA II T3	376	415	VIK16_M25			VIK16_M25					18	4L
IE2-WE1R 90 L2 Ex nA II T3	376	415	VIK16_M25			VIK16_M25					18	4L
IE2-WE1R 90 L4, 6, 8 Ex nA II T3	406	445	VIK16_M25			VIK16_M25					18	4L
IE2-WE(2)1R 100 L2, S8 Ex nA II T3	425	425	VIK16_M25			VIK16_M25					20	4L
IE2-WE1R 100 L4 Ex nA II T3	459	459	VIK16_M25			VIK16_M25					20	4L
IE2-W21R 100 LX6 Ex nA II T3	459	459	VIK16_M25			VIK16_M25					20	4L
IE2-WE1R 100 LX4 Ex nA II T3	489	489	VIK16_M25			VIK16_M25					20	4L
IE2-WE1R 112 MX2 Ex nA II T3	459	459	VIK16_M25			VIK16_M25					20	4L
IE2-WE1R 112 MV2 Ex nA II T3	489	489	VIK16_M25			VIK16_M25					20	4L
IE2-WE1R 112 MV6, 8 Ex nA II T3	489	489	VIK16_M25			VIK16_M25					20	4L
IE2-WE1R 112 MZ4 Ex nA II T3	529	529	VIK16_M25			VIK16_M25					20	4L
IE2-WE1R 112 MZ6 Ex nA II T3	529	529	VIK16_M25			VIK16_M25					20	4L
IE2-WE1R 112 M2 Ex nA IIC T3	528	528	VIK16_M32			VIK16_M32					20	4L
IE2-WE1R 112 M4 Ex nA IIC T3	522	522	25 A	143	134	25 AV	143	134	-	M32 x 1.5	35	4L
IE2-WE1R 112 M6 Ex nA IIC T3	522	522	25 A	143	134	25 AV	143	134	-	M32 x 1.5	35	4L
IE2-WE1R 132 S2T Ex nA II T3	522	522	25 A	143	134	25 AV	143	134	-	M32 x 1.5	35	4L
IE2-WE1R 132 S2 Ex nA IIC T3	562	562	25 A	143	134	25 AV	143	134	-	M32 x 1.5	35	4L
IE2-WE1R 132 SX2 Ex nA IIC T3	565	565	25 A	143	134	25 AV	143	134	-	M32 x 1.5	35	4L
IE2-WE1R 132 S4 Ex nA IIC T3	613	613	25 A	143	134	25 AV	143	134	-	M32 x 1.5	35	4L
IE2-WE1R 132 S6 Ex nA IIC T3	562	562	25 A	143	134	25 AV	143	134	-	M32 x 1.5	35	4L
IE2-WE1R 132 M4 Ex nA IIC T3	613	613	25 A	143	134	25 AV	143	134	-	M32 x 1.5	35	4L
IE2-WE1R 132 M6 Ex nA IIC T3	565	565	25 A	143	134	25 AV	143	134	-	M32 x 1.5	35	4L
IE2-WE1R 132 MX6 Ex nA IIC T3	613	613	25 A	143	134	25 AV	143	134	-	M32 x 1.5	35	4L
IE2-WE2R 132 S4 Ex nA IIC T3	612	612	25 A	143	134	25 AV	143	134	-	M32 x 1.5	35	4L
IE2-WE2R 132 M6 Ex nA IIC T3	612	612	25 A	143	134	25 AV	143	134	-	M32 x 1.5	35	4L
IE2-WE2R 132 M8 Ex nA IIC T3	612	612	25 A	143	134	25 AV	143	134	-	M32 x 1.5	35	4L
IE2-WE1R 160 M2 Ex nA IIC T3	686	686	63 A	184	172	100/63 AV	223	214	-	M40 x 1.5	35	4L
IE2-WE1R 160 M4 Ex nA IIC T3	686	686	63 A	184	172	100/63 AV	223	214	-	M40 x 1.5	35	4L
IE2-WE1R 160 M8 Ex nA IIC T3	643	643	25 A	143	134	25 AV	143	134	-	M32 x 1.5	35	4L
IE2-WE1R 160 M6 Ex nA IIC T3	686	686	63 A	184	172	100/63 AV	223	214	-	M40 x 1.5	35	4L
IE2-WE1R 160 MX2 Ex nA IIC T3	724	724	63 A	184	172	100/63 AV	223	214	-	M40 x 1.5	35	4L
IE2-WE1R 160 L2 Ex nA IIC T3	724	724	63 A	184	172	100/63 AV	223	214	-	M40 x 1.5	35	4L
IE2-WE1R 160 L4 Ex nA IIC T3	783	783	63 A	184	172	100/63 AV	223	214	-	M40 x 1.5	35	4L
IE2-WE1R 160 L6 Ex nA IIC T3	724	724	63 A	184	172	100/63 AV	223	214	-	M40 x 1.5	35	4L
IE2-WE2R 160 M4 Ex nA IIC T3	693	693	25 A	143	134	25 AV	143	134	-	M32 x 1.5	35	4L
IE2-WE2R 160 L4 Ex nA IIC T3	774	774	63 A	184	172	100/63 AV	223	214	-	M40 x 1.5	35	4L
IE2-WE2R 160 M6 Ex nA IIC T3	693	693	25 A	143	134	25 AV	143	134	-	M32 x 1.5	35	4L
IE2-WE2R 160 L6 Ex nA IIC T3	774	774	63 A	184	172	100/63 AV	223	214	-	M40 x 1.5	35	4L
IE2-WE2R 160 MX8 Ex nA IIC T3	693	693	25 A	143	134	25 AV	143	134	-	M32 x 1.5	35	4L
IE2-WE1R 180 M2 Ex nA IIC T3	751	751	63 A	184	172	100/63 AV	223	214	-	M40 x 1.5	35	4L
IE2-WE1R 180 M4 Ex nA IIC T3	796	796	63 A	184	172	100/63 AV	223	214	-	M40 x 1.5	35	4L
IE2-WE1R 180 L4 Ex nA IIC T3	796	796	63 A	184	172	100/63 AV	223	214	-	M40 x 1.5	35	4L
IE2-WE1R 180 L6 Ex nA IIC T3	796	796	63 A	184	172	100/63 AV	223	214	-	M40 x 1.5	35	4L
IE2-WE2R 180 M4 Ex nA IIC T3	751	751	63 A	184	172	100/63 AV	223	214	-	M40 x 1.5	35	4L
IE2-WE2R 180 L6 Ex nA IIC T3	774	774	63 A	184	172	100/63 AV	223	214	-	M40 x 1.5	35	4L
IE2-WE2R 180 L8 Ex nA IIC T3	774	774	63 A	184	172	100/63 AV	223	214	-	M40 x 1.5	35	4L
IE2-WE1R 200 L2 Ex nA IIC T3	796	796	63 A	184	172	100/63 AV	223	214	-	M50 x 1.5	35	4L
IE2-WE1R 200 LX2 Ex nA IIC T3	846	846	63 A	184	172	100/63 AV	223	214	-	M50 x 1.5	35	4L
IE2-WE1R 200 L4 Ex nA IIC T3	851	851	100 A	222	214	200 A-SB	335	270	200	M50 x 1.5	35	4L
IE2-WE1R 200 LX6 Ex nA IIC T3	851	851	100 A	222	214	200 A-SB	335	270	200	M50 x 1.5	35	4L
IE2-WE1R 200 L6 Ex nA IIC T3	796	796	63 A	184	172	100/63 AV	223	214	-	M50 x 1.5	35	4L
IE2-WE2R 200 LX2 Ex nA IIC T3	846	846	63 A	184	172	100/63 AV	223	214	-	M50 x 1.5	35	4L
IE2-WE2R 200 LX6 Ex nA IIC T3	846	846	63 A	184	172	100/63 AV	223	214	-	M50 x 1.5	35	4L

Three-phase motors with squirrel-cage rotor for operation in Zone 2 according to EN 60079-15 (EN 60079-7)

Type of explosion protection „n“ (Increased safety „ec“) and and for operation in Zones 21 and 22 according to EN 60079-31, Type of explosion protection – Protection by enclosure „tb, tc“, High Efficiency IE2 (VIK Recommendation 1, Three-Phase Asynchronous Motors – Technical Requirements 03.2011)

with surface cooling, type of cooling IC 411
Size 225 to 280

Type of construction IM B5 [IM 3001]

Type of construction IM V1 [IM 3011]

Flange dimensions, see page 10/6

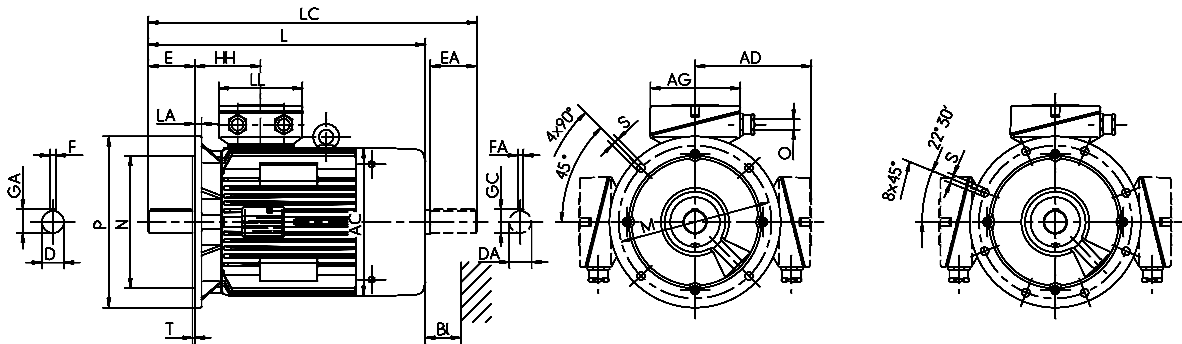

Type designation	Flange size	AC	AD	AD	D	DA	DB ¹⁾	E	EA	F	FA	GA	GC	H	HH	L	L	L
		g	g1	g1 (VIK)	d	d1		l	l1	u	u1	t	t1	h	A	k	k	k
																	(IM V1)	(IM B5)
IE2-WE1R 225 M2 Ex nA IIC T3	A450	390	311	375	55	55	M20	110	110	16	16	59	59	225	168	767	807	767
IE2-WE1R 225 S4 Ex nA IIC T3	A450	390	311	375	60	55	M20	140	110	18	16	64	59	225	168	797	837	797
IE2-WE1R 225 M4 Ex nA IIC T3	A450	440	324	406	60	55	M20	140	110	18	16	64	59	225	177	862	947	862
IE2-WE1R 225 S8 Ex nA IIC T3	A450	390	311	375	60	55	M20	140	110	18	16	64	59	225	168	757	797	757
IE2-WE1R 225 M6 Ex nA IIC T3	A450	440	324	406	60	55	M20	140	110	18	16	64	59	225	177	862	947	862
IE2-WE1R 225 M8 Ex nA IIC T3	A450	440	324	406	60	55	M20	140	110	18	16	64	59	225	177	862	947	862
IE2-WE2R 225 M4 Ex nA IIC T3	A450	390	311	375	60	55	M20	140	110	18	16	64	59	225	168	847	887	847
IE2-WE2R 225 M6 Ex nA IIC T3	A450	390	311	375	60	55	M20	140	110	18	16	64	59	225	168	797	837	797
IE2-WE2R 225 S8 Ex nA IIC T3	A450	390	311	375	60	55	M20	140	110	18	16	64	59	225	168	797	837	797
IE2-WE2R 225 M8 Ex nA IIC T3	A450	390	311	375	60	55	M20	140	110	18	16	64	59	225	168	797	837	797
IE2-WE1R 250 M2 Ex nA IIC T3	A550	440	362	406	60	55	M20	140	110	18	16	64	59	250	177	862	947	862
IE2-WE1R 250 M4 Ex nA IIC T3	A550	490	386	403	65	55	M20	140	110	18	16	69	59	250	206	924	1009	924
IE2-WE1R 250 M6 Ex nA IIC T3	A550	490	386	403	65	55	M20	140	110	18	16	69	59	250	206	924	1009	924
IE2-WE2R 250 M4 Ex nA IIC T3	A550	440	362	406	60	55	M20	140	110	18	16	64	59	250	177	912	997	912
IE2-WE2R 250 M6 Ex nA IIC T3	A550	440	362	406	60	55	M20	140	110	18	16	64	59	250	177	912	997	912
IE2-WE2R 250 M8 Ex nA IIC T3	A550	440	362	406	60	55	M20	140	110	18	16	64	59	250	177	912	997	912
IE2-WE1R 280 S2 Ex nA IIC T3	A550	490	386	403	65	65	M20	140	140	18	18	69	69	280	206	924	1009	924
IE2-WE1R 280 M2 Ex nA IIC T3	A550	490	386	403	65	65	M20	140	140	18	18	69	69	280	206	970	1055	970
IE2-WE1R 280 S4 Ex nA IIC T3	A550	490	386	403	75	65	M20	140	140	20	18	79.5	69	280	206	924	1009	924
IE2-WE1R 280 M4 Ex nA IIC T3	A550	490	386	403	75	65	M20	140	140	20	18	79.5	69	280	206	970	1055	970
IE2-WE1R 280 S6 Ex nA IIC T3	A550	490	386	403	75	65	M20	140	140	20	18	79.5	69	280	206	970	1055	970
IE2-WE1R 280 M6 Ex nA IIC T3	A550	550	416	433	75	65	M20	140	140	20	18	79.5	69	280	211	1105	1215	1105
IE2-WE1R 280 S8 Ex nA IIC T3	A550	490	386	403	75	65	M20	140	140	20	18	79.5	69	280	206	970	1055	970
IE2-WE1R 280 M8 Ex nA IIC T3	A550	550	416	433	75	65	M20	140	140	20	18	79.5	69	280	211	1105	1215	1105

¹⁾ Centre holes to DIN 332-DS ...

Type designation	LC	LC k1 (IM B5)	TB Type Ex e IIC Standard	AG x	LL z	TB Type Ex e IIC VIK	AG x	LL z	AH -	O -	LB	BI BI
IE2-WE1R 225 M2 Ex nA IIC T3	891	891	100 A	222	214	200 A-SB	335	270	200	M50 x 1.5	40	8L
IE2-WE1R 225 S4 Ex nA IIC T3	921	921	100 A	222	214	200 A-SB	335	270	200	M50 x 1.5	40	8L
IE2-WE1R 225 M4 Ex nA IIC T3	977	977	100 A	222	214	200 A-SB	335	270	200	M50 x 1.5	45	8L
IE2-WE1R 225 S8 Ex nA IIC T3	881	881	100 A	222	214	200 A-SB	335	270	200	M50 x 1.5	40	8L
IE2-WE1R 225 M6 Ex nA IIC T3	977	977	100 A	222	214	200 A-SB	335	270	200	M50 x 1.5	45	8L
IE2-WE1R 225 M8 Ex nA IIC T3	977	977	100 A	222	214	200 A-SB	335	270	200	M50 x 1.5	45	8L
IE2-WE2R 225 M4 Ex nA IIC T3	971	971	100 A	222	214	200 A-SB	335	270	200	M50 x 1.5	40	8L
IE2-WE2R 225 M6 Ex nA IIC T3	921	921	100 A	222	214	200 A-SB	335	270	200	M50 x 1.5	40	8L
IE2-WE2R 225 S8 Ex nA IIC T3	921	921	100 A	222	214	200 A-SB	335	270	200	M50 x 1.5	40	8L
IE2-WE2R 225 M8 Ex nA IIC T3	921	921	100 A	222	214	200 A-SB	335	270	200	M50 x 1.5	40	8L
IE2-WE1R 250 M2 Ex nA IIC T3	977	977	100 A	222	214	200 A-SB	335	270	200	M63 x 1.5	45	8L
IE2-WE1R 250 M4 Ex nA IIC T3	1042	1042	200 A	290	252	200 A-SB	335	270	200	M63 x 1.5	50	8L
IE2-WE1R 250 M6 Ex nA IIC T3	1042	1042	200 A	290	252	200 A-SB	335	270	200	M63 x 1.5	50	8L
IE2-WE2R 250 M4 Ex nA IIC T3	1112	1112	100 A	222	214	200 A-SB	335	270	200	M63 x 1.5	45	8L
IE2-WE2R 250 M6 Ex nA IIC T3	1112	1112	100 A	222	214	200 A-SB	335	270	200	M63 x 1.5	45	8L
IE2-WE2R 250 M8 Ex nA IIC T3	1112	1112	100 A	222	214	200 A-SB	335	270	200	M63 x 1.5	45	8L
IE2-WE1R 280 S2 Ex nA IIC T3	1072	1072	200 A	290	252	200 A-SB	335	270	200	M63 x 1.5	50	8L
IE2-WE1R 280 M2 Ex nA IIC T3	1118	1118	200 A	290	252	200 A-SB	335	270	200	M63 x 1.5	50	8L
IE2-WE1R 280 S4 Ex nA IIC T3	1072	1072	200 A	290	252	200 A-SB	335	270	200	M63 x 1.5	50	8L
IE2-WE1R 280 M4 Ex nA IIC T3	1118	1118	200 A	290	252	200 A-SB	335	270	200	M63 x 1.5	50	8L
IE2-WE1R 280 S6 Ex nA IIC T3	1118	1118	200 A	290	252	200 A-SB	335	270	200	M63 x 1.5	50	8L
IE2-WE1R 280 M6 Ex nA IIC T3	1243	1243	200 A	290	252	200 A-SB	335	270	200	M63 x 1.5	55	8L
IE2-WE1R 280 S8 Ex nA IIC T3	1118	1118	200 A	290	252	200 A-SB	335	270	200	M63 x 1.5	50	8L
IE2-WE1R 280 M8 Ex nA IIC T3	1243	1243	200 A	290	252	200 A-SB	335	270	200	M63 x 1.5	55	8L

Three-phase motors with squirrel-cage rotor for operation in Zone 2 according to EN 60079-15 (EN 60079-7)

Type of explosion protection „n“ (Increased safety „ec“) and and for operation in Zones 21 and 22 according to EN 60079-31, Type of explosion protection – Protection by enclosure „tb, tc“, High Efficiency IE2 (VIK Recommendation 1, Three-Phase Asynchronous Motors – Technical Requirements 03.2011)

with surface cooling, type of cooling IC 411
Size 315, 355

Type of construction IM B5 [IM 3001]
Type of construction IM V1 [IM 3011]
Flange dimensions, see page 10/6

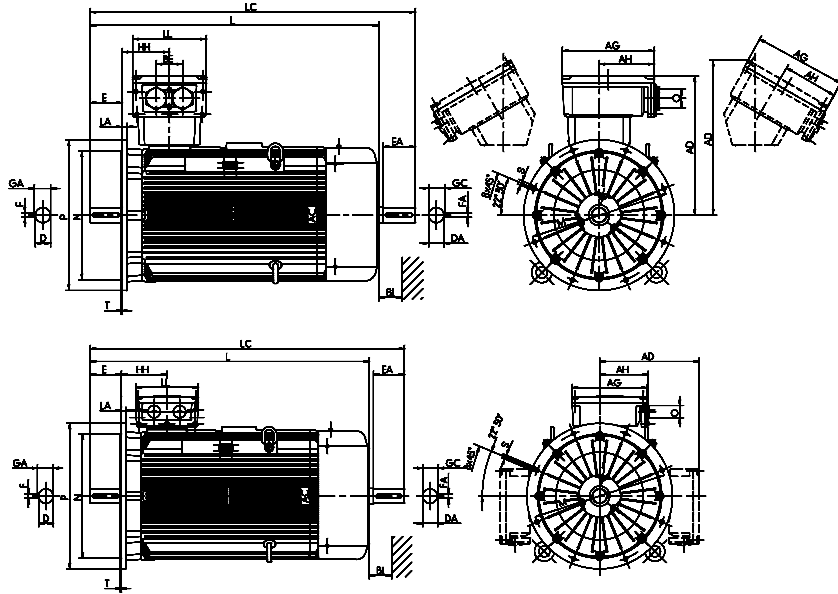

Type designation	Flange size	AC	AD	AD g1 (VIK)	D	DA	DB ¹⁾	E	EA	F	FA	GA	GC	H	HH	L
		g	g1		d	d1		l	l1	u	u1	t	t1	h	A	k
IE2-WE1R 315 S2 Ex nA IIC T3	A660	550	416	460.5	65	65	M20	140	140	18	18	69	69	315	211	1050
IE2-WE1R 315 M2 Ex nA IIC T3	A660	550	416	460.5	65	65	M20	140	140	18	18	69	69	315	211	1105
IE2-WE1R 315 MX2 Ex nA IIC T3	A660	550	416	460.5	65	65	M20	140	140	18	18	69	69	315	211	1185
IE2-WE1R 315 MY2 Ex nA IIC T3	A660	610	494	680.5	65	65	M20	140	140	18	18	69	69	315	230	1270
IE2-WE1R 315 L2 Ex nA IIC T3	A660	610	494	680.5	65	65	M20	140	140	18	18	69	69	315	230	1390
IE2-WE1R 315 LX2 Ex nA IIC T3	A660	610	494	680.5	65	65	M20	140	140	18	18	69	69	315	230	1510
IE2-WE1R 315 S4 Ex nA IIC T3	A660	550	416	460.5	80	70	M20	170	140	22	20	85	74.5	315	211	1080
IE2-WE1R 315 M4 Ex nA IIC T3	A660	550	416	460.5	80	70	M20	170	140	22	20	85	74.5	315	211	1135
IE2-WE1R 315 MX4 Ex nA IIC T3	A660	550	416	460.5	80	70	M20	170	140	22	20	85	74.5	315	211	1210
IE2-WE1R 315 MY4 Ex nA IIC T3	A660	610	494	680.5	80	70	M20	170	140	22	20	85	74.5	315	230	1300
IE2-WE1R 315 L4 Ex nA IIC T3	A660	610	494	680.5	80	70	M20	170	140	22	20	85	74.5	315	230	1420
IE2-WE1R 315 LX4 Ex nA IIC T3	A660	610	494	680.5	80	70	M20	170	140	22	20	85	74.5	315	230	1540
IE2-WE1R 315 S6 Ex nA IIC T3	A660	550	416	460.5	80	70	M20	170	140	22	20	85	74.5	315	211	1135
IE2-WE1R 315 M6 Ex nA IIC T3	A660	550	416	460.5	80	70	M20	170	140	22	20	85	74.5	315	211	1135
IE2-WE1R 315 MX6 Ex nA IIC T3	A660	610	494	680.5	80	70	M20	170	140	22	20	85	74.5	315	230	1300
IE2-WE1R 315 MY6 Ex nA IIC T3	A660	610	494	680.5	80	70	M20	170	140	22	20	85	74.5	315	230	1300
IE2-WE1R 315 L6 Ex nA IIC T3	A660	610	494	680.5	80	70	M20	170	140	22	20	85	74.5	315	230	1420
IE2-WE1R 315 LX6 Ex nA IIC T3	A660	610	494	680.5	80	70	M20	170	140	22	20	85	74.5	315	230	1420
IE2-WE1R 315 S8 Ex nA IIC T3	A660	550	416	460.5	80	70	M20	170	140	22	20	85	74.5	315	211	1135
IE2-WE1R 315 M8 Ex nA IIC T3	A660	550	416	460.5	80	70	M20	170	140	22	20	85	74.5	315	211	1135
IE2-WE1R 315 MX8 Ex nA IIC T3	A660	610	494	680.5	80	70	M20	170	140	22	20	85	74.5	315	230	1300
IE2-WE1R 315 MY8 Ex nA IIC T3	A660	610	494	680.5	80	70	M20	170	140	22	20	85	74.5	315	230	1300
IE2-WE1R 315 L8 Ex nA IIC T3	A660	610	494	680.5	80	70	M20	170	140	22	20	85	74.5	315	230	1420
IE2-WE1R 315 LX8 Ex nA IIC T3	A660	610	494	680.5	80	70	M20	170	140	22	20	85	74.5	315	230	1420
IE2-WE2R 355 MY2G Ex nA IIC T3	A800	715	736	736	80	80	M20	170	-	22	-	85	-	355	250	1530
IE2-WE2R 355 M2G Ex nA IIC T3	A800	715	736	736	80	80	M20	170	-	22	-	85	-	355	250	1530
IE2-WE2R 355 MY4 Ex nA IIC T3	A800	715	736	736	100	80	M24	210	170	28	22	106	85	355	250	1570
IE2-WE2R 355 M4 Ex nA IIC T3	A800	715	736	736	100	80	M24	210	170	28	22	106	85	355	250	1570
IE2-WE2R 355 MY6, 8 Ex nA IIC T3	A800	715	736	736	100	80	M24	210	170	28	22	106	85	355	250	1570
IE2-WE2R 355 M6 Ex nA IIC T3	A800	715	736	736	100	80	M24	210	170	28	22	106	85	355	250	1570
IE2-WE2R 355 MX6 Ex nA IIC T3	A800	715	736	736	100	80	M24	210	170	28	22	106	85	355	250	1690
IE2-WE2R 355 MY2G Ex nA IIC T3	A800	715	729	729	80	80	M20	170	-	22	-	85	-	355	327	1650
IE2-WE2R 355 L2G Ex nA IIC T3	A800	715	729	729	80	80	M20	170	-	22	-	85	-	355	327	1650
IE2-WE2R 355 MX4 Ex nA IIC T3	A800	715	729	729	100	80	M24	210	170	28	22	106	85	355	327	1690
IE2-WE2R 355 L4 Ex nA IIC T3	A800	715	729	729	100	80	M24	210	170	28	22	106	85	355	327	1690
IE2-WE2R 355 L8 Ex nA IIC T3	A800	715	729	729	100	80	M24	210	170	28	22	106	85	355	327	1690

¹⁾ Centre holes to DIN 332-DS ...

Type designation	L k (IM V1)	L k (IM B5)	LC k1	LC k1 (IM B5)	TB Type Ex e IIC Standard/VIK	AG x	LL z	AH -	O -	LB	BI BI
IE2-WE1R 315 S2 Ex nA IIC T3	1160	1050	1218	1218	400 A-SB	415	340	265	M63 x 1.5	55	8L
IE2-WE1R 315 M2 Ex nA IIC T3	1215	1105	1273	1273	400 A-SB	415	340	265	M63 x 1.5	55	8L
IE2-WE1R 315 MX2 Ex nA IIC T3	1295	1185	1353	1353	400 A-SB	415	340	265	M63 x 1.5	55	8L
IE2-WE1R 315 MY2 Ex nA IIC T3	1380	1270	1448	1448	630 A	496	390	301	M63 x 1.5	55	8L
IE2-WE1R 315 L2 Ex nA IIC T3	1500	1390	1568	1568	630 A	496	390	301	M63 x 1.5	55	8L
IE2-WE1R 315 LX2 Ex nA IIC T3	1620	1510	1688	1688	630 A	496	390	301	M63 x 1.5	55	8L
IE2-WE1R 315 S4 Ex nA IIC T3	1190	1080	1248	1248	400 A-SB	415	340	265	M63 x 1.5	55	8L
IE2-WE1R 315 M4 Ex nA IIC T3	1245	1135	1303	1303	400 A-SB	415	340	265	M63 x 1.5	55	8L
IE2-WE1R 315 MX4 Ex nA IIC T3	1325	1210	1383	1383	400 A-SB	415	340	265	M63 x 1.5	55	8L
IE2-WE1R 315 MY4 Ex nA IIC T3	1410	1300	1478	1478	630 A	496	390	301	M63 x 1.5	55	8L
IE2-WE1R 315 L4 Ex nA IIC T3	1530	1420	1598	1598	630 A	496	390	301	M63 x 1.5	55	8L
IE2-WE1R 315 LX4 Ex nA IIC T3	1650	1540	1718	1718	630 A	496	390	301	M63 x 1.5	55	8L
IE2-WE1R 315 S6 Ex nA IIC T3	1245	1135	1303	1303	400 A-SB	415	340	265	M63 x 1.5	55	8L
IE2-WE1R 315 M6 Ex nA IIC T3	1245	1135	1303	1303	400 A-SB	415	340	265	M63 x 1.5	55	8L
IE2-WE1R 315 MX6 Ex nA IIC T3	1410	1300	1478	1478	630 A	496	390	301	M63 x 1.5	55	8L
IE2-WE1R 315 MY6 Ex nA IIC T3	1410	1300	1478	1478	630 A	496	390	301	M63 x 1.5	55	8L
IE2-WE1R 315 L6 Ex nA IIC T3	1530	1420	1598	1598	630 A	496	390	301	M63 x 1.5	55	8L
IE2-WE1R 315 LX6 Ex nA IIC T3	1530	1420	1598	1598	630 A	496	390	301	M63 x 1.5	55	8L
IE2-WE1R 315 S8 Ex nA IIC T3	1245	1135	1303	1303	400 A-SB	415	340	265	M63 x 1.5	55	8L
IE2-WE1R 315 M8 Ex nA IIC T3	1245	1135	1303	1303	400 A-SB	415	340	265	M63 x 1.5	55	8L
IE2-WE1R 315 MX8 Ex nA IIC T3	1410	1300	1478	1478	630 A	496	390	301	M63 x 1.5	55	8L
IE2-WE1R 315 MY8 Ex nA IIC T3	1410	1300	1478	1478	630 A	496	390	301	M63 x 1.5	55	8L
IE2-WE1R 315 L8 Ex nA IIC T3	1530	1420	1598	1598	630 A	496	390	301	M63 x 1.5	55	8L
IE2-WE1R 315 LX8 Ex nA IIC T3	1530	1420	1598	1598	630 A	496	390	301	M63 x 1.5	55	8L
IE2-WE2R 355 MY2G Ex nA IIC T3	1650	1530	-	-	630 A	496	390	301	M75 x 1.5	60	8L
IE2-WE2R 355 M2G Ex nA IIC T3	1650	1530	-	-	630 A	496	390	301	M75 x 1.5	60	8L
IE2-WE2R 355 MY4 Ex nA IIC T3	1690	1570	1755	1755	630 A	496	390	301	M75 x 1.5	60	8L
IE2-WE2R 355 M4 Ex nA IIC T3	1690	1570	1755	1755	630 A	496	390	301	M75 x 1.5	60	8L
IE2-WE2R 355 MY6, 8 Ex nA IIC T3	1690	1570	1755	1755	630 A	496	390	301	M75 x 1.5	60	8L
IE2-WE2R 355 M6 Ex nA IIC T3	1690	1570	1755	1755	630 A	496	390	301	M75 x 1.5	60	8L
IE2-WE2R 355 MX6 Ex nA IIC T3	1810	1690	1875	1875	630 A	496	390	301	M75 x 1.5	60	8L
IE2-WE2R 355 MX2G Ex nA IIC T3	1770	1650	-	-	1000 A	615	474	385	M75 x 1.5	60	8L
IE2-WE2R 355 L2G Ex nA IIC T3	1770	1650	-	-	1000 A	615	474	385	M75 x 1.5	60	8L
IE2-WE2R 355 MX4 Ex nA IIC T3	1810	1690	1875	1875	1000 A	615	474	385	M75 x 1.5	60	8L
IE2-WE2R 355 L4 Ex nA IIC T3	1810	1690	1875	1875	1000 A	615	474	385	M75 x 1.5	60	8L
IE2-WE2R 355 L8 Ex nA IIC T3	1810	1690	1875	1875	1000 A	615	474	385	M75 x 1.5	60	8L

Three-phase motors with squirrel-cage rotor for operation in Zone 2 according to EN 60079-15 (EN 60079-7)

Type of explosion protection „n“ (Increased safety „ec“) and and for operation in Zones 21 and 22 according to EN 60079-31, Type of explosion protection – Protection by enclosure „tb, tc“, Standard Efficiency IE1 (VIK Recommendation 1, Three-Phase Asynchronous Motors – Technical Requirements 03.2011)

with surface cooling, type of cooling IC 411
Size 63 to 280

Type of construction IM B3 [IM 1001]

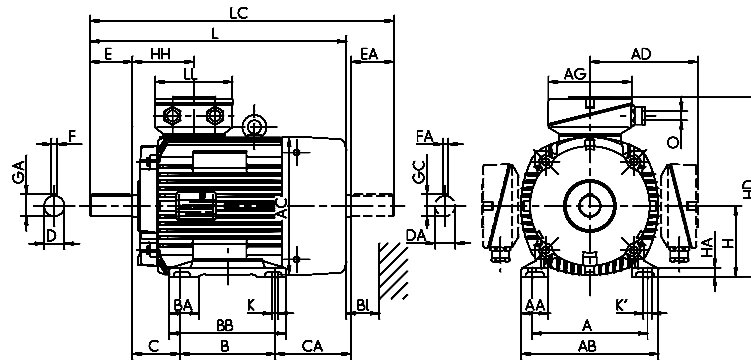

Type designation	Flange size	A	AA	AB	AC	AD	AD VIK	B	BA	BB	C	CA	D	DA	DB ¹⁾	E	EA	F	FA
		b	n	f	g	g1	g1	a	m	e	w1	w2	d	d1		l	l1	u	u1
K21R 63 K2, 4, 6	FF115	100	28	128	109	-	-	80	-	100	40	39	11	11	M4	23	23	4	4
K21R 63 G2, 4, 6	FF115	100	28	128	109	-	-	80	-	100	40	39	11	11	M4	23	23	4	4
K21R 71 K2, 4, 6, 8	FF130	112	32	138	124	-	-	90	-	116	45	43.5	14	14	M5	30	30	5	5
K21R 71 G2, 4, 6, 8	FF130	112	32	138	124	-	-	90	-	116	45	43.5	14	14	M5	30	30	5	5
(IE1-)K21R 80 K2, 4, 6, 8	FF 165	125	38	168	139	-	-	100	-	125	50	63	19	19	M6	40	40	6	6
(IE1-)K21R 80 G2, 4, 6, 8	FF 165	125	38	168	139	-	-	100	-	125	50	63	19	19	M6	40	40	6	6
(IE1-)K21R 90 S2, 4, 6, 8	FF 165	140	40	178	157	-	-	100	-	130	56	74	24	22	M8	50	50	8	6
(IE1-)K21R 90 L2, 4, 6, 8	FF 165	140	40	178	157	-	-	125	-	155	56	71	24	22	M8	50	50	8	6
(IE1-)K21R 100 L2, 4, 6, 8	FF 215	160	45	192	177	-	-	140	-	175	63	73	28	24	M10	60	50	8	8
(IE1-)K21R 100 LX4, 8	FF 215	160	32	188	196	-	-	140	-	171	63	102	28	28	M10	60	60	8	8
(IE1-)K21R 112 M2	FF 215	190	50	224	196	-	-	140	-	180	70	95	28	28	M10	60	60	8	8
(IE1-)K21R 112 M6, 8	FF 215	190	50	224	196	-	-	140	-	180	70	95	28	28	M10	60	60	8	8
(IE1-)K21R 112 MX2	FF 215	190	50	224	196	-	-	140	-	180	70	129	28	28	M10	60	60	8	8
(IE1-)K21R 112 M4	FF 215	190	50	224	196	-	-	140	-	180	70	129	28	28	M10	60	60	8	8
(IE1-)K..R(Q)132 S2	FF265	216	50	256	217	189	189	140	55	180	89	153	38	32	M12	80	80	10	10
(IE1-)K..R(Q)132 SX2	FF265	216	50	256	217	189	189	140	55	180	89	173	38	32	M12	80	80	10	10
(IE1-)K..R(Q)132 S4, 6, 8	FF265	216	50	256	217	189	189	140	55	180	89	153	38	32	M12	80	80	10	10
(IE1-)K..R(Q)132 M4	FF265	216	50	256	258	210	210	178	55	218	89	138	38	38	M12	80	80	10	10
(IE1-)K..R(Q)132 MX6	FF265	216	50	256	258	210	210	178	55	218	89	138	38	38	M12	80	80	10	10
(IE1-)K..R(Q)132 M6, 8	FF265	216	50	256	217	189	189	178	55	218	89	135	38	32	M12	80	80	10	10
(IE1-)K..R(Q)160 M2	FF300	254	55	296	258	210	210	210	60	257	108	135	42	38	M16	110	80	12	10
(IE1-)K..R(Q)160 M4, 6, 8	FF300	254	55	296	258	249	275	210	60	257	108	135	42	38	M16	110	80	12	10
(IE1-)K..R(Q)160 MX8	FF300	254	55	296	258	249	275	210	60	257	108	135	42	38	M16	110	80	12	10
(IE1-)K..R(Q)160 MX2	FF300	254	55	296	313	249	275	210	60	257	108	148	42	42	M16	110	110	12	12
(IE1-)K..R(Q)160 L2, 4, 6, 8	FF300	254	55	296	313	249	275	254	60	301	108	142	42	42	M16	110	110	12	12
(IE1-)K..R(Q)180 M2	FF300	279	62	328	351	268	294	241	65	288	121	169	48	48	M16	110	110	14	14
(IE1-)K..R(Q)180 M4	FF300	279	62	328	313	249	275	241	65	288	121	142	48	42	M16	110	110	14	12
(IE1-)K..R(Q)180 L4	FF300	279	62	328	351	268	294	279	65	326	121	176	48	48	M16	110	110	14	14
(IE1-)K..R(Q)180 L6, 8	FF300	279	62	328	313	249	275	279	65	326	121	104	48	42	M16	110	110	14	12
(IE1-)K..R(Q)200 L2, 4, 6, 8	FF 350	318	70	372	351	268	294	305	70	360	133	138	55	48	M20	110	110	16	14
(IE1-)K..R(Q)200 LX6	FF 350	318	70	372	351	268	294	305	70	360	133	138	55	48	M20	110	110	16	14
(IE1-)K..R(Q)200 LX2	FF 350	318	70	372	390	313	378	305	70	360	133	193	55	55	M20	110	110	16	16
(IE1-)K..R(Q)225 S4, 8	FF 400	356	75	413	390	313	378	286	75	343	149	196	60	55	M20	140	110	18	16
(IE1-)K..R(Q)225 M2	FF 400	356	75	413	390	313	378	311	75	368	149	211	55	55	M20	110	110	16	16
(IE1-)K..R(Q)225 M4	FF 400	356	75	413	390	313	378	311	75	368	149	211	60	55	M20	140	110	18	16
(IE1-)K..R(Q)225 M6, 8	FF 400	356	75	413	390	313	378	311	75	368	149	171	60	55	M20	140	110	18	16
(IE1-)K..R(Q)250 M2	FF 500	406	84	471	440	337	406	349	84	412	168	210	60	55	M20	140	110	18	16
(IE1-)K..R(Q)250 M4, 6, 8	FF 500	406	84	471	440	337	406	349	84	412	168	210	65	55	M20	140	110	18	16
(IE1-)K..R(Q)280 S2	FF 500	457	94	522	490	399	399	368	96	431	190	234	65	65	M20	140	140	18	18
(IE1-)K..R(Q)280 S4, 6, 8	FF 500	457	94	522	490	399	399	368	96	431	190	234	75	65	M20	140	140	20	18
(IE1-)K..R(Q)280 M2	FF 500	457	94	522	490	399	399	419	96	482	190	229	65	65	M20	140	140	18	18
(IE1-)K..R(Q)280 M4, 6, 8	FF 500	457	94	522	490	399	399	419	96	482	190	229	75	65	M20	140	140	20	18

¹⁾ Centre holes to DIN 332-DS ...

Three-phase motors with squirrel-cage rotor for operation in Zone 2 according to EN 60079-15 (EN 60079-7)

Type of explosion protection „n“ (Increased safety „ec“) and and for operation in Zones 21 and 22 according to EN 60079-31, Type of explosion protection – Protection by enclosure „tb, tc“, Standard Efficiency IE1 (VIK Recommendation 1, Three-Phase Asynchronous Motors – Technical Requirements 03.2011)

with surface cooling, type of cooling IC 411
Size 63 to 280

Type of construction IM B35 [IM 2001]

Flange dimensions, see page 10/6

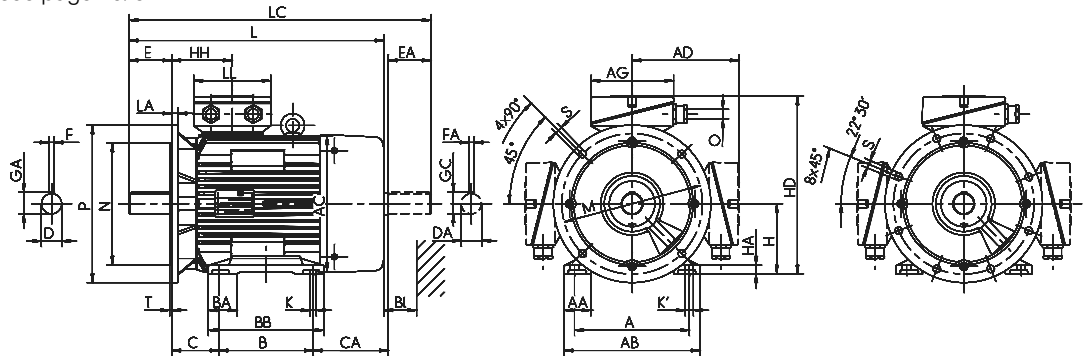

Type designation	GA	GC	H	HA	HD	HD**)	HD	HH	K	K'	L	LC	TB Type	AG	LL	O	TB Type	AG	LL	O	Hole pattern	BI
	t	tl	h	c	p	p	p	A	s	s'	k	k1	Ex e IIC Standard	Ex e IIC VIK	Ex e IIC VIK	Ex e IIC VIK	Ex e IIC VIK	Ex e IIC VIK	Ex e IIC VIK	Ex e IIC VIK	Ex e IIC VIK	Ex e IIC VIK
K21R 63 K2, 4, 6	12.5	12.5	63	10	180	***)	-	67	8	8	179	205	-	-	-	-	KA 05-13	104	112	M25 x 1.5	4L	14
K21R 63 G2, 4, 6	12.5	12.5	63	10	180	***)	-	67	8	8	179	205	-	-	-	-	KA 05-13	104	112	M25 x 1.5	4L	14
K21R 71 K2, 4, 6, 8	16	16	71	11	194	***)	-	70	8	8	206	239	-	-	-	-	KA 05-13	104	112	M25 x 1.5	4L	14
K21R 71 G2, 4, 6, 8	16	16	71	11	194	***)	-	70	8	8	206	239	-	-	-	-	KA 05-13	104	112	M25 x 1.5	4L	14
(IE1-)K21R 80 K2, 4, 6, 8	21.5	21.5	80	12	210	***)	-	76	10	10	249	293	-	-	-	-	KA 05-13	104	112	M25 x 1.5	4L	16
(IE1-)K21R 80 G2, 4, 6, 8	21.5	21.5	80	12	210	***)	-	76	10	10	249	293	-	-	-	-	KA 05-13	104	112	M25 x 1.5	4L	16
(IE1-)K21R 90 S2, 4, 6, 8	27	24.5	90	14	229	***)	-	79	10	10	275	330	-	-	-	-	KA 05-13	104	112	M25 x 1.5	4L	16
(IE1-)K21R 90 L2, 4, 6, 8	27	24.5	90	14	229	***)	-	79	10	10	297	352	-	-	-	-	KA 05-13	104	112	M25 x 1.5	4L	16
(IE1-)K21R 100 L2, 4, 6, 8	31	27	100	15	246	***)	-	84	12	12	331	386	-	-	-	-	KA 05-13	104	112	M25 x 1.5	4L	18
(IE1-)K21R 100 LX4, 8	31	31	100	11	256	***)	-	86	12	12	357	425	-	-	-	-	KA 05-13	104	112	M25 x 1.5	4L	20
(IE1-)K21R 112 M2	31	31	112	18	268	***)	-	86	12	12	357	425	-	-	-	-	KA 05-13	104	112	M25 x 1.5	4L	20
(IE1-)K21R 112 M6, 8	31	31	112	18	268	***)	-	86	12	12	357	425	-	-	-	-	KA 05-13	104	112	M25 x 1.5	4L	20
(IE1-)K21R 112 MX2	31	31	112	18	268	***)	-	86	12	12	391	459	-	-	-	-	KA 05-13	104	112	M25 x 1.5	4L	20
(IE1-)K21R 112 M4	31	31	112	18	268	***)	-	86	12	12	391	459	-	-	-	-	KA 05-13	104	112	M25 x 1.5	4L	20
(IE1-)K..R(Q)132 S2	41	35	132	16	310	256.5	310	108	12	12	459	542	25 A	143	134	M32 x 1.5	25 AV	143	134	M32 x 1.5	4L	35
(IE1-)K..R(Q)132 SX2	41	35	132	16	310	256.5	310	108	12	12	479	562	25 A	143	134	M32 x 1.5	25 AV	143	134	M32 x 1.5	4L	35
(IE1-)K..R(Q)132 S4, 6, 8	41	35	132	16	310	256.5	310	108	12	12	459	542	25 A	143	134	M32 x 1.5	25 AV	143	134	M32 x 1.5	4L	35
(IE1-)K..R(Q)132 M4	41	41	132	16	331	279	331	114	12	12	481	565	25 A	143	134	M32 x 1.5	25 AV	143	134	M32 x 1.5	4L	35
(IE1-)K..R(Q)132 MX6	41	41	132	16	331	279	331	114	12	12	481	565	25 A	143	134	M32 x 1.5	25 AV	143	134	M32 x 1.5	4L	35
(IE1-)K..R(Q)132 M6, 8	41	35	132	16	310	256.5	310	108	12	12	479	562	25 A	143	134	M32 x 1.5	25 AV	143	134	M32 x 1.5	4L	35
(IE1-)K..R(Q)160 M2	45	41	160	18	370	307	370	114	15	15	559	643	25 A	143	134	M32 x 1.5	25 AV	143	134	M32 x 1.5	4L	35
(IE1-)K..R(Q)160 M4, 6, 8	45	41	160	18	370	307	370	114	15	15	559	643	25 A	143	134	M32 x 1.6	25 AV	143	134	M32 x 1.6	4L	35
(IE1-)K..R(Q)160 MX8	45	41	160	18	409	336	435	138	15	15	559	643	63 A	184	172	M40 x 1.5	100/63 AV	223	214	M40 x 1.5	4L	35
(IE1-)K..R(Q)160 MX2	45	45	160	18	409	336	435	138	15	20	571	686	63 A	184	172	M40 x 1.5	100/63 AV	223	214	M40 x 1.5	4L	35
(IE1-)K..R(Q)160 L2, 4, 6, 8	45	45	160	18	409	336	435	138	15	20	609	724	63 A	184	172	M40 x 1.5	100/63 AV	223	214	M40 x 1.5	4L	35
(IE1-)K..R(Q)180 M2	51.5	51.5	180	20	450	369	476	147	15	20	635	751	63 A	184	172	M40 x 1.5	100/63 AV	223	214	M40 x 1.5	4L	35
(IE1-)K..R(Q)180 M4	51.5	45	180	20	433	356	459	138	15	20	609	724	63 A	184	172	M40 x 1.5	100/63 AV	223	214	M40 x 1.5	4L	35
(IE1-)K..R(Q)180 L4	51.5	51.5	180	20	450	369	476	147	15	20	680	796	63 A	184	172	M40 x 1.5	100/63 AV	223	214	M40 x 1.5	4L	35
(IE1-)K..R(Q)180 L6, 8	51.5	45	180	20	433	356	459	138	15	20	609	724	63 A	184	172	M40 x 1.5	100/63 AV	223	214	M40 x 1.5	4L	35
(IE1-)K..R(Q)200 L2, 4, 6, 8	59	51.5	200	22	472	389	498	147	19	25	680	796	63 A	184	172	M40 x 1.5	100/63 AV	223	214	M50 x 1.5	4L	35
(IE1-)K..R(Q)200 LX6	59	51.5	200	22	472	389	498	147	19	25	680	796	63 A	184	172	M40 x 1.5	100/63 AV	223	214	M50 x 1.5	4L	35
(IE1-)K..R(Q)200 LX2	59	59	200	22	515	417	579	168	19	25	727	851	100 A	222	214	M50 x 1.5	200 A-SB	335	270	M63 x 1.5	4L	35
(IE1-)K..R(Q)225 S4, 8	64	59	225	25	540	442	605	168	19	25	757	881	100 A	222	214	M50 x 1.5	200 A-SB	335	270	M63 x 1.5	8L	40
(IE1-)K..R(Q)225 M2	59	59	225	25	540	442	605	168	19	25	767	891	100 A	222	214	M50 x 1.5	200 A-SB	335	270	M63 x 1.5	8L	40
(IE1-)K..R(Q)225 M4	64	59	225	25	540	442	605	168	19	25	797	921	100 A	222	214	M50 x 1.5	200 A-SB	335	270	M63 x 1.5	8L	40
(IE1-)K..R(Q)225 M6, 8	64	59	225	25	540	442	605	168	19	25	757	881	100 A	222	214	M50 x 1.5	200 A-SB	335	270	M63 x 1.5	8L	40
(IE1-)K..R(Q)250 M2	64	59	250	28	589	484	656	177	24	30	862	977	100 A	222	214	M50 x 1.5	200 A-SB	335	270	M63 x 1.5	8L	45
(IE1-)K..R(Q)250 M4, 6, 8	69	59	250	28	589	484	656	177	24	30	862	977	100 A	222	214	M50 x 1.5	200 A-SB	335	270	M63 x 1.5	8L	45
(IE1-)K..R(Q)280 S2	69	69	280	32	677	537	677	206	24	30	924	1072	200 A	290	252	M63 x 1.5	200 A-SB	335	270	M63 x 1.5	8L	50
(IE1-)K..R(Q)280 S4, 6, 8	79.5	69	280	32	677	537	677	206	24	30	924	1072	200 A	290	252	M63 x 1.5	200 A-SB	335	270	M63 x 1.5	8L	50
(IE1-)K..R(Q)280 M2	69	69	280	32	677	537	677	206	24	30	970	1118	200 A	290	252	M63 x 1.5	200 A-SB	335	270	M63 x 1.5	8L	50
(IE1-)K..R(Q)280 M4, 6, 8	79.5	69	280	32	677	537	677	206	24	30	970	1118	200 A	290	252	M63 x 1.5	200 A-SB	335	270	M63 x 1.5	8L	50

** Terminal box left/right
***) upon request

Three-phase motors with squirrel-cage rotor for operation in Zone 2 according to EN 60079-15 (EN 60079-7)

Type of explosion protection „n“ (Increased safety „ec“) and and for operation in Zones 21 and 22 according to EN 60079-31, Type of explosion protection – Protection by enclosure „tb, tc“, Standard Efficiency IE1 (VIK Recommendation 1, Three-Phase Asynchronous Motors – Technical Requirements 03.2011)

with surface cooling, type of cooling IC 411
Size 315

Type of construction IM B3 [IM 1001]

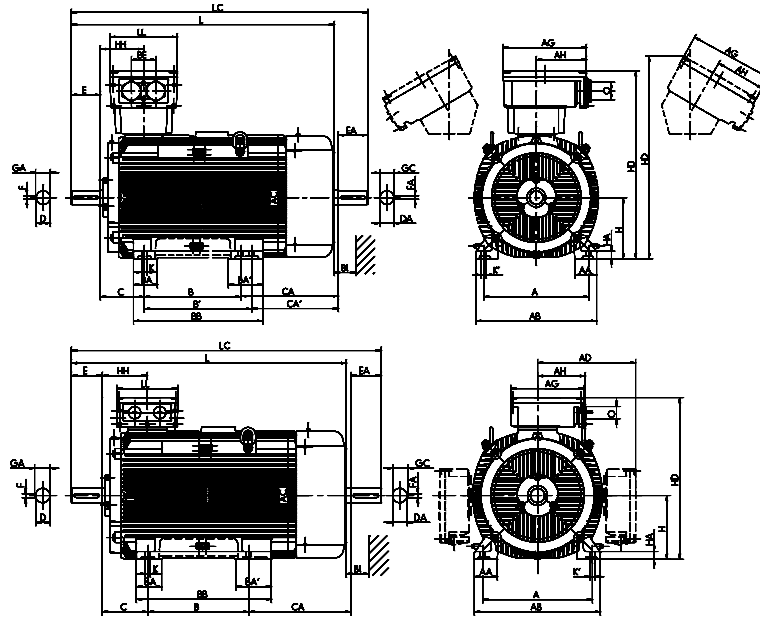

Type designation	Flange size	A	AA	AB	AC	AD	AD	B	BA	BA'	BB	C	CA	D	DA	DB ¹⁾	E	EA	F	FA
		b	n	f	g	g1	g1	a	m	m1	e	w1	w2	d	d1		l	l1	u	u1
(IE1-)K..R(Q)315 S2	FF 600	508	126	590	550	460	460	406	120	-	503	216	316	65	65	M20	140	140	18	18
(IE1-)K..R(Q)315 S4, 6, 8	FF 600	508	126	590	550	460	460	406	120	-	503	216	316	80	70	M20	170	140	22	20
(IE1-)K..R(Q)315 M2	FF 600	508	126	590	550	460	460	457	120	150	554	216	320	65	65	M20	140	140	18	18
(IE1-)K..R(Q)315 M4, 6, 8	FF 600	508	126	590	550	460	460	457	120	150	554	216	320	80	70	M20	170	140	22	20
(IE1-)K..R(Q)315 MX2	FF 600	508	126	590	550	460	460	457	120	150	554	216	400	65	65	M20	140	140	18	18
(IE1-)K..R(Q)315 MX4	FF 600	508	126	590	550	460	460	457	120	150	554	216	400	80	70	M20	170	140	22	20
(IE1-)K..R(Q)315 MX6, 8	FF 600	508	126	590	550	460	460	457	120	150	554	216	320	80	70	M20	170	140	22	20
(IE1-)K..R(Q)315 MX10, 12	FF 600	508	126	590	550	460	460	457	120	150	554	216	320	80	70	M20	170	140	22	20
(IE1-)K..R(Q)315 MY2	FF 600	508	110	590	610	681	681	457	120	-	573	216	495	65	65	M20	140	140	18	18
(IE1-)K..R(Q)315 MY4, 6, 8	FF 600	508	110	590	610	681	681	457	120	-	573	216	495	80	70	M20	170	140	22	20
(IE1-)K..R(Q)315 L2	FF 600	508	110	590	610	681	681	508	120	-	624	216	539	65	65	M20	140	140	18	18
(IE1-)K..R(Q)315 L4, 6, 8	FF 600	508	110	590	610	681	681	508	120	-	624	216	564	80	70	M20	170	140	22	20
(IE1-)K..R(Q)315 LX2	FF 600	508	110	590	610	681	681	508	120	-	624	216	684	65	65	M20	140	140	18	18
(IE1-)K..R(Q)315 LX4	FF 600	508	110	590	610	681	681	508	120	-	624	216	689	80	70	M20	170	140	22	20
(IE1-)K..R(Q)315 LX6, 8	FF 600	508	110	590	610	681	681	508	120	-	624	216	564	80	70	M20	170	140	22	20

¹⁾ Centre holes to DIN 332-DS ...

Three-phase motors with squirrel-cage rotor for operation in Zone 2 according to EN 60079-15 (EN 60079-7)

Type of explosion protection „n“ (Increased safety „ec“) and and for operation in Zones 21 and 22 according to EN 60079-31, Type of explosion protection – Protection by enclosure „tb, tc“, Standard Efficiency IE1 (VIK Recommendation 1, Three-Phase Asynchronous Motors – Technical Requirements 03.2011)

with surface cooling, type of cooling IC 411
Size 315

Type of construction IM B35 [IM 2001]

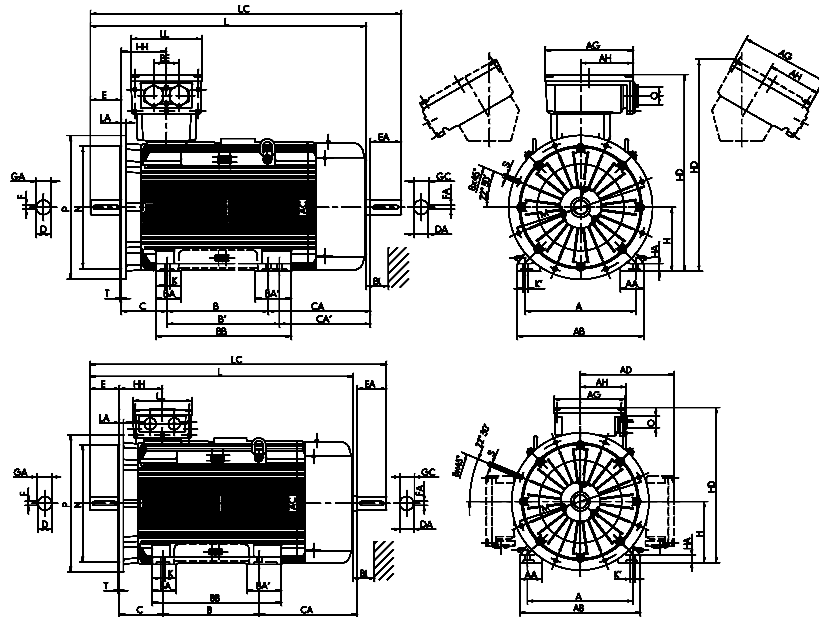

Type designation	GA	GC	H	HA	HD	HD ^{*)}	HD	HH	K	K'	L	LC	TB Type	AG	LL	AH	O	BI
	t	t1	h	c	p	p	p	A	s	s'	k	k1	Standard/VIK					BI
(IE1-)K..R(Q)315 S2	69	69	315	44	775	610	775	211	28	35	1050	1218	400 A-SB	415	340	265	M63 x 1.5	55
(IE1-)K..R(Q)315 S4, 6, 8	85	74.5	315	44	775	610	775	211	28	35	1080	1248	400 A-SB	415	340	265	M63 x 1.5	55
(IE1-)K..R(Q)315 M2	69	69	315	44	775	610	775	211	28	35	1105	1273	400 A-SB	415	340	265	M63 x 1.5	55
(IE1-)K..R(Q)315 M4, 6, 8	85	74.5	315	44	775	610	775	211	28	35	1135	1303	400 A-SB	415	340	265	M63 x 1.5	55
(IE1-)K..R(Q)315 MX2	69	69	315	44	775	610	775	211	28	35	1185	1353	400 A-SB	415	340	265	M63 x 1.5	55
(IE1-)K..R(Q)315 MX4	85	74.5	315	44	775	610	775	211	28	35	1210	1383	400 A-SB	415	340	265	M63 x 1.5	55
(IE1-)K..R(Q)315 MX6, 8	85	74.5	315	44	775	610	775	211	28	35	1135	1303	400 A-SB	415	340	265	M63 x 1.5	55
(IE1-)K..R(Q)315 MX10, 12	85	74.5	315	44	775	610	775	211	28	35	1135	1303	400 A-SB	415	340	265	M63 x 1.5	55
(IE1-)K..R(Q)315 MY2	69	69	315	44	996	628	996	230	28	35	1270	1448	630 A	496	390	301	M63 x 1.5	55
(IE1-)K..R(Q)315 MY4, 6, 8	85	74.5	315	44	996	628	996	230	28	35	1300	1478	630 A	496	390	301	M63 x 1.5	55
(IE1-)K..R(Q)315 L2	69	69	315	44	996	628	996	230	28	35	1390	1543	630 A	496	390	301	M63 x 1.5	55
(IE1-)K..R(Q)315 L4, 6, 8	85	74.5	315	44	996	628	996	230	28	35	1420	1598	630 A	496	390	301	M63 x 1.5	55
(IE1-)K..R(Q)315 LX2	69	69	315	44	996	628	996	230	28	35	1510	1688	630 A	496	390	301	M63 x 1.5	55
(IE1-)K..R(Q)315 LX4	85	74.5	315	44	996	628	996	230	28	35	1540	1723	630 A	496	390	301	M63 x 1.5	55
(IE1-)K..R(Q)315 LX6, 8	85	74.5	315	44	996	628	996	230	28	35	1420	1598	630 A	496	390	301	M63 x 1.5	55

^{*)} Terminal box left/right

Three-phase motors with squirrel-cage rotor for operation in Zone 2 according to EN 60079-15 (EN 60079-7)

Type of explosion protection „n“ (Increased safety „ec“) and and for operation in Zones 21 and 22 according to EN 60079-31, Type of explosion protection – Protection by enclosure „tb, tc“, Standard Efficiency IE1 (VIK Recommendation 1, Three-Phase Asynchronous Motors – Technical Requirements 03.2011)

with surface cooling, type of cooling IC 411
Size 63 to 180

Type of construction IM B34 [IM 2101]
Flange dimensions, see page 10/6

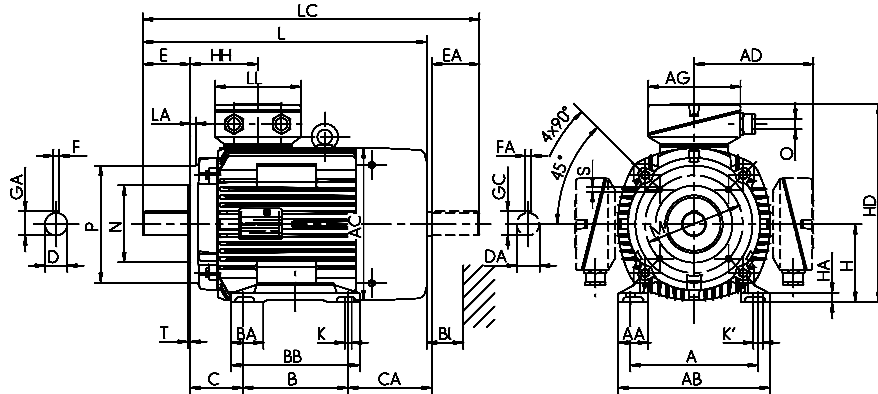

Type designation	Flange size		A	AA	AB	AC	AD	AD	B	BA	BB	C	CA	D	DA	DB ¹⁾	E	EA	F	FA
	small	large	b	n	f	g	g1	VIK g1	a	m	e	w1	w2	d	d1		l	l1	u	u1
K21R 63 K2, 4, 6	FT 75	FT 100	100	28	128	109	-	-	80	-	100	40	39	11	11	M4	23	23	4	4
K21R 63 G2, 4, 6	FT 75	FT 100	100	28	128	109	-	-	80	-	100	40	39	11	11	M4	23	23	4	4
K21R 71 K2, 4, 6, 8	FT 85	FT 115	112	32	138	124	-	-	90	-	116	45	43.5	14	14	M5	30	30	5	5
K21R 71 G2, 4, 6, 8	FT 85	FT 115	112	32	138	124	-	-	90	-	116	45	43.5	14	14	M5	30	30	5	5
(IE1-)K21R 80 K2, 4, 6, 8	FT 100	FT 130	125	38	168	139	-	-	100	-	125	50	63	19	19	M6	40	40	6	6
(IE1-)K21R 80 G2, 4, 6, 8	FT 100	FT 130	125	38	168	139	-	-	100	-	125	50	63	19	19	M6	40	40	6	6
(IE1-)K21R 90 S2, 4, 6, 8	FT 115	FT 130	140	40	178	157	-	-	100	-	130	56	74	24	22	M8	50	50	8	6
(IE1-)K21R 90 L2, 4, 6, 8	FT 115	FT 130	140	40	178	157	-	-	125	-	155	56	71	24	22	M8	50	50	8	6
(IE1-)K21R 100 L2, 4, 6, 8	FT 130	FT 165	160	45	192	177	-	-	140	-	175	63	73	28	24	M10	60	50	8	8
(IE1-)K21R 100 LX4, 8	FT 130	FT 165	160	32	188	196	-	-	140	-	171	63	102	28	28	M10	60	60	8	8
(IE1-)K21R 112 M2	FT 130	FT 165	190	50	224	196	-	-	140	-	180	70	95	28	28	M10	60	60	8	8
(IE1-)K21R 112 M6, 8	FT 130	FT 165	190	50	224	196	-	-	140	-	180	70	95	28	28	M10	60	60	8	8
(IE1-)K21R 112 MX2	FT 130	FT 165	190	50	224	196	-	-	140	-	180	70	129	28	28	M10	60	60	8	8
(IE1-)K21R 112 M4	FT 130	FT 165	190	50	224	196	-	-	140	-	180	70	129	28	28	M10	60	60	8	8
(IE1-)K..R(Q)132 S2	FT 130	FT 165	216	50	256	217	189	189	140	55	180	89	153	38	32	M12	80	80	10	10
(IE1-)K..R(Q)132 SX2	FT 130	FT 165	216	50	256	217	189	189	140	55	180	89	173	38	32	M12	80	80	10	10
(IE1-)K..R(Q)132 S4, 6, 8	FT 130	FT 165	216	50	256	217	189	189	140	55	180	89	153	38	32	M12	80	80	10	10
(IE1-)K..R(Q)132 M4	FT 165	FT 215	216	50	256	258	210	210	178	55	218	89	138	38	38	M12	80	80	10	10
(IE1-)K..R(Q)132 MX6	FT 165	FT 215	216	50	256	258	210	210	178	55	218	89	138	38	38	M12	80	80	10	10
(IE1-)K..R(Q)132 M6, 8	FT 130	FT 165	216	50	256	217	189	189	178	55	218	89	135	38	32	M12	80	80	10	10
(IE1-)K..R(Q)160 M2	FT 165	FT 215	254	55	296	258	210	210	210	60	257	108	135	42	38	M16	110	80	12	10
(IE1-)K..R(Q)160 M4, 6, 8	FT 165	FT 215	254	55	296	258	249	275	210	60	257	108	135	42	38	M16	110	80	12	10
(IE1-)K..R(Q)160 MX8	FT 165	FT 215	254	55	296	258	249	275	210	60	257	108	135	42	38	M16	110	80	12	10
(IE1-)K..R(Q)160 MX2	FT 215	FT 265	254	55	296	313	249	275	210	60	257	108	148	42	42	M16	110	110	12	12
(IE1-)K..R(Q)160 L2, 4, 6, 8	FT 215	FT 265	254	55	296	313	249	275	254	60	301	108	142	42	42	M16	110	110	12	12
(IE1-)K..R(Q)180 M4	FT 265	-	279	62	328	249	249	275	241	65	288	121	142	48	42	M16	110	110	14	12
(IE1-)K..R(Q)180 L6, 8	FT 265	-	279	62	328	249	275	275	279	65	326	121	104	48	42	M16	110	110	14	12

¹⁾ Centre holes to DIN 332-DS ...

Three-phase motors with squirrel-cage rotor for operation in Zone 2 according to EN 60079-15 (EN 60079-7)

Type of explosion protection „n“ (Increased safety „ec“) and and for operation in Zones 21 and 22 according to EN 60079-31, Type of explosion protection – Protection by enclosure „tb, tc“, Standard Efficiency IE1 (VIK Recommendation 1, Three-Phase Asynchronous Motors – Technical Requirements 03.2011)

with surface cooling, type of cooling IC 411
Size 63 to 180

Type of construction IM B14 [IM 3601]

Flange dimensions, see page 10/6

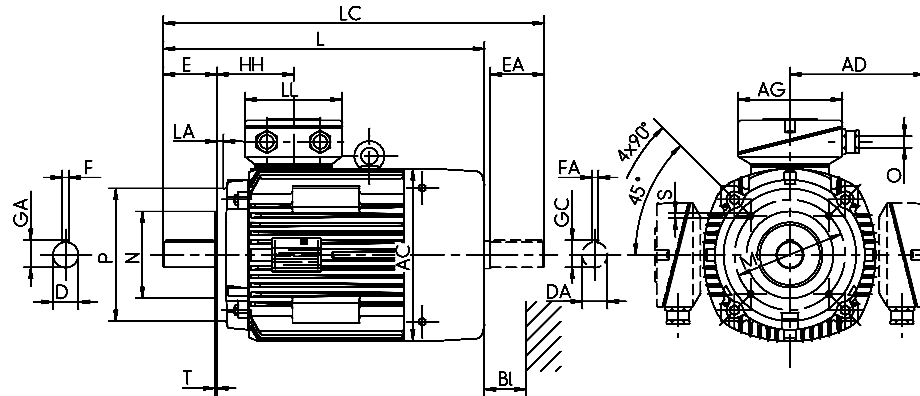

Type designation	GA	GC	H	HA	HD	HD**)	HD	HH	K	K'	L	LC	TB Type	AG	LL	O	TB Type	AG	LL	O	Hole pattern	BI
	t	t1	h	c	p	p	p	A	s	s'	k	k1	Ex e IIC Standard	Ex e IIC VIK			Ex e IIC VIK					
K21R 63 K2, 4, 6	12.5	12.5	63	10	180	***)	-	67	8	8	179	205	-	-	-	-	VIK16_M25	104	112	M25 x 1.5	4L	14
K21R 63 G2, 4, 6	12.5	12.5	63	10	180	***)	-	67	8	8	179	205	-	-	-	-	VIK16_M25	104	112	M25 x 1.5	4L	14
K21R 71 K2, 4, 6, 8	16	16	71	11	194	***)	-	70	8	8	206	239	-	-	-	-	VIK16_M25	104	112	M25 x 1.5	4L	14
K21R 71 G2, 4, 6, 8	16	16	71	11	194	***)	-	70	8	8	206	239	-	-	-	-	VIK16_M25	104	112	M25 x 1.5	4L	14
(IE1-)K21R 80 K2, 4, 6, 8	21.5	21.5	80	12	210	***)	-	76	10	10	249	293	-	-	-	-	VIK16_M25	104	112	M25 x 1.5	4L	16
(IE1-)K21R 80 G2, 4, 6, 8	21.5	21.5	80	12	210	***)	-	76	10	10	249	293	-	-	-	-	VIK16_M25	104	112	M25 x 1.5	4L	16
(IE1-)K21R 90 S2, 4, 6, 8	27	24.5	90	14	229	***)	-	79	10	10	275	330	-	-	-	-	VIK16_M25	104	112	M25 x 1.5	4L	16
(IE1-)K21R 90 L2, 4, 6, 8	27	24.5	90	14	229	***)	-	79	10	10	297	352	-	-	-	-	VIK16_M25	104	112	M25 x 1.5	4L	16
(IE1-)K21R 100 L2, 4, 6, 8	31	27	100	15	246	***)	-	84	12	12	331	386	-	-	-	-	VIK16_M25	104	112	M25 x 1.5	4L	18
(IE1-)K21R 100 LX4, 8	31	31	100	11	256	***)	-	86	12	12	357	425	-	-	-	-	VIK16_M25	104	112	M25 x 1.5	4L	20
(IE1-)K21R 112 M2	31	31	112	18	268	***)	-	86	12	12	357	425	-	-	-	-	VIK16_M25	104	112	M25 x 1.5	4L	20
(IE1-)K21R 112 M6, 8	31	31	112	18	268	***)	-	86	12	12	357	425	-	-	-	-	VIK16_M25	104	112	M25 x 1.5	4L	20
(IE1-)K21R 112 MX2	31	31	112	18	268	***)	-	86	12	12	391	459	-	-	-	-	VIK16_M25	104	112	M25 x 1.5	4L	20
(IE1-)K21R 112 M4	31	31	112	18	268	***)	-	86	12	12	391	459	-	-	-	-	VIK16_M25	104	112	M25 x 1.5	4L	20
(IE1-)K..R(Q)132 S2	41	35	132	16	310	***)	310	108	12	12	459	542	25 A	143	134	M32 x 1.5	25 AV	143	134	M32 x 1.5	4L	35
(IE1-)K..R(Q)132 SX2	41	35	132	16	310	***)	310	108	12	12	479	562	25 A	143	134	M32 x 1.5	25 AV	143	134	M32 x 1.5	4L	35
(IE1-)K..R(Q)132 S4, 6, 8	41	35	132	16	310	***)	310	108	12	12	459	542	25 A	143	134	M32 x 1.5	25 AV	143	134	M32 x 1.5	4L	35
(IE1-)K..R(Q)132 M4	41	41	132	16	331	***)	331	114	12	12	481	565	25 A	143	134	M32 x 1.5	25 AV	143	134	M32 x 1.5	4L	35
(IE1-)K..R(Q)132 MX6	41	41	132	16	331	***)	331	114	12	12	481	565	25 A	143	134	M32 x 1.5	25 AV	143	134	M32 x 1.5	4L	35
(IE1-)K..R(Q)132 M6, 8	41	35	132	16	310	***)	310	108	12	12	479	562	25 A	143	134	M32 x 1.5	25 AV	143	134	M32 x 1.5	4L	35
(IE1-)K..R(Q)160 M2	45	41	160	18	397	***)	370	114	15	15	559	643	25 A	143	134	M32 x 1.5	25 AV	143	134	M32 x 1.5	4L	35
(IE1-)K..R(Q)160 M4, 6, 8	45	41	160	18	397	***)	370	114	15	15	559	643	25 A	143	134	M32 x 1.5	25 AV	143	134	M32 x 1.5	4L	35
(IE1-)K..R(Q)160 MX8	45	41	160	18	397	***)	435	138	15	15	559	643	63 A	184	172	M40 x 1.5	100/63 AV	223	214	M40 x 1.5	4L	35
(IE1-)K..R(Q)160 MX2	45	45	160	18	402	***)	435	138	15	20	571	686	63 A	184	172	M40 x 1.5	100/63 AV	223	214	M40 x 1.5	4L	35
(IE1-)K..R(Q)160 L2, 4, 6, 8	45	45	160	18	402	***)	435	138	15	20	609	724	63 A	184	172	M40 x 1.5	100/63 AV	223	214	M40 x 1.5	4L	35
(IE1-)K..R(Q)180 M4	51.5	45	180	20	422	***)	459	138	15	20	609	724	63 A	184	172	M40 x 1.5	100/63 AV	223	214	M40 x 1.5	4L	35
(IE1-)K..R(Q)180 L6, 8	51.5	45	180	20	422	***)	459	138	15	20	609	724	63 A	184	172	M40 x 1.5	100/63 AV	223	214	M40 x 1.5	4L	35

** Terminal box left/right

*** upon request

Three-phase motors with squirrel-cage rotor for operation in Zone 2 according to EN 60079-15 (EN 60079-7)

Type of explosion protection „n“ (Increased safety „ec“) and and for operation in Zones 21 and 22 according to EN 60079-31, Type of explosion protection – Protection by enclosure „tb, tc“, Standard Efficiency IE1 (VIK Recommendation 1, Three-Phase Asynchronous Motors – Technical Requirements 03.2011)

with surface cooling, type of cooling IC 411
Size 63 to 280

Type of construction IM B5 [IM 3001]
Type of construction IM V1 [IM 3011]

Flange dimensions, see page 10/6

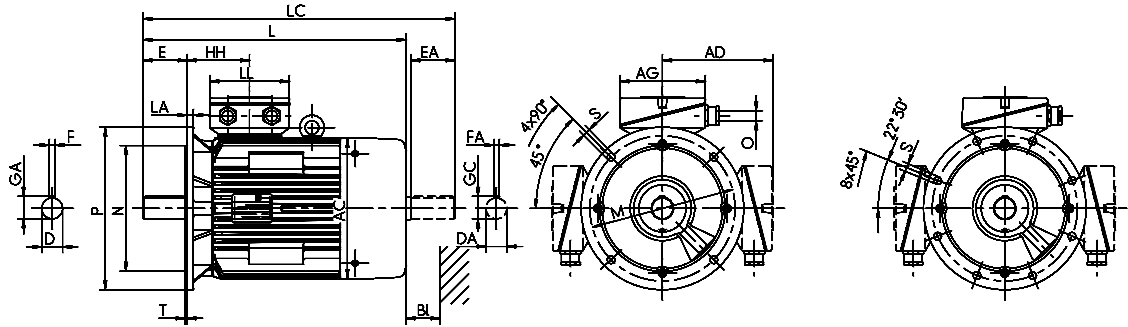

Type designation	Flange size	AC g	AD g1	D g1 (VIK)	DA d	DB ¹⁾ d1	E l	EA l1	F u	FA u1	GA t	GC t1	H h	HH A	
K21R 63 K2, 4, 6	FF115	109	-	-	11	11	M4	23	23	4	4	12.5	12.5	63	67
K21R 63 G2, 4, 6	FF115	109	-	-	11	11	M4	23	23	4	4	12.5	12.5	63	67
K21R 71 K2, 4, 6, 8	FF130	124	-	-	14	14	M5	30	30	5	5	16	16	71	70
K21R 71 G2, 4, 6, 8	FF130	124	-	-	14	14	M5	30	30	5	5	16	16	71	70
(IE1-)K21R 80 K2, 4, 6, 8	FF 165	139	-	-	19	19	M6	40	40	6	6	21.5	21.5	80	76
(IE1-)K21R 80 G2, 4, 6, 8	FF 165	139	-	-	19	19	M6	40	40	6	6	21.5	21.5	80	76
(IE1-)K21R 90 S2, 4, 6, 8	FF 165	157	-	-	24	22	M8	50	50	8	6	27	24.5	90	79
(IE1-)K21R 90 L2, 4, 6, 8	FF 165	157	-	-	24	22	M8	50	50	8	6	27	24.5	90	79
(IE1-)K21R 100 L2, 4, 6, 8	FF 215	177	-	-	28	24	M10	60	50	8	8	31	27	100	84
(IE1-)K21R 100 LX4, 8	FF 215	196	-	-	28	28	M10	60	60	8	8	31	31	100	86
(IE1-)K21R 112 M2	FF 215	196	-	-	28	28	M10	60	60	8	8	31	31	112	86
(IE1-)K21R 112 M6, 8	FF 215	196	-	-	28	28	M10	60	60	8	8	31	31	112	86
(IE1-)K21R 112 MX2	FF 215	196	-	-	28	28	M10	60	60	8	8	31	31	112	86
(IE1-)K21R 112 M4	FF 215	196	-	-	28	28	M10	60	60	8	8	31	31	112	86
(IE1-)K..R(Q)132 S2	FF265	217	189	189	38	32	M12	80	80	10	10	41	35	132	108
(IE1-)K..R(Q)132 SX2	FF265	217	189	189	38	32	M12	80	80	10	10	41	35	132	108
(IE1-)K..R(Q)132 S4, 6, 8	FF265	217	189	189	38	32	M12	80	80	10	10	41	35	132	108
(IE1-)K..R(Q)132 M4	FF265	258	210	210	38	38	M12	80	80	10	10	41	41	132	114
(IE1-)K..R(Q)132 MX6	FF265	258	210	210	38	38	M12	80	80	10	10	41	41	132	114
(IE1-)K..R(Q)132 M6, 8	FF265	217	189	189	38	32	M12	80	80	10	10	41	35	132	108
(IE1-)K..R(Q)160 M2	FF300	258	210	210	42	38	M16	110	80	12	10	45	41	160	114
(IE1-)K..R(Q)160 M4, 6, 8	FF300	258	249	275	42	38	M16	110	80	12	10	45	41	160	114
(IE1-)K..R(Q)160 MX8	FF300	313	249	275	42	38	M16	110	80	12	10	45	41	160	138
(IE1-)K..R(Q)160 MX2	FF300	313	249	275	42	42	M16	110	110	12	12	45	45	160	138
(IE1-)K..R(Q)160 L2, 4, 6, 8	FF300	313	249	275	42	42	M16	110	110	12	12	45	45	160	138
(IE1-)K..R(Q)180 M2	FF300	351	268	294	48	48	M16	110	110	14	14	51.5	51.5	180	147
(IE1-)K..R(Q)180 M4	FF300	313	249	275	48	42	M16	110	110	14	12	51.5	45	180	138
(IE1-)K..R(Q)180 L4	FF300	351	268	294	48	48	M16	110	110	14	14	51.5	51.5	180	147
(IE1-)K..R(Q)180 L6, 8	FF300	313	249	275	48	42	M16	110	110	14	12	51.5	45	180	138
(IE1-)K..R(Q)200 L2, 4, 6, 8	FF 350	351	268	294	55	48	M20	110	110	16	14	59	51.5	200	147
(IE1-)K..R(Q)200 LX6	FF 350	351	268	294	55	48	M20	110	110	16	14	59	51.5	200	147
(IE1-)K..R(Q)200 LX2	FF 350	390	313	378	55	55	M20	110	110	16	16	59	59	200	168
(IE1-)K..R(Q)225 S4, 8	FF 400	390	313	378	60	55	M20	140	110	18	16	64	59	225	168
(IE1-)K..R(Q)225 M2	FF 400	390	313	378	55	55	M20	110	110	16	16	59	59	225	168
(IE1-)K..R(Q)225 M4	FF 400	390	313	378	60	55	M20	140	110	18	16	64	59	225	168
(IE1-)K..R(Q)225 M6, 8	FF 400	390	313	378	60	55	M20	140	110	18	16	64	59	225	168
(IE1-)K..R(Q)250 M2	FF 500	440	337	406	60	55	M20	140	110	18	16	64	59	250	177
(IE1-)K..R(Q)250 M4, 6, 8	FF 500	440	337	406	65	55	M20	140	110	18	16	69	59	250	177
(IE1-)K..R(Q)280 S2	FF 500	490	399	399	65	65	M20	140	140	18	18	69	69	280	206
(IE1-)K..R(Q)280 S4, 6, 8	FF 500	490	399	399	75	65	M20	140	140	20	18	79.5	69	280	206
(IE1-)K..R(Q)280 M2	FF 500	490	399	399	65	65	M20	140	140	18	18	69	69	280	206
(IE1-)K..R(Q)280 M4, 6, 8	FF 500	490	399	399	75	65	M20	140	140	20	18	79.5	69	280	206

¹⁾ Centre holes to DIN 332-DS ...

Type designation	L	LC	TB Type	AG	LL	O	TB Type	AG	LL	O	Loch-	BI
	k	k1	Ex e IIC Standard	-	-	-	Ex e IIC VIK	-	-	-	bild	BI
K21R 63 K2, 4, 6	179	205	-	-	-	-	VIK16_M25	104	112	M25 x 1.5	4L	14
K21R 63 G2, 4, 6	179	205	-	-	-	-	VIK16_M25	104	112	M25 x 1.5	4L	14
K21R 71 K2, 4, 6, 8	206	239	-	-	-	-	VIK16_M25	104	112	M25 x 1.5	4L	14
K21R 71 G2, 4, 6, 8	206	239	-	-	-	-	VIK16_M25	104	112	M25 x 1.5	4L	14
(IE1-)K21R 80 K2, 4, 6, 8	249	293	-	-	-	-	VIK16_M25	104	112	M25 x 1.5	4L	16
(IE1-)K21R 80 G2, 4, 6, 8	249	293	-	-	-	-	VIK16_M25	104	112	M25 x 1.5	4L	16
(IE1-)K21R 90 S2, 4, 6, 8	275	330	-	-	-	-	VIK16_M25	104	112	M25 x 1.5	4L	16
(IE1-)K21R 90 L2, 4, 6, 8	297	352	-	-	-	-	VIK16_M25	104	112	M25 x 1.5	4L	16
(IE1-)K21R 100 L2, 4, 6, 8	331	386	-	-	-	-	VIK16_M25	104	112	M25 x 1.5	4L	18
(IE1-)K21R 100 LX4, 8	357	425	-	-	-	-	VIK16_M25	104	112	M25 x 1.5	4L	20
(IE1-)K21R 112 M2	357	425	-	-	-	-	VIK16_M25	104	112	M25 x 1.5	4L	20
(IE1-)K21R 112 M6, 8	391	425	-	-	-	-	VIK16_M25	104	112	M25 x 1.5	4L	20
(IE1-)K21R 112 MX2	391	459	-	-	-	-	VIK16_M25	104	112	M25 x 1.5	4L	20
(IE1-)K21R 112 M4	391	459	-	-	-	-	VIK16_M25	104	112	M25 x 1.5	4L	20
(IE1-)K..R(Q)132 S2	459	542	25 A	143	134	M32 x 1.5	25 AV	143	134	M32 x 1.5	4L	35
(IE1-)K..R(Q)132 SX2	479	562	25 A	143	134	M32 x 1.5	25 AV	143	134	M32 x 1.5	4L	35
(IE1-)K..R(Q)132 S4, 6, 8	459	542	25 A	143	134	M32 x 1.5	25 AV	143	134	M32 x 1.5	4L	35
(IE1-)K..R(Q)132 M4	481	565	25 A	143	134	M32 x 1.5	25 AV	143	134	M32 x 1.5	4L	35
(IE1-)K..R(Q)132 MX6	481	565	25 A	143	134	M32 x 1.5	25 AV	143	134	M32 x 1.5	4L	35
(IE1-)K..R(Q)132 M6, 8	479	562	25 A	143	134	M32 x 1.5	25 AV	143	134	M32 x 1.5	4L	35
(IE1-)K..R(Q)160 M2	559	643	25 A	143	134	M32 x 1.5	25 AV	143	134	M32 x 1.5	4L	35
(IE1-)K..R(Q)160 M4, 6, 8	559	643	25 A	143	134	M32 x 1.6	25 AV	143	134	M32 x 1.5	4L	35
(IE1-)K..R(Q)160 MX8	559	643	63 A	184	172	M40 x 1.5	100/63 AV	223	214	M40 x 1.5	4L	35
(IE1-)K..R(Q)160 MX2	571	686	63 A	184	172	M40 x 1.5	100/63 AV	223	214	M40 x 1.5	4L	35
(IE1-)K..R(Q)160 L2, 4, 6, 8	609	724	63 A	184	172	M40 x 1.5	100/63 AV	223	214	M40 x 1.5	4L	35
(IE1-)K..R(Q)180 M2	635	751	63 A	184	172	M40 x 1.5	100/63 AV	223	214	M40 x 1.5	4L	35
(IE1-)K..R(Q)180 M4	609	724	63 A	184	172	M40 x 1.5	100/63 AV	223	214	M40 x 1.5	4L	35
(IE1-)K..R(Q)180 L4	680	796	63 A	184	172	M40 x 1.5	100/63 AV	223	214	M40 x 1.5	4L	35
(IE1-)K..R(Q)180 L6, 8	609	724	63 A	184	172	M40 x 1.5	100/63 AV	223	214	M40 x 1.5	4L	35
(IE1-)K..R(Q)200 L2, 4, 6, 8	680	796	63 A	184	172	M50 x 1.5	100/63 AV	223	214	M50 x 1.5	4L	35
(IE1-)K..R(Q)200 LX6	680	796	63 A	184	172	M50 x 1.5	100/63 AV	223	214	M50 x 1.5	4L	35
(IE1-)K..R(Q)200 LX2	727	851	100 A	222	214	M50 x 1.5	200 A-SB	335	270	M50 x 1.5	4L	35
(IE1-)K..R(Q)225 S4, 8	757	881	100 A	222	214	M50 x 1.5	200 A-SB	335	270	M63 x 1.5	8L	40
(IE1-)K..R(Q)225 M2	767	891	100 A	222	214	M50 x 1.5	200 A-SB	335	270	M63 x 1.5	8L	40
(IE1-)K..R(Q)225 M4	797	921	100 A	222	214	M50 x 1.5	200 A-SB	335	270	M63 x 1.5	8L	40
(IE1-)K..R(Q)225 M6, 8	757	881	100 A	222	214	M50 x 1.5	200 A-SB	335	270	M63 x 1.5	8L	40
(IE1-)K..R(Q)250 M2	862	977	100 A	222	214	M50 x 1.5	200 A-SB	415	340	M63 x 1.5	8L	45
(IE1-)K..R(Q)250 M4, 6, 8	862	977	100 A	222	214	M50 x 1.5	200 A-SB	415	340	M63 x 1.5	8L	45
(IE1-)K..R(Q)280 S2	924	1072	200 A	290	252	M63 x 1.5	200 A-SB	415	340	M63 x 1.5	8L	50
(IE1-)K..R(Q)280 S4, 6, 8	924	1072	200 A	290	252	M63 x 1.5	200 A-SB	415	340	M63 x 1.5	8L	50
(IE1-)K..R(Q)280 M2	970	1118	200 A	290	252	M63 x 1.5	200 A-SB	415	340	M63 x 1.5	8L	50
(IE1-)K..R(Q)280 M4, 6, 8	970	1118	200 A	290	252	M63 x 1.5	200 A-SB	415	340	M63 x 1.5	8L	50

Three-phase motors with squirrel-cage rotor for operation in Zone 2 according to EN 60079-15 (EN 60079-7)

Type of explosion protection „n“ (Increased safety „ec“) and and for operation in Zones 21 and 22 according to EN 60079-31, Type of explosion protection – Protection by enclosure „tb, tc“, Standard Efficiency IE1 (VIK Recommendation 1, Three-Phase Asynchronous Motors – Technical Requirements 03.2011)

with surface cooling, type of cooling IC 411
Size 315

Type of construction IM B5 [IM 3001] to Size 315 MY

Type of construction IM V1 [IM 3011]

Flange dimensions, see page 10/6

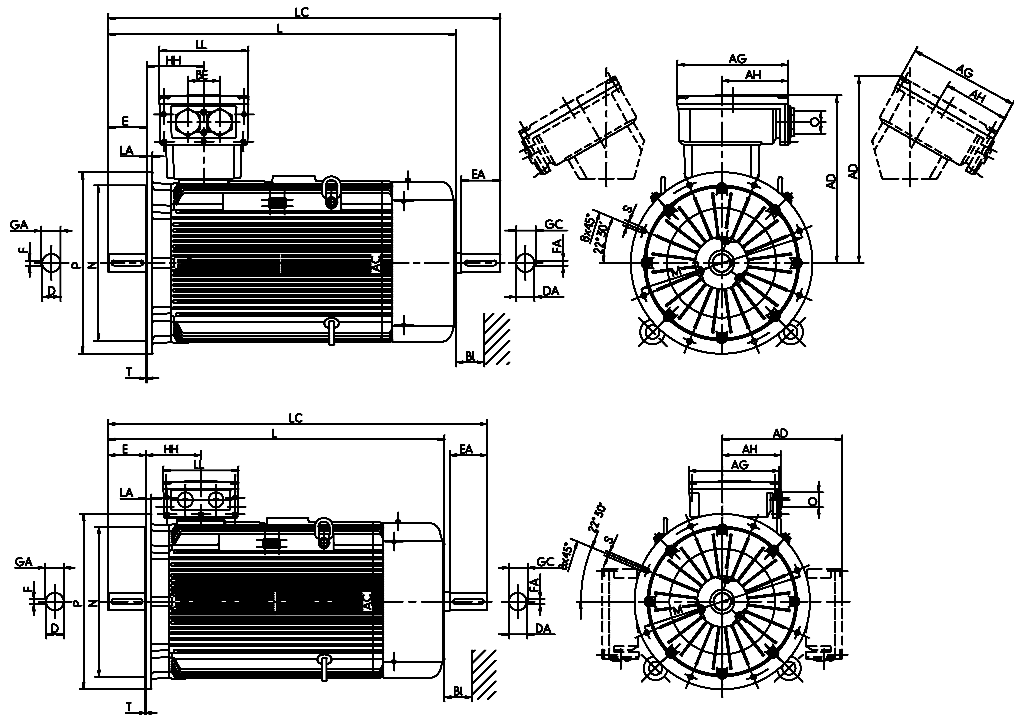

Type designation	Flange size	AC	AD	AD	D	DA	DB ¹⁾	E	EA	F	FA	GA	GC	H	HH	L	LC	TB Type	AG	LL	AH	O	BI
		g1																Ex e IIC Standard/ VIK	-	-	-	-	BI
		g	g1	(VIK)	d	d1		l	l1	u	u1	t	t1	h	A	k	k1						
(IE1-)K..R(Q)315 S2	FF 600	550	460	460	65	65	M20	140	140	18	18	69	69	315	211	1050	1218	400 A-SB	415	340	265	M63 x 1.5	55
(IE1-)K..R(Q)315 S4, 6, 8	FF 600	550	460	460	80	70	M20	170	140	22	20	85	74.5	315	211	1080	1248	400 A-SB	415	340	265	M63 x 1.5	55
(IE1-)K..R(Q)315 M2	FF 600	550	460	460	65	65	M20	140	140	18	18	69	69	315	211	1105	1273	400 A-SB	415	340	265	M63 x 1.5	55
(IE1-)K..R(Q)315 M4, 6, 8	FF 600	550	460	460	80	70	M20	170	140	22	20	85	74.5	315	211	1135	1303	400 A-SB	415	340	265	M63 x 1.5	55
(IE1-)K..R(Q)315 MX2	FF 600	550	460	460	65	65	M20	140	140	18	18	69	69	315	211	1185	1353	400 A-SB	415	340	265	M63 x 1.5	55
(IE1-)K..R(Q)315 MX4	FF 600	550	460	460	80	70	M20	170	140	22	20	85	74.5	315	211	1215	1383	400 A-SB	415	340	265	M63 x 1.5	55
(IE1-)K..R(Q)315 MX6, 8	FF 600	550	460	460	80	70	M20	170	140	22	20	85	74.5	315	211	1135	1303	400 A-SB	415	340	265	M63 x 1.5	55
(IE1-)K..R(Q)315 MX10, 12	FF 600	550	460	460	80	70	M20	170	140	22	20	85	74.5	315	211	1135	1303	400 A-SB	415	340	265	M63 x 1.5	55
(IE1-)K..R(Q)315 MY2	FF 600	610	681	681	65	65	M20	140	140	18	18	69	69	315	230	1270	1448	630 A	496	390	301	M63 x 1.5	55
(IE1-)K..R(Q)315 MY4, 6, 8	FF 600	610	681	681	80	70	M20	170	140	22	20	85	74.5	315	230	1300	1478	630 A	496	390	301	M63 x 1.5	55
(IE1-)K..R(Q)315 L2	FF 600	610	681	681	65	65	M20	140	140	18	18	69	69	315	230	1390	1543	630 A	496	390	301	M63 x 1.5	55
(IE1-)K..R(Q)315 L4, 6, 8	FF 600	610	681	681	80	70	M20	170	140	22	20	85	74.5	315	230	1420	1598	630 A	496	390	301	M63 x 1.5	55
(IE1-)K..R(Q)315 LX2	FF 600	610	681	681	65	65	M20	140	140	18	18	69	69	315	230	1510	1688	630 A	496	390	301	M63 x 1.5	55
(IE1-)K..R(Q)315 LX4	FF 600	610	681	681	80	70	M20	170	140	22	20	85	74.5	315	230	1540	1723	630 A	496	390	301	M63 x 1.5	55
(IE1-)K..R(Q)315 LX6, 8	FF 600	610	681	681	80	70	M20	170	140	22	20	85	74.5	315	230	1420	1598	630 A	496	390	301	M63 x 1.5	55

¹⁾ Centre holes to DIN 332-DS ...

Three-phase motors with squirrel-cage rotor for operation in Zone 2 according to EN 60079-15 (EN 60079-7)

Type of explosion protection „n“ (Increased safety „ec“) and and for operation in Zones 21 and 22 according to EN 60079-31, Type of explosion protection – Protection by enclosure „tb, tc“, Standard Efficiency IE1 (VIK Recommendation 1, Three-Phase Asynchronous Motors – Technical Requirements 03.2011))

with surface cooling, type of cooling IC 411
Size 355

Type of construction IM B3 [IM 1001]

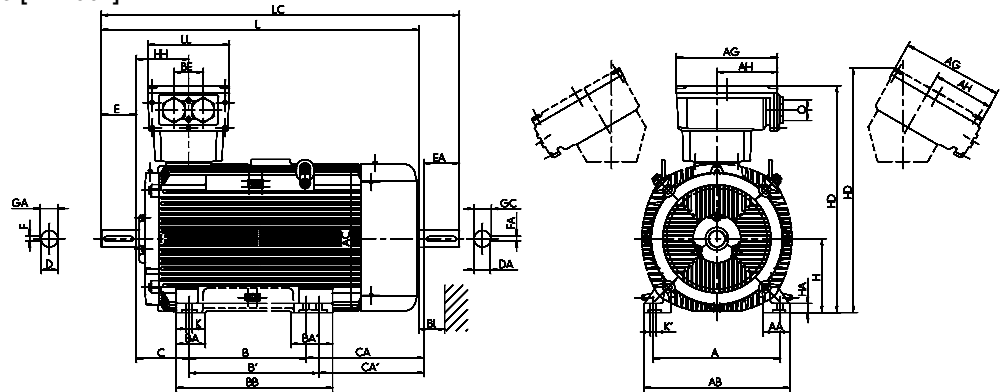

Type of construction IM B35 [IM 2001]

Flange dimensions, see page 10/6

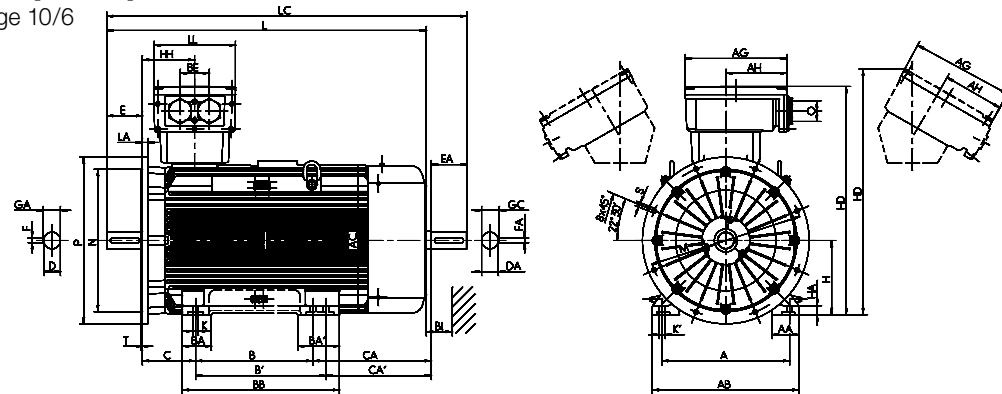

Type designation	Flange size	A	AA	AB	AC	B	BA	BA'	BB	C	CA	D	DA	DB ¹⁾	E	EA	F	FA
	b	n	f	g	a	m	m1	e	w1	w2	d	d1		l	l1	u	u1	
(IE1-)K.2R 355 MY2G, M2G	FF 740	610	130	700	715	560	140	200	750	254	-	80	80	M20	170	-	22	-
(IE1-)K.2R 355 MY4, 6, 8	FF 740	610	130	700	715	560	140	200	750	254	561	100	80	M24	210	170	28	22
(IE1-)K.2R 355 M4	FF 740	610	130	700	715	560	140	200	750	254	561	100	80	M24	210	170	28	22
(IE1-)K.2R 355 M6, 8	FF 740	610	130	700	715	560	140	200	750	254	561	100	80	M24	210	170	28	22
(IE1-)K.2R 355 MX6, 8	FF 740	610	130	700	715	560	140	200	750	254	681	100	80	M24	210	170	28	22
(IE1-)K.2R 355 MX2G	FF 740	610	130	700	715	560	140	200	750	254	-	80	80	M20	170	-	22	-
(IE1-)K.2R 355 LY2G, L2G	FF 740	610	130	700	715	630	140	200	750	254	-	80	80	M20	170	-	22	-
(IE1-)K.2R 355 MX4	FF 740	610	130	700	715	560	140	200	750	254	681	100	80	M24	210	170	28	22
(IE1-)K.2R 355 LY4, L4	FF 740	610	130	700	715	630	140	200	750	254	611	100	80	M24	210	170	28	22
(IE1-)K.2R 355 LY6, 8	FF 740	610	130	700	715	630	140	200	750	254	611	100	80	M24	210	170	28	22

Type designation	GA	GC	H	HA	HD	HD ²⁾	HH	K	K'	L	LC	TB Type Ex e IIC Standard/ VIK	AG	LL	AH	BE	0	BI
	t	t1	h	c	p	p	A	s	s'	k	k1		x	z	-	-	r	BI
(IE1-)K.2R 355 MY2G, M2G	85	-	355	44	1091	1172	250	28	35	1530	-	630 A	496	390	301	140	M75 x 1.5	60
(IE1-)K.2R 355 MY4, 6, 8	106	85	355	44	1091	1172	250	28	35	1570	1755	630 A	496	390	301	140	M75 x 1.5	60
(IE1-)K.2R 355 M4	106	85	355	44	1091	1172	250	28	35	1570	1755	630 A	496	390	301	140	M75 x 1.5	60
(IE1-)K.2R 355 M6, 8	106	85	355	44	1091	1172	250	28	35	1570	1755	630 A	496	390	301	140	M75 x 1.5	60
(IE1-)K.2R 355 MX6, 8	106	85	355	44	1091	1172	250	28	35	1690	1875	630 A	496	390	301	140	M75 x 1.5	60
(IE1-)K.2R 355 MX2G	85	-	355	44	1091	1172	327	28	35	1650	-	1000 A	615	474	385	200	M75 x 1.5	60
(IE1-)K.2R 355 LY2G, L2G	85	-	355	44	1084	1174	327	28	35	1650	-	1000 A	615	474	385	200	M75 x 1.5	60
(IE1-)K.2R 355 MX4	106	85	355	44	1084	1174	327	28	35	1690	1875	1000 A	615	474	385	200	M75 x 1.5	60
(IE1-)K.2R 355 LY4, L4	106	85	355	44	1084	1174	327	28	35	1690	1875	1000 A	615	474	385	200	M75 x 1.5	60
(IE1-)K.2R 355 LY6, 8	106	85	355	44	1084	1174	327	28	35	1690	1875	1000 A	615	474	385	200	M75 x 1.5	60

¹⁾ Centre holes to DIN 332-DS ...
²⁾ Terminal box inclined left/right

Three-phase motors with squirrel-cage rotor for operation in Zone 2 according to EN 60079-15 (EN 60079-7)

Type of explosion protection „n“ (Increased safety „ec“) and and for operation in Zones 21 and 22 according to EN 60079-31, Type of explosion protection – Protection by enclosure „tb, tc“, Standard Efficiency IE1 (VIK Recommendation 1, Three-Phase Asynchronous Motors – Technical Requirements 03.2011)

with surface cooling, type of cooling IC 411
Size 355

Type of construction IM V1 [IM 3011]
Flange dimensions, see page 10/6

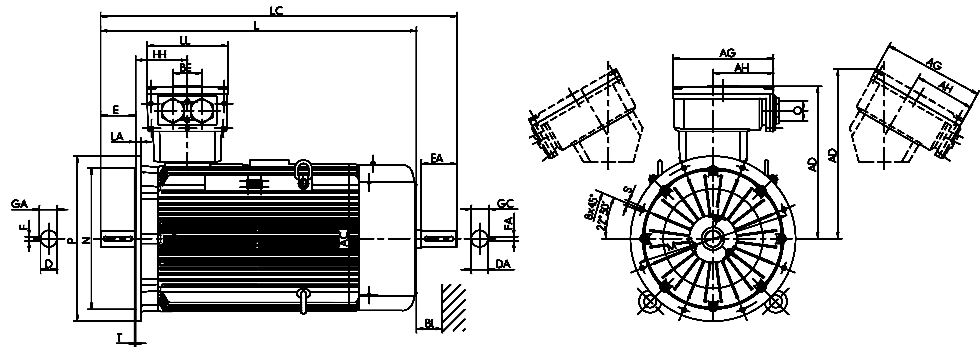

Type designation	Flange size	AC	AD	AD ^{*)}	D	DA	DB ^{*)}	E	EA	F	FA	GA	GC	H	HH	L	LC	TB Type	AG	LL	AH	BE	O	BI
		g	g1	g1	d	d1		l	l1	u	u1	t	t1	h	A	K	K1	VIK	x	z	-	-	r	BI
(IE1-)K.2R 355 MY2G, M2G	FF 740	715	736	817	80	80	M20	170	-	22	-	85	-	355	250	1530	-	630 A	496	390	301	140	M75 x 1.5	60
(IE1-)K.2R 355 MY4, 6, 8	FF 740	715	736	817	100	80	M24	210	170	28	22	106	85	355	250	1570	1755	630 A	496	390	301	140	M75 x 1.5	60
(IE1-)K.2R 355 M4	FF 740	715	736	817	100	80	M24	210	170	28	22	106	85	355	250	1570	1755	630 A	496	390	301	140	M75 x 1.5	60
(IE1-)K.2R 355 M6, 8	FF 740	715	736	817	100	80	M24	210	170	28	22	106	85	355	250	1570	1755	630 A	496	390	301	140	M75 x 1.5	60
(IE1-)K.2R 355 MX6, 8	FF 740	715	736	817	100	80	M24	210	170	28	22	106	85	355	327	1690	1875	630 A	496	390	301	140	M75 x 1.5	60
(IE1-)K.2R 355 MX2G	FF 740	715	729	819	80	80	M20	170	-	22	-	85	-	355	327	1650	-	1000 A	615	474	385	200	M75 x 1.5	60
(IE1-)K.2R 355 LY2G, L2G	FF 740	715	729	819	80	80	M20	170	-	22	-	85	-	355	327	1650	-	1000 A	615	474	385	200	M75 x 1.5	60
(IE1-)K.2R 355 MX4	FF 740	715	729	819	100	80	M24	210	170	28	22	106	85	355	327	1690	1875	1000 A	615	474	385	200	M75 x 1.5	60
(IE1-)K.2R 355 LY4, L4	FF 740	715	729	819	100	80	M24	210	170	28	22	106	85	355	327	1690	1875	1000 A	615	474	385	200	M75 x 1.5	60
(IE1-)K.2R 355 LY6, 8	FF 740	715	729	819	100	80	M24	210	170	28	22	106	85	355	327	1690	1875	1000 A	615	474	385	200	M75 x 1.5	60

^{*)} Centre holes to DIN 332-DS ...
^{**)} Terminal box inclined left/right



VEM MOTOR

Three-phase motors for marine use

Contents

Product description	11/2
Overview of technical data	11/7

Motor selection data

Series K.../W4.. for Premium Efficiency IE3	11/8
Series K.../WE.. for High Efficiency IE2	11/12
Series K..., (corresponds to Standard Efficiency IE1)	11/20

Bearings

Identical to bearings of standard motors,
see Chapter 2

Terminal boxes	11/28
----------------------	-------

Dimensions

Identical to dimension of standard motors,
see Chapter 2

Product description

The design and approval regulations of the classification societies must be observed at all stages of the design, manufacturing and testing of motors for marine use. The granting of a TYPE APPROVAL CERTIFICATE by the given classification society is a prerequisite for permission to manufacture the products to be supplied. When applying for such approval, the manufacturer must demonstrate the

suitability of the product by way of test, verification and material certificates. Testing, approval, certification and delivery are subject to the applicable test and approval regulations and supervised either by the internal quality management department or an inspector appointed by the classification society. Motors are designed according to the planned place of installation:

Operation on deck

Motors for “operation on deck” are offered as type series K10W or K11W for sizes 112–180, and KPO or KPEO for sizes 56–100. They are designed without an external fan and meet the specifications for degree of protection IP 56. As the motors possess no external fan, and

cooling is thus only by way of heat radiation, the outputs in continuous operation are reduced by approx. 30 to 40 % compared to the basic series. The relevant electrical data can be supplied upon request. Alternatively, details are also to be found in the electronic catalogue VEMeKAT.

Operation under deck

Motors for “operation under deck” are designed with a degree of protection matched to the intended place of installation:

- IP 55 for general use, e.g. in engine rooms.
- IP 56 for use in rooms where water splashing or gushes are to be expected.

Standards and regulations

Motors for marine use are manufactured to comply with the requirements of the classification societies

ABS	American Bureau of Shipping, USA
BV	Bureau Veritas, France
CCS	China Classification Society, China
GL	Germanischer Lloyd, Germany
DNV	Det Norske Veritas, Norway
DNV-GL	Det Norske Veritas-Germanischer Lloyd, Norway/Germany
LRS	Lloyds Register of Shipping, Great Britain

PRS	Polski Rejestr Statkow, Poland
RINA	REGISTRO ITALIANO NAVALE, Italy
RS	Maritime Register of Shipping, Russia

The classification societies divide main and auxiliary machines for on-board use into “essential services” and “non-essential services”. This assignment is important regarding the scope of prescribed spare parts and the question as to whether certain motors are to be subject to approval and supervision procedures.

Drives for essential services

Manufacturing in accordance with the relevant classification rules. A type approval certificate is the basic requirement up to a limit output specified by the individual classification society. For higher outputs, individual approval is required. Some classification societies also demand the supervision of

construction from a certain output.
Type 3.1 inspection certificate in accordance with EN 10204
Type 3.2 inspection certificate in accordance with EN 10204 only for certain classification societies and from a specified limit output.

Drives for non-essential services

Manufacturing in accordance with the relevant classification rules. A type approval certificate is not required and individual approval procedures only apply for motors with certification. Type 3.1 inspection certificate in accordance with EN 10204 only for motors with certification.

Technical data

Output data can be found in the motor selection tables. If a marine application requires compliance with additional regulations, e.g. gas or dust explosion protection, a corresponding motor series must be chosen.

Dimensions and types of construction

The mounting dimensions correspond to those of the basic version of series KPR/K10R or KPER/K11R, WE.R and W4.R.

Motors are available in construction types IM B3, IM B35, IM V1 and IM B5, subject to the restrictions which apply for the basic version.

Rated voltages and frequencies

Motors are available in the basic version for the following operating voltages and frequencies:

380 V, 50 Hz
400 V, 50 Hz
440 V, 60 Hz
460 V, 60 Hz

Deviating voltages and frequencies can be supplied upon request. Motors operating outside the output, voltage and/or speed ranges indicated in this special catalogue are similarly available upon request.

Overload

The motors comply with the following requirements of the classification societies named in the selection tables:

ABS	No special requirements
BV	160% rated torque for 15 s
GL	160% rated torque for 15 s. The breakdown torque must not be reached.
RS	200% rated torque for 15 s. The breakdown torque must not be reached.

LRS	as BV
DNV, DNV-GL	160% rated torque for 15 s at rated frequency and rated voltage
IEC/EN 60034	150% rated current at rated voltage for 2 min.

The rated current is specified in the selection tables for the rated voltages 380 and 400 V as well as 440, 460 and 480 V.

Approval, construction supervision and certificates

VEM motors GmbH has obtained TYPE APPROVAL CERTIFICATES from the following classification societies:

Bureau Veritas
China Classification Society
Det Norske Veritas
Germanischer Lloyd
DNV-GL
Lloyd's Register of Shipping
Russian Maritime Register of Shipping.

Copies of the certificates can be found on the company website at <http://www.vem-group.com> under the section "Downloads", sub-section "Classifications", topic "Marine

motors". The original documents are made available as PDF files. They are covered by the revision service and are thus always up to date. Motors for marine use in compliance with the requirements of further classification societies, for example ABS, RINA, Polski Rejestr Statkow and others, can be supplied upon request.

Certificates issued by Det Norske Veritas and Germanischer Lloyd remain valid until their specified date of expiry. Thereafter, the new DNV GL regulations apply.

Below, we have gathered a brief overview of the specific design and approval regulations of the individual classification societies:

Motors with protection against seawater according to "Bureau Veritas" <http://www.veristar.com>

Coolant temperature	45 °C
Thermal class	155 [F]
Temperature-rise limit of the winding	95 K
Individual approval for essential drives	> 100 kW
Construction supervision for essential drives	-
Approval mark stamped on the motor housing.	
Rating plate	Marking in English and French; coolant temperature 45 °C or separately agreed coolant temperature; marking "MV acc. to BV".



DNV GL – Business Assurance, Essen

Motors with protection against seawater according to “Germanischer Lloyd” *)
<http://www.gl-group.com/infoServices/rules/pdfs/glrp-e.pdf>



Coolant temperature	45 °C
Thermal class	155 [F]
Temperature-rise limit of the winding	100 K
Bearing temperature for antifriction bearings	75K
Individual approval for essential drives	≥ 50 kW for essential services
Construction supervision for essential drives	-
Rating plate	Marking in German and English; coolant temperature 45 °C or separately agreed coolant temperature; marking “SS nach GL”.

VEM motors GmbH Wernigerode is entitled to perform testing according to the rules of Germanischer Lloyd under its own responsibility. All certificates issued on this basis are verified by Germanischer Lloyd and confirmed by signature before final approval.

DNV GL – Business Assurance, Essen

Motors with protection against seawater according to “Det Norske Veritas” *)
<http://exchange.dnv.com/servicedocuments/dnv/dnvrulesforclassificationofships>



Coolant temperature	45 °C
Thermal class	155 [F]
Temperature-rise limit of the winding	100 K
Shaft steel	S355J2G3 with type 3.1 manufacturer’s certificate from a DNV approved manufacturer
Individual approval for essential drives	< 100 kW with manufacturer’s certificate; from 100 kW to < 300 kW DNV approval for shaft manufacturer and manufacturer’s certificate; 300 kW DNV approval
Construction supervision for essential drives	-
Rating plate	Marking in English and French; coolant temperature 45 °C or separately agreed coolant temperature, marking „MV acc. to DNV“

Following text in the type 3.1 manufacturer’s certificate: “DNV Rules for Ships, HSLC & MOU, TAC E-6737”

***) to be replaced by**

DNV GL Rules for Classification of Ships dated 28th October 2015

<http://exchange.dnv.com/servicedocuments/dnvgi/dnvglrulesforclassification>



Coolant temperature	45 °C
Thermal class	155 [F]
Temperature-rise limit of the winding	100 K
Shaft steel	S355J2G3 with type 3.1 manufacturer’s certificate from a DNV approved manufacturer
Individual approval for essential drives:	<100 kW with manufacturer’s certificate; > 100 kW to <300 kW DNV approval for shaft manufacturer and manufacturer’s certificate; approval required from 300 kW
Construction supervision for essential drives:	-
Rating plate	Marking in English and French; coolant temperature 45 °C or separately agreed coolant temperature; marking “MV acc. to DNV GL”.

Following text in the type 3.1 manufacturer’s certificate: “DNV GL Rules for Ships”

Motors with protection against seawater according to “Lloyd’s Register of Shipping”
<http://www.lr.org/code/home.htm>



Coolant temperature	45 °C
Thermal class	155 [F]
Temperature-rise limit of the winding	95 K
Shaft steel	from a manufacturer approved by LROS
Individual approval for essential drives	≥ 100 kW
Construction supervision for essential drives	≥ 100 kW
Rating plate	Marking in English and French; coolant temperature 45 °C or separately agreed coolant temperature; marking “MV acc. to LROS”.

Motors with protection against seawater according to “Russian Maritime Register of Shipping”
<http://www.rs-head.spb.ru>



Ambient temperature	45 °C
Thermal class	155 [F]
Temperature-rise limit of the winding	105 K
Individual approval for essential drives	> 55 kW
Construction supervision for essential drives	-

The Russian Maritime Register of Shipping has authorised the quality management department of VEM motors GmbH Wernigerode to perform motor approval inspections on the basis of the Agreement on Supervision No. 99.204.272 and the existing type approval certificate. The inspection certificates must be submitted to the Russian Maritime Register of Shipping for confirmation.

Rating plate	Marking in English and Russian; coolant temperature 45 °C or separately agreed coolant temperature; marking “MV acc. to RS”.
--------------	--

Motors with protection against seawater according to “China Classification Society”
<http://www.ccs.org.cn>



Coolant temperature	45 °C
Thermal class	155 [F]
Temperature-rise limit of the winding	105 K for motors ≥ 600 W and for self-ventilated motors (IC 410); 100 K for motors above 600 W
Shaft steel	CCS approval required for propulsion motors and drives (where the shaft is part of the drive)
Individual approval for essential drives	> 50 kW for essential services
Construction supervision for essential drives	-
Rating plate	Marking in English and French; coolant temperature 45 °C or separately agreed coolant temperature; marking “MV acc. to CCS”.

Motors with protection against seawater according to “American Bureau of Shipping”
<http://www.eagle.org>



Coolant temperature	50 °C for engine rooms 45 °C for all other places of installation
Thermal class	155 [F]
Temperature-rise limit of the winding	95 K
Individual approval for essential drives	≥ 100 kW
Construction supervision for essential drives	≥ 100 kW
Rating plate	Marking in German and English; Ambient temperature 45 °C or separately agreed coolant temperature; marking “MV acc. to ABS”

Verification has been granted for the drawings of motors up to an output of > 100 kW; in case of higher outputs, separate drawing verification is required for the individual motor. The following information is required for drawing verification and must be provided by the customer when placing the order:

- Contracted shipyard, name, address
- ABS construction no. or name of the vessel
- Drive purpose of the motor

Motors with protection against seawater according to “Polski Rejestr Statkow”

<http://www.prs.pl>

Individual approval through “Germanischer Lloyd” where appropriate



Ambient temperature	45 °C
Thermal class	155 [F]
Temperature-rise limit of the winding	95 K
Individual approval for essential drives	≥ 50
Construction supervision for essential drives	-
Rating plate	Marking in German and English; Ambient temperature 45 °C or separately agreed coolant temperature; marking “MV acc. to PRS”.

Motors with protection against seawater according to “REGISTRO ITALIANO NAVALE”

<http://www.rina.org>

Individual approval through “Germanischer Lloyd” where appropriate



RINA

Ambient temperature	45 °C
Thermal class	155 [F]
Temperature-rise limit of the winding	95 K
Individual approval for essential drives	≥ 50 kW
Construction supervision for essential drives	-
Rating plate	Marking in German and English; Ambient temperature 45 °C or separately agreed coolant temperature; marking “MV acc. to RINA”.

Overview of technical data

The most important technical data are summarised in the following table. Further information can be taken from the catalogue section Introduction, chapter 1.

Product group	Squirrel-cage rotor, IEC/EN
Classification societies	DNV ^{*)} , GL ^{*)} , DNV GL, BV, LRS, RS, RINA, CCS, ABS, PRS
Rated output	0.06 to 500 kW (IE1, IE2 and IE3 versions with 2, 4, 6 and 8 poles)
Sizes	56 to 355
Housing material	Grey cast iron
Rated torque	0.4 to 5800 Nm
Efficiency classification/ efficiency determination	IEC/EN 60034-30-1 / IEC/EN 60034-2-1, ≤ 1 kW direct measurement, > 1 kW residual loss method
Method of connection	Single-speed motors are designed in star-delta configuration as standard.
Stator winding insulation	Thermal class 155, optional 155 [F(B)], 180 to IEC/EN 60034-1
Degree of protection	IP 55 to IEC/EN 60034-5
Type of cooling	IC 411, IC 416, IC 71W (IC 31W) to IEC/EN 60034-6
Coolant temperature/ installation altitude	Standard -20 °C to +40 °C, Altitude 1000 m above sea level
Rated voltage	Standard voltages to EN 60038 50 Hz: 230 V, 400 V, 500 V, 690 V 60 Hz: 275 V, 460 V, 480 V, 600 V Voltage ranges A and B to IEC/EN 60034-1 (Prior consultation necessary regarding 230 V, 50 Hz and 275 V, 60 Hz for motors from size 315)
Duty types	S1, continuous duty, Short-time duty S2, 10/30/60 min Duty type S3/S6, 25/40/60 % c.d.f.
Types of construction	IM B3, IM B35, IM B5 and derived types to IEC/EN 60034-7
Paint finish	Normal finish "Moderate", colour RAL 7031, blue-grey Special finish "Worldwide", colour RAL 7031, blue-grey
Vibration severity grade	Grade "A" as standard for machines with no special vibration requirements
Shaft ends	to DIN 748 (IEC 60072), balanced with half-key
Limit speeds	Please refer to the section of "Limit speeds" in catalogue section "Motors for converter-fed operation", Chapter 4.
Bearing design	Please refer to the tables of "Bearing design data" in catalogue section „Standand motors“, Chapter 2.
Motor mass	Please refer to the technical selection lists.
Terminal boxes	Please refer to the section "Terminal boxes".
Documentation	An operating and maintenance manual, a terminal plan and a safety data sheet are supplied with each motor.
Tolerances	Please refer to the section "Tolerances" in catalogue section "Introduction", Chapter 1.
Options	Please refer to the section "Overview of modifications" in catalogue section "Introduction", Chapter 1.

^{*)} to be replaced by DNV GL Rules for Classification of Ships dated 28th October 2015

Motor selection data

Three-phase motors with squirrel-cage rotor for marine use, Premium Efficiency IE3

with surface cooling, duty type S1, continuous duty
for rated voltage, thermal class 155 (F), degree of protection IP 55, 50 Hz

Motor selection data														Design point 400 V, 50 Hz	
Type	Type	P _B	M _B	n _B	η _B			cosφ _B	I _B	I _A /I _B	M _A /M _B	M _S /M _B	M _K /M _B	J	m
GL	DNV, RS, LR				(EN 60034-2-1)				400 V						
DNV-GL	BV, ABS, CCS														
RS (KP.. only)		kW	Nm	rpm	100%	75%	50%	-	A	-	-	-	-	kgm ²	kg
Synchronous 3000 rpm – 2-pole version															
IE3-KPR 56 G2	KPR 56 G2 IE3	0.12	0.4	2830	IE3- 60.8	59.4	55.9	0.77	0.31	4.5	2.1	2.1	2.3	0.00013	4.5
IE3-KPR 63 K2	KPR 63 K2 IE3	0.18	0.61	2840	IE3- 65.9	64.6	59.8	0.84	0.44	5.5	2.5	2.4	2.9	0.00025	6.3
IE3-KPR 63 G2	KPR 63 G2 IE3	0.25	0.85	2825	IE3- 69.7	70.1	67.1	0.83	0.55	4.9	2.4	2.2	2.7	0.00025	6.3
IE3-KPR 71 K2	KPR 71 K2 IE3	0.37	1.24	2860	IE3- 73.8	71.7	70.3	0.87	0.78	7.1	2.9	2.7	3.1	0.00057	10.0
IE3-KPR 71 G2	KPR 71 G2 IE3	0.55	1.83	2870	IE3- 77.8	77.4	74.5	0.86	1.14	7.4	3.0	2.7	3.3	0.00072	11.2
IE3-KPR 80 K2	KPR 80 K2 IE3	0.75	2.49	2875	IE3- 80.7	82.7	80.7	0.89	1.48	7.7	2.2	2.1	2.7	0.00132	15.0
IE3-KPR 80 G2	KPR 80 G2 IE3	1.1	3.64	2885	IE3- 82.7	82.1	81.3	0.89	2.15	7.8	2.5	2.3	2.8	0.0017	18.0
IE3-KPR 90 S2	KPR 90 S2 IE3	1.5	4.92	2910	IE3- 84.2	86.6	84.5	0.86	2.9	9.1	3.0	2.7	3.7	0.00275	23.5
IE3-KPR 90 L2	KPR 90 L2 IE3	2.2	7.23	2905	IE3- 85.9	87.7	86.0	0.89	4.05	8.6	2.7	2.3	3.7	0.00333	29.0
IE3-KPR 100 L2	KPR 100 L2 IE3	3.0	9.74	2940	IE3- 87.1	86.4	83.5	0.8	6.2	10.1	3.3	2.9	4.8	0.0055	38.0
IE3-KPER 112 M2	KPER 112 M2 IE3	4.0	13.0	2930	IE3- 88.1	89.3	88.1	0.85	7.6	9.0	2.7	2.4	3.7	0.0068	46.0
IE3-KPR 112 M2	KPR 112 M2 IE3	4.0	13.0	2930	IE3- 89.2	89.2	87.9	0.87	7.4	6.9	1.5	1.2	2.9	0.011	60.0
IE3-KPER 132 S2	KPER 132 S2 IE3	5.5	17.9	2935	IE3- 89.2	87.5	85.1	0.80	11.2	9.1	2.8	2.2	4	0.011	65.0
IE3-W41R 132 SX2	K11R 132 SX2 IE3	7.5	24.0	2925	IE3- 90.1	89.4	87.9	0.87	14.0	8.0	2.5	2.1	3.3	0.0168	75
IE3-W41R 160 M2	K11R 160 M2 IE3	11	36.0	2950	IE3- 91.4	91.7	90.5	0.90	19.5	8.0	2.2	1.8	3.2	0.0575	125
IE3-W41R 160 MX2	K11R 160 MX2 IE3	15	49.0	2950	IE3- 91.9	92.0	91.3	0.91	26.0	7.9	2.2	1.7	3.1	0.0675	145
IE3-W41R 160 L2	K11R 160 L2 IE3	18.5	60.0	2960	IE3- 92.4	92.5	91.4	0.90	32.0	9.2	2.6	2.1	3.6	0.078	160
IE3-W41R 180 M2C	K11R 180 M2C IE3	22	71	2975	IE3- 92.7	92.6	91.5	0.91	37.5	8.9	1.9	1.4	3.3	0.1717	214
IE3-W41R 200 L2	K11R 200 L2 IE3	30	97	2965	IE3- 93.3	92.2	90.6	0.88	52.5	8.6	2.1	1.6	3.3	0.36	305
IE3-W41R 200 LX2C	K11R 200 LX2C IE3	37	119	2980	IE3- 93.7	92.9	91.7	0.89	64.0	8.7	1.7	1.3	3.2	0.4757	310
IE3-W41R 225 M2	K11R 225 M2 IE3	45	145	2960	IE3- 94.0	93.7	93.0	0.89	77.5	8.8	2.3	1.9	3.2	0.375	375
IE3-W41R 250 M2	K11R 250 M2 IE3	55	177	2970	IE3- 94.6	94.4	93.6	0.91	92	8.9	2.2	1.9	3.2	0.65	510
IE3-W41R 280 S2	K11R 280 S2 IE3	75	241	2967	IE3- 94.7	94.5	93.9	0.89	128	8.1	1.9	1.9	2.8	0.65	500
IE3-W41R 280 M2	K11R 280 M2 IE3	90	289	2970	IE3- 95	94.5	94	0.90	152	8.4	2.2		3.1	0.675	545
IE3-W41R 315 S2	K11R 315 S2 IE3	110	354	2970	IE3- 95.2	94.5	93.5	0.89	187	10.0	1.9	1.7	3.0	1.21	750
IE3-W41R 315 M2	K11R 315 M2 IE3	132	423	2980	IE3- 95.4	95.0	94.5	0.89	224	10.0	2.0	1.8	3.0	1.44	815
IE3-W41R 315 MX2	K11R 315 MX2 IE3	160	513	2980	IE3- 95.7	95.7	95.0	0.9	268	8.5	2.3	1.7	2.6	2.37	1095
IE3-W41R 315 MY2	K11R 315 MY2 IE3	200	641	2980	IE3- 95.8	95.9	95.5	0.91	331	8.3	2.6	1.6	2.4	2.82	1200
IE3-W41R 315 L2	K11R 315 L2 IE3	250	800	2985	IE3- 95.8	96.0	95.9	0.93	405	9.0	2.3	1.2	2.3	3.66	1460
IE3-W41R 315 LX2	K11R 315 LX2 IE3	315	1008	2985	IE3- 95.8	95.8	95.8	0.92	516	8.5	2.8	1.6	2.5	4.43	1700
IE3-W41R 355 M2	K22R 355 M2 IE3	355	1136	2985	IE3- 96.0	96.0	96.0	0.92	580	7.7	1.9	1.5	3.8	4.20	2000
Synchronous 1500 rpm – 4-pole version															
IE3-KPER 63 K4	KPER 63 K4 IE3	0.12	0.84	1365	IE3- 64.8	64.5	59.7	0.72	0.35	3.2	1.9	1.8	2.2	0.00024	5.2
IE3-KPR 63 G4	KPR 63 G4 IE3	0.18	1.21	1415	IE3- 69.9	67.2	61.2	0.67	0.57	4.4	1.8	1.8	2.7	0.0005	7.1
IE3-KPR 71 K4	KPR 71 K4 IE3	0.25	1.67	1430	IE3- 73.5	73.1	69.6	0.71	0.66	5.6	2.5	2.3	2.9	0.00087	9.9
IE3-KPR 71 G4	KPR 71 G4 IE3	0.37	2.5	1430	IE3- 77.3	78.2	73.1	0.69	0.98	6.2	2.8	2.6	3.2	0.00107	11.0
IE3-KPR 80 K4	KPR 80 K4 IE3	0.55	3.67	1430	IE3- 80.8	81.0	80.1	0.80	1.25	6.0	2.4	2.3	2.7	0.00207	14.5
IE3-KPR 80 GX4	KPR 80 GX4 IE3	0.75	5	1440	IE3- 82.5	82.3	79.6	0.74	1.75	7.1	3.4	3.3	4.2	0.0028	17.5
IE3-KPR 90 S4	KPR 90 S4 IE3	1.1	7.24	1450	IE3- 84.1	83.5	80.0	0.74	2.55	8.0	3.6	3.5	4.2	0.0045	28.0
IE3-KPR 90 LX4	KPR 90 LX4 IE3	1.5	9.85	1455	IE3- 85.3	84.5	81.7	0.73	3.45	9.5	4.5	3.8	4.9	0.0058	31.0
IE3-KPR 100 L4	KPR 100 L4 IE3	2.2	14.49	1455	IE3- 86.7	87.0	85.1	0.81	4.55	8.2	2.9	2.7	3.8	0.011	45.0
IE3-KPR 100 LZ4	KPR 100 LZ4 IE3	3.0	19.7	1455	IE3- 87.7	87.6	86.1	0.77	6.4	8.6	3.2	3.1	4.1	0.013	50.0
IE3-KPR 112 M4	KPR 112 M4 IE3	4.0	26.1	1465	IE3- 88.6	88.3	86.2	0.83	7.9	10.2	3.2	2.9	5	0.02	65.0
IE3-W41R 132 S4	K11R 132 S4 IE3	5.5	35	1480	IE3- 91.0	90.2	87.8	0.73	12.0	9.9	3.4	2.8	5.4	0.035	90
IE3-W41R 132 M4	K11R 132 M4 IE3	7.5	49	1475	IE3- 91.3	91.3	90.1	0.83	14.5	8.6	2.4	2.0	3.9	0.043	100
IE3-W41R 160 M4	K11R 160 M4 IE3	11	71	1475	IE3- 91.4	91.5	90.5	0.83	21.0	7.5	2.5	2.0	3.2	0.078	125
IE3-W41R 160 L4C	K11R 160 L4C IE3	15	96	1490	IE3- 92.8	92.5	91.0	0.83	28.0	10.5	2.8	2.4	3.9	0.1567	175
IE3-W41R 180 M4	K11R 180 M4 IE3	18.5	120	1475	IE3- 92.7	92.9	92.0	0.84	34.5	6.9	1.9	1.7	3.0	0.168	210
IE3-W41R 180 L4	K11R 180 L4 IE3	22	142	1480	IE3- 93.0	93.0	92.1	0.84	40.5	7.6	2.2	2.0	3.2	0.203	240
IE3-W41R 200 L4C	K11R 200 L4C IE3	30	193	1485	IE3- 93.6	92.4	92.4	0.85	54.5	7.0	1.6	1.4	2.6	0.411	327
IE3-W41R 225 S4C	K11R 225 S4C IE3	37	237	1490	IE3- 93.9	93.8	93.2	0.85	67.0	7.4	1.9	1.4	2.7	0.4675	367
IE3-W41R 225 M4	K11R 225 M4 IE3	45	290	1482	IE3- 94.2	94.3	94.0	0.82	84	8.1	2.6	2.1	2.6	0.619	450
IE3-W41R 250 M4	K11R 250 M4 IE3	55	354	1485	IE3- 94.7	94.8	94.4	0.83	101	8.1	2.1	1.8	2.5	0.95	550
IE3-W41R 280 S4	K11R 280 S4 IE3	75	482	1485	IE3- 95.0	94.6	94.2	0.83	137	8.2	2.1	1.8	2.5	1.1	617
IE3-W41R 280 M4	K11R 280 M4 IE3	90	578	1487	IE3- 95.2	94.7	94.0	0.83	164	9.2	2.1	1.9	2.7	1.96	785
IE3-W41R 315 S4	K11R 315 S4 IE3	110	706	1487	IE3- 95.4	95.0	94.3	0.82	203	9.5	1.9	1.7	2.7	1.96	760
IE3-W41R 315 M4	K11R 315 M4 IE3	132	849	1485	IE3- 95.6	95.4	95.0	0.83	240	9.0	2.2	1.9	2.7	2.27	850
IE3-W41R 315 MX4	K11R 315 MX4 IE3	160	1026	1490	IE3- 95.8	95.8	95.0	0.84	287	9.5	2.1	2.0	3.2	4.01	1120
IE3-W41R 315 MY4	K11R 315 MY4 IE3	200	1282	1490	IE3- 96.0	95.8	95.5	0.87	346	9.5	2.1	1.7	2.7	4.82	1250
IE3-W41R 315 L4	K11R 315 L4 IE3	250	1602	1490	IE3- 96.2	96.2	96.0	0.87	431	9.4	2.2	1.8	2.7	5.93	1450
IE3-W41R 315 LX4	K11R 315 LX4 IE3	315	2019	1490	IE3- 96.0	96.0	96.0	0.87	544	9.5	2.3	1.7	2.9	6.82	1630
IE3-W41R 355 M 4	K22R 355 M 4 IE3	355	2271	1493	IE3- 96.2	96.2	95.5	0.87	612	8.1	1.3	1.0	2.7	7.90	2150

Three-phase motors with squirrel-cage rotor for marine use, Premium Efficiency IE3

with surface cooling, duty type S1, continuous duty
for rated voltage, thermal class 155 (F), degree of protection IP 55, 50 Hz

Motor selection data													Design point 400 V, 50 Hz			
Type	Type	P _B	M _B	n _B	η _B			cosφ _B	I _B	I _N /I _B	M _A /M _B	M _S /M _B	M _K /M _B	J	m	
GL	DNV, RS, LR				(EN 60034-2-1)				400 V							
DNV-GL	BV, ABS, CCS															
RS (KP... only)		kW	Nm	rpm	100 %	75 %	50 %	-	A	-	-	-	-	kgm ²	kg	
Synchronous 1000 rpm – 6-pole version																
IE3-KPR 63 G6	KPR 63 G6 IE3	0.12	1.23	930	IE3- 57.7	60.0	54.0	0.56	0.53	2.8	1.9	1.8	2.1	0.00045	6.7	
IE3-KPR 71 K6	KPR 71 K6 IE3	0.18	1.85	930	IE3- 63.9	62.9	57.5	0.68	0.57	3.4	2.0	2.0	2.2	0.0013	11.0	
IE3-KPR 71 G6	KPR 71 G6 IE3	0.25	2.55	935	IE3- 68.6	66.9	62.2	0.67	0.75	3.9	2.3	2.3	2.5	0.00175	12.5	
IE3-KPR 80 K6	KPR 80 K6 IE3	0.37	3.72	950	IE3- 73.5	72.9	69.2	0.70	1.03	4.0	1.9	1.9	2.4	0.00325	15.0	
IE3-KPR 80 G6	KPR 80 G6 IE3	0.55	5.53	950	IE3- 77.2	75.9	72.4	0.69	1.50	4.1	2.1	2.1	2.5	0.00425	18.0	
IE3-KPR 90 S6	KPR 90 S6 IE3	0.75	7.54	950	IE3- 78.9	79.7	77.5	0.73	1.87	5.3	2.4	2.2	2.9	0.0072	30.0	
IE3-KPR 90 L6	KPR 90 L6 IE3	1.1	11.0	955	IE3- 81.0	81.0	78.5	0.71	2.75	5.4	2.5	2.4	2.8	0.0072	30.0	
IE3-KPR 100 LX6	KPR 100 LX6 IE3	1.5	15.0	955	IE3- 82.5	83.5	81.5	0.76	3.45	5.9	2.3	2.2	2.8	0.0139	36.0	
IE3-KPER 112 MV6	KPER 112 MV6 IE3	2.2	22.0	955	IE3- 84.3	83.6	80.9	0.74	5.15	5.7	2.4	2.3	2.9	0.0155	48.0	
IE3-KPER 132 S6	KPER 132 S6 IE3	3.0	30.0	97	IE3- 85.6	85.3	82.5	0.74	6.8	7.2	2.8	2.7	4	0.029	70.0	
IE3-W41R 132 M6	K11R 132 M6 IE3	4	40.0	965	IE3- 86.8	87.0	86.0	0.80	8.3	4.8	1.7	1.4	2.4	0.043	75	
IE3-W41R 132 MX6	K11R 132 MX6 IE3	5.5	54.0	970	IE3- 88.6	88.6	87.2	0.80	11.0	6.0	2.1	1.7	3.0	0.053	105	
IE3-W41R 160 M6	K11R 160 M6 IE3	7.5	73.0	980	IE3- 90.2	90.0	88.3	0.83	14.5	6.4	2.4	2.0	3.0	0.145	145	
IE3-W41R 160 L6C	K11R 160 L6C IE3	11	107.0	985	IE3- 91.4	91.2	89.8	0.85	20.5	6.8	2.2	2	2.8	0.166	168	
IE3-W41R 180 L6C	K11R 180 L6C IE3	15	145.0	985	IE3- 91.2	91.3	90.2	0.87	27.5	6.8	2	1.7	2.7	0.3396	214	
IE3-W41R 200 L6	K11R 200 L6 IE3	18.5	180.0	980	IE3- 91.8	91.7	90.5	0.87	33.5	7.2	2.3	2	3	0.514	310	
IE3-W41R 200 LX6C	K11R 200 LX6C IE3	22	213.0	985	IE3- 92.2	91.5	90	0.87	39.5	7.6	2.1	1.7	2.9	0.6476	321	
IE3-W41R 225 M6	K11R 225 M6 IE3	30	291	984	IE3- 92.9	92.2	91.0	0.84	55.5	7.2	2.7	2.2	2.9	0.92	400	
IE3-W41R 250 M6	K11R 250 M6 IE3	37	359	985	IE3- 93.3	93.2	92.3	0.86	66.5	7.1	2.8	2.0	2.7	1.48	545	
IE3-W41R 280 S6	K11R 280 S6 IE3	45	434	990	IE3- 93.7	93.5	91.5	0.86	80.5	8.5	2.1	1.8	2.8	2.63	695	
IE3-W41R 280 M6	K11R 280 M6 IE3	55	531	990	IE3- 94.2	94.1	93.1	0.85	99	9.0	2.2	1.9	3.1	3.33	815	
IE3-W41R 315 S6	K11R 315 S6 IE3	75	723	990	IE3- 94.6	94.0	93.5	0.86	133	8.2	1.8	1.4	2.3	5.55	1060	
IE3-W41R 315 M6	K11R 315 M6 IE3	90	868	990	IE3- 94.9	94.0	93.0	0.86	159	8.5	2.2	1.7	2.8	6	1100	
IE3-W41R 315 MX6	K11R 315 MX6 IE3	110	1061	990	IE3- 95.1	95.0	94.5	0.86	194	8.5	2.5	1.7	2.7	6.67	1210	
IE3-W41R 315 L6	K11R 315 L6 IE3	132	1267	995	IE3- 95.4	95.0	94.5	0.87	230	9.0	2.8	2.0	3.2	8.6	1550	
IE3-W41R 355 M6	K22R 355 M6 IE3	160	1536	995	IE3- 95.6	95.0	94.6	0.82	295	8.0	2.1	0.0	2.7	8.2	1850	
IE3-W42R 355 MX6	K22R 355 MX6 IE3	200	1919	995	IE3- 95.8	95.5	95.0	0.83	363	9.0	1.9	1.7	2.7	12.10	2200	
IE3-W41R 355 L6	K22R 355 L 6 IE3	250	2395	997	IE3- 95.8	95.5	95.0	0.84	448	8.8	2.2	1.5	2.8	14.00	2400	
IE3-W41R 355 LX6	K22R 355 LX6 IE3	315	3023	995	IE3- 95.8	95.7	95.3	0.84	565	7.5	1.6	1.1	2.3	14.00	2400	
Synchronous 750 rpm – 8-pole version																
IE3-KPR 71 G8	KPR 71 G8 IE3	0.12	1.67	685	IE3- 50.7	48.8	43.0	0.64	0.48	2.6	1.7	1.7	2.0	0.0013	9.9	
IE3-KPER 80 K8	KPER 80 K8 IE3	0.18	2.53	680	IE3- 58.7	56.3	49.8	0.61	0.73	2.6	1.6	1.6	2.0	0.00175	12.0	
IE3-KPR 80 G8	KPR 80 G8 IE3	0.25	3.39	705	IE3- 64.1	64.3	58.4	0.59	0.93	3.0	1.4	1.4	2.1	0.003	14.0	
IE3-KPR 90 S8	KPR 90 S8 IE3	0.37	4.98	710	IE3- 69.3	69.0	64.4	0.63	1.20	3.6	2.1	2.1	2.3	0.00625	25.0	
IE3-KPR 90 L8	KPR 90 L8 IE3	0.55	7.5	700	IE3- 73.0	70.6	66.3	0.64	1.72	3.6	1.8	1.8	2.3	0.0072	26.0	
IE3-KPR 100 L8	KPR 100 L8 IE3	0.75	10.0	715	IE3- 75.0	75.9	71.3	0.63	2.25	4.4	2.5	2.5	2.8	0.0123	33.5	
IE3-KPR 100 LX8	KPR 100 LX8 IE3	1.1	14.8	710	IE3- 77.7	77.5	73.7	0.63	3.2	4.2	1.9	1.8	2.5	0.0139	36.0	
IE3-KPER 112 MZ8	KPER 112 MZ8 IE3	1.5	20.3	705	IE3- 79.7	78.8	75.8	0.66	4.2	4.7	2.7	2.7	3.2	0.018	50.0	
IE3-KPER 132 S8	KPER 132 S8 IE3	2.2	29.0	720	IE3- 80.5									0.043	70.0	
IE3-W41R 132 M8	K11R 132 M8 IE3	3	40	720	IE3- 83.5	83.5	81.4	0.72	7.0	3.9	1.6	1.4	2.1	0.043	74	
IE3-W41R 160 M8	K11R 160 M8 IE3	4	51	735	IE3- 87.0	86.7	83.8	0.71	9.4	5.4	2.5	2.2	2.9	0.113	119	
IE3-W41R 160 MX8	K11R 160 MX8 IE3	5.5	72	730	IE3- 87.5	87.5	85.6	0.73	12.5	4.7	1.9	1.7	2.5	0.145	143	
IE3-W41R 160 L8	K11R 160 L8 IE3	7.5	98	730	IE3- 87.9	87.6	85.6	0.73	17.0	5.1	2.1	1.8	2.7	0.166	155	
IE3-W41R 180 L8	K11R 180 L8 IE3	11	143	733	IE3- 89.3	89.0	87.1	0.75	23.5	5.4	2.1	1.9	2.8	0.228	175	
IE3-W41R 200 L8	K11R 200 L8 IE3	15	196	730	IE3- 89.6	90.0	89.0	0.80	30.0	5.3	1.8	1.7	2.5	0.324	235	
IE3-W41R 225 S8	K11R 225 S8 IE3	18.5			IE3- 90.1									0.514	310	
IE3-W41R 225 M8	K11R 225 M8 IE3	22	286	735	IE3- 91.5	91.6	90.6	0.79	44	5.7	2.3	2.0	2.5	0.825	360	
IE3-W41R 250 M8	K11R 250 M8 IE3	30	391	732	IE3- 91.3	91.9	91.4	0.81	58.5	5.4	2.0	1.8	2.3	0.92	420	
IE3-W41R 280 S8	K11R 280 S8 IE3	37	479	738	IE3- 92.0	92.0	90.8	0.78	74.5	5.9	2.3	1.8	2.4	1.55	555	
IE3-W41R 280 M8	K11R 280 M8 IE3	45	581	740	IE3- 93.0	93.0	92.4	0.78	89.5	6.5	1.7	1.5	2.4	2.63	700	
IE3-W41R 315 S8	K11R 315 S8 IE3	55	708	742	IE3- 93.3	93.3	92.4	0.78	109	7.0	1.9	1.7	2.5	3.33	805	
IE3-W41R 315 M8	K11R 315 M8 IE3	75	965	742	IE3- 93.8	94.2	93.8	0.81	142	7.0	1.9	1.7	2.3	5.55	1120	
IE3-W41R 315 MX8	K11R 315 MX8 IE3	90	1157	743	IE3- 94.3	94.4	93.6	0.80	172	7.9	2.4	2.0	2.7	6	1185	
IE3-W41R 315 MY8	K11R 315 MY8 IE3	110	1419	740	IE3- 93.8	94.0	93.8	0.82	206	6.5	1.9	1.5	2.1	6.76	1250	
IE3-W41R 315 L8	K11R 315 L8 IE3	132	1703	740	IE3- 94.2	94.2	93.5	0.80	253	8.0	2.4	1.9	2.7	8.71	1450	
IE3-W41R 355 MY8	K22R 355 MY8 IE3	160	2051	745	IE3- 94.3	94.3	94.0	0.82	299	6.6	1.2	1.0	2.6	9.3	1700	
IE3-W41R 355 M8	K22R 355 M8 IE3	200	2564	745	IE3- 94.7	94.9	94.2	0.81	376	7.0	1.0	1.0	2.7	9.5	1890	
IE3-W41R 355 LY8	K22R 355 LY8 IE3	230												15.8	2400	

Three-phase motors with squirrel-cage rotor for marine use, Premium Efficiency IE3

with surface cooling, duty type S1, continuous duty
for rated voltage, thermal class 155 (F), degree of protection IP 55, 60 Hz

Motor selection data														Design point 460 V, 60 Hz	
Type	Type	P _B	M _B	n _B	η _B			cosφ _B	I _B	I _A /I _B	M _A /M _B	M _S /M _B	M _K /M _B	J	m
GL	DNV, RS, LR				(EN 60034-2-1)				460 V						
DNV-GL	BV, ABS, CCS														
RS (KP.. only)		kW	Nm	rpm	100%	75%	50%	-	A	-	-	-	-	kgm ²	kg
Synchronous 3600 rpm – 2-pole version															
IE3-KPR 56 G2	KPR 56 G2 IE3	0.14	0.39	3410	IE3- 71.4	62.0	66.5	0.82	0.3	5.2	2.0	2.0	2.3	0.00013	4.5
IE3-KPR 63 K2	KPR 63 K2 IE3	0.21	0.58	3430	IE3- 65.6	***)	***)	0.83	0.44	5.5	2.6	2.5	3.1	0.00025	6.3
IE3-KPR 63 G2	KPR 63 G2 IE3	0.3	0.84	3410	IE3- 69.5	70.0	67.8	0.84	0.58	5.3	2.3	2.2	2.8	0.00025	6.3
IE3-KPR 71 K2	KPR 71 K2 IE3	0.44	1.21	3460	IE3- 73.4	83.9	82.4	0.86	0.78	7.3	3.0	2.8	3.2	0.00057	10.0
IE3-KPR 71 G2	KPR 71 G2 IE3	0.65	1.79	3465	IE3- 77.0	82.4	82.0	0.87	1.13	7.8	2.8	2.5	2.9	0.00072	11.2
IE3-KPR 80 K2	KPR 80 K2 IE3	0.75	2.05	3500	IE3- 83.0	83.5	80.6	0.87	1.30	8.5	2.5	2.1	3.0	0.00132	15.0
IE3-KPR 80 G2	KPR 80 G2 IE3	1.1	3.01	3490	IE3- 84.0	85.1	81.9	0.87	1.88	9.2	3.0	2.7	3.3	0.0017	18.0
IE3-KPR 90 S2	KPR 90 S2 IE3	1.5	4.90	3510	IE3- 85.5	87.3	84.3	0.88	2.9	8.1	2.1	2.0	3.1	0.00275	23.5
IE3-KPR 90 L2	KPR 90 L2 IE3	2.2	5.98	3515	IE3- 86.5	87.4	85.6	0.88	3.60	7.2	2.1	1.8	2.7	0.00333	29.0
IE3-KPR 100 L2	KPR 100 L2 IE3	3.6	9.71	3540	IE3- 88.5	88.0	85.7	0.82	6.20	9.8	2.8	2.3	4.4	0.0055	38.0
IE3-KPER 112 M2	KPER 112 M2 IE3	4.8	13.02	3520	IE3- 89.5	89.3	87.5	0.86	7.8	8.7	2.4	2.2	3.5	0.0068	46.0
IE3-KPR 112 M2	KPR 112 M2 IE3	4.5	12.16	3535	IE3- 88.5	88.3	86.3	0.88	7.3	6.7	1.5	1.2	2.9	0.011	60.0
IE3-KPER 132 S2	KPER 132 S2 IE3	6.4	17.00	3525	IE3- 89.5	88.5	86.0	0.85	10.4	7.2	1.8	1.3	3.3	0.011	65.0
IE3-W41R 132 SX2	K11R 132 SX2 IE3	9	24	3520	IE3- 90.5	89.5	87.8	0.89	14	7.1	2.3	1.9	3.1	0.0168	75
IE3-W41R 160 M2	K11R 160 M2 IE3	13.2	36	3540	IE3- 91	90	87.9	0.91	20	7.3	2	1.6	2	0.0575	125
IE3-W41R 160 MX2	K11R 160 MX2 IE3	18	48	3545	IE3- 92	92.3	91.2	0.92	26.5	7.4	2	1.6	2.9	0.0675	145
IE3-W41R 160 L2	K11R 160 L2 IE3	22	59	3550	IE3- 92	91.9	90.7	0.91	33	8.5	2.4	1.9	3.3	0.078	160
IE3-W41R 180 M2C	K11R 180 M2C IE3	26	70	3570	IE3- 92.4	92.0	90.7	0.92	38.5	8.2	1.8	1.3	3.0	0.1717	214
IE3-W41R 200 L2	K11R 200 L2 IE3	33	88	3565	IE3- 92.4	91.0	88.6	0.88	51.0	8.5	2.1	1.6	3.2	0.36	305
IE3-W41R 200 LX2C	K11R 200 LX2C IE3	40	107	3575	IE3- 93	91.7	89.5	0.89	60.5	8.8	1.8	1.3	3.2	0.4757	310
IE3-W41R 225 M2	K11R 225 M2 IE3	54	145	3553	IE3- 93.6	93.3	92.6	0.89	81.5	8.1	2.1	1.7	2.9	0.375	375
IE3-W41R 250 M2	K11R 250 M2 IE3	66	177	3568	IE3- 94.1	93.5	92.3	0.92	95.5	8.2	2	1.8	2.9	0.65	510
IE3-W41R 280 S2	K11R 280 S2 IE3	82	220	3566	IE3- 94.5	94	92.5	0.90	121	8.1	2	1.8	3	0.65	500
IE3-W41R 280 M2	K11R 280 M2 IE3													0.675	545
IE3-W41R 315 S2	K11R 315 S2 IE3	110	294	3570	IE3- 95.0	94.0	92.5	0.89	163	10	2	1.8	3.2	1.21	750
IE3-W41R 315 M2	K11R 315 M2 IE3	145	387	3580	IE3- 95.4	95.0	94.5	0.89	214	10	2	1.8	3	1.44	815
IE3-W41R 315 MX2	K11R 315 MX2 IE3	165	440	3585	IE3- 95.4	95	94	0.89	244	9	2.5	1.8	2.8	2.37	1095
IE3-W41R 315 MY2	K11R 315 MY2 IE3	220	587	3580	IE3- 95.8	95.3	94.5	0.91	317	8.5	2.8	1.7	2.7	2.82	1200
IE3-W41R 315 L2	K11R 315 L2 IE3													3.66	1460
IE3-W41R 315 LX2	K11R 315 LX2 IE3	340	906	3585	IE3- 95.8	95.8	95.5	0.92	484	9.1	2.9	1.6	2.5	4.43	1700
IE3-W41R 355 M2	K22R 355 M2 IE3													4.20	2000
Synchronous 1800 rpm – 4-pole version															
IE3-KPER 63 K4	KPER 63 K4 IE3	0.14	0.81	1660	IE3- 66.0	65.5	61.1	0.71	0.37	3.6	1.9	1.9	2.3	0.00024	5.2
IE3-KPR 63 G4	KPR 63 G4 IE3	0.21	1.16	1725	IE3- 69.5	68.8	62.9	0.66	0.56	4.8	2.6	2.6	2.9	0.0005	7.1
IE3-KPR 71 K4	KPR 71 K4 IE3	0.3	1.66	1725	IE3- 73.4	76.5	72.8	0.74	0.66	5.2	2.1	2.0	2.7	0.00087	9.9
IE3-KPR 71 G4	KPR 71 G4 IE3	0.44	2.44	1725	IE3- 78.2	77.8	74.3	0.72	0.96	6.1	2.5	2.4	3.2	0.00107	11.0
IE3-KPR 80 K4	KPR 80 K4 IE3	0.65	3.60	1725	IE3- 83.5	82.8	79.0	0.81	1.24	6.2	2.2	2.1	2.6	0.00207	14.5
IE3-KPR 80 GX4	KPR 80 GX4 IE3	0.75	4.94	1740	IE3- 83.5	83.3	80.5	0.79	1.77	7.4	3.3	3.2	4.2	0.0026	17.0
IE3-KPR 90 S4	KPR 90 S4 IE3	1.1												0.0045	28.0
IE3-KPR 90 LX4	KPR 90 LX4 IE3	1.5	9.82	1750	IE3- 86.5	85.3	82.1	0.77	3.4	8.8	3.8	3.4	4.7	0.0058	31.0
IE3-KPR 100 L4	KPR 100 L4 IE3	2.2												0.011	45.0
IE3-KPR 100 LZ4	KPR 100 LZ4 IE3	3.0	19.60	1750	IE3- 89.5	89.0	87.6	0.79	6.45	8.1	2.6	2.5	3.6	0.013	50.0
IE3-KPR 112 M4	KPR 112 M4 IE3	4.5	24.00	1765	IE3- 90.3	90.2	90.2	0.84	7.4	9.3	2.8	2.4	4.5	0.02	65.0
IE3-W41R 132 S4	K11R 132 S4 IE3	6.6	35	1780	IE3- 91.8	91	88.9	0.77	11.7	9.6	3.1	2.6	5	0.035	90
IE3-W41R 132 M4	K11R 132 M4 IE3	9	49	1765	IE3- 91.8	91.7	90.6	0.85	14.5	8	2.3	1.9	3.6	0.043	100
IE3-W41R 160 M4	K11R 160 M4 IE3	12.5	67	1775	IE3- 92.4	91.8	90.6	0.80	21.5	7.4	2.4	2	3.1	0.078	125
IE3-W41R 160 L4C	K11R 160 L4C IE3	18	96	1785	IE3- 93.6	92.8	91.3	0.85	28.5	9.9	2.6	2.2	3.6	0.1567	175
IE3-W41R 180 M4	K11R 180 M4 IE3	22	118	1775	IE3- 93.6	93.0	92.3	0.84	35.0	6.5	1.8	1.9	2.8	0.168	210
IE3-W41R 180 L4	K11R 180 L4 IE3	25	134	1775	IE3- 93.6	92.8	91.8	0.85	39.5	7.5	2.1	1.9	3.1	0.203	240
IE3-W41R 200 L4C	K11R 200 L4C IE3	30	160	1790	IE3- 94.1	92.8	91.0	0.84	47.5	7.7	1.7	1.5	2.8	0.411	327
IE3-W41R 225 S4C	K11R 225 S4C IE3	40	214	1785	IE3- 94.5	93.7	92.5	0.85	62.5	7.5	1.9	1.4	2.7	0.4675	367
IE3-W41R 225 M4	K11R 225 M4 IE3	49	263	1782	IE3- 95	94	91.5	0.83	79	8.7	2.7	2.2	2.7	0.619	450
IE3-W41R 250 M4	K11R 250 M4 IE3	55	294	1785	IE3- 95.4	94.9	93.5	0.83	87	8.9	2.3	2	2.7	0.95	550
IE3-W41R 280 S4	K11R 280 S4 IE3	90	482	1783	IE3- 95.4	94.6	94	0.84	141	7.9	2	1.7	2.3	1.1	617
IE3-W41R 280 M4	K11R 280 M4 IE3	90	480	1790	IE3- 95	95.4	93.2	0.82	144	10	2	1.9	2.9	1.96	785
IE3-W41R 315 S4	K11R 315 S4 IE3	125	668	1788	IE3- 95.8	95.2	94.3	0.83	197	9.2	2.1	2	2.7	1.96	760
IE3-W41R 315 M4	K11R 315 M4 IE3	129	689	1787	IE3- 95.8	95.3	94.7	0.83	204	10	2.3	2.1	2.9	2.27	850
IE3-W41R 315 MX4	K11R 315 MX4 IE3	175	934	1790	IE3- 96.2	96	95	0.84	272	9.5	2.1	2	3.2	4.01	1120
IE3-W41R 315 MY4	K11R 315 MY4 IE3	225	1200	1790	IE3- 96.2	96	95.5	0.85	345	10.5	2.6	1.9	3.1	4.82	1250
IE3-W41R 315 L4	K11R 315 L4 IE3	280	1494	1790	IE3- 96.2	96.1	95.7	0.87	420	9.3	2.2	1.8	2.7	5.93	1450
IE3-W41R 315 LX4	K11R 315 LX4 IE3	315	1680	1790	IE3- 96.2	96.2	95.5	0.87	472	10.5	2.6	1.9	3.2	6.82	1630
IE3-W41R 355 M4	K22R 355M 4 IE3	375	2001	1790	IE3- 96.2	95.8	95	0.87	647	9.1	1.3	1	3.2	7.90	2150

***) upon request

Three-phase motors with squirrel-cage rotor for marine use, Premium Efficiency IE3

with surface cooling, duty type S1, continuous duty
for rated voltage, thermal class 155 (F), degree of protection IP 55, 60 Hz

Motor selection data													Design point 460 V, 60 Hz		
Type	Type	P _B	M _B	n _B	η _B			cosφ _B	I _B	I _A /I _B	M _K /M _B	M _S /M _B	M _K /M _B	J	m
GL	DNV, RS, LR				(EN 60034-2-1)				460 V						
DNV-GL	BV, ABS, CCS														
RS (KP.. only)		kW	Nm	rpm	100%	75%	50%	-	A	-	-	-	-	kgm ²	kg
Synchronous 1200 rpm – 6-pole version															
IE3-KPR 63 G6	KPR 63 G6 IE3	0.14	1.18	1130	IE3- 64.0	62.1	56.2	0.54	0.5	3.1	1.8	1.8	2.2	0.00045	6.7
IE3-KPR 71 K6	KPR 71 K6 IE3	0.21	1.78	1125	IE3- 67.5	***)	***)	0.68	0.55	3.6	2.1	2.0	2.3	0.0013	11.0
IE3-KPR 71 G6	KPR 71 G6 IE3	0.3	2.55	1125	IE3- 71.4	***)	***)	0.70	0.73	4.4	2.4	2.4	2.7	0.00175	12.5
IE3-KPR 80 K6	KPR 80 K6 IE3	0.44	3.67	1145	IE3- 75.3	74.8	71.2	0.70	1.03	4.1	1.8	1.8	2.3	0.00325	15.0
IE3-KPR 80 G6	KPR 80 G6 IE3	0.45	3.67	1170	IE3- 75.3	75.0	69.4	0.58	1.25	5.1	3.0	3.0	3.6	0.00425	18.0
IE3-KPR 90 S6	KPR 90 S6 IE3	0.9	7.47	1150	IE3- 82.5	82.9	80.9	0.73	1.88	5.3	2.2	2.0	2.7	0.0072	30.0
IE3-KPR 90 L6	KPR 90 L6 IE3	0.92	7.51	1170	IE3- 82.3	80.02	74.53	0.62	2.26	6.8	3.5	3.0	4.2	0.0072	30.0
IE3-KPR 100 LX6	KPR 100 LX6 IE3	0.92	7.45	1180	IE3- 82.8	80	79.7	0.57	2.45	7.7	3.6	3.6	5.1	0.0139	36.0
IE3-KPER 112 MV6	KPER 112 MV6 IE3														
IE3-KPER 132 S6	KPER 132 S6 IE3														
IE3-W41R 132 M6	K11R 132 M6 IE3	4.5	37	1170	IE3- 89.5	88.7	87.6	0.80	7.9	4.8	1.7	1.5	2.4	0.043	75
IE3-W41R 132 MX6	K11R 132 MX6 IE3	5.7	46	1175	IE3- 91	89.8	87.5	0.79	10	6.5	2.2	1.9	3.2	0.053	105
IE3-W41R 160 M6	K11R 160 M6 IE3	9	73	1175	IE3- 91.3	90.6	89	0.85	14.6	6	2.2	1.9	2.8	0.145	145
IE3-W41R 160 L6C	K11R 160 L6C IE3	13	105	1185	IE3- 91.7	91.4	90	0.86	20.5	6.5	2.1	1.9	2.6	0.166	168
IE3-W41R 180 L6C	K11R 180 L6C IE3	18.5	149	1185	IE3- 93	91.9	90.5	0.85	29.5	6.2	1.8	1.5	2.5	0.3396	214
IE3-W41R 200 L6	K11R 200 L6 IE3	22	178	1180	IE3- 93	91.7	90.5	0.87	34	6.7	2.1	1.8	2.8	0.514	310
IE3-W41R 200 LX6C	K11R 200 LX6C IE3	22	177	1190	IE3- 93	91.4	89.4	0.87	34	6.5	2.4	1.9	3.2	0.6476	321
IE3-W41R 225 M6	K11R 225 M6 IE3				IE3-									0.92	400
IE3-W41R 250 M6	K11R 250 M6 IE3	40	322	1185	IE3- 94.1	93.3	92	0.86	62	7.2	2.9	2	2.8	1.48	545
IE3-W41R 280 S6	K11R 280 S6 IE3	45	362	1188	IE3-									2.63	695
IE3-W41R 280 M6	K11R 280 M6 IE3	55	440	1195	IE3- 94.5	94	92.5	0.85	86	9.5	2.5	2.2	3.4	3.33	815
IE3-W41R 315 S6	K11R 315 S6 IE3	85	683	1188	IE3-									5.55	1060
IE3-W41R 315 M6	K11R 315 M6 IE3	99	796	1188	IE3-									6	1100
IE3-W41R 315 MX6	K11R 315 MX6 IE3	120	965	1188	IE3-									6.67	1210
IE3-W41R 315 L6	K11R 315 L6 IE3	132	1055	1195	IE3- 95.8	95.3	94.4	0.84	206	9.5	3	2.2	3.5	8.6	1550
IE3-W41R 355 M6	K22R 355 M6 IE3	175	1400	1194	IE3-									8.2	1850
IE3-W42R 355 MX6	K22R 355 MX6 IE3	200	1600	1194	IE3-									12.10	2200
IE3-W41R 355 L6	K22R 355 L 6 IE3													14.00	2400
IE3-W41R 355 LX6	K22R 355 LX6 IE3	350		1196	IE3- 95.8	95.5	95.3	0.85	539	8	1.8	1.3	2.4	14.00	2400
Synchronous 900 rpm – 8-pole version															
IE3-KPR 71 G8	KPR 71 G8 IE3	0.14	1.59	840	IE3- 59.5	59.1	52.7	0.61	0.47	2.8	1.8	1.8	2.1	0.0013	9.9
IE3-KPER 80 K8	KPER 80 K8 IE3	0.21	2.39	840	IE3- 64.0	59.0	51.1	0.55	0.77	2.9	1.9	1.9	2.4	0.00175	12.0
IE3-KPR 80 G8	KPR 80 G8 IE3	0.3	3.33	860	IE3- 68.0	65.8	59.8	0.55	0.98	3.1	1.3	1.3	2.2	0.003	14.0
IE3-KPR 90 S8	KPR 90 S8 IE3	0.44	4.91	855	IE3- 72.0	69.3	64.8	0.63	1.22	3.2	1.6	1.6	1.9	0.00625	25.0
IE3-KPR 90 L8	KPR 90 L8 IE3	-	-	-	-	-	-	-	-	-	-	-	-	0.0072	26.0
IE3-KPR 100 L8	KPR 100 L8 IE3	0.9	9.95	865	IE3- 75.5	78.8	75.5	0.66	2.12	4.8	2.3	2.3	2.8	0.01225	33.5
IE3-KPR 100 LX8	KPR 100 LX8 IE3	1.25	13.90	860	IE3- 78.5	79.8	76.3	0.63	3.1	4.2	1.7	1.5	2.4	0.0139	36.0
IE3-KPER 112 MZ8	KPER 112 MZ8 IE3	1.25												0.0155	46.0
IE3-KPER 132 S8	KPER 132 S8 IE3													0.043	70.0
IE3-W41R 132 M8	K11R 132 M8 IE3	3												0.043	74
IE3-W41R 160 M8	K11R 160 M8 IE3	4.8	51	885	IE3- 88.4	87.9	85.4	0.72	9.5	5.1	2.3	2.0	2.6	0.113	119
IE3-W41R 160 MX8	K11R 160 MX8 IE3	5.5												0.145	143
IE3-W41R 160 L8	K11R 160 L8 IE3	7.5												0.166	155
IE3-W41R 180 L8	K11R 180 L8 IE3	11												0.228	175
IE3-W41R 200 L8	K11R 200 L8 IE3	18	196	878	IE3- 90.3	90.7	89.7	0.80	31.5	4.9	1.7	1.6	2.3	0.324	235
IE3-W41R 225 S8	K11R 225 S8 IE3	18.5												0.514	310
IE3-W41R 225 M8	K11R 225 M8 IE3	22												0.825	360
IE3-W41R 250 M8	K11R 250 M8 IE3	30												0.92	420
IE3-W41R 280 S8	K11R 280 S8 IE3	37												1.55	555
IE3-W41R 280 M8	K11R 280 M8 IE3	54	579	890	IE3- 93.6	93.0	92.4	0.79	91.5	6.0	1.5	1.3	2.1	2.63	700
IE3-W41R 315 S8	K11R 315 S8 IE3	55												3.33	805
IE3-W41R 315 M8	K11R 315 M8 IE3	75												5.55	1120
IE3-W41R 315 MX8	K11R 315 MX8 IE3	108	1152	895	IE3- 94.8	94.7	94.7	0.78	183	8.0	1.6	1.6	2.6	6	1185
IE3-W41R 315 MY8	K11R 315 MY8 IE3	120	1288	890	IE3- 94.2	94.2	94.2	0.82	195	6.6	1.8	1.6	2.2	6.76	1250
IE3-W41R 315 L8	K11R 315 L8 IE3	110												8.71	1450
IE3-W41R 355 MY8	K22R 355 MY8 IE3	132												9.3	1700
IE3-W41R 355 M8	K22R 355 M8 IE3	160												9.5	1890
IE3-W41R 355 LY8	K22R 355 LY8 IE3	200												15.8	2400

***) upon request

Three-phase motors with squirrel-cage rotor for marine use, High Efficiency IE2

with surface cooling, duty type S1, continuous duty
for rated voltage, thermal class 155 (F), degree of protection IP 55, 50 Hz

Motor selection data													Design point 400 V, 50 Hz		
Type	Type	P _B	M _B	n _B	η _B			cosφ _B	I _B	I _A /I _B	M _A /M _B	M _S /M _B	M _K /M _B	J	m
GL	DNV, RS, LR				(EN 60034-2-1)				400 V						
DNV-GL	BV, ABS, CCS														
RS (KP.. only)		kW	Nm	rpm	100%	75%	50%	-	A	-	-	-	-	kgm ²	kg
Synchronous 3000 rpm – 2-pole version															
IE2-KPR 56 G2	KPR 56 G2 IE2	0.12	0.41	2810	IE2- 53.6	65.5	61.6	0.83	0.31	4.7	2.0	2.0	2.2	0.00015	4.8
IE2-KPR 63 K2	KPR 63 K2 IE2	0.18	0.61	2840	IE2- 60.4	68.6	63.5	0.84	0.44	5.5	2.5	2.4	2.9	0.00025	6.3
IE2-KPR 63 G2	KPR 63 G2 IE2	0.25	0.83	2860	IE2- 64.8	77.6	73.6	0.84	0.55	6.2	2.6	2.5	2.8	0.00032	7
IE2-KPR 71 K2	KPR 71 K2 IE2	0.37	1.24	2860	IE2- 69.5	74.2	72.7	0.87	0.78	7.1	2.9	2.7	3.1	0.00057	10
IE2-KPR 71 G2	KPR 71 G2 IE2	0.55	1.83	2870	IE2- 74.1	78.3	75.4	0.86	1.14	7.4	3.0	2.7	3.3	0.00072	11.2
IE2-KPR 80 K2	KPR 80 K2 IE2	0.75	2.49	2880	IE2- 77.4	83.6	81.6	0.88	1.48	7.7	2.2	2.1	2.7	0.00132	15
IE2-KPR 80 G2	KPR 80 G2 IE2	1.1	3.64	2885	IE2- 79.6	82.1	81.2	0.89	2.15	7.8	2.5	2.3	2.8	0.0017	18
IE2-KPR 90 S2	KPR 90 S2 IE2	1.5	4.92	2910	IE2- 81.3	85.5	82.9	0.87	2.9	9.0	2.8	2.4	3.4	0.00275	23.5
IE2-KPR 90 L2	KPR 90 L2 IE2	2.2	7.29	2880	IE2- 83.2	85.7	83.9	0.88	4.25	8.0	2.5	2.3	2.9	0.00275	23.5
IE2-KPR 100 L2	KPR 100 L2 IE2	3	9.78	2930	IE2- 84.6	86.2	83.5	0.76	6.55	8.5	2.6	2.4	3.8	0.0045	31
IE2-KPER 112 MX2	KPER 112 MX2 IE2	4	13.08	2920	IE2- 85.8	86.4	85.8	0.84	7.9	8.3	2.3	2.1	3.3	0.0055	38
IE2-KPER 112 MV2	KPER 112 MV2 IE2	5.5	18.11	2900	IE2- 87.0	88.7	88.8	0.88	10.3	7.8	2.0	1.9	2.7	0.0068	46
IE2-KPER 132 S2T	KPER 132 S2T IE2	5.5	18.1	2900	IE2- 87.0	88.7	88.8	0.88	10.3	7.8	2.0	1.9	2.7	0.0068	48
IE2-KPER 132 S2	KPER 132 S2 IE2	5.5	17.96	2935	IE2- 87.0	87.5	85.1	0.8	11.2	9.1	2.8	2.2	4.0	0.011	57
IE2-WE1R 132 SX2	K11R 132 SX2 E1 IE2	7.5	24.5	2925	IE2- 88.8	89.2	88.3	0.91	13.5	6.7	2.1	1.6	2.9	0.0168	75
IE2-WE1R 160 M2	K11R 160 M2 E1 IE2	11	35.6	2950	IE2- 90.3	90.3	89.1	0.9	19.5	7.7	2.3	1.7	3.1	0.0258	125
IE2-WE1R 160 MX2	K11R 160 MX2 E1 IE2	15	48.7	2940	IE2- 90.7	90.5	89.1	0.92	26	6.7	1.8	1.4	2.6	0.0675	140
IE2-WE1R 160 L2	K11R 160 L2 E1 IE2	18.5	60.2	2935	IE2- 91.0	91.4	91.4	0.91	32	7.2	2.0	1.5	2.8	0.0675	140
IE2-WE1R 180 M2	K11R 180 M2 E1 IE2	22	72	2935	IE2- 91.3	90.6	86.4	0.9	38.5	6.2	1.4	1.1	2.4	0.105	173
IE2-WE1R 200 L2	K11R 200 L2 E1 IE2	30	97	2945	IE2- 92.0	91.3	90.5	0.91	52	6.9	1.7	1.3	2.6	0.128	210
IE2-WE1R 200 LX2	K11R 200 LX2 E1 IE2	37	120	2940	IE2- 92.5	92.3	91.6	0.92	63	7.4	1.9	1.4	2.9	0.154	233
IE2-WE2R 200 LX2	K11R 200 LX2 E2 IE2	37	120	2955	IE2- 92.9	93.2	92.5	0.9	64	8.1	2.3	1.8	3.3	0.154	238
IE2-WE1R 225 M2	K11R 225 M2 E1 IE2	45	146	2950	IE2- 92.9	92.2	91.2	0.87	80.5	6.9	1.7	1.1	2.7	0.220	295
IE2-WE1R 250 M2	K11R 250 M2 E1 IE2	55	178	2955	IE2- 93.5	93.7	93.2	0.89	95.5	8.2	2.3	1.9	2.8	0.375	385
IE2-WE1R 280 S2	K11R 280 S2 E1 IE2	75	241	2970	IE2- 94.1	94.0	91.5	0.9	128	7.9	2.1	1.7	3.0	0.65	500
IE2-WE1R 280 M2	K11R 280 M2 E1 IE2	90	289	2970	IE2- 94.4	94.1	91.9	0.91	151	7.7	2.0	1.7	2.8	0.68	550
IE2-WE1R 315 S2	K11R 315 S2 E1 IE2	110	353	2975	IE2- 94.5	94.3	93.3	0.89	189	8.0	1.3	1.2	2.4	1.21	730
IE2-WE1R 315 M2	K11R 315 M2 E1 IE2	132	424	2975	IE2- 95.0	94.8	94.5	0.89	225	9.2	1.4	1.2	2.4	1.44	820
IE2-WE1R 315 MX2	K11R 315 MX2 E1 IE2	160	514	2973	IE2- 94.8	94.8	94.8	0.89	274	8.2	1.3	1.3	2.4	1.76	955
IE2-WE1R 315 MY2	K11R 315 MY2 E1 IE2	200	640	2983	IE2- 95.4	95.0	94.3	0.88	344	9.4	2.8	2.0	3.0	2.82	1200
IE2-WE1R 315 L2	K11R 315 L2 E1 IE2	250	800	2984	IE2- 95.4	95.4	95.4	0.92	411	9.0	2.3	1.2	2.3	3.66	1450
IE2-WE1R 315 LX2	K11R 315 LX2 E1 IE2	315	1008	2985	IE2- 95.4	95.4	95.0	0.92	518	8.5	2.8	1.6	2.5	4.43	1700
IE2-WE2R 355 M2	W22R 355 M2 E1 IE2	355	1136	2985	IE2- 95.5	95.5	95.5	0.92	583	7.7	1.3	1.0	2.6	4.20	2000
IE2-WE2R 355 MX2	W22R 355 MX2 E1 IE2	400	1278	2990	IE2- 95.5	95.5	95.5	0.91	664	9.4	1.8	1.0	3.0	4.50	2200
IE2-WE2R 355 LY2	W22R 355 LY2 E1 IE2	450	1440	2985	IE2- 95.5	95.5	95.5	0.92	739	7.0	1.3	0.9	2.4	7.10	2400
IE2-WE2R 355 L2	W22R 355 L2 E1 IE2	500	1597	2990	IE2- 95.5	95.5	95.5	0.92	821	8.5	1.5	1.2	2.5	7.10	2400

Three-phase motors with squirrel-cage rotor for marine use, High Efficiency IE2

with surface cooling, duty type S1, continuous duty
for rated voltage, thermal class 155 (F), degree of protection IP 55, 50 Hz

Motor selection data													Design point 400 V, 50 Hz		
Type	Type	P_B	M_B	n_B	η_B			$\cos\varphi_B$	I_B	I_A/I_B	M_A/M_B	M_S/M_B	M_K/M_B	J	m
GL	DNV, RS, LR				(EN 60034-2-1)				400 V						
DNV-GL	BV, ABS, CCS														
RS (KP.. only)		kW	Nm	rpm	100%	75%	50%	-	A	-	-	-	-	kgm ²	kg
Synchronous 1500 rpm – 4-pole version															
IE2-KPR 63 K4	KPR 63 K4 IE2	0.12	0.82	1400	IE2- 59.1	69.1	63.9	0.71	0.35	3.8	2	1.9	2.3	0.0004	6.3
IE2-KPR 63 G4	KPR 63 G4 IE2	0.18	1.21	1425	IE2- 64.7	66.6	60.7	0.64	0.57	4.4	1.8	1.8	2.7	0.0005	7.1
IE2-KPR 71 K4	KPR 71 K4 IE2	0.25	1.67	1430	IE2- 68.5	76.6	73	0.71	0.66	5.6	2.5	2.3	2.9	0.00087	9.9
IE2-KPR 71 G4	KPR 71 G4 IE2	0.37	2.47	1430	IE2- 72.7	78.2	73.1	0.69	0.98	6.2	2.8	2.6	3.2	0.00107	11
IE2-KPR 80 K4	KPR 80 K4 IE2	0.55	3.67	1430	IE2- 77.1	79.6	78.7	0.8	1.25	6	2.4	2.3	2.7	0.00207	14.5
IE2-KPR 80 G4	KPR 80 G4 IE2	0.75	5.01	1430	IE2- 79.6	81.4	79.6	0.81	1.65	7.0	2.9	2.8	3.2	0.0026	17
IE2-KPR 90 S4	KPR 90 S4 IE2	1.1	7.32	1435	IE2- 81.4	82.3	80.4	0.8	2.42	6.8	2.4	2.2	2.9	0.004	23
IE2-KPR 90 L4	KPR 90 L4 IE2	1.5	9.91	1445	IE2- 82.8	83.2	80.7	0.77	3.35	7.2	3.2	3.0	3.5	0.0045	28
IE2-KPR 100 L4	KPR 100 L4 IE2	2.2	14.4	1455	IE2- 84.3	85.2	81.7	0.77	4.8	9.3	3.2	3.0	3.6	0.009	36
IE2-KPR 100 LX4	KPR 100 LX4 IE2	3	19.7	1455	IE2- 85.5	86.3	84.5	0.77	6.5	9.0	3.3	3.1	3.9	0.011	45
IE2-KPER 112 MZ4	KPER 112 MZ4 IE2	4	26.4	1445	IE2- 86.6	87.0	85.0	0.8	8.3	8.2	2.8	2.6	3.6	0.013	50
IE2-KPR 112 M4	KPR 112 M4 IE2	4.00	26.2	1460	IE2- 86.6	87.9	86.2	0.86	7.6	8.7	2.6	2.4	4.1	0.017	56
IE2-KPER 132 S4	KPER 132 S4 IE2	5.50	35.9	1465	IE2- 87.7	87.2	84.8	0.79	11.3	9.3	3	2.8	4.9	0.02	64
IE2-WE1R 132 S4	K11R 132 S4 E1 IE2	5.5	35.7	1470	IE2- 89.8	89.9	88.4	0.87	10	7.4	2.3	1.9	3.4	0.035	87
IE2-WE1R 132 M4	K11R 132 M4 E1 IE2	7.5	48.7	1470	IE2- 89.9	90.0	88.5	0.82	14.5	8.5	2.6	2.1	4.0	0.035	88
IE2-WE1R 160 M4	K11R 160 M4 E1 IE2	11	71	1475	IE2- 90.6	90.3	88.5	0.82	21.5	8.1	3.1	2.4	3.4	0.078	122
IE2-WE2R 160 M4	K11R 160 M4 E2 IE2	11	71	1470	IE2- 90.3	90.3	88.9	0.78	22.5	7.8	2.4	2.1	3.9	0.043	105
IE2-WE1R 160 L4	K11R 160 L4 E1 IE2	15	97	1480	IE2- 92.0	92.0	90.6	0.84	28	9.1	3.0	2.5	3.9	0.115	160
IE2-WE2R 160 L4	K11R 160 L4 E2 IE2	15	97	1480	IE2- 92.0	92.0	90.6	0.84	28	9.1	3.0	2.5	3.9	0.115	161
IE2-WE1R 180 M4	K11R 180 M4 E1 IE2	18.5	120	1475	IE2- 91.5	91.5	90.4	0.86	34	6.8	1.8	1.5	2.7	0.168	207
IE2-WE2R 180 M4	K11R 180 M4 E2 IE2	18.5	120	1470	IE2- 91.2	90.6	89.3	0.78	37.5	6.4	2.0	1.6	2.8	0.138	176
IE2-WE1R 180 L4	K11R 180 L4 E1 IE2	22	142	1475	IE2- 91.6	91.4	89.9	0.83	42	7.3	2.1	1.7	3.0	0.168	215
IE2-WE1R 200 L4	K11R 200 L4 E1 IE2	30	194	1480	IE2- 92.3	91.3	88.2	0.80	58.5	7.3	2.1	1.7	2.9	0.275	277
IE2-WE1R 225 S4	K11R 225 S4 E1 IE2	37	240	1475	IE2- 92.7	91.8	90.7	0.84	68.5	7.4	2.2	1.7	2.7	0.313	313
IE2-WE1R 225 M4	K11R 225 M4 E1 IE2	45	290	1483	IE2- 93.1	93.0	91.1	0.84	83	7.9	2.3	1.9	2.4	0.525	390
IE2-WE2R 225 M4	K11R 225 M4 E2 IE2	45	291	1475	IE2- 93.1	92.9	92.1	0.80	87	7.6	2.6	1.9	3.1	0.356	346
IE2-WE1R 250 M4	K11R 250 M4 E1 IE2	55	354	1485	IE2- 94.0	94.1	92.5	0.84	101	8.0	2.0	1.7	2.3	0.95	535
IE2-WE2R 250 M4	K11R 250 M4 E2 IE2	55	356	1477	IE2- 93.9	93.8	93.7	0.82	103	7.5	2.4	1.9	2.4	0.62	435
IE2-WE1R 280 S4	K11R 280 S4 E1 IE2	75	482	1485	IE2- 94.2	94.4	92.1	0.84	137	7.2	1.8	1.6	2.1	0.95	550
IE2-WE1R 280 M4	K11R 280 M4 E1 IE2	90	580	1483	IE2- 94.3	94.5	94.0	0.84	164	7.6	1.8	1.6	2.3	1.10	610
IE2-WE1R 315 S4	K11R 315 S4 E1 IE2	110	707	1485	IE2- 94.8	94.8	94.0	0.82	204	8.5	1.8	1.5	2.7	1.96	760
IE2-WE1R 315 M4	K11R 315 M4 E1 IE2	132	849	1484	IE2- 95.0	95.0	94.5	0.83	242	8.2	1.8	1.6	2.3	2.27	850
IE2-WE1R 315 MX4	K11R 315 MX4 E1 IE2	160	1031	1482	IE2- 95.0	95.0	94.5	0.84	289	7.4	1.6	1.4	2.2	2.73	975
IE2-WE1R 315 MY4	K11R 315 MY4 E1 IE2	200	1282	1490	IE2- 95.1	95.1	94.5	0.87	349	8.5	1.8	1.6	2.5	4.82	1270
IE2-WE1R 315 L4	K11R 315 L4 E1 IE2	250	1602	1490	IE2- 95.4	95.4	95.3	0.88	430	9.0	2.2	1.5	2.7	5.93	1450
IE2-WE1R 315 LX4	K11R 315 LX4 E1 IE2	315	2019	1490	IE2- 95.4	95.4	95.0	0.88	542	9.0	2.4	1.6	2.6	6.82	1630
IE2-WE2R 355 M4	W22R 355 M4 E1 IE2	355	2271	1493	IE2- 95.5	95.5	95.0	0.87	617	8.0	1.3	1.0	2.7	7.90	2150
IE2-WE2R 355 MX4	W22R 355 MX4 E1 IE2	400	2557	1494	IE2- 95.5	95.5	95.5	0.88	687	8.5	1.3	1.0	3.0	9.50	2400
IE2-WE2R 355 LY4	W22R 355 LY4 E1 IE2	450	2873	1496	IE2- 95.5	95.5	95.5	0.86	791	8.5	1.4	0.8	2.9	10.00	2500
IE2-WE2R 355 L4	W22R 355 L4 E1 IE2	500	3198	1493	IE2- 95.5	95.5	95.5	0.84	900	8.0	1.2	0.9	3.0	10.00	2500

Three-phase motors with squirrel-cage rotor for marine use, High Efficiency IE2

with surface cooling, duty type S1, continuous duty
for rated voltage, thermal class 155 (F), degree of protection IP 55, 50 Hz

Motor selection data													Design point 400 V, 50 Hz			
Type	Type	P _B	M _B	n _B	η _B			cosφ _B	I _B	I _A /I _B	M _A /M _B	M _S /M _B	M _K /M _B	J	m	
GL	DNV, RS, LR				(EN 60034-2-1)				400 V							
DNV-GL	BV, ABS, CCS															
RS (KP.. only)		kW	Nm	rpm	100 %	75 %	50 %	-	A	-	-	-	-	kgm ²	kg	
Synchronous 1000 rpm – 6-pole version																
IE2-KPR 71 K6	KPR 71 K6 IE2	0.18	1.85	930	IE2- 56.6	65.0	59.4	0.68	0.57	3.4	2.0	2.0	2.2	0.0013	11	
IE2-KPR 71 G6	KPR 71 G6 IE2	0.25	2.55	935	IE2- 61.6	69.9	65.0	0.67	0.75	3.9	2.3	2.3	2.5	0.00175	12.5	
IE2-KPR 80 K6	KPR 80 K6 IE2	0.37	3.72	950	IE2- 67.6	73.5	69.7	0.70	1.03	4.0	1.9	1.9	2.4	0.00325	15	
IE2-KPR 80 G6	KPR 80 G6 IE2	0.55	5.53	950	IE2- 73.1	75.9	72.4	0.69	1.50	4.1	2.1	2.1	2.5	0.00425	18	
IE2-KPR 90 S6	KPR 90 S6 IE2	0.75	7.5	955	IE2- 75.9	78.3	75.1	0.71	1.95	4.9	2.4	2.3	2.6	0.00625	24	
IE2-KPR 90 L6	KPR 90 L6 IE2	1.1	11	955	IE2- 78.1	82.0	79.3	0.71	2.75	5.4	2.5	2.4	2.8	0.0072	30	
IE2-KPR 100 LX6	KPR 100 LX6 IE2	1.5	15	955	IE2- 79.8	83.5	81.5	0.76	3.45	5.9	2.3	2.2	2.8	0.0139	36	
IE2-KPER 112 MV6	KPER 112 MV6 IE2	2.2	22	955	IE2- 81.8	82.5	79.8	0.75	5.15	5.7	2.4	2.3	2.9	0.0155	48	
IE2-KPER 112 MZ6	KPER 112 MZ6 IE2	3	30	955	IE2- 83.3	83.1	80.5	0.75	6.85	6.5	2.8	2.7	3.5	0.043	50	
IE2-KPER 132 SX6T	KPER 132 SX6T IE2	3	30.0	955	IE2- 83.3	83.1	80.5	0.73	7.1	7.0	3.2	3.1	4.0	0.0165	52	
IE2-KPER 132 S6	KPER 132 S6 IE2	3	29.7	965	IE2- 84.9	84.4	82.0	0.77	6.7	6.8	2.5	2.4	3.7	0.023	55	
IE2-KPER 132 M6	KPER 132 M6 IE2	4	39.6	965	IE2- 84.6	85.5	83.6	0.78	8.8	6.8	2.4	2.4	3.6	0.029	66	
IE2-WE1R 132 M6	K11R 132 M6 E1 IE2	4	39.6	965	IE2- 85.5	85.5	83.8	0.79	8.5	5.1	1.8	1.6	2.4	0.043	76	
IE2-WE1R 132 MX6	K11R 132 MX6 E1 IE2	5.5	54	970	IE2- 86.1	85.5	82.4	0.77	12	5.7	2.2	1.7	2.7	0.053	85	
IE2-WE1R 160 M6	K11R 160 M6 E1 IE2	7.5	73	975	IE2- 87.4	88.1	86.0	0.81	15.5	6.3	2.5	2.1	2.9	0.113	118	
IE2-WE2R 160 M6	K11R 160 M6 E2 IE2	7.5	74	970	IE2- 87.5	87.6	85.9	0.79	15.5	5.9	2.1	1.8	2.9	0.053	103	
IE2-WE1R 160 L6	K11R 160 L6 E1 IE2	11	108	970	IE2- 88.7	87.9	86.3	0.85	21	5.8	2.2	1.9	2.7	0.145	135	
IE2-WE2R 160 L6	K11R 160 L6 E2 IE2	11	108	975	IE2- 88.9	88.8	87.0	0.81	22	6.8	2.7	2.4	3.1	0.166	155	
IE2-WE1R 180 L6	K11R 180 L6 E1 IE2	15	147	975	IE2- 89.7	88.8	86.7	0.84	28.5	6.2	2.1	1.8	2.8	0.228	185	
IE2-WE2R 180 L6	K11R 180 L6 E2 IE2	15	148	970	IE2- 89.7	88.8	87.8	0.83	29	5.6	2.3	1.7	2.6	0.166	157	
IE2-WE1R 200 L6	K11R 200 L6 E1 IE2	18.5	180	980	IE2- 90.4	88.8	86.5	0.85	35	6.6	2.3	1.7	2.9	0.268	208	
IE2-WE1R 200 LX6	K11R 200 LX6 E1 IE2	22	214	980	IE2- 90.9	90.2	88.5	0.86	40.5	6.4	2.2	1.8	2.7	0.443	272	
IE2-WE2R 200 LX6	K11R 200 LX6 E2 IE2	22	215	975	IE2- 90.9	89.9	88.5	0.84	41.5	6.7	2.4	2.0	3.0	0.324	238	
IE2-WE1R 225 M6	K11R 225 M6 E1 IE2	30	291	985	IE2- 92.0	91.5	90.0	0.86	54.5	7.3	2.5	2.2	2.9	0.825	365	
IE2-WE2R 225 M6	K11R 225 M6 E2 IE2	30	291	985	IE2- 92.0	91.5	90.0	0.86	54.5	7.3	2.5	2.2	2.9	0.825	365	
IE2-WE1R 250 M6	K11R 250 M6 E1 IE2	37	359	985	IE2- 92.2	91.7	90.7	0.85	68	6.4	2.7	1.8	2.4	1.28	480	
IE2-WE2R 250 M6	K11R 250 M6 E2 IE2	37	359	985	IE2- 92.2	91.7	90.7	0.85	68	6.4	2.7	1.8	2.4	1.28	480	
IE2-WE1R 280 S6	K11R 280 S6 E1 IE2	45	437	983	IE2- 93.0	92.7	92.4	0.87	80.5	6.5	2.2	1.7	2.4	1.48	560	
IE2-WE1R 280 M6	K11R 280 M6 E1 IE2	55	531	990	IE2- 93.5	93.5	93.0	0.85	100	7.6	2.0	1.5	2.5	2.63	710	
IE2-WE1R 315 S6	K11R 315 S6 E1 IE2	75	723	990	IE2- 93.9	93.7	93.5	0.87	133	7.8	1.9	1.5	2.5	3.33	804	
IE2-WE1R 315 M6	K11R 315 M6 E1 IE2	90	868	990	IE2- 94.0	94.0	93.5	0.88	157	7.5	1.8	1.5	2.5	3.60	865	
IE2-WE1R 315 MX6	K11R 315 MX6 E1 IE2	110	1061	990	IE2- 94.3	94.3	94.0	0.87	194	7.5	1.8	1.4	2.3	6.67	1210	
IE2-WE1R 315 MY6	K11R 315 MY6 E1 IE2	132	1273	990	IE2- 94.6	94.3	94.0	0.87	231	7.5	1.9	1.4	2.2	6.67	1250	
IE2-WE1R 315 L6	K11R 315 L6 E1 IE2	160	1543	990	IE2- 94.8	94.5	93.5	0.88	277	7.5	2.0	1.5	2.4	8.60	1430	
IE2-WE1R 315 LX6	K11R 315 LX6 E1 IE2	200	1929	990	IE2- 95.0	95.0	94.5	0.86	353	7.0	1.9	1.5	2.2	8.60	1460	
IE2-WE2R 355 M6	W22R 355 M6 E1 IE2	250	2402	994	IE2- 95.0	95.0	94.7	0.84	452	7.0	1.5	1.2	2.2	8.20	1850	
IE2-WE2R 355 MX6	W22R 355 MX6 E1 IE2	315	3023	995	IE2- 95.2	95.2	95.2	0.86	555	7.0	1.3	1.1	2.2	12.10	2200	
IE2-WE2R 355 LY6	W22R 355 LY6 E1 IE2	355	3407	995	IE2- 95.0	95.0	94.0	0.77	700	7.5	1.8	1.5	2.6	14.00	2400	

Three-phase motors with squirrel-cage rotor for marine use, High Efficiency IE2

with surface cooling, duty type S1, continuous duty
for rated voltage, thermal class 155 (F), degree of protection IP 55, 50 Hz

Motor selection data													Design point 400 V, 50 Hz		
Type	Type	P_B	M_B	n_B	η_B			$\cos\varphi_B$	I_B	I_A/I_B	M_A/M_B	M_S/M_B	M_K/M_B	J	m
GL	DNV, RS, LR				(EN 60034-2-1)				400 V						
DNV-GL	BV, ABS, CCS														
RS (KP.. only)		kW	Nm	rpm	100%	75%	50%	-	A	-	-	-	-	kgm ²	kg
Synchronous 750 rpm – 8-pole version															
IE2-KPER 80 G8	KPER 80 G8 IE2	0.25	3.43	695	IE2- 50.6	50.4	42.5	0.56	1.12	3.0	2.3	2.3	2.5	0.00175	12
IE2-KPR 90 S8	KPR 90 S8 IE2	0.37	4.98	710	IE2- 56.1	70.3	65.7	0.63	1.20	3.6	2.1	2.1	2.3	0.00625	24
IE2-KPR 90 L8	KPR 90 L8 IE2	0.55	7.5	700	IE2- 61.7	70.6	66.3	0.64	1.72	3.6	1.8	1.8	2.3	0.0072	26
IE2-KPR 100 L8	KPR 100 L8 IE2	0.75	10.02	715	IE2- 66.2	75.9	71.3	0.63	2.25	4.4	2.5	2.5	2.8	0.0123	33.5
IE2-KPR 100 LX8	KPR 100 LX8 IE2	1.1	14.8	710	IE2- 70.8	78.0	74.2	0.63	3.20	4.2	1.9	1.8	2.5	0.0139	36
IE2-KPER 112 MV8	KPER 112 MV8 IE2	1.5	20.46	700	IE2- 74.1	78.7	76.0	0.65	4.25	3.8	1.6	1.6	2.1	0.0155	48
IE2-KPER 132 S8	KPER 132 S8 IE2	2.2	29.2	720	IE2- 77.6	81.0	77.8	0.67	5.75	5.3	2.3	2.2	3.2	0.023	55
IE2-KPER 132 M8	KPER 132 M8 IE2	3	39.8	720	IE2- 80.0	82.0	79.1	0.67	7.90	5.2	2.3	2.1	3.2	0.029	65
IE2-WE1R 132 M8	K11R 132 M8 E1 IE2	3	39.8	720	IE2- 82.7	83.0	81.3	0.74	7.1	3.9	1.6	1.3	1.9	0.0430	74
IE2-WE1R 160 M8	K11R 160 M8 E1 IE2	4	53.2	718	IE2- 84.2	83.7	81.9	0.724	9.5	4.6	1.6	0.0	2.5	0.0530	86
IE2-WE1R 160 MX8	K11R 160 MX8 E1 IE2	5.5	72	730	IE2- 86.9	86.6	84.1	0.72	12.5	4.8	2.1	1.8	2.6	0.1130	115
IE2-WE2R 160 MX8	K11R 160 MX8 E2 IE2	5.5	73	715	IE2- 83.9	84.0	81.9	0.71	13.5	4.3	1.7	1.5	2.5	0.0530	103
IE2-WE1R 160 L8	K11R 160 L8 E1 IE2	7.5	99	725	IE2- 86.9	87.6	86.6	0.76	16.5	4.5	1.8	1.6	2.3	0.1450	136
IE2-WE1R 180 L8	K11R 180 L8 E1 IE2	11	144	727	IE2- 88.2	88.2	86.7	0.78	23	4.9	1.8	1.6	2.4	0.2280	175
IE2-WE2R 180 L8	K11R 180 L8 E2 IE2	11	144	730	IE2- 87.9	87.4	85.2	0.67	25.5	4.3	1.9	1.6	2.3	0.1660	157
IE2-WE1R 200 L8	K11R 200 L8 E1 IE2	15	197	727	IE2- 88.2	88.1	86.4	0.77	32	4.9	1.9	1.7	2.3	0.2680	200
IE2-WE1R 225 S8	K11R 225 S8 E1 IE2	18.5	242	730	IE2- 89.6	89.4	87.2	0.78	38	5.4	2.1	2.0	2.8	0.44	265
IE2-WE2R 225 S8	K11R 225 S8 E2 IE2	18.5	240	735	IE2- 90.7	90.7	89.4	0.8	37	6.1	2.1	1.9	2.9	0.51	305
IE2-WE1R 225 M8	K11R 225 M8 E1 IE2	22	287	733	IE2- 90.6	89.4	89.9	0.78	45	5.6	2.2	1.8	2.6	0.83	380
IE2-WE2R 225 M8	K11R 225 M8 E2 IE2	22	286	735	IE2- 90.3	90.3	88.7	0.77	45.5	6.1	2.2	2.0	2.9	0.51	307
IE2-WE1R 250 M8	K11R 250 M8 E1 IE2	30	391	732	IE2- 90.8	91.0	90.0	0.78	61.0	5.6	2.2	1.9	2.4	0.83	380
IE2-WE1R 280 S8	K11R 280 S8 E1 IE2	37	479	737	IE2- 90.8	91.3	90.7	0.80	73.5	4.9	1.9	1.5	2.0	1.35	480
IE2-WE1R 280 M8	K11R 280 M8 E1 IE2	45	581	740	IE2- 91.8	91.8	90.7	0.77	92.0	5.8	2.3	1.8	2.5	1.55	535
IE2-WE1R 315 S8	K11R 315 S8 E1 IE2	55	710	740	IE2- 92.2	92.2	92.1	0.80	108	6.3	1.8	1.5	2.3	2.63	715
IE2-WE1R 315 M8	K11R 315 M8 E1 IE2	75	968	740	IE2- 92.7	92.5	92.5	0.81	143	6.0	2.1	1.4	2.1	3.33	805
IE2-WE1R 315 MX8	K11R 315 MX8 E1 IE2	90	1161	740	IE2- 93.0	93.0	93.0	0.79	177	6.5	1.7	1.5	2.2	3.60	850
IE2-WE1R 315 MY8	K11R 315 MY8 E1 IE2	110	1420	740	IE2- 93.4	93.4	93.4	0.82	207	6.5	1.8	1.6	2.2	6.00	1080
IE2-WE1R 315 L8	K11R 315 L8 E1 IE2	132	1704	740	IE2- 93.2	93.2	93.2	0.83	246	6.0	1.5	1.4	2.2	6.76	1250
IE2-WE1R 315 LX8	K11R 315 LX8 E1 IE2	160	2065	740	IE2- 93.9	93.9	93.8	0.80	307	7.2	2.2	1.8	2.5	8.71	1430
IE2-WE2R 355 M8	W22R 355 M8 E1 IE2	200	2571	743	IE2- 94.5	94.1	91.5	0.77	397	0.0	0.0	0.0	0.0	9.50	1850
IE2-WE2R 355 MX8	W22R 355 MX8 E1 IE2	250	3205	745	IE2- 94.0	94.0	94.0	0.83	463	7.0	1.2	1.0	2.6	13.40	2200
IE2-WE2R 355 LY8	W22R 355 LY8 E1 IE2	280	3599	743	IE2- 94.3	94.3	94.3	0.78	549	7.2	1.3	1.0	2.7	15.80	2400

Three-phase motors with squirrel-cage rotor for marine use, High Efficiency IE2

with surface cooling, duty type S1, continuous duty
for rated voltage, thermal class 155 (F), degree of protection IP 55, 60 Hz

Motor selection data													Design point 460 V, 60 Hz		
Type	Type	P _B	M _B	n _B	η _B			cosφ _B	I _B	I _A /I _B	M _A /M _B	M _S /M _B	M _K /M _B	J	m
GL	DNV, RS, LR				(EN 60034-2-1)				460 V						
DNV-GL	BV, ABS, CCS														
RS (KP.. only)		kW	Nm	rpm	100%	75%	50%	-	A	-	-	-	-	kgm ²	kg
Synchronous 3600 rpm – 2-pole version															
IE2-KPR 56 G2	KPR 56 G2 IE2	0.14	0.39	3410	IE2- 59.5	70.2	66.5	0.82	0.3	5.2	2	2	2.3	0.00015	4.8
IE2-KPR 63 K2	KPR 63 K2 IE2	0.21	0.58	3430	IE2- 64	68.6	63.1	0.83	0.44	5.5	2.6	2.5	3.1	0.00025	6.3
IE2-KPR 63 G2	KPR 63 G2 IE2	0.3	0.83	3440	IE2- 68	73.8	69.8	0.87	0.57	6.1	2.7	2.5	3.2	0.00032	7
IE2-KPR 71 K2	KPR 71 K2 IE2	0.44	1.21	3460	IE2- 72	83.9	82.4	0.86	0.78	7.3	3	2.8	3.2	0.00057	10
IE2-KPR 71 G2	KPR 71 G2 IE2	0.65	1.79	3465	IE2- 75.5	82	81.6	0.87	1.13	7.8	2.8	2.5	2.9	0.00072	11.2
IE2-KPR 80 K2	KPR 80 K2 IE2	0.75	2.05	3500	IE2- 75.5	83.5	80.6	0.87	1.3	8.5	2.5	2.1	3	0.00132	15
IE2-KPR 80 G2	KPR 80 G2 IE2	1.1	3.01	3490	IE2- 82.5	83.3	77.7	0.88	1.9	9.2	3	2.7	3.3	0.0017	18
IE2-KPR 90 S2	KPR 90 S2 IE2	1.5	4.06	3530	IE2- 84	85.6	83	0.85	2.54	9.2	2.6	2.4	3.5	0.00275	23.5
IE2-KPR 90 L2	KPR 90 L2 IE2	2.2	6	3500	IE2- 85.5	85.9	83	0.86	3.7	8.4	2.4	2.1	3.1	0.00275	23.5
IE2-KPR 100 L2	KPR 100 L2 IE2	3	8.09	3540	IE2- 87.5	86.2	82.5	0.74	5.8	8.4	2.2	1.9	3.8	0.0045	31
IE2-KPER 112 MX2	KPER 112 MX2 IE2	4	10.82	3530	IE2- 87.5	89.1	88.4	0.83	6.8	7.1	1.6	1.4	2.6	0.0055	38
IE2-KPER 112 MV2	KPER 112 MV2 IE2	5.5	14.96	3510	IE2- 88.5	89.3	88.9	0.87	8.85	9.2	2.1	2	3.1	0.0068	46
IE2-KPER 132 S2T	KPER 132 S2T IE2	5.5	14.96	3510	IE2- 88.5	89.3	88.9	0.87	8.85	9.2	2.1	2	3.1	0.0068	48
IE2-KPER 132 S2	KPER 132 S2 IE2	6.6	17.86	3530	IE2- 89.5	89.7	87.9	0.83	11.1	8.9	2.4	1.8	3.7	0.011	57
IE2-WE1R 132 SX2	K11R 132 SX2 E1 IE2	9.0	24.5	3505	IE2- 89.5	89.4	88.5	0.90	14.0	6.2	2.1	1.7	2.8	0.0168	75
IE2-WE1R 160 M2	K11R 160 M2 E1 IE2	13.0	35.0	3550	IE2- 91.0	90.9	89.5	0.91	20.0	7.3	2.0	1.6	2.7	0.0258	125
IE2-WE1R 160 MX2	K11R 160 MX2 E1 IE2	16.5	44.6	3535	IE2- 90.2	89.7	88.4	0.91	25.0	6.5	1.9	1.4	2.6	0.0675	140
IE2-WE1R 160 L2	K11R 160 L2 E1 IE2	22.0	59.6	3525	IE2- 91.6	91.3	89.6	0.92	37.5	7.0	1.8	1.3	2.6	0.0675	140
IE2-WE1R 180 M2	K11R 180 M2 E1 IE2	26	70	3545	IE2- 91.7	91.6	90.9	0.90	39.5	6.0	1.5	1.2	2.4	0.105	173
IE2-WE1R 200 L2	K11R 200 L2 E1 IE2	36	97	3550	IE2- 92.4	92.5	91.6	0.91	54.0	6.0	1.4	1.1	2.3	0.128	210
IE2-WE1R 200 LX2	K11R 200 LX2 E1 IE2	44	119	3545	IE2- 93.0	92.4	92.1	0.91	65.5	6.8	1.9	1.5	2.8	0.154	233
IE2-WE2R 200 LX2	K11R 200 LX2 E2 IE2	44	119	3545	IE2- 93.0	92.4	92.1	0.91	65.5	6.8	1.9	1.5	2.8	0.154	238
IE2-WE1R 225 M2	K11R 225 M2 E1 IE2	54	145	3545	IE2- 93.0	92.5	91.8	0.88	83.0	6.9	1.7	1.4	2.8	0.220	295
IE2-WE1R 250 M2	K11R 250 M2 E1 IE2	66	178	3550	IE2- 93.6	93.7	93.0	0.90	98.5	7.6	2.1	1.8	2.7	0.375	385
IE2-WE1R 280 S2	K11R 280 S2 E1 IE2	90	241	3570	IE2- 94.5	93.9	92.8	0.91	131	7.3	1.9	1.6	2.8	0.65	500
IE2-WE1R 280 M2	K11R 280 M2 E1 IE2	110	294	3568	IE2- 94.5	94.0	93.7	0.91	161	7.5	1.9	1.6	2.7	0.68	550
IE2-WE1R 315 S2	K11R 315 S2 E1 IE2	120	320	3580	IE2- 94.5	94.0	93.0	0.89	179	8.5	1.4	1.3	2.5	1.21	730
IE2-WE1R 315 M2	K11R 315 M2 E1 IE2	145	387	3580	IE2- 95.0	94.5	94.0	0.90	213	9.4	1.4	1.2	2.4	1.44	820
IE2-WE1R 315 MX2	K11R 315 MX2 E1 IE2	175	467	3575	IE2- 95.4	95.0	94.0	0.90	256	8.2	1.7	1.6	2.7	1.76	955
IE2-WE1R 315 MY2	K11R 315 MY2 E1 IE2	220	586	3585	IE2- 95.4	95.0	94.0	0.89	325	9.5	2.8	2.0	3.0	2.82	1200
IE2-WE1R 315 L2	K11R 315 L2 E1 IE2	280	748	3580	IE2- 95.5	95.5	95.5	0.92	400	8.0	2.3	1.4	2.3	3.66	1450
IE2-WE1R 315 LX2	K11R 315 LX2 E1 IE2	330	879	3585	IE2- 95.4	95.4	95.4	0.92	472	9.0	2.8	1.6	2.5	4.43	1700
IE2-WE2R 355 M2	W22R 355 M2 E1 IE2	375	999	3585	IE2- 95.4	95.0	94.5	0.91	542	8.5	1.5	1.3	2.2	4.20	2000
IE2-WE2R 355 MX2	W22R 355 MX2 E1 IE2	440	1170	3590	IE2- 95.8	95.5	95.0	0.91	633	9.4	1.7	1.1	3.0	4.50	2200
IE2-WE2R 355 LY2	W22R 355 LY2 E1 IE2	490	1303	3590	IE2- 95.5	95.5	95.0	0.92	700	7.5	1.5	0.9	2.4	7.10	2400
IE2-WE2R 355 L2	W22R 355 L2 E1 IE2	550	1467	3580	IE2- 95.5	95.5	95.0	0.92	786	8.5	1.5	1.0	2.4	7.10	2400

Three-phase motors with squirrel-cage rotor for marine use, High Efficiency IE2

with surface cooling, duty type S1, continuous duty
for rated voltage, thermal class 155 (F), degree of protection IP 55, 60 Hz

Motor selection data													Design point 460 V, 60 Hz		
Type	Type	P_B	M_B	n_B	η_B			$\cos\varphi_B$	I_B	I_A/I_B	M_A/M_B	M_S/M_B	M_K/M_B	J	m
GL	DNV, RS, LR				(EN 60034-2-1)				460 V						
DNV-GL	BV, ABS, CCS														
RS (KP.. only)		kW	Nm	rpm	100%	75%	50%	-	A	-	-	-	-	kgm ²	kg
Synchronous 1800 rpm – 4-pole version															
IE2-KPR 63 K4	KPR 63 K4 IE2	0.14	0.79	1700	IE2- 64	70.3	65.8	0.71	0.35	4.1	2	1.9	2.4	0.0004	6.3
IE2-KPR 63 G4	KPR 63 G4 IE2	0.21	1.16	1725	IE2- 68	68.8	62.9	0.66	0.56	4.8	2.6	2.6	2.9	0.0005	7.1
IE2-KPR 71 K4	KPR 71 K4 IE2	0.3	1.66	1725	IE2- 70	76.5	72.8	0.74	0.66	5.2	2.1	2	2.7	0.00087	9.9
IE2-KPR 71 G4	KPR 71 G4 IE2	0.44	2.44	1725	IE2- 72	79.6	76	0.72	0.96	6.1	2.5	2.4	3.2	0.00107	11
IE2-KPR 80 K4	KPR 80 K4 IE2	0.65	3.6	1725	IE2- 78	80.5	76.9	0.81	1.24	6.2	2.2	2.1	2.6	0.00207	14.5
IE2-KPR 80 G4	KPR 80 G4 IE2	0.75	4.1	1745	IE2- 82.5	81.7	79.2	0.78	1.46	7.7	3.1	2.9	3.5	0.0026	17
IE2-KPR 90 S4	KPR 90 S4 IE2	1.1	6.02	1745	IE2- 84	84.5	82	0.76	2.15	7.3	3	2.8	3.5	0.004	23
IE2-KPR 90 L4	KPR 90 L4 IE2	1.5	8.19	1750	IE2- 84	82.3	78.6	0.74	3.02	7.9	3.2	3	3.5	0.0045	28
IE2-KPR 100 L4	KPR 100 L4 IE2	2.2	11.9	1765	IE2- 87.5	86.3	82.9	0.71	4.45	8.6	2.6	2.5	3.9	0.009	36
IE2-KPR 100 LX4	KPR 100 LX4 IE2	3	16.3	1760	IE2- 87.5	87.3	84.4	0.74	5.78	8.7	3.2	3	3.8	0.011	45
IE2-KPER 112 MZ4	KPER 112 MZ4 IE2	4	21.8	1750	IE2- 87.5	87.8	85.4	0.76	7.5	8.4	2.8	2.6	3.8	0.013	50
IE2-KPR 112 M4	KPR 112 M4 IE2	4.5	24.6	1745	IE2- 87.5	87.5	85.9	0.8	8.05	7.8	2.4	2.3	3.5	0.013	50
IE2-KPER 132 S4	KPER 132 S4 IE2	6.6	36.1	1745	IE2- 89.5	90.1	89.7	0.88	10.5	7.1	2	1.6	3.2	0.02	64
IE2-WE1R 132 S4	K11R 132 S4 E1 IE2	6.6	35.7	1765	IE2- 89.8	90.0	88.5	0.88	11	6.6	2.2	1.6	3.0	0.035	87
IE2-WE1R 132 M4	K11R 132 M4 E1 IE2	9.0	48.6	1770	IE2- 90.8	90.6	89.0	0.83	15	8.1	2.5	2.0	3.8	0.035	88
IE2-WE1R 160 M4	K11R 160 M4 E1 IE2	13.0	70	1775	IE2- 91.1	90.8	89.2	0.82	22.0	7.7	2.8	2.2	3.2	0.078	122
IE2-WE2R 160 M4	K11R 160 M4 E2 IE2	13	70	1765	IE2- 91.3	91.5	90.4	0.80	22.5	7.5	2.3	1.9	3.6	0.043	105
IE2-WE1R 160 L4	K11R 160 L4 E1 IE2	18.0	97	1770	IE2- 92.5	92.4	91.4	0.86	28.0	8.0	2.5	2.0	3.0	0.115	160
IE2-WE2R 160 L4	K11R 160 L4 E2 IE2	18	97	1775	IE2- 92.5	92.4	91.4	0.85	28.5	8.5	2.7	2.3	3.5	0.115	161
IE2-WE1R 180 M4	K11R 180 M4 E1 IE2	22.0	118	1775	IE2- 92.4	91.4	89.9	0.86	35.0	6.3	1.6	1.4	2.5	0.168	207
IE2-WE2R 180 M4	K11R 180 M4 E2 IE2	22	118	1775	IE2- 92.4	91.5	90.1	0.80	37.5	6.1	1.9	1.5	2.6	0.138	176
IE2-WE1R 180 L4	K11R 180 L4 E1 IE2	26	139	1780	IE2- 93.0	91.7	90.0	0.84	42.0	7.2	2.0	1.7	2.9	0.168	215
IE2-WE1R 200 L4	K11R 200 L4 E1 IE2	36	193	1780	IE2- 93.0	92.5	91.4	0.82	59.5	6.8	2.0	1.7	2.8	0.275	277
IE2-WE1R 225 S4	K11R 225 S4 E1 IE2	44	237	1775	IE2- 93.6	92.9	92.1	0.83	71.5	6.5	1.9	1.6	2.5	0.313	313
IE2-WE1R 225 M4	K11R 225 M4 E1 IE2	49	263	1780	IE2- 93.6	93.0	91.5	0.84	78.0	8.0	2.2	1.8	2.4	0.525	390
IE2-WE2R 225 M4	K11R 225 M4 E2 IE2	45	242	1775	IE2- 93.6	92.7	91.2	0.80	75.5	8.3	2.9	2.1	3.3	0.356	346
IE2-WE1R 250 M4	K11R 250 M4 E1 IE2	64	343	1780	IE2- 94.1	93.5	93.0	0.85	100	7.6	1.7	1.5	2.2	0.95	535
IE2-WE2R 250 M4	K11R 250 M4 E2 IE2	63	339	1777	IE2- 94.1	93.6	93.2	0.83	101	7.2	2.3	1.8	2.3	0.62	435
IE2-WE1R 280 S4	K11R 280 S4 E1 IE2	90	483	1779	IE2- 94.5	94.2	93.9	0.84	142	6.6	1.7	1.4	2.0	0.95	550
IE2-WE1R 280 M4	K11R 280 M4 E1 IE2	105	563	1780	IE2- 95.0	94.6	94.1	0.84	166	7.4	1.8	1.6	2.2	1.10	610
IE2-WE1R 315 S4	K11R 315 S4 E1 IE2	132	707	1784	IE2- 95.2	95.2	94.6	0.85	205	8.0	1.6	1.5	2.2	1.96	760
IE2-WE1R 315 M4	K11R 315 M4 E1 IE2	145	776	1784	IE2- 95.0	95.0	94.5	0.85	225	8.2	1.9	1.7	2.3	2.27	850
IE2-WE1R 315 MX4	K11R 315 MX4 E1 IE2	175	939	1780	IE2- 95.1	95.1	94.5	0.85	272	8.0	1.6	1.5	2.2	2.73	975
IE2-WE1R 315 MY4	K11R 315 MY4 E1 IE2	220	1174	1790	IE2- 95.4	95.4	95.0	0.87	333	8.8	2.0	1.6	2.6	4.82	1270
IE2-WE1R 315 L4	K11R 315 L4 E1 IE2	280	1792	1790	IE2- 95.4	95.4	95.3	0.88	419	8.5	2.2	1.6	2.5	5.93	1450
IE2-WE1R 315 LX4	K11R 315 LX4 E1 IE2	330	1761	1790	IE2- 95.4	94.5	93.5	0.87	499	9.2	2.5	1.7	1.7	6.82	1630
IE2-WE2R 355 M4	W22R 355 M4 E1 IE2	375	1997	1793	IE2- 95.4	95.4	94.5	0.87	567	9.0	1.3	0.9	2.9	7.90	2150
IE2-WE2R 355 MX4	W22R 355 MX4 E1 IE2	425	2267	1790	IE2- 95.8	95.8	95.5	0.87	640	9.0	1.4	1.0	3.1	9.50	2400
IE2-WE2R 355 LY4	W22R 355 LY4 E1 IE2	475	2529	1794	IE2- 95.8	95.8	95.5	0.83	750	9.2	1.5	1.0	3.5	10.00	2500
IE2-WE2R 355 L4	W22R 355 L4 E1 IE2	525	2795	1794	IE2- 95.8	95.8	95.5	0.83	829	9.0	1.3	1.0	3.3	10.00	2500

Three-phase motors with squirrel-cage rotor for marine use, High Efficiency IE2

with surface cooling, duty type S1, continuous duty
for rated voltage, thermal class 155 (F), degree of protection IP 55, 60 Hz

Motor selection data													Design point 460 V, 60 Hz		
Type	Type	P _B	M _B	n _B	η _B			cosφ _B	I _B	I _A /I _B	M _A /M _B	M _S /M _B	M _K /M _B	J	m
GL	DNV, RS, LR				(EN 60034-2-1)				460 V						
DNV-GL	BV, ABS, CCS														
RS (KP.. only)		kW	Nm	rpm	100%	75%	50%	-	A	-	-	-	-	kgm ²	kg
Synchronous 1200 rpm – 6-pole version															
IE2-KPR 71 K6	KPR 71 K6 IE2	0.21	1.78	1125	IE2- 55	68.3	63.5	0.68	0.55	3.6	2.1	2	2.3	0.0013	11
IE2-KPR 71 G6	KPR 71 G6 IE2	0.3	2.55	1125	IE2- 61.6	72.5	67.5	0.7	0.73	4.4	2.2	2.2	2.4	0.00175	12.5
IE2-KPR 80 K6	KPR 80 K6 IE2	0.44	3.67	1145	IE2- 64	75.9	72.2	0.7	1.03	4.1	1.8	1.8	2.3	0.00325	15
IE2-KPR 80 G6	KPR 80 G6 IE2	0.65	5.42	1145	IE2- 73	77.6	74.3	0.69	1.5	4.4	2.1	2.1	2.5	0.00425	18
IE2-KPR 90 S6	KPR 90 S6 IE2	0.75	6.17	1160	IE2- 80	79.6	75.9	0.67	1.76	5.6	2.7	2.6	3.1	0.00625	24
IE2-KPR 90 L6	KPR 90 L6 IE2	0.92	7.51	1170	IE2- 82.5	80	74.9	0.62	2.26	6.4	2.9	2.5	3.5	0.0072	30
IE2-KPR 100 LX6	KPR 100 LX6 IE2	0.92	7.57	1160	IE2- 73	84.4	81.2	0.72	3.08	6.1	2.2	2.2	3.1	0.0139	36
IE2-KPER 112 MV6	KPER 112 MV6 IE2	0.92	***	***	IE2- ***	***	***	***	***	***	***	***	***	0.0155	48
IE2-KPER 112 MZ6	KPER 112 MZ6 IE2	2.2	***	***	IE2- ***	***	***	***	***	***	***	***	***	0.043	50
IE2-KPER 132 SX6T	KPER 132 SX6T IE2	***	***	***	***	***	***	***	***	***	***	***	***	***	***
IE2-KPER 132 S6	KPER 132 S6 IE2	3.6	29.6	1160	IE2- 87.5	86.8	85.4	0.81	6.4	5.7	1.8	1.2	2.8	0.023	55
IE2-KPER 132 M6	KPER 132 M6 IE2	4.5	37.2	1155	IE2- 87.5	87.2	86.1	0.82	8	5.7	2.1	1.9	2.9	0.029	66
IE2-WE1R 132 M6	K11R 132 M6 E1 IE2	4.5	36.9	1165	IE2- 87.5	86.0	83.4	0.79	8	5.3	1.8	1.6	2.5	0.043	76
IE2-WE1R 132 MX6	K11R 132 MX6 E1 IE2	6.6	54	1170	IE2- 89.5	88.5	87.1	0.8	11.5	5.6	1.9	1.7	2.9	0.053	85
IE2-WE1R 160 M6	K11R 160 M6 E1 IE2	9.0	73	1175	IE2- 89.5	88.9	87.0	0.82	16	5.8	2.2	2.0	2.7	0.113	118
IE2-WE2R 160 M6	K11R 160 M6 E2 IE2	9	73	1170	IE2- 89	89	87.7	0.81	15.5	5.7	1.9	1.7	2.7	0.053	103
IE2-WE1R 160 L6	K11R 160 L6 E1 IE2													0.145	135
IE2-WE2R 160 L6	K11R 160 L6 E2 IE2	13	106	1175	IE2- 90.3	89.9	88.1	0.83	22	6.4	2.5	2.2	2.8	0.166	155
IE2-WE1R 180 L6	K11R 180 L6 E1 IE2	16.5	134	1175	IE2- 90.2	89.8	88.4	0.85	27.0	7.3	2.2	1.9	2.7	0.228	185
IE2-WE2R 180 L6	K11R 180 L6 E2 IE2	15	122	1175	IE2- 90.2	89.5	87.4	0.83	25	6.3	2.5	1.9	2.9	0.166	157
IE2-WE1R 200 L6	K11R 200 L6 E1 IE2	22.0	179	1175	IE2- 91.7	90.1	88.5	0.85	35.5	6.6	2.2	1.8	2.7	0.268	208
IE2-WE1R 200 LX6	K11R 200 LX6 E1 IE2	25	202	1180	IE2- 91.7	91.2	90.0	0.86	40.0	6.4	2.2	1.8	2.7	0.443	272
IE2-WE2R 200 LX6	K11R 200 LX6 E2 IE2	25	202	1180	IE2- 91.7	90.8	89.5	0.86	40	6.6	2.3	1.9	2.9	0.324	238
IE2-WE1R 225 M6	K11R 225 M6 E1 IE2	36	291	1182	IE2- 93.0	92.0	90.5	0.85	57.0	7.1	2.3	2.0	2.6	0.825	365
IE2-WE2R 225 M6	K11R 225 M6 E2 IE2	25	201	1185	IE2- 91.7	90.8	88.1	0.86	40	8.2	2.9	2.4	3.7	0.825	365
IE2-WE1R 250 M6	K11R 250 M6 E1 IE2	40	322	1185	IE2- 93.0	92.0	90.5	0.86	63	6.6	2.7	1.8	2.5	1.28	480
IE2-WE2R 250 M6	K11R 250 M6 E2 IE2	40	324	1179	IE2- 93	93.4	91.8	0.86	63	6.7	2.7	2.1	2.6	1.28	480
IE2-WE1R 280 S6	K11R 280 S6 E1 IE2	49	396	1183	IE2- 93.6	93.5	90.5	0.86	76.5	6.7	2.3	1.9	2.6	1.48	560
IE2-WE1R 280 M6	K11R 280 M6 E1 IE2	64	514	1190	IE2- 94.1	93.5	93.0	0.84	102	8.0	2.1	1.6	2.7	2.63	710
IE2-WE1R 315 S6	K11R 315 S6 E1 IE2	90	722	1190	IE2- 94.1	93.5	93.0	0.87	138	7.5	1.8	1.6	2.5	3.33	804
IE2-WE1R 315 M6	K11R 315 M6 E1 IE2	99	794	1190	IE2- 94.1	94.0	93.5	0.87	152	8.0	2.1	1.6	2.6	3.60	865
IE2-WE1R 315 MX6	K11R 315 MX6 E1 IE2	110	883	1190	IE2- 95.0	94.6	94.2	0.87	167	8.3	2.0	1.7	2.6	6.67	1210
IE2-WE1R 315 MY6	K11R 315 MY6 E1 IE2	145	1164	1190	IE2- 95.0	95.0	94.5	0.86	223	8.0	2.0	1.5	2.4	6.67	1250
IE2-WE1R 315 L6	K11R 315 L6 E1 IE2	175	1404	1190	IE2- 95.0	94.8	94.3	0.87	266	8.0	2.0	1.5	2.4	8.60	1430
IE2-WE1R 315 LX6	K11R 315 LX6 E1 IE2	220	1766	1190	IE2- 95.0	95.0	94.5	0.86	338	7.0	1.9	1.5	2.3	8.60	1460
IE2-WE2R 355 M6	W22R 355 M6 E1 IE2	280	2241	1193	IE2- 95.0	94.5	93.5	0.83	446	8.0	1.7	1.3	2.5	8.20	1850
IE2-WE2R 355 MX6	W22R 355 MX6 E1 IE2	330	2633	1197	IE2- 95.2	95.2	95.2	0.86	506	7.0	1.3	1.1	2.2	12.10	2200
IE2-WE2R 355 LY6	W22R 355 LY6 E1 IE2	375	2997	1195	IE2- 95.0	94.5	93.5	0.76	652	8.0	1.9	1.6	2.8	14.00	2400

***) upon request

Three-phase motors with squirrel-cage rotor for marine use, High Efficiency IE2

with surface cooling, duty type S1, continuous duty
for rated voltage, thermal class 155 (F), degree of protection IP 55, 60 Hz

Motor selection data													Design point 460 V, 60 Hz		
Type	Type	P_B	M_B	n_B	η_B			$\cos\varphi_B$	I_B	I_A/I_B	M_A/M_B	M_S/M_B	M_K/M_B	J	m
GL	DNV, RS, LR				(EN 60034-2-1)				460 V						
DNV-GL	BV, ABS, CCS														
RS (KP.. only)		kW	Nm	rpm	100%	75%	50%	-	A	-	-	-	-	kgm ²	kg
Synchronous 900 rpm – 8-pole version															
IE2-KPER 80 G8	KPER 80 G8 IE2	0.3	3.41	840	IE2- 52.0	56.1	48.5	0.57	1.1	3.0	1.9	1.9	2.1	0.0018	12
IE2-KPR 90 S8	KPR 90 S8 IE2	0.4	***)	***)	IE2- 58.0	***)	***)	***)	***)	***)	***)	***)	***)	0.0063	24
IE2-KPR 90 L8	KPR 90 L8 IE2	0.7	***)	***)	IE2- 66.0	***)	***)	***)	***)	***)	***)	***)	***)	0.0072	26
IE2-KPR 100 L8	KPR 100 L8 IE2	0.9	9.94	865	IE2- 66.0	80.0	76.6	0.66	2.1	4.8	2.2	2.2	2.8	0.0123	33.5
IE2-KPR 100 LX8	KPR 100 LX8 IE2	1.3	13.72	870	IE2- 75.5	74.3	70.4	0.63	3.1	4.0	1.6	1.5	2.5	0.0139	36
IE2-KPER 112 MV8	KPER 112 MV8 IE2	1.3	13.64	875	IE2- 75.5	77.6	72.7	0.54	3.6	3.8	2.0	1.9	2.9	0.0155	48
IE2-KPER 132 S8	KPER 132 S8 IE2														
IE2-KPER 132 M8	KPER 132 M8 IE2														
IE2-WE1R 132 M8	K11R 132 M8 E1 IE2	3.6	39.5	870	IE2- 84.2	84.5	83.0	0.75	7.2	3.6	1.4	1.2	1.8	0.0430	74
IE2-WE1R 160 M8	K11R 160 M8 E1 IE2	4.5												0.0530	86
IE2-WE1R 160 MX8	K11R 160 MX8 E1 IE2	6.6	72	875	IE2- 87.8	87.2	84.6	0.74	12.7	4.9	2.0	1.6	2.4	0.1130	115
IE2-WE2R 160 MX8	K11R 160 MX8 E2 IE2	6.6	73	865	IE2- 86.4	86.7	85.3	0.72	13.5	4.2	1.6	1.4	2.3	0.0530	103
IE2-WE1R 160 L8	K11R 160 L8 E1 IE2	8.5												0.1450	136
IE2-WE1R 180 L8	K11R 180 L8 E1 IE2	13.0	141	878	IE2- 89.4	89.4	87.9	0.78	23.5	4.6	1.7	1.5	2.3	0.2280	175
IE2-WE2R 180 L8	K11R 180 L8 E2 IE2	13												0.1660	157
IE2-WE1R 200 L8	K11R 200 L8 E1 IE2	18.0	196	878	IE2- 88.9	88.7	87.4	0.78	32.5	4.8	1.8	1.6	2.2	0.2680	200
IE2-WE1R 225 S8	K11R 225 S8 E1 IE2	22	239	880	IE2- 89.9	89.6	87.5	0.79	39.0	5.2	2.0	1.9	2.7	0.44	265
IE2-WE2R 225 S8	K11R 225 S8 E2 IE2	22	237	885	IE2- 91.8	91.5	90.2	0.81	37.0	5.7	2	1.7	2.6	0.51	305
IE2-WE1R 225 M8	K11R 225 M8 E1 IE2	33	356	885	IE2- 91.5	91.0	89.5	0.78	58.0	5.6	2.1	1.8	2.4	0.83	380
IE2-WE2R 225 M8	K11R 225 M8 E2 IE2	26	281	883	IE2- 91.3	91.1	89.6	0.79	45.0	5.9	2.1	1.8	2.7	0.51	307
IE2-WE1R 250 M8	K11R 250 M8 E1 IE2	36	391	880	IE2- 91.7	92.0	90.8	0.79	62.5	5.3	2.1	1.7	2.2	0.83	380
IE2-WE1R 280 S8	K11R 280 S8 E1 IE2	44	476	883	IE2- 91.7	91.7	91.1	0.80	75.5	4.6	1.8	1.4	1.9	1.35	480
IE2-WE1R 280 M8	K11R 280 M8 E1 IE2	54	582	886	IE2- 93.0	92.2	91.1	0.79	92.0	5.5	2.1	1.6	2.3	1.55	535
IE2-WE1R 315 S8	K11R 315 S8 E1 IE2	66	708	890	IE2- 93.0	93.0	92.5	0.80	111	5.8	1.6	1.4	2.0	2.63	715
IE2-WE1R 315 M8	K11R 315 M8 E1 IE2	90	966	890	IE2- 93.6	93.6	93.4	0.82	147	6.0	1.5	1.3	2.0	3.33	805
IE2-WE1R 315 MX8	K11R 315 MX8 E1 IE2	108	1159	890	IE2- 93.6	93.6	93	0.81	179	6.2	1.6	1.3	2.0	3.60	850
IE2-WE1R 315 MY8	K11R 315 MY8 E1 IE2	132	1416	890	IE2- 93.6	93.6	93.6	0.82	216	6.0	1.6	1.4	2.0	6.00	1080
IE2-WE1R 315 L8	K11R 315 L8 E1 IE2	145	1556	890	IE2- 93.6	93.6	93.6	0.83	234	6.0	1.6	1.4	2.0	6.76	1250
IE2-WE1R 315 LX8	K11R 315 LX8 E1 IE2	190	2039	890	IE2- 94.3	94.3	94.0	0.81	312	7.0	2.1	1.7	2.3	8.71	1430
IE2-WE2R 355 M8	W22R 355 M8 E1 IE2													9.50	1850
IE2-WE2R 355 MX8	W22R 355 MX8 E1 IE2													13.40	2200
IE2-WE2R 355 LY8	W22R 355 LY8 E1 IE2													15.80	2400

***) upon request

Three-phase motors with squirrel-cage rotor for marine use

with surface cooling, duty type S1, continuous duty
for rated voltage, thermal class 155 (F), degree of protection IP 55, 50 Hz

Motor selection data														Design point 400 V, 380 V, 50 Hz	
Type	Type	P _B GL, RS DNV-GL kW	P _B BV, DNV LR, ABS, CCS kW	M _B Nm	n _B rpm	η _B (EN 60034-2) 100 %	cosφ _B -	I _B 400 V A	I _B 380 V A	I _A /I _B -	M _A /M _B -	M _G /M _B -	M _K /M _B -	J kgm ²	m kg
Synchronous 3000 rpm – 2-pole version															
KPER 56 K2		0.09	0.09	0.3	2840	70.0	0.74	0.25	0.26	4.9	2.3	2.3	2.8	0.00013	4.4
KPER 56 G2		0.12	0.12	0.4	2830	70.3	0.77	0.32	0.34	4.5	2.1	2.1	2.3	0.00013	4.5
KPER 63 K2	KPR 56 K2	0.18	0.18	0.6	2765	68	0.79	0.48	0.51	4.1	1.7	1.7	2.0	0.00013	4.9
KPER 63 G2	KPR 56 G2	0.25	0.25	0.9	2775	67	0.79	0.68	0.72	4.2	2.0	2.0	2.2	0.00015	5.2
KPER 71 K2	KPR 63 K2	0.37	0.37	1.3	2745	71.5	0.85	0.88	0.93	4.2	1.9	1.9	2.1	0.00025	6.7
KPER 71 G2	KPR 63 G2	0.55	0.55	1.9	2730	73.5	0.86	1.26	1.33	5.0	1.9	1.9	2.3	0.00032	7.6
KPER 80 K2	KPR 71 K2	0.75	0.75	2.6	2795	77.5	0.85	1.65	1.74	5.6	2.2	2.2	2.3	0.00057	10.7
KPER 80 G2	KPR 71 G2	1.1	1.1	3.7	2810	77	0.84	2.46	2.59	5.6	2.2	2.1	2.4	0.00072	11.5
KPER 90 S2	KPR 80 K2	1.5	1.5	5.1	2810	80	0.88	3.09	3.25	6.7	2.3	2.3	2.6	0.00132	16.0
KPER 90 L2	KPR 80 G2	2.2	2.2	7.4	2830	82	0.88	4.42	4.65	7.0	2.6	2.1	2.6	0.0017	19.0
KPER 100 L2	KPR 90 L2	3.0	3.0	10.1	2840	82.5	0.87	6.03	6.35	6.4	2.2	2.1	2.5	0.00275	25.0
KPER 112 M2	KPR 100 S2	4.0	4.0	13.2	2885	85.5	0.85	8.08	8.50	6.7	2	1.9	2.6	0.0045	32
KPER 112 MX2	KPR 100 L2	5.5	5.5	18.3	2875	85.5	0.87	10.64	11.2	7.0	2.2	2.0	2.7	0.0055	38
KPER 132 S2T		5.5	5.5	18.2	2890	85.9	0.84	11.0	11.6	7.5	2.4	2.2	3	0.0055	40
KPER 132 S2	KPR 112 MY2	5.5	5.5	18.4	2860	85.7	0.86	11.0	11.6	5.5	1.8	1.6	2.2	0.0081	52
KPER 112 MV2	KPR 100 LV2	7.5	7.5	24.9	2880	87.1	0.84	14.8	15.6	6.3	1.5	1.2	2.6	0.0068	46
KPER 132 SX2T		7.5	7.5	24.9	2880	87.1	0.84	14.8	15.6	6.3	1.5	1.2	2.6	0.0068	48
KPER 132 SX2	KPR 112 M2	7.5	7.5	24.7	2900	87	0.86	14.5	15.3	6.6	1.8	1.3	2.5	0.011	57
KPER 132 M2		11.0	11.0												
K11R 160 M2	K10R 132 M2	11	11	36	2900	88.5	0.90	20.0	21	7	2.4	2	2.4	0.0258	81
K11R 160 MX2	K10R 160 S2	15	15	49	2930	89.4	0.90	27.1	28.5	7.1	2.2	1.7	2.9	0.0575	118
K11R 160 L2	K10R 160 M2	18.5	18.5	61	2920	90.5	0.92	32.3	34	7.2	2.1	1.6	2.6	0.0675	134
K11R 180 M2	K10R 180 S2	22	22	72	2935	91.8	0.92	37.5	39.5	6.8	1.7	1.4	2.6	0.105	165
K11R 200 L2	K10R 180 M2	30	30	97	2940	92.8	0.92	50.8	53.5	7.3	2	1.6	2.9	0.128	195
K11R 200 LX2	K10R 200 M2	37	37	120	2940	93.0	0.90	64	67	7	1.8	1.3	2.4	0.193	255
K11R 225 M2	K10R 200 L2	45	45	146	2940	93.7	0.91	76	80	7.5	1.8	1.4	2.7	0.220	290
K11R 250 M2	K10R 225 M2	55	55	178	2955	93.7	0.91	93	98	7.5	2	1.5	2.6	0.375	360
K11R 280 S2	K10R 250 S2	75	75	241	2970	94.6	0.92	124	131	7.5	2	1.6	2.6	0.650	490
K11R 280 M2	K10R 250 M2	90	90	289	2970	94.7	0.91	151	159	8.5	2.2	1.8	2.8	0.675	510
K11R 315 S2	K10R 280 S2	110	110	353	2975	95.4	0.91	183	193	8.5	1.5	1.3	2.5	1.21	720
K11R 315 M2	K10R 280 M2	132	132	424	2975	95.4	0.91	219	231	8.5	2	1.8	2.7	1.44	800
K11R 315 MX2	K10R 315 S2	160	160	514	2975	96.0	0.93	258	272	8.5	2	1.6	2.6	1.76	980
K11R 315 MY2	K10R 315 M2	200	200	643	2970	96.0	0.92	327	344	8.2	2.6	2	2.6	2.82	1170
K11R 315 L2	K10R 315 L2	250	250	803	2973	96.1	0.93	404	425	7.3	2.1	1.4	2	3.66	1460
K11R 315 LX2	K10R 315 LX2	280	280	902	2965	96.7	0.92	454	478	8.2	2.6	1.6	2.2	4.43	1630
K22R 355 M2		315	315	1008	2985	96.8	0.91	520	547	8.2	1.4	1.0	3.0	4.20	2000
K22R 355 MX2		355	355	1136	2985	96.9	0.91	580	610	8.5	1.4	1.0	2.9	5.50	2200
K22R 355 LY2		400	400	1280	2985	97.1	0.91	650	685	8.6	1.6	1.0	2.9	7.10	2400
K22R 355 L2		450	450	1440	2985	97.2	0.92	725	765	9	2.0	0.9	2.8	7.10	2400

Three-phase motors with squirrel-cage rotor for marine use

with surface cooling, duty type S1, continuous duty
for rated voltage, thermal class 155 (F), degree of protection IP 55, 50 Hz

Motor selection data														Design point 400 V, 380 V, 50 Hz	
Type	Type	P _B GL, RS	P _B BV, DNV	M _B	n _B	η _B (EN 60034-2)	cosφ _B	I _B 400 V	I _B 380 V	I _A /I _B	M _A /M _B	M _G /M _B	M _K /M _B	J	m
		DNV-GL	LR, ABS, CCS	Nm	rpm	100 %	-	A	A	-	-	-	-	kgm ²	kg
Synchronous 1500 rpm – 4-pole version															
KPER 56 K4		0.06	0.06	0.41	1410	60.1	0.6	0.24	0.25	3.1	2.3	2.3	2.7	0.00019	4.3
KPER 56 G4		0.09	0.09	0.63	1375	61.6	0.68	0.31	0.33	3.2	1.9	1.9	2.2	0.00019	4.4
KPER 63 K4	KPR 56 K4	0.12	0.12	0.8	1360	57.5	0.7	0.43	0.45	3.1	1.7	1.6	2.0	0.00019	4.8
KPER 63 G4	KPR 56 G4	0.18	0.18	1.3	1340	63	0.7	0.59	0.62	3.2	1.8	1.8	2.1	0.00024	5.2
KPER 71 K4	KPR 63 K4	0.25	0.25	1.7	1370	64.5	0.76	0.73	0.77	3.5	1.6	1.6	1.9	0.00040	6.8
KPER 71 G4	KPR 63 G4	0.37	0.37	2.6	1345	68	0.78	1.01	1.06	3.6	1.8	1.8	2.0	0.00050	7.8
KPER 80 K4	KPR 71 K4	0.55	0.55	3.8	1390	70.5	0.74	1.52	1.60	4.2	2.0	1.9	2.1	0.00087	10.6
KPER 80 G4	KPR 71 G4	0.75	0.75	5.2	1380	71.5	0.74	2.04	2.15	4.4	2.1	2.0	2.2	0.00107	11.7
KPER 90 S4	KPR 80 K4	1.1	1.1	7.5	1400	75.5	0.83	2.52	2.65	5.0	2.1	2.0	2.2	0.00207	15.5
KPER 90 L4	KPR 80 G4	1.5	1.5	10.3	1390	77.5	0.84	3.33	3.50	5.2	2.3	2.2	2.4	0.00260	18.0
KPER 100 L4	KPR 90 L4	2.2	2.2	15.1	1395	82	0.81	4.80	5.05	5.6	2.2	2	2.3	0.00400	23.5
KPER 100 LX4	KPR 100 S4	3.0	3.0	20.2	1420	82	0.82	6.41	6.75	6.1	2.3	2	2.6	0.00725	30
KPER 112 M4	KPR 100 L4	4.0	4.0	26.8	1425	83	0.81	8.55	9.00	6.7	2.4	2.3	2.8	0.00900	37
KPER 112 MX4	KPR 100 LX4	5.5	5.5	36.9	1425	86.3	0.78	11.80	12.4	6.3	2.5	2.4	2.9	0.011	45
KPER 132 S4T		5.5	5.5	36.9	1425	86.3	0.78	11.80	12.4	6.3	2.5	2.4	2.9	0.011	47
KPER 132 S4	KPR 112 M4	5.5	5.5	36.5	1440	85.7	0.89	10.50	11.1	6.5	1.9	1.7	3	0.015	50
KPER 132 M4		7.5	7.5					14.90	15.7						
K11R 132 M4	K10R 132 S4	7.5	7.5	49	1450	86	0.84	15.2	16	6	2	1.7	2.9	0.0280	70
K11R 160 M4	K10R 132 M4	11	11	72	1450	86	0.85	21.9	23	6.8	2.2	1.9	3.3	0.0350	92
K11R 160 L4	K10R 160 S4	15	15	98	1465	88	0.86	28.5	30	7.3	2.5	2	3	0.0780	120
K11R 180 M4	K10R 160 M4	18.5	17.5	121	1460	88.5	0.86	35.2	37	6.8	2.5	2	2.9	0.0900	136
K11R 180 L4	K10R 180 S4	22	22	143	1465	90.5	0.84	41.8	44	6.5	2	1.8	2.6	0.1380	170
K11R 200 L4	K10R 180 M4	30	30	196	1465	91.5	0.85	55.6	58.5	7	2	1.7	2.4	0.1680	200
K11R 225 S4	K10R 200 M4	37	37	240	1470	92.5	0.86	67.0	70.5	7	2	1.7	2.5	0.2750	270
K11R 225 M4	K10R 200 L4	45	43	292	1470	93	0.86	81.2	85.5	7	2	1.7	2.5	0.3130	300
K11R 250 M4	K10R 225 M4	55	55	356	1475	93.5	0.86	99	104	7	2.2	1.7	2.3	0.5250	375
K11R 280 S4	K10R 250 S4	75	75	484	1480	94.1	0.86	134	141	7	2	1.7	2.2	0.9500	520
K11R 280 M4	K10R 250 M4	90	90	581	1480	94.6	0.86	160	168	7	2.1	1.6	2.2	1.10	580
K11R 315 S4	K10R 280 S4	110	110	707	1485	95.1	0.86	194	204	7.5	1.8	1.6	2.2	1.96	740
K11R 315 M4	K10R 280 M4	132	132	849	1485	95.1	0.86	233	245	7	1.8	1.5	2.2	2.27	840
K11R 315 MX4	K10R 315 S4	160	160	1032	1480	95	0.87	279	294	7	1.8	1.5	2	2.73	1000
K11R 315 MY4	K10R 315 M4	200	200	1286	1485	96	0.88	342	360	7.5	2	1.8	2.4	4.82	1200
K11R 315 L4	K10R 315 L4	250	250	1608	1485	96.1	0.9	417	439	8	2	1.6	2.3	5.93	1450
K11R 315 LX4	K10R 315 LX4	280	280	1795	1490	96.5	0.88	476	501	8.6	1.9	1.5	2.5	6.82	1630
K22R 355 M4		315	315	2016	1492	1495	96.8	0.85	555	585	9.0	2.0	1.3	3.4	7.90
K22R 355 MX4		355	355	2268	1495	1495	96.8	0.84	630	665	9.2	2.0	1.3	3.8	9.50
K22R 355 LY4		400	400	2555	1495	1495	96.8	0.82	730	770	9.0	2.1	1.3	4.0	10.0

Three-phase motors with squirrel-cage rotor for marine use

with surface cooling, duty type S1, continuous duty
for rated voltage, thermal class 155 (F), degree of protection IP 55, 50 Hz

Motor selection data														Design point 400 V, 380 V, 50 Hz		
Type	Type	P _B GL, RS	P _B BV, DNV	M _B	n _B	η _B (EN 60034-2)	cosφ _B	I _B 400 V	I _B 380 V	I _A /I _B	M _A /M _B	M _G /M _B	M _K /M _B	J	m	
		DNV-GL	LR, ABS, CCS			100 %	-	A	A	-	-	-	-	kgm ²	kg	
Synchronous 1000 rpm – 6-pole version																
KPER 63 K6	KPR 56 K6	0.09	0.09	1.0	880	51.5	0.59	0.43	0.45	2.4	1.9	1.9	2.2	0.00024	4.9	
KPER 63 G6	KPR 56 G6	0.12	0.12	1.3	865	52	0.62	0.54	0.57	2.4	1.8	1.8	2.0	0.00027	5.7	
KPER 71 K6	KPR 63 K6	0.18	0.18	1.9	920	61	0.55	0.78	0.82	2.8	1.5	1.5	1.8	0.00045	7.4	
KPER 71 G6	KPR 63 G6	0.25	0.25	2.7	900	61	0.58	1.02	1.07	2.8	1.8	1.8	2.0	0.00060	8.3	
KPER 80 K6	KPR 71 K6	0.37	0.37	3.9	905	66	0.69	1.17	1.23	3.3	1.8	1.8	1.8	0.00130	11.0	
KPER 80 G6	KPR 71 G6	0.55	0.55	5.9	895	67	0.72	1.65	1.74	3.5	2.0	2.0	2.2	0.00175	12.5	
KPER 90 S6	KPR 80 K6	0.75	0.75	7.7	930	71	0.69	2.20	2.32	4.4	2.1	2.1	2.4	0.00325	16.0	
KPER 90 L6	KPR 80 G6	1.1	1.1	11.4	925	73	0.73	2.99	3.15	4.5	2.0	2.0	2.2	0.00425	19.0	
KPER 100 L6	KPR 90 L6	1.5	1.5	15.3	935	76.5	0.75	3.80	4.00	4.5	1.9	1.8	2.2	0.00625	24.0	
KPER 112 M6	KPR 100 L6	2.2	2.2	22.4	940	80	0.78	5.08	5.35	5.1	2.0	1.9	2.5	0.01225	33.5	
KPER 112 MX6	KPR 100 LX6	3.0	3.0	30.6	935	81.9	0.75	7.05	7.4	5.2	2.5	2.5	2.9	0.0139	***)	
KPER 132 S6T		3.0	3.0	30.6	935	81.9	0.75	7.05	7.4	5.2	2.5	2.5	2.9	0.0139	39	
KPER 132 S6	KPR 112 M6	3.0	3.0	30	955	78.5	0.82	6.70	7.1	5.7	1.8	1.6	2.7	0.018	46	
KPER 132 M6	KPR 112 MX6	4.0	4.0	40	955	80	0.8	9.00	9.5	6	2.2	2	3.1	0.023	53	
K11R 132 MX6	K10R 132 S6	5.5	5.5	55	955	83	0.83	11.4	12	5	1.8	1.5	2.3	0.0430	70	
K11R 160 M6	K10R 132 M6	7.5	7.5	75	960	85	0.82	15.7	16.5	5.5	2	1.6	2.5	0.0530	86	
K11R 160 L6	K10R 160 S6	11	11	109	965	85.2	0.86	21.9	23	5	2	1.7	2.3	0.1130	114	
K11R 180 L6	K10R 160 M6	14	13.5	139	965	86	0.83	28.5	30	6	2.4	2.1	2.7	0.1450	136	
K11R 200 L6	K10R 180 S6	18.5	18.5	182	970	88.1	0.87	34.7	36.5	5.5	2	1.7	2.4	0.2280	175	
K11R 200 LX6	K10R 180 M6	22	22	217	970	88.8	0.87	41.3	43.5	6.2	2.2	1.8	2.6	0.2680	200	
K11R 225 M6	K10R 200 M6	30	30	294	973	90.4	0.89	53.7	56.5	6.5	2.2	1.7	2.5	0.4430	265	
K11R 250 M6	K10R 225 M6	37	37	362	975	91	0.89	66.0	69.5	6.5	2.2	1.7	2.3	0.8250	360	
K11R 280 S6	K10R 250 S6	45	45	439	980	92	0.87	81.2	85.5	6	2	1.5	2	1.28	465	
K11R 280 M6	K10R 250 M6	55	55	536	980	92.5	0.88	98	103	6.5	2.3	1.7	2.4	1.48	520	
K11R 315 S6	K10R 280 S6	75	75	727	985	93.7	0.87	133	140	7	2	1.6	2.4	2.63	690	
K11R 315 M6	K10R 280 M6	90	90	868	990	94.4	0.88	157	165	7	2	1.7	2.4	3.33	800	
K11R 315 MX6	K10R 315 S6	110	110	1061	990	94	0.88	192	202	7.5	2.2	1.7	2.6	3.60	880	
K11R 315 MY6	K10R 315 M6	132	132	1273	990	95	0.88	228	240	7.5	2	1.7	2.4	6.00	1050	
K11R 315 L6	K10R 315 L6	160	160	1551	985	95.3	0.89	273	287	7.5	2.3	1.9	2.4	6.67	1250	
K11R 315 LX6	K10R 315 LX6	200	190	1929	990	95	0.87	350	368	8.3	2.2	2	2.7	8.6	1460	
K22R 355 M6		220	220	2114	994	995	96.0	0.84	400	420	8.4	1.8	1.2	3.2	1650	
K22R 355 MX6		250	250	2412	990	995	96.6	0.85	440	465	9.0	2.0	1.2	3.2	2200	
K22R 355 LY6		315	315	3039	990	995	96.6	0.84	560	590	8.8	2.0	1.2	3.4	2400	

***) upon request

Three-phase motors with squirrel-cage rotor for marine use

with surface cooling, duty type S1, continuous duty
for rated voltage, thermal class 155 (F), degree of protection IP 55, 50 Hz

Motor selection data														Design point 400 V, 380 V, 50 Hz	
Type	Type	P _B GL, RS	P _B BV, DNV	M _B	n _B	η _B (EN 60034-2)	cosφ _B	I _B 400 V	I _B 380 V	I _A /I _B	M _A /M _B	M _G /M _B	M _K /M _B	J	m
		DNV-GL	LR, ABS, CCS			100 %	-	A	A	-	-	-	-	kgm ²	kg
Synchronous 750 rpm – 8-pole version															
KPER 71 K8	KPR 63 K8	0.09	0.09	1.3	665	44.4	0.54	0.54	0.57	2.1	1.7	1.7	1.9	0.00050	6.6
KPER 71 G8	KPR 63 G8	0.12	0.12	1.7	660	47.6	0.55	0.67	0.70	2.3	1.6	1.6	2.0	0.00060	8.1
KPER 80 K8	KPR 71 K8	0.18	0.18	2.5	675	56.5	0.64	0.72	0.76	2.7	1.8	1.8	2.0	0.00130	10.5
KPER 80 G8	KPR 71 G8	0.25	0.25	3.5	685	60.1	0.59	1.02	1.07	3.0	2.1	2.1	2.3	0.00175	12.0
KPER 90 S8	KPR 80 K8	0.37	0.37	5.1	695	61.5	0.59	1.48	1.56	2.9	1.7	1.7	1.9	0.00300	15.0
KPER 90 L8	KPR 80 G8	0.55	0.55	7.6	690	64.5	0.62	1.97	2.07	3.1	1.7	1.7	2.0	0.00375	18.0
KPER 100 L8	KPR 90 L8	0.75	0.75	10.2	700	67	0.62	2.61	2.75	3.2	1.8	1.8	2.1	0.00625	23.0
KPER 100 LX8	KPR 100 S8	1.1	1.1	15.1	695	73	0.69	3.14	3.30	3.9	1.8	1.8	2.2	0.00900	28.0
KPER 112 M8	KPR 100 L8	1.5	1.5	20.6	695	74.5	0.73	3.99	4.20	4.1	2.0	1.9	2.3	0.01225	33.5
KPER 112 MX8	KPR 100 LX8	2.2	2.2	30.7	685	74.1	0.68	6.30	6.6	3.8	2	1.9	2.3	0.0139	***)
KPER 132 S8T		2.2	2.2	30.7	685	74.1	0.68	6.30	6.6	3.8	2	1.9	2.3	0.0139	39
KPER 132 S8	KPR 112 M8	2.2	2.2	29.8	705	75.5	0.76	5.50	5.8	4.5	1.7	1.6	2.3	0.018	46
KPER 132 M8	KPR 112 MX8	3.0	3.0	40.6	705	78	0.75	7.40	7.8	4.5	1.7	1.6	2.3	0.023	53
K11R 160 M8	K10R 132 S8	4	4	54	710	79.3	0.78	9.31	9.8	4	1.6	1.3	1.9	0.0430	70
K11R 160 MX8	K10R 132 M8	5.5	5.5	74	710	81.4	0.78	12.4	13	4.5	1.7	1.6	2.1	0.0530	86
K11R 160 L8	K10R 160 S8	7.5	7.5	99	725	83	0.78	16.6	17.5	4.5	1.8	1.6	2.1	0.1130	114
K11R 180 L8	K10R 160 M8	11	10.5	146	720	85	0.78	23.8	25	4.5	2	1.7	2.1	0.1450	136
K11R 200 L8	K10R 180 S8	15	15	198	725	86.5	0.79	31.8	33.5	5	2	1.7	2.3	0.228	175
	K10R 180 M8	18.5	17.5	244	725	87.5	0.8	38.0	40	5	1.9	1.7	2.2	0.268	
K11R 225 S8		18.5	17.5	244	725	89.2	0.83	36.1	38	5.5	2	1.6	2.2	0.440	265
K11R 225 M8	K10R 200 M8	22	22	290	725	89.2	0.84	42.3	44.5	5	1.8	1.5	2.2	0.440	265
K11R 250 M8	K10R 225 M8	30	30	392	730	90.2	0.79	60.8	64	5.5	2.2	1.8	2.2	0.825	360
K11R 280 S8	K10R 250 S8	37	37	481	735	91	0.8	73.2	77	5.5	2	1.5	2	1.35	465
K11R 280 M8	K10R 250 M8	45	45	585	735	91.5	0.77	92	97	6	2.3	1.8	2.4	1.55	520
K11R 315 S8	K10R 280 S8	55	55	710	740	93.1	0.8	106	112	6.5	1.8	1.6	2.3	2.63	690
K11R 315 M8	K10R 280 M8	75	75	968	740	93.3	0.81	143	151	6	2	1.6	2.3	3.33	800
K11R 315 MX8	K10R 315 S8	90	90	1161	740	93.5	0.81	172	181	6	1.9	1.6	2.2	3.60	880
K11R 315 MY8	K10R 315 M8	110	110	1420	740	94.6	0.81	207	218	6.5	2.1	1.8	2.4	6.00	1050
K11R 315 L8	K10R 315 L8	132	132	1704	740	95	0.83	241	254	6.3	2	1.7	2.1	6.76	1250
K11R 315 LX8	K10R 315 LX8	160	160	2065	740	95.2	0.79	307	323	7.2	2.2	1.9	2.5	8.71	1430
K22R 355 M8		180	180	2307	745	95.6	0.77	355	375	7.5	1.8	1.2	3.0	9.5	1600
K22R 355 MX8		200	200	2564	745	95.9	0.79	380	400	8.2	2.0	1.3	3.5	13.4	2200
K22R 355 LY8		250	250	3205	745	95.8	0.74	510	540	8.0	2.2	1.3	3.5	15.8	2400

***) upon request

Three-phase motors with squirrel-cage rotor for marine use

with surface cooling, duty type S1, continuous duty
for rated voltage, thermal class 155 (F), degree of protection IP 55, 60 Hz

Motor selection data														Design point 480 V, 440 V, 60 Hz	
Type	Type	P _B GL, RS	P _B BV, DNV	M _B	n _B	η _B (EN 60034-2)	cosφ _B	I _B 480 V	I _B 440 V	I _A /I _B	M _A /M _B	M _G /M _B	M _K /M _B	J	m
		DNV-GL	LR, ABS, CCS			100 %	-	A	A	-	-	-	-	kgm ²	kg
Synchronous 3600 rpm – 2-pole version															
KPER 56 K2		0.105	0.105	0.3	3460	71.0	0.68	0.25	0.27	5.8	2.6	2.6	3.3	0.00013	4.4
KPER 56 G2		0.14	0.14	0.4	3440	73.0	0.72	0.32	0.35	5.2	2.3	2.3	2.8	0.00013	4.5
KPER 63 K2	KPR 56 K2	0.21	0.21	0.6	3370	70.0	0.80	0.45	0.49	4.4	2.0	1.8	2.3	0.00013	4.9
KPER 63 G2	KPR 56 G2	0.30	0.30	0.8	3390	74.0	0.76	0.64	0.70	4.3	2.0	2.0	2.3	0.00015	5.2
KPER 71 K2	KPR 63 K2	0.44	0.44	1.3	3350	74.0	0.85	0.84	0.92	4.4	1.9	1.7	2.0	0.00025	6.7
KPER 71 G2	KPR 63 G2	0.65	0.65	1.9	3300	75	0.87	1.20	1.31	5.3	1.9	1.9	2.3	0.00032	7.6
KPER 80 K2	KPR 71 K2	0.90	0.90	2.5	3400	80.0	0.85	1.60	1.74	5.6	2.1	2.0	2.2	0.00057	10.7
KPER 80 G2	KPR 71 G2	1.3	1.3	3.7	3400	79.0	0.85	2.33	2.54	5.8	2.0	2.0	2.3	0.00072	11.5
KPER 90 S2	KPR 80 K2	1.8	1.8	5.0	3440	81	0.89	2.98	3.25	6.2	2.1	1.8	2.2	0.00132	16.0
KPER 90 L2	KPR 80 G2	2.6	2.6	7.3	3420	82.0	0.88	4.35	4.75	7.3	2.4	1.9	2.4	0.0017	19.0
KPER 100 L2	KPR 90 L2	3.6	3.6	10.0	3430	85.0	0.88	5.78	6.30	6.3	2.0	1.9	2.3	0.00275	25.0
KPER 112 M2	KPR 100 S2	4.8	4.8	13.2	3470	84.5	0.86	7.93	8.65	7.0	1.8	1.7	2.4	0.0045	32
KPER 112 MX2	KPR 100 L2	6.6	6.6	18.2	3460	85.0	0.89	10.5	11.5	8.0	2.0	1.8	2.5	0.0055	38
KPER 132 S2T			6.6	18.01	3500	86	0.84	11		8.8	2.4	2.2	3	0.0055	40
KPER 132 S2	KPR 112 MY2		6.6	18.38	3430	85.7	0.85	11		5.5	1.7	1.5	2.2	0.0081	52
KPER 112 MV2	KPR 100 LV2		9	24.7	3480	88	0.83	14.8		6.9	1.5	1.2	2.7	0.0068	46
KPER 132 SX2T			9	24.7	3480	88	0.83	14.8		6.9	1.5	1.2	2.7	0.0068	48
KPER 132 SX2	KPR 112 M2		9	24.7	3480	87	0.86	14.5		6.6	1.8	1.3	2.4	0.011	57
KPER 132 M2															
K11R 160 M2	K10R 132 M2	13	13	36	3480	88.0	0.90	19.7	21.5	7	2.4	1.9	3	0.0258	81
K11R 160 MX2	K10R 160 S2	18	18	49	3530	89.6	0.90	27.0	29.5	7.1	2.2	1.7	2.9	0.0575	118
K11R 160 L2	K10R 160 M2	22	22	60	3515	90.0	0.92	32.1	35	6.5	1.9	1.4	2.6	0.0675	134
K11R 180 M2	K10R 180 S2	26	26	70	3525	91.8	0.92	37.1	40.5	6.3	1.5	1.3	2.3	0.105	165
K11R 200 L2	K10R 180 M2	36	36	97	3535	92.5	0.92	50.9	55.5	6.9	2	1.5	2.7	0.128	195
K11R 200 LX2	K10R 200 M2	44	44	119	3535	93.0	0.91	62	68	6.5	1.6	1.2	2.3	0.193	255
K11R 225 M2	K10R 200 L2	54	54	146	3530	93.5	0.90	77	84	7	1.7	1.3	2.5	0.220	290
K11R 250 M2	K10R 225 M2	66	66	178	3545	93.5	0.90	94	103	6.8	1.8	1.4	2.3	0.375	360
K11R 280 S2	K10R 250 S2	90	90	241	3565	94.0	0.92	126	137	6.8	1.8	1.4	2.4	0.650	490
K11R 280 M2	K10R 250 M2	105	105	281	3565	94.5	0.91	147	160	7.6	2	1.6	2.6	0.675	510
K11R 315 S2	K10R 280 S2	132	132	353	3570	95.0	0.91	183	200	7.5	1.3	1.2	2.3	1.21	720
K11R 315 M2	K10R 280 M2	158	150	401	3570	95.4	0.91	219	239	7.7	1.8	1.6	2.3	1.44	800
K11R 315 MX2	K10R 315 S2	190	190	508	3570	96.0	0.92	259	282	7.6	1.8	1.5	2.4	1.76	980
K11R 315 MY2	K10R 315 M2	225	225	602	3568	95.8	0.91	311	339	8	2.6	2	2.6	2.82	1170
K11R 315 L2	K10R 315 L2	280	280	749	3570	96.0	0.92	381	416	6.6	1.9	1.3	1.8	3.66	1460
K11R 315 LX2	K10R 315 LX2	310	310	827	3580	96.7	0.91	424	462	8.8	2.9	1.7	2.4	4.43	1630
K22R 355 M2		340	340	906	3585									4.20	2000
K22R 355 MX2		390	390	1039	3585									5.50	2200
K22R 355 LY2		440	440	1172	3585									7.10	2400
K22R 355 L2		490	490	1305	3585									7.10	2400

Three-phase motors with squirrel-cage rotor for marine use

with surface cooling, duty type S1, continuous duty
for rated voltage, thermal class 155 (F), degree of protection IP 55, 60 Hz

Motor selection data														Design point 480 V, 440 V, 60 Hz	
Type	Type	P _B GL, RS	P _B BV, DNV	M _B	n _B	η _B (EN 60034-2)	cosφ _B	I _B 480 V	I _B 440 V	I _A /I _B	M _A /M _B	M _G /M _B	M _K /M _B	J	m
		DNV-GL	LR, ABS, CCS			100 %	-	A	A	-	-	-	-	kgm ²	kg
Synchronous 1800 rpm – 4-pole version															
KPER 56 K4			0.075	0.42	1710	63	0.6	0.24		3.5	2.5	2.5	2.9	0.00019	4.3
KPER 56 G4			0.105	0.59	1690	63	0.63	0.32		3.5	2.3	2.3	2.5	0.00019	4.4
KPER 63 K4	KPR 56 K4	0.14	0.14	0.8	1660	61.0	0.70	0.39	0.43	3.2	1.7	1.7	2.1	0.00019	4.8
KPER 63 G4	KPR 56 G4	0.21	0.21	1.2	1660	65.0	0.68	0.57	0.62	3.3	1.9	1.9	2.2	0.00024	5.2
KPER 71 K4	KPR 63 K4	0.30	0.30	1.7	1660	67.0	0.76	0.71	0.77	3.7	1.6	1.6	1.8	0.00040	6.8
KPER 71 G4	KPR 63 G4	0.44	0.44	2.5	1660	71.0	0.77	0.97	1.06	3.9	1.8	1.8	2.0	0.00050	7.8
KPER 80 K4	KPR 71 K4	0.65	0.65	3.7	1690	74.0	0.75	1.41	1.54	4.5	2.0	1.7	2.1	0.00087	10.6
KPER 80 G4	KPR 71 G4	0.90	0.90	5.1	1685	76.0	0.76	1.88	2.05	4.8	1.9	1.8	2.0	0.00107	11.7
KPER 90 S4	KPR 80 K4	1.3	1.3	7.3	1700	78.0	0.83	2.43	2.65	5.2	1.9	1.8	2.2	0.00207	15.5
KPER 90 L4	KPR 80 G4	1.8	1.8	10.2	1690	80.0	0.84	3.21	3.50	5.2	2.1	2.0	2.2	0.00260	18.0
KPER 100 L4	KPR 90 L4	2.6	2.6	14.6	1705	82.0	0.80	4.77	5.20	5.8	2.1	2	2.2	0.00400	23.5
KPER 100 LX4	KPR 100 S4	3.6	3.6	20.0	1715	82.0	0.83	6.37	6.95	6.2	2.1	1.8	2.4	0.00725	30
KPER 112 M4	KPR 100 L4	4.8	4.8	26.7	1720	85.0	0.83	8.25	9.00	6.6	2.3	2.1	2.8	0.00900	37
KPER 112 MX4	KPR 100 LX4		6.6	36.65	1720	87	0.76	12.2		6.7	2.5	2.5	2.9	0.011	45
KPER 132 S4T			6.6	36.65	1720	87	0.76	12.2		6.7	2.5	2.5	2.9	0.011	47
KPER 132 S4	KPR 112 M4		6.6	36.12	1745	84.5	0.88	10.5		6.5	1.9	1.7	3	0.015	50
KPER 132 M4															
K11R 132 M4	K10R 132 S4	9	9	49	1745	86	0.85	14.7	16	5.6	1.8	1.5	2.6	0.0280	70
K11R 160 M4	K10R 132 M4	13	13	71	1750	88	0.86	20.6	22.5	6.5	2	1.7	3	0.0350	92
K11R 160 L4	K10R 160 S4	18	18	98	1760	89	0.87	28.0	30.5	7	2.3	1.8	2.7	0.0780	120
K11R 180 M4	K10R 160 M4	22	20	109	1755	89.5	0.87	33.9	37	6.3	2.3	1.8	2.6	0.0900	136
K11R 180 L4	K10R 180 S4	26	26	141	1765	90.5	0.85	40.8	44.5	6.1	1.8	1.6	2.4	0.1380	170
K11R 200 L4	K10R 180 M4	36	34	184	1765	92	0.86	54.5	59.5	6.6	1.8	1.6	2.2	0.1680	200
K11R 225 S4	K10R 200 M4	44	44	238	1765	92.5	0.86	66.5	72.5	6.6	1.8	1.5	2.3	0.2750	270
K11R 225 M4	K10R 200 L4	54	49.5	267	1770	92	0.86	82.0	89.5	6.5	1.8	1.5	2.3	0.3130	300
K11R 250 M4	K10R 225 M4	66	63	340	1770	92.5	0.86	100	109	6.5	2	1.5	2	0.5250	375
K11R 280 S4	K10R 250 S4	90	90	484	1777	94	0.85	136	148	6.5	1.8	1.6	1.9	0.9500	520
K11R 280 M4	K10R 250 M4	105	105	564	1777	94.4	0.86	156	170	6.5	1.9	1.4	1.9	1.10	580
K11R 315 S4	K10R 280 S4	132	132	708	1780	95	0.85	196	214	7.3	1.6	1.4	2	1.96	740
K11R 315 M4	K10R 280 M4	158	158	849	1777	95	0.85	236	257	6.6	1.6	1.3	2	2.27	840
K11R 315 MX4	K10R 315 S4	190	190	1022	1775	94.5	0.86	281	307	6.6	1.6	1.4	1.8	2.73	1000
K11R 315 MY4	K10R 315 M4	225	225	1204	1785	96	0.88	320	349	7.4	1.9	1.8	2.3	4.82	1200
K11R 315 L4	K10R 315 L4	280	280	1498	1785	96.1	0.88	398	434	7.4	1.9	1.5	2.2	5.93	1450
K11R 315 LX4	K10R 315 LX4	310	310	1654	1790	96.8	0.88	438	478	8.8	1.9	1.6	2.5	6.82	1630
K22R 355 M4		340	340	1814	1790									7.9	2150
K22R 355 MX4		390	390	2081	1790									9.5	2400
K22R 355 LY4		440	440	2347	1790									10.0	2500

Three-phase motors with squirrel-cage rotor for marine use

with surface cooling, duty type S1, continuous duty
for rated voltage, thermal class 155 (F), degree of protection IP 55, 60 Hz

Motor selection data													Design point 480 V, 440 V, 60 Hz			
Type	Type	P _B GL, RS	P _B BV, DNV	M _B	n _B	η _B (EN 60034-2)	cosφ _B	I _B 480 V	I _B 440 V	I _A /I _B	M _A /M _B	M _G /M _B	M _K /M _B	J	m	
		DNV-GL	LR, ABS, CCS			100 %	-	A	A	-	-	-	-	kgm ²	kg	
Synchronous 1200 rpm – 6-pole version																
KPER 63 K6	KPR 56 K6	0.105	0.105	0.9	1085	53.0	0.58	0.41	0.45	2.7	1.9	1.9	2.2	0.00024	4.9	
KPER 63 G6	KPR 56 G6	0.14	0.14	1.2	1080	56.0	0.57	0.53	0.58	2.5	1.9	1.9	2.1	0.00027	5.7	
KPER 71 K6	KPR 63 K6	0.21	0.21	1.8	1120	65.0	0.53	0.73	0.80	3.2	1.4	1.4	1.7	0.00045	7.4	
KPER 71 G6	KPR 63 G6	0.30	0.30	2.6	1100	64.0	0.58	0.97	1.06	3.2	1.6	1.6	1.8	0.00060	8.3	
KPER 80 K6	KPR 71 K6	0.44	0.44	3.8	1110	67.0	0.74	1.07	1.17	3.6	1.7	1.6	1.7	0.00130	11.0	
KPER 80 G6	KPR 71 G6	0.65	0.65	5.6	1110	71.0	0.71	1.56	1.70	3.8	1.9	1.8	2.0	0.00175	12.5	
KPER 90 S6	KPR 80 K6	0.90	0.90	7.6	1130	73.0	0.68	2.20	2.40	4.7	1.9	1.9	2.2	0.00325	16.0	
KPER 90 L6	KPR 80 G6	1.3	1.3	11.1	1120	75.0	0.70	2.98	3.25	4.5	1.8	1.8	2.0	0.00425	19.0	
KPER 100 L6	KPR 90 L6	1.8	1.8	15.2	1130	79.0	0.75	3.67	4.00	4.8	1.7	1.6	2.0	0.00625	24.0	
KPER 112 M6	KPR 100 L6	2.6	2.6	21.8	1140	81.0	0.81	4.77	5.20	5.8	1.8	1.7	2.3	0.01225	33.5	
KPER 112 MX6	KPR 100 LX6		3.6	30.16	1140	82.5	0.75	7		5.6	2	2.2	2.7	0.0139	***	
KPER 132 S6T			3.6	30.16	1140	82.5	0.75	7		5.6	2	2.2	2.7	0.0139	39	
KPER 132 S6	KPR 112 M6		3.6	29.77	1155	79	0.79	7		5.7	1.9	1.6	2.7	0.018	46	
KPER 132 M6	KPR 112 MX6		4.8	39.69	1155	80	0.78	9		6	2.2	2	3.1	0.023	53	
K11R 132 MX6	K10R 132 S6	6.6	6.6	55	1145	83	0.82	11.5	12.5	4.8	1.6	1.3	2	0.0430	70	
K11R 160 M6	K10R 132 M6	9	9	75	1145	85	0.82	15.6	17	5.2	1.8	1.4	2.2	0.0530	86	
K11R 160 L6	K10R 160 S6	13	13	107	1155	85.5	0.86	21.1	23	4.6	1.8	1.5	2	0.1130	114	
K11R 180 L6	K10R 160 M6	16	15.5	127	1165	87	0.83	26.6	29	5.8	2.2	1.9	2.6	0.1450	136	
K11R 200 L6	K10R 180 S6	21	21	172	1168	88.4	0.87	33.0	36	5.5	1.9	1.6	2.3	0.2280	175	
K11R 200 LX6	K10R 180 M6	26	26	212	1170	89.3	0.87	40.3	44	5.9	1.9	1.6	2.5	0.2680	200	
K11R 225 M6	K10R 200 M6	34	34	278	1170	90.3	0.88	51.3	56	5.9	1.8	1.5	2.4	0.4430	265	
K11R 250 M6	K10R 225 M6	42	42	342	1172	91.5	0.88	62.8	68.5	5.8	2	1.6	2.1	0.8250	360	
K11R 280 S6	K10R 250 S6	54	54	437	1180	92	0.87	81.1	88.5	5.5	1.8	1.4	1.8	1.28	465	
K11R 280 M6	K10R 250 M6	66	66	534	1180	92.5	0.88	97	106	6.5	2.2	1.7	2.2	1.48	520	
K11R 315 S6	K10R 280 S6	90	90	727	1182	93.5	0.87	133	145	6.5	1.8	1.4	2.2	2.63	690	
K11R 315 M6	K10R 280 M6	108	108	870	1185	94.5	0.87	158	172	6.5	1.8	1.5	2.1	3.33	800	
K11R 315 MX6	K10R 315 S6	132	132	1064	1185	94	0.88	192	209	7	2	1.6	2.4	3.60	880	
K11R 315 MY6	K10R 315 M6	158	158	1268	1190	95	0.88	227	248	7	1.9	1.6	2.3	6.00	1050	
K11R 315 L6	K10R 315 L6	190	180	1451	1185	95.2	0.89	270	294	7	2.2	1.8	2.3	6.67	1250	
K11R 315 LX6	K10R 315 LX6	230	220	1773	1185	95.2	0.89	326	356	7.7	2	1.8	2.5	8.6	1460	
K22R 355 M6		240	240	1926	1190									8.2	1650	
K22R 355 MX6		270	270	2167	1190									12.1	2200	
K22R 355 LY6		340	340	2729	1190									14.0	2400	

***) upon request

Three-phase motors with squirrel-cage rotor for marine use

with surface cooling, duty type S1, continuous duty
for rated voltage, thermal class 155 (F), degree of protection IP 55, 60 Hz

Motor selection data														Design point 480 V, 440 V, 60 Hz	
Type	Type	P _B GL, RS	P _B BV, DNV	M _B	n _B	η _B (EN 60034-2)	cosφ _B	I _B 480 V	I _B 440 V	I _A /I _B	M _A /M _B	M _G /M _B	M _K /M _B	J	m
		DNV-GL	LR, ABS, CCS	Nm	rpm	100 %	-	A	A	-	-	-	-	kgm ²	kg
Synchronous 900 rpm – 8-pole version															
KPER 71 K8	KPR 63 K8	0.105	0.105	1.2	820	50.0	0.54	0.47	0.51	2.3	1.6	1.6	1.7	0.00050	6.6
KPER 71 G8	KPR 63 G8	0.14	0.14	1.6	815	51.0	0.53	0.62	0.68	2.5	1.5	1.5	1.8	0.00060	8.1
KPER 80 K8	KPR 71 K8	0.21	0.21	2.4	830	60.0	0.62	0.68	0.74	2.8	1.6	1.6	1.8	0.00130	10.5
KPER 80 G8	KPR 71 G8	0.30	0.30	3.4	835	62.0	0.60	0.97	1.06	3.1	1.9	1.9	2.1	0.00175	12.0
KPER 90 S8	KPR 80 K8	0.44	0.44	4.9	850	65.0	0.57	1.43	1.56	3.6	1.6	1.6	1.7	0.00300	15.0
KPER 90 L8	KPR 80 G8	0.65	0.65	7.4	840	70.0	0.60	1.86	2.03	3.7	1.7	1.7	1.8	0.00375	18.0
KPER 100 L8	KPR 90 L8	0.90	0.90	10.1	850	69.0	0.63	2.48	2.70	3.7	1.6	1.6	1.9	0.00625	23.0
KPER 100 LX8	KPR 100 S8	1.3	1.3	14.6	850	76.0	0.69	2.98	3.25	4.2	1.6	1.6	2.0	0.00900	28.0
KPER 112 M8	KPR 100 L8	1.8	1.8	20.5	840	78.0	0.73	3.80	4.15	4.2	1.8	1.7	2.1	0.01225	33.5
KPER 112 MX8	KPR 100 LX8		2.6	29.56	840	77.3	0.66	6.15		4.1	1.6	1.6	2.1	0.0139	***)
KPER 132 S8T			2.6	29.56	840	77.3	0.66	6.15		4.1	1.6	1.6	2.1	0.0139	39
KPER 132 S8	KPR 112 M8		2.6	28.71	865	76	0.71	6		4.5	1.7	1.7	2.4	0.018	46
KPER 132 M8	KPR 112 MX8		3.6	40.21	855	78	0.73	8		4.4	1.7	1.6	2.3	0.023	53
K11R 160 M8	K10R 132 S8	4.8	4.8	54	850	79.5	0.75	9.6	10.5	3.8	1.4	1.1	1.7	0.0430	70
K11R 160 MX8	K10R 132 M8	6.6	6.6	73	860	82.3	0.77	12.4	13.5	4.1	1.5	1.4	2	0.0530	86
K11R 160 L8	K10R 160 S8	9	9	99	870	83.5	0.79	16.5	18	4	1.6	1.4	1.9	0.1130	114
K11R 180 L8	K10R 160 M8	13	12	132	865	86	0.78	23.4	25.5	4.1	1.8	1.6	2	0.1450	136
K11R 200 L8	K10R 180 S8	18	18	196	875	87.4	0.79	31.2	34	4.7	1.8	1.5	2	0.228	175
	K10R 180 M8	21	20	221	865	87.5	0.82	35.3	38.5	4	1.8	1.6	2	0.268	
K11R 225 S8		22	20	218	875	89	0.81	36.7	40	5	1.8	1.4	2	0.440	265
K11R 225 M8	K10R 200 M8	26	26	285	870	89.5	0.84	41.7	45.5	4.7	1.6	1.4	2	0.440	265
K11R 250 M8	K10R 225 M8	36	36	391	880	90.5	0.78	61.4	67	5.1	2	1.6	2	0.825	360
K11R 280 S8	K10R 250 S8	44	44	476	882	90.5	0.8	72.9	79.5	4.9	1.9	1.4	1.9	1.35	465
K11R 280 M8	K10R 250 M8	54	54	583	884	91.5	0.78	91	99.5	5.5	2.1	1.6	2.1	1.55	520
K11R 315 S8	K10R 280 S8	66	66	709	889	93.3	0.8	106	116	6.1	1.6	1.5	2	2.63	690
K11R 315 M8	K10R 280 M8	90	90	978	879	93	0.81	144	157	5.7	1.8	1.4	2	3.33	800
K11R 315 MX8	K10R 315 S8	108	108	1168	883	93.5	0.81	171	187	5.4	1.6	1.4	1.8	3.60	880
K11R 315 MY8	K10R 315 M8	132	132	1420	888	94.5	0.81	207	226	6.3	1.9	1.7	2.3	6.00	1050
K11R 315 L8	K10R 315 L8	158	158	1695	890	94.8	0.82	245	267	6	1.9	1.6	2	6.76	1250
K11R 315 LX8	K10R 315 LX8	190	190	2039	890	95.3	0.8	300	327	6.8	2	1.7	2.3	8.71	1430
K22R 355 M8		200	200	2146	890									9.5	1600
K22R 355 MX8		220	220	2361	890									13.4	2200
K22R 355 LY8		270	270	2897	890									15.8	2400

***) upon request

Terminal boxes

Marine design, sealed cable glands, power station design, VIK design

Type	Material	Adapter flange	Dimensions				Cable gland thread	Max. cable diameter	Terminal mounting	Number of terminals	Thread of terminal stud	Thread of protective conductor	Figure
			AG	LL	AH	BE							
			x	z	-	-							
Standard design													
KA 05	Alu	-	92	92	-	-	M20 x 1.5	Ø 13 mm	K1M4	6	M4	M4	
KA 05	Alu	-	92	92	-	-	M25 x 1.5	Ø 17 mm	K1M4	6	M4	M4	
KA 05-13	Alu	-	104	112	-	-	M20 x 1.5	Ø 13 mm	K1M4	6	M4	M4	
KA 05-13	Alu	-	104	112	-	-	M25 x 1.5	Ø 17 mm	K1M4	6	M4	M4	
KA 05-13	Alu	-	104	112	-	-	M32 x 1.5	Ø 21 mm	K1M4	6	M4	M4	
25 A	GG-15	-	143	134	-	-	M30 x 2	Ø 20.5 mm	SB 5/K1M5	6	M5	M6	01
63 A	GG-15	-	174	162	-	-	M36 x 2	Ø 23.5 mm	SB 6/K1M6	6	M6	M6	01
63 A	GG-15	-	174	162	-	-	M36 x 2	Ø 23.5 mm	SB 6/K1M6	6	M6	M6	01
100 A	GG-15	-	213	207	-	-	M45 x 2	Ø 32.5 mm	SB 8	6	M8	M8	01
200/100 A	GG-15	-	282	242	-	-	M56 x 2	Ø 41.5 mm	SB 8	6	M8	M8	01
200 A	GG-15	-	282	242	-	-	M56 x 2	Ø 41.5 mm	SB 10	6	M10	M10	01
400 A	GG-15	-	315	294	-	-	M56 x 2	Ø 41.5 mm	SB 12	6	M12	M10	02
400 B	GG-15	-	415	340	265	-	M56 x 2	Ø 41.5 mm	KM 12	6	M12	LK	03
400 B	GG-15	-	415	340	265	-	M72 x 2	Ø 56.5 mm	KM 12	6	M12	LK	03
630 A	GG-15	straight	496	390	301	140	M72 x 2	Ø 56.5 mm	KLP 630-20	6	M20	LK	04G
630 A	GG-15	inclined	496	390	301	140	M72 x 2	Ø 56.5 mm	KLP 630-20	6	M20	LK	04S
1000 A	GG-15	straight	615	474	385	200	M72 x 2	Ø 56.5 mm	KLSO 1000	6	StS	LK	05G
1000 A	GG-15	inclined	615	474	385	200	M72 x 2	Ø 56.5 mm	KLSO 1000	6	StS	LK	05S
1000 A	GG-15	straight	615	474	385	200	M80 x 2	Ø 68 mm	KLSO 1000	6	StS	LK	05G
1000 A	GG-15	inclined	615	474	385	200	M80 x 2	Ø 68 mm	KLSO 1000	6	StS	LK	05S
Sealed cable glands													
VGK 200 A	GG-15	-	387	242	-	-	Ø 66	Ø 66 mm	SB 10	6	M10	M10	06
VGK 400 A	GG-15	-	422	296	-	-	Ø 95	Ø 95 mm	SB 12	6	M12	M10	06
Power station design													
25 A KA	GG-15	-	143	134	-	-	M30 x 2	Ø 20.5 mm	KL 155	6	M5	M6	07
63 A KA	GG-15	-	184	172	-	-	M36 x 2	Ø 23.5 mm	KL 155	6	M5	M6	07
63 A KA	GG-15	-	184	172	-	-	M36 x 2	Ø 23.5 mm	K1 M6	6	M6	M6	07
63/100 A KA	GG-15	-	223	214	-	-	M45 x 2	Ø 32.5 mm	K1 M6	6	M6	M6	07
100 A KA	GG-15	-	213	207	-	-	M45 x 2	Ø 32.5 mm	K1 M8	6	M8	M8	07
200 A KA	GG-15	-	285	258	-	-	M56 x 2	Ø 41.5 mm	K1 M10	6	M10	M10	07
200 B KA	GG-15	-	330	270	200	-	M56 x 2	Ø 41.5 mm	K1 M10	6	M10	LK	03
400 A KA	GG-15	-	315	306	-	-	M56 x 2	Ø 41.5 mm	KM 12	6	M12	M10	07
VIK design													
KA 05-13	Alu	-	104	112	-	-	M20 x 1.5	Ø 13 mm	K1M4	6	M4	M4	
KA 05-13	Alu	-	104	112	-	-	M25 x 1.5	Ø 17 mm	K1M4	6	M4	M4	
KA 05-13	Alu	-	104	112	-	-	M32 x 1.5	Ø 21 mm	K1M4	6	M4	M4	
25 AV Ex eb IIC	GG-15	-	143	134	-	-	M32 x 1.5	Ø 21 mm	KL 155	6	M5	M6	07
63 AV Ex eb IIC	GG-15	-	184	172	-	-	M40 x 1.5	Ø 28 mm	KL 155	6	M5	M6	07
100/63 AV Ex eb IIC	GG-15	-	223	214	-	-	M40 x 1.5	Ø 28 mm	KM 8/6	6	M6	M6	08
100/63 AV Ex eb IIC	GG-15	-	223	214	-	-	M50 x 1.5	Ø 35 mm	KM 8/6	6	M6	M6	08
200 A-SB Ex eb IIC	GG-15	-	335	270	200	-	M50 x 1.5	Ø 35 mm	KM 10/8	6	LK	LK	09
200 A-SB Ex eb IIC	GG-15	-	335	270	200	-	M63 x 1.5	Ø 45 mm	KM 10/8	6	LK	LK	09
400 A-SB Ex eb IIC	GG-15	-	415	340	265	-	M63 x 1.5	Ø 45 mm	KM 16/12	6	LK	LK	09
630 A Ex eb IIC	GG-15	straight	496	390	301	140	M75 x 1.5	Ø 45 mm	KLP 630-20	6	LK	LK	10G
630 A Ex eb IIC	GG-15	inclined	496	390	301	140	M75 x 1.5	Ø 45 mm	KLP 630-20	6	LK	LK	10S
1000 A Ex eb IIC	GG-15	straight	615	474	385	200	M80 x 1.5	Ø 68 mm	KLSO 1000	6	StS	LK	11G
1000 A Ex eb IIC	GG-15	inclined	615	474	385	200	M80 x 1.5	Ø 68 mm	KLSO 1000	6	StS	LK	11S

StS... Busbars
LK... Terminal tabs

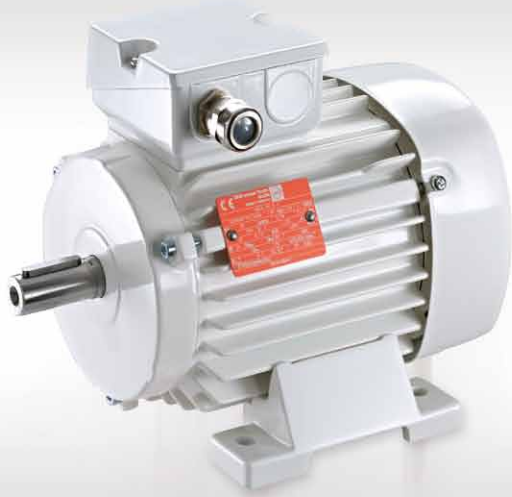

VEM  DRIVE

Permanent-magnet synchronous motors

Contents

Product description _____	12/2
Overview of technical data _____	12/4

Motor selection data

Series PE..	
for Super Premium Efficiency IE4 ¹⁾ _____	12/5
Series P..., high-power motors _____	12/7

Terminal boxes

Identical to terminal boxes of standard motors
see Chapter 2

Bearings

Identical to bearings of standard motors,
see Chapter 2

Dimensions

Identical to dimensions of standard motors see Chapter 2 and assignment tables _____	12/9
---	------

¹⁾ IE5 upon request (see VEMeKAT for latest status)

Product description

Permanent-magnet synchronous motors can be used wherever machines are to be driven with variable speed. As is the case for synchronous motors with separate excitation, a permanent-magnet synchronous motor also cannot be started directly on the mains. Permanent-magnet synchronous motors are intended solely for converter-fed operation. They represent a variant of standard motors, but are not to be considered replacements for servo drives.

As a permanent-magnet synchronous motor with field-oriented control displays similar characteristics to a DC machine, they were originally used almost exclusively for demanding variable-speed drive systems, as the elimination of brushes served to reduce maintenance costs.

Nowadays, they are in increasingly widespread use in applications where maximum efficiency is the prime concern. The especially high efficiency in both full and partial load operation permits the realisation of economical drive solutions for working machines of all kinds.

Permanent-magnet synchronous motors meet the requirements of efficiency classifications IE3 and IE4 without additional expense for materials. The double savings effect of high efficiency in operation (reduced energy consumption) alongside reduced material input for manufacture (for the P21 series compared to an asynchronous motor with equivalent output) qualifies a drive with permanent-magnet synchronous motor as a sustainable investment in the future.

Special notes regarding the calculation of a variable-speed drive system with permanent magnet synchronous motor

Permanent-magnet synchronous motors are excited by way of permanent magnets, i.e. the strength of the exciting field is determined when the machine is calculated and remains constant. There is thus no possibility for operation with field weakening in the classic manner known from asynchronous machines. Over the whole speed setting range (assumption: Rated speed = Maximum speed), the induced voltage is proportional to the speed.

If a correspondingly suitable converter is used, a limited field weakening range can be realised by modifying one component of the current.

The converter-fed operation of a permanent-magnet synchronous motor means that the standard assignment of a rated speed to a motor pole number and rated frequency (usually 50 Hz or 60 Hz) is no longer necessary. Optimum adaptation of the motor to the working machine or technological process, and similarly to the output voltage of the converter, is unproblematic.

A rated speed of 3000 rpm, for example, is realised with a 4-pole permanent-magnet synchronous motor with a 100 Hz winding. The product range does not include 2-pole permanent-magnet synchronous motors. On the other hand, lower rated speeds (e.g. 1200 or 900 rpm) can be realised with lower rated frequencies. Permanent-magnet synchronous motors can deliver very high overload torques, provided they

have been calculated accordingly and the converter is able to supply the necessary peak currents for the required duration.

As an option, permanent-magnet synchronous motors can also be supplied with position encoders. This enables precise determination of the speed of the magnet wheel and its position in the stator. In conjunction with field-oriented control, it is then possible to realise drives for applications which place very high demands on torque constancy and the accuracy of speed synchronisation, for example.

In case of high mass moments of inertia and fast speed changes, it may be necessary to use a brake resistor to protect the converter.

The motors can also be ordered as drive units with frequency converter. This brings the following benefits for the customer:

- Pre-parameterised unit
- Radio interference suppression to EN 55011, class A1, for shielded cable lengths up to 150 m
- Radio interference suppression to EN 55011, class B1, for shielded cable lengths up to 50 m
- Integrated brake chopper
- Mains input voltage 380 ...500 V \pm 10%, 50/60 Hz

Design versions

Series	Shaft height	Materials of housing, end shields and feet	Foot mounting
P.1R	63 bis 132 T	Grey cast iron	Bolted
PE2R	80 K4		Bolted
PE2R	71, 80 G4		Cast
P.1R	132 bis 280		Bolted
P2.R	315, 355		Cast
P20R	56 bis 80		Cast
P20R	90 bis 250		Bolted
P20R	280 bis 315		Cast

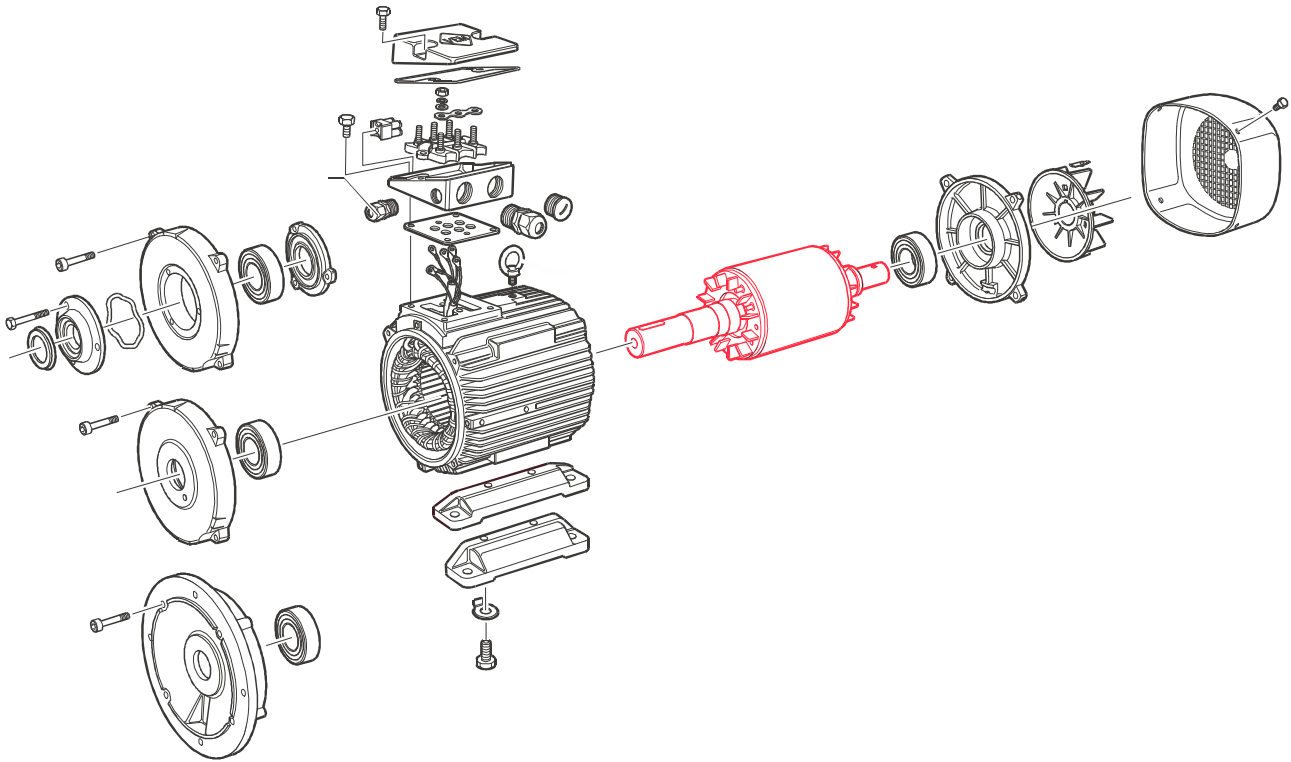

Fig. 1: Principle design of a PM motor

Outwardly, a permanent-magnet motor does not differ from an equivalent asynchronous motor. The design is based on that of the robust and reliable VEM standard motors in grey cast iron housing. The stator corresponds to the basic series K2.R, and the squirrel cage of an asynchronous

motor provides the basis for the magnet wheel (rotor). The squirrel-cage rotor body is turned after die-casting, neodymium iron boron magnets are glued around the body and the whole assembly is then bandaged (see photo below).



Fig. 2: PM rotor with magnets in place



Fig. 3: PM rotor complete with bandage

Overview of technical data

The most important technical data are summarised in the following table. Further information can be taken from the catalogue section "Technical explanations", chapter 1.

Product group	Magnetic rotor, IEC/EN
Rated output¹⁾	IE4-PE.R 63 bis 315, 0.12 to 250 kW P..R 63 bis 315, 0.12 bis 315 kW
Sizes	63 to 315
Housing material	Grey cast iron
Rated torque	0.8 Nm to 2000 Nm
Efficiency classification¹⁾/ efficiency determination	IEC DTS 60034-30-2 TS:2016 / IEC/TS 60034-2-3 Ed. 1.0: 2013
Method of connection	Single-speed motors are designed for star connection as standard.
Stator winding insulation	Thermal class 155 to IEC/EN 60034-1
Degree of protection	IP 55 to IEC/EN 60034-5
Type of cooling	IC 411, IC 416, IC 410, IC 418 IC 71W (IC 31W) upon request to EC/EN 60034-6
Coolant temperature/ installation altitude	Standard -20 °C to +40 °C, Altitude 1000 m above sea level
Rated voltage	Standard voltages to EN 60038 50 Hz: 230 V, 400 V, 500 V, 690 V 60 Hz: 275 V, 460 V, 480 V, 600 V
Duty Types	S1, continuous duty, Short-time duty S2, 10/30/60 min Duty Type S3/S6, 25/40/60 % c.d.f., S9
Types of construction	IM B3, IM B35, IM B5, IM B14, IM B34 and derived Types to IEC/EN 60034-7
Paint finish	Normal finish "Moderate", colour RAL 7031, blue-grey Special finish "Worldwide", colour RAL 7031, blue-grey
Vibration severity grade	Grade "A" as standard for machines with no special vibration requirements
Shaft ends	to DIN 748 (IEC 60072), balanced with half-key
Limit speeds	Please refer to the section of "Limit speeds" in catalogue section "Motors for converter-fed operation", Chapter 4.
Bearing design	Please refer to the tables of "Bearing design data" in catalogue section „Standand motors“, Chapter 2.
Motor mass	Please refer to the technical selection lists.
Terminal boxes	Please refer to the section "Terminal boxes" in catalogue section „Standand motors“, Chapter 2.
Documentation	An operating and maintenance manual, a terminal plan and a safety data sheet are supplied with each motor.
Tolerances	Please refer to the section "Tolerances" in catalogue section "Introduction", Chapter 1.
Options	Please refer to the section "Overview of modifications" in catalogue section "Introduction", Chapter 1.

¹⁾ IE5 upon request (see VEMeKAT for latest status)

Motor selection data

Permanent-magnet synchronous motors for converter-fed operation “Super Premium Efficiency IE4”¹⁾ according to IEC DTS 60034-30-2 TS 2016

with surface cooling, Type of cooling IC 411
Thermal class 155[F/B], degree of protection IP 55

Motor selection data																	Converter input voltage 400 V, 50 Hz			
		Speed	Frequency	Rated output	Torque	Max. torque (2 min)	Voltage	Efficiency	Power factor	Rated current	Phase resistance at 20 °C	No-load voltage at 1000 rpm	Magnetising inductance	Leakage inductance	Magnetising reactance	Leakage reactance	Motor moment of inertia	Motor mass		
																			rpm	Hz
Synchronous speed 3000 rpm – 4-pole version, rated frequency 100 Hz																				
IE4-PE1R 63 K4	IE4-PE0R 56 K4	3000	100	0.12	0.40	2.50	330	80	0.99	0.3	32	100	60	28	37.7	17.59	0.00019	4.8		
IE4-PE1R 63 K4	IE4-PE0R 56 K4	3000	100	0.18	0.60	2.50	335	80	0.99	0.35	32	100	60	28	37.7	17.59	0.00019	4.8		
IE4-PE1R 63 G4	IE4-PE0R 56 G4	3000	100	0.25	0.80	3.50	320	81.5	0.99	0.5	18	105	42	18	26.39	11.31	0.00024	5.2		
IE4-PE1R 71 K4	IE4-PE0R 63 K4	3000	100	0.37	1.20	4.00	320	83.2	0.99	0.81	13.5	100	37	15	23.25	9.42	0.00040	6.8		
IE4-PE1R 71 G4	IE4-PE0R 63 G4	3000	100	0.55	1.80	7.00	330	81.5	0.99	1.23	8.7	105	30	10	18.85	6.28	0.00050	7.8		
IE4-PE1R 80 K4	IE4-PE0R 71 K4	3000	100	0.75	2.40	10.00	335	84.2	0.99	1.55	4.6	110	25	8	15.71	5.03	0.00087	10.6		
IE4-PE1R 80 G4	IE4-PE0R 71 G4	3000	100	1.1	3.50	14.00	330	86.4	0.99	2.25	2.8	105	18	5	11.31	3.14	0.00107	11.7		
IE4-PE1R 90 S4	IE4-PE0R 80 K4	3000	100	1.5	4.80	19.00	310	86.8	0.99	3.25	1.7	105	9.5	2.5	5.97	1.57	0.00207	15.5		
IE4-PE1R 90 L4	IE4-PE0R 80 G4	3000	100	2.2	7.00	28.00	280	88.1	0.99	5.20	0.8	90	5	1	3.14	0.63	0.00260	18.0		
IE4-PE1R 100 L4	IE4-PE0R 90 L4	3000	100	3.0	9.50	45.00	320	92.7	0.99	5.90	0.6	100	4.7	1.3	2.95	0.82	0.00400	23.5		
IE4-PE1R 112 MY4	IE4-PE0R 100 S4	3000	100	4.0	12.70	50.00	330	91.2	0.99	7.75	0.4	110	3.2	0.8	2.01	0.50	0.00725	31.0		
IE4-PE1R 132 SY4T	IE4-PE0R 100 L4	3000	100	5.5	17.50	85.00	310	92.3	1.00	11.10	0.25	110	2	0.5	1.26	0.31	0.009	39		
IE4-PE1R 132 S4T	IE4-PE0R 100 LX4	3000	100	7.5	23.90	100.00	305	92.8	1.00	15.30	0.2	105	1.2	0.3	0.75	0.19	0.011	47		
IE4-PE1R 132 M4	IE4-PE0R 132 S4	3000	100	11.0	35.00	44.00	344	92.6	1.00	20.0	0.1170	121	2.280	0.960	1.432	0.603	0.022	72		
IE4-PE1R 132 M4	IE4-PE0R 132 S4	3000	100	15.0	48.00	60.00	347	93.4	1.00	26.7	0.1170	121	2.280	0.960	1.432	0.603	0.022	72		
IE4-PE1R 160 M4	IE4-PE0R 132 M4	3000	100	18.5	59.00	74.00	350	93.8	1.00	32.6	0.0690	116	1.660	0.630	1.042	0.396	0.031	92		
IE4-PE1R 160 L4	IE4-PE0R 160 S4	3000	100	18.5	59.00	74.00	372	93.9	0.99	31.0	0.0480	121	1.576	0.526	0.990	0.330	0.062	121		
IE4-PE1R 180 M4	IE4-PE0R 160 M4	3000	100	22.0	70.00	88.00	346	94.0	1.00	39.0	0.0410	123	1.350	0.460	0.848	0.289	0.079	135		
IE4-PE1R 180 M4	IE4-PE0R 160 M4	3000	100	30.0	96.00	120.00	347	94.5	0.99	53.5	0.0410	123	1.350	0.460	0.848	0.289	0.079	135		
IE4-PE1R 180 L4	IE4-PE0R 180 S4	3000	100	30.0	96.00	119.00	362	94.7	0.98	52.0	0.0270	116	1.150	0.360	0.722	0.226	0.116	170		
IE4-PE1R 200 L4	IE4-PE0R 180 M4	3000	100	37.0	118.00	147.00	365	95	0.98	63.0	0.0180	118	0.901	0.257	0.566	0.161	0.150	200		
IE4-PE1R 225 S4	IE4-PE0R 200 M4	3000	100	45.0	143.00	179.00	365	95.1	0.98	76.5	0.0110	118	0.725	0.198	0.455	0.124	0.251	270		
IE4-PE1R 225 M4	IE4-PE0R 200 L4	3000	100	55.0	175.00	218.00	355	95.4	0.98	96.0	0.0091	115	0.587	0.153	0.369	0.096	0.288	300		
IE4-PE1R 250 M4	IE4-PE0R 225 M4	3000	100	75.0	239.00	298.00	369	95.7	0.97	127.0	0.0073	118	0.543	0.144	0.341	0.090	0.457	375		
IE4-PE1R 250 M4	IE4-PE0R 225 M4	3000	100	90.0	287.00	358.00	374	96	0.96	151.0	0.0073	118	0.543	0.145	0.341	0.091	0.457	375		
IE4-PE1R 280 S4	IE4-PE0R 250 S4	3000	100	110.0	350.00	438.00	363	96.1	0.96	190.0	0.0045	115	0.420	0.111	0.264	0.070	0.864	520		
IE4-PE1R 280 S4	IE4-PE0R 250 S4	3000	100	132.0	420.00	525.00	370	96.4	0.94	228.0	0.0045	115	0.420	0.111	0.264	0.070	0.864	520		
IE4-PE1R 280 M4	IE4-PE0R 250 M4	3000	100	160.0	509.00	637.00	380	96.5	0.94	269.0	0.0037	118	0.373	0.085	0.234	0.053	1.011	580		
IE4-PE1R 315 MX4	IE4-PE0R 315 S4	3000	100	200.0	637.00	796.00	360	96.9	0.98	339.0	0.0019	117	0.152	0.038	0.095	0.024	1.556	980		
IE4-PE1R 315 MY4	IE4-PE0R 315 M4	3000	100	250.0	796.00	995.00	380	97.1	0.97	406.0	0.0018	123	0.161	0.036	0.101	0.023	2.499	1170		

¹⁾ IE5 upon request (see VEMeKAT for latest status)

**Permanent-magnet synchronous motors for converter-fed operation
“Super Premium Efficiency IE4”¹⁾ according to IEC DTS 60034-30-2 TS 2016**

with surface cooling, Type of cooling IC 411
Thermal class 155[F/B], degree of protection IP 55

Motor selection data												Converter input voltage 400 V, 50 Hz							
		Speed	Frequency	Rated output	Torque	Max torque (2 min)	Voltage	Efficiency	Power factor	Rated current	Phase resistance at 20 °C	No-load voltage at 1000 rpm	Magnetising inductance	Leakage inductance	Magnetising reactance	Leakage reactance	Motor moment of inertia	Motor mass	
		rpm	Hz	[kW]	[Nm]	[Nm]	[V]	100%	[-]	[A]	R _{1 20} [Ω]	U _{p0 20} [V/1000 rpm]	L _{1H} [mH]	L _{1σ} [mH]	X _{1H} [Ω]	X _{1σ} [Ω]	J kgm ²	m kg	
Synchronous speed 1500 rpm – 4-pole version, rated frequency 50 Hz																			
IE4-PE1R 63 K4	IE4-PE0R 56 K4	1500	50	0.12	0.8	2.5	310	76.0	0.98	0.3	95	170	160	80	50.3	25.13	0.00019	4.8	
IE4-PE1R 63 G4	IE4-PE0R 56 G4	1500	50	0.18	1.1	3.5	310	80.5	0.98	0.41	57	180	130	60	40.8	18.85	0.00024	5.2	
IE4-PE2R 71 K4	IE4-PE0R 71 K4	1500	50	0.25	1.6	10	290	84.4	1.00	0.65	14.5	190	76	24	23.9	7.54	0.00087	9.9	
IE4-PE2R 71 G4	IE4-PE0R 71 G4	1500	50	0.37	2.4	14	290	90.7	0.99	0.82	9.5	195	61	19	19.2	5.97	0.00107	11.0	
IE4-PE2R 80 K4	IE4-PE0R 71 G4	1500	50	0.55	3.5	14	300	87.6	0.99	1.22	9.5	195	61	19	19.2	5.97	0.00107	11.7	
IE4-PE2R 80 G4	IE4-PE0R 80 K4	1500	50	0.75	4.8	19	305	87.5	0.99	1.60	6	195	36	9	11.3	2.83	0.00207	14.5	
IE4-PE2R 90 S4	IE4-PE0R 80 G4	1500	50	1.1	7	28	300	91.5	0.99	2.35	3.4	190	24.5	5.5	7.7	1.73	0.00260	18.0	
IE4-PE1R 90 L4	IE4-PE0R 80 G4	1500	50	1.5	9.5	28	305	88.3	0.99	3.25	3.4	190	24.5	5.5	7.7	1.73	0.00260	18.0	
IE4-PE1R 100 L4	IE4-PE0R 90 L4	1500	50	2.2	14	45	315	90.5	0.99	4.5	2.1	195	15.5	4.5	4.9	1.41	0.00400	23.5	
IE4-PE1R 100 LX4	IE4-PE0R 100 S4	1500	50	3.0	19.1	50	335	91.6	0.99	5.7	1.5	215	16.0	4.0	5.0	1.26	0.00725	30.0	
IE4-PE1R 112 M4	IE4-PE0R 100 L4	1500	50	4.0	25.5	70	320	92.3	0.99	7.9	0.9	205	10.5	2.5	3.3	0.79	0.009	37.0	
IE4-PE1R 112 MX4	IE4-PE0R 100 LX4	1500	50	5.5	35	100	325	93.1	0.99	10.6	0.65	210	8.2	1.8	2.6	0.57	0.011	45.0	
IE4-PE1R 132 M4	IE4-PE0R 132 S4	1500	50	7.5	48.00	60.00	362	93.5	0.99	13.0	0.4290	232	8.379	3.486	2.631	1.095	0.022	70	
IE4-PE1R 160 M4	IE4-PE0R 132 M4	1500	50	11.0	70.00	88.00	362	94.1	0.99	19.0	0.2510	235	5.847	2.227	1.836	0.699	0.031	92	
IE4-PE1R 160 L4	IE4-PE0R 160 S4	1500	50	15.0	96.00	119.00	357	94.3	0.98	26.5	0.1250	229	3.717	1.306	1.167	0.410	0.068	120	
IE4-PE1R 180 M4	IE4-PE0R 160 M4	1500	50	18.5	118.00	147.00	364	94.8	0.98	32.0	0.1340	233	5.101	1.613	1.602	0.506	0.073	136	
IE4-PE1R 180 L4	IE4-PE0R 180 S4	1500	50	22.0	140.00	175.00	354	95	0.98	39.0	0.0720	226	2.840	0.937	0.892	0.294	0.126	170	
IE4-PE1R 200 L4	IE4-PE0R 180 M4	1500	50	30.0	191.00	239.00	360	95.3	0.98	52.0	0.0510	230	2.210	0.675	0.694	0.212	0.162	220	
IE4-PE1R 225 S4	IE4-PE0R 200 M4	1500	50	37.0	236.00	294.00	355	95.5	0.97	65.0	0.0290	228	1.800	0.531	0.565	0.167	0.269	270	
IE4-PE1R 225 M4	IE4-PE0R 200 L4	1500	50	45.0	287.00	358.00	363	95.7	0.98	77.0	0.0240	233	1.603	0.450	0.503	0.141	0.308	300	
IE4-PE1R 250 M4	IE4-PE0R 225 M4	1500	50	55.0	350.00	438.00	355	95.8	0.97	96.0	0.0170	228	1.231	0.347	0.387	0.109	0.492	375	
IE4-PE1R 250 M4	IE4-PE0R 225 M4	1500	50	75.0	478.00	597.00	366	96.1	0.98	126.0	0.0170	237	1.319	0.369	0.414	0.116	0.492	375	
IE4-PE1R 280 S4	IE4-PE0R 250 S4	1500	50	90.0	573.00	716.00	369	96.3	0.98	150.0	0.0120	239	1.176	0.283	0.369	0.089	0.911	520	
IE4-PE1R 280 M4	IE4-PE0R 250 M4	1500	50	110.0	700.00	875.00	359	96.4	0.96	191.0	0.0088	229	0.897	0.207	0.282	0.065	1.065	580	
IE4-PE1R 280 M4	IE4-PE0R 250 M4	1500	50	132.0	840.00	1050.00	373	96.5	0.98	216.0	0.0099	243	0.848	0.250	0.266	0.079	1.089	580	
IE4-PE1R 315 S4	IE4-PE0R 280 S4	1500	50	160.0	1019.00	1273.00	356	96.8	0.95	283.0	0.0060	224	0.727	0.155	0.228	0.049	1.750	740	
IE4-PE1R 315 MX4	IE4-PE0R 315 S4	1500	50	200.0	1273.00	1592.00	366	96.9	0.98	333.0	0.0044	239	0.484	0.114	0.152	0.036	2.350	1000	
IE4-PE1R 315 MY4	IE4-PE0R 315 M4	1500	50	250.0	1592.00	1990.00	372	97	0.96	418.0	0.0035	236	0.389	0.078	0.122	0.024	4.224	1200	
Synchronous speed 1000 rpm – 6-pole version, rated frequency 50 Hz																			
IE4-PE1R 132 MX6	IE4-PE0R 132 S6	1000	50	5.5	53.00	66.00	362	91.5	0.99	10.0	0.5350	348	6.624	3.072	2.080	0.965	0.040	70	
IE4-PE1R 160 M6	IE4-PE0R 132 M6	1000	50	7.5	72.00	90.00	364	91.7	0.99	13.0	0.3580	351	5.160	2.300	1.620	0.722	0.052	86	
IE4-PE1R 160 L6	IE4-PE0R 160 S6	1000	50	11.0	105.00	131.00	361	92.5	0.98	19.5	0.2390	345	4.549	1.729	1.428	0.543	0.104	114	
IE4-PE1R 180 L6	IE4-PE0R 160 M6	1000	50	15.0	143.00	179.00	360	93.1	0.98	26.5	0.1590	345	3.385	1.217	1.063	0.382	0.135	136	
IE4-PE1R 180 L6	IE4-PE0R 160 M6	1000	50	18.5	177.00	221.00	358	93.6	0.99	32.5	0.1545	347	3.403	1.217	1.069	0.382	0.135	136	
IE4-PE1R 200 L6	IE4-PE0R 180 S6	1000	50	22.0	210.00	263.00	359	93.9	0.99	38.0	0.1140	355	3.332	1.136	1.046	0.357	0.219	175	
IE4-PE1R 200 LX6	IE4-PE0R 180 M6	1000	50	30.0	287.00	358.00	359	94.3	0.98	52.5	0.0790	343	2.538	0.835	0.797	0.262	0.270	200	
IE4-PE1R 225 M6	IE4-PE0R 200 M6	1000	50	37.0	353.00	442.00	362	94.6	0.981	64.0	0.0495	350	1.899	0.610	0.596	0.192	0.437	265	
IE4-PE1R 250 M6	IE4-PE0R 225 M6	1000	50	45.0	430.00	537.00	360	94.9	0.98	78.0	0.0375	349	1.604	0.529	0.504	0.166	0.711	360	
IE4-PE1R 280 S6	IE4-PE0R 250 S6	1000	50	55.0	525.00	657.00	360	95.3	0.95	98.0	0.0335	334	1.656	0.538	0.520	0.169	1.142	465	
IE4-PE1R 280 M6	IE4-PE0R 250 M6	1000	50	75.0	716.00	895.00	367	95.5	0.97	128.0	0.0260	348	1.414	0.436	0.444	0.137	1.423	520	
IE4-PE1R 315 S6	IE4-PE0R 280 S6	1000	50	90.0	860.00	1074.00	358	95.8	0.95	160.0	0.0163	334	1.123	0.348	0.353	0.109	2.275	690	
IE4-PE1R 315 M6	IE4-PE0R 280 M6	1000	50	110.0	1050.00	1313.00	360	96	0.96	192.0	0.0120	341	0.908	0.266	0.285	0.084	2.875	800	
IE4-PE1R 315 MX6	IE4-PE0R 315 S6	1000	50	132.0	1261.00	1576.00	371	96.2	0.97	221.0	0.0116	356	0.910	0.262	0.286	0.082	3.110	890	
IE4-PE1R 315 MY6	IE4-PE0R 315 M6	1000	50	160.0	1528.00	1910.00	368	96.3	0.97	269.0	0.0076	353	0.717	0.181	0.225	0.057	5.285	1050	
IE4-PE1R 315 L6	IE4-PE0R 315 L6	1000	50	200.0	1273.00	1592.00	365	96.4	0.96	342.0	0.0063	347	0.612	0.151	0.192	0.047	5.940	1250	
IE4-PE1R 315 LX6	IE4-PE0R 315 LX6	1000	50	250.0	1592.00	1990.00	362	96.5	0.95	435.0	0.0043	340	0.451	0.106	0.142	0.033	7.644	1460	

Permanent-magnet synchronous motors for converter-fed operation Series P2.R, high-power motors

Increased output, with surface cooling, Type of cooling IC 411
Thermal class 155[F/B], degree of protection IP 55

Motor selection data												Converter input voltage 400 V, 50 Hz							
		Speed	Frequency	Rated output	Torque	Max. torque (2 min)	Voltage	Efficiency	Power factor	Rated current	Phase resistance at 20 °C	No-load voltage at 1000 rpm	Magnetising inductance	Leakage inductance	Magnetising reactance	Leakage reactance	Motor moment of inertia	Motor mass	
		rpm	Hz	[kW]	[Nm]	[Nm]	[V]	100%	[-]	[A]	R _{1 20} [Ω]	U _{P0 20} [V/1000 rpm]	L _{1H} [mH]	L _{1σ} [mH]	X _{1H} [Ω]	X _{1σ} [Ω]	J kgm ²	m kg	
Synchronous speed 3000 rpm – 4-pole version, rated frequency 100 Hz																			
P21R 63 K4	P20R 56 K4	3000	100	0.37	1.2	2.5	330	77.5	0.98	0.80	26	95	50	20	31.4	12.6	0.00019	4.8	
P21R 63 G4	P20R 56 G4	3000	100	0.55	1.8	3.5	334	78	0.98	1.20	17	100	35	15	22.0	9.4	0.00024	5.2	
P21R 71 K4	P20R 63 K4	3000	100	0.75	2.4	4	330	77.0	0.98	1.74	11.5	100	30	13	18.8	8.2	0.00040	6.8	
P21R 71 G4	P20R 63 G4	3000	100	1.10	3.5	7	320	78.0	0.98	2.50	7.5	93	25	10	15.7	6.3	0.00050	7.8	
P21R 80 K4	P20R 71 K4	3000	100	1.50	4.8	10	320	81.0	0.98	3.20	4.5	100	21	6	13.2	3.8	0.00087	10.6	
P21R 80 G4	P20R 71 G4	3000	100	2.2	7.0	14	310	90.0	0.96	4.70	2.4	100	15	5	9.4	3.1	0.00107	11.7	
P21R 90 S4	P20R 80 K4	3000	100	3.0	9.5	19	325	86.3	0.98	6.30	1.7	105	9.5	2.5	6.0	1.6	0.00207	15.5	
P21R 90 L4	P20R 80 G4	3000	100	4.0	12.7	28	290	87.4	0.98	9.30	0.8	90	5	1	3.1	0.6	0.00260	18.0	
P21R 100 L4	P20R 90 L4	3000	100	5.5	17.5	45	320	92.9	0.98	10.90	0.6	100	4.7	1.3	3.0	0.8	0.00400	23.5	
P21R 112 MY4	P20R 100 S4	3000	100	7.5	23.9	50	330	93.3	0.99	14.20	0.4	110	3.2	0.8	2.0	0.5	0.00725	31.0	
P21R 132 M4	P20R 132 S4	3000	100	15	48	60.0	357	90.3	0.99	27.1	0.1	117	1.682	0.738	1.056	0.463	0.024	72	
P21R 160 M4	P20R 132 M4	3000	100	18.5	59.0	74.0	366	90.9	0.99	32.4	0.059	120	1.207	0.485	0.758	0.305	0.033	92	
P21R 160 L4	P20R 160 S4	3000	100	22	70.0	88.0	362	91.3	0.99	38.8	0.037	119	1.187	0.398	0.745	0.25	0.065	120	
P21R 180 M4	P20R 160 M4	3000	100	30	96.0	120.0	358	92	0.99	53.0	0.032	117	1.003	0.327	0.63	0.205	0.076	135	
P21R 180 L4	P20R 180 S4	3000	100	37	118.0	148.0	367	92.5	0.99	64.0	0.021	121	0.811	0.267	0.509	0.168	0.126	170	
P21R 200 L4	P20R 180 M4	3000	100	45	143.0	179.0	359	92.9	0.99	79.0	0.0138	118	0.577	0.176	0.362	0.111	0.162	200	
P21R 225 S4	P20R 200 M4	3000	100	55	175.0	219.0	358	93.2	1	95.0	0.00865	119	0.536	0.153	0.337	0.096	0.264	270	
P21R 225 M4	P20R 200 L4	3000	100	75	239.0	299.0	362	93.8	0.99	129.0	0.0073	119	0.457	0.125	0.287	0.0785	0.303	300	
P21R 250 M4	P20R 225 M4	3000	100	90	287.0	359.0	363	94.1	1	152.0	0.0053	121	0.378	0.104	0.237	0.0653	0.485	375	
P21R 280 S4	P20R 250 S4	3000	100	110	350.0	438.0	371	94.3	1	182.0	0.0035	124	0.317	0.076	0.199	0.0477	0.911	520	
P21R 280 M4	P20R 250 M4	3000	100	132	420.0	525.0	373	94.6	1	216.0	0.0029	126	0.269	0.063	0.169	0.0396	1.065	580	
P21R 315 S4	P20R 280 S4	3000	100	160	509.0	636.0	371	94.8	1	263.0	0.00623	124	0.672	0.14	0.422	0.0879	1.75	740	
P21R 315 M4	P20R 280 M4	3000	100	200	637.0	796.0	365	95	1	333.0	0.0046	121	0.546	0.108	0.343	0.0678	1.75	840	
Synchronous speed 1500 rpm – 4-pole version, rated frequency 50 Hz																			
P21R 63 K4	P20R 56 K4	1500	50	0.18	1.1	2.5	340	73.0	0.98	0.45	95	170	160	80	50.3	25.1	0.00019	4.8	
P21R 63 G4	P20R 56 G4	1500	50	0.25	1.6	3.5	330	77.5	0.98	0.57	57	180	130	60	40.8	18.9	0.00024	5.2	
P21R 71 K4	P20R 63 K4	1500	50	0.3	1.9	4.0	315	66.5	0.98	0.75	44	165	110	50	34.6	15.7	0.0004	6.8	
P21R 71 G4	P20R 63 G4	1500	50	0.5	3.2	7.0	340	75.0	0.98	1.40	27	175	85	35	26.7	11.0	0.00050	7.8	
P21R 80 K4	P20R 71 K4	1500	50	0.75	4.8	10.0	325	80.6	0.99	1.75	14.5	190	76	24	23.9	7.5	0.00087	10.6	
P21R 80 G4	P20R 71 G4	1500	50	1.1	7.0	14.0	330	82.7	0.99	2.35	9.5	195	61	19	19.2	6.0	0.00107	11.7	
P21R 90 S4	P20R 80 K4	1500	50	1.5	9.5	19.0	330	81.1	0.98	3.30	6	195	36	9	11.3	2.8	0.00207	15.5	
P21R 90 L4	P20R 80 G4	1500	50	2.2	14.0	28.0	320	85.3	0.97	4.80	3.4	190	24.5	5.5	7.7	1.7	0.00260	18.0	
P21R 100 L4	P20R 90 L4	1500	50	3	325.0	45.0	325	87.7	0.98	6.20	2.1	195	15.5	4.5	4.9	1.4	0.00400	23.5	
P21R 100 LX4	P20R 100 S4	1500	50	4	25.5	50.0	320	89.1	0.97	8.35	1.4	200	16.0	4.0	5.0	1.3	0.00725	30.0	
P21R 112 M4	P20R 100 L4	1500	50	5.5	35.0	85.0	325	91.5	0.98	10.90	0.9	205	10.5	2.5	3.3	0.8	0.009	37.0	
P21R 132 S4T	P20R 100 LX4	1500	50	7.5	47.7	100.0	330	91.7	0.98	14.60	0.65	210	8.2	1.8	2.6	0.6	0.011	47.0	
P21R 132 M4	P20R 132 S4	1500	50	11	70.0	88.0	361	89.8	0.99	19.8	0.359	230	6.59	2.85	2.069	0.895	0.024	70	
P21R 160 M4	P20R 132 M4	1500	50	15	96.0	120	364	90.6	0.99	26.5	0.204	236	4.63	1.85	1.454	0.581	0.033	92	
P21R 160 L4	P20R 160 S4	1500	50	18.5	118	148	363	91.2	0.99	32.6	0.125	236	3.90	1.37	1.225	0.43	0.068	120	
P21R 180 M4	P20R 160 M4	1500	50	22	140	175	363	91.6	0.99	38.6	0.096	236	3.27	0.99	1.027	0.311	0.079	136	
P21R 180 L4	P20R 180 S4	1500	50	30	191	239	362	92.3	0.98	53.0	0.0742	233	2.98	0.969	0.934	0.304	0.126	170	
P21R 200 L4	P20R 180 M4	1500	50	37	236	295	363	92.7	0.99	64.0	0.05	236	2.35	0.704	0.736	0.221	0.162	200	
P21R 225 S4	P20R 200 M4	1500	50	45	287	359	361	93.1	0.99	78.0	0.029	239	1.94	0.558	0.61	0.175	0.269	270	
P21R 225 M4	P20R 200 L4	1500	50	55	350	438	356	93.5	0.99	96.0	0.024	234	1.63	0.45	0.513	0.141	0.308	300	
P21R 250 M4	P20R 225 M4	1500	50	75	478	598	363	94	0.99	128.0	0.0173	238	1.33	0.37	0.416	0.116	0.492	380	
P21R 280 S4	P20R 250 S4	1500	50	90	573	716	359	94.2	0.99	155.0	0.0106	237	1.00	0.242	0.315	0.076	0.935	535	
P21R 280 M4	P20R 250 M4	1500	50	110	700	875	360	94.5	0.99	189.0	0.00825	238	0.82	0.189	0.257	0.0593	1.089	600	
P21R 315 S4	P20R 280 S4	1500	50	132	840	1050	362	94.7	0.99	225.0	0.00628	241	0.72	0.155	0.226	0.0487	1.79	740	
P21R 315 S4	P20R 280 M4	1500	50	160	1019	1274	363	94.9	0.99	271.0	0.00509	239	0.59	0.1223	0.186	0.0384	2.071	840	
P21R 315 MX4	P20R 315 S4	1500	50	200	1273	1591	361	95.1	0.99	340.0	0.00384	238	0.42	0.0994	0.131	0.0312	2.406	1000	
P21R 315 MY4	P20R 315 M4	1500	50	250	1592	1990	361	95.1	0.99	425.0	0.00359	237	0.39	0.0776	0.122	0.0244	4.224	1200	
P21R 315 L4	P20R 315 L4	1500	50	315	2006	2508	619	95.1	0.99	312.0	0.00763	409	0.91	0.171	0.284	0.0537	5.273	1450	

Permanent-magnet synchronous motors for converter-fed operation
Series P2.R, high-power motors

Increased output, with surface cooling, Type of cooling IC 411
 Thermal class 155[F/B], degree of protection IP 55

Motor selection data												Converter input voltage 400 V, 50 Hz							
		Speed	Frequency	Rated output	Torque	Max. torque (2 min)	Voltage	Efficiency	Power factor	Rated current	Phase resistance at 20 °C	No-load voltage at 1000 rpm	Magnetising inductance	Leakage inductance	Magnetising reactance	Leakage reactance	Motor moment of inertia	Motor mass	
		rpm	Hz	[kW]	[Nm]	[Nm]	[V]	100%	[-]	[A]	R_{120}	U_{p020}	L_{1H}	$L_{1\sigma}$	X_{1H}	$X_{1\sigma}$	J	m	
Synchronous speed 1000 rpm – 6-pole version, rated frequency 50 Hz																			
P21R 132 M6	P20R 112 MX6	1000	50	5.5	53	66	353	86.5	1	10.4	0.991	344	7.75	4.02	2.434	1.262	0.021	53	
P21R 132 MX6	P20R 132 S6	1000	50	7.5	72	90	362	88.5	0.99	13.7	0.501	348	6.64	3.072	2.084	0.965	0.04	70	
P21R 160 M6	P20R 132 M6	1000	50	11	105	131	359	90.2	0.99	19.8	0.348	342	4.69	2.177	1.472	0.684	0.052	86	
P21R 160 L6	P20R 160 S6	1000	50	15	143	179	360	91	1	26.4	0.252	356	4.76	1.796	1.494	0.564	0.103	114	
P21R 180 L6	P20R 160 M6	1000	50	18.5	177	221	360	91.5	0.99	32.8	0.168	347	3.40	1.217	1.067	0.382	0.135	136	
P21R 200 L6	P20R 180 S6	1000	50	22	210	263	354	92	1	39.0	0.103	347	3.00	1.026	0.942	0.322	0.223	175	
P21R 200 LX6	P20R 180 M6	1000	50	30	287	359	359	92.7	0.99	53.0	0.077	351	2.33	0.784	0.733	0.246	0.27	200	
P21R 225 M6	P20R 200 M6	1000	50	37	353	441	361	93.1	0.99	64.0	0.054	352	1.92	0.61	0.602	0.192	0.437	265	
P21R 250 M6	P20R 225 M6	1000	50	45	430	538	360	93.5	0.99	78.0	0.038	351	1.45	0.49	0.455	0.154	0.721	360	
P21R 280 S6	P20R 250 S6	1000	50	55	525	656	362	93.9	1	93.0	0.026	360	1.25	0.412	0.394	0.129	1.198	465	
P21R 280 M6	P20R 250 M6	1000	50	75	716	895	362	94.1	0.99	128.0	0.0204	357	0.95	0.297	0.297	0.0933	1.492	520	
P21R 315 S6	P20R 280 S6	1000	50	90	860	1075	359	94.3	0.99	155.0	0.014	353	0.99	0.29	0.311	0.0911	2.367	690	
P21R 315 M6	P20R 280 M6	1000	50	110	1051	1314	363	94.9	0.99	186.0	0.0119	362	0.81	0.23	0.255	0.0722	2.981	800	
P21R 315 MX6	P20R 315 S6	1000	50	132	1261	1576	358	95.2	0.98	228.0	0.0086	350	0.70	0.192	0.22	0.0603	3.226	880	
P21R 315 MY6	P20R 315 M6	1000	50	160	1528	1910	362	95.4	0.98	273.0	0.00759	358	0.69	0.181	0.216	0.0568	5.334	1050	
P21R 315 L6	P20R 315 L6	1000	50	200	1910	2388	361	95.6	0.97	345.0	0.0058	347	0.55	0.137	0.173	0.043	5.995	1250	
P21R 315 LX6	P20R 315 LX6	1000	50	250	2388	2985	363	95.6	0.99	420.0	0.0043	359	0.45	0.106	0.142	0.0333	7.714	1450	
Synchronous speed 750 rpm – 8-pole version, rated frequency 50 Hz																			
P21R 160 M8	P20R 132 S8	750	50	5.5	70	88	358	84.6	0.99	10.6	0.747	452	5.30	4.223	1.665	1.326	0.042	70	
P21R 160 MX8	P20R 132 M8	750	50	7.5	96	120	361	86.5	0.99	14.0	0.515	459	4.15	3.231	1.302	1.015	0.054	86	
P21R 160 L8	P20R 160 S8	750	50	11	140	175	362	87.5	0.99	20.3	0.326	459	4.77	2.11	1.499	0.663	0.106	114	
P21R 180 L8	P20R 160 M8	750	50	15	191	239	358	88.7	0.99	27.5	0.381	446	3.07	2.68	0.964	0.842	0.138	136	
P21R 200 L8	P20R 180 S8	750	50	18.5	236	295												175	
P21R 200 LX8	P20R 180 M8	750	50	22	280	350												200	
P21R 225 M8	P20R 200 M8	750	50	30	382	478	360	90.5	0.98	54.0	0.0815	459	1.83	0.897	0.576	0.282	0.439	265	
P21R 250 M8	P20R 225 M8	750	50	37	471	589												0.439	360

Terminal boxes, bearings and dimensions

The permanent-magnet synchronous motors IE4-PE.R are identical to the series K21R/WE.R.
For further information regarding the terminal boxes, bearings and dimensions, please refer to Chapter 2.

Assignment table					
Type		Type	Type	J	m
PE.R		K21R	K20R	kgm ²	kg
Synchronous speed 3000 rpm – 4-pole version, rated frequency 100 Hz					
IE4-PE1R 63 K4	IE4-PE0R 56 K4	K21R 63 K2	K20R 56 K2	0.00019	4.8
IE4-PE1R 63 G4	IE4-PE0R 56 G4	K21R 63 G2	K20R 56 G2	0.00019	4.8
IE4-PE1R 63 G4	IE4-PE0R 56 G4	K21R 63 G2	K20R 56 G2	0.00024	5.2
IE4-PE1R 71 K4	IE4-PE0R 63 K4	K21R 71 K2	K20R 63 K2	0.00040	6.8
IE4-PE1R 71 G4	IE4-PE0R 63 G4	K21R 71 G2	K20R 63 G2	0.00050	7.8
IE4-PE1R 80 K4	IE4-PE0R 71 K4	K21R 80 K2	K20R 71 K2	0.00087	10.6
IE4-PE1R 80 G4	IE4-PE0R 71 G4	K21R 80 G2	K20R 71 G2	0.00107	11.7
IE4-PE1R 90 S4	IE4-PE0R 80 K4	K21R 90 S2	K20R 80 K2	0.00207	15.5
IE4-PE1R 90 L4	IE4-PE0R 80 G4	K21R 90 L2	K20R 80 G2	0.00260	18.0
IE4-PE1R 100 L4	IE4-PE0R 90 L4	K21R 100 L2	K20R 90 L2	0.00400	23.5
IE4-PE1R 112 MY4	IE4-PE0R 100 S4	K21R 112 M2	K20R 100 S2	0.00725	31.0
IE4-PE1R 132 SY4T	IE4-PE0R 100 L4	K21R 132 ST	K20R 100 L2	0.0090	39.0
IE4-PE1R 132 S4T	IE4-PE0R 100 LX4	K21R 132 SX2T	K20R 100 LX2	0.0110	47.0
IE4-PE1R 132 M4	IE4-PE0R 132 S4	K21R 132 M4	K20R 132 S4	0.022	72
IE4-PE1R 132 M4	IE4-PE0R 132 S4	K21R 132 M4	K20R 132 S4	0.022	72
IE4-PE1R 160 M4	IE4-PE0R 132 M4	K21R 160 M4	K20R 132 M4	0.031	92
IE4-PE1R 160 L4	IE4-PE0R 160 S4	K21R 160 L4	K20R 160 S4	0.062	121
IE4-PE1R 180 M4	IE4-PE0R 160 M4	K21R 180 M4	K20R 160 M4	0.079	135
IE4-PE1R 180 M4	IE4-PE0R 160 M4	K21R 180 M4	K20R 160 M4	0.079	135
IE4-PE1R 180 L4	IE4-PE0R 180 S4	K21R 180 L4	K20R 180 S4	0.116	170
IE4-PE1R 200 L4	IE4-PE0R 180 M4	K21R 200 L4	K20R 180 M4	0.150	200
IE4-PE1R 225 S4	IE4-PE0R 200 M4	K21R 225 S4	K20R 200 M4	0.251	270
IE4-PE1R 225 M4	IE4-PE0R 200 L4	K21R 225 M4	K20R 200 L4	0.288	300
IE4-PE1R 250 M4	IE4-PE0R 225 M4	K21R 250 M4	K20R 225 M4	0.457	375
IE4-PE1R 250 M4	IE4-PE0R 225 M4	K21R 250 M4	K20R 225 M4	0.457	375
IE4-PE1R 280 S4	IE4-PE0R 250 S4	K21R 280 S4	K20R 250 S4	0.864	520
IE4-PE1R 280 S4	IE4-PE0R 250 S4	K21R 280 S4	K20R 250 S4	0.864	520
IE4-PE1R 280 M4	IE4-PE0R 250 M4	K21R 280 M4	K20R 250 M4	1.011	580
IE4-PE1R 315 MX4	IE4-PE0R 315 S4	K21R 315 MX4	K20R 315 S4	1.556	980
IE4-PE1R 315 MY4	IE4-PE0R 315 M4	K21R 315 MY4	K20R 315 M4	2.50	1170
Synchronous speed 1500 rpm – 4-pole version, rated frequency 50 Hz					
IE4-PE1R 63 K4	IE4-PE0R 56 K4	K21R 63 K4	K20R 56 K4	0.00019	4.8
IE4-PE1R 63 G4	IE4-PE0R 56 G4	K21R 63 G4	K20R 56 G4	0.00024	5.2
IE4-PE2R 71 K4	-	-	IE2-W21R 71 K4	0.00087	9.9
IE4-PE2R 71 G4	-	-	IE2-W21R 71 G4	0.00107	11.0
IE4-PE2R 80 K4	-	K21R 80 G4	-	0.00107	11.7
IE4-PE2R 80 G4	-	-	IE2-W21R 80 K4	0.00207	14.5
IE4-PE2R 90 S4	-	-	IE2-WE2R 90 S4	0.00260	18.0
IE4-PE1R 90 L4	IE4-PE0R 80 G4	K21R 90 L4	K20R 80 G4	0.00260	18.0
IE4-PE1R 100 L4	IE4-PE0R 90 L4	K21R 100 L4	K20R 90 L4	0.00400	23.5
IE4-PE1R 100 LX4	IE4-PE0R 100 S4	K21R 100 LX4	K20R 100 S4	0.00725	30
IE4-PE1R 112 M4	IE4-PE0R 100 L4	K21R 112 M4	K20R 100 L4	0.0090	37
IE4-PE1R 132 S4T	IE4-PE0R 100 LX4	K21R 132 S4T	K20R 100 LX4	0.0110	47
IE4-PE1R 132 M4	IE4-PE0R 132 S4	K21R 132 M4	K20R 132 S4	0.02	70
IE4-PE1R 160 M4	IE4-PE0R 132 M4	K21R 160 M4	K20R 132 M4	0.03	92
IE4-PE1R 160 L4	IE4-PE0R 160 S4	K21R 160 L4	K20R 160 S4	0.07	120
IE4-PE1R 180 M4	IE4-PE0R 160 M4	K21R 180 M4	K20R 160 M4	0.07	136
IE4-PE1R 180 L4	IE4-PE0R 180 S4	K21R 180 L4	K20R 180 S4	0.13	170
IE4-PE1R 200 L4	IE4-PE0R 180 M4	K21R 200 L4	K20R 180 M4	0.16	220
IE4-PE1R 225 S4	IE4-PE0R 200 M4	K21R 225 S4	K20R 200 M4	0.27	270
IE4-PE1R 225 M4	IE4-PE0R 200 L4	K21R 225 M4	K20R 200 L4	0.31	300
IE4-PE1R 250 M4	IE4-PE0R 225 M4	K21R 250 M4	K20R 225 M4	0.49	375
IE4-PE1R 250 M4	IE4-PE0R 225 M4	K21R 250 M4	K20R 225 M4	0.49	375
IE4-PE1R 280 S4	IE4-PE0R 250 S4	K21R 280 S4	K20R 250 S4	0.91	520
IE4-PE1R 280 M4	IE4-PE0R 250 M4	K21R 280 M4	K20R 250 M4	1.07	580
IE4-PE1R 280 M4	IE4-PE0R 250 M4	K21R 280 M4	K20R 250 M4	1.09	580
IE4-PE1R 315 S4	IE4-PE0R 280 S4	K21R 315 S4	K20R 280 S4	1.75	740
IE4-PE1R 315 MX4	IE4-PE0R 315 S4	K21R 315 MX4	K20R 315 S4	2.35	1000
IE4-PE1R 315 MY4	IE4-PE0R 315 M4	K21R 315 MY4	K20R 315 M4	4.22	1200

The permanent-magnet synchronous motors P21R are identical to the series K21R.
For further information regarding the terminal boxes, bearings and dimensions, please refer to Chapter 2.

Assignment table					
Type	Type	Type	J	m	
PE.R	K21R	K20R	kgm ²	kg	
Synchronous speed 1000 rpm – 6-pole version, rated frequency 50 Hz					
IE4-PE1R 132 MX6	IE4-PE0R 132 S6	K21R 132 MX6	K20R 132 S6	0.040	70
IE4-PE1R 160 M6	IE4-PE0R 132 M6	K21R 160 M6	K20R 132 M6	0.052	86
IE4-PE1R 160 L6	IE4-PE0R 160 S6	K21R 160 L6	K20R 160 S6	0.104	114
IE4-PE1R 180 L6	IE4-PE0R 160 M6	K21R 180 L6	K20R 160 M6	0.135	136
IE4-PE1R 180 L6	IE4-PE0R 160 M6	K21R 180 L6	K20R 160 M6	0.135	136
IE4-PE1R 200 L6	IE4-PE0R 180 S6	K21R 200 L6	K20R 180 S6	0.219	175
IE4-PE1R 200 LX6	IE4-PE0R 180 M6	K21R 200 LX6	K20R 180 M6	0.270	200
IE4-PE1R 225 M6	IE4-PE0R 200 M6	K21R 225 M6	K20R 200 M6	0.437	265
IE4-PE1R 250 M6	IE4-PE0R 225 M6	K21R 250 M6	K20R 225 M6	0.711	360
IE4-PE1R 280 S6	IE4-PE0R 250 S6	K21R 280 S6	K20R 250 S6	1.142	465
IE4-PE1R 280 M6	IE4-PE0R 250 M6	K21R 280 M6	K20R 250 M6	1.423	520
IE4-PE1R 315 S6	IE4-PE0R 280 S6	K21R 315 S6	K20R 280 S6	2.275	690
IE4-PE1R 315 M6	IE4-PE0R 280 M6	K21R 315 M6	K20R 280 M6	2.875	800
IE4-PE1R 315 MX6	IE4-PE0R 315 S6	K21R 315 MX6	K20R 315 S6	3.110	890
IE4-PE1R 315 MY6	IE4-PE0R 315 M6	K21R 315 MY6	K20R 315 M6	5.285	1050
IE4-PE1R 315 L6	IE4-PE0R 315 L6	K21R 315 L6	K20R 315 L6	5.940	1250
IE4-PE1R 315 LX6	IE4-PE0R 315 LX6	K21R 315 LX6	K20R 315 LX6	7.644	1460

The permanent-magnet synchronous motors P21R are identical to the series K21R.
For further information regarding the terminal boxes, bearings and dimensions, please refer to Chapter 2.

Assignment table

Type	Type	J	m		
P21R	K21R	kgm ²	kg		
Synchronous speed 3000 rpm – 4-pole version, rated frequency 100 Hz					
P21R 63 K4	P20R 56 K4	K21R 63 K2	K20R 56 K2	0.00019	4.8
P21R 63 G4	P20R 56 G4	K21R 63 G2	K20R 56 G2	0.00024	5.2
P21R 71 K4	P20R 63 K4	K21R 71 K2	K20R 63 K2	0.00040	6.8
P21R 71 G4	P20R 63 G4	K21R 71 G2	K20R 63 G2	0.00050	7.8
P21R 80 K4	P20R 71 K4	K21R 80 K2	K20R 71 K2	0.00087	10.6
P21R 80 G4	P20R 71 G4	K21R 80 G2	K20R 71 G2	0.00107	11.7
P21R 90 S4	P20R 80 K4	K21R 90 S2	K20R 80 K2	0.00207	15.5
P21R 90 L4	P20R 80 G4	K21R 90 L2	K20R 80 G2	0.00260	18.0
P21R 100 L4	P20R 90 L4	K21R 100 L2	K20R 90 L2	0.00400	23.5
P21R 112 MY4	P20R 100 S4	K21R 112 M2	K20R 100 S2	0.00725	31.0
P21R 132 M4	P20R 132 S4	K21R 132 M4	K20R 132 S4	0.024	72
P21R 160 M4	P20R 132 M4	K21R 160 M4	K20R 132 M4	0.033	92
P21R 160 L4	P20R 160 S4	K21R 160 L4	K20R 160 S4	0.065	120
P21R 180 M4	P20R 160 M4	K21R 180 M4	K20R 160 M4	0.076	135
P21R 180 L4	P20R 180 S4	K21R 180 L4	K20R 180 S4	0.126	170
P21R 200 L4	P20R 180 M4	K21R 200 L4	K20R 180 M4	0.162	200
P21R 225 S4	P20R 200 M4	K21R 225 S4	K20R 200 M4	0.264	270
P21R 225 M4	P20R 200 L4	K21R 225 M4	K20R 200 L4	0.303	300
P21R 250 M4	P20R 225 M4	K21R 250 M4	K20R 225 M4	0.485	375
P21R 280 S4	P20R 250 S4	K21R 280 S4	K20R 250 S4	0.911	520
P21R 280 M4	P20R 250 M4	K21R 280 M4	K20R 250 M4	1.065	580
P21R 315 S4	P20R 280 S4	K21R 315 S4	K20R 280 S4	1.75	740
P21R 315 M4	P20R 280 M4	K21R 315 M4	K20R 280 M4	1.75	840

Synchronous speed 1500 rpm – 4-pole version, rated frequency 50 Hz

P21R 63 K4	P20R 56 K4	K21R 63 K4	K20R 56 K4	0.00019	4.8
P21R 63 G4	P20R 56 G4	K21R 63 G4	K20R 56 G4	0.00024	5.2
P21R 71 K4	P20R 63 K4	K21R 71 K4	K20R 63 K4	0.00040	6.8
P21R 71 G4	P20R 63 G4	K21R 71 G4	K20R 63 G4	0.00050	7.8
P21R 80 K4	P20R 71 K4	K21R 80 K4	K20R 71 K4	0.00087	10.6
P21R 80 G4	P20R 71 G4	K21R 80 G4	K20R 71 G4	0.00107	11.7
P21R 90 S4	P20R 80 K4	K21R 90 S4	K20R 80 K4	0.00207	15.5
P21R 90 L4	P20R 80 G4	K21R 90 L4	K20R 80 G4	0.00260	18.0
P21R 100 L4	P20R 90 L4	K21R 100 L4	K20R 90 L4	0.00400	23.5
P21R 100 LX4	P20R 100 S4	K21R 100 LX4	K20R 100 S4	0.00725	30.0
P21R 112 M4	P20R 100 L4	K21R 112 M4	K20R 100 L4	0.0090	37.0
P21R 132 S4T	P20R 100 LX4	K21R 132 S4T	K20R 100 LX4	0.0110	47.0
P21R 132 M4	P20R 132 S4	K21R 132 M4	K20R 132 S4	0.02	70
P21R 160 M4	P20R 132 M4	K21R 160 M4	K20R 132 M4	0.03	92
P21R 160 L4	P20R 160 S4	K21R 160 L4	K20R 160 S4	0.07	120
P21R 180 M4	P20R 160 M4	K21R 180 M4	K20R 160 M4	0.08	136
P21R 180 L4	P20R 180 S4	K21R 180 L4	K20R 180 S4	0.13	170
P21R 200 L4	P20R 180 M4	K21R 200 L4	K20R 180 M4	0.16	200
P21R 225 S4	P20R 200 M4	K21R 225 S4	K20R 200 M4	0.27	270
P21R 225 M4	P20R 200 L4	K21R 225 M4	K20R 200 L4	0.31	300
P21R 250 M4	P20R 225 M4	K21R 250 M4	K20R 225 M4	0.49	380
P21R 280 S4	P20R 250 S4	K21R 280 S4	K20R 250 S4	0.94	535
P21R 280 M4	P20R 250 M4	K21R 280 M4	K20R 250 M4	1.09	600
P21R 315 S4	P20R 280S 4	K21R 315 S4	K20R 280S 4	1.79	740
P21R 315 S4	P20R 280M 4	K21R 315 S4	K20R 280M 4	2.07	840
P21R 315 MX4	P20R 315 S4	K21R 315 MX4	K20R 315 S4	2.41	1000
P21R 315 MY4	P20R 315 M4	K21R 315 MY4	K20R 315 M4	4.22	1200
P21R 315 L4	P20R 315 L4	K21R 315 L4	K20R 315 L4	5.27	1450

The permanent-magnet synchronous motors P21R are identical to the series K21R.
For further information regarding the terminal boxes, bearings and dimensions, please refer to Chapter 2.

Assignment table

Type	Type	J	m		
P21R	K21R	kgm ²	kg		
Synchronous speed 1000 rpm – 6-pole version, rated frequency 50 Hz					
P21R 132 MX6	P20R 132 S6	K21R 132 MX6	K20R 132 S6	0.040	70
P21R 160 M6	P20R 132 M6	K21R 160 M6	K20R 132 M6	0.052	86
P21R 160 L6	P20R 160 S6	K21R 160 L6	K20R 160 S6	0.103	114
P21R 180 L6	P20R 160 M6	K21R 180 L6	K20R 160 M6	0.135	136
P21R 200 L6	P20R 180 S6	K21R 200 L6	K20R 180 S6	0.223	175
P21R 200 LX6	P20R 180 M6	K21R 200 LX6	K20R 180 M6	0.270	200
P21R 225 M6	P20R 200 M6	K21R 225 M6	K20R 200 M6	0.437	265
P21R 250 M6	P20R 225 M6	K21R 250 M6	K20R 225 M6	0.721	360
P21R 280 S6	P20R 250 S6	K21R 280 S6	K20R 250 S6	1.198	465
P21R 280 M6	P20R 250 M6	K21R 280 M6	K20R 250 M6	1.492	520
P21R 315 S6	P20R 280 S6	K21R 315 S6	K20R 280 S6	2.367	690
P21R 315 M6	P20R 280 M6	K21R 315 M6	K20R 280 M6	2.981	800
P21R 315 MX6	P20R 315 S6	K21R 315 MX6	K20R 315 S6	3.226	880
P21R 315 MY6	P20R 315 M6	K21R 315 MY6	K20R 315 M6	5.334	1050
P21R 315 L6	P20R 315 L6	K21R 315 L6	K20R 315 L6	5.995	1250
P21R 315 LX6	P20R 315 LX6	K21R 315 LX6	K20R 315 LX6	7.714	1450
Synchronous speed 750 rpm – 8-pole version, rated frequency 50 Hz					
P21R 160 M8	P20R 132 S8	K21R 160 M8	K20R 132 S8	0.042	70
P21R 160 MX8	P20R 132 M8	K21R 160 MX8	K20R 132 M8	0.054	86
P21R 160 L8	P20R 160 S8	K21R 160 L8	K20R 160 S8	0.106	114
P21R 180 L8	P20R 160 M8	K21R 180 L8	K20R 160 M8	0.138	136
P21R 200 L8	P20R 180 S8	K21R 200 L8	K20R 180 S8		175
P21R 200 LX8	P20R 180 M8	K21R 200 LX8	K20R 180 M8		200
P21R 225 M8	P20R 200 M8	K21R 225 M8	K20R 200 M8	0.439	265
P21R 250 M8	P20R 225 M8	K21R 250 M8	K20R 225 M8	0.439	360



Asynchronous generators

Contents

Product description _____	13/2
Overview of technical data _____	13/3

Motor selection data

Series G4.R on the basis of Premium Efficiency IE3 _____	13/4
Series GE.R on the basis of High Efficiency IE2 _____	13/6
Series G2.R on the basis of Standard Efficiency IE1 _____	13/8

Terminal boxes

Identical to terminal boxes of standard motors
see Chapter 2

Bearings

Identical to bearings of standard motors
see Chapter 2

Dimensions

Identical to dimensions of standard motors
see Chapter 2 and assignment tables _____ 13/10

Product description

Past industrial development has always correlated closely with advances in large power systems. In the meantime, however, the focus is shifting increasingly towards environment-friendly and renewable energy sources, leading to the growing acceptance of power generation plants with low to medium outputs. Examples of renewable energy sources

are wind and hydro power, and these are preferred fields of application for the asynchronous generator. It is a reliable, cost-effective and low-maintenance alternative to a classic synchronous generator. Asynchronous generators are operated either in isolation or parallel to an already existing mains supply, depending on the individual application.

Asynchronous generators for mains-parallel operation

When a three-phase asynchronous motor is driven oversynchronously by a drive machine, the negative slip also results in reversal of the energy flow. The motor begins to act as a generator and supplies energy to the mains. In this case,

the generator draws the necessary reactive power from the mains and no additional excitation systems are necessary. The mains holds the voltage and frequency, and thus separate regulators are similarly not required.

Asynchronous generators for isolated operation

When asynchronous generators are operated in isolation, the excitation is achieved through parallel connection of a capacitor bank. The dimensioning is dependent on the generator output, the generator parameters and the connected consumers. This mode of operation is significantly

more complex than mains-parallel operation and is only chosen for smaller outputs. It must also be pointed out that a generator operating in isolation reacts sensitively to inductive consumers and to load and speed changes.

Explanation of the symbols used in the selection data

P_B	Electrical active power output in kW	Q_B	Reactive power consumption at full load in kVAR
P_{auf}	Mechanical power input in kW	J	Moment of inertia in kgm^2
S	Electrical apparent power output in kVA	m	Mass in kg
n	Speed in rpm	n	Max. mechanical limit speed in rpm
η	Efficiency in %	I_B	Rated generator current
$\cos \phi$	Power factor	I_A/I_B	Relative starting current (motor value)
M_K/M_B	Relative generator pull-out torque		

Certificates of conformity in accordance with VDE-AR-N 4105:2011-08

The VDE application guide VDE-AR-N 4105:2011-08 and the associated test standard DIN VDE V 0124-100:2012-07 are intended to facilitate the improved integration of decentralised generation systems such as co-generation plants, wind turbines, hydropower plants and photovoltaic systems. Since 01.07.2012, the application guide has been binding for all power generation systems connected to the low-voltage distribution network (see VDE infosheet on VDE AR-N 4105).

The following documents must be presented when registering generation systems:

Block diagram:

- All equipment of the generation system from the main feeder box
- Existing meters (e.g. for supply) and planned metering points (generation, feed-in)
- Protective devices
- Generating units, with number, type, output, planned conductor connection
- Provisions for power reduction or limitation

For the generation system:

- Application form G.1 as per VDE-AR-N 4105
- Data sheet F.2 as per VDE-AR-N 4105 (separate data sheet for each generating unit [type])

For each generating unit:

- Certificate of conformity G.2 as per VDE-AR-N 4105
- Corresponding test report F.3 as per VDE-AR-N 4105

For the mains and system protection:

- Description of protective devices in accordance with section 6 of VDE-AR-N 4105
- Certificate of conformity G.3 as per VDE-AR-N 4105
- Corresponding test report F.4 as per VDE-AR-N 4105

Generation and mains security management:

Description of the implementation of section 5.7.3.2 of VDE-AR-N 4105 or § 6 EEG (where applicable)

It is the responsibility of the generation system operator to provide the above documents. In this context, it must be taken into account that an asynchronous generator must not be operated on the mains without appropriate control and regulation provisions and is also not to be viewed as a generating unit. The measurements required to be able to produce test reports F.3 und F.4 must be performed on the complete generation system. VEM motors – here purely a component manufacturer – provides performance characteristics, short-circuit characteristics and temperature-rise documentation.

All tests required in accordance with VDE application guide VDE-AR-N 4105:2011-08 must be performed on the complete generation system (generating unit).

In Germany, corresponding test services are offered by VDE Prüf- und Zertifizierungsinstitut GmbH.

Overview of technical data

The most important technical data are summarised in the following table. Further information can be taken from the catalogue section "introduction" (chapter 1).

Product group	Squirrel-cage rotor, IEC/EN
Rated output	5.5 to 710 kW
Sizes	132 to 400
Housing material	Grey cast iron
Rated torque	0.4 to 5800 Nm
Efficiency classification/ efficiency determination	IEC/EN 60034-30-1 / IEC/EN 60034-2-1, ≤ 1 kW direct measurement, > 1 kW residual loss method
Method of connection	Single-speed motors are designed in Δ/Y configuration as standard.
Stator winding insulation	Thermal class 155, optional 155 [F(B)], 180 to IEC/EN 60034-1
Degree of protection	IP 55 to IEC/EN 60034-5
Type of cooling	IC 411, IC 416, IC 71W (IC 31W) to IEC/EN 60034-6
Coolant temperature/ installation altitude	Standard -20 °C to +40 °C, Altitude 1000 m above sea level
Rated voltage	Standard voltages to EN 60038 50 Hz: 230 V, 400 V, 500 V, 690 V 60 Hz: 275 V, 460 V, 480 V, 600 V Voltage ranges A and B to IEC/EN 60034-1 (Prior consultation necessary regarding 230 V, 50 Hz and 275 V, 60 Hz for motors from size 315)
Duty types	S1, continuous duty Short-time duty S2, 10/30/60 min Duty type S3/S6, 25/40/60 %c.d.f.
Types of construction	IM B3, IM B35, IM B5 and derived types to IEC/EN 60034-7
Paint finish	Normal finish "Moderate", colour RAL 7031, blue-grey Special finish "Worldwide", colour RAL 7031, blue-grey
Vibration severity grade	Grade "A" as standard for machines with no special vibration requirements
Shaft ends	to DIN 748 (IEC 60072), balanced with half-key
Limit speeds	Please refer to the section of "Limit speeds" in catalogue section "Motors for converter-fed operation", Chapter 4.
Bearing design	Please refer to the tables of "Bearing design data" in catalogue section "Standard motors", Chapter 2.
Motor mass	Please refer to the technical selection lists.
Terminal boxes	Please refer to the section "Terminal boxes" in catalogue section "Standard motors", Chapter 2.
Documentation	An operating and maintenance manual, a terminal plan and a safety data sheet are supplied with each motor.
Tolerances	Please refer to the section "Tolerances" in catalogue section "Introduction", Chapter 1.
Options	Please refer to the section "Overview of modifications" in the catalogue section "Introduction", Chapter 1.

Motor selection data

Energy-optimised three-phase asynchronous generators

Active components, design for optimised efficiency based on Premium Efficiency IE3

Surface cooling, type of cooling IC 411, duty type S1, continuous duty,
thermal class 155 (F), degree of protection IP 55

Motor selection data														
Type	P _B	M _B	P _{auf}	S	n	η	cosφ _B	I _B	I _K /I _B	M _K /M _B	Q _n	n _{max}	J	m
IEC/DIN	kW	Nm	kW	kVA	rpm	%	-	A	-	-	kVAr	-	kgm ²	kg
Synchronous speed 1500 rpm – 4-pole version														
G41R 132 S4	5.5	34	6.1	6.6	1530	90.6	0.83	9.6	7.9	5.4	3.6	3600	0.035	90
G41R 132 M4	7.5	47	8.3	9.1	1530	90.9	0.82	13	8.3	5.5	5.2	3600	0.043	100
G41R 160 M4	11.0	69	12.2	13.4	1530	90.5	0.82	19.5	6.9	4.2	7.7	3000	0.078	125
G41R 160 L4	15.0	95	16.5	18.3	1515	91	0.82	26.5	10	5.4	10.5	3000	0.1567	175
G41R 180 M4	18.5	116	19.8	22.3	1520	93.4	0.83	32	7.8	4.2	12.5	3000	0.168	210
G41R 180 L4	22.0	138	23.7	26.5	1524	92.9	0.83	38.5	7.3	3.3	14.8	3000	0.203	240
G41R 200 L4	30.0	189	31.8	36.1	1512	94.2	0.83	52	7.2	3.5	20.1	3000	0.411	327
G41R 225 S4	37.0	233	39.6	43.5	1518	93.4	0.85	63	6.6	3.1	22.9	3000	0.4675	367
G41R 225 M4	45.0	284	47.6	53.6	1515	94.6	0.84	77.5	7.9	3.3	29.1	3000	0.619	450
G41R 250 M4	55.0	347	57.9	65.5	1514	95	0.84	94.5	7.6	2.6	35.6	3000	0.95	550
G41R 280 S4	75.0	474	78.7	90.4	1512	95.3	0.83	130	8.4	3.2	50.5	3000	1.1	605
G41R 280 M4	90.0	568	94.4	110	1512	95.3	0.82	158	8.8	3	63.0	3000	1.96	785
G41R 315 S4	110.0	694	115	138	1513	95.7	0.8	198	9.8	3.6	83.0	3000	1.96	760
G41R 315 M4	132.0	835	138	163	1510	95.5	0.81	235	8.5	3.2	96.0	3000	2.27	850
G42R 315 MX4	160.0	1013	167	190	1508	95.6	0.84	275	7.7	2.7	102	3000	4.02	1070
G41R 315 MY4	200.0	1263	208	235	1512	96	0.85	340	9.8	3.6	123	3000	4.82	1250
G41R 315 L4	250.0	1580	261	284	1511	95.8	0.88	410	8.8	3	135	3000	5.93	1450
G41R 315 LX4	315.0	1992	329	362	1510	95.7	0.87	523	10	3.4	178	3000	6.82	1630
G41R 355 M4	355.0	2247	368	413	1509	96.5	0.86	596	6.8	3.1	211	3000	7.90	2150
G42R 355 MX4	400.0			465								3000	9.5	2400
G42R 355 L4	500.0			559								3000	10	2500
Synchronous speed 1000 rpm – 6-pole version														
G41R 132 S6	3.0			4.0								2400	0.029	70
G41R 132 M6	4.0	37	4.6	5.4	1030	87	0.74	7.8	4.9	3.7	3.6	2400	0.043	75
G41R 132 MX6	5.5	51	6.2	7.4	1025	89	0.74	10.5	6	4.6	5	2400	0.053	105
G41R 160 M6	7.5	70	8.4	9.5	1025	89.5	0.79	13.5	5.8	3.7	5.8	2000	0.145	145
G41R 160 L6	11.0	103	12	12.6	1015	91.5	0.87	18	7.2	3.9	6.1	2000	0.166	168
G41R 180 L6	15.0	141	16.4	18.1	1013	91.7	0.83	26	7.0	3.9	10.1	2000	0.3396	214
G41R 200 L6	18.5	174	20.2	21.5	1018	91.6	0.86	31	7.2	4.1	11	2000	0.514	310
G41R 200 LX6	22.0	208	23.7	25.0	1010	92.7	0.88	36	8.5	5	11.9	2000	0.6476	321
G41R 225 M6	30.0	282	32.3	34.9	1016	92.9	0.86	50.5	7.7	3.9	17.8	2000	0.92	400
G41R 250 M6	37.0	349	39.8	43.0	1013	93	0.86	62.0	6.9	3.1	21.9	2000	1.48	545
G41R 280 S6	45.0	427	48	54.0	1006	93.5	0.84	77.5	9	3.8	30.0	2000	2.63	695
G41R 280 M6	55.0	521	58	65.0	1008	94.1	0.84	95	9.5	4.3	35.0	2000	3.33	815
G42R 315 S6	75.0	713	79	93.0	1005	94.5	0.81	134	8.5	3.5	55	2000	5.55	1060
G41R 315 M6	90.0	855	95	110.0	1005	95	0.82	158	8.8	3.6	63	2000	6	1140
G41R 315 MX6	110.0	1042	115	128.0	1008	95.3	0.86	185	8.2	3.2	65	2000	6.67	1210
G41R 315 L6	132.0	1253	139	153.0	1006	95	0.86	222	10.5	3.8	77	2000	8.6	1550
G41R 355 M6	160.0	1511	168	190.0	1011	95.3	0.84	275	6.8	2.8	102	2000	8.2	1850
G42R 355 MX6	200.0	1900	209	241.0	1005	95.5	0.83	348	9.7	2.8	134	2000	12.1	2340
G42R 355 LY6	250.0			305.0								2000	14	2400
G42R 355 L6	315.0			380.0								2000	14	2400

Energy-optimised three-phase asynchronous generators

Active components, design for optimised efficiency based on Premium Efficiency IE3

Surface cooling, type of cooling IC 411, duty type S1, continuous duty, thermal class 155 (F), degree of protection IP 55

Motor selection data														
Type	P _B	M _B	P _{auf}	S	n	η	cosφ _B	I _B	I _K /I _B	M _K /M _B	Q _n	n _{max}	J	m
IEC/DIN	kW	Nm	kW	kVA	rpm	%	-	A	-	-	kVAr	-	kgm ²	kg
Synchronous speed 750 rpm – 8-pole version														
G41R 132 M8	3.0	36.5	3.6	4.5	785	82.2	0.66	6.6	3.5	2.48	3.4	1800	0.043	74
G41R 160 M8	4.0	49.6	4.6	6.0	770	87.3	0.67	8.6	5.1	3.6	4.5	1800	0.113	114
G41R 160 MX8	5.5			8.5								1500	0.145	143
G41R 160 L8	7.5			10.0								1500	0.166	155
G41R 180 L8	11.0	136	12.2	15.3	770	89.8	0.72	22	4.8	3.1	10.6	1500	0.228	175
G41R 200 L8	15.0	186	16.6	19.5	772	90.2	0.77	28	4.9	3.1	12.5	1500	0.324	235
G41R 225 S8	18.5	230	20.5	24.0	768	90.4	0.77	34.5	5.8	2.6	15.3	1500	0.514	310
G41R 225 M8	22.0	275	24.0	29.7	764	91.8	0.74	43.0	6.1	3.1	20.0	1500	0.825	360
G41R 250 M8	30.0	374	32.6	39.5	767	92	0.76	57.0	5.6	2.8	25.7	1500	0.939	405
G41R 280 S8	37.0	465	40.0	48.0	760	92.8	0.77	69.5	5.9	3	30.6	1500	1.55	555
G41R 280 M8	45.0	565	48	56.0	760	93.5	0.8	81	8.8	3	33	1500	2.63	700
G42R 315 S8	55.0	695	59	72.0	756	94	0.76	104	7.3	3.3	46	1500	3.33	805
G41R 315 M8	75.0	945	79	96.0	758	94.9	0.78	139	7.3	2.9	60	1500	5.55	1120
G41R 315 MX8	90.0	1140	95	122.0	754	94.5	0.74	176	8.7	3.8	82	1500	6	1100
G41R 315 MY8	110.0	1382	116	138.0	760	94.6	0.8	198	6.8	2.7	83	1500	6.76	1250
G41R 315 L8	132.0	1665	139	171.0	757	94.7	0.77	247	8	3.2	109	1500	8.71	1180
G41R 355 M8	200.0	2533	210	263.0	754	95.4	0.76	380	7	3.3	171	1500	9.5	1850
G42R 355 MX8	250.0			300.0								1500	13.4	2200
G42R 355 L8	280.0			370.0								1500	15.8	2400

Energy-optimised three-phase asynchronous generators
Active components, design for optimised efficiency based on High Efficiency IE2

Surface cooling, type of cooling IC 411, duty type S1, continuous duty,
 thermal class 155 (F), degree of protection IP 55

Motor selection data														
Type	P _B	M _B	P _{auf}	S	n	η	cosφ _B	I _B	I _A /I _B	M _K /M _B	Q _n	η _{max}	J	m
IEC/DIN	kW	Nm	kW	kVA	rpm	%	-	A	-	-	kVAr	-	kgm ²	kg
Synchronous speed 1500 rpm – 4-pole version														
GE1R 112 M4	4.0	25	4.55	5.1	1531	87.9	0.78	7.4	8.3	8.7	3.2	3.600	0.017	56
GE1R 132 S4	5.5	35	6.1	6.2	1535	90.1	0.85	8.9	6.5	6.5	2.9	3.600	0.035	89
GE1R 132 M4	7.5	46.5	8.3	9.7	1530	90.3	0.78	14	7.7	6.5	6.2	3.600	0.035	88
GE1R 160 M4	11.0	68.8	12.18	13.4	1527	90.3	0.82	19.5	7.5	4.6	7.7	3.000	0.078	122
GE1R 160 L4	15.0	94	16.4	18.0	1524	91.2	0.84	26.0	8.6	5.2	9.9	3.000	0.115	160
GE1R 180 M4	18.5	116.2	19.9	22.2	1520	93.0	0.84	32.0	7.5	4.0	12.2	3.000	0.168	207
GE1R 180 L4	22.0	137.8	23.6	26.0	1525	93.1	0.85	37.5	5.8	3.7	13.9	3.000	0.168	215
GE1R 200 L4	30.0	188.1	32.1	35.2	1523	93.6	0.85	51.0	6.2	3.1	18.4	3.000	0.275	277
GE1R 225 S4	37.0	231.7	39.7	43.6	1525	93.2	0.85	63.0	6.2	3.1	23.2	3.000	0.313	313
GE1R 225 M4	45	281	48.3	57.5	1530	93.1	0.84	83	7.9	2.4	35.8	3.000	0.525	390
GE1R 250 M4	55	345	58.5	70.0	1522	94.0	0.84	101	8.0	2.3	43.3	3.000	0.95	535
GE1R 280 S4	75	472	79.6	94.9	1519	94.2	0.84	137	7.2	2.1	58.2	3.000	0.95	550
GE1R 280 M4	90	565	95.4	114	1520	94.3	0.84	164	7.6	2.3	70.0	3.000	1.10	610
GE1R 315 S4	110	695	116	141	1512	94.8	0.82	204	8.5	2.7	88.2	3.000	1.96	760
GE1R 315 M4	132	830	139	168	1519	95.0	0.83	242	8.2	2.3	104	3.000	2.27	850
GE1R 315 MX4	160	1007	168	200	1517	95.0	0.84	289	7.4	2.2	120	3.000	2.73	975
GE1R 315 MY4	200	1259	210	242	1517	95.1	0.87	349	8.5	2.5	136	3.000	4.82	1270
GE1R 315 L4	250	1579	262	298	1512	95.4	0.88	430	9.0	2.7	162	3.000	5.93	1450
GE1R 315 LX4	315	1991	330	376	1511	95.4	0.88	542	9.0	2.6	205	3.000	6.82	1630
GE2R 355 M4	355	2248	372	427	1508	95.5	0.87	617	8.0	2.7	237	3.000	7.90	2150
GE2R 355 MX4	400	2531	419	476	1509	95.5	0.88	687	8.5	3.0	258	3.000	9.50	2400
GE2R 355 LY4	450	2852	471	548	1507	95.5	0.86	791	8.5	2.9	313	3.000	10.00	2500
GE2R 355 L4	500	3164	524	624	1509	95.5	0.84	900	8.0	3.0	373	3.000	10.00	2500
Synchronous speed 1000 rpm – 6-pole version														
GE1R 132 S6	3.0	27.7	3.58	4.2	1035	83.8	0.72	6	4.6	5.1	2.9	2.400	0.023	55
GE1R 132 M6	4.0	37.1	4.6	5.5	1030	87.1	0.72	8	4.6	3.5	3.8	2.400	0.043	74
GE1R 132 MX6	5.5	51.1	6.4	7.3	1028	85.9	0.76	10.5	5.2	3.8	4.7	2.400	0.053	87
GE1R 160 M6	7.5	70	8.56	10.0	1023	87.6	0.75	14.5	5.82	4.0	6.7	2.400	0.113	118
GE1R 160 L6	11.0	102.5	12.4	14.0	1025	89.0	0.78	20.5	5.7	3.6	8.7	2.000	0.145	137
GE1R 180 L6	15.0	139.8	16.7	17.0	1025	89.7	0.88	24.5	5.8	3.4	8.0	2.000	0.228	185
GE1R 200 L6	18.5	172.5	20.4	21.5	1024	90.7	0.86	31.0	6	3.4	11.0	2.000	0.268	208
GE1R 200 LX6	22.0	205.4	24	24.9	1023	91.6	0.88	36.0	6.1	3.3	11.7	2.000	0.443	272
GE1R 225 M6	30.0	282.3	32.4	35.7	1015	92.5	0.84	51.5	7.17	3.6	19.3	2.000	0.825	365
GE1R 250 M6	37	346	40.1	47.1	1021	92.2	0.85	68	6.4	2.4	29.2	2.000	1.28	480
GE1R 280 S6	45	421	48.4	55.8	1020	93.0	0.87	80.5	6.5	2.4	32.9	2.000	1.48	560
GE1R 280 M6	55	516	58.8	69.3	1018	93.5	0.85	100	7.6	2.5	42.2	2.000	2.63	710
GE1R 315 S6	75	706	79.9	92.1	1014	93.9	0.87	133	7.8	2.5	53.5	2.000	3.33	804
GE1R 315 M6	90	851	95.7	109	1010	94.0	0.88	157	7.5	2.5	61.5	2.000	3.60	865
GE1R 315 MX6	110	1036	117	134	1014	94.3	0.87	194	7.5	2.3	76.5	2.000	6.67	1210
GE1R 315 MY6	132	1248	140	160	1010	94.6	0.87	231	7.5	2.2	90.4	2.000	6.67	1250
GE1R 315 L6	160	1510	169	192	1012	94.8	0.88	277	7.5	2.4	106	2.000	8.60	1430
GE1R 315 LX6	200	1885	211	245	1013	95.0	0.86	353	7.0	2.2	142	2.000	8.60	1460
GE2R 355 M6	250	2371	263	313	1007	95.0	0.84	452	7.0	2.2	188	2.000	8.20	1850
GE2R 355 MX6	315	2973	331	385	1012	95.2	0.86	555	7.0	2.2	221	2.000	12.1	2200
GE2R 355 LY6	355	3367	374	485	1007	95.0	0.77	700	7.5	2.6	330	2.000	14.0	2400

Energy-optimised three-phase asynchronous generators

Active components, design for optimised efficiency based on High Efficiency IE2

Surface cooling, type of cooling IC 411, duty type S1, continuous duty,
thermal class 155 (F), degree of protection IP 55

Motor selection data														
Type	P_B	M_B	P_{auf}	S	n	η	$\cos\phi_B$	I_B	I_A/I_B	M_K/M_B	Q_n	η_{max}	J	m
IEC/DIN	kW	Nm	kW	kVA	rpm	%	-	A	-	-	kVAr	-	kgm ²	kg
Synchronous speed 750 rpm – 8-pole version														
GE1R 132 S8	2.20	26.6	2.86	3.74	790	76.8	0.59	5.40	3.40	3.60	3.00	1.800	0.023	53
GE1R 132 M8	3.00	36.6	3.73	4.85	783	80.5	0.62	7.00	3.60	2.80	3.80	1.800	0.043	70
GE1R 160 M8	4.00	48.9	4.91	6.58	781	81.5	0.61	9.50	4.50	3.30	4.50	1.800	0.053	86
GE1R 160 MX8	5.50	67.7	6.47	8.66	776	85.0	0.63	12.50	4.20	2.90	6.70	1.800	0.113	114
GE1R 160 L8	7.5	92.9	8.67	11.1	771	86.5	0.68	16.0	4.5	3.2	8.2	1.500	0.145	136
GE1R 180 L8	11.0	136.3	12.3	13.6	771	89.6	0.81	19.5	4.9	2.9	8.0	1.500	0.228	175
GE1R 200 L8	15.0	185.8	16.8	18.7	771	89.5	0.80	27.0	4.9	3.0	11.2	1.500	0.228	200
GE1R 225 S8	18.5	230	23.1	23.1	768	90.8	0.80	33.5	5.4	3.2	14.5	1.500	0.440	265
GE1R 225 M8	22	273	24.3	31.2	770	90.6	0.78	45	5.6	2.6	22.1	1.500	0.825	380
GE1R 250 M8	30	374	32.6	41.2	767	92.1	0.79	59.5	5.0	2.1	28.3	1.500	1.350	480
GE1R 280 S8	37	462	40.1	50.9	765	92.2	0.79	73.5	6.0	2.5	35.0	1.500	1.55	550
GE1R 280 M8	45	563	48.5	61.3	763	92.7	0.79	88.5	6.7	2.5	41.6	1.500	2.63	690
GE1R 315 S8	55	696	59.7	74.8	755	92.2	0.80	108	6.3	2.3	50.7	1.500	2.63	690
GE1R 315 M8	75	942	80.2	99.1	760	93.5	0.81	143	6.0	2.1	64.8	1.500	3.6	880
GE1R 315 MX8	90	1131	97.7	121	760	92.1	0.81	174	6.0	2.2	80.9	1.500	6	1050
GE1R 315 MY8	110	1382	117	145	760	93.8	0.81	209	6.5	2.4	94.5	1.500	6.76	1250
GE1R 315 L8	132	1659	140	168	760	94.4	0.83	243	7.5	2.5	104	1.500	8.71	1430
GE1R 315 LX8	160	2011	170	212	760	94.2	0.80	306	7.2	2.5	139	1.500	8.71	1430
GE2R 355 M8	200	2530	211	274	755	94.7	0.77	396	a.A.	a.A.	187	1.500	9.5	1850
GE2R 355 MX8	250	3158	261	315	756	95.8	0.83	454	7.0	2.6	192	1.500	13.4	2200
GE2R 355 LY8	280	3532	295	379	757	94.8	0.78	547	a.A.	a.A.	255	1.500	15.8	2400

Three-phase asynchronous generators

Surface cooling, type of cooling IC 411, duty type S1, continuous duty, thermal class 155 (F), degree of protection IP 55

Motor selection data		P_B	P_{auf}	S	n	η	$\cos\phi_B$	I_B	I_A/I_B	M_A/M_B	Q_n	n_{max}	J	m
Typ	progressive	kW	kW	kVA	rpm	%	-	A	-	-	kVAr	-	kgm ²	kg
IEC/DIN														
Synchronous speed 3000 rpm – 2-pole version														
G21R 132 S2	G20R 112 MY2	5.5	6.58	7.3	3115	83.55	0.76	10.5	5.6	6.2	4.8	7.000	0.0081	52
G21R 132 SX2	G20R 112 M2	7.5	8.6	9.7	3087	87.21	0.77	14.0	7.3	6.9	6.2	7.000	0.011	57
G21R 160 M2	G20R 132 M2	11.0	12.63	12.5	3087	87.11	0.88	18.1	6.5	5.23	6.0	6.000	0.0258	81
G21R 160 MX2	G20R 160 S2	15.0	16.85	16.9	3081	89.03	0.89	24.3	5.5	3.52	7.7	6.000	0.0575	118
G21R 160 L2	G20R 160 M2	18.5	20.56	19.8	3059	90	0.93	28.6	7.4	4.33	7.2	6.000	0.0675	134
G21R 180 M2	G20R 180 S2	22.0	24.05	24.9	3055	91.47	0.88	36.0	7.2	4.7	11.8	6.000	0.105	165
G21R 200 L2	G20R 180 M2	30.0	32.57	34.1	3065	92.1	0.88	49.0	7.2	3.1	16.2	5.000	0.128	195
G21R 200 LX2	G20R 200 M2	37.0	39.74	42.3	3046	93.1	0.87	61.1	6.2	3.7	20.5	5.000	0.193	255
G21R 225 M2	G20R 200 L2	45.0	48	49.9	3050	93.75	0.90	72.0	7.7	4.4	21.5	5.000	0.22	290
Synchronous speed 1500 rpm – 4-pole version														
G21R 132 S4	G20R 112 M4	5.5	6.45	6.62	1548	85.23	0.83	9.6	6.0	7	3.7	3.600	0.01500	50
G21R 132 M4	G20R 132 S4	7.5	8.72	9.41	1553	86	0.80	13.6	4.6	3.3	5.7	3.600	0.0280	70
G21R 160 M4	G20R 132 M4	11.0	12.47	13.58	1544	88.25	0.81	19.6	5.8	4.7	8.0	3.600	0.0350	92
G21R 160 L4	G20R 160 S4	15.0	16.72	17.95	1535	89.7	0.84	25.9	5.8	3.7	9.9	3.600	0.0780	120
G21R 180 M4	G20R 160 M4	18.5	20.72	22.7	1532	89.3	0.81	32.8	6.6	4	13.2	3.000	0.0900	136
G21R 180 L4	G20R 180 S4	22	24.06	26.9	1536	91.46	0.82	38.8	5.1	2.9	15.5	3.000	0.1380	170
G21R 200 L4	G20R 180 M4	30	33	36.28	1537	91.63	0.83	52.4	5.1	2.7	20.4	3.000	0.1680	200
G21R 225 S4	G20R 200 M4	37	40	44.63	1530	92.83	0.83	64.4	5.4	2.7	25.0	3.000	0.2750	270
G21R 225 M4	G20R 200 L4	45	48	53.79	1530	93.25	0.84	77.6	5.5	2.7	29.5	3.000	0.3130	300
G21R 250 M4	G20R 225 M4	55	59	65.5	1522	93.5	0.84	94.5	7.0	3.1	35.6	3.000	0.5250	375
G21R 280 S4	G20R 250 S4	75	80	89.5	1519	94.1	0.84	129.0	7.0	2.9	48.8	3.000	0.9500	520
G21R 280 M4	G20R 250 M4	90	95	106	1520	94.6	0.85	153.0	7.0	2.9	56.0	3.000	1.10	580
G21R 315 S4	G20R 280 S4	110	117	134	1512	94.4	0.82	194.0	10.5	3.8	77.0	3.000	1.96	740
G21R 315 M4	G20R 280 M4	132	140	155	1519	94.5	0.85	224.0	6.6	2.2	81.0	3.000	2.27	840
G21R 315 MX4	G20R 315 S4	160	168	188	1517	95	0.85	272.0	7.5	2.5	99.0	3.000	2.73	1000
G21R 315 MY4	G20R 315 M4	200	211	233	1517	95	0.86	336.0	6.7	2.4	120.0	3.000	4.82	1200
G21R 315 L 4	G20R 315 L4	250	262	287	1512	95.5	0.87	415.0	8.0	2.7	141.0	3.000	5.93	1450
G21R 315 LX4	G20R 315 LX4	315	329	366	1511	95.8	0.86	529.0	8.3	3	186.0	3.000	6.82	1630
G22R 355 MY4		315	330	389	1508	95.5	0.81	561.0	7.0	3.5	228	3.000	5.60	1950
G22R 355 M4		355	372	413	1509	95.5	0.86	596.0	6.8	3.1	211	3.000	7.9	2150
G22R 355 MX4		400	419	465	1507	95.5	0.86	671.0	8.6	3.9	273	3.000	9.5	2400
G22R 355 LY4		420	437	505	1509	96.2	0.83	730.0	8.5	3.5	282	3.000	10.0	2500
Synchronous speed 1000 rpm – 6-pole version														
G21R 132 S6	G20R 112 M6	3.0	3.74	4.54	1040	80.24	0.66	6.6	5.0	5.5	3.4	2.400	0.0180	46
G21R 132 M6	G20R 112 MX 6	4.0	4.89	5.9	1037	81.88	0.68	8.5	5.2	5.5	4.3	2.400	0.0230	53
G21R 132 MX6	G20R 132 S6	5.5	6.62	7.89	1033	83.03	0.70	11.4	4.5	3.7	5.7	2.400	0.0430	70
G21R 160 M6	G20R 132 M6	7.5	8.81	9.94	1036	85.15	0.75	14.4	4.6	3.6	6.5	2.400	0.0530	86
G21R 160 L6	G20R 160 S6	11.0	12.74	13.49	1035	86.34	0.82	19.5	4.6	2.8	7.8	2.400	0.1130	114
G21R 180 L6	G20R 160 M6	15.0	17.08	18.29	1032	87.8	0.82	26.4	4.9	3.2	10.5	2.000	0.1450	136
G21R 200 L6	G20R 180 S6	18.5	20.77	21.37	1029	89.07	0.87	30.8	5.2	3.2	10.7	2.000	0.2280	175
G21R 200 LX6	G20R 180 M6	22	24.6	27.14	1027	89.42	0.81	39.2	5.4	3.4	15.9	2.000	0.2680	200
G21R 225 M6	G20R 200 M6	30	33.12	34.93	1029	90.57	0.86	50.4	5.4	3.1	17.9	2.000	0.4430	284
G21R 250 M6	G20R 225 M6	37	40	43.4	1021	91.8	0.85	63.0	6.0	3.7	22.7	2.000	0.8250	375
G21R 280 S6	G20R 250 S6	45	49	55	1020	92	0.83	78.5	6.0		31.6	2.000	1.28	465
G21R 280 M6	G20R 250 M6	60	65	69.1	1018	91.2	0.86	101.0	6.0	2.5	34.3	2.000	1.48	575
G21R 315 S6	G20R 280 S6	75	80	87	1014	93.5	0.86	126.0	6.5	2.9	44.0	2.000	2.63	690
G21R 315 M6	G20R 280 M6	90	96	107	1010	93.8	0.84	155.0	7.2	3.1	58.0	2.000	3.33	800
G21R 315 MX6	G20R 315 S6	110	116	126	1014	94.5	0.87	182.0	6.5	2.7	61.0	2.000	3.60	880
G21R 315 MY6	G20R 315 M6	132	140	157	1010	94.5	0.84	227.0	6.6	2.6	85.0	2.000	6.00	1050
G21R 315 L6	G20R 315 L6	160	169	188	1012	94.5	0.85	272.0	6.5	2.5	99.0	2.000	6.67	1250
G21R 315 LX6	G20R 315 LX6	200	211	235	1013	95	0.85	340.0	7.7	2.6	124.0	2.000	8.6	1460
G22R 355 MY6		200	209	235	1007	95.5	0.85	340.0	6.9	2.5	124	2.000	8.1	1550
G22R 355 M6		250	264	305	1012	94.8	0.82	440.0	7.0	2.8	175	2.000	8.2	1650
G22R 355 MX6		315	329	375	1007	95.7	0.84	541.0	7.9	3	203	2.000	12.1	2200
G22R 355 LY6		355	371	418	1007	95.8	0.85	603.0	8.0	3	220	2.000	14.0	2400

Three-phase asynchronous generators

Surface cooling, type of cooling IC 411, duty type S1, continuous duty,
thermal class 155 (F), degree of protection IP 55

Motor selection data														
Typ		P_B	P_{auf}	S	n	η	$\cos\phi_B$	I_B	I_A/I_B	M_A/M_B	Q_n	n_{max}	J	m
IEC/DIN	progressive	kW	kW	kVA	rpm	%	-	A	-	-	kVAr	-	kgm ²	kg
Synchronous speed 750 rpm – 8-pole version														
G21R 132 S8	G20R 112 M8	2.2	3.1	4.3	793	70.3	0.51	6.2	4.0	6.3	3.0	1.800	0.01800	46
G21R 132 M8	G20R 112 MX8	3.0	3.6	5.5	793	84	0.54	8.0	4.0		4.6	1.800	0.0230	53
G21R 160 M8	G20R 132 S8	4.0	5.1	6.7	787	77.9	0.59	9.8	4.0	3.5	5.4	1.800	0.0430	70
G21R 160 MX8	G20R 132 M8	5.5	6.9	8.9	790	80	0.62	13.0	4.0		7.0	1.800	0.0530	86
G21R 160 L8	G20R 160 S8	7.5	9.3	12.4	777	80.3	0.60	18.0	4.5	3.9	9.9	1.800	0.1130	114
G21R 180 L8	G20R 160 M8	11.0	13.3	17.6	781	82.7	0.62	25.5	4.5	3.7	13.7	1.500	0.1450	136
G21R 200 L8	G20R 180 S8	15.0	17.4	22.3	774	86.1	0.67	32.5	5.0	3.6	16.5	1.500	0.228	175
	G20R 180 M8	18.5	21	26.3	780	88	0.70	38.0	5.0		18.7	1.500	0.268	200
G21R 225 S8		18.5	21	26.3	780	88	0.70	38.0	5.0		18.7	1.500	0.440	265
G21R 225 M8	G20R 200 M8	22	25	30.9	770	89	0.71	44.5	5.0		21.7	1.500	0.440	265
G21R 250 M8	G20R 225 M8	30	33.5	39.8	767	89.5	0.75	57.5	5.5	3.8	26.2	1.500	0.825	360
G21R 280 S8	G20R 250 S8	37	41	50	765	91	0.74	72.0	5.5		33.6	1.500	1.35	465
G21R 280 M8	G20R 250 M8	45	49	60	763	92	0.75	86.5	5.5	3.4	39.7	1.500	1.55	520
G21R 315 S8	G20R 280 S8	55	59	75	755	93	0.73	109.0	6.7	4.5	51.0	1.500	2.63	690
G21R 315 M8	G20R 280 M8	75	80	97	760	93.5	0.77	141.0	6.4	2.8	62.0	1.500	3.33	800
G21R 315 MX8	G20R 315 S8	90	96	120	760	93.5	0.75	173.0	6.0	2.6	79.0	1.500	3.60	880
G21R 315 MY8	G20R 315 M8	110	118	143	760	93.5	0.77	206.0	6.2	2.5	91.0	1.500	6.00	1050
G21R 315 L8	G20R 315 L8	132	141	165	760	93.5	0.80	238.0	6.5	2.7	99.0	1.500	6.76	1250
G21R 315 LX8	G20R 315 LX8	160	170	200	760	94	0.80	289.0	7.0	2.7	120.0	1.500	8.71	1430
G22R 355 MY8		160	168	213	755	95.2	0.75	308.0	7.0	3	141	1.500	9.3	1500
G22R 355 M8		200	211	256	756	94.8	0.78	370.0	6.0	2.9	160	1.500	9.5	1600
G22R 355 MX8		250	262	298	757	95.3	0.84	361.0	5.7	2.6	162	1.500	13.4	2200
G22R 355 LY8		280	295	394	756	95	0.71	569.0	7.2	3	278	1.500	15.8	2400

Terminal boxes, bearings and dimensions

The asynchronous generators G4.R are identical to the series IE3-W4.R.

For further information regarding the terminal boxes, bearings and dimensions, please refer to Chapter 2.

Assignment table			
Type	Type	J	m
G41R	IE3-W4.R	kgm ²	kg
Synchronous speed 1500 rpm – 4-pole version			
G41R 112 M4	IE3-W41R 112 M4	0.02	65
G41R 132 S4	IE3-W41R 132 S4	0.035	90
G41R 132 M4	IE3-W41R 132 M4	0.043	100
G41R 160 M4	IE3-W41R 160 M4	0.078	125
G41R 160 L4	IE3-W41R 160 L4	0.1567	175
G41R 180 M4	IE3-W41R 180 M4	0.168	210
G41R 180 L4	IE3-W41R 180 L4	0.203	240
G41R 200 L4	IE3-W41R 200 L4	0.411	327
G41R 225 S4	IE3-W41R 225 S4	0.4675	367
G41R 225 M4	IE3-W41R 225 M4	0.619	450
G41R 250 M4	IE3-W41R 250 M4	0.95	550
G41R 280 S4	IE3-W41R 280 S4	1.1	617
G41R 280 M4	IE3-W41R 280 M4	1.96	785
G41R 315 S4	IE3-W41R 315 S4	1.96	760
G41R 315 M4	IE3-W41R 315 M4	2.27	850
G42R 315 MX4	IE3-W42R 315 MX4	4.02	1070
G41R 315 MY4	IE3-W41R 315 MY4	4.82	1250
G41R 315 L4	IE3-W41R 315 L4	5.93	1450
G41R 315 LX4	IE3-W41R 315 LX4	6.82	1630
G41R 355 M4	IE3-W41R 355 M4	7.90	2150
G42R 355 MX4	IE3-W42R 355 MX4	9.5	2400
G42R 355 L4	IE3-W42R 355 L4	10	2500

Synchronous speed 750 rpm – 8-pole version			
G41R 132 M8	IE3-W41R 132 M8	0.043	74
G41R 160 M8	IE3-W41R 160 M8	0.113	114
G41R 160 MX8	IE3-W41R 160 MX8	0.145	143
G41R 160 L8	IE3-W41R 160 L8	0.166	155
G41R 180 L8	IE3-W41R 180 L8	0.228	175
G41R 200 L8	IE3-W41R 200 L8	0.324	235
G41R 225 S8	IE3-W41R 225 S8	0.514	310
G41R 225 M8	IE3-W41R 225 M8	0.825	360
G41R 250 M8	IE3-W41R 250 M8	0.92	400
G41R 280 S8	IE3-W41R 280 S8	1.55	520
G41R 280 M8	IE3-W41R 280 M8	2.63	700
G42R 315 S8	IE3-W42R 315 S8	3.33	800
G41R 315 M8	IE3-W41R 315 M8	5.55	1060
G41R 315 MX8	IE3-W41R 315 MX8	6	1100
G41R 315 L8	IE3-W41R 315 L8	6.76	1180
G41R 355 M8	IE3-W41R 355 M8	8.71	1450
G42R 355 MX8	IE3-W42R 355 MX8	13.4	2200
G42R 355 L8	IE3-W42R 355 L8	15.8	2400

Type	Type	J	m
G41R	IE3-W4.R	kgm ²	kg
Synchronous speed 1000 rpm – 6-pole version			
G41R 132 S6	IE3-W41R 132 S6	0.029	70
G41R 132 M6	IE3-W41R 132 M6	0.043	75
G41R 132 MX6	IE3-W41R 132 MX6	0.053	105
G41R 160 M6	IE3-W41R 160 M6	0.145	145
G41R 160 L6	IE3-W41R 160 L6	0.166	168
G41R 180 L6	IE3-W41R 180 L6	0.3396	214
G41R 200 L6	IE3-W41R 200 L6	0.514	310
G41R 200 LX6	IE3-W41R 200 LX6	0.6476	321
G41R 225 M6	IE3-W41R 225 M6	0.92	400
G41R 250 M6	IE3-W41R 250 M6	1.48	545
G41R 280 S6	IE3-W41R 280 S6	2.63	695
G41R 280 M6	IE3-W41R 280 M6	3.33	815
G42R 315 S6	IE3-W42R 315 S6	5.55	1060
G41R 315 M6	IE3-W41R 315 M6	6	1100
G41R 315 MX6	IE3-W41R 315 MX6	6.67	1210
G41R 315 L6	IE3-W41R 315 L6	8.6	1550
G41R 355 M6	IE3-W41R 355 M6	8.2	1850
G42R 355 MX6	IE3-W42R 355 MX6	12.1	2200
G42R 355 LY6	IE3-W42R 355 LY6	14	2400
G42R 355 L6	IE3-W42R 355 L6	14	2400

The asynchronous generators GE.R are identical to the series IE2-WE.R.
For further information regarding the terminal boxes, bearings and dimensions, please refer to Chapter 2.

Assignment table			
Type	Type	J	m
GE.R	IE2-WE.R	kgm ²	kg
Synchronous speed 1500 rpm – 4-pole version			
GE1R 112 M4	IE2-WE1R 112M 4	0.017	56
GE1R 132 S4	IE2-WE1R 132S 4	0.035	87
GE1R 132 M4	IE2-WE1R 132M 4	0.035	88
GE1R 160 M4	IE2-WE1R 160M 4	0.078	122
GE1R 160 L4	IE2-WE1R 160L 4	0.115	160
GE1R 180 M4	IE2-WE1R 180M 4	0.168	207
GE1R 180 L4	IE2-WE1R 180L 4	0.168	215
GE1R 200 L4	IE2-WE1R 200L 4	0.275	277
GE1R 225 S4	IE2-WE1R 225S 4	0.313	313
GE1R 225 M4	IE2-WE1R 225 M4	0.525	390
GE1R 250 M4	IE2-WE1R 250 M4	0.95	535
GE1R 280 S4	IE2-WE1R 280 S4	0.95	550
GE1R 280 M4	IE2-WE1R 280 M4	1.10	610
GE1R 315 S4	IE2-WE1R 315 S4	1.96	760
GE1R 315 M4	IE2-WE1R 315 M4	2.27	850
GE1R 315 MX4	IE2-WE1R 315 MX4	2.73	975
GE1R 315 MY4	IE2-WE1R 315 MY4	4.82	1270
GE1R 315 L4	IE2-WE1R 315 L4	5.93	1450
GE1R 315 LX4	IE2-WE1R 315 LX4	6.82	1630
GE2R 355 M4	IE2-WE2R 355 M4	7.90	2150
GE2R 355 MX4	IE2-WE2R 355 MX4	9.50	2400
GE2R 355 LY4	IE2-WE2R 355 LY4	10.00	2500
GE2R 355 L4	IE2-WE2R 355 L4	10.00	2500

Synchronous speed 750 rpm – 8-pole version			
GE1R 132 S8	IE2-WE1R 132S 8	0.023	53
GE1R 132 M8	IE2-WE1R 132M 8	0.043	70
GE1R 160 M8	IE2-WE1R 160M 8	0.053	86
GE1R 160 MX8	IE2-WE1R 160MX 8	0.113	114
GE1R 160 L8	IE2-WE1R 160L 8	0.145	136
GE1R 180 L8	IE2-WE1R 180L 8	0.228	175
GE1R 200 L8	IE2-WE1R 200L 8	0.228	200
GE1R 225 S8	IE2-WE1R 225S 8	0.440	265
GE1R 225 M8	IE2-WE1R 225 M8	0.825	380
GE1R 250 M8	IE2-WE1R 250 M8	1.350	480
GE1R 280 S8	IE2-WE1R 280 S8	1.55	550
GE1R 280 M8	IE2-WE1R 280 M8	2.63	690
GE1R 315 S8	IE2-WE1R 315 S8	2.63	690
GE1R 315 M8	IE2-WE1R 315 M8	3.6	880
GE1R 315 MX8	IE2-WE1R 315 MX8	6	1050
GE1R 315 MY8	IE2-WE1R 315 MY8	6.76	1250
GE1R 315 L8	IE2-WE1R 315 L8	8.71	1430
GE1R 315 LX8	IE2-WE1R 315 LX8	8.71	1430
GE2R 355 M8	IE2-WE2R 355 M8	9.5	1850
GE2R 355 MX8	IE2-WE2R 355 MX8	13.4	2200
GE2R 355 LY8	IE2-WE2R 355 LY8	15.8	2400

Type	Type	J	m
GE.R	IE2-WE.R	kgm ²	kg
Synchronous speed 1000 rpm – 6-pole version			
GE1R 132 S6	IE2-WE1R 132S 6	0.023	55
GE1R 132 M6	IE2-WE1R 132M 6	0.043	74
GE1R 132 MX6	IE2-WE1R 132MX 6	0.053	87
GE1R 160 M6	IE2-WE1R 160M 6	0.113	118
GE1R 160 L6	IE2-WE1R 160L 6	0.145	137
GE1R 180 L6	IE2-WE1R 180L 6	0.228	185
GE1R 200 L6	IE2-WE1R 200L 6	0.268	208
GE1R 200 LX6	IE2-WE1R 200LX 6	0.443	272
GE1R 225 M6	IE2-WE1R 225M 6	0.825	365
GE1R 250 M6	IE2-WE1R 250 M6	1.28	480
GE1R 280 S6	IE2-WE1R 280 S6	1.48	560
GE1R 280 M6	IE2-WE1R 280 M6	2.63	710
GE1R 315 S6	IE2-WE1R 315 S6	3.33	804
GE1R 315 M6	IE2-WE1R 315 M6	3.60	865
GE1R 315 MX6	IE2-WE1R 315 MX6	6.67	1210
GE1R 315 MY6	IE2-WE1R 315 MY6	6.67	1250
GE1R 315 L6	IE2-WE1R 315 L6	8.60	1430
GE1R 315 LX6	IE2-WE1R 315 LX6	8.60	1460
GE2R 355 M6	IE2-WE2R 355 M6	8.20	1850
GE2R 355 MX6	IE2-WE2R 355 MX6	12.1	2200
GE2R 355 LY6	IE2-WE2R 355 LY6	14.0	2400

The asynchronous generators G21R are identical to the series K21R.

For further information regarding the terminal boxes, bearings and dimensions, please refer to Chapter 2.

Assignment table

Type	Type	J	m		
IEC/DIN	Progressive assignment				
G21R/G22R	K21R/K22R	G20R	K20R		
Synchronous speed 3000 rpm – 2-pole version					
		kgm ²	kg		
G21R 132 S2	K21R 132 S2	G20R 112 MY2	K20R 112 MY2	0.0081	52
G21R 132 SX2	K21R 132 SX2	G20R 112 M2	K20R 112 M2	0.011	57
G21R 160 M2	K21R 160 M2	G20R 132 M2	K20R 132 M2	0.0258	81
G21R 160 MX2	K21R 160 MX2	G20R 160 S2	K20R 160 S2	0.0575	118
G21R 160 L2	K21R 160 L2	G20R 160 M2	K20R 160 M2	0.0675	134
G21R 180 M2	K21R 180 M2	G20R 180 S2	K20R 180 S2	0.105	165
G21R 200 L2	K21R 200 L2	G20R 180 M2	K20R 180 M2	0.128	195
G21R 200 LX2	K21R 200 LX2	G20R 200 M2	K20R 200 M2	0.193	255
G21R 225 M2	K21R 225 M2	G20R 200 L2	K20R 200 L2	0.22	290
Synchronous speed 1500 rpm – 4-pole version					
G21R 132 S4	K21R 132 S4	G20R 112 M4	K20R 112 M4	0.01500	50
G21R 132 M4	K21R 132 M4	G20R 132 S4	K20R 132 S4	0.0280	70
G21R 160 M4	K21R 160 M4	G20R 132 M4	K20R 132 M4	0.0350	92
G21R 160 L4	K21R 160 L4	G20R 160 S4	K20R 160 S4	0.0780	120
G21R 180 M4	K21R 180 M4	G20R 160 M4	K20R 160 M4	0.0900	136
G21R 180 L4	K21R 180 L4	G20R 180 S4	K20R 180 S4	0.1380	170
G21R 200 L4	K21R 200 L4	G20R 180 M4	K20R 180 M4	0.1680	200
G21R 225 S4	K21R 225 S4	G20R 200 M4	K20R 200 M4	0.2750	270
G21R 225 M4	K21R 225 M4	G20R 200 L4	K20R 200 L4	0.3130	300
G21R 250 M4	K21R 250 M4	G20R 225 M4	K20R 225 M4	0.5250	375
G21R 280 S4	K21R 280 S4	G20R 250 S4	K20R 250 S4	0.9500	520
G21R 280 M4	K21R 280 M4	G20R 250 M4	K20R 250 M4	1.10	580
G21R 315 S4	K21R 315 S4	G20R 280 S4	K20R 280 S4	1.96	740
G21R 315 M4	K21R 315 M4	G20R 280 M4	K20R 280 M4	2.27	840
G21R 315 MX4	K21R 315 MX4	G20R 315 S4	K20R 315 S4	2.73	1000
G21R 315 MY4	K21R 315 MY4	G20R 315 M4	K20R 315 M4	4.82	1200
G21R 315 L 4	K21R 315 L 4	G20R 315 L4	K20R 315 L4	5.93	1450
G21R 315 LX4	K21R 315 LX4	G20R 315 LX4	K20R 315 LX4	6.82	1630
G22R 355 MY4	K22R 355 MY4			5.60	1950
G22R 355 M4	K22R 355 M4			7.9	2150
G22R 355 MX4	K22R 355 MX4			9.5	2400
G22R 355 LY4	K22R 355 LY4			10.0	2500
Synchronous speed 1000 rpm – 6-pole version					
G21R 132 S6	K21R 132 S6	G20R 112 M6	K20R 112 M6	0.0180	46
G21R 132 M6	K21R 132 M6	G20R 112 MX 6	K20R 112 MX 6	0.0230	53
G21R 132 MX6	K21R 132 MX6	G20R 132 S6	K20R 132 S6	0.0430	70
G21R 160 M6	K21R 160 M6	G20R 132 M6	K20R 132 M6	0.0530	86
G21R 160 L6	K21R 160 L6	G20R 160 S6	K20R 160 S6	0.1130	114
G21R 180 L6	K21R 180 L6	G20R 160 M6	K20R 160 M6	0.1450	136
G21R 200 L6	K21R 200 L6	G20R 180 S6	K20R 180 S6	0.2280	175
G21R 200 LX6	K21R 200 LX6	G20R 180 M6	K20R 180 M6	0.2680	200
G21R 225 M6	K21R 225 M6	G20R 200 M6	K20R 200 M6	0.4430	284
G21R 250 M6	K21R 250 M6	G20R 225 M6	K20R 225 M6	0.8250	375
G21R 280 S6	K21R 280 S6	G20R 250 S6	K20R 250 S6	1.28	465
G21R 280 M6	K21R 280 M6	G20R 250 M6	K20R 250 M6	1.48	575
G21R 315 S6	K21R 315 S6	G20R 280 S6	K20R 280 S6	2.63	690
G21R 315 M6	K21R 315 M6	G20R 280 M6	K20R 280 M6	3.33	800
G21R 315 MX6	K21R 315 MX6	G20R 315 S6	K20R 315 S6	3.60	880
G21R 315 MY6	K21R 315 MY6	G20R 315 M6	K20R 315 M6	6.00	1050
G21R 315 L6	K21R 315 L6	G20R 315 L6	K20R 315 L6	6.67	1250
G21R 315 LX6	K21R 315 LX6	G20R 315 LX6	K20R 315 LX6	8.6	1460
G22R 355 MY6	K22R 355 MY6			8.1	1550
G22R 355 M6	K22R 355 M6			8.2	1650
G22R 355 MX6	K22R 355 MX6			12.1	2200
G22R 355LY6	K22R 355LY6			14.0	2400

The asynchronous generators G21R are identical to the series K21R.
For further information regarding the terminal boxes, bearings and dimensions, please refer to Chapter 2.

Assignment table					
Type		Type		J	m
IEC/DIN		Progressive assignment			
G21R/G22R	K21R/K22R	G20R	K20R	kgm ²	kg
Synchronous speed 750 rpm – 8-pole version					
G21R 132 S8	K21R 132 S8	G20R 112 M8	K20R 112 M8	0.01800	46
G21R 132 M8	K21R 132 M8	G20R 112 MX8	K20R 112 MX8	0.0230	53
G21R 160 M8	K21R 160 M8	G20R 132 S8	K20R 132 S8	0.0430	70
G21R 160 MX8	K21R 160 MX8	G20R 132 M8	K20R 132 M8	0.0530	86
G21R 160 L8	K21R 160 L8	G20R 160 S8	K20R 160 S8	0.1130	114
G21R 180 L8	K21R 180 L8	G20R 160 M8	K20R 160 M8	0.1450	136
G21R 200 L8	K21R 200 L8	G20R 180 S8	K20R 180 S8	0.228	175
		G20R 180 M8	K20R 180 M8	0.268	200
G21R 225 S8	K21R 225 S8			0.440	265
G21R 225 M8	K21R 225 M8	G20R 200 M8	K20R 200 M8	0.440	265
G21R 250 M8	K21R 250 M8	G20R 225 M8	K20R 225 M8	0.825	360
G21R 280 S8	K21R 280 S8	G20R 250 S8	K20R 250 S8	1.35	465
G21R 280 M8	K21R 280 M8	G20R 250 M8	K20R 250 M8	1.55	520
G21R 315 S8	K21R 315 S8	G20R 280 S8	K20R 280 S8	2.63	690
G21R 315 M8	K21R 315 M8	G20R 280 M8	K20R 280 M8	3.33	800
G21R 315 MX8	K21R 315 MX8	G20R 315 S8	K20R 315 S8	3.60	880
G21R 315 MY8	K21R 315 MY8	G20R 315 M8	K20R 315 M8	6.00	1050
G21R 315 L8	K21R 315 L8	G20R 315 L8	K20R 315 L8	6.76	1250
G21R 315 LX8	K21R 315 LX8	G20R 315 LX8	K20R 315 LX8	8.71	1430
G22R 355 MY8	K22R 355 MY8			9.3	1500
G22R 355 M8	K22R 355 M8			9.5	1600
G22R 355 MX8	K22R 355 MX8			13.4	2200
G22R 355 LY8	K22R 355 LY8			15.8	2400



Built-on components

Contents

Modular design concept _____	14/2
Overview of available components _____	14/3
Brake assignments _____	14/4
Fan assignments _____	14/28

Modular design concept

The design concepts of the different motor series provide for the optional incorporation of components such as encoders, tacho generators, speed monitors, brakes and forced ventilation units to solve the customer's individual control tasks.

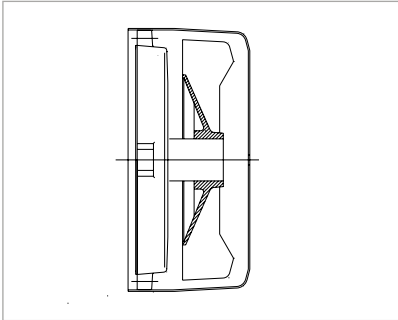

Standard version
Type of cooling IC 411, self-ventilated

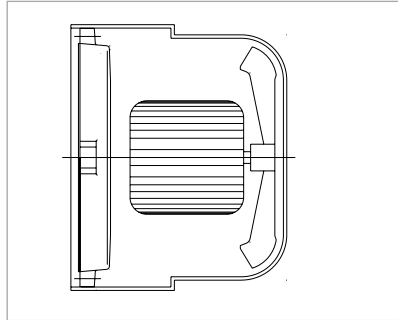

Special version
Type of cooling IC 416, forced ventilation

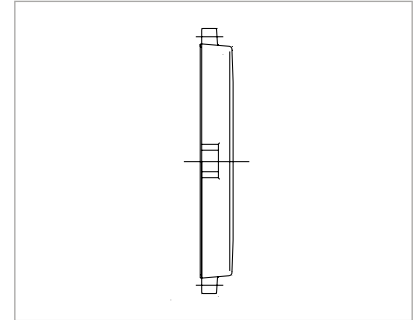

Special version
Type of cooling IC 410, non-ventilated

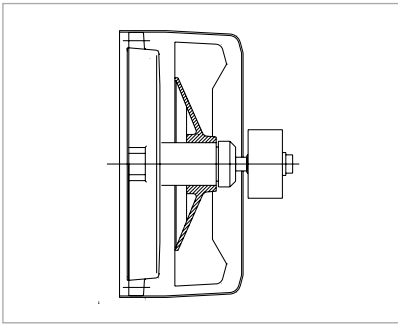

Special version
Type of cooling IC 411, self-ventilated with built-on incremental encoder

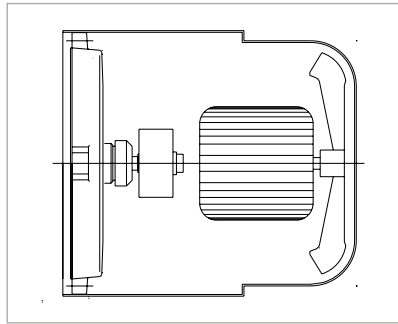

Special version
Type of cooling IC 416, forced ventilation with built-on incremental encoder

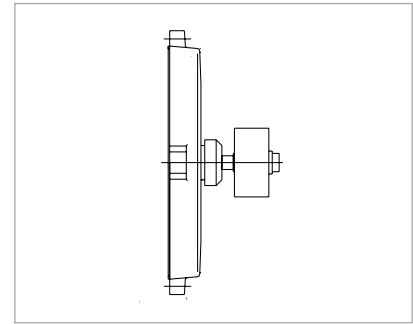

Special version
Type of cooling IC 410, non-ventilated with built-on incremental encoder

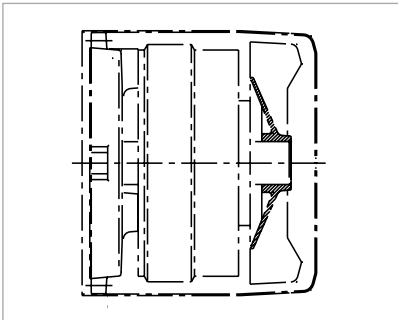

Special version
Type of cooling IC 411, self-ventilated with built-on brake

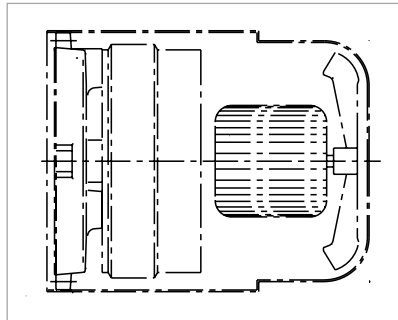

Special version
Type of cooling IC 416, forced ventilation with built-on brake

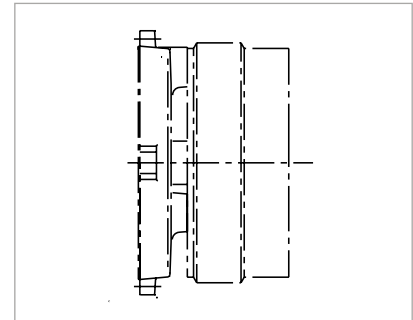

Special version
Type of cooling IC 410, non-ventilated with built-on brake

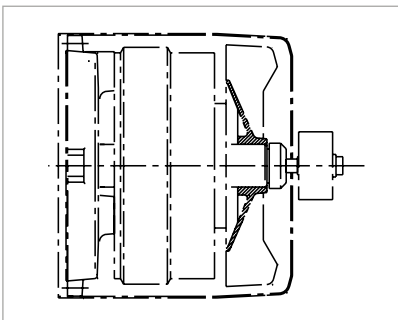

Special version
Type of cooling IC 411, self-ventilated with built-on brake and incremental encoder

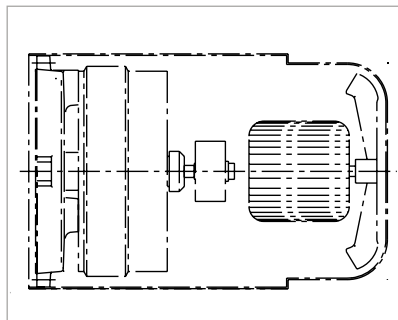

Special version
Type of cooling IC 416, forced ventilation with built-on brake and incremental encoder

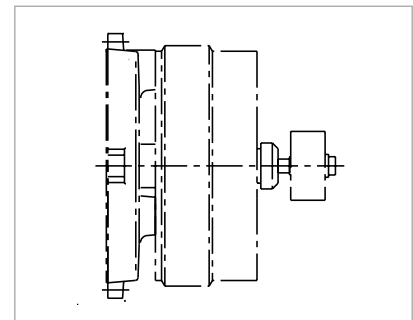

Special version
Type of cooling IC 410, non-ventilated with built-on brake and incremental encoder

Overview of available components

Forced ventilation

Forced ventilation provides for adequate motor cooling at low speeds in converter-fed operation and serves to avoid loud noise at running speeds significantly above the limit speed. The mounting of a fan unit for forced ventilation increases the length and weight of the motor. Binding information on the supply voltage, current and frequency is to be taken from the rating plate.

- Fan unit FBW (Wistro) for use with standard motors
- Fan unit FBI/MMP (Maier) for use with light-duty roller table motors

Brakes

The brakes are designed as spring-operated brakes and fulfil the function of a holding brake. The braking and holding of the motor shaft serves merely to suppress unintentional rotation due to external torques, e.g. the influence of crane loads. The brake function becomes effective at speed $n=0$.

The holding brake must not be used as an operating brake ($n > 0$).

The mounting of a brake increases the overall mass moment of inertia, as well as the length and weight of the motor. Binding information on the brake type, braking torque, supply voltage, frequency, current and thermal class is to be taken from the motor rating plate.

VEM standard brakes

Ex warehouse

Stromag, mounting kit BZFM/BZFA up to size 180

Standard brake motor with integrally mounted brake

Sizes 56 to 132

Stromag, brake BZFM V10, V11, V12 (mounting kit with integrated end shield and fan cowl) from sizes 160

Stromag, series BZFM V7 up to 380 Nm, > 380 Nm 4BZFM up to 4000 Nm

Optionally possible:

Stromag, series NFF, 20 to 10000 Nm

Intorq, series BFK 458, 1.5 to 600 Nm

Mayr, series M, 4 to 1600 Nm

Pintsch-Bubbenzer, series KFB, 50 to 1600 Nm

Pintsch-Bubbenzer, series SFB, 63 to 10000 Nm

Precima, series FDB, 2 to 1500 Nm

Incremental encoders

Ex warehouse

Baumer Thalheim

Type ITD 2. up to and including size 80

Type ITD 4. up to and including size 132

Leine & Linde

Type 861 from size 160 to 250

BEI IDEACOD Inc.

GHM 9 S11

Tacho generator

Johannes Hübner Fabrik elektrischer Maschinen GmbH

TDPH 439 60V with torque arm

Integrated freewheels (backstops)

RINGSPANN GmbH

FXM 66 NX without end cover

FXM 86 NX without end cover

FXM 100 SX with end cover

FXM 120 SX with end cover

Project-specific mounting

Baumer Thalheim GmbH & Co. KG

ITD 40 (radially attached cable 1 m, up to size 132 T 0.5 m)

ITD 41 (radially attached cable 1 m)

ITD 42 (radially attached cable 1 m)

ITD 70 (radially attached cable 1 m)

Baumer Hübner GmbH

Hübner HOG 10 + torque arm

Hübner HOG 9 + torque arm

Hübner POG 9 (centred mounting)

Hübner POG 10 (centred mounting)

Hübner FGJ 2

Brake assignments

2-pole Brake motors Built-on brake with squirrel-cage rotor; Stromag, Intorq brake

Premium Efficiency IE3/High Efficiency IE2/Standard Efficiency IE1 according to IEC/EN 60034-30-1

P _B P _B kW	For motor IE3-	For motor IE2-	For motor (IE1)-B.1R	For motor (IE1)-B.0R	Stromag BZFM	Nm	Stromag NFF	Nm	Intorq BFK	Nm
0.12	IE3-B.1R 56 G2	IE2-B.2R 56 G2	(IE1)-B.1R 56 G2	-	BZFM 0.25	3	-	-	BFK458-06	4
0.18	IE3-B.2R 63 K2	IE2-B.2R 63 K2	(IE1)-B.1R 63 K2	(IE1)-B.0R 56 K2	BZFM 0.25	3	-	-	BFK458-06	4
0.25	IE3-B.1R 63 G2	IE2-BE2R 63 G2	(IE1)-B.1R 63 G2	(IE1)-B.0R 56 G2	BZFM 0.25	3	-	-	BFK458-06	4
0.37	IE3-B.2R 71 K2	IE2-B.2R 71 K2	(IE1)-B.1R 71 K2	(IE1)-B.0R 63 K2	BZFM 0.25	3	-	-	-	-
0.37	IE3-B.2R 71 K2	IE2-B.2R 71 K2	(IE1)-B.1R 71 K2	(IE1)-B.0R 63 K2	BZFM 0.63	6.3	-	-	BFK458-06	4
0.55	-	IE2-B.2R 71 G2	(IE1)-B.1R 71 G2	(IE1)-B.0R 63 G2	BZFM 0.25	3	-	-	-	-
0.55	IE3-B.1R 71 GY2	IE2-B.2R 71 G2	(IE1)-B.1R 71 G2	(IE1)-B.0R 63 G2	BZFM 0.63	6.3	-	-	BFK458-06	4
0.75	-	-	(IE1)-B.1R 80 K2	(IE1)-B.0R 71 K2	BZFM 0.63	6.3	-	-	-	-
0.75	-	-	(IE1)-B.1R 80 K2	(IE1)-B.0R 71 K2	BZFM 1.6	13.5	-	-	BFK458-06	4
0.75	IE3-B.1R 80 K2	IE2-B.1R 80 K2	(IE1)-B.1R 80 K2	(IE1)-B.0R 71 K2	BZFM 1.6	13.5	-	-	BFK458-08	8
1.1	-	-	(IE1)-B.1R 80 G2	(IE1)-B.0R 71 G2	BZFM 0.63	6.3	-	-	-	-
1.1	-	-	(IE1)-B.1R 80 G2	(IE1)-B.0R 71 G2	BZFM 1.6	13.5	-	-	BFK458-06	4
1.1	IE3-B.1R 80 G2	IE2-B.1R 80 G2	(IE1)-B.1R 80 G2	(IE1)-B.0R 71 G2	BZFM 1.6	13.5	-	-	BFK458-08	8
1.5	-	-	(IE1)-B.1R 90 S2	(IE1)-B.0R 80 K2	BZFM 1.6	13.5	-	-	BFK458-06	4
1.5	-	-	(IE1)-B.1R 90 S2	(IE1)-B.0R 80 K2	BZFM 2.5	27	-	-	BFK458-08	8
1.5	IE3-B.1R 90 S2	IE2-B.1R 90 S2	(IE1)-B.1R 90 S2	(IE1)-B.0R 80 K2	BZFM 2.5	27	-	-	BFK458-10	16
2.2	-	-	(IE1)-B.1R 90 L2	(IE1)-B.0R 80 G2	BZFM 1.6	13.5	-	-	BFK458-06	4
2.2	-	-	(IE1)-B.1R 90 L2	(IE1)-B.0R 80 G2	BZFM 2.5	27	-	-	BFK458-08	8
2.2	IE3-B.1R 90 L2	IE2-B.1R 90 L2	(IE1)-B.1R 90 L2	(IE1)-B.0R 80 G2	BZFM 2.5	27	-	-	BFK458-10	16
3.0	-	-	(IE1)-B.1R 100 L2	(IE1)-B.0R 90 L2	BZFM 2.5	27	-	-	BFK458-08	8
3.0	-	-	(IE1)-B.1R 100 L2	(IE1)-B.0R 90 L2	BZFM 4	37	-	-	BFK458-10	16
3.0	IE3-B.1R 100 L2	IE2-B.1R 100 L2	(IE1)-B.1R 100 L2	(IE1)-B.0R 90 L2	BZFM 4	37	-	-	BFK458-12	32
4.0	-	-	(IE1)-B.1R 112 M2	(IE1)-B.0R 100 S2	BZFM 4	37	-	-	BFK458-10	16
4.0	-	-	(IE1)-B.1R 112 M2	(IE1)-B.0R 100 S2	BZFM 6.3	65	-	-	BFK458-12	32
4.0	IE3-B.1R 112 M2T	IE2-B.1R 112 MX2	(IE1)-B.1R 112 M2	(IE1)-B.0R 100 S2	BZFM 6.3	65	-	-	BFK458-14	60
5.5	-	-	(IE1)-B.1R 112 MX2	(IE1)-B.0R 100 L2	-	-	-	-	BFK458-10	16
5.5	-	-	(IE1)-B.1R 112 MX2	(IE1)-B.0R 100 L2	BZFM 4	37	-	-	BFK458-12	32
5.5	-	IE2-B.1R 112 MV2	(IE1)-B.1R 112 MX2	(IE1)-B.0R 100 L2	BZFM 6.3	65	-	-	BFK458-14	60
5.5	-	-	(IE1)-B.1R 132 S2T	(IE1)-B.0R 100 L2	BZFM 4	37	-	-	-	-
5.5	-	-	(IE1)-B.1R 132 S2T	(IE1)-B.0R 100 L2	BZFM 6.3	65	-	-	BFK458-12	32
5.5	-	IE2-B.1R 132 S2T	(IE1)-B.1R 132 S2T	(IE1)-B.0R 100 L2	BZFM 6.3	65	-	-	BFK458-14	60
7.5	-	-	(IE1)-B.1R 112 MV2	(IE1)-B.0R 100 LV2*)	BZFM 6.3	65	-	-	BFK458-12	32
7.5	-	-	(IE1)-B.1R 132 SX2T	(IE1)-B.0R 100 LV2*)	-	-	-	-	BFK458-12	32
7.5	-	-	(IE1)-B.1R 132 SX2T	(IE1)-B.0R 100 LV2*)	BZFM 6.3	65	-	-	BFK458-14	60
5.5	-	-	(IE1)-B.1R 132 S2 ¹⁾	(IE1)-B.0R 112 MY2 ¹⁾	BZFM 6.3	65	-	-	BFK458-12	32
5.5	IE3-B.1R 132 S2	-	(IE1)-B.1R 132 S2 ¹⁾	(IE1)-B.0R 112 MY2 ¹⁾	-	-	-	-	-	-
5.5	IE3-B.1R 132 S2	-	-	-	-	-	-	-	BFK458-14	60
7.5	-	-	(IE1)-B.1R 132 SX2 ¹⁾	(IE1)-B.0R 112 M2 ¹⁾	-	-	-	-	BFK458-12	32
7.5	-	-	(IE1)-B.1R 132 SX2 ¹⁾	(IE1)-B.0R 112 M2 ¹⁾	-	-	-	-	BFK458-12	60
7.5	IE3-B.1R 132 SX2	IE2-B.1R 132 SX2	(IE1)-B.1R 132 SX2 ¹⁾	(IE1)-B.0R 112 M2 ¹⁾	BZFM 6.3	65	-	-	BFK458-14	60
7.5	IE3-B.1R 132 SX2	-	-	-	-	-	-	-	-	-
11.0	-	-	(IE1)-B.1R 160 M2 ¹⁾	(IE1)-B.0R 132 M2 ¹⁾	-	-	-	-	-	-
11.0	IE3-B.1R 160 M2	IE2-B.1R 160 M2	-	-	-	-	-	-	-	-
11.0	-	IE2-B.1R 160 M2	(IE1)-B.1R 160 M2 ¹⁾	(IE1)-B.0R 132 M2 ¹⁾	-	-	NFF 10	100	-	-
11.0	IE3-B.1R 160 M2	IE2-B.1R 160 M2	(IE1)-B.1R 160 M2 ¹⁾	(IE1)-B.0R 132 M2 ¹⁾	BZFM 10	125	-	-	BFK458-16	80
15.0	-	IE2-B.1R 160 MX2	(IE1)-B.1R 160 MX2 ¹⁾	(IE1)-B.0R 160 S2 ¹⁾	-	-	-	-	-	-
15.0	IE3-B.1R 160 MX2	-	-	-	BZFM 10	125	-	-	-	-
15.0	-	IE2-B.1R 160 MX2	(IE1)-B.1R 160 MX2 ¹⁾	(IE1)-B.0R 160 S2 ¹⁾	-	-	-	-	-	-
15.0	IE3-B.1R 160 MX2	IE2-B.1R 160 MX2	(IE1)-B.1R 160 MX2 ¹⁾	(IE1)-B.0R 160 S2 ¹⁾	-	-	-	-	BFK458-18	150
18.5	IE3-B.1R 160 L2	-	-	-	BZFM 10	125	-	-	-	-
18.5	IE3-B.1R 160 L2	IE2-B.1R 160 L2	(IE1)-B.1R 160 L2 ¹⁾	(IE1)-B.0R 160 M2 ¹⁾	-	-	-	-	BFK458-18	150
15.0	-	IE2-B.1R 160 MX2	(IE1)-B.1R 160 MX2 ¹⁾	(IE1)-B.0R 160 S2 ¹⁾	BZFM 10	200	NFF 16	160	-	-
18.5	-	IE2-B.1R 160 L2	(IE1)-B.1R 160 L2 ¹⁾	(IE1)-B.0R 160 M2 ¹⁾	BZFM 16	200	NFF 16	160	-	-
22.0	IE3-B.1R 180 M2C	IE2-B.1R 180 M2	(IE1)-B.1R 180 M2 ¹⁾	(IE1)-B.0R 180 S2 ¹⁾	BZFM 16	200	NFF 25	250	BFK458-20	260
30.0	-	IE2-B.1R 200 L2	(IE1)-B.1R 200 L2 ¹⁾	(IE1)-B.0R 180 M2 ¹⁾	-	-	NFF 25	250	-	-
30.0	IE3-B.1R 200 L2	-	-	-	-	-	-	-	-	-
30.0	IE3-B.1R 200 L2	IE2-B.1R 200 L2	(IE1)-B.1R 200 L2 ¹⁾	(IE1)-B.0R 180 M2 ¹⁾	BZFM 25	380	-	-	BFK458-20	260
30.0	IE3-B.1R 200 LX2C	-	(IE1)-B.1R 200 LX2 ¹⁾	(IE1)-B.0R 200 M2 ¹⁾	-	-	-	-	-	-
37.0	-	-	(IE1)-B.1R 200 LX2 ¹⁾	(IE1)-B.0R 200 M2 ¹⁾	-	-	NFF 40	400	-	-
37.0	-	IE2-B.2R 200 LX2	-	-	-	-	NFF 25	250	-	-
37.0	-	IE2-B.2R 200 LX2	(IE1)-B.1R 200 LX2 ¹⁾	(IE1)-B.0R 200 M2 ¹⁾	-	-	-	-	BFK458-25	400
37.0	IE2-B.1R 200 LX2C	-	-	-	-	-	-	-	BFK458-20	260
37.0	IE3-B.1R 200 LX2C	IE2-B.2R 200 LX2	(IE1)-B.1R 200 LX2 ¹⁾	(IE1)-B.0R 200 M2 ¹⁾	BZFM 25	380	-	-	-	-

2-pole Brake motors Built-on brake with squirrel-cage rotor; Stromag, Intorq brake

Premium Efficiency IE3/High Efficiency IE2/Standard Efficiency IE1 according to IEC/EN 60034-30-1

P _B P _B kW	For motor IE3-	For motor IE2-	For motor (IE1-)B.1R	For motor (IE1-)B.0R	Stromag BZFM	Nm	Stromag NFF	Nm	Intorq BFK	Nm
45.0	-	IE2-B.1R 225 M2	(IE1-)B.1R 225 M2 ¹⁾	(IE1-)B.0R 200 L2 ¹⁾	-	-	NFF 40	400	-	-
45.0	IE3-B.1R 225 M2	-	-	-	-	-	-	-	-	-
45.0	IE3-B.1R 225 M2	IE2-B.1R 225 M2	(IE1-)B.1R 225 M2 ¹⁾	(IE1-)B.0R 200 L2 ¹⁾	BZFM 25	380	-	-	BFK458-25	400
55.0	-	IE2-B.1R 250 M2	(IE1-)B.1R 250 M2 ¹⁾	(IE1-)B.0R 225 M2 ¹⁾	4BZFM 40	400	NFF 63	630	-	-
55.0	IE3-B.1R 250 M2	-	-	-	4BZFM 63	630	-	-	-	-
55.0	IE3-B.1R 250 M2	IE2-B.1R 250 M2	(IE1-)B.1R 250 M2 ¹⁾	(IE1-)B.0R 225 M2 ¹⁾	-	-	-	-	BFK458-25	400
75.0	-	IE2-B.1R 280 S2	(IE1-)B.1R 280 S2 ¹⁾	(IE1-)B.0R 250 S2 ¹⁾	-	-	NFF 63	630	-	-
75.0	IE3-B.1R 280 S2	-	-	-	-	-	-	-	-	-
75.0	IE3-B.1R 280 S2	IE2-B.1R 280 S2	(IE1-)B.1R 280 S2 ¹⁾	(IE1-)B.0R 250 S2 ¹⁾	4BZFM 63	630	-	-	BFK458-25	400
90.0	-	IE2-B.1R 280 M2	(IE1-)B.1R 280 M2 ¹⁾	(IE1-)B.0R 250 M2 ¹⁾	-	-	NFF 100	1000	-	-
90.0	IE3-B.1R 280 M2	IE2-B.1R 280 M2	(IE1-)B.1R 280 M2 ¹⁾	(IE1-)B.0R 250 M2 ¹⁾	4BZFM 63	630	-	-	BFK458-25	400
90.0	IE3-B.1R 280 M2	-	-	-	-	-	-	-	-	-
110.0	-	IE2-B.1R 315 S2	(IE1-)B.1R 315 S2 ¹⁾	(IE1-)B.0R 280 S2 ¹⁾	-	-	NFF 100	1000	-	-
110.0	IE3-B.1R 315 S2	IE2-B.1R 315 S2	(IE1-)B.1R 315 S2 ¹⁾	(IE1-)B.0R 280 S2 ¹⁾	4BZFM 100	1000	-	-	-	-
132.0	-	IE2-B.1R 315 M2	(IE1-)B.1R 315 M2 ¹⁾	(IE1-)B.0R 280 M2 ¹⁾	-	-	NFF 100	1000	-	-
132.0	IE3-B.1R 315 M2	IE2-B.1R 315 M2	(IE1-)B.1R 315 M2 ¹⁾	(IE1-)B.0R 280 M2 ¹⁾	4BZFM 100	1000	-	-	-	-
160.0	-	IE2-B.1R 315 MX2	(IE1-)B.1R 315 MX2 ¹⁾	(IE1-)B.0R 315 S2 ¹⁾	-	-	NFF 100	1000	-	-
160.0	IE3-B.1R 315 MX2	IE2-B.1R 315 MX2	(IE1-)B.1R 315 MX2 ¹⁾	(IE1-)B.0R 315 S2 ¹⁾	4BZFM 100	1000	-	-	-	-
200.0	-	IE2-B.1R 315 MY2	(IE1-)B.1R 315 MY2 ¹⁾	(IE1-)B.0R 315 M2 ¹⁾	-	-	NFF 160	1600	-	-
200.0	IE3-B.1R 315 MY2	IE2-B.1R 315 MY2	(IE1-)B.1R 315 MY2 ¹⁾	(IE1-)B.0R 315 M2 ¹⁾	4BZFM 160	1600	-	-	-	-
250.0	-	IE2-B.1R 315 L2	(IE1-)B.1R 315 L2 ¹⁾	(IE1-)B.0R 315 L2 ¹⁾	-	-	NFF 160	1600	-	-
250.0	IE3-B.1R 315 L2	IE2-B.1R 315 L2	(IE1-)B.1R 315 L2 ¹⁾	(IE1-)B.0R 315 L2 ¹⁾	4BZFM 160	1600	-	-	-	-
315.0	-	IE2-B.1R 315 LX2	(IE1-)B.1R 315 LX2 ¹⁾	(IE1-)B.0R 315 LX2 ¹⁾	-	-	NFF 160	1600	-	-
315.0	IE3-B.1R 315 LX2	IE2-B.1R 315 LX2	(IE1-)B.1R 315 LX2 ¹⁾	(IE1-)B.0R 315 LX2 ¹⁾	4BZFM 160	1600	-	-	-	-
315.0	-	IE2-B.2R 355 MY2	(IE1-)B.2R 355 MY2 ¹⁾	-	-	-	-	-	-	-
315.0	-	IE2-B.2R 355 MY2	(IE1-)B.2R 355 MY2 ¹⁾	-	-	-	NFF 160	1600	-	-
355.0	-	IE2-B.2R 355 M2	(IE1-)B.2R 355 M2 ¹⁾	-	-	-	NFF 160	1600	-	-
355.0	IE3-B.1R 355 M2	IE2-B.2R 355 M2	(IE1-)B.2R 355 M2 ¹⁾	-	4BZFM 160	1600	-	-	-	-
400.0	-	IE2-B.2R 355 MX2	(B.2R 355 MX2 ¹⁾	-	-	-	NFF 160	1600	-	-
400.0	IE3-B.2R 355 MX2	IE2-B.2R 355 MX2	(B.2R 355 MX2 ¹⁾	-	4BZFM 160	1600	-	-	-	-
450.0	-	-	B.2R 355 LY2 ¹⁾	-	-	-	NFF 160	1600	-	-
500.0	-	-	B.2R 355 L2 ¹⁾	-	-	-	NFF 160	1600	-	-
500.0	IE3-B.2R 355 L2	IE2-B.2R 355 L2	B.2R 355 L2 ¹⁾	-	4BZFM 160	1600	-	-	-	-
560.0	IE3-B.2R 400 M2	-	-	-	-	-	-	-	-	-
630.0	IE3-B.2R 400 MX2	-	-	-	-	-	-	-	-	-
710.0	IE3-B.2R 400 L2	-	-	-	-	-	-	-	-	-

Corresponding basic version plus brake and brake mounting (see Extra price list)

Sizes 56–132 T plus rectifier (see Brake accessories)

¹⁾ Flange version only

¹⁾ Requires consultation regarding application

(IE1-) can be supplied with and without marking of IE classification

2-pole Brake motors

Built-on brake with squirrel-cage rotor; Mayr, Pintsch-Bubbenzer, Precima brake

Premium Efficiency IE3/High Efficiency IE2/Standard Efficiency IE1 according to IEC/EN 60034-30-1

P _B P _B KW	For motor IE3-	For motor IE2-	For motor (IE1-)B.1R	For motor (IE1-)B.0R	Mayr M 800/891 (IP 65)	Nm	Pintsch-Bubbenzer KFB/SFB	Nm	Precima FDB	Nm
0.12	IE3-B.1R 56 G2	IE2-B.2R 56 G2	(IE1-)B.1R 56 G2	-	M2/891.	4	-	-	***	***
0.18	IE3-B.2R 63 K2	IE2-B.2R 63 K2	(IE1-)B.1R 63 K2	(IE1-)B.0R 56 K2	M2/891.	4	-	-	***	***
0.25	IE3-B.1R 63 G2	IE2-BE2R 63 G2	(IE1-)B.1R 63 G2	(IE1-)B.0R 56 G2	M2/891.	4	-	-	***	***
0.37	IE3-B.2R 71 K2	IE2-B.2R 71 K2	(IE1-)B.1R 71 K2	(IE1-)B.0R 63 K2	-	-	-	-	***	***
0.37	IE3-B.2R 71 K2	IE2-B.2R 71 K2	(IE1-)B.1R 71 K2	(IE1-)B.0R 63 K2	M4/891.	4	-	-	***	***
0.55	-	IE2-B.2R 71 G2	(IE1-)B.1R 71 G2	(IE1-)B.0R 63 G2	-	-	-	-	***	***
0.55	IE3-B.1R 71 GY2	IE2-B.2R 71 G2	(IE1-)B.1R 71 G2	(IE1-)B.0R 63 G2	M4/891.	4	-	-	***	***
0.75	-	-	(IE1-)B.1R 80 K2	(IE1-)B.0R 71 K2	-	-	-	-	***	***
0.75	-	-	(IE1-)B.1R 80 K2	(IE1-)B.0R 71 K2	-	-	-	-	***	***
0.75	IE3-B.1R 80 K2	IE2-B.1R 80 K2	(IE1-)B.1R 80 K2	(IE1-)B.0R 71 K2	M8/891.	8	-	-	***	***
1.1	-	-	(IE1-)B.1R 80 G2	(IE1-)B.0R 71 G2	-	-	-	-	***	***
1.1	-	-	(IE1-)B.1R 80 G2	(IE1-)B.0R 71 G2	-	-	-	-	***	***
1.1	IE3-B.1R 80 G2	IE2-B.1R 80 G2	(IE1-)B.1R 80 G2	(IE1-)B.0R 71 G2	M8/891.	8	-	-	***	***
1.5	-	-	(IE1-)B.1R 90 S2	(IE1-)B.0R 80 K2	-	-	-	-	***	***
1.5	-	-	(IE1-)B.1R 90 S2	(IE1-)B.0R 80 K2	-	-	-	-	***	***
1.5	IE3-B.1R 90 S2	IE2-B.1R 90 S2	(IE1-)B.1R 90 S2	(IE1-)B.0R 80 K2	M16/891.	16	-	-	***	***
2.2	-	-	(IE1-)B.1R 90 L2	(IE1-)B.0R 80 G2	-	-	-	-	***	***
2.2	-	-	(IE1-)B.1R 90 L2	(IE1-)B.0R 80 G2	-	-	-	-	***	***
2.2	IE3-B.1R 90 L2	IE2-B.1R 90 L2	(IE1-)B.1R 90 L2	(IE1-)B.0R 80 G2	M16/891.	16	-	-	***	***
3.0	-	-	(IE1-)B.1R 100 L2	(IE1-)B.0R 90 L2	-	-	-	-	***	***
3.0	-	-	(IE1-)B.1R 100 L2	(IE1-)B.0R 90 L2	-	-	-	-	***	***
3.0	IE3-B.1R 100 L2	IE2-B.1R 100 L2	(IE1-)B.1R 100 L2	(IE1-)B.0R 90 L2	M32/891.	32	-	-	***	***
4.0	-	-	(IE1-)B.1R 112 M2	(IE1-)B.0R 100 S2	-	-	-	-	***	***
4.0	-	-	(IE1-)B.1R 112 M2	(IE1-)B.0R 100 S2	-	-	-	-	***	***
4.0	IE3-B.1R 112 M2T	IE2-B.1R 112 MX2	(IE1-)B.1R 112 M2	(IE1-)B.0R 100 S2	M60/891.	60	-	-	***	***
5.5	-	-	(IE1-)B.1R 112 MX2	(IE1-)B.0R 100 L2	-	-	-	-	***	***
5.5	-	-	(IE1-)B.1R 112 MX2	(IE1-)B.0R 100 L2	-	-	-	-	***	***
5.5	-	IE2-B.1R 112 MV2	(IE1-)B.1R 112 MX2	(IE1-)B.0R 100 L2	M60/891.	60	-	-	***	***
5.5	-	-	(IE1-)B.1R 132 S2T	(IE1-)B.0R 100 L2	-	-	-	-	***	***
5.5	-	-	(IE1-)B.1R 132 S2T	(IE1-)B.0R 100 L2	-	-	-	-	***	***
5.5	-	IE2-B.1R 132 S2T	(IE1-)B.1R 132 S2T	(IE1-)B.0R 100 L2	M60/891.	60	-	-	***	***
7.5	-	-	(IE1-)B.1R 112 MV2	(IE1-)B.0R 100 LV2*)	M60/891.	60	-	-	***	***
7.5	-	-	(IE1-)B.1R 132 SX2T	(IE1-)B.0R 100 LV2*)	-	-	-	-	***	***
7.5	-	-	(IE1-)B.1R 132 SX2T	(IE1-)B.0R 100 LV2*)	M60/891.	60	-	-	***	***
5.5	-	-	(IE1-)B.1R 132 S2 ¹⁾	(IE1-)B.0R 112 MY2 ¹⁾	-	-	-	-	FDB 15	40
5.5	IE3-B.1R 132 S2	-	(IE1-)B.1R 132 S2 ¹⁾	(IE1-)B.0R 112 MY2 ¹⁾	M32/891.100.1	40	-	-	-	-
5.5	IE3-B.1R 132 S2	-	-	-	-	-	KFB 5	50	FDB 17	60
7.5	-	-	(IE1-)B.1R 132 SX2 ¹⁾	(IE1-)B.0R 112 M2 ¹⁾	-	-	-	-	FDB 15	40
7.5	-	-	(IE1-)B.1R 132 SX2 ¹⁾	(IE1-)B.0R 112 M2 ¹⁾	-	-	-	-	FDB 15	40
7.5	IE3-B.1R 132 SX2	IE2-B.1R 132 SX2	(IE1-)B.1R 132 SX2 ¹⁾	(IE1-)B.0R 112 M2 ¹⁾	M32/891.100.1	64	-	-	FDB 17	60
7.5	IE3-B.1R 132 SX2	-	-	-	-	-	KFB 10	100	-	-
11.0	-	-	(IE1-)B.1R 160 M2 ¹⁾	(IE1-)B.0R 132 M2 ¹⁾	M32/891.100.1	64	-	-	-	-
11.0	IE3-B.1R 160 M2	IE2-B.1R 160 M2	-	-	M60/891.100.1	100	-	-	-	-
11.0	-	IE2-B.1R 160 M2	(IE1-)B.1R 160 M2 ¹⁾	(IE1-)B.0R 132 M2 ¹⁾	-	-	-	-	-	-
11.0	IE3-B.1R 160 M2	IE2-B.1R 160 M2	(IE1-)B.1R 160 M2 ¹⁾	(IE1-)B.0R 132 M2 ¹⁾	-	-	KFB 10	100	FDB 20	100
15.0	-	IE2-B.1R 160 MX2	(IE1-)B.1R 160 MX2 ¹⁾	(IE1-)B.0R 160 S2 ¹⁾	-	-	-	-	-	-
15.0	IE3-B.1R 160 MX2	-	-	-	-	-	KFB 10	100	-	-
15.0	-	IE2-B.1R 160 MX2	(IE1-)B.1R 160 MX2 ¹⁾	(IE1-)B.0R 160 S2 ¹⁾	-	-	KFB 16	160	-	-
15.0	IE3-B.1R 160 MX2	IE2-B.1R 160 MX2	(IE1-)B.1R 160 MX2 ¹⁾	(IE1-)B.0R 160 S2 ¹⁾	M60/891.100.1	100	-	-	FDB 23	150
18.5	IE3-B.1R 160 L2	-	-	-	-	-	KFB 30	175	-	-
18.5	IE3-B.1R 160 L2	IE2-B.1R 160 L2	(IE1-)B.1R 160 L2 ¹⁾	(IE1-)B.0R 160 M2 ¹⁾	M100/891.100.1	180	-	-	FDB 23	150
15.0	-	IE2-B.1R 160 MX2	(IE1-)B.1R 160 MX2 ¹⁾	(IE1-)B.0R 160 S2 ¹⁾	-	-	-	-	-	-
18.5	-	IE2-B.1R 160 L2	(IE1-)B.1R 160 L2 ¹⁾	(IE1-)B.0R 160 M2 ¹⁾	-	-	KFB 16	160	-	-
22.0	IE3-B.1R 180 M2C	IE2-B.1R 180 M2	(IE1-)B.1R 180 M2 ¹⁾	(IE1-)B.0R 180 S2 ¹⁾	M150/891.100.1	150	KFB 30	300	FDB 26	250
30.0	-	IE2-B.1R 200 L2	(IE1-)B.1R 200 L2 ¹⁾	(IE1-)B.0R 180 M2 ¹⁾	M150/891.100.1	250	-	-	-	-
30.0	IE3-B.1R 200 L2	-	-	-	M250/891.100.1	250	-	-	-	-
30.0	IE3-B.1R 200 L2	IE2-B.1R 200 L2	(IE1-)B.1R 200 L2 ¹⁾	(IE1-)B.0R 180 M2 ¹⁾	-	-	KFB 30	300	FDB 26	250
30.0	IE3-B.1R 200 LX2C	-	(IE1-)B.1R 200 LX2 ¹⁾	(IE1-)B.0R 200 M2 ¹⁾	M250/891.100.1	310	-	-	-	-
37.0	-	-	(IE1-)B.1R 200 LX2 ¹⁾	(IE1-)B.0R 200 M2 ¹⁾	-	-	-	-	-	-
37.0	-	IE2-B.2R 200 LX2	-	-	M150/891.100.1	250	-	-	-	-
37.0	-	IE2-B.2R 200 LX2	(IE1-)B.1R 200 LX2 ¹⁾	(IE1-)B.0R 200 M2 ¹⁾	-	-	KFB 40	400	FDB 30	400
37.0	IE2-B.1R 200 LX2C	-	-	-	-	-	KFB 30	300	-	-
37.0	IE3-B.1R 200 LX2C	IE2-B.2R 200 LX2	(IE1-)B.1R 200 LX2 ¹⁾	(IE1-)B.0R 200 M2 ¹⁾	-	-	-	-	-	-

4-pole Brake motors Built-on brake with squirrel-cage rotor; Mayr, Pintsch-Bubbenzer, Precima brake

Premium Efficiency IE3/High Efficiency IE2/Standard Efficiency IE1 according to IEC/EN 60034-30-1

P _B P _B KW	For motor IE3-	For motor IE2-	For motor (IE1-)B.1R	For motor (IE1-)B.0R	Mayr M 800/891 (IP 65)	Nm	Pintsch-Bubbenzer KFB/SFB	Nm	Precima FDB	Nm
45.0	-	IE2-B.1R 225 M2	(IE1-)B.1R 225 M2 ¹⁾	(IE1-)B.0R 200 L2 ¹⁾	M250/891.100.1	310	-	-	-	-
45.0	IE3-B.1R 225 M2	-	-	-	M500/891.100.1	500	-	-	-	-
45.0	IE3-B.1R 225 M2	IE2-B.1R 225 M2	(IE1-)B.1R 225 M2 ¹⁾	(IE1-)B.0R 200 L2 ¹⁾	-	-	KFB 40	400	FDB 30	400
55.0	-	IE2-B.1R 250 M2	(IE1-)B.1R 250 M2 ¹⁾	(IE1-)B.0R 225 M2 ¹⁾	-	-	-	-	-	-
55.0	IE3-B.1R 250 M2	-	-	-	-	-	-	-	-	-
55.0	IE3-B.1R 250 M2	IE2-B.1R 250 M2	(IE1-)B.1R 250 M2 ¹⁾	(IE1-)B.0R 225 M2 ¹⁾	M500/891.100.1	500	KFB 63	630	FDB 30	400
75.0	-	IE2-B.1R 280 S2	(IE1-)B.1R 280 S2 ¹⁾	(IE1-)B.0R 250 S2 ¹⁾	-	-	-	-	-	-
75.0	IE3-B.1R 280 S2	-	-	-	-	-	-	-	-	-
75.0	IE3-B.1R 280 S2	IE2-B.1R 280 S2	(IE1-)B.1R 280 S2 ¹⁾	(IE1-)B.0R 250 S2 ¹⁾	-	-	KFB 63	630	FDB 30	400
90.0	-	IE2-B.1R 280 M2	(IE1-)B.1R 280 M2 ¹⁾	(IE1-)B.0R 250 M2 ¹⁾	-	-	KFB 100	1000	-	-
90.0	IE3-B.1R 280 M2	IE2-B.1R 280 M2	(IE1-)B.1R 280 M2 ¹⁾	(IE1-)B.0R 250 M2 ¹⁾	-	-	-	-	FDB 30	400
90.0	IE3-B.1R 280 M2	-	-	-	-	-	KFB 63	630	-	-
110.0	-	IE2-B.1R 315 S2	(IE1-)B.1R 315 S2 ¹⁾	(IE1-)B.0R 280 S2 ¹⁾	-	-	-	-	-	-
110.0	IE3-B.1R 315 S2	IE2-B.1R 315 S2	(IE1-)B.1R 315 S2 ¹⁾	(IE1-)B.0R 280 S2 ¹⁾	-	-	KFB 100	1000	-	-
132.0	-	IE2-B.1R 315 M2	(IE1-)B.1R 315 M2 ¹⁾	(IE1-)B.0R 280 M2 ¹⁾	-	-	-	-	-	-
132.0	IE3-B.1R 315 M2	IE2-B.1R 315 M2	(IE1-)B.1R 315 M2 ¹⁾	(IE1-)B.0R 280 M2 ¹⁾	-	-	KFB 100	1000	-	-
160.0	-	IE2-B.1R 315 MX2	(IE1-)B.1R 315 MX2 ¹⁾	(IE1-)B.0R 315 S2 ¹⁾	-	-	-	-	-	-
160.0	IE3-B.1R 315 MX2	IE2-B.1R 315 MX2	(IE1-)B.1R 315 MX2 ¹⁾	(IE1-)B.0R 315 S2 ¹⁾	-	-	KFB 100	1000	-	-
200.0	-	IE2-B.1R 315 MY2	(IE1-)B.1R 315 MY2 ¹⁾	(IE1-)B.0R 315 M2 ¹⁾	-	-	-	-	-	-
200.0	IE3-B.1R 315 MY2	IE2-B.1R 315 MY2	(IE1-)B.1R 315 MY2 ¹⁾	(IE1-)B.0R 315 M2 ¹⁾	-	-	KFB 160	1600	-	-
250.0	-	IE2-B.1R 315 L2	(IE1-)B.1R 315 L2 ¹⁾	(IE1-)B.0R 315 L2 ¹⁾	-	-	-	-	-	-
250.0	IE3-B.1R 315 L2	IE2-B.1R 315 L2	(IE1-)B.1R 315 L2 ¹⁾	(IE1-)B.0R 315 L2 ¹⁾	-	-	KFB 160	1600	-	-
315.0	-	IE2-B.1R 315 LX2	(IE1-)B.1R 315 LX2 ¹⁾	(IE1-)B.0R 315 LX2 ¹⁾	-	-	-	-	-	-
315.0	IE3-B.1R 315 LX2	IE2-B.1R 315 LX2	(IE1-)B.1R 315 LX2 ¹⁾	(IE1-)B.0R 315 LX2 ¹⁾	-	-	KFB 160	1600	-	-
315.0	-	IE2-B.2R 355 MY2	(IE1-)B.2R 355 MY2 ¹⁾	-	-	-	KFB 160	1600	-	-
315.0	-	IE2-B.2R 355 MY2	(IE1-)B.2R 355 MY2 ¹⁾	(IE1-)B.0R 280 M2 ¹⁾	-	-	-	-	-	-
355.0	-	IE2-B.2R 355 M2	(IE1-)B.2R 355 M2 ¹⁾	-	-	-	-	-	-	-
355.0	IE3-B.1R 355 M2	IE2-B.2R 355 M2	(IE1-)B.2R 355 M2 ¹⁾	-	-	-	KFB 160	1600	-	-
400.0	-	IE2-B.2R 355 MX2	(B.2R 355 MX2 ¹⁾	-	-	-	-	-	-	-
400.0	IE3-B.2R 355 MX2	IE2-B.2R 355 MX2	(B.2R 355 MX2 ¹⁾	-	-	-	KFB 160	1600	-	-
450.0	-	-	B.2R 355 LY2 ¹⁾	-	-	-	KFB 160	1600	-	-
500.0	-	-	B.2R 355 L2 ¹⁾	-	-	-	-	-	-	-
500.0	IE3-B.2R 355 L2	IE2-B.2R 355 L2	B.2R 355 L2 ¹⁾	-	-	-	KFB 160	1600	-	-
560.0	IE3-B.2R 400 M2	-	-	-	-	-	-	-	-	-
630.0	IE3-B.2R 400 MX2	-	-	-	-	-	-	-	-	-
710.0	IE3-B.2R 400 L2	-	-	-	-	-	-	-	-	-

Corresponding basic version plus brake and brake mounting (see Extra price list)

Sizes 56–132 T plus rectifier (see Brake accessories)

*) Flange version only

¹⁾ Requires consultation regarding application

(IE1-) can be supplied with and without marking of IE classification

***) upon request

4-pole Brake motors Built-on brake with squirrel-cage rotor; Stromag, Intorq brake

Premium Efficiency IE3/High Efficiency IE2/Standard Efficiency IE1 according to IEC/EN 60034-30-1

P _B P _B KW	For motor IE3-	For motor IE2-	For motor (IE1-)B.1R	For motor (IE1-)B.0R	Stromag BZFM	Nm	Stromag NFF	Nm	Intorq BFK	Nm
0.09	-	-	(IE1-)B.1R 56 G4	-	BZFM 0.25	3	-	-	BFK458-06	4
0.12	IE3-B.2R 63 K4	IE2-BE.2R 63 K4	(IE1-)B.1R 63 K4	(IE1-)B.0R 56 G4	BZFM 0.25	3	-	-	BFK458-06	4
0.18	IE3-B.2R 71 K4	IE2-BE.1R 63 GY4	(IE1-)B.1R 63 G4	(IE1-)B.0R 56 G4	BZFM 0.25	3	-	-	BFK458-06	4
0.25	IE3-B.2R 71 K4	IE2-B.2R 71 K4	(IE1-)B.1R 71 K4	(IE1-)B.0R 63 K4	BZFM 0.25	3	-	-	BFK458-06	4
0.25	IE3-B.2R 71 K4	IE2-B.2R 71 K4	(IE1-)B.1R 71 K4	(IE1-)B.0R 63 K4	BZFM 0.63	6.3	-	-	-	-
0.37	IE3-B.1R 71 GY4	IE2-B.1R 71 GY4	(IE1-)B.1R 71 G4	(IE1-)B.0R 63 G4	BZFM 0.25	3	-	-	BFK458-06	4
0.37	-	-	(IE1-)B.1R 71 G4	(IE1-)B.0R 63 G4	BZFM 0.63	6.3	-	-	-	-
0.55	-	IE2-B.2R 80 K4	(IE1-)B.1R 80 K4	(IE1-)B.0R 71 K4	BZFM 0.63	6.3	-	-	BFK458-06	4
0.55	IE3-B.1R 80 K4	-	(IE1-)B.1R 80 K4	(IE1-)B.0R 71 K4	BZFM 1.6	13.5	-	-	BFK458-08	8
0.75	-	-	(IE1-)B.1R 80 G4	(IE1-)B.0R 71 G4	BZFM 0.63	6.3	-	-	BFK458-06	4
0.75	IE3-B.1R 80 GX4	IE2-B.1R 80 G4	(IE1-)B.1R 80 G4	(IE1-)B.0R 71 G4	BZFM 1.6	13.5	-	-	BFK458-08	8
0.9	-	-	(IE1-)B.1R 80 GX4	(IE1-)B.0R 71 GX4	-	-	-	-	BFK458-06	4
0.9	-	-	(IE1-)B.1R 80 GX4	(IE1-)B.0R 71 GX4	-	-	-	-	BFK458-08	8
1.1	-	-	(IE1-)B.1R 90 S4	(IE1-)B.0R 80 K4	BZFM 1.6	13.5	-	-	BFK458-06	4
1.1	-	-	(IE1-)B.1R 90 S4	(IE1-)B.0R 80 K4	-	-	-	-	BFK458-08	8
1.1	IE3-B.1R 90 S4	IE2-B.1R 90 S4	(IE1-)B.1R 90 S4	(IE1-)B.0R 80 K4	BZFM 2.5	27	-	-	BFK458-10	16
1.5	-	-	(IE1-)B.1R 90 L4	(IE1-)B.0R 80 G4	BZFM 1.6	13.5	-	-	BFK458-06	4
1.5	-	-	(IE1-)B.1R 90 L4	(IE1-)B.0R 80 G4	-	-	-	-	BFK458-08	8
1.5	IE3-B.1R 90 LX4	IE2-B.1R 90 L4	(IE1-)B.1R 90 L4	(IE1-)B.0R 80 G4	BZFM 2.5	27	-	-	BFK458-10	16
2.2	-	-	(IE1-)B.1R 100 L4	(IE1-)B.0R 90 L4	BZFM 2.5	27	-	-	BFK458-08	8
2.2	-	-	(IE1-)B.1R 100 L4	(IE1-)B.0R 90 L4	-	-	-	-	BFK458-10	16
2.2	IE3-B.1R 100 L4	IE2-B.1R 100 L4	(IE1-)B.1R 100 L4	(IE1-)B.0R 90 L4	BZFM 4	37	-	-	BFK458-12	32
3.0	-	-	(IE1-)B.1R 100 LX4	(IE1-)B.0R 100 S4	-	-	-	-	BFK458-10	16
3.0	IE3-B.1R 100 LZ4	IE2-B.1R 100 LX4	(IE1-)B.1R 100 LX4	(IE1-)B.0R 100 S4	BZFM 4	37	-	-	BFK458-12	32
3.0	-	-	(IE1-)B.1R 100 LX4	(IE1-)B.0R 100 S4	BZFM 6.3	65	-	-	BFK458-14	60
4.0	-	-	(IE1-)B.1R 112 M4	(IE1-)B.0R 100 L4	-	-	-	-	BFK458-10	16
4.0	-	-	(IE1-)B.1R 112 M4	(IE1-)B.0R 100 L4	BZFM 4	37	-	-	BFK458-12	32
4.0	IE3-B.1R 112 M4	IE2-B.1R 112 MZ4	(IE1-)B.1R 112 M4	(IE1-)B.0R 100 L4	BZFM 6.3	65	-	-	BFK458-14	60
5.5	-	-	(IE1-)B.1R 112 MX4	(IE1-)B.0R 100 LX4*)	BZFM 4	37	-	-	BFK458-10	16
5.5	-	-	(IE1-)B.1R 112 MX4	(IE1-)B.0R 100 LX4*)	BZFM 6.3	65	-	-	BFK458-12	32
5.5	-	-	(IE1-)B.1R 112 MX4	(IE1-)B.0R 100 LX4*)	-	-	-	-	BFK458-14	60
5.5	-	-	(IE1-)B.1R 132 S4T	(IE1-)B.0R 100 LX4*)	BZFM 4	37	-	-	BFK458-12	32
5.5	-	-	(IE1-)B.1R 132 S4T	(IE1-)B.0R 100 LX4*)	BZFM 6.3	65	-	-	BFK458-14	60
5.5	IE3-B.1R 132 S4	IE2-B.2R 132 S4	(IE1-)B.1R 132 S4	(IE1-)B.0R 112 M4	BZFM 6.3	65	-	-	BFK458-16	80
7.5	-	IE2-B.1R 132 M4	(IE1-)B.1R 132 M4	(IE1-)B.0R 132 S4	-	-	NFF 10	100	-	-
7.5	IE3-B.1R 132 M4	IE2-B.1R 132 M4	(IE1-)B.1R 132 M4	(IE1-)B.0R 132 S4	BZFM 10	125	-	-	BFK458-16	90
11.0	-	IE2-B.2R 160 M4	(IE1-)B.1R 160 M4	(IE1-)B.0R 132 M4	-	-	NFF 10	100	-	-
11.0	IE3-B.1R 160 M4	IE2-B.2R 160 M4	(IE1-)B.1R 160 M4	(IE1-)B.0R 132 M4	BZFM 16	200	-	-	-	-
11.0	IE3-B.1R 160 M4	-	-	-	-	-	-	-	-	-
15.0	-	-	(IE1-)B.1R 160 L4	(IE1-)B.0R 160 S4	BZFM 16	200	NFF 25	250	BFK458-20	260
15.0	-	IE2-B.2R 160 L4	-	-	-	-	NFF 16	160	-	-
15.0	-	IE2-B.2R 160 L4	(IE1-)B.1R 160 L4	(IE1-)B.0R 160 S4	-	-	-	-	-	-
15.0	IE3-B.1R 160 L4C	-	-	-	-	-	-	-	-	-
15.0	IE3-B.1R 160 L4C	IE2-B.2R 160 L4	-	-	BZFM 16	250	-	-	BFK458-20	260
18.5	-	IE2-B.2R 180 M4	(IE1-)B.1R 180 M4	(IE1-)B.0R 160 M4	-	-	NFF 25	250	-	-
18.5	IE3-B.1R 180 M4	IE2-B.2R 180 M4	(IE1-)B.1R 180 M4	(IE1-)B.0R 160 M4	BZFM 16	250	-	-	BFK458-20	260
22.0	-	-	(IE1-)B.1R 180 L4	(IE1-)B.0R 180 S4	-	-	NFF 40	400	BFK458-25	400
22.0	-	IE2-B.1R 180 L4	-	-	-	-	NFF 25	250	BFK458-25	400
22.0	IE3-B.1R 180 L4	-	-	-	-	-	-	-	BFK458-20	290
22.0	-	IE2-B.1R 180 L4	(IE1-)B.1R 180 L4	(IE1-)B.0R 180 S4	-	-	-	-	-	-
22.0	IE3-B.1R 180 L4	IE2-B.1R 180 L4	(IE1-)B.1R 180 L4	(IE1-)B.0R 180 S4	BZFM 25	380	-	-	-	-
30.0	-	IE2-B.1R 200 L4	(IE1-)B.1R 200 L4	(IE1-)B.0R 180 M4	-	-	NFF 40	400	-	-
30.0	IE3-B.1R 200 L4C	-	-	-	-	-	-	-	-	-
30.0	IE3-B.1R 200 L4C	IE2-B.1R 200 L4	(IE1-)B.1R 200 L4	(IE1-)B.0R 180 M4	BZFM 25	380	-	-	BFK458-25	400
37.0	-	-	(IE1-)B.1R 225 S4	(IE1-)B.0R 200 M4	-	-	NFF 63	630	-	-
37.0	-	IE2-B.1R 225 S4	-	-	-	-	NFF 40	400	-	-
37.0	IE3-B.1R 225 S4C	IE2-B.1R 225 S4	(IE1-)B.1R 225 S4	(IE1-)B.0R 200 M4	BZFM 25	380	-	-	BFK458-25	400
37.0	IE3-B.1R 225 S4C	-	-	-	-	-	-	-	-	-
45.0	-	-	(IE1-)B.1R 225 M4	(IE1-)B.0R 200 L4	-	-	NFF 63	630	-	-
45.0	-	IE2-B.1R 225 M4	-	-	-	-	NFF 40	400	-	-
45.0	IE3-B.1R 225 M4	-	-	-	-	-	-	-	-	-
45.0	IE3-B.1R 225 M4	IE2-B.1R 225 M4	(IE1-)B.1R 225 M4	(IE1-)B.0R 200 L4	BZFM 25	380	-	-	BFK458-25	400

4-pole Brake motors Built-on brake with squirrel-cage rotor; Stromag, Intorq brake

Premium Efficiency IE3/High Efficiency IE2/Standard Efficiency IE1 according to IEC/EN 60034-30-1

P _B P _B KW	For motor IE3-	For motor IE2-	For motor (IE1-)B.1R	For motor (IE1-)B.0R	Stromag BZFM	Nm	Stromag NFF	Nm	Intorq BFK	Nm
55.0	-	IE2-B.1R 250 M4	(IE1-)B.1R 250 M4	(IE1-)B.0R 225 M4	-	-	NFF 100	1000	-	-
55.0	IE3-B.1R 250 M4	IE2-B.1R 250 M4	-	-	4BZFM 63	630	-	-	BFK458-25	400
55.0	IE3-B.1R 250 M4	-	-	-	-	-	-	-	-	-
55.0	IE3-B.1R 250 M4	-	-	-	-	-	-	-	-	-
55.0	-	IE2-B.1R 250 M4	-	-	-	-	-	-	-	-
55.0	-	-	(IE1-)B.1R 250 M4	(IE1-)B.0R 225 M4	4BZFM 63	800	-	-	BFK458-25	400
75.0	-	IE2-B.1R 280 S4	(IE1-)B.1R 280 S4	(IE1-)B.0R 250 S4	-	-	NFF 100	1000	-	-
75.0	IE3-B.1R 280 S4	IE2-B.1R 280 S4	(IE1-)B.1R 280 S4	(IE1-)B.0R 250 S4	4BZFM 63	800	-	-	BFK458-25	400
75.0	IE3-B.1R 280 S4	-	-	-	-	-	-	-	-	-
90.0	-	-	(IE1-)B.1R 280 M4	(IE1-)B.0R 250 M4	-	-	-	-	-	-
90.0	-	IE2-B.1R 280 M4	-	-	-	-	-	-	-	-
90.0	-	IE2-B.1R 280 M4	(IE1-)B.1R 280 M4	(IE1-)B.0R 250 M4	-	-	NFF 100	1000	BFK458-25	400
90.0	IE3-B.1R 280 M4	-	-	-	-	-	-	-	-	-
90.0	IE3-B.1R 280 M4	IE2-B.1R 280 M4	(IE1-)B.1R 280 M4	(IE1-)B.0R 250 M4	4BZFM 100	1000	-	-	-	-
110.0	-	IE2-B.1R 315 S4	(IE1-)B.1R 315 S4	(IE1-)B.0R 280 S4	-	-	NFF 160	1600	-	-
110.0	IE3-B.1R 315 S4	IE2-B.1R 315 S4	(IE1-)B.1R 315 S4	(IE1-)B.0R 280 S4	4BZFM 100	1000	-	-	-	-
110.0	IE3-B.1R 315 S4	-	-	-	-	-	-	-	-	-
132.0	-	IE2-B.1R 315 M4	(IE1-)B.1R 315 M4	(IE1-)B.0R 280 M4	-	-	NFF 160	1600	-	-
132.0	IE3-B.1R 315 M4	IE2-B.1R 315 M4	(IE1-)B.1R 315 M4	(IE1-)B.0R 280 M4	4BZFM 100	1000	-	-	-	-
132.0	IE3-B.1R 315 M4	-	-	-	-	-	-	-	-	-
160.0	-	IE2-B.1R 315 MX4	(IE1-)B.1R 315 MX4	(IE1-)B.0R 315 S4	-	-	NFF 160	1600	-	-
160.0	IE3-B.1R 315 MX4	IE2-B.1R 315 MX4	(IE1-)B.1R 315 MX4	(IE1-)B.0R 315 S4	4BZFM 100	1000	-	-	-	-
160.0	IE3-B.1R 315 MX4	-	-	-	-	-	-	-	-	-
200.0	-	IE2-B.1R 315 MY4	(IE1-)B.1R 315 MY4	(IE1-)B.0R 315 M4	-	-	NFF 250	2500	-	-
200.0	IE3-B.1R 315 MY4	-	-	-	-	-	-	-	-	-
200.0	IE3-B.1R 315 MY4	IE2-B.1R 315 MY4	(IE1-)B.1R 315 MY4	(IE1-)B.0R 315 M4	4BZFM 160	1600	-	-	-	-
250.0	-	IE2-B.1R 315 L4	(IE1-)B.1R 315 L4	(IE1-)B.0R 315 L4	-	-	NFF 250	2500	-	-
250.0	IE3-B.1R 315 L4	IE2-B.1R 315 L4	(IE1-)B.1R 315 L4	(IE1-)B.0R 315 L4	4BZFM 160	1600	-	-	-	-
250.0	IE3-B.1R 315 L4	-	-	-	-	-	NFF 250	2500	-	-
315.0	-	IE2-B.1R 315 LX4	(IE1-)B.1R 315 LX4	(IE1-)B.0R 315 LX4	-	-	-	-	-	-
315.0	IE3-B.1R 315 LX4	-	-	-	-	-	-	-	-	-
315.0	IE3-B.1R 315 LX4	IE2-B.1R 315 LX4	(IE1-)B.1R 315 LX4	(IE1-)B.0R 315 LX4	4BZFM 160	1600	-	-	-	-
355.0	-	IE2-B.2R 355 M4	(IE1-)B.2R 355 M4	-	-	-	NFF 400	4000	-	-
355.0	IE3-B.1R 355 M4	-	-	-	-	-	-	-	-	-
355.0	IE3-B.1R 355 M4	IE2-B.2R 355 M4	(IE1-)B.2R 355 M4	-	4BZFM 250	2500	-	-	-	-
400.0	-	IE2-B.2R 355 MX4	(IE1-)B.2R 355 MX4	-	-	-	NFF 400	4000	-	-
400.0	IE3-B.2R 355 MX4	-	-	-	-	-	-	-	-	-
400.0	IE3-B.2R 355 MX4	IE2-B.2R 355 MX4	(IE1-)B.2R 355 MX4	-	4BZFM 250	2500	-	-	-	-
500.0	-	IE2-B.2R 355 L4	(IE1-)B.2R 355 L4	-	-	-	NFF 400	4000	-	-
500.0	IE3-B.2R 355 L4	-	-	-	-	-	-	-	-	-
500.0	IE3-B.2R 355 L4	IE2-B.2R 355 L4	(IE1-)B.2R 355 L4	-	4BZFM 250	2500	-	-	-	-
560.0	IE3-B.2R 400 M4	-	-	-	-	-	***)	-	-	-
630.0	IE3-B.2R 400 MX4	-	-	-	-	-	***)	-	-	-
710.0	IE3-B.2R 400 L4	-	-	-	-	-	***)	-	-	-

Corresponding basic version plus brake and brake mounting (see Extra price list)

Sizes 56–132 T plus rectifier (see Brake accessories)

*) Flange version only

1) Requires consultation regarding application

(IE1-) can be supplied with and without marking of IE classification

***) upon request

4-pole Brake motors

Built-on brake with squirrel-cage rotor; Mayr, Pintsch-Bubbenzer, Precima brake

Premium Efficiency IE3/High Efficiency IE2/Standard Efficiency IE1 according to IEC/EN 60034-30-1

P _B P _B KW	For motor IE3-	For motor IE2-	For motor (IE1-)B.1R	For motor (IE1-)B.0R	Mayr M 800/891 (IP65)	Nm	Pintsch-Bubbenzer KFB/SFB	Nm	Precima FDB	Nm
0.09	-	-	(IE1-)B.1R 56 G4	-	M2/891.	4	-	-	***	***
0.12	IE3-B.2R 63 K4	IE2-BE.2R 63 K4	(IE1-)B.1R 63 K4	(IE1-)B.0R 56 K4	M2/891.	4	-	-	***	***
0.18	IE3-B.2R 71 K4	IE2-BE.1R 63 GY4	(IE1-)B.1R 63 G4	(IE1-)B.0R 56 G4	M2/891.	4	-	-	***	***
0.25	IE3-B.2R 71 K4	IE2-B.2R 71 K4	(IE1-)B.1R 71 K4	(IE1-)B.0R 63 K4	-	-	-	-	***	***
0.25	IE3-B.2R 71 K4	IE2-B.2R 71 K4	(IE1-)B.1R 71 K4	(IE1-)B.0R 63 K4	M4/891.	4	-	-	***	***
0.37	IE3-B.1R 71 GY4	IE2-B.1R 71 GY4	(IE1-)B.1R 71 G4	(IE1-)B.0R 63 G4	-	-	-	-	***	***
0.37	-	-	(IE1-)B.1R 71 G4	(IE1-)B.0R 63 G4	M4/891.	4	-	-	***	***
0.55	-	IE2-B.2R 80 K4	(IE1-)B.1R 80 K4	(IE1-)B.0R 71 K4	-	-	-	-	***	***
0.55	IE3-B.1R 80 K4	-	(IE1-)B.1R 80 K4	(IE1-)B.0R 71 K4	M8/891.	8	-	-	***	***
0.75	-	-	(IE1-)B.1R 80 G4	(IE1-)B.0R 71 G4	-	-	-	-	***	***
0.75	IE3-B.1R 80 GX4	IE2-B.1R 80 G4	(IE1-)B.1R 80 G4	(IE1-)B.0R 71 G4	M8/891.	8	-	-	***	***
0.9	-	-	(IE1-)B.1R 80 GX4	(IE1-)B.0R 71 GX4	-	-	-	-	***	***
0.9	-	-	(IE1-)B.1R 80 GX4	(IE1-)B.0R 71 GX4	-	-	-	-	***	***
1.1	-	-	(IE1-)B.1R 90 S4	(IE1-)B.0R 80 K4	-	-	-	-	***	***
1.1	-	-	(IE1-)B.1R 90 S4	(IE1-)B.0R 80 K4	-	-	-	-	***	***
1.1	IE3-B.1R 90 S4	IE2-B.1R 90 S4	(IE1-)B.1R 90 S4	(IE1-)B.0R 80 K4	M16/891.	16	-	-	***	***
1.5	-	-	(IE1-)B.1R 90 L4	(IE1-)B.0R 80 G4	-	-	-	-	***	***
1.5	-	-	(IE1-)B.1R 90 L4	(IE1-)B.0R 80 G4	-	-	-	-	***	***
1.5	IE3-B.1R 90 LX4	IE2-B.1R 90 L4	(IE1-)B.1R 90 L4	(IE1-)B.0R 80 G4	M16/891.	16	-	-	***	***
2.2	-	-	(IE1-)B.1R 100 L4	(IE1-)B.0R 90 L4	-	-	-	-	***	***
2.2	-	-	(IE1-)B.1R 100 L4	(IE1-)B.0R 90 L4	-	-	-	-	***	***
2.2	IE3-B.1R 100 L4	IE2-B.1R 100 L4	(IE1-)B.1R 100 L4	(IE1-)B.0R 90 L4	M32/891.	32	-	-	***	***
3.0	-	-	(IE1-)B.1R 100 LX4	(IE1-)B.0R 100 S4	-	-	-	-	***	***
3.0	IE3-B.1R 100 LZ4	IE2-B.1R 100 LX4	(IE1-)B.1R 100 LX4	(IE1-)B.0R 100 S4	M32/891.	32	-	-	***	***
3.0	-	-	(IE1-)B.1R 100 LX4	(IE1-)B.0R 100 S4	M60/891.	60	-	-	***	***
4.0	-	-	(IE1-)B.1R 112 M4	(IE1-)B.0R 100 L4	-	-	-	-	***	***
4.0	-	-	(IE1-)B.1R 112 M4	(IE1-)B.0R 100 L4	-	-	-	-	***	***
4.0	IE3-B.1R 112 M4	IE2-B.1R 112 MZ4	(IE1-)B.1R 112 M4	(IE1-)B.0R 100 L4	M60/891.	60	KFB 5	50	***	***
5.5	-	-	(IE1-)B.1R 112 MX4	(IE1-)B.0R 100 LX4*)	-	-	-	-	***	***
5.5	-	-	(IE1-)B.1R 112 MX4	(IE1-)B.0R 100 LX4*)	M60/891.	60	-	-	***	***
5.5	-	-	(IE1-)B.1R 112 MX4	(IE1-)B.0R 100 LX4*)	-	-	-	-	***	***
5.5	-	-	(IE1-)B.1R 132 S4T	(IE1-)B.0R 100 LX4*)	M60/891.	60	-	-	***	***
5.5	-	-	(IE1-)B.1R 132 S4T	(IE1-)B.0R 100 LX4*)	-	-	-	-	***	***
5.5	IE3-B.1R 132 S4	IE2-B.2R 132 S4	(IE1-)B.1R 132 S4	(IE1-)B.0R 112 M4	M32/891.010.1	64	-	-	FDB 20	100
7.5	-	IE2-B.1R 132 M4	(IE1-)B.1R 132 M4	(IE1-)B.0R 132 S4	-	-	-	-	-	-
7.5	IE3-B.1R 132 M4	IE2-B.1R 132 M4	(IE1-)B.1R 132 M4	(IE1-)B.0R 132 S4	M60/891.010.1	100	KFB 10	100	FDB 20	100
11.0	-	IE2-B.2R 160 M4	(IE1-)B.1R 160 M4	(IE1-)B.0R 132 M4	-	-	-	-	-	-
11.0	IE3-B.1R 160 M4	IE2-B.2R 160 M4	(IE1-)B.1R 160 M4	(IE1-)B.0R 132 M4	M100/891.100.1	180	-	-	-	-
11.0	IE3-B.1R 160 M4	-	-	-	-	-	-	-	-	-
15.0	-	-	(IE1-)B.1R 160 L4	(IE1-)B.0R 160 S4	-	-	-	-	FDB 26	250
15.0	-	IE2-B.2R 160 L4	-	-	-	-	-	-	-	-
15.0	-	IE2-B.2R 160 L4	(IE1-)B.1R 160 L4	(IE1-)B.0R 160 S4	-	-	-	-	-	-
15.0	IE3-B.1R 160 L4C	-	-	-	-	-	-	-	-	-
15.0	IE3-B.1R 160 L4C	IE2-B.2R 160 L4	-	-	M100/891.100.1	180	KFB 30	300	FDB 26	250.00
18.5	-	IE2-B.2R 180 M4	(IE1-)B.1R 180 M4	(IE1-)B.0R 160 M4	-	-	-	-	-	-
18.5	IE3-B.1R 180 M4	IE2-B.2R 180 M4	(IE1-)B.1R 180 M4	(IE1-)B.0R 160 M4	M150/891.100.1	250	KFB 30	300	-	-
22.0	-	-	(IE1-)B.1R 180 L4	(IE1-)B.0R 180 S4	-	-	-	-	FDB 30	400
22.0	-	IE2-B.1R 180 L4	-	-	-	-	-	-	FDB 30	400
22.0	IE3-B.1R 180 L4	-	-	-	-	-	-	-	-	-
22.0	-	IE2-B.1R 180 L4	(IE1-)B.1R 180 L4	(IE1-)B.0R 180 S4	-	-	-	-	-	-
22.0	IE3-B.1R 180 L4	IE2-B.1R 180 L4	(IE1-)B.1R 180 L4	(IE1-)B.0R 180 S4	-	-	-	-	-	-
30.0	-	IE2-B.1R 200 L4	(IE1-)B.1R 200 L4	(IE1-)B.0R 180 M4	-	-	-	-	-	-
30.0	IE3-B.1R 200 L4C	-	-	-	-	-	-	-	-	-
30.0	IE3-B.1R 200 L4C	IE2-B.1R 200 L4	(IE1-)B.1R 200 L4	(IE1-)B.0R 180 M4	M250/891.100.1	450	KFB 40	400	FDB 30	400
37.0	-	-	(IE1-)B.1R 225 S4	(IE1-)B.0R 200 M4	-	-	KFB 63	630	-	-
37.0	-	IE2-B.1R 225 S4	-	-	-	-	KFB 63	630	-	-
37.0	IE3-B.1R 225 S4C	IE2-B.1R 225 S4	(IE1-)B.1R 225 S4	(IE1-)B.0R 200 M4	M250/891.100.1	450	-	-	FDB 30	400
37.0	IE3-B.1R 225 S4C	-	-	-	-	-	KFB 40	470	-	-
45.0	-	-	(IE1-)B.1R 225 M4	(IE1-)B.0R 200 L4	-	-	-	-	-	-
45.0	-	IE2-B.1R 225 M4	-	-	-	-	-	-	-	-
45.0	IE3-B.1R 225 M4	-	-	-	-	-	-	-	-	-
45.0	IE3-B.1R 225 M4	IE2-B.1R 225 M4	(IE1-)B.1R 225 M4	(IE1-)B.0R 200 L4	M500/891.100.1	500	KFB 63	630	FDB 30	400

4-pole Brake motors Built-on brake with squirrel-cage rotor; Mayr, Pintsch-Bubbenzer, Precima brake

Premium Efficiency IE3/High Efficiency IE2/Standard Efficiency IE1 according to IEC/EN 60034-30-1

P _B P _B KW	For motor IE3-	For motor IE2-	For motor (IE1-)B.1R	For motor (IE1-)B.0R	Mayr M 800/891 (IP 65)	Nm	Pintsch-Bubbenzer KFB/SFB	Nm	Precima FDB	Nm
55.0	-	IE2-B.1R 250 M4	(IE1-)B.1R 250 M4	(IE1-)B.0R 225 M4	-	-	-	-	-	-
55.0	IE3-B.1R 250 M4	IE2-B.1R 250 M4	-	-	M500/891.100.1	500	-	-	FDB 30	400
55.0	IE3-B.1R 250 M4	-	-	-	-	-	KFB 63	630	-	-
55.0	IE3-B.1R 250 M4	-	-	-	-	-	-	-	-	-
55.0	-	IE2-B.1R 250 M4	-	-	-	-	-	-	-	-
55.0	-	-	(IE1-)B.1R 250 M4	(IE1-)B.0R 225 M4	-	-	KFB 100	1000	FDB 30	400
75.0	-	IE2-B.1R 280 S4	(IE1-)B.1R 280 S4	(IE1-)B.0R 250 S4	-	-	KFB 100	1000	-	-
75.0	IE3-B.1R 280 S4	IE2-B.1R 280 S4	(IE1-)B.1R 280 S4	(IE1-)B.0R 250 S4	M500/891.100.1	500	-	-	FDB 30	400
75.0	IE3-B.1R 280 S4	-	-	-	-	-	KFB 63	630	-	-
90.0	-	-	(IE1-)B.1R 280 M4	(IE1-)B.0R 250 M4	-	-	-	-	-	-
90.0	-	IE2-B.1R 280 M4	-	-	-	-	-	-	-	-
90.0	-	IE2-B.1R 280 M4	(IE1-)B.1R 280 M4	(IE1-)B.0R 250 M4	-	-	-	-	FDB 30	400
90.0	IE3-B.1R 280 M4	-	-	-	-	-	-	-	-	-
90.0	IE3-B.1R 280 M4	IE2-B.1R 280 M4	(IE1-)B.1R 280 M4	(IE1-)B.0R 250 M4	-	-	KFB 100	1000	-	-
110.0	-	IE2-B.1R 315 S4	(IE1-)B.1R 315 S4	(IE1-)B.0R 280 S4	-	-	KFB 160	1600	-	-
110.0	IE3-B.1R 315 S4	IE2-B.1R 315 S4	(IE1-)B.1R 315 S4	(IE1-)B.0R 280 S4	-	-	-	-	-	-
110.0	IE3-B.1R 315 S4	-	-	-	M1000/891.010.1	800	KFB 100	1000	-	-
132.0	-	IE2-B.1R 315 M4	(IE1-)B.1R 315 M4	(IE1-)B.0R 280 M4	-	-	KFB 160	1600	-	-
132.0	IE3-B.1R 315 M4	IE2-B.1R 315 M4	(IE1-)B.1R 315 M4	(IE1-)B.0R 280 M4	-	-	-	-	-	-
132.0	IE3-B.1R 315 M4	-	-	-	M1000/891.010.1	1000	KFB 100	1000	-	-
160.0	-	IE2-B.1R 315 MX4	(IE1-)B.1R 315 MX4	(IE1-)B.0R 315 S4	-	-	-	-	-	-
160.0	IE3-B.1R 315 MX4	IE2-B.1R 315 MX4	(IE1-)B.1R 315 MX4	(IE1-)B.0R 315 S4	-	-	KFB 160	1600	-	-
160.0	IE3-B.1R 315 MX4	-	-	-	-	-	-	-	-	-
200.0	-	IE2-B.1R 315 MY4	(IE1-)B.1R 315 MY4	(IE1-)B.0R 315 M4	-	-	SFB 250	2500	-	-
200.0	IE3-B.1R 315 MY4	-	-	-	-	-	KFB 160	1600	-	-
200.0	IE3-B.1R 315 MY4	IE2-B.1R 315 MY4	(IE1-)B.1R 315 MY4	(IE1-)B.0R 315 M4	-	-	-	-	-	-
250.0	-	IE2-B.1R 315 L4	(IE1-)B.1R 315 L4	(IE1-)B.0R 315 L4	-	-	SFB 250	2500	-	-
250.0	IE3-B.1R 315 L4	IE2-B.1R 315 L4	(IE1-)B.1R 315 L4	(IE1-)B.0R 315 L4	-	-	-	-	-	-
250.0	IE3-B.1R 315 L4	-	-	-	-	-	KFB 160	1600	-	-
315.0	-	IE2-B.1R 315 LX4	(IE1-)B.1R 315 LX4	(IE1-)B.0R 315 LX4	-	-	SFB 250	2500	-	-
315.0	IE3-B.1R 315 LX4	-	-	-	-	-	SFB 250	2500	-	-
315.0	IE3-B.1R 315 LX4	IE2-B.1R 315 LX4	(IE1-)B.1R 315 LX4	(IE1-)B.0R 315 LX4	-	-	-	-	-	-
355.0	-	IE2-B.2R 355 M4	(IE1-)B.2R 355 M4	-	-	-	SFB 250/330	3300	-	-
355.0	IE3-B.1R 355 M4	-	-	-	-	-	SFB 250	2500	-	-
355.0	IE3-B.1R 355 M4	IE2-B.2R 355 M4	(IE1-)B.2R 355 M4	-	-	-	-	-	-	-
400.0	-	IE2-B.2R 355 MX4	(IE1-)B.2R 355 MX4	-	-	-	SFB 250/330	3300	-	-
400.0	IE3-B.2R 355 MX4	-	-	-	-	-	SFB 250	3300	-	-
400.0	IE3-B.2R 355 MX4	IE2-B.2R 355 MX4	(IE1-)B.2R 355 MX4	-	-	-	-	-	-	-
500.0	-	IE2-B.2R 355 L4	(IE1-)B.2R 355 L4	-	-	-	SFB 250/330	3300	-	-
500.0	IE3-B.2R 355 L4	-	-	-	-	-	SFB 250	3300	-	-
500.0	IE3-B.2R 355 L4	IE2-B.2R 355 L4	(IE1-)B.2R 355 L4	-	-	-	-	-	-	-
560.0	IE3-B.2R 400 M4	-	-	-	-	-	***	-	-	-
630.0	IE3-B.2R 400 MX4	-	-	-	-	-	***	-	-	-
710.0	IE3-B.2R 400 L4	-	-	-	-	-	***	-	-	-

Corresponding basic version plus brake and brake mounting (see Extra price list)

Sizes 56–132 T plus rectifier (see Brake accessories)

*) Flange version only

1) Requires consultation regarding application

(IE1-) can be supplied with and without marking of IE classification

***) upon request

6-pole Brake motors Built-on brake with squirrel-cage rotor; Stromag, Intorq brake

Premium Efficiency IE3/High Efficiency IE2/Standard Efficiency IE1 according to IEC/EN 60034-30-1

P _B P _B KW	For motor IE3-	For motor IE2-	For motor (IE1-)B.1R	For motor (IE1-)B.0R	Stromag BZFM	Nm	Stromag NFF	Nm	Intorq BFK	Nm
0.09	-	-	(IE1-)B.1R 63 K6	(IE1-)B.0R 56 K6	BZFM 0.25	3	-	-	BFK 458-06	4
0.12	IE3-B.1R 63 G6	IE2-B.2R 63 G6	(IE1-)B.1R 63 G6	(IE1-)B.0R 56 G6	BZFM 0.25	3	-	-	BFK 458-06	4
0.18	IE3-B.2R 71 KY6	IE2-B.2R 71 K6	(IE1-)B.1R 71 K6	(IE1-)B.0R 63 K6	BZFM 0.25	3	-	-	BFK 458-06	4
0.18	IE3-B.2R 71 KY6	IE2-B.2R 71 K6	(IE1-)B.1R 71 K6	(IE1-)B.0R 63 K6	BZFM 0.63	6.3	-	-	-	-
0.25	IE3-B.1R 71 GY6	IE2-BE.R 71 G6	(IE1-)B.1R 71 G6	(IE1-)B.0R 63 G6	BZFM 0.25	3	-	-	BFK 458-06	4
0.25	IE3-B.1R 71 GY6	IE2-BE.R 71 G6	(IE1-)B.1R 71 G6	(IE1-)B.0R 63 G6	BZFM 0.63	6.3	-	-	-	-
0.37	IE3-B.1R 80 K6	IE2-B.2R 80 K6	(IE1-)B.1R 80 K6	(IE1-)B.0R 71 K6	BZFM 0.63	6.3	-	-	BFK 458-06	4
0.37	-	-	(IE1-)B.1R 80 K6	(IE1-)B.0R 71 K6	BZFM 1.6	13.5	-	-	BFK 458-08	8
0.55	IE3-B.1R 80 G6	IE2-B.1R 80 GY6	(IE1-)B.1R 80 G6	(IE1-)B.0R 71 G6	BZFM 0.63	6.3	-	-	BFK 458-06	4
0.55	-	-	(IE1-)B.1R 80 G6	(IE1-)B.0R 71 G6	BZFM 1.6	13.5	-	-	BFK 458-08	8
0.75	-	-	(IE1-)B.1R 90 S6	(IE1-)B.0R 80 K6	BZFM 1.6	13.5	-	-	BFK 458-06	4
0.75	-	-	(IE1-)B.1R 90 S6	(IE1-)B.0R 80 K6	-	-	-	-	BFK 458-08	8
0.75	IE3-B.1R 90 S6	IE2-B.1R 90 S6	(IE1-)B.1R 90 S6	(IE1-)B.0R 80 K6	BZFM 2.5	27	-	-	BFK 458-10	16
1.1	-	-	(IE1-)B.1R 90 L6	(IE1-)B.0R 80 G6	BZFM 1.6	13.5	-	-	BFK 458-06	4
1.1	-	-	(IE1-)B.1R 90 L6	(IE1-)B.0R 80 G6	-	-	-	-	BFK 458-08	8
1.1	IE3-B.1R 90 L6	IE2-B.1R 90 L6	(IE1-)B.1R 90 L6	(IE1-)B.0R 80 G6	BZFM 1.6	13.5	-	-	BFK 458-10	16
1.5	-	-	(IE1-)B.1R 100 L6	(IE1-)B.0R 90 L6	BZFM 2.5	27	-	-	BFK 458-08	8
1.5	-	-	(IE1-)B.1R 100 L6	(IE1-)B.0R 90 L6	-	-	-	-	BFK 458-10	16
2.2	IE3-B.1R 100 L6	IE2-B.1R 100 LX6	(IE1-)B.1R 100 L6	(IE1-)B.0R 90 L6	BZFM 4	37	-	-	BFK 458-12	32
2.2	-	-	(IE1-)B.1R 112 M6	(IE1-)B.0R 100 L6	BZFM 4	37	-	-	BFK 458-10	16
2.2	-	-	(IE1-)B.1R 112 M6	(IE1-)B.0R 100 L6	-	-	-	-	BFK 458-12	32
2.2	IE3-B.1R 112 MZ6	IE2-B.1R 112 MV6	(IE1-)B.1R 112 M6	(IE1-)B.0R 100 L6	BZFM 6.3	65	-	-	BFK 458-14	60
3.0	-	-	(IE1-)B.1R 132 S6T	(IE1-)B.0R 100 LX6	BZFM 4	37	-	-	BFK 458-12	32
3.0	-	IE2-B.1R 112 MZ6	(IE1-)B.1R 132 S6T	(IE1-)B.0R 100 LX6	BZFM 6.3	65	-	-	BFK 458-14	60
3.0	IE3-B.1R 132 S6	-	-	-	-	-	-	-	-	-
3.0	IE3-B.1R 132 S6	IE2-B.1R 132 S6	(IE1-)B.1R 132 S6	(IE1-)B.0R 112 M6	BZFM 6.3	65	-	-	BFK 458-14	60
4.0	IE3-B.1R 132 M6	-	(IE1-)B.1R 132 M6	(IE1-)B.0R 112 MX6	BZFM 10	100	-	-	BFK 458-16	80
4.0	-	IE2-B.1R 132 M6	-	-	BZFM 10	125	-	-	BFK 458-16	80
4.0	IE3-B.1R 132 M6	-	-	-	-	-	-	-	-	-
5.5	-	IE2-B.1R 132 MX6	(IE1-)B.1R 132 MX6	(IE1-)B.0R 132 S6	-	-	-	-	BFK 458-18	150
5.5	IE3-B.1R 132 MX6	-	-	-	-	-	-	-	-	-
5.5	IE3-B.1R 132 MX6	IE2-B.1R 132 MX6	(IE1-)B.1R 132 MX6	(IE1-)B.0R 132 S6	BZFM 10	125	-	-	-	-
7.5	-	IE2-B.2R 160 M6	(IE1-)B.1R 160 M6	(IE1-)B.0R 132 M6	-	-	NFF 10	100	-	-
7.5	IE3-B.1R 160 M6	-	-	-	-	-	-	-	-	-
7.5	IE3-B.1R 160 M6	IE2-B.2R 160 M6	(IE1-)B.1R 160 M6	(IE1-)B.0R 132 M6	BZFM 16	200	-	-	BFK 458-18	150
11.0	-	IE2-B.1R 160 L6	(IE1-)B.1R 160 L6	(IE1-)B.0R 160 S6	-	-	NFF 25	250	-	-
11.0	IE3-B.1R 160 L6C	-	-	-	-	-	-	-	-	-
11.0	IE3-B.1R 160 L6C	IE2-B.1R 160 L6	(IE1-)B.1R 160 L6	(IE1-)B.0R 160 S6	BZFM 16	250	-	-	BFK 458-20	260
15.0	-	IE2-B.2R 180 L6	(IE1-)B.1R 180 L6	(IE1-)B.0R 160 M6	-	-	NFF 25	250	-	-
15.0	IE3-B.1R 180 L6C	IE2-B.2R 180 L6	(IE1-)B.1R 180 L6	(IE1-)B.0R 160 M6	BZFM 25	380	-	-	BFK 458-20	260
18.5	-	IE2-B.1R 200 L6	(IE1-)B.1R 200 L6	(IE1-)B.0R 180 S6	-	-	NFF 40	400	-	-
18.5	IE3-B.1R 200 L6	-	-	-	-	-	-	-	-	-
18.5	IE3-B.1R 200 L6	IE2-B.1R 200 L6	(IE1-)B.1R 200 L6	(IE1-)B.0R 180 S6	BZFM 25	380	-	-	BFK 458-25	400
22.0	-	IE2-B.2R 200 LX6	(IE1-)B.1R 200 LX6	(IE1-)B.0R 180 M6	-	-	-	-	-	-
22.0	-	IE2-B.2R 200 LX6	-	-	-	-	-	-	-	-
22.0	-	IE2-B.2R 200 LX6	(IE1-)B.1R 200 LX6	(IE1-)B.0R 180 M6	-	-	NFF 40	400	-	-
22.0	IE3-B.1R 200 LX6C	-	-	-	-	-	-	-	-	-
22.0	IE3-B.1R 200 LX6C	IE2-B.2R 200 LX6	(IE1-)B.1R 200 LX6	(IE1-)B.0R 180 M6	BZFM 25	380	-	-	BFK 458-25	400
30.0	-	-	(IE1-)B.1R 225 M6	(IE1-)B.0R 200 M6	-	-	-	-	-	-
30.0	-	IE2-BE2R 225 M6	-	-	BZFM 25	380	NFF 40	400	BFK 458-25	400
30.0	IE3-B.1R 225 M6	-	-	-	4BZFM 63	630	-	-	BFK 458-25	400
37.0	-	-	(IE1-)B.1R 250 M6	(IE1-)B.0R 225 M6	-	-	-	-	-	-
37.0	-	IE2-B.2R 250 M6	-	-	-	-	-	-	-	-
37.0	IE3-B.1R 250 M6	-	-	-	-	-	-	-	-	-
37.0	-	IE2-B.2R 250 M6	(IE1-)B.1R 250 M6	(IE1-)B.0R 225 M6	-	-	-	-	-	-
37.0	IE3-B.1R 250 M6	IE2-B.2R 250 M6	(IE1-)B.1R 250 M6	(IE1-)B.0R 225 M6	4BZFM 63	630	-	-	BFK 458-25	400
45.0	-	IE2-B.1R 280 S6	(IE1-)B.1R 280 S6	(IE1-)B.0R 250 S6	-	-	NFF 100	1000	-	-
45.0	IE3-B.1R 280 S6	-	-	-	-	-	-	-	-	-
45.0	IE3-B.1R 280 S6	IE2-B.1R 280 S6	(IE1-)B.1R 280 S6	(IE1-)B.0R 250 S6	4BZFM 100	1000	-	-	BFK 458-25	400
55.0	-	-	(IE1-)B.1R 280 M6	(IE1-)B.0R 250 M6	-	-	-	-	-	-
55.0	-	IE2-B.1R 280 M6	(IE1-)B.1R 280 M6	(IE1-)B.0R 250 M6	-	-	NFF 100	1000	-	-
55.0	IE3-B.1R 280 M6	IE2-B.1R 280 M6	-	-	-	-	-	-	-	-
55.0	IE3-B.1R 280 M6	IE2-B.1R 280 M6	(IE1-)B.1R 280 M6	(IE1-)B.0R 250 M6	4BZFM 100	1000	-	-	BFK 458-25	400

6-pole Brake motors Built-on brake with squirrel-cage rotor; Stromag, Intorq brake

Premium Efficiency IE3/High Efficiency IE2/Standard Efficiency IE1 according to IEC/EN 60034-30-1

P_B P_B KW	For motor IE3-	For motor IE2-	For motor (IE1-)B.1R	For motor (IE1-)B.0R	Stromag BZFM	Nm	Stromag NFF	Nm	Intorq BFK	Nm
75.0	-	IE2-B.1R 315 S6	(IE1-)B.1R 315 S6	(IE1-)B.0R 280 S6	-	-	NFF 160	1600	-	-
75.0	IE3-B.1R 315 S6	-	-	-	-	-	-	-	-	-
75.0	IE3-B.1R 315 S6	IE2-B.1R 315 S6	(IE1-)B.1R 315 S6	(IE1-)B.0R 280 S6	4BZFM 100	1000	-	-	-	-
90.0	-	IE2-B.1R 315 M6	(IE1-)B.1R 315 M6	(IE1-)B.0R 280 M6	4BZFM 100	1000	NFF 160	1600	-	-
90.0	IE3-B.1R 315 M6	-	-	-	4BZFM 160	1600	-	-	-	-
110.0	-	IE2-B.1R 315 MX6	(IE1-)B.1R 315 MX6	(IE1-)B.0R 315 S6	4BZFM 100	1000	NFF 160	1600	-	-
110.0	IE3-B.1R 315 MX6	-	-	-	4BZFM 160	1600	-	-	-	-
132.0	-	IE2-B.1R 315 MY6	(IE1-)B.1R 315 MY6	(IE1-)B.0R 315 M6	4BZFM 160	1600	NFF 250	2500	-	-
160.0	-	IE2-B.1R 315 L6	(IE1-)B.1R 315 L6	(IE1-)B.0R 315 L6	-	-	NFF 250	2500	-	-
160.0	IE3-B.1R 315 L6	-	-	-	-	-	-	-	-	-
160.0	IE3-B.41R 315 L6	IE2-B.1R 315 L6	(IE1-)B.1R 315 L6	(IE1-)B.0R 315 L6	4BZFM 160	1600	-	-	-	-
200.0	-	-	(IE1-)B.1R 315 LX6	(IE1-)B.0R 315 LX6	4BZFM 160	1600	NFF 250	2500	-	-
200.0	-	IE2-B.1R 315 LX6	(IE1-)B.1R 315 LX6	(IE1-)B.0R 315 LX6	-	-	-	-	-	-
250.0	-	IE2-B.2R 355 M6	(IE1-)B.2R 355 M6	-	-	-	NFF 400	4000	-	-
250.0	IE3-B.1R 355 M6	-	-	-	-	-	-	-	-	-
250.0	IE3-B.1R 355 M6	IE2-B.2R 355 M6	(IE1-)B.2R 355 M6	-	4BZFM 160	1600	-	-	-	-
315.0	-	-	(IE1-)B.2R 355 MX6	-	-	-	-	-	-	-
315.0	IE3-B.2R 355 MX6	-	-	-	-	-	-	-	-	-
315.0	-	IE2-B.2R 355 MX6	(IE1-)B.2R 355 MX6	-	-	-	NFF 400	4000	-	-
315.0	IE3-B.2R 355 MX6	IE2-B.2R 355 MX6	(IE1-)B.2R 355 MX6	-	4BZFM 250	2500	-	-	-	-
250.0	IE3-B.2R 355 L6	-	-	-	4BZFM 250	2500	NFF 400	4000	-	-
315.0	IE3-B.2R 355 LX6	-	-	-	4BZFM 250	2500	NFF 400	4000	-	-
355.0	IE3-B.2R 400 MY6	-	-	-	-	-	***)	-	-	-
400.0	IE3-B.2R 400 M6	-	-	-	-	-	***)	-	-	-
450.0	IE3-B.2R 400 MX6	-	-	-	-	-	***)	-	-	-
500.0	IE3-B.2R 400 L6	-	-	-	-	-	***)	-	-	-

Corresponding basic version plus brake and brake mounting (see Extra price list)

Sizes 56–132 T plus rectifier (see Brake accessories)

(IE1-) can be supplied with and without marking of IE classification

***) upon request

6-pole Brake motors

Built-on brake with squirrel-cage rotor; Mayr, Pintsch-Bubenzler, Precima brake

Premium Efficiency IE3/High Efficiency IE2/Standard Efficiency IE1 according to IEC/EN 60034-30-1

P _B P _B KW	For motor IE3-	For motor IE2-	For motor (IE1-)B.1R	For motor (IE1-)B.0R	Mayr M 800/891 (IP 65)	Nm	Pintsch-Bubenzler KFB/SFB	Nm	Precima FDB	Nm
0.09	-	-	(IE1-)B.1R 63 K6	(IE1-)B.0R 56 K6	M2/891.	4	-	-	***	***
0.12	IE3-B.1R 63 G6	IE2-B.2R 63 G6	(IE1-)B.1R 63 G6	(IE1-)B.0R 56 G6	M2/891.	4	-	-	***	***
0.18	IE3-B.2R 71 KY6	IE2-B.2R 71 K6	(IE1-)B.1R 71 K6	(IE1-)B.0R 63 K6	-	-	-	-	***	***
0.18	IE3-B.2R 71 KY6	IE2-B.2R 71 K6	(IE1-)B.1R 71 K6	(IE1-)B.0R 63 K6	M2/891.	4	-	-	***	***
0.25	IE3-B.1R 71 GY6	IE2-BE.R 71 G6	(IE1-)B.1R 71 G6	(IE1-)B.0R 63 G6	-	-	-	-	***	***
0.25	IE3-B.1R 71 GY6	IE2-BE.R 71 G6	(IE1-)B.1R 71 G6	(IE1-)B.0R 63 G6	M4/891.	4	-	-	***	***
0.37	IE3-B.1R 80 K6	IE2-B.2R 80 K6	(IE1-)B.1R 80 K6	(IE1-)B.0R 71 K6	-	-	-	-	***	***
0.37	-	-	(IE1-)B.1R 80 K6	(IE1-)B.0R 71 K6	M8/891.	8	-	-	***	***
0.55	IE3-B.1R 80 G6	IE2-B.1R 80 GY6	(IE1-)B.1R 80 G6	(IE1-)B.0R 71 G6	-	-	-	-	***	***
0.55	-	-	(IE1-)B.1R 80 G6	(IE1-)B.0R 71 G6	M8/891.	8	-	-	***	***
0.75	-	-	(IE1-)B.1R 90 S6	(IE1-)B.0R 80 K6	-	-	-	-	***	***
0.75	-	-	(IE1-)B.1R 90 S6	(IE1-)B.0R 80 K6	-	-	-	-	***	***
0.75	IE3-B.1R 90 S6	IE2-B.1R 90 S6	(IE1-)B.1R 90 S6	(IE1-)B.0R 80 K6	M16/891.	16	-	-	***	***
1.1	-	-	(IE1-)B.1R 90 L6	(IE1-)B.0R 80 G6	-	-	-	-	***	***
1.1	-	-	(IE1-)B.1R 90 L6	(IE1-)B.0R 80 G6	-	-	-	-	***	***
1.1	IE3-B.1R 90 L6	IE2-B.1R 90 L6	(IE1-)B.1R 90 L6	(IE1-)B.0R 80 G6	M16/891.	16	-	-	***	***
1.5	-	-	(IE1-)B.1R 100 L6	(IE1-)B.0R 90 L6	-	-	-	-	***	***
1.5	-	-	(IE1-)B.1R 100 L6	(IE1-)B.0R 90 L6	-	-	-	-	***	***
2.2	IE3-B.1R 100 L6	IE2-B.1R 100 LX6	(IE1-)B.1R 100 L6	(IE1-)B.0R 90 L6	M32/891.	32	-	-	***	***
2.2	-	-	(IE1-)B.1R 112 M6	(IE1-)B.0R 100 L6	-	-	-	-	***	***
2.2	-	-	(IE1-)B.1R 112 M6	(IE1-)B.0R 100 L6	-	-	-	-	***	***
2.2	IE3-B.1R 112 MZ6	IE2-B.1R 112 MV6	(IE1-)B.1R 112 M6	(IE1-)B.0R 100 L6	M60/891.	60	-	-	***	***
3.0	-	-	(IE1-)B.1R 132 S6T	(IE1-)B.0R 100 LX6	-	-	-	-	***	***
3.0	-	IE2-B.1R 112 MZ6	(IE1-)B.1R 132 S6T	(IE1-)B.0R 100 LX6	M60/891.	60	-	-	***	***
3.0	IE3-B.1R 132 S6	-	-	-	-	-	-	-	-	-
3.0	IE3-B.1R 132 S6	IE2-B.1R 132 S6	(IE1-)B.1R 132 S6	(IE1-)B.0R 112 M6	M32/891.010.1	64	-	-	FDB 17	60
4.0	IE3-B.1R 132 M6	-	(IE1-)B.1R 132 M6	(IE1-)B.0R 112 MX6	M60/891.100.1	100	-	-	FDB 20	100
4.0	-	IE2-B.1R 132 M6	-	-	M60/891.100.1	100	-	-	FDB 20	100
4.0	IE3-B.1R 132 M6	-	-	-	-	-	-	-	-	-
5.5	-	IE2-B.1R 132 MX6	(IE1-)B.1R 132 MX6	(IE1-)B.0R 132 S6	-	-	-	-	FDB 23	150
5.5	IE3-B.1R 132 MX6	-	-	-	-	-	-	-	-	-
5.5	IE3-B.1R 132 MX6	IE2-B.1R 132 MX6	(IE1-)B.1R 132 MX6	(IE1-)B.0R 132 S6	M32/891.010.1	100	KFB 10	100	-	-
7.5	-	IE2-B.2R 160 M6	(IE1-)B.1R 160 M6	(IE1-)B.0R 132 M6	-	-	KFB 10	100	-	-
7.5	IE3-B.1R 160 M6	-	-	-	M32/891.010.1	100	KFB 30	175	-	-
7.5	IE3-B.1R 160 M6	IE2-B.2R 160 M6	(IE1-)B.1R 160 M6	(IE1-)B.0R 132 M6	M100/891.100.1	180	-	-	FDB 23	150
11.0	-	IE2-B.1R 160 L6	(IE1-)B.1R 160 L6	(IE1-)B.0R 160 S6	-	-	-	-	-	-
11.0	IE3-B.1R 160 L6C	-	-	-	-	-	-	-	-	-
11.0	IE3-B.1R 160 L6C	IE2-B.1R 160 L6	(IE1-)B.1R 160 L6	(IE1-)B.0R 160 S6	M150/891.100.1	250	KFB 30	300	FDB 26	250
15.0	-	IE2-B.2R 180 L6	(IE1-)B.1R 180 L6	(IE1-)B.0R 160 M6	-	-	KFB 30	300	-	-
15.0	IE3-B.1R 180 L6C	IE2-B.2R 180 L6	(IE1-)B.1R 180 L6	(IE1-)B.0R 160 M6	M250/891.100.1	310	KFB 30	300	FDB 26	250
18.5	-	IE2-B.1R 200 L6	(IE1-)B.1R 200 L6	(IE1-)B.0R 180 S6	-	-	-	-	-	-
18.5	IE3-B.1R 200 L6	-	-	-	-	-	-	-	-	-
18.5	IE3-B.1R 200 L6	IE2-B.1R 200 L6	(IE1-)B.1R 200 L6	(IE1-)B.0R 180 S6	M250/891.100.1	450	KFB 40	400	FDB 30	400
22.0	-	(IE1-)B.1R 200 LX6	(IE1-)B.1R 200 LX6	(IE1-)B.0R 180 M6	-	-	KFB 40	400	-	-
22.0	-	IE2-B.2R 200 LX6	-	-	-	-	KFB 40/70	470	-	-
22.0	-	IE2-B.2R 200 LX6	(IE1-)B.1R 200 LX6	(IE1-)B.0R 180 M6	-	-	-	-	-	-
22.0	IE3-B.1R 200 LX6C	-	-	-	-	-	KFB 40	470	-	-
22.0	IE3-B.1R 200 LX6C	IE2-B.2R 200 LX6	(IE1-)B.1R 200 LX6	(IE1-)B.0R 180 M6	M250/891.100.1	450	-	-	FDB 30	400
30.0	-	(IE1-)B.1R 225 M6	(IE1-)B.1R 225 M6	(IE1-)B.0R 200 M6	-	-	-	-	-	-
30.0	-	IE2-BE2R 225 M6	-	-	M500/891.100.1	500	KFB 63	630	FDB 30	400
30.0	IE3-B.1R 225 M6	-	-	-	M500/891.100.1	500	KFB 63	630	FDB 30	400
37.0	-	-	(IE1-)B.1R 250 M6	(IE1-)B.0R 225 M6	-	-	-	-	-	-
37.0	-	IE2-B.2R 250 M6	-	-	-	-	-	-	-	-
37.0	IE3-B.1R 250 M6	-	-	-	-	-	KFB 63	820	-	-
37.0	-	IE2-B.2R 250 M6	(IE1-)B.1R 250 M6	(IE1-)B.0R 225 M6	-	-	-	-	-	-
37.0	IE3-B.1R 250 M6	IE2-B.2R 250 M6	(IE1-)B.1R 250 M6	(IE1-)B.0R 225 M6	M500/891.100.1	500	-	-	FDB 30	400
45.0	-	IE2-B.1R 280 S6	(IE1-)B.1R 280 S6	(IE1-)B.0R 250 S6	M500/891.100.1	500	-	-	-	-
45.0	IE3-B.1R 280 S6	-	-	-	M1000/891.010.1	500	-	-	-	-
45.0	IE3-B.1R 280 S6	IE2-B.1R 280 S6	(IE1-)B.1R 280 S6	(IE1-)B.0R 250 S6	-	-	KFB 100	1000	FDB 30	400
55.0	-	-	(IE1-)B.1R 280 M6	(IE1-)B.0R 250 M6	M500/891.100.1	560	-	-	-	-
55.0	-	IE2-B.1R 280 M6	(IE1-)B.1R 280 M6	(IE1-)B.0R 250 M6	-	-	-	-	-	-
55.0	IE3-B.1R 280 M6	IE2-B.1R 280 M6	-	-	M1000/891.010.1	560	-	-	-	-
55.0	IE3-B.1R 280 M6	IE2-B.1R 280 M6	(IE1-)B.1R 280 M6	(IE1-)B.0R 250 M6	-	-	KFB 100	1000	FDB 30	400

6-pole Brake motors Built-on brake with squirrel-cage rotor; Mayr, Pintsch-Bubenzler, Precima brake

Premium Efficiency IE3/High Efficiency IE2/Standard Efficiency IE1 according to IEC/EN 60034-30-1

P _B P _B KW	For motor IE3-	For motor IE2-	For motor (IE1-)B.1R	For motor (IE1-)B.0R	Mayr M 800/891 (IP65)	Nm	Pintsch-Bubenzler KFB/SFB	Nm	Precima FDB	Nm
75.0	-	IE2-B.1R 315 S6	(IE1-)B.1R 315 S6	(IE1-)B.0R 280 S6	-	-	-	-	-	-
75.0	IE3-B.1R 315 S6	-	-	-	M1000/891.010.1	800	-	-	-	-
75.0	IE3-B.1R 315 S6	IE2-B.1R 315 S6	(IE1-)B.1R 315 S6	(IE1-)B.0R 280 S6	-	-	KFB 160	1600	-	-
90.0	-	IE2-B.1R 315 M6	(IE1-)B.1R 315 M6	(IE1-)B.0R 280 M6	-	-	KFB 160	1600	-	-
90.0	IE3-B.1R 315 M6	-	-	-	-	-	KFB 160	1600	-	-
110.0	-	IE2-B.1R 315 MX6	(IE1-)B.1R 315 MX6	(IE1-)B.0R 315 S6	-	-	KFB 160	1600	-	-
110.0	IE3-B.1R 315 MX6	-	-	-	-	-	KFB 160	1600	-	-
132.0	-	IE2-B.1R 315 MY6	(IE1-)B.1R 315 MY6	(IE1-)B.0R 315 M6	-	-	SFB 250	2500	-	-
160.0	-	IE2-B.1R 315 L6	(IE1-)B.1R 315 L6	(IE1-)B.0R 315 L6	-	-	SFB 250	2500	-	-
160.0	IE3-B.1R 315 L6	-	-	-	-	-	KFB 160	1600	-	-
160.0	IE3-B.41R 315 L6	IE2-B.1R 315 L6	(IE1-)B.1R 315 L6	(IE1-)B.0R 315 L6	-	-	-	-	-	-
200.0	-	-	(IE1-)B.1R 315 LX6	(IE1-)B.0R 315 LX6	-	-	-	-	-	-
200.0	-	IE2-B.1R 315 LX6	(IE1-)B.1R 315 LX6	(IE1-)B.0R 315 LX6	-	-	SFB 250	2500	-	-
250.0	-	IE2-B.2R 355 M6	(IE1-)B.2R 355 M6	-	-	-	SFB 250/330	3300	-	-
250.0	IE3-B.1R 355 M6	-	-	-	-	-	KFB 160	1600	-	-
250.0	IE3-B.1R 355 M6	IE2-B.2R 355 M6	(IE1-)B.2R 355 M6	-	-	-	-	-	-	-
315.0	-	-	(IE1-)B.2R 355 MX6	-	-	-	SFB 250/330	3300	-	-
315.0	IE3-B.2R 355 MX6	-	-	-	-	-	SFB 250	2500	-	-
315.0	-	IE2-B.2R 355 MX6	(IE1-)B.2R 355 MX6	-	-	-	-	-	-	-
315.0	IE3-B.2R 355 MX6	IE2-B.2R 355 MX6	(IE1-)B.2R 355 MX6	-	-	-	-	-	-	-
250.0	IE3-B.2R 355 L6	-	-	-	-	-	SFB 250	2500	-	-
315.0	IE3-B.2R 355 LX6	-	-	-	-	-	SFB 250	2500	-	-
355.0	IE3-B.2R 400 MY6	-	-	-	-	-	***)	-	-	-
400.0	IE3-B.2R 400 M6	-	-	-	-	-	***)	-	-	-
450.0	IE3-B.2R 400 MX6	-	-	-	-	-	***)	-	-	-
500.0	IE3-B.2R 400 L6	-	-	-	-	-	***)	-	-	-

Corresponding basic version plus brake and brake mounting (see Extra price list)

Sizes 56–132 T plus rectifier (see Brake accessories)

(IE1-) can be supplied with and without marking of IE classification

***) upon request

8-pole Brake motors Built-on brake with squirrel-cage rotor; Stromag, Intorq brake

Premium Efficiency IE3/High Efficiency IE2/Standard Efficiency IE1 according to IEC/EN 60034-30-1

P _B P _B KW	For motor IE3-	For motor IE2-	For motor (IE1-)B.1R	For motor (IE1-)B.0R	Stromag BZFM	Nm	Stromag NFF	Nm	Intorq BFK	Nm
0.09	-	-	(IE1-)B.1R 71 K8	(IE1-)B.0R 63 K8	BZFM 0.25	3	-	-	-	-
0.09	-	-	(IE1-)B.1R 71 K8	(IE1-)B.0R 63 K8	BZFM 0.63	6.3	-	-	BFK 458-06	4
0.12	-	-	(IE1-)B.1R 71 G8	(IE1-)B.0R 63 G8	BZFM 0.25	3	-	-	-	-
0.12	IE3-B.1R 71 G8	IE2-B.2R 71 G8	(IE1-)B.1R 71 G8	(IE1-)B.0R 63 G8	BZFM 0.63	6.3	-	-	BFK 458-06	4
0.18	-	-	(IE1-)B.1R 80 K8	(IE1-)B.0R 71 K8	BZFM 0.63	6.3	-	-	BFK 458-06	4
0.18	IE3-B.2R 80 K8	IE2-B.2R 80 K8	(IE1-)B.1R 80 K8	(IE1-)B.0R 71 K8	BZFM 1.6	13.5	-	-	BFK 458-08	8
0.25	-	-	(IE1-)B.1R 80 G8	(IE1-)B.0R 71 G8	BZFM 0.63	6.3	-	-	BFK 458-06	4
0.25	IE3-B.1R 80 G8	IE2-B.2R 80 G8	(IE1-)B.1R 80 G8	(IE1-)B.0R 71 G8	BZFM 1.6	13.5	-	-	BFK 458-08	8
0.37	-	-	(IE1-)B.1R 90 S8	(IE1-)B.0R 80 K8	BZFM 1.6	13.5	-	-	BFK 458-06	4
0.37	IE3-B.2R 90 S8	IE2-B.2R 90 S8	(IE1-)B.1R 90 S8	(IE1-)B.0R 80 K8	BZFM 2.5	27	-	-	BFK 458-08	8
0.37	-	-	(IE1-)B.1R 90 S8	(IE1-)B.0R 80 K8	-	-	-	-	BFK 458-10	16
0.55	-	-	(IE1-)B.1R 90 L8	(IE1-)B.0R 80 G8	BZFM 1.6	13.5	-	-	BFK 458-06	4
0.55	-	-	(IE1-)B.1R 90 L8	(IE1-)B.0R 80 G8	-	-	-	-	BFK 458-08	8
0.55	IE3-B.1R 90 L8	IE2-B.2R 90 L8	(IE1-)B.1R 90 L8	(IE1-)B.0R 80 G8	BZFM 2.5	27	-	-	BFK 458-10	16
0.75	-	-	(IE1-)B.1R 100 L8	(IE1-)B.0R 90 L8	BZFM 2.5	27	-	-	BFK 458-08	8
0.75	-	-	(IE1-)B.1R 100 L8	(IE1-)B.0R 90 L8	-	-	-	-	BFK 458-10	16
0.75	IE3-B.1R 100 L8	IE2-B.1R 100 L8	(IE1-)B.1R 100 L8	(IE1-)B.0R 90 L8	BZFM 4	37	-	-	BFK 458-12	32
1.1	-	-	(IE1-)B.1R 100 LX8	(IE1-)B.0R 100 S8	BZFM 4	37	-	-	BFK 458-10	16
1.1	-	-	(IE1-)B.1R 100 LX8	(IE1-)B.0R 100 S8	-	-	-	-	BFK 458-12	32
1.1	IE3-B.1R 100 LX8	IE2-B.1R 100 LX8	(IE1-)B.1R 100 LX8	(IE1-)B.0R 100 S8	BZFM 6.3	65	-	-	BFK 458-14	60
1.5	-	-	(IE1-)B.1R 112 M8	(IE1-)B.0R 100 L8	BZFM 4	37	-	-	BFK 458-10	16
1.5	-	-	(IE1-)B.1R 112 M8	(IE1-)B.0R 100 L8	-	-	-	-	BFK 458-12	32
1.5	IE3-B.1R 112 MZ8	IE2-B.1R 112 MV8	(IE1-)B.1R 112 M8	(IE1-)B.0R 100 L8	BZFM 6.3	65	-	-	BFK 458-14	60
2.2	-	-	(IE1-)B.1R 132 S8T	(IE1-)B.0R 100 LX8	BZFM 4	37	-	-	BFK 458-12	32
2.2	-	-	(IE1-)B.1R 132 S8T	(IE1-)B.0R 100 LX8	BZFM 6.3	65	-	-	BFK 458-14	60
2.2	-	-	(IE1-)B.1R 132 S8	(IE1-)B.0R 112 M8	-	-	-	-	BFK 458-14	60
2.2	-	IE2-B.1R 132 S8	(IE1-)B.1R 132 S8	(IE1-)B.0R 112 M8	BZFM 6.3	65	-	-	-	-
2.2	IE3-B.1R 132 S8	-	-	-	BZFM 10	100	-	-	BFK 458-14	60
3.0	-	-	(IE1-)B.1R 132 M8	(IE1-)B.0R 112 MX8	-	-	-	-	BFK 458-16	80
3.0	IE3-B.1R 132 M8	-	-	-	-	-	-	-	BFK 458-16	80
3.0	IE3-B.1R 132 M8	IE2-B.1R 132 M8	(IE1-)B.1R 132 M8	(IE1-)B.0R 112 MX8	BZFM 10	100	-	-	-	-
4.0	-	-	(IE1-)B.1R 160 M8	(IE1-)B.0R 132 S8	-	-	-	-	BFK 458-18	150
4.0	-	IE2-B.1R 160 M8	(IE1-)B.1R 160 M8	-	-	-	-	-	-	-
4.0	IE3-B.1R 160 M8	-	-	-	-	-	-	-	BFK 458-16	125
4.0	IE3-B.1R 160 M8	IE2-B.1R 160 M8	(IE1-)B.1R 160 M8	(IE1-)B.0R 132 S8	BZFM 10	125	-	-	-	-
5.5	-	-	(IE1-)B.1R 160 MX8	(IE1-)B.0R 132 M8	-	-	NFF 10	100	BFK 458-18	150
5.5	IE3-B.1R 160 MX8	-	-	-	-	-	-	-	BFK 458-18	150
5.5	IE3-B.1R 160 MX8	IE2-B.2R 160 MX8	(IE1-)B.1R 160 MX8	(IE1-)B.0R 132 M8	BZFM 16	200	-	-	-	-
7.5	-	-	(IE1-)B.1R 160 L8	(IE1-)B.0R 160 S8	-	-	NFF 25	250	BFK 458-20	260
7.5	IE3-B.1R 160 L8	-	-	-	-	-	-	-	BFK 458-20	260
7.5	IE3-B.1R 160 L8	IE2-B.1R 160 L8	(IE1-)B.1R 160 L8	(IE1-)B.0R 160 S8	BZFM 16	250	-	-	-	-
11.0	-	-	(IE1-)B.1R 180 L8	(IE1-)B.0R 160 M8	-	-	NFF 25	250	BFK 458-20	260
11.0	IE3-B.1R 180 L8	-	-	-	-	-	-	-	BFK 458-20	290
11.0	IE3-B.1R 180 L8	IE2-B.2R 180 L8	(IE1-)B.1R 180 L8	(IE1-)B.0R 160 M8	BZFM 25	380	-	-	-	-
15.0	-	-	(IE1-)B.1R 200 L8	(IE1-)B.0R 180 S8	-	-	NFF 40	400	BFK 458-25	400
15.0	IE3-B.1R 200 L8	-	-	-	-	-	-	-	BFK 458-25	400
15.0	IE3-B.1R 200 L8	IE2-B.1R 200 L8	(IE1-)B.1R 200 L8	(IE1-)B.0R 180 S8	BZFM 25	380	-	-	-	-
18.5	-	-	(IE1-)B.1R 225 S8	(IE1-)B.0R 200 M8	-	-	NFF 63	630	BFK 458-25	400
18.5	IE3-B.1R 225 S8	-	-	-	-	-	-	-	BFK 458-25	490
18.5	IE3-B.1R 225 S8	IE2-B.2R 225 S8	(IE1-)B.1R 225 S8	-	BZFM 25	380	-	-	-	-
18.5	-	-	-	(IE1-)B.0R 180 M8	BZFM 25	380	-	-	-	-
22.0	-	-	(IE1-)B.1R 225 M8	(IE1-)B.0R 200 M8	BZFM 25	380	NFF 63	630	BFK 458-25	400
22.0	IE3-B.1R 225 M8	-	-	-	-	-	-	-	BFK 458-25	600
22.0	IE3-B.1R 225 M8	IE3-B.2R 225 M8	-	-	4BZFM 63	630	-	-	-	-
30.0	-	-	(IE1-)B.1R 250 M8	(IE1-)B.0R 225 M8	-	-	NFF 63	630	BFK 458-25	400
30.0	IE3-B.1R 250 M8	-	-	-	-	-	NFF 100	1000	BFK 458-25	400
30.0	IE3-B.1R 250 M8	IE2-B.1R 250 M8	(IE1-)B.1R 250 M8	(IE1-)B.0R 225 M8	4BZFM 63	800	-	-	-	-
37.0	-	-	(IE1-)B.1R 280 S8	(IE1-)B.0R 250 S8	-	-	-	-	BFK 458-25	400
37.0	IE3-B.1R 280 S8	-	(IE1-)B.1R 280 S8	(IE1-)B.0R 250 S8	-	-	NFF 100	1000	-	-
37.0	IE3-B.1R 280 S8	IE2-B.1R 280 S8	(IE1-)B.1R 280 S8	(IE1-)B.0R 250 S8	4BZFM 100	1000	-	-	-	-
45.0	-	-	(IE1-)B.1R 280 M8	(IE1-)B.0R 250 M8	-	-	-	-	-	-
45.0	IE3-B.1R 280 M8	-	(IE1-)B.1R 280 M8	(IE1-)B.0R 250 M8	-	-	NFF 100	1000	-	-
45.0	IE3-B.1R 280 M8	IE2-B.1R 280 M8	(IE1-)B.1R 280 M8	(IE1-)B.0R 250 M8	4BZFM 100	1000	-	-	-	-

8-pole Brake motors Built-on brake with squirrel-cage rotor; Stromag, Intorq brake

Premium Efficiency IE3/High Efficiency IE2/Standard Efficiency IE1 according to IEC/EN 60034-30-1

P_B P_B KW	For motor IE3-	For motor IE2-	For motor (IE1-)B.1R	For motor (IE1-)B.0R	Stromag BZFM	Nm	Stromag NFF	Nm	Intorq BfK	Nm
55.0	-	-	(IE1-)B.1R 315 S8	(IE1-)B.0R 280 S8	-	-	NFF 160	1600	-	-
55.0	IE3-B.2R 315 S8	-	-	-	-	-	NFF 100	1000	-	-
55.0	IE3-B.2R 315 S8	IE2-B.1R 315 S8	(IE1-)B.1R 315 S8	(IE1-)B.0R 280 S8	4BZFM 100	1000	-	-	-	-
75.0	-	IE2-B.1R 315 M8	(IE1-)B.1R 315 M8	(IE1-)B.0R 280 M8	4BZFM 100	1000	-	-	-	-
75.0	IE3-B.1R 315 M8	-	(IE1-)B.1R 315 M8	(IE1-)B.0R 280 M8	-	-	NFF 160	1600	-	-
75.0	IE3-B.1R 315 M8	-	-	-	4BZFM 160	1600	-	-	-	-
90.0	-	IE2-B.1R 315 MX8	(IE1-)B.1R 315 MX8	(IE1-)B.0R 315 S8	4BZFM 100	1000	-	-	-	-
90.0	IE3-B.1R 315 MX8	-	(IE1-)B.1R 315 MX8	(IE1-)B.0R 315 S8	-	-	NFF 160	1600	-	-
90.0	IE3-B.1R 315 MX8	-	-	-	4BZFM 160	1600	-	-	-	-
110.0	-	-	(IE1-)B.1R 315 MY8	(IE1-)B.0R 315 M8	-	-	NFF 250	2500	-	-
110.0	IE3-B.1R 315 MY8	IE2-B.1R 315 MY8	(IE1-)B.1R 315 MY8	(IE1-)B.0R 315 M8	4BZFM 160	1600	-	-	-	-
132.0	-	-	(IE1-)B.1R 315 L8	(IE1-)B.0R 315 L8	-	-	NFF 250	2500	-	-
132.0	IE3-B.1R 315 L8	-	-	-	-	-	NFF 160	1600	-	-
132.0	IE3-B.1R 315 L8	IE2-B.1R 315 L8	(IE1-)B.1R 315 L8	(IE1-)B.0R 315 L8	4BZFM 160	1600	-	-	-	-
160.0	-	-	(IE1-)B.1R 315 LX8	(IE1-)B.0R 315 LX8	-	-	NFF 250	2500	-	-
160.0	-	IE2-B.1R 315 LX8	(IE1-)B.1R 315 LX8	(IE1-)B.0R 315 LX8	4BZFM 160	1600	-	-	-	-
160.0	-	-	(IE1-)B.2R 355 MY8	-	-	-	NFF 250	2500	-	-
160.0	IE3-B.1R 355 MY8	IE2-B.2R 355 MY8	(IE1-)B.2R 355 MY8	-	4BZFM 160	1600	-	-	-	-
200.0	-	-	(IE1-)B.2R 355 M8	-	-	-	NFF 250	2500	-	-
200.0	IE3-B.1R 355 M8	-	-	-	-	-	NFF 160	1600	-	-
200.0	IE3-B.1R 355 M8	IE2-B.2R 355 M8	(IE1-)B.2R 355 M8	-	4BZFM 160	1600	-	-	-	-
250.0	-	-	(IE1-)B.2R 355 MX8	-	-	-	NFF 250	2500	-	-
250.0	-	IE2-B.2R 355 MX8	(IE1-)B.2R 355 MX8	-	4BZFM 160	1600	-	-	-	-
250.0	IE3-B.2R 355 MX8	-	-	-	4BZFM 250	2500	NFF 160	1600	-	-
280.0	-	-	(IE1-)B.2R 355 LY8	-	-	-	NFF 250	2500	-	-
280.0	-	IE2-B.2R 355 LY8	(IE1-)B.2R 355 LY8	-	4BZFM 160	1600	-	-	-	-
315.0	IE3-B.2R 400 MY8	-	-	-	-	-	***)	-	-	-
355.0	IE3-B.2R 400 M8	-	-	-	-	-	***)	-	-	-
400.0	IE3-B.2R 400 MX8	-	-	-	-	-	***)	-	-	-
450.0	IE3-B.2R 400 L8	-	-	-	-	-	***)	-	-	-

Corresponding basic version plus brake and brake mounting (see Extra price list)

Sizes 56–132 T plus rectifier (see Brake accessories)

(IE1-) can be supplied with and without marking of IE classification

***) upon request

8-pole Brake motors

Built-on brake with squirrel-cage rotor; Mayr, Pintsch-Bubenzler, Precima brake

Premium Efficiency IE3/High Efficiency IE2/Standard Efficiency IE1 according to IEC/EN 60034-30-1

P _B P _B KW	For motor IE3-	For motor IE2-	For motor (IE1-)B.1R	For motor (IE1-)B.0R	Mayr M 800/891 (IP65)	Nm	Pintsch-Bubenzler KFB/SFB	Nm	Precima FDB	Nm
0.09	-	-	(IE1-)B.1R 71 K8	(IE1-)B.0R 63 K8	-	-	-	-	***	***
0.09	-	-	(IE1-)B.1R 71 K8	(IE1-)B.0R 63 K8	M2/891.	4	-	-	***	***
0.12	-	-	(IE1-)B.1R 71 G8	(IE1-)B.0R 63 G8	-	-	-	-	***	***
0.12	IE3-B.1R 71 G8	IE2-B.2R 71 G8	(IE1-)B.1R 71 G8	(IE1-)B.0R 63 G8	M2/891.	4	-	-	***	***
0.18	-	-	(IE1-)B.1R 80 K8	(IE1-)B.0R 71 K8	-	-	-	-	***	***
0.18	IE3-B.2R 80 K8	IE2-B.2R 80 K8	(IE1-)B.1R 80 K8	(IE1-)B.0R 71 K8	M8/891.	8	-	-	***	***
0.25	-	-	(IE1-)B.1R 80 G8	(IE1-)B.0R 71 G8	-	-	-	-	***	***
0.25	IE3-B.1R 80 G8	IE2-B.2R 80 G8	(IE1-)B.1R 80 G8	(IE1-)B.0R 71 G8	M8/891.	8	-	-	***	***
0.37	-	-	(IE1-)B.1R 90 S8	(IE1-)B.0R 80 K8	-	-	-	-	***	***
0.37	IE3-B.2R 90 S8	IE2-B.2R 90 S8	(IE1-)B.1R 90 S8	(IE1-)B.0R 80 K8	-	-	-	-	***	***
0.37	-	-	(IE1-)B.1R 90 S8	(IE1-)B.0R 80 K8	M16/891.	16	-	-	***	***
0.55	-	-	(IE1-)B.1R 90 L8	(IE1-)B.0R 80 G8	-	-	-	-	***	***
0.55	-	-	(IE1-)B.1R 90 L8	(IE1-)B.0R 80 G8	-	-	-	-	***	***
0.55	IE3-B.1R 90 L8	IE2-B.2R 90 L8	(IE1-)B.1R 90 L8	(IE1-)B.0R 80 G8	M16/891.	16	-	-	***	***
0.75	-	-	(IE1-)B.1R 100 L8	(IE1-)B.0R 90 L8	-	-	-	-	***	***
0.75	-	-	(IE1-)B.1R 100 L8	(IE1-)B.0R 90 L8	-	-	-	-	***	***
0.75	IE3-B.1R 100 L8	IE2-B.1R 100 L8	(IE1-)B.1R 100 L8	(IE1-)B.0R 90 L8	M32/891.	32	-	-	***	***
1.1	-	-	(IE1-)B.1R 100 LX8	(IE1-)B.0R 100 S8	-	-	-	-	***	***
1.1	-	-	(IE1-)B.1R 100 LX8	(IE1-)B.0R 100 S8	-	-	-	-	***	***
1.1	IE3-B.1R 100 LX8	IE2-B.1R 100 LX8	(IE1-)B.1R 100 LX8	(IE1-)B.0R 100 S8	M60/891.	60	-	-	***	***
1.5	-	-	(IE1-)B.1R 112 M8	(IE1-)B.0R 100 L8	-	-	-	-	***	***
1.5	-	-	(IE1-)B.1R 112 M8	(IE1-)B.0R 100 L8	-	-	-	-	***	***
1.5	IE3-B.1R 112 MZ8	IE2-B.1R 112 MV8	(IE1-)B.1R 112 M8	(IE1-)B.0R 100 L8	M60/891.	60	-	-	***	***
2.2	-	-	(IE1-)B.1R 132 S8T	(IE1-)B.0R 100 LX8	-	-	-	-	***	***
2.2	-	-	(IE1-)B.1R 132 S8T	(IE1-)B.0R 100 LX8	M60/891.	60	-	-	***	***
2.2	-	-	(IE1-)B.1R 132 S8	(IE1-)B.0R 112 M8	M32/891.100.1	64	-	-	FDB 17	60
2.2	-	IE2-B.1R 132 S8	(IE1-)B.1R 132 S8	(IE1-)B.0R 112 M8	M32/891.100.1	64	-	-	-	-
2.2	IE3-B.1R 132 S8	-	-	-	M32/891.100.1	64	KFB 5	50	FDB 17	60
3.0	-	-	(IE1-)B.1R 132 M8	(IE1-)B.0R 112 MX8	-	-	-	-	FDB 20	100
3.0	IE3-B.1R 132 M8	-	-	-	M60/891.100.1	100	KFB 10	100	FDB 20	100
3.0	IE3-B.1R 132 M8	IE2-B.1R 132 M8	(IE1-)B.1R 132 M8	(IE1-)B.0R 112 MX8	M60/891.100.1	100	-	-	-	-
4.0	-	-	(IE1-)B.1R 160 M8	-	M60/891.100.1	100	KFB 10	100	FDB 23	150
4.0	-	IE2-B.1R 160 M8	(IE1-)B.1R 160 M8	-	-	-	-	-	-	-
4.0	IE3-B.1R 160 M8	-	-	-	-	-	KFB 10	100	FDB 20	100
4.0	IE3-B.1R 160 M8	IE2-B.1R 160 M8	(IE1-)B.1R 160 M8	(IE1-)B.0R 132 S8	M60/891.100.1	100	-	-	-	-
5.5	-	-	(IE1-)B.1R 160 MX8	(IE1-)B.0R 132 M8	M100/891.100.1	180	KFB 10	100	FDB 23	150
5.5	IE3-B.1R 160 MX8	-	-	-	M100/891.100.1	180	KFB 30/17.5	175	FDB 23	150
5.5	IE3-B.1R 160 MX8	IE2-B.2R 160 MX8	(IE1-)B.1R 160 MX8	(IE1-)B.0R 132 M8	M100/891.100.1	180	-	-	-	-
7.5	-	-	(IE1-)B.1R 160 L8	(IE1-)B.0R 160 S8	-	-	KFB 30	300	FDB 26	250
7.5	IE3-B.1R 160 L8	-	-	-	-	-	KFB 30/25	250	FDB 26	250
7.5	IE3-B.1R 160 L8	IE2-B.1R 160 L8	(IE1-)B.1R 160 L8	(IE1-)B.0R 160 S8	M100/891.100.1	180	-	-	-	-
11.0	-	-	(IE1-)B.1R 180 L8	(IE1-)B.0R 160 M8	M250/891.100.1	310	KFB 30	300	FDB 26	250
11.0	IE3-B.1R 180 L8	-	-	-	-	-	KFB 30	300	FDB 26	250
11.0	IE3-B.1R 180 L8	IE2-B.2R 180 L8	(IE1-)B.1R 180 L8	(IE1-)B.0R 160 M8	M250/891.100.1	450	-	-	-	-
15.0	-	-	(IE1-)B.1R 200 L8	(IE1-)B.0R 180 S8	M250/891.100.1	450	KFB 40	400	FDB 30	400
15.0	IE3-B.1R 200 L8	-	-	-	-	-	KFB 40	400	FDB 30	400
15.0	IE3-B.1R 200 L8	IE2-B.1R 200 L8	(IE1-)B.1R 200 L8	(IE1-)B.0R 180 S8	M250/891.100.1	450	-	-	-	-
18.5	-	-	(IE1-)B.1R 225 S8	-	M250/891.100.1	450	KFB 63	630	-	400
18.5	IE3-B.1R 225 S8	-	-	-	M250/891.100.1	450	KFB 40/47	470	-	400
18.5	IE3-B.1R 225 S8	IE2-B.2R 225 S8	(IE1-)B.1R 225 S8	-	M250/891.100.1	450	-	-	-	-
18.5	-	-	-	(IE1-)B.0R 180 M8	M250/891.100.1	450	-	-	-	-
22.0	-	-	(IE1-)B.1R 225 M8	(IE1-)B.0R 200 M8	M500/891.100.1	500	KFB 63	630	FDB 30	400
22.0	IE3-B.1R 225 M8	-	-	-	M500/891.100.1	500	KFB 63	630	FDB 30	400
22.0	IE3-B.1R 225 M8	IE3-B.2R 225 M8	-	-	M500/891.100.1	500	-	-	-	-
30.0	-	-	(IE1-)B.1R 250 M8	(IE1-)B.0R 225 M8	M500/891.100.1	500	KFB 63	630	FDB 30	400
30.0	IE3-B.1R 250 M8	-	-	-	M500/891.100.1	500	KFB 63	630	FDB 30	400
30.0	IE3-B.1R 250 M8	IE2-B.1R 250 M8	(IE1-)B.1R 250 M8	(IE1-)B.0R 225 M8	M500/891.100.1	500	-	-	-	-
37.0	-	-	(IE1-)B.1R 280 S8	(IE1-)B.0R 250 S8	M500/891.100.1	500	KFB 100	1000	FDB 30	400
37.0	IE3-B.1R 280 S8	-	(IE1-)B.1R 280 S8	(IE1-)B.0R 250 S8	M500/891.100.1	500	KFB 100	1000	-	-
37.0	IE3-B.1R 280 S8	IE2-B.1R 280 S8	(IE1-)B.1R 280 S8	(IE1-)B.0R 250 S8	M500/891.100.1	500	-	-	-	-
45.0	-	-	(IE1-)B.1R 280 M8	(IE1-)B.0R 250 M8	-	-	-	-	-	-
45.0	IE3-B.1R 280 M8	-	(IE1-)B.1R 280 M8	(IE1-)B.0R 250 M8	M500/891.100.1	700	KFB 100	1000	-	-
45.0	IE3-B.1R 280 M8	IE2-B.1R 280 M8	(IE1-)B.1R 280 M8	(IE1-)B.0R 250 M8	M500/891.100.1	700	-	-	-	-

8-pole Brake motors Built-on brake with squirrel-cage rotor; Mayr, Pintsch-Bubbenzer, Precima brake

Premium Efficiency IE3/High Efficiency IE2/Standard Efficiency IE1 according to IEC/EN 60034-30-1

P _B P _B KW	For motor IE3-	For motor IE2-	For motor (IE1-)B.1R	For motor (IE1-)B.0R	Mayr M 800/891 (IP65)	Nm	Pintsch-Bubbenzer KFB/SFB	Nm	Precima FDB	Nm
55.0	-	-	(IE1-)B.1R 315 S8	(IE1-)B.0R 280 S8	-	-	KFB 160	1600	-	-
55.0	IE3-B.2R 315 S8	-	-	-	-	-	KFB 100	1000	-	-
55.0	IE3-B.2R 315 S8	IE2-B.1R 315 S8	(IE1-)B.1R 315 S8	(IE1-)B.0R 280 S8	-	-	-	-	-	-
75.0	-	IE2-B.1R 315 M8	(IE1-)B.1R 315 M8	(IE1-)B.0R 280 M8	-	-	-	-	-	-
75.0	IE3-B.1R 315 M8	-	(IE1-)B.1R 315 M8	(IE1-)B.0R 280 M8	-	-	KFB 160	1600	-	-
75.0	IE3-B.1R 315 M8	-	-	-	-	-	-	-	-	-
90.0	-	IE2-B.1R 315 MX8	(IE1-)B.1R 315 MX8	(IE1-)B.0R 315 S8	-	-	-	-	-	-
90.0	IE3-B.1R 315 MX8	-	(IE1-)B.1R 315 MX8	(IE1-)B.0R 315 S8	-	-	KFB 160	1600	-	-
90.0	IE3-B.1R 315 MX8	-	-	-	-	-	-	-	-	-
110.0	-	-	(IE1-)B.1R 315 MY8	(IE1-)B.0R 315 M8	-	-	SFB 250	2500	-	-
110.0	IE3-B.1R 315 MY8	IE2-B.1R 315 MY8	(IE1-)B.1R 315 MY8	(IE1-)B.0R 315 M8	-	-	-	-	-	-
132.0	-	-	(IE1-)B.1R 315 L8	(IE1-)B.0R 315 L8	-	-	SFB 250	2500	-	-
132.0	IE3-B.1R 315 L8	-	-	-	-	-	KFB 160	1600	-	-
132.0	IE3-B.1R 315 L8	IE2-B.1R 315 L8	(IE1-)B.1R 315 L8	(IE1-)B.0R 315 L8	-	-	-	-	-	-
160.0	-	-	(IE1-)B.1R 315 LX8	(IE1-)B.0R 315 LX8	-	-	SFB 250	2500	-	-
160.0	-	IE2-B.1R 315 LX8	(IE1-)B.1R 315 LX8	(IE1-)B.0R 315 LX8	-	-	-	-	-	-
160.0	-	-	(IE1-)B.2R 355 MY8	-	-	-	SFB 250	2500	-	-
160.0	IE3-B.1R 355 MY8	IE2-B.2R 355 MY8	(IE1-)B.2R 355 MY8	-	-	-	-	-	-	-
200.0	-	-	(IE1-)B.2R 355 M8	-	-	-	SFB 250	2500	-	-
200.0	IE3-B.1R 355 M8	-	-	-	-	-	SFB 250	2500	-	-
200.0	IE3-B.1R 355 M8	IE2-B.2R 355 M8	(IE1-)B.2R 355 M8	-	-	-	-	-	-	-
250.0	-	-	(IE1-)B.2R 355 MX8	-	-	-	SFB 250	2500	-	-
250.0	-	IE2-B.2R 355 MX8	(IE1-)B.2R 355 MX8	-	-	-	-	-	-	-
250.0	IE3-B.2R 355 MX8	-	-	-	-	-	SFB 250	2500	-	-
280.0	-	-	(IE1-)B.2R 355 LY8	-	-	-	SFB 250	2500	-	-
280.0	-	IE2-B.2R 355 LY8	(IE1-)B.2R 355 LY8	-	-	-	-	-	-	-
315.0	IE3-B.2R 400 MY8	-	-	-	-	-	***	-	-	-
355.0	IE3-B.2R 400 M8	-	-	-	-	-	***	-	-	-
400.0	IE3-B.2R 400 MX8	-	-	-	-	-	***	-	-	-
450.0	IE3-B.2R 400 L8	-	-	-	-	-	***	-	-	-

Corresponding basic version plus brake and brake mounting (see Extra price list)

Sizes 56–132 T plus rectifier (see Brake accessories)

(IE1-) can be supplied with and without marking of IE classification

***) upon request

Brake accessories

Accessories for Stromag brakes

Brake Stromag	M _H Nm	Manual release	Microswitch	Heating tape*	Rectifier
BZFM 0.25	3	X	X	-	X
BZFM 0.63	6.3	X	X	-	X
BZFM 1.60	13.5	X	X	-	X
BZFM 2.5	27	X	X	-	X
BZFM 4	37	X	X	-	X
BZFM 6.3	65	X	X	-	X
BZFM 10	100	X	X	-	X
BZFM 16	200	X	X	-	X
BZFM 25	380	X	X	-	X
*only applicable for 4BZFM					
4BZFM 16	160	-	X	X	X
4BZFM 25	250	-	X	X	X
4BZFM 40	400	-	X	X	X
4BZFM 63	630	-	X	X	X
4BZFM 100	1000	-	X	X	X
4BZFM 160	1600	-	X	X	X
4BZFM 250	2500	-	X	X	X

Accessories for Stromag brakes

Brake Stromag	M _H Nm	Manual release	Microswitch	Heating tape	Rectifier
NFF 10	100	X	X	X	X
NFF 16	160	X	X	X	X
NFF 25	250	X	X	X	X
NFF 40	400	X	X	X	X
NFF 63	630	X	X	X	X
NFF 100	1000	X	X	X	X
NFF 160	1600	X	X	***)	X
NFF 250	2500	-	X	***)	X
NFF 400	4000	-	X	***)	X

Accessories for Intorq brakes

Brake Intorq	M _H Nm	Manual release	Microswitch	Heating tape	Rectifier
BFK458-06	4	X	-	X	X
BFK458-08	8	X	-	X	X
BFK458-10	16	X	-	X	X
BFK458-12	32	X	X	X	X
BFK458-14	60	X	X	X	X
BFK458-16	80	X	X	X	X
BFK458-18	150	X	X	X	X
BFK458-20	260	X	X	X	X
BFK458-25	400	X	X	X	X

Accessories for Mayr brakes

Brake Mayr	M _H Nm	Manual release	Microswitch	Heating tape	Rectifier
3/800.412.3	3	x	***)	***)	x
4/800.412.3	6	x	***)	***)	x
6/800.412.3	26	x	***)	***)	x
7/800.412.3	50	x	***)	***)	x
M32/891.100.1	64	x	x	-	x
M60/891.100.1	100	x	x	x	x
M100/891.100.1	180	x	x	x	x
M150/891.100.1	250	x	x	x	x
M250/891.100.1	310	x	x	-	x
M500/891.100.1	500	x	x	-	x
M1000/891.100.1	1000	x	x	-	x

*) Emergency manual release only

Accessories for Pintsch-Bubbenzer brakes

Brake Pintsch-Bubbenzer	M _H Nm	Manual release	Microswitch	Heating tape	Rectifier
KFB 5	50	x	x	x	x
KFB 10	100	x	x	x	x
KFB 16	160	x	x	x	x
KFB 30	300	x	x	x	x
KFB 40	400	x	x	x	x
KFB 63	630	x	x	x	x
KFB 100	1000	x	x	x	x
KFB 160	1600	x	x	x	x
SFB 250	2500	-	x	x	x
SFB 250/330	3300	-	x	x	x

Accessories for Precima brakes

Brake FDB	M _H Nm	Manual release	Microswitch	Heating tape	Rectifier
15	40	x	***)	***)	x
17	60	x	***)	***)	x
20	100	x	***)	***)	x
23	150	x	***)	***)	x
26	250	x	***)	***)	x
30	400	x	***)	***)	x
40	1000	x	***)	***)	x

***) upon request

Brake motors with squirrel-cage rotor, three-phase Temporiti brake

Standard Efficiency IE1 according to IEC/EN 60034-30-1

Construction type IM B3, duty type S1, degree of protection IP 55, thermal class 155

P _B kW	Type	Type	Brake	M _H Nm
Synchronous speed 3000 rpm – 2-pole version				
0.18	(IE1-)B21R 63 K2	(IE1-)B20R 56 K2	AC 1	4
0.25	(IE1-)B21R 63 G2	(IE1-)B20R 56 G2	AC 1	4
0.37	(IE1-)B21R 71 K2	(IE1-)B20R 63 K2	AC 1	4
0.55	(IE1-)B21R 71 G2	(IE1-)B20R 63 G2	AC 1	4
0.75	(IE1-)B21R 80 K2	(IE1-)B20R 71 K2	AC 1	4
1.1	(IE1-)B21R 80 G2	(IE1-)B20R 71 G2	AC 1	4
1.5	(IE1-)B21R 90 S2	(IE1-)B20R 80 K2	AC 2	8
2.2	(IE1-)B21R 90 L2	(IE1-)B20R 80 G2	AC 2	8
3.0	(IE1-)B21R 100 L2	(IE1-)B20R 90 L2	AC 4	16
4.0	(IE1-)B21R 112 M2	(IE1-)B20R 100 S2	AC 5	35
4.0	(IE1-)B21R 112 M2	(IE1-)B20R 100 S2	AC 6	60
5.5	(IE1-)B21R 132 S2T	(IE1-)B20R 100 L2	AC 5	35
5.5	(IE1-)B21R 132 S2T	(IE1-)B20R 100 L2	AC 6	60
7.5	(IE1-)B21R 132 SX2T	(IE1-)B20R 100 LV2*)	AC 5	35
7.5	(IE1-)B21R 132 SX2T	(IE1-)B20R 100 LV2*)	AC 6	60
Synchronous speed 1500 rpm – 4-pole version				
0.12	(IE1-)B21R 63 K4	(IE1-)B20R 56 K4	AC 1	4
0.18	(IE1-)B21R 63 G4	(IE1-)B20R 56 G4	AC 1	4
0.25	(IE1-)B21R 71 K4	(IE1-)B20R 63 K4	AC 1	4
0.37	(IE1-)B21R 71 G4	(IE1-)B20R 63 G4	AC 1	4
0.55	(IE1-)B21R 80 K4	(IE1-)B20R 71 K4	AC 1	4
0.75	(IE1-)B21R 80 G4	(IE1-)B20R 71 G4	AC 1	4
1.1	(IE1-)B21R 90 S4	(IE1-)B20R 80 K4	AC 2	8
1.5	(IE1-)B21R 90 L4	(IE1-)B20R 80 G4	AC 2	8
2.2	(IE1-)B21R 100 L4	(IE1-)B20R 90 L4	AC 4	16
3.0	(IE1-)B21R 100 LX4	(IE1-)B20R 100 S4	AC 5	35
3.0	(IE1-)B21R 100 LX4	(IE1-)B20R 100 S4	AC 6	60
4.0	(IE1-)B21R 112 M4	(IE1-)B20R 100 L4	AC 5	35
4.0	(IE1-)B21R 112 M4	(IE1-)B20R 100 L4	AC 6	60
5.5	(IE1-)B21R 132 S4T	(IE1-)B20R 100 LX4*)	AC 5	35
5.5	(IE1-)B21R 132 S4T	(IE1-)B20R 100 LX4*)	AC 6	60

Corresponding basic version plus brake

*) No manual release possible

(IE1-) can be supplied with and without marking of IE classification

Brake motors with squirrel-cage rotor, three-phase Temporit brake

Standard Efficiency IE1 according to IEC/EN 60034-30-1

Construction type IM B3, duty type S1, degree of protection IP 55, thermal class 155

P _B kW	Type	Type	Brake	M _H Nm
Synchronous speed 1000 rpm – 6-pole version				
0.09	(IE1-)B21R 63 K6	(IE1-)B20R 56 K6	AC 1	4
0.12	(IE1-)B21R 63 G6	(IE1-)B20R 56 G6	AC 1	4
0.18	(IE1-)B21R 71 K6	(IE1-)B20R 63 K6	AC 1	4
0.25	(IE1-)B21R 71 G6	(IE1-)B20R 63 G6	AC 1	4
0.37	(IE1-)B21R 80 K6	(IE1-)B20R 71 K6	AC 1	4
0.55	(IE1-)B21R 80 G6	(IE1-)B20R 71 G6	AC 1	4
0.75	(IE1-)B21R 90 S6	(IE1-)B20R 80 K6	AC 2	8
1.1	(IE1-)B21R 90 L6	(IE1-)B20R 80 G6	AC 2	8
1.5	(IE1-)B21R 100 L6	(IE1-)B20R 90 L6	AC 4	16
2.2	(IE1-)B21R 112 M6	(IE1-)B20R 100 L6	AC 5	35
2.2	(IE1-)B21R 112 M6	(IE1-)B20R 100 L6	AC 6	60
3.0	(IE1-)B21R 132 S6T	(IE1-)B20R 100 LX6	AC 5	35
3.0	(IE1-)B21R 132 S6T	(IE1-)B20R 100 LX6	AC 6	60
Synchronous speed 750 rpm – 8-pole version				
0.09	(IE1-)B21R 71 K8	(IE1-)B20R 63 K8	AC 1	4
0.12	(IE1-)B21R 71 G8	(IE1-)B20R 63 G8	AC 1	4
0.18	(IE1-)B21R 80 K8	(IE1-)B20R 71 K8	AC 1	4
0.25	(IE1-)B21R 80 G8	(IE1-)B20R 71 G8	AC 1	4
0.37	(IE1-)B21R 90 S8	(IE1-)B20R 80 K8	AC 2	8
0.55	(IE1-)B21R 90 L8	(IE1-)B20R 80 G8	AC 2	8
0.75	(IE1-)B21R 100 L8	(IE1-)B20R 90 L8	AC 4	16
1.1	(IE1-)B21R 100 LX8	(IE1-)B20R 100 S8	AC 5	35
1.1	(IE1-)B21R 100 LX8	(IE1-)B20R 100 S8	AC 6	60
1.5	(IE1-)B21R 112 M8	(IE1-)B20R 100 L8	AC 5	35
1.5	(IE1-)B21R 112 M8	(IE1-)B20R 100 L8	AC 6	60
2.2	(IE1-)B21R 132 S8T	(IE1-)B20R 100 LX8	AC 5	35
2.2	(IE1-)B21R 132 S8T	(IE1-)B20R 100 LX8	AC 6	60

Corresponding basic version plus brake

¹⁾ No manual release possible

(IE1-) can be supplied with and without marking of IE classification

**Explosion-protected brake motors with squirrel-cage rotor, Mayr brake
CE 0637 Ex tD A 21 IP 65 T 125 °C**

Standard Efficiency IE1 according to IEC/EN 60034-30

Brake motors for use in Zone 21 according to EN 61241-1

Thermal class 155, degree of protection IP 65, max. surface temperature 125 °C

Construction type IM B3, duty type S4 40 %, 1 set PTC thermistors (TPM140)

Version for rated voltage range A according to IEC/EN 60034-1, 50 Hz

P _B kW	Type	Type	Brake	M _H Nm
Synchronous speed 3000 rpm – 2-pole version				
0.18	(IE1-)BPER 63 K2	(IE1-)BPR 56 K2	M2	2
0.25	(IE1-)BPER 63 G2	(IE1-)BPR 56 G2	M2	2
0.37	(IE1-)BPER 71 K2	(IE1-)BPR 63 K2	M2	2
0.37	(IE1-)BPER 71 K2	(IE1-)BPR 63 K2	M4	4
0.55	(IE1-)BPER 71 G2	(IE1-)BPR 63 G2	M2	2
0.55	(IE1-)BPER 71 G2	(IE1-)BPR 63 G2	M4	4
0.75	(IE1-)BPER 80 K2	(IE1-)BPR 71 K2	M4	4
0.75	(IE1-)BPER 80 K2	(IE1-)BPR 71 K2	M8	8
1.1	(IE1-)BPER 80 G2	(IE1-)BPR 71 G2	M4	4
1.1	(IE1-)BPER 80 G2	(IE1-)BPR 71 G2	M8	8
1.5	(IE1-)BPER 90 S2	(IE1-)BPR 80 K2	M8	8
1.5	(IE1-)BPER 90 S2	(IE1-)BPR 80 K2	M16	16
2.2	(IE1-)BPER 90 L2	(IE1-)BPR 80 G2	M8	8
2.2	(IE1-)BPER 90 L2	(IE1-)BPR 80 G2	M16	16
3.0	(IE1-)BPER 100 L2	(IE1-)BPR 90 L2	M16	16
3.0	(IE1-)BPER 100 L2	(IE1-)BPR 90 L2	M32	32
4.0	(IE1-)BPER 112 M2	(IE1-)BPR 100 S2	M32	32
4.0	(IE1-)BPER 112 M2	(IE1-)BPR 100 S2	M60	60
5.5	(IE1-)BPER 132 S2T	-	M32	32
5.5	(IE1-)BPER 132 S2T	-	M60	60
7.5	(IE1-)BPER 132 SX2T	-	M32	32
7.5	(IE1-)BPER 132 SX2T	-	M60	60
Synchronous speed 1500 rpm – 4-pole version				
0.12	(IE1-)BPER 63 K4	(IE1-)BPR 56 K4	M2	2
0.18	(IE1-)BPER 63 G4	(IE1-)BPR 56 G4	M2	2
0.25	(IE1-)BPER 71 K4	(IE1-)BPR 63 K4	M2	2
0.25	(IE1-)BPER 71 K4	(IE1-)BPR 63 K4	M4	4
0.37	(IE1-)BPER 71 G4	(IE1-)BPR 63 G4	M2	2
0.37	(IE1-)BPER 71 G4	(IE1-)BPR 63 G4	M4	4
0.55	(IE1-)BPER 80 K4	(IE1-)BPR 71 K4	M4	4
0.55	(IE1-)BPER 80 K4	(IE1-)BPR 71 K4	M8	8
0.75	(IE1-)BPER 80 G4	(IE1-)BPR 71 G4	M4	4
0.75	(IE1-)BPER 80 G4	(IE1-)BPR 71 G4	M8	8
1.1	(IE1-)BPER 90 S4	(IE1-)BPR 80 K4	M8	8
1.1	(IE1-)BPER 90 S4	(IE1-)BPR 80 K4	M16	16
1.5	(IE1-)BPER 90 L4	(IE1-)BPR 80 G4	M8	8
1.5	(IE1-)BPER 90 L4	(IE1-)BPR 80 G4	M16	16
2.2	(IE1-)BPER 100 L4	(IE1-)BPR 90 L4	M16	16
2.2	(IE1-)BPER 100 L4	(IE1-)BPR 90 L4	M32	32
3.0	(IE1-)BPER 100 LX4	(IE1-)BPR 100 S4	M32	32
3.0	(IE1-)BPER 100 LX4	(IE1-)BPR 100 S4	M60	60
4.0	(IE1-)BPER 112 M4	(IE1-)BPR 100 L4	M32	32
4.0	(IE1-)BPER 112 M4	(IE1-)BPR 100 L4	M60	60
5.5	(IE1-)BPER 132 S4T	-	M32	32
5.5	(IE1-)BPER 132 S4T	-	M60	60

Corresponding basic version plus brake

(IE1-) can be supplied with and without marking of IE classification

Explosion-protected brake motors with squirrel-cage rotor, Mayr brake CE 0637 Ex tD A 21 IP 65 T 125 °C

Standard Efficiency IE1 according to IEC/EN 60034-30

Brake motors for use in Zone 21 according to EN 61241-1

thermal class 155, degree of protection IP 65, max. surface temperature 125 °C

Construction type IM B3, duty type S4 40 %, 1 set PTC thermistors (TPM140)

Version for rated voltage range A according to IEC/EN 60034-1, 50 Hz

P _B kW	Type	Type	Brake	M _H Nm
Synchronous speed 1000 rpm – 6-pole version				
0.09	(IE1-)BPER 63 K6	(IE1-)BPR 56 K6	M2	2
0.12	(IE1-)BPER 63 G6	(IE1-)BPR 56 G6	M2	2
0.18	(IE1-)BPER 71 K6	(IE1-)BPR 63 K6	M2	2
0.18	(IE1-)BPER 71 K6	(IE1-)BPR 63 K6	M4	4
0.25	(IE1-)BPER 71 G6	(IE1-)BPR 63 G6	M2	2
0.25	(IE1-)BPER 71 G6	(IE1-)BPR 63 G6	M4	4
0.37	(IE1-)BPER 80 K6	(IE1-)BPR 71 K6	M4	4
0.37	(IE1-)BPER 80 K6	(IE1-)BPR 71 K6	M8	8
0.55	(IE1-)BPER 80 G6	(IE1-)BPR 71 G6	M4	4
0.55	(IE1-)BPER 80 G6	(IE1-)BPR 71 G6	M8	8
0.75	(IE1-)BPER 90 S6	(IE1-)BPR 80 K6	M8	8
0.75	(IE1-)BPER 90 S6	(IE1-)BPR 80 K6	M16	16
1.1	(IE1-)BPER 90 L6	(IE1-)BPR 80 G6	M8	8
1.1	(IE1-)BPER 90 L6	(IE1-)BPR 80 G6	M16	16
1.5	(IE1-)BPER 100 L6	(IE1-)BPR 90 L6	M16	16
1.5	(IE1-)BPER 100 L6	(IE1-)BPR 90 L6	M32	32
2.2	(IE1-)BPER 112 M6	(IE1-)BPR 100 L6	M32	32
2.2	(IE1-)BPER 112 M6	(IE1-)BPR 100 L6	M60	60
3.0	(IE1-)BPER 132 S6T	-	M32	32
3.0	(IE1-)BPER 132 S6T	-	M60	60
Synchronous speed 750 rpm – 8-pole version				
0.09	(IE1-)BPER 71 K8	BPR 63 K8	M2	2
0.09	(IE1-)BPER 71 K8	BPR 63 K8	M4	4
0.12	(IE1-)BPER 71 G8	BPR 63 G8	M2	2
0.12	(IE1-)BPER 71 G8	BPR 63 G8	M4	4
0.18	(IE1-)BPER 80 K8	BPR 71 K8	M4	4
0.18	(IE1-)BPER 80 K8	BPR 71 K8	M8	8
0.25	(IE1-)BPER 80 G8	BPR 71 G8	M4	4
0.25	(IE1-)BPER 80 G8	BPR 71 G8	M8	8
0.37	(IE1-)BPER 90 S8	BPR 80 K8	M8	8
0.37	(IE1-)BPER 90 S8	BPR 80 K8	M16	16
0.55	(IE1-)BPER 90 L8	BPR 80 G8	M8	8
0.55	(IE1-)BPER 90 L8	BPR 80 G8	M16	16
0.75	(IE1-)BPER 100 L8	BPR 90 L8	M16	16
0.75	(IE1-)BPER 100 L8	BPR 90 L8	M32	32
1.1	(IE1-)BPER 100 LX8	BPR 100 S8	M32	32
1.1	(IE1-)BPER 100 LX8	BPR 100 S8	M60	60
1.5	(IE1-)BPER 112 M8	BPR 100 L8	M32	32
1.5	(IE1-)BPER 112 M8	BPR 100 L8	M60	60
2.2	(IE1-)BPER 132 S8T	BPR 100 LX8	M32	32
2.2	(IE1-)BPER 132 S8T	BPR 100 LX8	M60	60

Corresponding basic version plus brake

(IE1-) can be supplied with and without marking of IE classification

Brake motors with built-on compact brake Intorq BFK 457

Standard Efficiency IE1 according to IEC/EN 60034-30

Construction type IM B3, degree of protection IP 54, thermal class 155

P_B kW	Type	Type	M_H Nm
Synchronous speed 3000 rpm – 2-pole version			
0.18	B21R 63 K2 BLEN	B20R 56 K2 BLEN	2
0.25	B21R 63 G2 BLEN	B20R 56 G2 BLEN	2
0.37	B21R 71 K2 BLEN	B20R 63 K2 BLEN	2
0.55	B21R 71 G2 BLEN	B20R 63 G2 BLEN	2
0.75	B21R 80 K2 BLEN	B20R 71 K2 BLEN	4
1.1	B21R 80 G2 BLEN	B20R 71 G2 BLEN	4
1.5	B21R 90 S2 BLEN	B20R 80 K2 BLEN	8
2.2	B21R 90 L2 BLEN	B20R 80 G2 BLEN	8
3.0	B21R 100 L2 BLEN	B20R 90 L2 BLEN	16
4.0	B21R 112 M2 BLEN	B20R 100 S2 BLEN	16
5.5	B21R 112 MX2 BLEN	B20R 100 L2 BLEN	16
Synchronous speed 1500 rpm – 4-pole version			
0.12	B21R 63 K4 BLEN	B20R 56 K4 BLEN	2
0.18	B21R 63 G4 BLEN	B20R 56 G4 BLEN	2
0.25	B21R 71 K4 BLEN	B20R 63 K4 BLEN	2
0.37	B21R 71 G4 BLEN	B20R 63 G4 BLEN	2
0.55	B21R 80 K4 BLEN	B20R 71 K4 BLEN	4
0.75	B21R 80 G4 BLEN	B20R 71 G4 BLEN	4
1.1	B21R 90 S4 BLEN	B20R 80 K4 BLEN	8
1.5	B21R 90 L4 BLEN	B20R 80 G4 BLEN	8
2.2	B21R 100 L4 BLEN	B20R 90 L4 BLEN	16
3.0	B21R 100 LX4 BLEN	B20R 100 S4 BLEN	16
4.0	B21R 112 M4 BLEN	B20R 100 L4 BLEN	16
Synchronous speed 1000 rpm – 6-pole version			
0.12	B21R 63 G6 BLEN	B20R 56 G6 BLEN	2
0.18	B21R 71 K6 BLEN	B20R 63 K6 BLEN	2
0.25	B21R 71 G6 BLEN	B20R 63 G6 BLEN	2
0.37	B21R 80 K6 BLEN	B20R 71 K6 BLEN	4
0.55	B21R 80 G6 BLEN	B20R 71 G6 BLEN	4
0.75	B21R 90 S6 BLEN	B20R 80 K6 BLEN	8
1.1	B21R 90 L6 BLEN	B20R 80 G6 BLEN	8
1.5	B21R 100 L6 BLEN	B20R 90 L6 BLEN	16
2.2	B21R 112 M6 BLEN	B20R 100 L6 BLEN	16
Synchronous speed 750 rpm – 8-pole version			
0.12	B21R 71 G8 BLEN	B20R 63 G8 BLEN	2
0.18	B21R 80 K8 BLEN	B20R 71 K8 BLEN	4
0.25	B21R 80 G8 BLEN	B20R 71 G8 BLEN	4
0.37	B21R 90 S8 BLEN	B20R 80 K8 BLEN	8
0.55	B21R 90 L8 BLEN	B20R 80 G8 BLEN	8
0.75	B21R 100 L8 BLEN	B20R 90 L8 BLEN	16
1.1	B21R 100 LX8 BLEN	B20R 100 S8 BLEN	16
1.5	B21R 112 M8 BLEN	B20R 100 L8 BLEN	16

(IE1-) can be supplied with and without marking of IE classification

Explosion-protected brake motors with squirrel-cage rotor, Mayr brake CE 0637 Ex II 3D Ex tc IIIB T 125 °C Dc

Standard Efficiency IE1 according to IEC/EN 60034-30-1

Brake motors for use in Zone 22 according to EN 60079-31

thermal class 155, degree of protection IP 55, max. surface temperature 125 °C

Construction type IM B3, duty type S1, 1 set PTC thermistors (TPM130)

Version for rated voltage range A according to IEC/EN 60034-1, 50 Hz

P _B kW	Type	Type	Brake	M _H Nm
Synchronous speed 3000 rpm – 2-pole version				
5.5	(IE1-)B21R 132 S2 ¹⁾	(IE1-)B20R 112 MY2 ¹⁾	M32/891.010.1	40
7.5	(IE1-)B21R 132 SX2 ¹⁾	(IE1-)B20R 112 M2 ¹⁾	M32/891.010.1	64
11.0	(IE1-)B21R 160 M2 ¹⁾	(IE1-)B20R 132 M2 ¹⁾	M32/891.010.1	64
15.0	(IE1-)B21R 160 MX2 ¹⁾	(IE1-)B20R 160 S2 ¹⁾	M60/891.010.1	100
18.5	(IE1-)B21R 160 L2 ¹⁾	(IE1-)B20R 160 M2 ¹⁾	M100/891.010.1	180
22.0	(IE1-)B21R 180 M2 ¹⁾	(IE1-)B20R 180 S2 ¹⁾	M150/891.010.1	150
30.0	(IE1-)B21R 200 L2 ¹⁾	(IE1-)B20R 180 M2 ¹⁾	M150/891.010.1	250
37.0	(IE1-)B21R 200 LX2 ¹⁾	(IE1-)B20R 200 M2 ¹⁾	M250/891.010.1	310
45.0	(IE1-)B21R 225 M2 ¹⁾	(IE1-)B20R 200 L2 ¹⁾	M250/891.010.1	310
55.0	(IE1-)B21R 250 M2 ¹⁾	(IE1-)B20R 225 M2 ¹⁾	M500/891.010.1	500
75.0	(IE1-)B21R 280 S2 ¹⁾	(IE1-)B20R 250 S2 ¹⁾	-	-
90.0	(IE1-)B21R 280 M2 ¹⁾	(IE1-)B20R 250 M2 ¹⁾	-	-
Synchronous speed 1500 rpm – 4-pole version				
5.5	(IE1-)B21R 132 S4	(IE1-)B20R 112 M4	M32/891.010.1	64
7.5	(IE1-)B21R 132 M4	(IE1-)B20R 132 S4	M60/891.010.1	100
11.0	(IE1-)B21R 160 M4	(IE1-)B20R 132 M4	M100/891.010.1	180
15.0	(IE1-)B21R 160 L4	(IE1-)B20R 160 S4	M100/891.010.1	180
18.5	(IE1-)B21R 180 M4	(IE1-)B20R 160 M4	M150/891.010.1	250
22.0	(IE1-)B21R 180 L4	(IE1-)B20R 180 S4	M250/891.010.1	310
30.0	(IE1-)B21R 200 L4	(IE1-)B20R 180 M4	M250/891.010.1	450
37.0	(IE1-)B21R 225 S4	(IE1-)B20R 200 M4	M250/891.010.1	450
45.0	(IE1-)B21R 225 M4	(IE1-)B20R 200 L4	M500/891.010.1	500
55.0	(IE1-)B21R 250 M4	(IE1-)B20R 225 M4	M500/891.010.1	500
75.0	(IE1-)B21R 280 S4	(IE1-)B20R 250 S4	M500/891.010.1	500
90.0	(IE1-)B21R 280 M4	(IE1-)B20R 250 M4	M500/891.010.1	750
Synchronous speed 1000 rpm – 6-pole version				
3.0	(IE1-)B21R 132 S6	(IE1-)B20R 112 M6	M32/891.010.1	64
4.0	(IE1-)B21R 132 M6	(IE1-)B20R 112 MX6	M60/891.010.1	100
5.5	(IE1-)B21R 132 MX6	(IE1-)B20R 132 S6	M60/891.010.1	100
7.5	(IE1-)B21R 160 M6	(IE1-)B20R 132 M6	M100/891.010.1	180
11.0	(IE1-)B21R 160 L6	(IE1-)B20R 160 S6	M150/891.010.1	250
15.0	(IE1-)B21R 180 L6	(IE1-)B20R 160 M6	M250/891.010.1	310
18.5	(IE1-)B21R 200 L6	(IE1-)B20R 180 S6	M250/891.010.1	450
22.0	(IE1-)B21R 200 LX6	(IE1-)B20R 180 M6	M250/891.010.1	450
30.0	(IE1-)B21R 225 M6	(IE1-)B20R 200 M6	M500/891.010.1	500
37.0	(IE1-)B21R 250 M6	(IE1-)B20R 225 M6	M500/891.010.1	500
45.0	(IE1-)B21R 280 S6	(IE1-)B20R 250 S6	M500/891.010.1	500
55.0	(IE1-)B21R 280 M6	(IE1-)B20R 250 M6	M500/891.010.1	560
Synchronous speed 750 rpm – 8-pole version				
2.2	(IE1-)B21R 132 S8	(IE1-)B20R 112 M8	M32/891.010.1	64
3.0	(IE1-)B21R 132 M8	(IE1-)B20R 112 MX8	M60/891.010.1	100
4.0	(IE1-)B21R 160 M8	(IE1-)B20R 132 S8	M60/891.010.1	100
5.5	(IE1-)B21R 160 MX8	(IE1-)B20R 132 M8	M100/891.010.1	180
7.5	(IE1-)B21R 160 L8	(IE1-)B20R 160 S8	M100/891.010.1	180
11.0	(IE1-)B21R 180 L8	(IE1-)B20R 160 M8	M250/891.010.1	310
15.0	(IE1-)B21R 200 L8	(IE1-)B20R 180 S8	M250/891.010.1	450
18.5	-	(IE1-)B20R 180 M8	M250/891.010.1	-
18.5	(IE1-)B21R 225 S8	-	M250/891.010.1	450
22.0	(IE1-)B21R 225 M8	(IE1-)B20R 200 M8	M500/891.010.1	500
30.0	(IE1-)B21R 250 M8	(IE1-)B20R 225 M8	M500/891.010.1	500
37.0	(IE1-)B21R 280 S8	(IE1-)B20R 250 S8	M500/891.010.1	500
45.0	(IE1-)B21R 280 M8	(IE1-)B20R 250 M8	M500/891.010.1	700

Corresponding basic version plus brake

¹⁾ Requires consultation regarding application

(IE1-) can be supplied with and without marking of IE classification

Fan assignments

Built-on fans, type of cooling IC 416, Fan unit FBW (Wistro) for squirrel-cage motors, 2-pole

Premium Efficiency IE3/High Efficiency IE2/Standard Efficiency IE1 according to IEC/EN 60034-30-1

PB kW	Series				Fan unit
	For motor IE3-	For motor IE2-	For motor (IE1-)K.1R	For motor (IE1-)K.0R	
0.12	IE3-W.1F 56 G2	IE2-W.2F 56 G2	***)	***)	FBW 63
0.18	IE3-W.2F 63 K2	IE2-W.2F 63 K2	***)	***)	FBW 63
0.25	-	IE2-W.2F 63 G2	***)	***)	FBW 63
0.25	IE3-W.1F 63 G2	-	***)	***)	FBW 71
0.37	IE3-W.2F 71 K2	IE2-W.2F 71 K2	***)	***)	FBW 71
0.55	-	IE2-W.1F 71 G2	***)	***)	FBW 71
0.55	IE3-W.1F 71 GY2	-	***)	***)	FBW 80
0.75	-	-	(IE1-)K.1F 80 K2	(IE1-)K.0F 71 K2	FBW 80
0.75	IE3-W.1F 80 K2	IE2-W.1F 80 K2	-	-	FBW 90
1.1	-	-	(IE1-)K.1F 80 G2	(IE1-)K.0F 71 G2	FBW 80
1.1	IE3-W.1F 80 G2	IE2-W.1F 80 G2	-	-	FBW 90
1.5	-	-	(IE1-)K.1F 90 S2	(IE1-)K.0F 80 K2	FBW 90
1.5	IE3-W.1F 90 S2	IE2-W.1F 90 S2	-	-	FBW 100
2.2	-	-	(IE1-)K.1F 90 L2	(IE1-)K.0F 80 G2	FBW 90
2.2	IE3-W.1F 90 L2	IE2-W.1F 90 L2	-	-	FBW 100
3.0	-	-	(IE1-)K.1F 100 L2	(IE1-)K.0F 90 L2	FBW 100
3.0	IE3-W.1F 100 L2	IE2-W.1F 100 L2	-	-	FBW 112
4.0	-	-	(IE1-)K.1F 112 M2	(IE1-)K.0F 100 S2	FBW 100
4.0	IE3-W.1F 112 M2	-	-	-	FBW 112
4.0	-	IE2-W.1F 112 MX2	(IE1-)K.1F 112 MX2	(IE1-)K.0F 100 L2	FBW 112
5.5	IE3-W.1F 132 S2	IE2-W.1F 132 S2T	(IE1-)K.1F 132 S2T	-	FBW 112 IL
7.5	IE3-W.1F 132 SX2	-	(IE1-)K.1F 132 SX2T	-	FBW 112 IL
11.0	-	-	(IE1-)K.1F 160 M2	(IE1-)K.0F 132 M2	FBW 132 IL
11.0	IE3-W.1F 160 M2	IE2-W.1F 160 M2	-	-	FBW 160 IL
15.0	IE3-W.1F 160 MX2	IE2-W.1F 160 MX2	(IE1-)K.1F 160 MX2	(IE1-)K.0F 160 S2	FBW 160 IL
18.5	IE3-W.1F 160 L2	IE2-W.1F 160 L2	(IE1-)K.1F 160 L2	(IE1-)K.0F 160 M2	FBW 160 IL
22.0	IE3-W.1F 180 M2C	IE2-W.1F 180 M2	(IE1-)K.1F 180 M2	(IE1-)K.0F 180 S2	FBW 180 IL
30.0	-	IE2-W.1F 200 L2	(IE1-)K.1F 200 L2	(IE1-)K.0F 180 M2	FBW 180 IL
30.0	IE3-W.1F 200 L2	-	-	-	FBW 200 IL
37.0	IE3-W.1F 200 LX2C	-	(IE1-)K.1F 200 LX2	(IE1-)K.0F 200 M2	FBW 200 IL
37.0	-	IE2-W.1F 200 LX2	-	-	FBW 180 IL
45.0	-	IE2-W.1F 225 M2	(IE1-)K.1F 225 M2	(IE1-)K.0F 200 L2	FBW 200 IL
45.0	IE3-W.1F 225 M2	-	-	-	FBW 225 IL
55.0	-	IE2-W.1F 250 M2	(IE1-)K.1F 250 M2	(IE1-)K.0F 225 M2	FBW 225 IL
55.0	IE3-W.1F 250 M2	-	-	-	FBW 250 IL
75.0	IE3-W.1F 280 S2	IE2-W.1F 280 S2	(IE1-)K.1F 280 S2	(IE1-)K.0F 250 S2	FBW 250 IL
90.0	IE3-W.1F 280 M2	IE2-W.1F 280 M2	(IE1-)K.1F 280 M2	(IE1-)K.0F 250 M2	FBW 250 IL
110.0	IE3-W.1F 315 S2	IE2-W.1F 315 S2	(IE1-)K.1F 315 S2	(IE1-)K.0F 280 S2	FBW 280 IL
132.0	IE3-W.1F 315 M2	IE2-W.1F 315 M2	(IE1-)K.1F 315 M2	(IE1-)K.0F 280 M2	FBW 280 IL
160.0	IE3-W.1F 315 MX2	IE2-W.1F 315 MX2	(IE1-)K.1F 315 MX2	(IE1-)K.0F 315 S2	FBW 280 IL
200.0	IE3-W.1F 315 MY2	IE2-W.1F 315 MY2	(IE1-)K.1F 315 MY2	(IE1-)K.0F 315 M2	FBW 315 MY IL
250.0	IE3-W.1F 315 L2	IE2-W.1F 315 L2	(IE1-)K.1F 315 L2	(IE1-)K.0F 315 L2	FBW 315 MY IL
315.0	IE3-W.1F 315 LX2	IE2-W.1F 315 LX2	(IE1-)K.1F 315 LX2	(IE1-)K.0F 315 LX2	FBW 315 LX IL
315.0	-	IE2-W.2F 355 MY2	(IE1-)K.2F 355 MY2	-	FBW 355 IL
355.0	IE3-W.1F 355 M2	IE2-W.2F 355 M2	(IE1-)K.2F 355 M2	-	FBW 355 IL
400.0	IE3-W.2F 355 MX2	IE2-W.2F 355 MX2	(IE1-)K.2F 355 MX2	-	FBW 355 IL
450.0	-	IE2-W.2F 355 LY2	(IE1-)K.2F 355 LY2	-	FBW 355 IL
500.0	IE3-W.2F 355 L2	IE2-W.2F 355 L2	(IE1-)K.2F 355 L2	-	FBW 355 IL

Corresponding basic version plus fan

Motors with forced ventilation must always be provided with thermal motor protection.

Observe catalogue data regarding outputs in converter-fed operation.

In accordance with Regulation (EC) No. 640/2009, motors in 2-, 4- and 6-pole versions for outputs from 0.75 to 355 kW may only be brought onto the market if they do not fall within the scope of applicability of the regulation on account of the operating conditions specified by the customer.

(IE1-) can be supplied with and without marking of IE classification

***) upon request

Built-on fans, type of cooling IC 416, Fan unit FBW (Wistro) for squirrel-cage motors, 4-pole

Premium Efficiency IE3/High Efficiency IE2/Standard Efficiency IE1 according to IEC/EN 60034-30-1

PB kW	Series				Fan unit
	For motor IE3-	For motor IE2-	For motor (IE1-)K.1R	For motor (IE1-)K.0R	
0.12	IE3-W.2F 63 K4	IE2-W.2F 63 K4	***)	***)	FBW 63
0.18	IE3-W.1F 63 G4	IE2-W.1F 63 GY4	***)	***)	FBW 71
0.25	IE3-W.2F 71 K4	IE2-W.1F 71 K4	(IE1-)K.1F 71 K4	(IE1-)K.OF 63 K4	FBW 71
0.37	-	-	(IE1-)K.1F 71 G4	(IE1-)K.OF 63 G4	FBW 71
0.37	IE3-W.1F 71 GY4	IE2-W.1F 71 GY4	-	-	FBW 80
0.55	-	IE2-W.1F 80 K4	(IE1-)K.1F 80 K4	(IE1-)K.OF 71 K4	FBW 80
0.75	-	-	(IE1-)K.1F 80 G4	(IE1-)K.OF 71 G4	FBW 80
0.75	IE3-W.1F 80 GX4	IE2-W.1F 80 G4	-	-	FBW 90
1.1	-	-	(IE1-)K.1F 90 S4	(IE1-)K.OF 80 K4	FBW 90
1.1	IE3-W.1F 90 S4	IE2-W.1F 90 S4	-	-	FBW 100
1.5	-	-	(IE1-)K.1F 90 L4	(IE1-)K.OF 80 G4	FBW 90
1.5	IE3-W.1F 90 LX4	IE2-W.1F 90 L4	-	-	FBW 100
2.2	-	-	(IE1-)K.1F 100 L4	(IE1-)K.OF 90 L4	FBW 100
2.2	IE3-W.1F 100 L4	IE2-W.1F 100 L4	-	-	FBW 112
3.0	IE3-W.1F 100 LZ4	IE2-W.1F 100 LX4	(IE1-)K.1F 100 LX4	(IE1-)K.OF 100 S4	FBW 112
4.0	-	IE2-W.1F 112 MZ4	(IE1-)K.1F 112 M4	(IE1-)K.OF 100 L4	FBW 112
4.0	IE3-W.1F 112 M4	IE2-W.1F 112 M4	-	-	FBW 112
5.5	-	-	(IE1-)K.1F 132 S4	(IE1-)K.OF 112 M4	FBW 112 IL
5.5	IE3-W.1F 132 S4	IE2-W.2F 132 S4	-	-	FBW 132 IL
7.5	IE3-W.1F 132 M4	IE2-W.1F 132 M4	(IE1-)K.1F 132 M4	(IE1-)K.OF 132 S4	FBW 132 IL
11.0	-	-	(IE1-)K.1F 160 M4	(IE1-)K.OF 132 M4	FBW 132 IL
11.0	IE3-W.1F 160 M4	IE2-W.2F 160 M4	-	-	FBW 160 IL
15.0	IE3-W.1F 160 L4C	IE2-W.2F 160 L4	(IE1-)K.1F 160 L4	(IE1-)K.OF 160 S4	FBW 160 IL
18.5	-	-	(IE1-)K.1F 180 M4	(IE1-)K.OF 160 M4	FBW 160 IL
18.5	IE3-W.1F 180 M4	IE2-W.1F 180 M4	-	-	FBW 180 IL
22.0	IE3-W.1F 180 L4	IE2-W.1F 180 L4	(IE1-)K.1F 180 L4	(IE1-)K.OF 180 S4	FBW 180 IL
30.0	-	-	(IE1-)K.1F 200 L4	(IE1-)K.OF 180 M4	FBW 180 IL
30.0	IE3-W.1F 200 L4C	IE2-W.1F 200 L4	-	-	FBW 200 IL
37.0	IE3-W.1F 225 S4C	IE2-W.1F 225 S4	(IE1-)K.1F 225 S4	(IE1-)K.OF 200 M4	FBW 200 IL
45.0	-	-	(IE1-)K.1F 225 M4	(IE1-)K.OF 200 L4	FBW 200 IL
45.0	IE3-W.1F 225 M4	IE2-W.2F 225 M4	-	-	FBW 225 IL
55.0	-	IE2-W.2F 250 M4	(IE1-)K.1F 250 M4	(IE1-)K.OF 225 M4	FBW 225 IL
55.0	IE3-W.1F 250 M4	-	-	-	FBW 250 IL
75.0	IE3-W.1F 280 S4	IE2-W.1F 280 S4	(IE1-)K.1F 280 S4	(IE1-)K.OF 250 S4	FBW 250 IL
90.0	-	IE2-W.1F 280 M4	(IE1-)K.1F 280 M4	(IE1-)K.OF 250 M4	FBW 250 IL
90.0	IE3-W.1F 280 M4	-	-	-	FBW 280 IL
110.0	IE3-W.1F 315 S4	IE2-W.1F 315 S4	(IE1-)K.1F 315 S4	(IE1-)K.OF 280 S4	FBW 280 IL
132.0	IE3-W.1F 315 M4	IE2-W.1F 315 M4	(IE1-)K.1F 315 M4	(IE1-)K.OF 280 M4	FBW 280 IL
160.0	IE3-W.1F 315 MX4	IE2-W.1F 315 MX4	(IE1-)K.1F 315 MX4	(IE1-)K.OF 315 S4	FBW 280 IL
200.0	IE3-W.1F 315 MY4	IE2-W.1F 315 MY4	(IE1-)K.1F 315 MY4	(IE1-)K.OF 315 M4	FBW 315 MY IL
250.0	IE3-W.1F 315 L4	IE2-W.1F 315 L4	(IE1-)K.1F 315 L4	(IE1-)K.OF 315 L4	FBW 315 MY IL
315.0	IE3-W.1F 315 LX4	IE2-W.1F 315 LX4	(IE1-)K.1F 315 LX4	(IE1-)K.OF 315 LX4	FBW 315 LX IL
315.0	-	IE2-W.2F 355 MY4	(IE1-)K.2F 355 MY4	-	FBW 355 IL
355.0	IE3-W.1F 355 M4	IE2-W.2F 355 M4	(IE1-)K.2F 355 M4	-	FBW 355 IL
400.0	IE3-W.2F 355 MX4	IE2-W.2F 355 MX4	(IE1-)K.2F 355 MX4	-	FBW 355 IL
450.0	-	IE2-W.2F 355 LY4	(IE1-)K.2F 355 LY4	-	FBW 355 IL
500.0	IE3-W.2F 355 L4	IE2-W.2F 355 L4	(IE1-)K.2F 355 L4	-	FBW 355 IL

Corresponding basic version plus fan

Motors with forced ventilation must always be provided with thermal motor protection.

Observe catalogue data regarding outputs in converter-fed operation.

In accordance with Regulation (EC) No. 640/2009, motors in 2-, 4- and 6-pole versions for outputs from 0.75 to 355 kW may only be brought onto the market if they do not fall within the scope of applicability of the regulation on account of the operating conditions specified by the customer.

(IE1-) can be supplied with and without marking of IE classification

***) upon request

Built-on fans, type of cooling IC 416, Fan unit FBW (Wistro) for squirrel-cage motors, 6-pole

Premium Efficiency IE3/High Efficiency IE2/Standard Efficiency IE1 according to IEC/EN 60034-30-1

PB kW	Series				Fan unit
	For motor IE3-	For motor IE2-	For motor (IE1-)K.1R	For motor (IE1-)K.0R	
0.12		IE2-W.2F 63 G6	***)	***)	FBW 63
0.12	IE3-W.1F 63 G6	-	***)	***)	FBW 71
0.18	IE3-W.2F 71 KY6	IE2-W.2F 71 K6	(IE1-)K.1F 71 K6	(IE1-)K.0F 63 K6	FBW 71
0.25	-	IE2-W.1F 71 G6	(IE1-)K.1F 71 G6	(IE1-)K.0F 63 G6	FBW 71
0.25	IE3-W.1F 71 GY6	-	-	-	FBW 80
0.37	-	IE2-W.1F 80 K6	(IE1-)K.1F 80 K6	(IE1-)K.0F 71 K6	FBW 80
0.37	IE3-W.1F 80 K6	-	-	-	FBW 90
0.37	-	-	(IE1-)K.1F 80 G6	(IE1-)K.0F 71 G6	FBW 80
0.55	IE3-W.1F 80 G6	IE2-W.1F 80 GY6	-	-	FBW 90
0.75	-	-	(IE1-)K.1F 90 S6	(IE1-)K.0F 80 K6	FBW 90
0.75	IE3-W.1F 90 S6	IE2-W.1F 90 S6	-	-	FBW 100
1.1	-	-	(IE1-)K.1F 90 L6	(IE1-)K.0F 80 G6	FBW 90
1.1	IE3-W.1F 90 L6	IE2-W.1F 90 L6	-	-	FBW 100
1.5	-	-	(IE1-)K.1F 100 L6	(IE1-)K.0F 90 L6	FBW 100
1.5	IE3-W.1F 100 L6	-	-	-	FBW 112
1.5	-	IE2-W.1F 100 LX6	-	-	FBW 112
2.2	IE3-W.1F 112 MZ6	IE2-W.1F 112 MV6	(IE1-)K.1F 112 M6	(IE1-)K.0F 100 L6	FBW 112
3.0	IE3-W.1F 132 S6	IE2-W.1F 132 S6	(IE1-)K.1F 132 S6T	-	FBW 112 IL
4.0	-	-	(IE1-)K.1F 132 M6	(IE1-)K.0F 112 MX6	FBW 112 IL
4.0	IE3-W.1F 132 M6	IE2-W.2F 132 M6	-	-	FBW 132 IL
5.5	IE3-W.1F 132 MX6	IE2-W.1F 132 MX6	(IE1-)K.1F 132 MX6	(IE1-)K.0F 132 S6	FBW 132 IL
7.5	-	-	(IE1-)K.1F 160 M6	(IE1-)K.0F 132 M6	FBW 132 IL
7.5	IE3-W.1F 160 M6	IE2-W.2F 160 M6	-	-	FBW 160 IL
11.0	IE3-W.1F 160 L6C	IE2-W.1F 160 L6	(IE1-)K.1F 160 L6	(IE1-)K.0F 160 S6	FBW 160 IL
15.0	-	-	(IE1-)K.1F 180 L6	(IE1-)K.0F 160 M6	FBW 160 IL
15.0	IE3-W.1F 180 L6C	IE2-W.2F 180 L6	-	-	FBW 180 IL
18.5	-	IE2-W.1F 200 L6	(IE1-)K.1F 200 L6	(IE1-)K.0F 180 S6	FBW 180 IL
18.5	-	-	(IE1-)K.1F 200 LX6	(IE1-)K.0F 180 M6	FBW 180 IL
18.5	IE3-W.1F 200 L6C	-	-	-	FBW 200 IL
22.0	IE3-W.1F 200 LX6C	IE2-W.2F 200 LX6	-	-	FBW 200 IL
30.0	-	-	(IE1-)K.1F 225 M6	(IE1-)K.0F 200 M6	FBW 200 IL
30.0	IE3-W.1F 225 M6	IE2-W.2F 225 M6	-	-	FBW 225 IL
37.0	-	-	(IE1-)K.1F 250 M6	(IE1-)K.0F 225 M6	FBW 225 IL
37.0	IE3-W.1F 250 M6	IE2-W.2F 250 M6	-	-	FBW 250 IL
45.0	-	IE2-W.2F 280 S6	(IE1-)K.1F 280 S6	(IE1-)K.0F 250 S6	FBW 250 IL
45.0	IE3-W.1F 280 S6	-	-	-	FBW 280 IL
55.0	-	-	(IE1-)K.1F 280 M6	(IE1-)K.0F 250 M6	FBW 250 IL
55.0	IE3-W.1F 280 M6	IE2-W.2F 280 M6	-	-	FBW 280 IL
75.0	IE3-W.1F 315 S6	IE2-W.2F 315 S6	(IE1-)K.1F 315 S6	(IE1-)K.0F 280 S6	FBW 280 IL
90.0	-	IE2-W.2F 315 M6	(IE1-)K.1F 315 M6	(IE1-)K.0F 280 M6	FBW 280 IL
90.0	IE3-W.1F 315 M6	-	-	-	FBW 315 MY IL
110.0	-	-	(IE1-)K.1F 315 MX6	(IE1-)K.0F 315 S6	FBW 280 IL
110.0	IE3-W.1F 315 MX6	IE2-W.1F 315 MX6	-	-	FBW 315 MY IL
132.0	-	IE2-W.1F 315 MY6	(IE1-)K.1F 315 MY6	(IE1-)K.0F 315 M6	FBW 315 MY IL
132.0	IE3-W.1F 315 L6	IE2-W.1F 315 L6	(IE1-)K.1F 315 L6	(IE1-)K.0F 315 L6	FBW 315 MY IL
200.0	-	IE2-W.1F 315 LX6	(IE1-)K.1F 315 LX6	(IE1-)K.0F 315 LX6	FBW 315 MY IL
200.0	-	IE2-W.2F 355 MY6	(IE1-)K.2F 355 MY6	-	FBW 355 IL
160.0	W.1F 355 M6	IE2-W.2F 355 M6	(IE1-)K.2F 355 M6	-	FBW 355 IL
200.0	W.2F 355 MX6	IE2-W.2F 355 MX6	(IE1-)K.2F 355 MX6	-	FBW 355 IL
250.0	W.2F 355 L6	IE2-W.2F 355 LY6	(IE1-)K.2F 355 LY6	-	FBW 355 IL

Corresponding basic version plus fan

Motors with forced ventilation must always be provided with thermal motor protection.

Observe catalogue data regarding outputs in converter-fed operation.

In accordance with Regulation (EC) No. 640/2009, motors in 2-, 4- and 6-pole versions for outputs from 0.75 to 355 kW may only be brought onto the market if they do not fall within the scope of applicability of the regulation on account of the operating conditions specified by the customer.

(IE1-) can be supplied with and without marking of IE classification

***) upon request

Built-on fans, type of cooling IC 416, Fan unit FBW (Wistro) for squirrel-cage motors, 8-pole

Premium Efficiency IE3/High Efficiency IE2/Standard Efficiency IE1 according to IEC/EN 60034-30-1

PB kW	Series				Fan unit
	For motor IE3-	For motor IE2-	For motor (IE1-)K.1R	For motor (IE1-)K.OR	
0.12	-	-	(IE1-)K.1F 71 K8	(IE1-)K.OF 63 K8	FBW 71
0.12	-	IE2-W.2F 71 G8	(IE1-)K.1F 71 G8	(IE1-)K.OF 63 G8	FBW 71
0.12	IE3-W.1F 71 G8	-	-	-	FBW 80
0.18	IE3-W.2R 80 K8	IE2-W.1F 80 K8	(IE1-)K.1F 80 K8	(IE1-)K.OF 71 K8	FBW 80
0.25	-	IE2-W.1F 80 G8	(IE1-)K.1F 80 G8	(IE1-)K.OF 71 G8	FBW 80
0.25	IE3-W.1F 80 G8	-	-	-	FBW 90
0.37	IE3-W.2F 90 S8	IE2-W.1F 90 S8	(IE1-)K.1F 90 S8	(IE1-)K.OF 80 K8	FBW 90
0.55	-	IE2-W.1F 90 L8	(IE1-)K.1F 90 L8	(IE1-)K.OF 80 G6	FBW 90
0.55	IE3-W.1F 90 L8	-	-	-	FBW 100
0.75	-	-	(IE1-)K.1F 100 L8	(IE1-)K.OF 90 L8	FBW 100
0.75	IE3-W.1F 100 LY8	IE2-W.1F 100 L8	-	-	FBW 112
1.1	IE3-W.1F 100 LV8	IE2-W.1F 100 LY8	(IE1-)K.1F 100 LX8	(IE1-)K.OF 100 S8	FBW 112
1.5	IE3-W.1F 112 M8	IE2-W.1F 112 M8	(IE1-)K.1F 112 M8	(IE1-)K.OF 100 L8	FBW 112
2.2	IE3-W.1F 132 S8	IE2-W.1F 132 S8	(IE1-)K.1F 132 S8	(IE1-)K.OF 112 M8	FBW 112 IL
3.0	-	-	(IE1-)K.1F 132 M8	(IE1-)K.OF 112 MX8	FBW 112 IL
3.0	IE3-W.1F 132 M8	IE2-W.2F 132 M8	-	-	FBW 132 IL
4.0	IE3-W.1F 160 M8	IE2-W.1F 160 M8	(IE1-)K.1F 160 M8	(IE1-)K.OF 132 S8	FBW 132 IL
5.5	-	-	(IE1-)K.1F 160 MX8	(IE1-)K.OF 132 M8	FBW 132 IL
5.5	IE3-W.1F 160 MX8	IE2-W.2F 160 MX8	-	-	FBW 160 IL
7.5	IE3-W.1F 160 L8C	IE2-W.1F 160 L8	(IE1-)K.1F 160 L8	(IE1-)K.OF 160 S8	FBW 160 IL
11.0	-	-	(IE1-)K.1F 180 L8	(IE1-)K.OF 160 M8	FBW 160 IL
11.0	IE3-W.1F 180 L8	IE2-W.2F 180 L8	-	-	FBW 180 IL
15.0	IE3-W.1F 200 L8	IE2-W.1F 200 L8	(IE1-)K.1F 200 L8	(IE1-)K.OF 180 S8	FBW 180 IL
18.5	IE3-W.1F 225 S8	IE2-W.2F 225 S8	(IE1-)K.1F 225 S8	(IE1-)K.OF 180 M8	FBW 200 IL
22.0	-	-	(IE1-)K.1F 225 M8	(IE1-)K.OF 200 M8	FBW 200 IL
22.0	IE3-W.1F 225 M8	IE2-W.2F 225 M8	-	-	FBW 225 IL
30.0	-	-	(IE1-)K.1F 250 M8	(IE1-)K.OF 225 M8	FBW 225 IL
30.0	IE3-W.1F 250 M8	IE2-W.2F 250 M8	-	-	FBW 250 IL
37.0	-	IE2-W.1F 280 S8	(IE1-)K.1F 280 S8	(IE1-)K.OF 250 S8	FBW 250 IL
37.0	IE3-W.1F 280 S8	-	-	-	FBW 280 IL
45.0	-	-	(IE1-)K.1F 280 M8	(IE1-)K.OF 250 M8	FBW 250 IL
45.0	IE3-W.1F 280 M8	IE2-W.1F 280 M8	-	-	FBW 280 IL
55.0	IE3-W.1F 315 S8	IE2-W.1F 315 S8	(IE1-)K.1F 315 S8	(IE1-)K.OF 280 S8	FBW 280 IL
75.0	-	IE2-W.1F 315 M8	(IE1-)K.1F 315 M8	(IE1-)K.OF 280 M8	FBW 280 IL
75.0	IE3-W.1F 315 M8	-	-	-	FBW 315 MY IL
90.0	-	-	(IE1-)K.1F 315 MX8	(IE1-)K.OF 315 S8	FBW 280 IL
90.0	IE3-W.1F 315 MX8	IE2-W.1F 315 MX8	-	-	FBW 315 MY IL
110.0	IE3-W.1F 315 MY8	IE2-W.1F 315 MY8	(IE1-)K.1F 315 MY8	(IE1-)K.OF 315 M8	FBW 315 MY IL
110.0	IE3-W.1F 315 L8	IE2-W.1F 315 L8	(IE1-)K.1F 315 L8	(IE1-)K.OF 315 L8	FBW 315 MY IL
160.0	-	IE2-W.1F 315 LX8	(IE1-)K.1F 315 LX8	(IE1-)K.OF 315 LX8	FBW 315 MY IL
132.0	IE3-W.1F 355 MY8	IE2-W.2F 355 MY8	(IE1-)K.2F 355 MY8	-	FBW 355 IL
132.0	IE3-W.1F 355 M8	IE2-W.2F 355 M8	(IE1-)K.2F 355 M8	-	FBW 355 IL
160.0	IE3-W.2F 355 MX8	IE2-W.2F 355 MX8	(IE1-)K.2F 355 MX8	-	FBW 355 IL
200.0	IE3-W.2F 355 L8	IE2-W.2F 355 LY8	(IE1-)K.2F 355 LY8	-	FBW 355 IL

Corresponding basic version plus fan

Motors with forced ventilation must always be provided with thermal motor protection.

Observe catalogue data regarding outputs in converter-fed operation.

In accordance with Regulation (EC) No. 640/2009, motors in 2-, 4- and 6-pole versions for outputs from 0.75 to 355 kW may only be brought onto the market if they do not fall within the scope of applicability of the regulation on account of the operating conditions specified by the customer. (IE1-) can be supplied with and without marking of IE classification

Built-on fans, type of cooling IC 416, Fan unit FBI/MMP (Maier) for squirrel-cage motors, 2-pole

Premium Efficiency IE3/High Efficiency IE2/Standard Efficiency IE1 according to IEC/EN 60034-30-1

PB kW	Series				Fan unit
	For motor IE3-	For motor IE2-	For motor (IE1-)K.1R	For motor (IE1-)K.OR	
0.12	IE3-W.1F 56 G2	IE2-W.2F 56 G2	***)	***)	FBI 63-2
0.18	IE3-W.2F 63 K2	IE2-W.2F 63 K2	***)	***)	FBI 63-2
0.25	-	IE2-W.2F 63 G2	***)	***)	FBI 63-2
0.25	IE3-W.1F 63 G2	-	***)	***)	FBI 63-2
0.37	-	-	(IE1-)K.1F 71 K2	(IE1-)K.OF 63 K2	FBI 63-2
0.37	-	IE2-W.1F 71 K2	-	-	FBI 71-2
0.55	-	-	(IE1-)K.1F 71 G2	(IE1-)K.OF 63 G2	FBI 63-2
0.55	-	IE2-W.1F 71 G2	-	-	FBI 71-2
0.75	-	-	(IE1-)K.1F 80 K2	(IE1-)K.OF 71 K2	FBI 71-2
0.75	IE3-W.1F 80 K2	IE2-W.1F 80 K2	-	-	FBI 80-2
1.1	-	-	(IE1-)K.1F 80 G2	(IE1-)K.OF 71 G2	FBI 71-2
1.1	IE3-W.1F 80 G2	IE2-W.1F 80 G2	-	-	FBI 80-2
1.5	-	-	(IE1-)K.1F 90 S2	(IE1-)K.OF 80 K2	FBI 80-2
1.5	IE3-W.1F 90 S2	IE2-W.1F 90 S2	-	-	FBI 90-2
2.2	-	-	(IE1-)K.1F 90 L2	(IE1-)K.OF 80 G2	FBI 80-2
2.2	IE3-W.1F 90 L2	IE2-W.1F 90 L2	-	-	FBI 90-2
3.0	-	-	(IE1-)K.1F 100 L2	(IE1-)K.OF 90 L2	FBI 90-2
3.0	IE3-W.1F 100 L2	IE2-W.1F 100 L2	-	-	FBI 100-2
4.0	-	-	(IE1-)K.1F 112 M2	(IE1-)K.OF 100 S2	FBI 100-2
4.0	IE3-W.1F 112 M2	IE2-W.1F 112 MX2	(IE1-)K.1F 112 MX2	(IE1-)K.OF 100 L2	FBI 100-2
5.5	-	-	(IE1-)K.1F 132 S2T	-	FBI 100-2
5.5	IE3-W.1F 132 S2	IE2-W.1F 132 S2T	-	-	FBI 112-2
7.5	-	-	(IE1-)K.1F 132 SX2T	-	FBI 100-2
7.5	IE3-W.1F 132 SX2	-	-	-	FBI 132-2
11.0	IE3-W.1F 160 M2	IE2-W.1F 160 M2	(IE1-)K.1F 160 M2	(IE1-)K.OF 132 M2	FBI 160-2
15.0	IE3-W.1F 160 MX2	IE2-W.1F 160 MX2	(IE1-)K.1F 160 MX2	(IE1-)K.OF 160 S2	FBI 160-2
18.5	IE3-W.1F 160 L2	IE2-W.1F 160 L2	(IE1-)K.1F 160 L2	(IE1-)K.2R 160 M2	FBI 160-2
22.0	IE3-W.1F 180 M2C	IE2-W.1F 180 M2	(IE1-)K.1F 180 M2	(IE1-)K.OF 180 S2	FBI 180-2
30.0	-	IE2-W.1F 200 L2	(IE1-)K.1F 200 L2	(IE1-)K.OF 180 M2	FBI 200-2
30.0	IE3-W.1F 200 L2	-	-	-	FBI 180-2
37.0	IE3-W.1F 200 LX2C	IE2-W.1F 200 LX2	(IE1-)K.1F 200 LX2	(IE1-)K.OF 200 M2	FBI 180-2
45.0	-	IE2-W.1F 225 M2	(IE1-)K.1F 225 M2	(IE1-)K.OF 200 L2	FBI 200-2
45.0	IE3-W.1F 225 M2	-	-	-	-
55.0	-	IE2-W.1F 250 M2	(IE1-)K.1F 250 M2	(IE1-)K.OF 225 M2	FBI 250-4
55.0	IE3-W.1F 250 M2	-	-	-	FBI 280-25
75.0	IE3-W.1F 280 S2	IE2-W.1F 280 S2	(IE1-)K.1F 280 S2	(IE1-)K.OF 250 S2	FBI 280-13
90.0	IE3-W.1F 280 M2	IE2-W.1F 280 M2	(IE1-)K.1F 280 M2	(IE1-)K.OF 250 M2	FBI 280-13
110.0	IE3-W.1F 315 S2	IE2-W.1F 315 S2	(IE1-)K.1F 315 S2	(IE1-)K.OF 280 S2	FBI 315-14
132.0	IE3-W.1F 315 M2	IE2-W.1F 315 M2	(IE1-)K.1F 315 M2	(IE1-)K.OF 280 M2	FBI 315-14
160.0	IE3-W.1F 315 MX2	IE2-W.1F 315 MX2	(IE1-)K.1F 315 MX2	(IE1-)K.OF 315 S2	FBI 315-14
200.0	IE3-W.1F 315 MY2	IE2-W.1F 315 MY2	(IE1-)K.1F 315 MY2	(IE1-)K.OF 315 M2	FBI 315-23
250.0	IE3-W.1F 315 L2	IE2-W.1F 315 L2	(IE1-)K.1F 315 L2	(IE1-)K.OF 315 L2	FBI 315-23
315.0	IE3-W.1F 315 LX2	IE2-W.1F 315 LX2	(IE1-)K.1F 315 LX2	(IE1-)K.OF 315 LX2	FBI 315-24
315.0	-	IE2-W.2F 355 MY2	(IE1-)K.2F 355 MY2	-	FBI 355-26
355.0	IE3-W.1F 355 M2	IE2-W.2F 355 M2	(IE1-)K.2F 355 M2	-	FBI 355-26
400.0	IE3-W.2F 355 MX2	IE2-W.2F 355 MX2	(IE1-)K.2F 355 MX2	-	FBI 355-26
450.0	-	IE2-W.2F 355 LY2	(IE1-)K.2F 355 LY2	-	FBI 355-26
500.0	IE3-W.2F 355 L2	IE2-W.2F 355 L2	(IE1-)K.2F 355 L2	-	FBI 355-26

Corresponding basic version plus fan

Motors with forced ventilation must always be provided with thermal motor protection.

Observe catalogue data regarding outputs in converter-fed operation.

In accordance with Regulation (EC) No. 640/2009, motors in 2-, 4- and 6-pole versions for outputs from 0.75 to 355 kW may only be brought onto the market if they do not fall within the scope of applicability of the regulation on account of the operating conditions specified by the customer.

(IE1-) can be supplied with and without marking of IE classification

***) upon request

Built-on fans, type of cooling IC 416, Fan unit FBI/MMP (Maier) for squirrel-cage motors, 4-pole

Premium Efficiency IE3/High Efficiency IE2/Standard Efficiency IE1 according to IEC/EN 60034-30-1

PB kW	Series				Fan unit
	For motor IE3-	For motor IE2-	For motor (IE1-)K.1R	For motor (IE1-)K.OR	
0.12	IE3-W.2F 63 K4	IE2-W.2F 63 K4	***)	***)	***)
0.18	IE3-W.1F 63 G4	IE2-W.1F 63 GY4	***)	***)	***)
0.25	-	-	(IE1-)K.1F 71 K4	(IE1-)K.OF 63 K4	FBI 63-2
0.25	-	IE2-W.1F 71 K4	-	-	FBI 71-2
0.37	-	-	(IE1-)K.1F 71 G4	(IE1-)K.OF 63 G4	FBI 63-2
0.37	IE3-W.1F 71 GY4	IE2-W.1F 71 GY4	-	-	FBI 71-2
0.55	-	-	(IE1-)K.1F 80 K4	(IE1-)K.OF 71 K4	FBI 71-2
0.55	-	IE2-W.1F 80 K4	-	-	FBI 80-2
0.75	-	-	(IE1-)K.1F 80 G4	(IE1-)K.OF 71 G4	FBI 71-2
0.75	IE3-W.1F 80 GX4	IE2-W.1F 80 G4	-	-	FBI 80-2
1.1	-	-	(IE1-)K.1F 90 S4	(IE1-)K.OF 80 K4	FBI 80-2
1.1	IE3-W.1F 90 S4	IE2-W.1F 90 S4	-	-	FBI 90-2
1.5	-	-	(IE1-)K.1F 90 L4	(IE1-)K.OF 80 G4	FBI 80-2
1.5	IE3-W.1F 90 LX4	IE2-W.1F 90 L4	-	-	FBI 90-2
2.2	-	-	(IE1-)K.1F 100 L4	(IE1-)K.OF 90 L4	FBI 90-2
2.2	IE3-W.1F 100 L4	IE2-W.1F 100 L4	-	-	FBI 100-2
3.0	IE3-W.1F 100 LZ4	IE2-W.1F 100 LX4	(IE1-)K.1F 100 LX4	(IE1-)K.OF 100 S4	FBI 100-2
4.0	-	IE2-W.1F 112 MZ4	(IE1-)K.1F 112 M4	(IE1-)K.OF 100 L4	FBI 100-2
4.0	IE3-W.1F 112 M4	IE2-W.1F 112 M4	-	-	FBI 112-2
5.5	-	-	(IE1-)K.1F 132 S4	(IE1-)K.OF 112 M4	FBI 100-2
5.5	IE3-W.1F 132 S4	IE2-W.2F 132 S4	-	-	FBI 112-2
7.5	-	-	(IE1-)K.1F 132 M4	(IE1-)K.OF 132 S4	FBI 132-2
7.5	IE3-W.1F 132 M4	-	-	-	FBI 112-2
7.5	-	IE2-W.1F 132 M4	-	-	FBI 132-2
11.0	IE3-W.1F 160 M4	IE2-W.2F 160 M4	(IE1-)K.1F 160 M4	(IE1-)K.OF 132 M4	FBI 132-2
15.0	IE3-W.1F 160 L4C	IE2-W.2F 160 L4	(IE1-)K.1F 160 L4	(IE1-)K.OF 160 S4	FBI 132-2
18.5	-	-	(IE1-)K.1F 180 M4	(IE1-)K.OF 160 M4	FBI 160-2
18.5	IE3-W.1F 180 M4	IE2-W.1F 180 M4	-	-	FBI 180-2
22.0	IE3-W.1F 180 L4	IE2-W.1F 180 L4	(IE1-)K.1F 180 L4	(IE1-)K.OF 180 S4	FBI 180-2
30.0	-	-	(IE1-)K.1F 200 L4	(IE1-)K.OF 180 M4	FBI 200-2
30.0	IE3-W.1F 200 L4C	IE2-W.1F 200 L4	-	-	FBI 180-2
37.0	IE3-W.1F 225 S4C	IE2-W.1F 225 S4	(IE1-)K.1F 225 S4	(IE1-)K.OF 200 M4	FBI 200-4
45.0	-	-	(IE1-)K.1F 225 M4	(IE1-)K.OF 200 L4	FBI 200-4
45.0	IE3-W.1F 225 M4	IE2-W.2F 225 M4	-	-	-
55.0	-	IE2-W.2F 250 M4	(IE1-)K.1F 250 M4	(IE1-)K.OF 225 M4	FBI 250-4
55.0	IE3-W.1F 250 M4	-	-	-	FBI 280-25
75.0	IE3-W.1F 280 S4	IE2-W.1F 280 S4	(IE1-)K.1F 280 S4	(IE1-)K.OF 250 S4	FBI 280-13
90.0	-	IE2-W.1F 280 M4	(IE1-)K.1F 280 M4	(IE1-)K.OF 250 M4	FBI 280-13
90.0	IE3-W.1F 280 M4	-	-	-	-
110.0	IE3-W.1F 315 S4	IE2-W.1F 315 S4	(IE1-)K.1F 315 S4	(IE1-)K.OF 280 S4	FBI 315-14
132.0	IE3-W.1F 315 M4	IE2-W.1F 315 M4	(IE1-)K.1F 315 M4	(IE1-)K.OF 280 M4	FBI 315-14
160.0	IE3-W.1F 315 MX4	IE2-W.1F 315 MX4	(IE1-)K.1F 315 MX4	(IE1-)K.OF 315 S4	FBI 315-14
200.0	IE3-W.1F 315 MY4	IE2-W.1F 315 MY4	(IE1-)K.1F 315 MY4	(IE1-)K.OF 315 M4	FBI 315-23
250.0	IE3-W.1F 315 L4	IE2-W.1F 315 L4	(IE1-)K.1F 315 L4	(IE1-)K.OF 315 L4	FBI 315-23
315.0	IE3-W.1F 315 LX4	IE2-W.1F 315 LX4	(IE1-)K.1F 315 LX4	(IE1-)K.OF 315 LX4	FBI 315-24
315.0	-	IE2-W.2F 355 MY4	(IE1-)K.2F 355 MY4	-	FBI 355-26
355.0	IE3-W.1F 355 M4	IE2-W.2F 355 M4	(IE1-)K.2F 355 M4	-	FBI 355-26
400.0	IE3-W.2F 355 MX4	IE2-W.2F 355 MX4	(IE1-)K.2F 355 MX4	-	FBI 355-26
450.0	-	IE2-W.2F 355 LY4	(IE1-)K.2F 355 LY4	-	FBI 355-26
500.0	IE3-W.2F 355 L4	IE2-W.2F 355 L4	(IE1-)K.2F 355 L4	-	FBI 355-26

Corresponding basic version plus fan

Motors with forced ventilation must always be provided with thermal motor protection.

Observe catalogue data regarding outputs in converter-fed operation.

In accordance with Regulation (EC) No. 640/2009, motors in 2-, 4- and 6-pole versions for outputs from 0.75 to 355 kW may only be brought onto the market if they do not fall within the scope of applicability of the regulation on account of the operating conditions specified by the customer.

(IE1-) can be supplied with and without marking of IE classification

***) upon request

Built-on fans, type of cooling IC 416, Fan unit FBI/MMP (Maier) for squirrel-cage motors, 6-pole

Premium Efficiency IE3/High Efficiency IE2/Standard Efficiency IE1 according to IEC/EN 60034-30-1

PB kW	Series				Fan unit
	For motor IE3-	For motor IE2-	For motor (IE1-)K.1R	For motor (IE1-)K.OR	
0.12	-	IE2-W.2F 63 G6	***)	***)	***)
0.12	IE3-W.1F 63 G6	-	***)	***)	***)
0.18	IE3-W.2F 71 KY6	IE2-W.2F 71 K6	***)	***)	***)
0.18	-	-	(IE1-)K.1F 71 K6	(IE1-)K.OF 63 K6	FBI 63-2
0.25	-	-	(IE1-)K.1F 71 G6	(IE1-)K.OF 63 G6	FBI 63-2
0.25	-	IE2-W.1F 71 G6	***)	***)	***)
0.25	IE3-W.1F 71 GY6	-	-	-	FBI 71-2
0.37	-	-	(IE1-)K.1F 80 K6	(IE1-)K.OF 71 K6	FBI 71-2
0.37	-	IE2-W.1F 80 K6	-	-	FBI 80-2
0.55	-	-	(IE1-)K.1F 80 G6	(IE1-)K.OF 71 G6	FBI 71-2
0.55	-	IE2-W.1F 80 GY6	-	-	FBI 80-2
0.75	-	-	(IE1-)K.1F 90 S6	(IE1-)K.OF 80 K6	FBI 80-2
0.75	IE3-W.1F 90 S6	IE2-W.1F 90 S6	-	-	FBI 90-2
1.1	-	-	(IE1-)K.1F 90 L6	(IE1-)K.OF 80 G6	FBI 80-2
1.1	IE3-W.1F 90 L6	IE2-W.1F 90 L6	-	-	FBI 90-2
1.5	-	-	(IE1-)K.1F 100 L6	(IE1-)K.OF 90 L6	FBI 90-2
1.5	IE3-W.1F 100 L6	IE2-W.1F 100 LX6	-	-	FBI 100-2
2.2	IE3-W.1F 112 MZ6	IE2-W.1F 112 MV6	(IE1-)K.1F 112 M6	(IE1-)K.OF 100 L6	FBI 100-2
3.0	-	-	(IE1-)K.1F 132 S6T	-	FBI 100-2
3.0	IE3-W.1F 132 S6	IE2-W.1F 132 S6	-	-	FBI 112-2
4.0	IE3-W.1F 132 M6	IE2-W.2F 132 M6	(IE1-)K.1F 132 M6	(IE1-)K.OF 112 MX6	FBI 112-2
5.5	IE3-W.1F 132 MX6	IE2-W.1F 132 MX6	(IE1-)K.1F 132 MX6	(IE1-)K.OF 132 S6	FBI 112-2
7.5	IE3-W.1F 160 M6	IE2-W.2F 160 M6	(IE1-)K.1F 160 M6	(IE1-)K.OF 132 M6	FBI 132-2
11.0	-	-	(IE1-)K.1F 160 L6	(IE1-)K.OF 160 S6	FBI 160-2
11.0	IE3-W.1F 160 L6C	IE2-W.1F 160 L6	-	-	FBI 132-2
15.0	-	-	(IE1-)K.1F 180 L6	(IE1-)K.OF 160 M6	FBI 160-2
15.0	IE3-W.1F 180 L6C	IE2-W.2F 180 L6	-	-	FBI 180-2
18.5	-	IE2-W.1F 200 L6	(IE1-)K.1F 200 L6	(IE1-)K.OF 180 S6	FBI 200-2
18.5	-	-	(IE1-)K.1F 200 LX6	(IE1-)K.OF 180 M6	FBI 200-2
18.5	IE3-W.1F 200 L6C	-	-	-	FBI 180-2
22.0	IE3-W.1F 200 LX6C	IE2-W.2F 200 LX6	-	-	FBI 180-2
30.0	-	-	(IE1-)K.1F 225 M6	(IE1-)K.OF 200 M6	FBI 200-4
30.0	IE3-W.1F 225 M6	IE2-W.2F 225 M6	-	-	-
37.0	-	-	(IE1-)K.1F 250 M6	(IE1-)K.OF 225 M6	FBI 250-4
37.0	IE3-W.1F 250 M6	IE2-W.2F 250 M6	-	-	FBI 280-25
45.0	-	IE2-W.2F 280 S6	(IE1-)K.1F 280 S6	(IE1-)K.OF 250 S6	FBI 280-13
45.0	IE3-W.1F 280 S6	-	-	-	-
55.0	-	-	(IE1-)K.1F 280 M6	(IE1-)K.OF 250 M6	FBI 280-13
55.0	IE3-W.1F 280 M6	IE2-W.2F 280 M6	-	-	-
75.0	IE3-W.1F 315 S6	IE2-W.2F 315 S6	(IE1-)K.1F 315 S6	(IE1-)K.OF 280 S6	FBI 315-14
90.0	-	IE2-W.2F 315 M6	(IE1-)K.1F 315 M6	(IE1-)K.OF 280 M6	FBI 315-14
90.0	IE3-W.1F 315 M6	-	-	-	FBI 315-23
110.0	-	-	(IE1-)K.1F 315 MX6	(IE1-)K.OF 315 S6	FBI 315-14
110.0	IE3-W.1F 315 MX6	IE2-W.1F 315 MX6	-	-	FBI 315-23
132.0	-	IE2-W.1F 315 MY6	(IE1-)K.1F 315 MY6	(IE1-)K.OF 315 M6	FBI 315-23
132.0	IE3-W.1F 315 L6	IE2-W.1F 315 L6	(IE1-)K.1F 315 L6	(IE1-)K.OF 315 L6	FBI 315-23
200.0	-	IE2-W.1F 315 LX6	(IE1-)K.1F 315 LX6	(IE1-)K.OF 315 LX6	FBI 315-23
200.0	-	IE2-W.2F 355 MY6	(IE1-)K.2F 355 MY6	-	FBI 355-26
160.0	W.1F 355 M6	IE2-W.2F 355 M6	(IE1-)K.2F 355 M6	-	FBI 355-26
200.0	W.2F 355 MX6	IE2-W.2F 355 MX6	(IE1-)K.2F 355 MX6	-	FBI 355-26
250.0	W.2F 355 L6	IE2-W.2F 355 LY6	(IE1-)K.2F 355 LY6	-	FBI 355-26

Corresponding basic version plus fan

Motors with forced ventilation must always be provided with thermal motor protection.

Observe catalogue data regarding outputs in converter-fed operation.

In accordance with Regulation (EC) No. 640/2009, motors in 2-, 4- and 6-pole versions for outputs from 0.75 to 355 kW may only be brought onto the market if they do not fall within the scope of applicability of the regulation on account of the operating conditions specified by the customer.

(IE1-) can be supplied with and without marking of IE classification

***) upon request

Built-on fans, type of cooling IC 416, Fan unit FBI/MMP (Maier) for squirrel-cage motors, 8-pole

Premium Efficiency IE3/High Efficiency IE2/Standard Efficiency IE1 according to IEC/EN 60034-30-1

PB kW	Series				Fan unit
	For motor IE3-	For motor IE2-	For motor (IE1-)K.1R	For motor (IE1-)K.OR	
0.09	-	-	(IE1-)K.1F 71 K8	(IE1-)K.OF 63 K8	FBI 63-2
0.12	-	IE2-W.2F 71 G8	(IE1-)K.1F 71 G8	(IE1-)K.OF 63 G8	FBI 63-2
0.12	IE3-W.1F 71 G8	-	-	-	***)
0.18	-	-	(IE1-)K.1F 80 K8	(IE1-)K.OF 71 K8	FBI 71-2
0.18	IE3-W.2F 80 K8	IE2-W.1F 80 K8	-	-	FBI 80-2
0.25	-	-	(IE1-)K.1F 80 G8	(IE1-)K.OF 71 G8	FBI 71-2
0.25	-	IE2-W.1F 80 G8	-	-	FBI 80-2
0.25	IE3-W.1F 80 G8	-	-	-	***)
0.37	-	-	(IE1-)K.1F 90 S8	(IE1-)K.OF 80 K8	FBI 80-2
0.37	IE3-W.2F 90 S8	IE2-W.1F 90 S8	-	-	FBI 90-2
0.55	-	-	(IE1-)K.1F 90 L8	(IE1-)K.OF 80 G8	FBI 80-2
0.55	-	IE2-W.1F 90 L8	-	-	FBI 90-2
0.55	IE3-W.1F 90 L8	-	-	-	***)
0.75	-	-	(IE1-)K.1F 100 L8	(IE1-)K.OF 90 L8	FBI 90-2
0.75	IE3-W.1F 100 LY8	IE2-W.1F 100 L8	-	-	FBI 100-2
1.1	IE3-W.1F 100 LV8	IE2-W.1F 100 LY8	(IE1-)K.1F 100 LX8	(IE1-)K.OF 100 S8	FBI 100-2
1.5	IE3-W.1F 112 M8	IE2-W.1F 112 MV8	(IE1-)K.1F 112 M8	(IE1-)K.OF 100 L8	FBI 100-2
		-	(IE1-)K.1F 112 MX8	-	FBI 100-2
2.2	IE3-W.1F 132 S8	IE2-W.1F 132 S8	(IE1-)K.1F 132 S8T	(IE1-)K.OF 112 M8	FBI 100-2
3.0	IE3-W.1F 132 M8	IE2-W.2F 132 M8	(IE1-)K.1F 132 M8	(IE1-)K.OF 112 MX8	FBI 112-2
4.0	IE3-W.1F 160 M8	IE2-W.1F 160 M8	(IE1-)K.1F 160 M8	(IE1-)K.OF 132 S8	FBI 132-2
5.5	-	-	(IE1-)K.1F 160 MX8	(IE1-)K.OF 132 M8	FBI 132-2
5.5	IE3-W.1F 160 MX8	IE2-W.2F 160 MX8	-	-	FBI 132-2
7.5	-	-	(IE1-)K.1F 160 L8	(IE1-)K.OF 160 S8	FBI 160-2
7.5	IE3-W.1F 160 L8C	IE2-W.1F 160 L8	-	-	FBI 132-2
11.0	-	-	(IE1-)K.1F 180 L8	(IE1-)K.OF 160 M8	FBI 160-2
11.0	IE3-W.1F 180 L8	IE2-W.2F 180 L8	-	-	FBI 180-2
15.0	IE3-W.1F 200 L8	IE2-W.1F 200 L8	(IE1-)K.1F 200 L8	(IE1-)K.OF 180 S8	FBI 200-2
18.5	IE3-W.1F 225 S8	IE2-W.2F 225 S8	(IE1-)K.1F 225 S8	(IE1-)K.OF 180 M8	FBI 200-4
18.5	-	-	(IE1-)K.1F 225 M8	(IE1-)K.OF 200 M8	FBI 200-4
22.0	IE3-W.1F 225 M8	IE2-W.2F 225 M8	-	-	-
30.0	-	-	(IE1-)K.1F 250 M8	(IE1-)K.OF 225 M8	FBI 250-4
30.0	IE3-W.1F 250 M8	IE2-W.2F 250 M8	-	-	FBI 280-25
37.0	-	IE2-W.1F 280 S8	(IE1-)K.1F 280 S8	(IE1-)K.OF 250 S8	FBI 280-25
45.0	-	-	(IE1-)K.1F 280 M8	(IE1-)K.OF 250 M8	FBI 280-25
37.0	IE3-W.1F 280 S8	-	-	-	-
45.0	IE3-W.1F 280 M8	IE2-W.1F 280 M8	-	-	-
55.0	IE3-W.1F 315 S8	IE2-W.1F 315 S8	(IE1-)K.1F 315 S8	(IE1-)K.OF 280 S8	FBI 315-14
75.0	-	IE2-W.1F 315 M8	(IE1-)K.1F 315 M8	(IE1-)K.OF 280 M8	FBI 315-14
75.0	IE3-W.1F 315 M8	-	-	-	FBI 315-23
90.0	-	-	(IE1-)K.1F 315 MX8	(IE1-)K.OF 315 S8	FBI 315-14
90.0	IE3-W.1F 315 MX8	IE2-W.1F 315 MX8	-	-	FBI 315-23
110.0	IE3-W.1F 315 MY8	IE2-W.1F 315 MY8	(IE1-)K.1F 315 MY8	(IE1-)K.OF 315 M8	FBI 315-23
110.0	IE3-W.1F 315 L8	IE2-W.1F 315 L8	(IE1-)K.1F 315 L8	(IE1-)K.OF 315 L8	FBI 315-23
160.0	-	IE2-W.1F 315 LX8	(IE1-)K.1F 315 LX8	(IE1-)K.OF 315 LX8	FBI 315-23
132.0	IE3-W.1F 355 MY8	IE2-W.2F 355 MY8	(IE1-)K.2F 355 MY8	-	FBI 355-26
132.0	IE3-W.1F 355 M8	IE2-W.2F 355 M8	(IE1-)K.2F 355 M8	-	FBI 355-26
160.0	IE3-W.2F 355 MX8	IE2-W.2F 355 MX8	(IE1-)K.2F 355 MX8	-	FBI 355-26
200.0	IE3-W.2F 355 L8	IE2-W.2F 355 LY8	(IE1-)K.2F 355 LY8	-	FBI 355-26

Corresponding basic version plus fan

Motors with forced ventilation must always be provided with thermal motor protection.

Observe catalogue data regarding outputs in converter-fed operation.

In accordance with Regulation (EC) No. 640/2009, motors in 2-, 4- and 6-pole versions for outputs from 0.75 to 355 kW may only be brought onto the market if they do not fall within the scope of applicability of the regulation on account of the operating conditions specified by the customer.

(IE1-) can be supplied with and without marking of IE classification

***) upon request

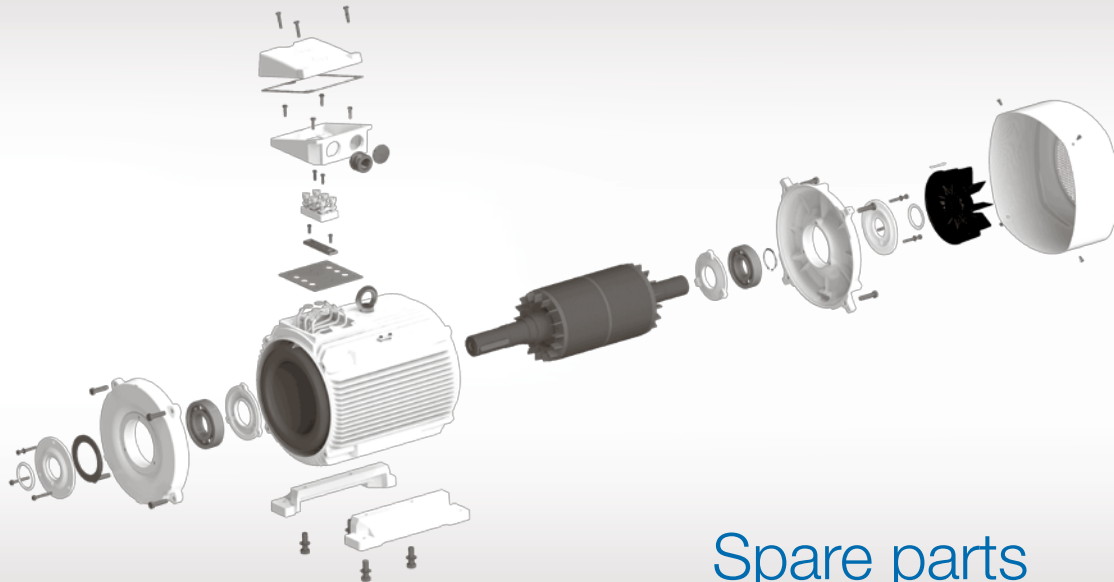

Spare parts

Contents

General notes _____	15/2
Overview of spare parts: Three-phase asynchronous motors with squirrel-cage rotor _____	15/3
Exploded view (IE.-)K2.R 56 bis (IE.-)132 T	
Exploded view K1.R, (IE1-)K2.R, (IE1-)K.2R 112 to 355, IE2-W.1R, IE3-W41R	
Overview of spare parts: Three-phase transnorm motors with squirrel-cage rotor _____	15/6
Exploded view W42R 355 to 400	
Overview of spare parts: Three-phase asynchronous motors with slip-ring rotor _____	15/8
Exploded view S..R 132 bis 315 M, S..H 132 to 315 M	
SPR, SPH, S10R, S10H	
Exploded view S11R/S11H 315 MX, MY, LX, LY	
Overview of spare parts: Three-phase roller table motors _____	15/11
Exploded view ARB 22 to 65	
Exploded view ARC 112 to 400	
Exploded view AR. 112 to 400	

General notes

Delivery promise regarding replacement motors and spare parts

Spare parts remain available for five years after discontinuation of a series. Beyond this period of five years, VEM continues to provide technical information on both the complete motor and its components, and endeavours to supply requested spare parts (subject to availability); if spare parts are no longer available, corresponding manufacturing documents can be provided.

Information required when ordering spare parts

Orders for spare parts must include the following information:

- Motor designation and motor number (serial number)
- Designation of the spare part
- Year of manufacture

Overview of spare parts: Three-phase asynchronous motors with squirrel-cage rotor

Item no.	Designation
1.01	End shield, D-end
1.02	Bearing cover, D-end, outside
1.03	Bearing cover, D-end, inside
1.04	Disc spring/wave spring, D-end, not with roller bearings
1.05	Antifriction bearing, D-end
1.06	V-ring, D-end
1.07	Flange end shield
1.08	Felt ring, D-end
2.01	End shield, N-end
2.02	Bearing cover, N-end, outside
2.03	Bearing cover, N-end, inside
2.04	Antifriction bearing, N-end
2.05	V-ring, N-end
2.06	Wave spring, N-end (or D-end)
2.08	Felt ring, N-end
3.01	Motor feet (pair)
3.02	Fan
3.03	Fan cowl, plastic
3.04	Fan cowl, sheet steel
3.05	Fan cowl with canopy
3.06	Eye bolt
4.01/4.02	Terminal box cover
4.03/4.04	Gasket, terminal box cover
4.05/4.06	Terminal box base
4.07	Gasket, terminal box base
4.08	Terminal plate
4.09	Cable gland
4.10	Screw plug
4.11	Cable gland for thermal winding protection
4.12	Terminal for thermal winding protection
4.13	Clamp
4.14	Sealing plugs
4.15	Adapter plate
4.16	Flat terminal box
4.17	Standard parts bag
5.01	Rotor, complete
5.02	Shaft key
6.01	Thrower ring, D-end
6.02	Thrower ring, N-end
6.03	Labyrinth gland, D- and N-end
6.04	Guide disc, D-end
6.05	Guide disc, N-end

Three-phase asynchronous motors with squirrel-cage rotor, (IE-)K2.R 56 to (IE-)132 T

(Example; delivered version may differ in certain details)

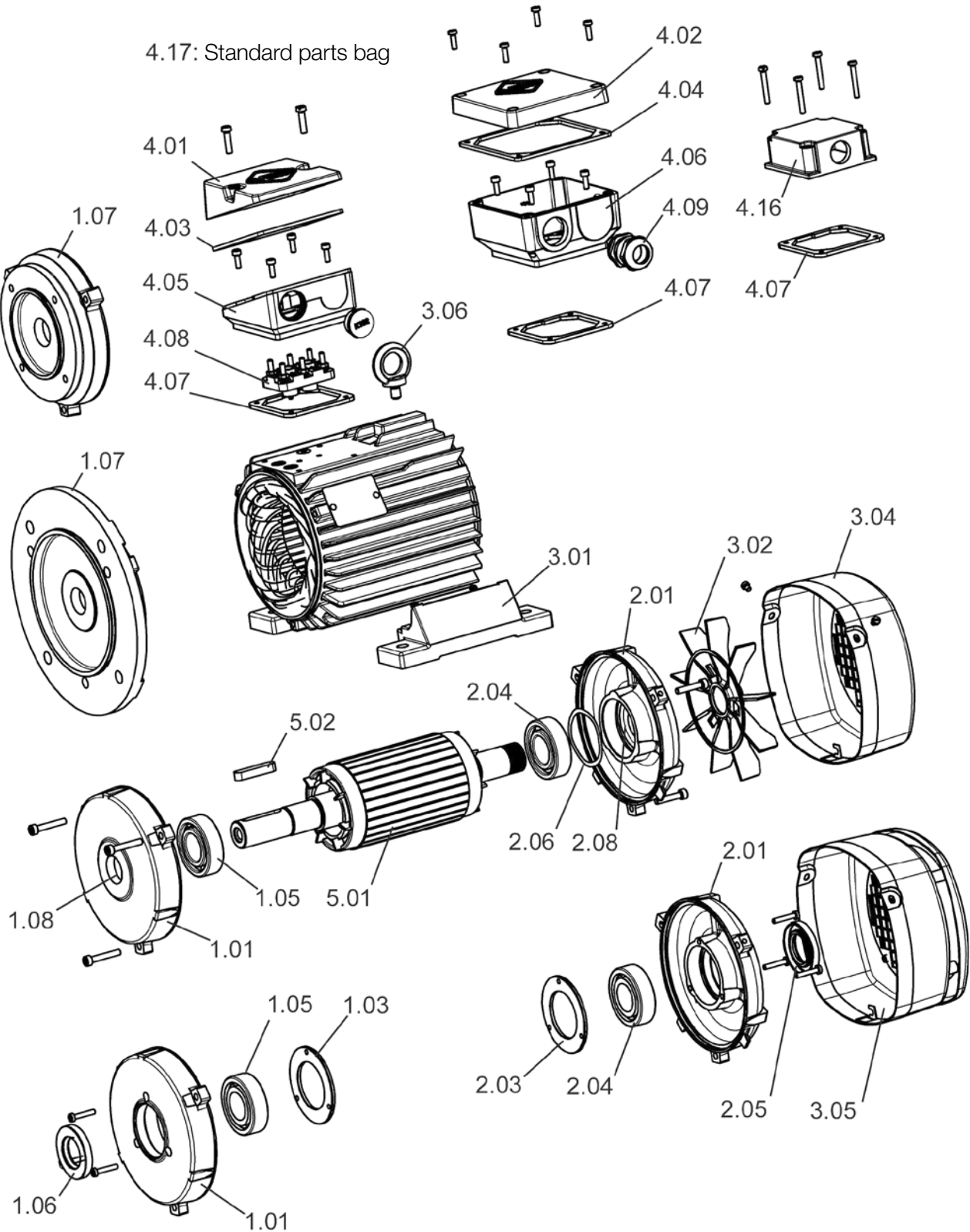

Three-phase asynchronous motors with squirrel-cage rotor, K1.R, (IE1-)K2.R, (IE1-)K.2R 112 to 355
IE2-W.1R, IE3-W41R

(Example; delivered version may differ in certain details)

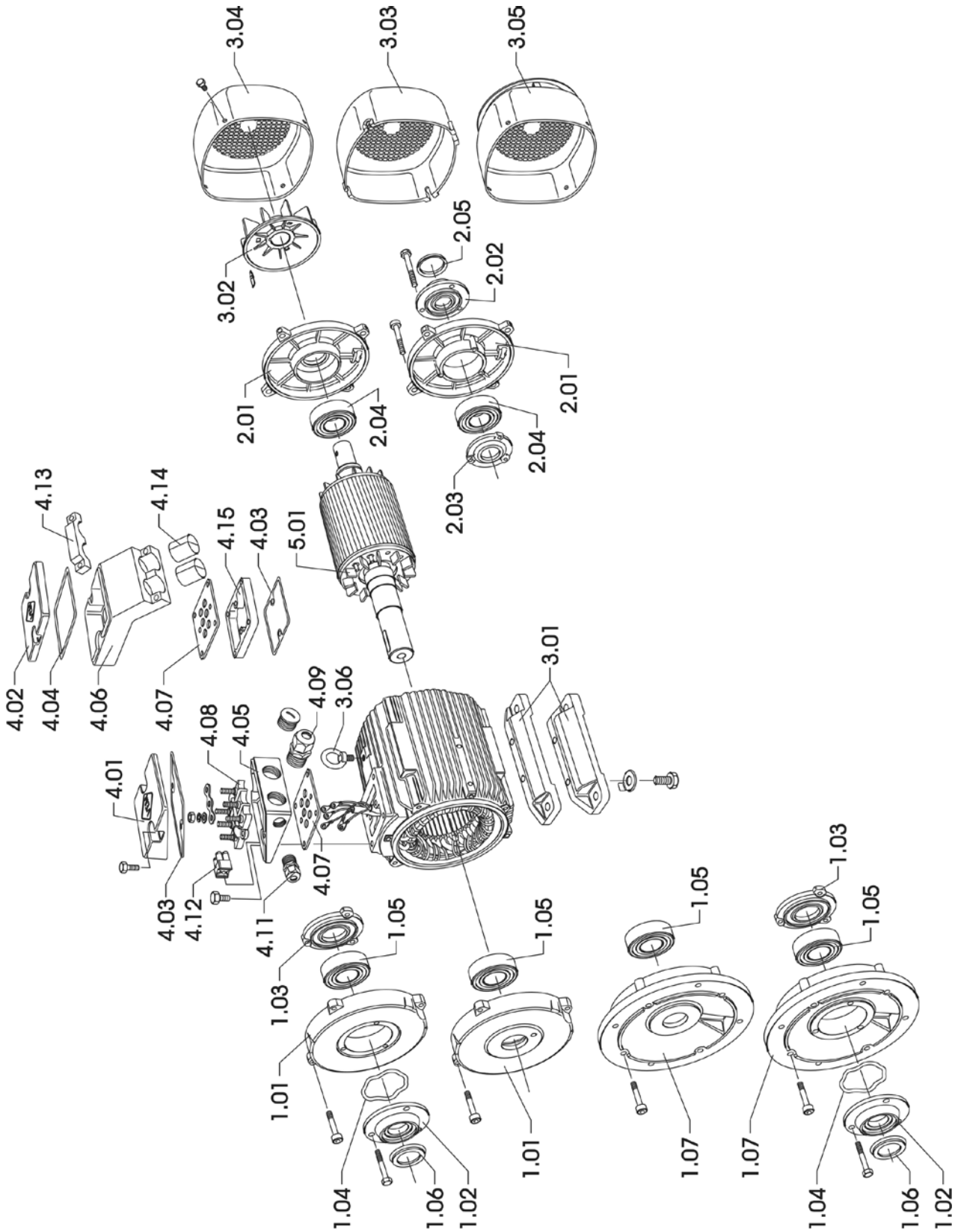

Overview of spare parts: Three-phase transnorm motors
with squirrel-cage rotor
Basic version W42R 355 bis 400

Item no.	Designation
1.01	End shield, D-end
1.02	Bearing cover, D-end, outside
1.03	Guide disc, D-end
1.04	Pressure springs
1.05	Thrower ring, D-end
1.06	Bearing cover, D-end, inside
1.07	Antifriction bearing, D-end
1.08	Sealing ring, D-end
1.09	Flange end shield
2.01	Housing with winding
2.02	Eye bolt
3.01	End shield, N-end
3.02	Bearing cover, N-end, outside
3.03	Guide disc, N-end
3.04	Thrower ring, N-end
3.05	Bearing cover, N-end, inside
3.06	Antifriction bearing, N-end
3.07	Sealing ring, N-end
4.01	Fan
4.02	Fan cowl
4.03	Internal fan
4.04	Rotor, complete
4.05	Shaft key
5.01	Terminal box, motor type W4..
5.02	Terminal box cover
5.03	Gasket, terminal box cover
5.04	Terminal box base
5.05	Gasket, terminal box base
5.06	Terminal plate
5.06	Adapter flange with gasket
7.01	Transponder

Three-phase transnorm motor with squirrel-cage rotor, basic version W42R 355 to 400

(Example; delivered version may differ in certain details)

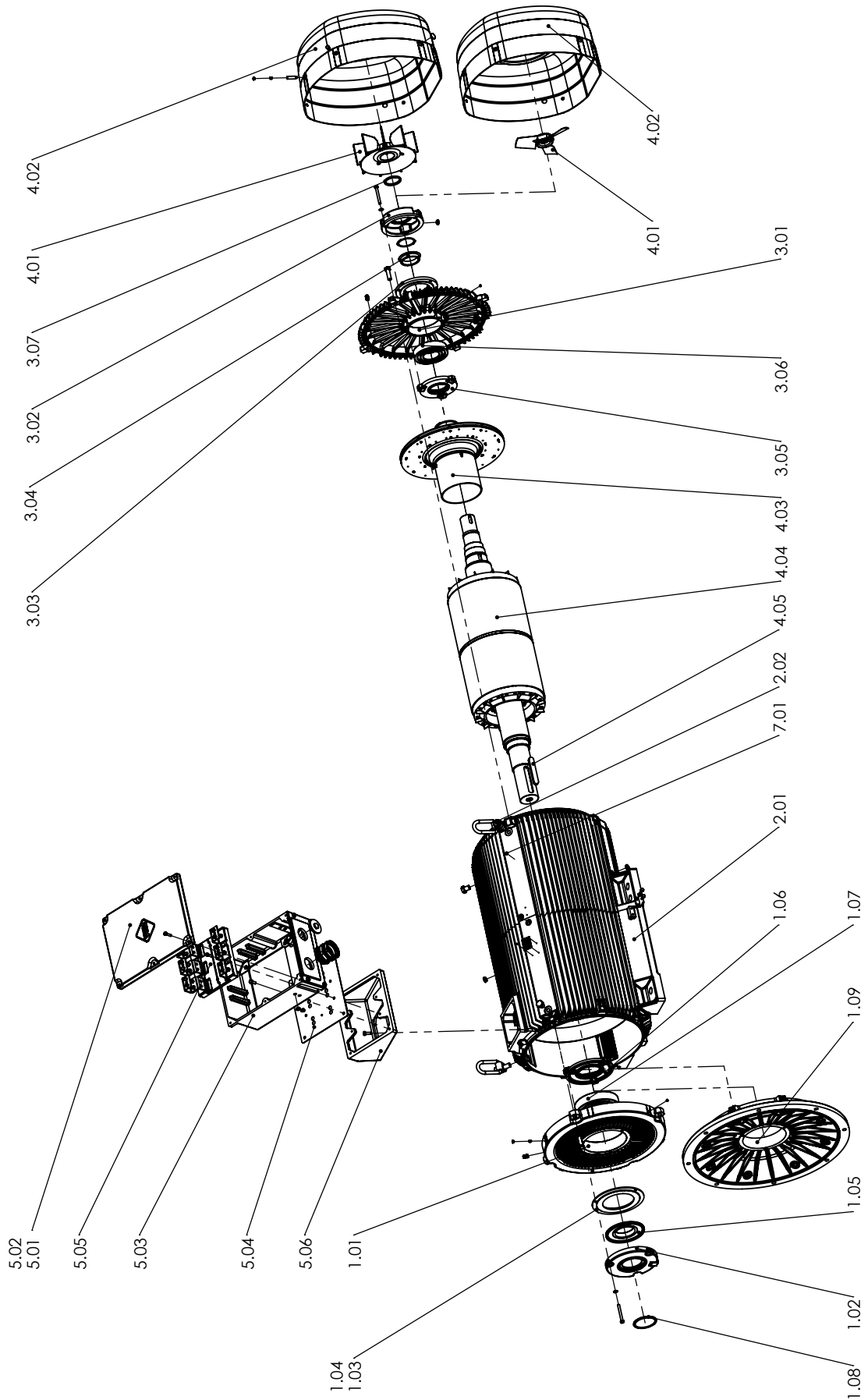

Overview of spare parts: Three-phase asynchronous motors with slip-ring rotor

Item no.	Designation
1.01	End shield D-end
1.02	Bearing cover, D-end, outside
1.03	Bearing cover, D-end, inside
1.04	Disc spring/wave spring, D-end, not with roller bearings
1.05	Antifriction bearing, D-end
1.06	V-ring, D-end
1.07	Flange end shield
1.08	Felt ring, D-end
2.01	End shield, N-end
2.02	Bearing cover, N-end, outside
2.03	Bearing cover, N-end, inside
2.04	Antifriction bearing, N-end
2.05	V-ring, N-end
2.06	Wave spring
2.08	Felt ring, N-end
3.01	Motor feet (pair)
3.02	Fan
3.03	Fan cowl, plastic
3.04	Fan cowl, sheet steel
3.05	Fan cowl with canopy
3.06	Eye bolt
4.01/4.02	Terminal box cover
4.03/4.04	Gasket, terminal box cover
4.05/4.06	Terminal box base
4.07	Gasket, terminal box base
4.08	Terminal plate
4.09	Cable gland
4.10	Screw plug
4.11	Cable gland for thermal winding protection
4.12	Terminal for thermal winding protection
4.13	Clamp
4.14	Sealing plugs
4.15	Adapter plate
4.16	Flat terminal box
4.17	Standard parts bag
5.01	Rotor, complete
6.01	Thrower ring, D-end
6.02	Thrower ring, N-end
6.03	Labyrinth gland, D- and N-end
6.04	Guide disc, D-end
6.05	Guide disc, N-end
7.01	Slip-ring rotor with slip rings
8.01	Brush holder
8.02	Brush carrier plate with brush pin
8.03	Protective cover for slip ring compartment
8.04	Gasket for protective cover
8.05	Cover for fan cowl
9.01	Terminal box cover for rotor terminal box
9.02	Gasket, terminal box cover for rotor terminal box
9.03	Terminal plate for rotor connection
9.04	Terminal box base for rotor connection
9.05	Cable gland for rotor connection
9.06	Adapter flange for rotor terminal box
9.07	Screw plug for rotor connection

Three-phase asynchronous motor with slip-ring rotor, basic version
SPER 132 – 250/S11R 280 – 315 M, SPEH 132 – 250/S11R 250 – 315 M, SPR, SPH

(Example; delivered version may differ in certain details)

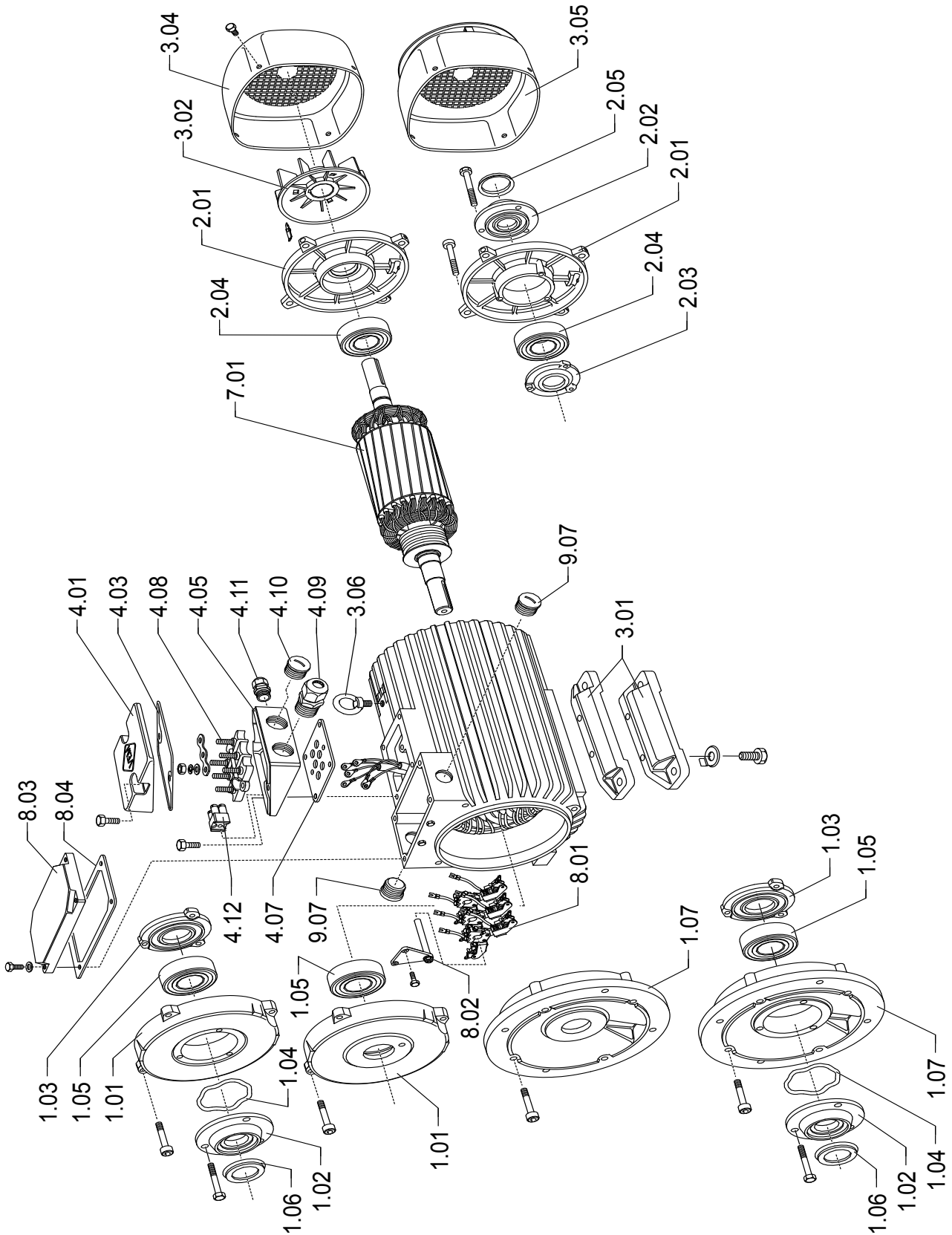

**Three-phase asynchronous motor with slip-ring rotor, basic version
S11R 315 MX, MY, LX, LY / S11H 315 MX, MY, LX, LY**

(Example; delivered version may differ in certain details)

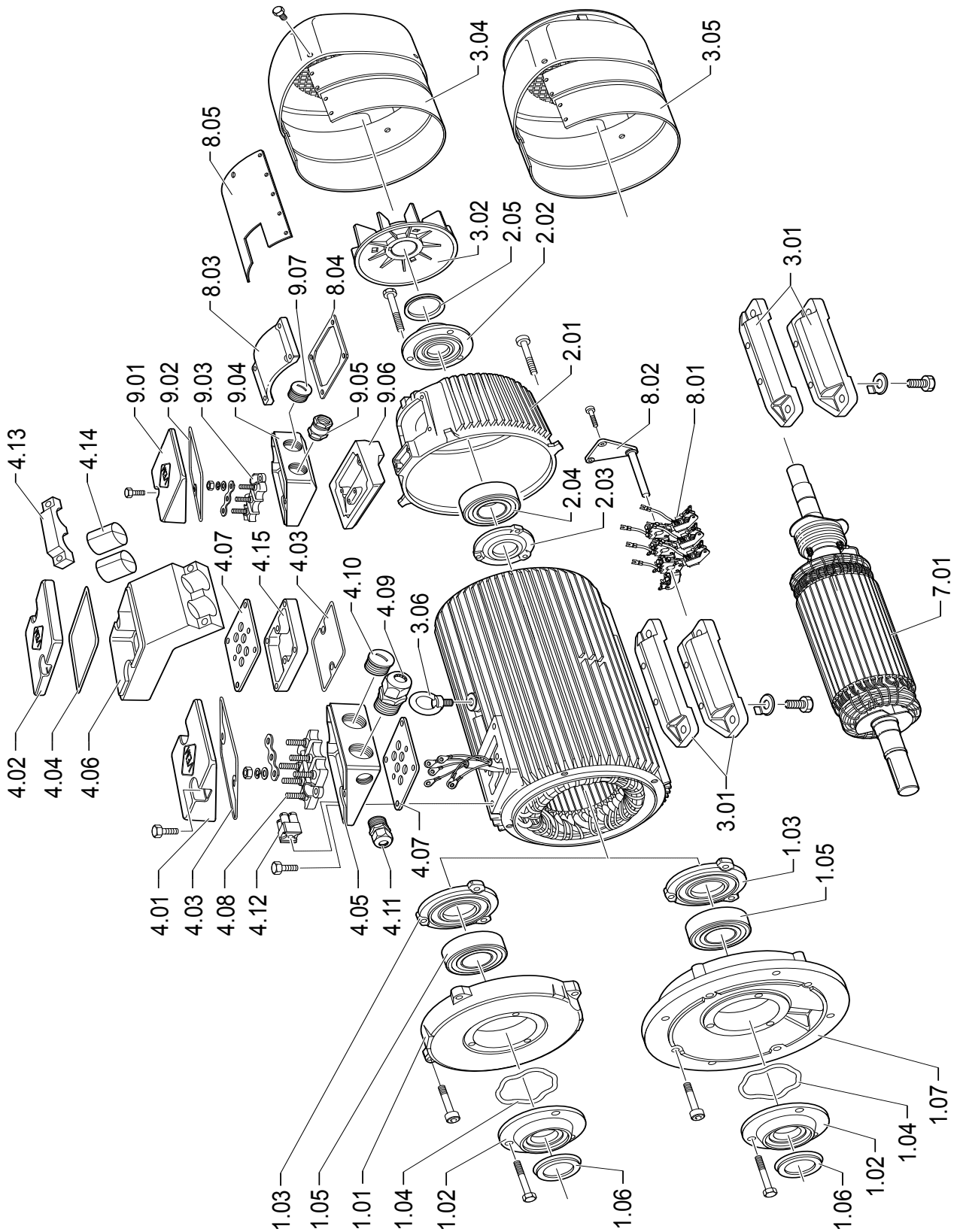

Overview of spare parts: Three-phase roller table motors

Item no.	Designation
1.01	End shield D-end
1.02	Bearing cover, D-end, outside
1.03	Bearing cover, D-end, inside
1.04	Disc spring/wave spring, D-end, not with roller bearings
1.05	Antifriction bearing, D-end
1.06-1	V-ring, D-end
1.06-2	γ-ring, D-end
1.07	Flange end shield
1.08-1	Radial shaft seal 1, D-end
1.08-2	Radial shaft seal 2, D-end
1.09	Liner, D-end
2.01	End shield, N-end
2.02	Bearing cover, N-end, outside
2.03	Bearing cover, N-end, inside
2.04	Antifriction bearing, N-end
2.05	V-ring, N-end
2.06	Wave spring, N-end (or D-end)
3.01	Motor feet (pair)
3.02	Fan
3.03	Fan cowl, plastic
3.04	Fan cowl, sheet steel
3.05	Fan cowl with canopy
3.06	Eye bolt
4.01/4.02	Terminal box cover
4.03/4.04	Gasket, terminal box cover
4.05/4.06	Terminal box base
4.07	Gasket, terminal box base
4.08	Terminal plate
4.09	Cable gland
4.10	Screw plug
4.11	Cable gland for thermal winding protection
4.12	Terminal for thermal winding protection
4.13	Clamp
4.14	Sealing plugs
4.15	Adapter plate
4.16	Flat terminal box
4.17	Standard parts bag
5.01	Rotor, complete
5.02	Heat sink, D-end
5.03	Heat sink, N-end
6.01	Thrower ring, D-end
6.02	Thrower ring, N-end
6.03	Labyrinth gland, D- und N-end
6.04	Guide disc, D-end
6.05	Guide disc, N-end
6.06	Cover, D-end
6.07	Cover, N-end
7.01	Speed sensor or tacho
7.02	Brake
8.01	Gearbox

Three-phase roller table motor, basic version ARB 22–65

(Example for construction type IM B5, further types (IM B3 und IM B35) possible; delivered version may differ in certain details)

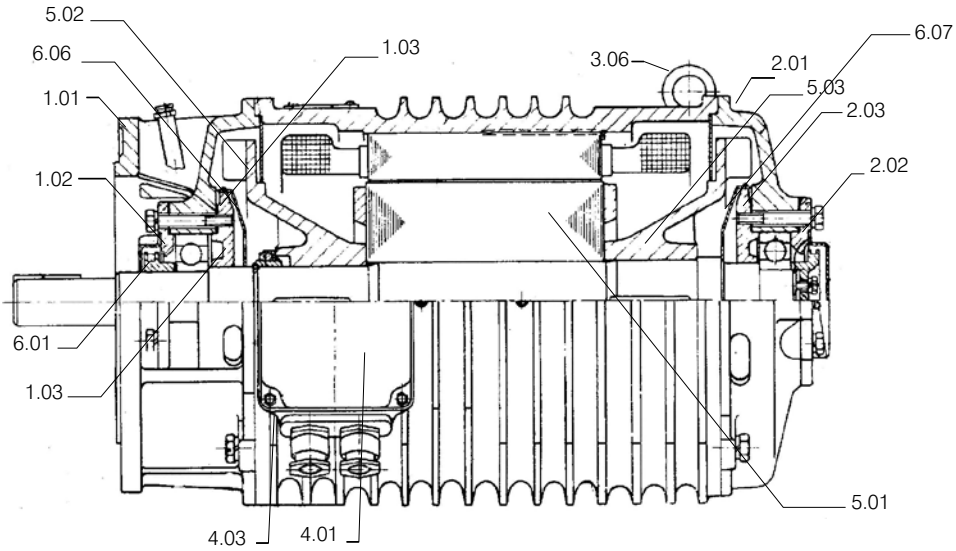

Three-phase roller table motor, basic version ARC 112-400

(Example; delivered version may differ in certain details)

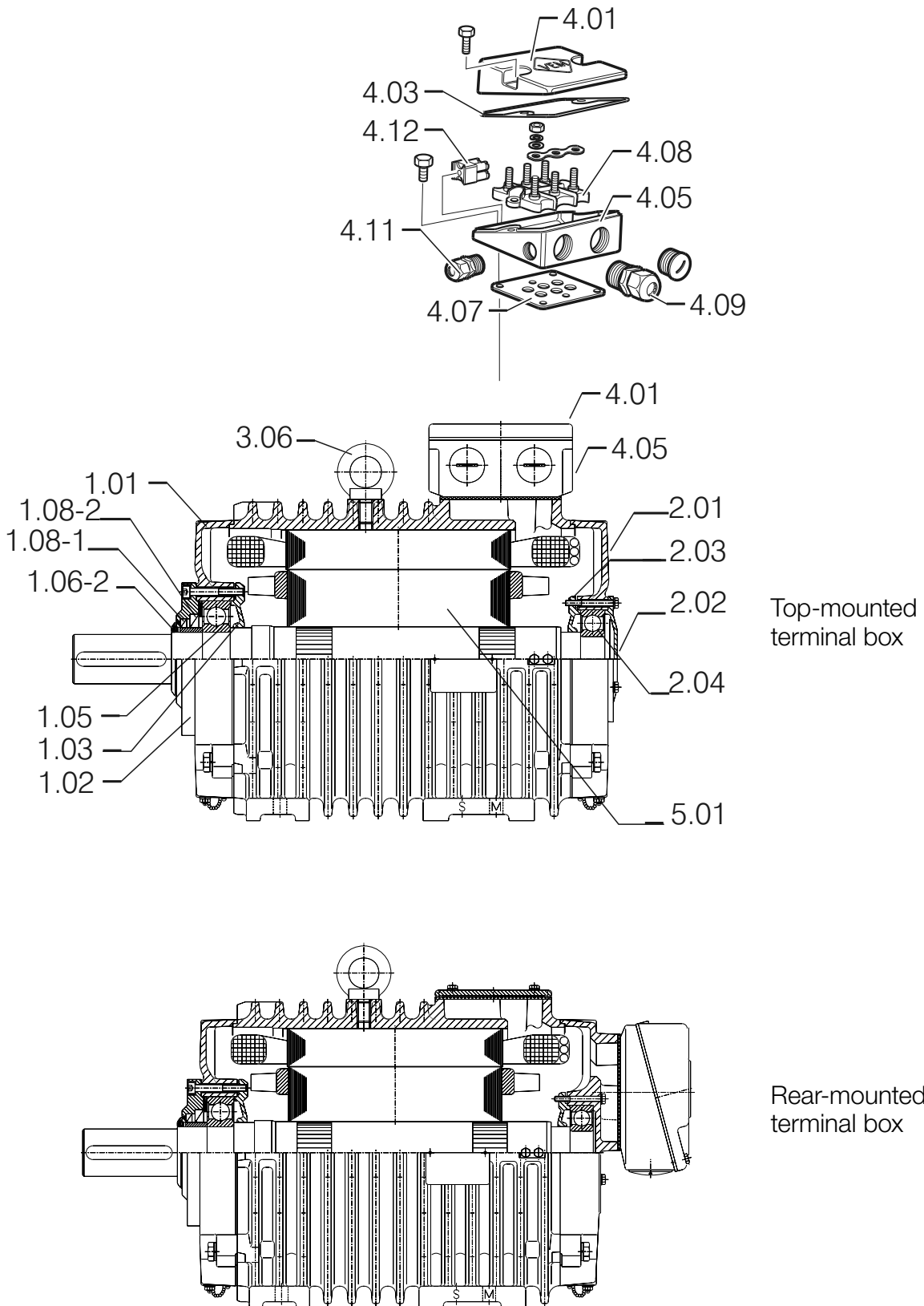

Top-mounted terminal box

Rear-mounted terminal box

Three-phase roller table motor, special version AR. 112–400
Geared motor version
Built-on speed sensor or tacho, brake, speed sensor or tacho

(Example; delivered version may differ in certain details)

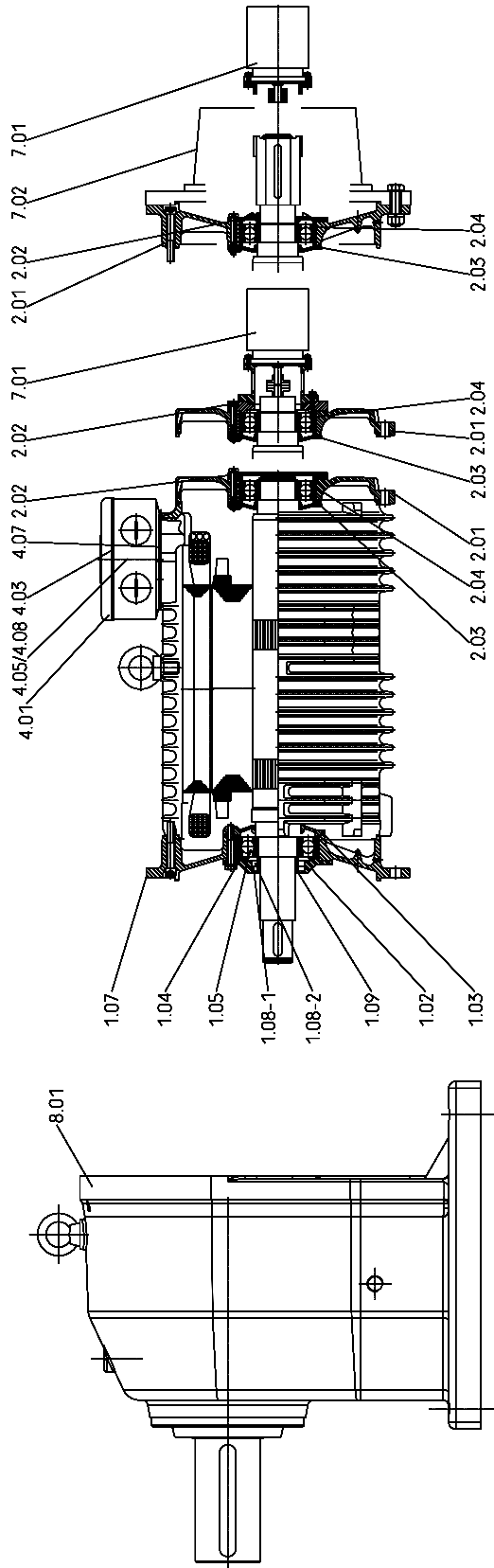



Annex

Contents

Parameters, conversions and
formulae for technical units of measurement _____ 16/2

General information to aid configuration _____ 16/4

VEM-Product Range _____ 16/28

Parameters, conversions and formulae for technical units of measurement

in SI units of measurement (Système Internationale d'Unité)

Power

1 kW = 1.36 h.p. = 102 kpm/s = 1,000 Nm/s
1 h.p. = 0.736 kW = 75 kpm/s = 736 Nm/s

Work

1 kWh = 3.6×10^6 J = 3.6×10^6 Nm
1 Nm = 0.367 x 106 kpm
1 Ws = 1 J = 1 Nm = 0.102 kpm

Force

1 N = 0.102 kp
1 kp = 9.81 N

Torque

1 Nm = 0.102 kpm = 1 Ws
1 kpm = 9.81 Nm = 9.81 Ws

Pressure

1 Pa = 1 N/m²
1 bar = 10⁵ Pa
1 mm water gauge = 9.81 Pa

Temperature/temperature differences

1 deg = 1 K = 1 °C

Moment of inertia

1 kgm² = 1 Ws³ = 1 Nms² = 0.102 kpm²

Characteristic drive parameters

P_1 ... power input [kW]
 P_2 ... power output [kW]
 P_B ... rated power [kW]
 P ... effective power [kW]
 S ... apparent power [kVA]
 Q ... reactive power [kvar]
 U ... voltage [V]
 U_U ... lower voltage limit [V]
 U_B ... rated voltage [V]
 U_O ... upper voltage limit [V]
 I_B ... rated [nominal] current [A]
 f_B ... rated frequency
 $\cos\varphi$... power factor [-]
 $\cos\varphi_B$... rated power factor [-]
 η ... efficiency [%]
 η_B ... rated efficiency [%]
 n_s ... synchronous speed [rpm]
 n_B ... rated [nominal] speed [rpm]
 M_B ... rated [nominal] torque [Nm]
 M_A ... starting torque [Nm]
 M_S ... pull-up torque [Nm]
 M_K ... pull-out torque [Nm]
 I_A ... starting current [A]
 s_B ... rated slip [%]
 J ... motor moment of inertia [kgm²]

Equivalent circuit data

R_{1w} ... stator winding equivalent resistance at operating temperature in ohms
[at 120 °C winding temperature]
 R_{2w} ... rotor winding equivalent resistance at operating temperature, referred to stator side, in ohms
[at 120 °C winding temperature]
 R_{Fe} ... ohmic equivalent resistance
[also iron equivalent resistance]
 X_{1s} ... stator winding leakage reactance in ohms
 X_{2s} ... rotor winding leakage reactance in ohms, referred to stator side
 X_{1h} ... stator winding main reactance

Specific quantities

M_A/M_B ... relative starting torque [-]
 M_S/M_B ... relative pull-up torque [-]
 M_K/M_B ... relative pull-out torque [-]
 I_A/I_B ... relative starting current [-]

Drive engineering formulae

Power input

$$P_1 = U \times I \times \cos\varphi \times \sqrt{3} \times$$

Power output

$$P_2 = P_1 \times \eta / 100 \text{ [kW]}$$

Power loss

$$P_V = P_1 - P_2 \text{ [kW]}$$

Effective power

$$P = \frac{P_2 \times 100}{\eta} \text{ [kW]}$$

Apparent power

$$S = \frac{U \times I \times \sqrt{3}}{1000} \text{ [kVA]} \text{ or } S = \frac{100 \times P_2}{\eta \times \cos\varphi} \text{ [kVA]}$$

Reactive power

$$Q = \frac{P_1 \times \tan\varphi \times 100}{\eta} \text{ [kvar]}$$

Current consumption

$$I = \frac{P_w \times 1000}{U \times \cos\varphi \times \sqrt{3}} \text{ [A]} \text{ or } I = \frac{P_2 \times 1000 \times 100}{U \times \eta \times \cos\varphi \times \sqrt{3}} \text{ [A]}$$

Rated slip

$$s_B = \frac{n_s - n_B}{n_s} \times 100 \text{ [%]}$$

Rated torque

$$M_B = 9.55 \times P_B \times \frac{1000}{n_B} \text{ [Nm]}$$

Power demand of selected machines

Lifting movement

$$P = \frac{F \times v}{\eta} \times 10^{-3} \text{ [kW]}$$

Rotating movement

$$P = \frac{M \times n}{9550 \times \eta} \text{ [kW]}$$

Fan drive

$$P = \frac{V \times p}{\eta} \times 10^{-3} \text{ [kW]}$$

Pump drive

$$P = \frac{V \times p}{\eta} \times 10^{-3} \text{ [kW]}$$

P ... power [kW]

F ... force [N]

v ... velocity [m/s]

η ... efficiency

M... torque [Nm]

n ... speed [rpm]

V ... delivery rate [m³/s]

p ... total counterpressure to be overcome [N/m²]

Torques

Conversion of torques for step-down and step-up gearing

$$M_2 = \frac{M_1 \times n_1}{n_2}$$

n_1 ... motor speed [rpm]

M_1 ... motor torque [Nm]

n_2 ... working speed [rpm]

M_2 ... torque at n_2 [Nm]

Moment of inertia

related to rotative moment

$$J = \frac{GD^2}{4}$$

J ... moment of inertia [kgm²]

GD² ... rotative moment [kpm²]

Conversion of moments of inertia to another speed for step-down or step-up gearing

$$J_2 = J_1 \times \left(\frac{n_1}{n_2} \right)^2$$

n_1 ... motor speed

J_1 ... moment of inertia at n_1

n_2 ... working speed

J_2 ... moment of inertia at n_2

Inertia factor

$$F_I = \frac{J_{\text{mot}} + J_{\text{fremd}}}{J_{\text{mot}}}$$

J_{mot} ... moment of inertia of motor [kgm²]

J_{fremd} ... moment of inertia of machine [kgm²]

$$J_{\text{ges}} = J_{\text{fremd}} + J_{\text{mot}}$$

Starting time

$$t_A \approx \frac{J_{\text{ges}} \cdot n_B}{9,55 \times M_{\text{b,m}}} \text{ in [s]}$$

J_{ges} = total moment of inertia to be accelerated in kgm²

n_B = rated speed in rpm

$M_{\text{b,m}}$ = moment of acceleration in Nm

Formulae from acoustics

Sound pressure level

$$L_p = 20 \log \frac{p}{p_0} \text{ [dB]}$$

Reference sound pressure

$$p_0 = 2 \times 10^{-5} \text{ [Pa]}$$

Sound power level

$$L_w = 10 \log \frac{P}{P_0} = L_p + L_s \text{ [dB]}$$

Reference sound power

$$P_0 = 10^{-12} \text{ [W]}$$

Measuring-surface level

$$L_s = 10 \log \frac{S}{S_0} \text{ [dB]}$$

Reference surface

$$S_0 = 1 \text{ m}^2$$

L_p ... sound pressure level [dB]

P ... sound power [Pa]

P_0 ... reference sound pressure [Pa]

L_w ... sound power level [dB]

P ... sound power [W]

P_0 ... reference sound power [W]

L_s ... measuring-surface level [dB]

S ... measuring surface [m²]

S_0 ... reference surface [m²]

General information to aid configuration

1. Torque behaviour and starting current

Fig. 1 shows the characteristic behaviour of torque/current in asynchronous machines for all areas of practical interest.

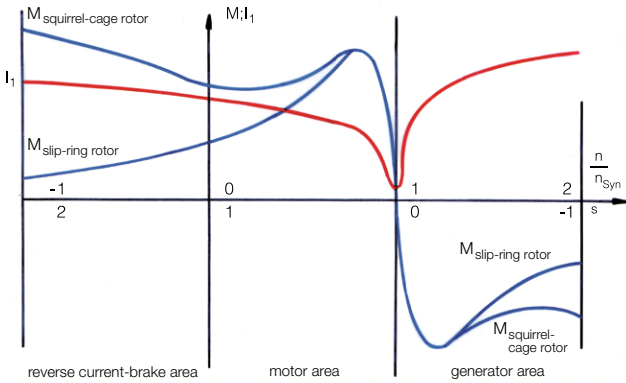

M = Torque
 I₁ = Stator current
 n/n_{Syn} = Ratio speed/synchronous speed
 s = Slip

Figure 1: Characteristic behaviour of torque/current in three-phase asynchronous motors

The torque characteristics of squirrel-cage and slip-ring motors differ significantly in the range $1.2 < n/n_s < 0.8$ due to the specific current displacement effect attributable to the cage design of squirrel-cage motors. By contrast, the characteristic current behaviour of the two machine types is practically identical.

These curves identify characteristic parameters for the motor range of three-phase motors. These parameters are explained in Fig. 2 using the basic characteristic of a squirrel-cage motor.

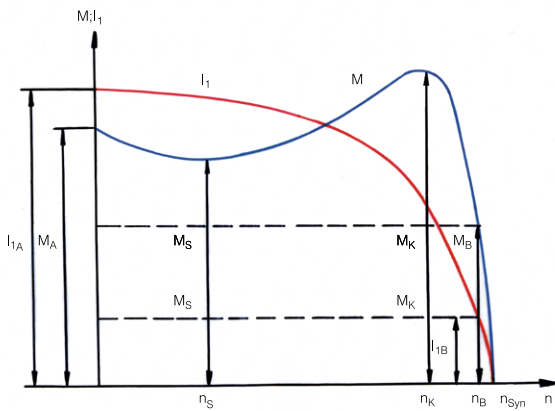

Figure 2: Characteristic behaviour of torque/current in a squirrel-cage motor

- I_A = Starting current**
 (also known as short-circuit current).
 Max. current drawn by a motor at standstill when supplied with rated voltage/rated frequency in all possible rotor positions after transient reactions have passed.
- M_A = Starting torque**
 (also known as stalled torque).
 Smallest torque occurring on the shaft end when a motor is supplied with rated voltage/rated frequency in all possible rotor positions after transient reactions have passed.
- M_S = Pull-up torque** (also known as ramp-up torque).
 Smallest torque occurring on the shaft end of a motor supplied with rated voltage/rated frequency over the range between standstill and sweep speed when speed changes slowly.
- n_S = Pull-up speed** related to the pull-up torque
- M_K = Pull-out torque**
 First torque maximum on the shaft end of a machine supplied with rated voltage/rated frequency when speed is slowly reduced starting from synchronous speed.
- M_B = Rated torque**
- n_B = Rated speed**
- n_{Syn} = Synchronous speed**

It is standard practice to relate torque and current quantities to the design data of a motor:

Relative starting current $i_A = \frac{I_A}{I_B}$

Relative starting torque $m_A = \frac{M_A}{M_B}$

Relative pull-up torque $m_S = \frac{M_S}{M_B}$

Relative pull-out torque $m_K = \frac{M_K}{M_B}$

2. Operating characteristics

This is understood to designate the behaviour of essential operating values of a motor over the stable working range between no-load running and outputs in the area of the rated output. These values are normally plotted as a function of output (Fig. 3).

Operating characteristics are an important aid for the evaluation of drives, particularly with regard to partial load and overload behaviour. Partial load values for the power factor $\cos\varphi$ and efficiency η of standard motors can be found in the tables of motor selection data. All other operating values, in particular power output and thus actual load, are easy to determine by measuring the absorbed power or stator current. Operating characteristics for standard motors can be found in our electronic catalogue VEM-KAT; they can also be requested directly from the motor manufacturer.

Essential operating values such as efficiency η and power factor $\cos\varphi$ have been defined in the course of motor design such that an optimum is achieved at rated output P_{2B} .

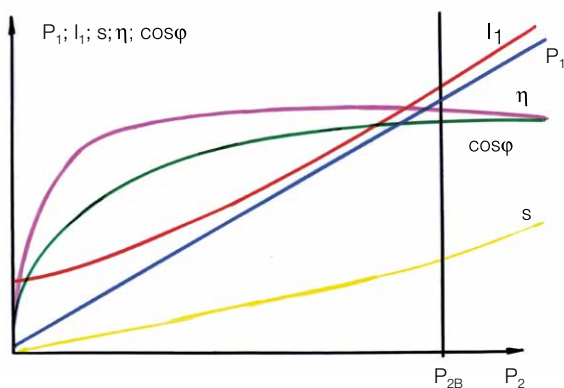

Figure 3: Operating characteristics of an asynchronous motor

Minimum values for the relative pull-out, pull-up and starting torques for three-phase motors are specified in IEC/EN 60034-12.

The actual characteristics achieved by modern standard motors generally far exceed these minimum requirements. Current and torque characteristic data for squirrel-cage motors are given in the technical data, making it possible to predetermine the speed-torque characteristic with sufficient accuracy, for example to judge the starting behaviour of squirrel-cage motors.

While efficiency varies only slightly over a comparatively wide range, a major drop in the power factor must be expected in the partial load range. Figs. 4 and 5 permit corresponding estimations for most cases.

Rated values for operating data can be found in the corresponding technical documentation or else on the rating plate of the motor concerned. Where the efficiency of a motor is not specified on the rating plate, it can be calculated from the standard data as follows:

$$\eta_B = \frac{P_{2B}}{\sqrt{3} \cdot U_{1B} \cdot I_{1B} \cdot \cos\varphi_B} \cdot 100 \%$$

Most operating characteristics specify the slip s , enabling the corresponding speed to be determined as follows:

$$n = n_{Syn} (1 - s)$$

n_{Syn} = synchronous speed

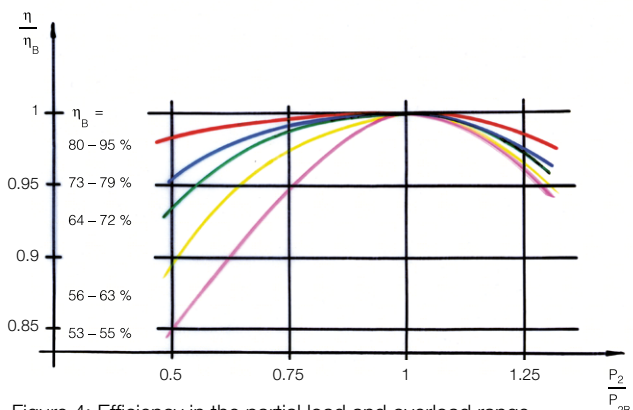

Figure 4: Efficiency in the partial load and overload range

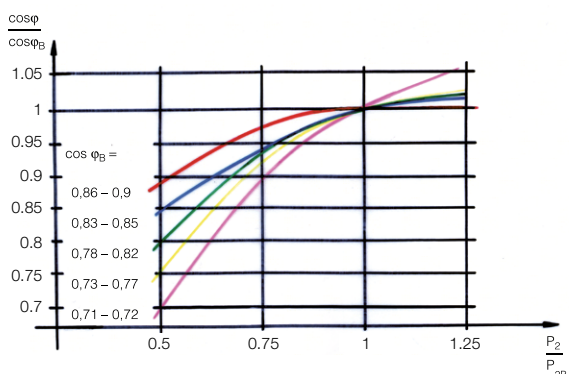

Figure 5: Power factors in the partial load and overload range

3. Pole-changing motors

The mechanical construction of a pole-changing motor corresponds to that of a squirrel-cage motor in its basic version, which means that mounting and assembly dimensions are identical, with the exception of a few versions with three or four speeds, where a larger terminal box is required. In such cases, the dimensions HD (p) and O (r) deviate from the dimensioned drawings for the basic versions.

Pole changing is achieved by appropriate configuration of the stator windings. For motors with two speeds at a ratio of 1:2, a Dahlander winding is preferred. Where other ratios between the two speeds are required, the motor possesses two separate windings. Two windings, one or both of which are designed with Dahlander connection, are needed where a motor has three or more speeds.

Pole-changing motors are designed for direct starting (lowest speed), and higher speeds should normally be reached by going through the lower stages first. For switching back (braking), see the notes given in section 10.

Connecting terminals are designated in accordance with IEC/EN 60034-8.

Examples of terminal connection plans are shown in Fig. 6.

With regard to the individual numbers of poles and speeds, the notes given in section 1 apply equally to pole changing motors, with the exception of the specified minimum values for relative pull-out, pull-up and starting torque, which are expressly exempted from IEC/EN 60034-12.

Pole-changing squirrel-cage motors are suitable for use as machine tool drives, for example. They are able to replace multiple-speed gearboxes or else considerably widen their speed control ranges.

In many drives, they are also a suitable substitute for slipping motors, the advantage being better efficiency at lower speeds. Pole-changing motors combine the basic robustness of squirrel-cage motors with stepped speed control. That is not least the reason why they are used in many special drive applications:

- Lifting gear motors (exact positioning to floor height at low speed, travel at high speed)
- Slide rest adjustment (approach at low speed, retraction at high speed)
- Planers (working pass at low speed, reversing at high speed)
- Pumps, fans, textile machines and similar drives

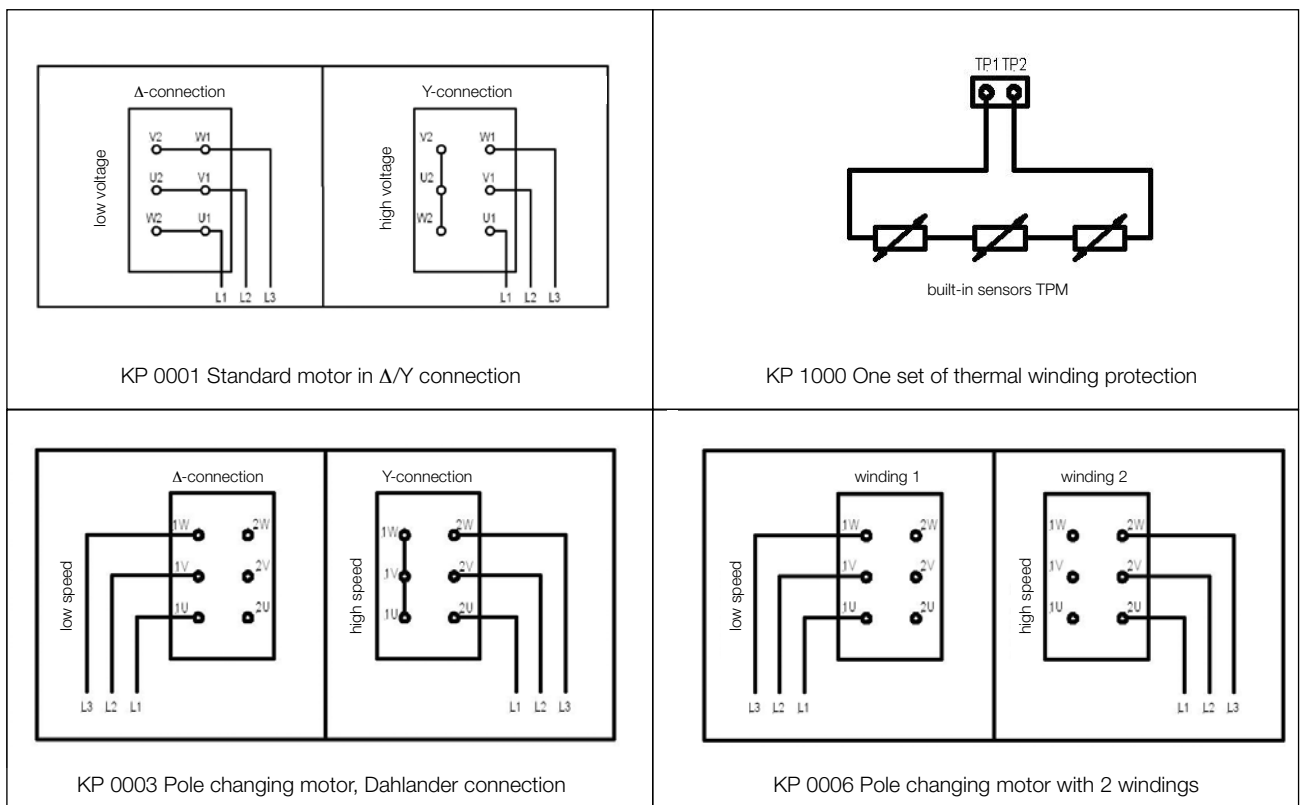

Figure 6: Terminal connection plans (examples)

On an ever growing scale, squirrel-cage motors are fed through a frequency converter for speed control and/or variable-speed operation. Through appropriate programming of the frequency converter, the drive can be configured and adapted optimally for any required speed.

The operating point of a pump or fan drive, for example, can be adjusted to the required flow rate. Compared to volume flow control via regulators or pole-changing motors, this achieves considerable energy savings.

4. Multi-voltage motors

Multi-voltage motors can be operated with the same rated output on mains supplies with different voltages. Their mechanical construction corresponds to that of motors in the basic version, which means that mounting and assembly dimensions are identical, with the exception of a few motor sizes which use larger terminal boxes because they require terminal bases with 9 or 12 terminal studs. In these cases, the dimensions HD (p) and O (r) deviate from the dimensioned drawings of the basic versions.

Voltage switching is achieved by appropriate configuration of the stator windings. The windings are manufactured in two groups, which can then be connected in series or parallel as required. The following voltage combinations are typical:

- **400/690 V in winding configuration Δ/Y**
This is identical to the basic version.
It is suitable for:
400 V for direct or Y/ Δ starting
690 V for direct starting only
There is no reduction in output.
- **230/400 V in winding configuration Δ/Y**
similar to 400/690 V in winding configuration Δ/Y
- **230/460 V in winding configuration Δ/Δ**
similar to 230/400 V in winding configuration Δ/Δ , but without reduced output.

For other voltages, it is necessary to consult the manufacturer.

The use of multi-voltage electric motors is proven above all in mobile applications (e.g. motors for marine use), where operation requires connection to mains supplies with different voltages.

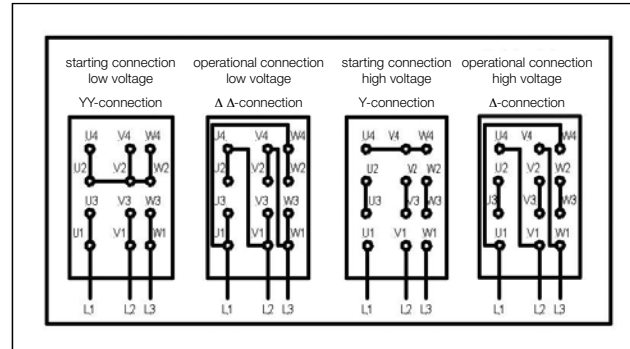

Figure 7: Terminal connection plans for 2 voltages and Y- Δ starting

5. Use of standard three-phase asynchronous motors as single-phase motors

Any three-phase squirrel-cage motor can be operated on a single-phase mains if the required phase shift is produced by an operating capacitor ("Steinmetz circuit"). The circuit is shown in Fig. 8.

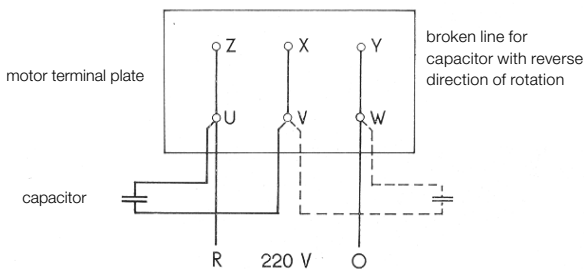

Figure 8: Connection of a 230/400 V three-phase motor as a single-phase motor with operating capacitor

Capacitor size is important for smooth operation. To achieve the required starting torque, a large capacity is needed

for the short-circuit current phase shift. For a phase shift matching the rated operation of the motor, the chosen capacity for the capacitor should not be too large. Starting behaviour is improved if a starting capacitor (which is then switched off after startup) is connected in parallel to the operating capacitor. Selecting a capacitor size from the table below gives the following operating behaviour:

- Output max. 70 % of three-phase output
- Starting torque approx. 20–30 % of the rated torque in single-phase operation

Due to low initial torques and unfavourable main characteristics, these motors can only be used with reduced starting loads, e.g. for fan drives. Motor operating capacitors should normally be designed for continuous operating voltages of 1.2 to 1.5 times the mains voltage, i.e. at least 276 V for a 230 V mains. For other mains voltages, the capacitor size should be calculated as the inverse ratio of the square of the mains voltage.

For technical and economic reasons, the use of a three-phase motor with continuous operating capacitor as a single-phase motor is only meaningful up to a single phase output of around 1 to 2 kW.

Output P_2 for single-phase operation in kW	Capacity C μF	
	at 3,000 rpm	at 1,500 and 1,000 rpm
0.2	16 – 20	20 – 30
0.4	25 – 40	30 – 40
0.6	40 – 50	50 – 60
0.8	60 – 80	70 – 90
1.0	80 – 100	90 – 100
1.2	100 – 120	120 – 140
1.4	120 – 140	140 – 160

6. Selecting a motor

Drive design and the right choice of a motor are instrumental in determining the cost-benefit ratio, avoid setbacks in operation and play a decisive role for economic efficiency. When selecting a motor, all contributing factors such as power demand, operating mode, speed, mains/starting/braking/control conditions, bearing/shaft loads and ambient conditions must be taken into account.

The right choice will often be the basic version. It is therefore assumed for the different operating modes that there is a return to duty type S1 (continuous duty) such that motors are used in the basic mode.

7. Reaction torque, power consumption, moment of inertia

The mechanical power required by a driven machine for continuous duty or at equilibrium in any other operating mode is determined as follows:

$$P_A = \frac{M_g \cdot n_A}{9550} \text{ in kW}$$

where M_g = reaction torque of the driven machine in Nm
 n_A = speed of the driven machine in rpm

For directly coupled drives, this is also the power consumption ($P_A = P_2$) of the motor. If a torque converter (gear unit, belt drive) is placed between the machine and drive motor, the power consumption of the motor is calculated with

$$P_2 = \frac{P_A}{\eta_G} = \frac{M_g \cdot n_A}{9550 \cdot \eta_G} \text{ in kW}$$

where η_G = torque converter efficiency

The aforementioned equations apply only to purely rotational motions. The reaction torque for machines with linear motions must be determined as follows:

$$M_g = 9,56 \cdot \frac{F_A \cdot v}{n_M \cdot \eta_G} \text{ in Nm}$$

where F_A = load in N
 v = speed in m/s
 n_M = motor speed in rpm

The reaction torque and power consumption of a machine are generally a function of the speed. To improve understanding between manufacturers and the users of motors, examples of characteristic reaction torque behaviour are specified and described below (Fig. 9).

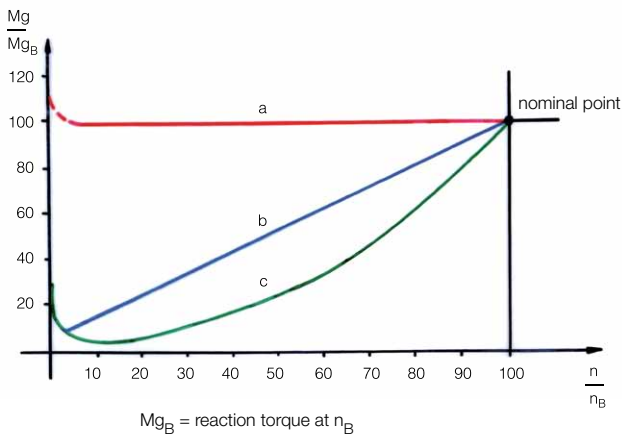

- **Torque practically constant over speed (a)**
 This is the case, for example, for lifting gear, winches, conveyor belts, compressors, when conveying against constant pressures, etc.
- **Linear rise of torque with speed (b)**
 for example for the drives of generators working against constant loads, frequency converters, etc.
- **Torque rises at a specific power (e. g. parabolic) of speed (c)**
 This behaviour is found in the drives of fans, rotary pumps, centrifuges, etc.

Figure 9: Reaction torque characteristics of machines

Other forms of torque behaviour are possible in practice, but these are of lesser importance or else can be traced back to the characteristics explained. Please note that increased friction or adhesion torques may occur at speeds close to zero; such torques are known as breakaway torques and may reach considerable levels (e. g. starting of a piston compressor at low temperatures). These breakaway torques should be known as accurately as possible and must be taken into consideration when assessing starting behaviour.

where J_M = motor moment of inertia
 (to be taken from the technical data of the motor series in question)
 J_F = motor-speed-related sum of moments of inertia of the driven components

Once the moment of inertia of a driven machine has been determined for the speed of the machine using known procedures, the following conversion yields the motor shaft speed:

The total moment of inertia of a drive can be described with

$$J = J_M + J_F$$

$$J_F = \left(\frac{n_A}{n_M} \right)^2 J_A$$

where J_A = moment of inertia of the driven machine at n_A

8. Motor selection for different duty types

This section deals with motor selection on the basis of electric/thermal loads. The decisive parameter when determining motor output is not simply the load at equilibrium. Allowance must also be made for dynamic processes, the final criterion being compliance with a permissible winding temperature rise.

Prerequisite for assignment to a duty type is a load diagram or working cycle showing the torques and outputs to be delivered by the drive, referred to the desired motor speed, over a certain course of time.

8.1. Motor output for continuous duty (duty type S1)

Here, selection is simple because load either does not change or at most fluctuates. The technical data enable selection of a motor with an output equal to or greater than the constant or effective load. The following thus applies for constant load

$$P_{2B} \geq P_A = \frac{M_g \cdot n_A}{9550}$$

where M_g = reaction torque of the driven machine in Nm
 P_{2B} = motor rated output (list output) in kW
 P_A = power consumption of a driven machine in kW
 n_A = machine speed in rpm

If loads fluctuate, the following criteria are used for selection:

$$P_{2B} \geq P_{Am} = \frac{M_{geff} \cdot n_A}{9550}$$

$$\text{where } M_{geff} = \sqrt{\frac{M_1^2 \cdot t_1 + M_2^2 \cdot t_2 + \dots + M_n^2 \cdot t_n}{t_1 + t_2 + \dots + t_n}}$$

M_{geff} = effective reaction torque in Nm
 P_{Am} = mean power consumption of the machine in kW

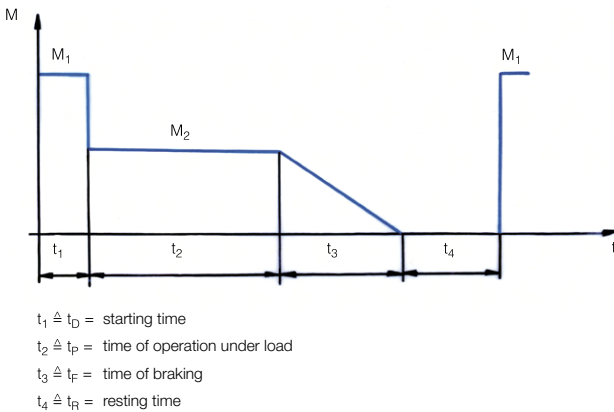

Figure 10: Example of a working cycle

The individual load portions should be sufficiently small, i.e. $t_n < \tau_1$ or $t_n \ll \tau_2$, where τ_1 and τ_2 stand for the thermal time constants of the motor. If t_n is greater, select the motor according to the highest occurring load portion.

When selecting motors for continuous duty, it is important to ensure that

- the rated output of the selected motors lies as closely as possible above the power consumption, as severely underloaded motors yield poor operating values. On the other hand, there is very little room for overloading due to the high utilisation of modern motors
- attention is given to the starting frequency of the drive. If several start-ups are required per hour, for example, then consultation with the manufacturer may be appropriate, depending on the severity of starting conditions. Design work should follow the rules for switching modes as explained below, as this is no longer S1 operation.

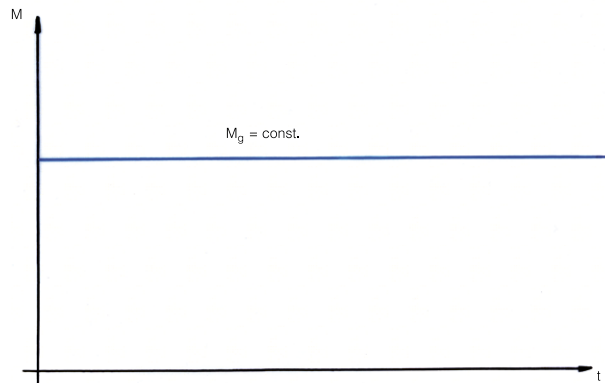

Figure 11: Reaction torque in continuous duty S1

8.2. Motor output in short-time duty (duty type S2)

First use power consumption P_2 for the load phase in S1, as determined from the equations above, to select a motor, then check the corresponding conditions for duty type S2. The following applies:

Operating time $t_p < 3 \cdot \tau_2$
 Interval time $t_R > 3 \cdot \tau_{2St}$

where τ_2 = thermal time constant of the motor in operation
 τ_{2St} = thermal time constant of the motor at standstill (cooling)

In general, the conditions for short-time duty S2 are met by operating periods up to around 60 minutes with correspondingly longer interval times. Preferred values for the operating periods are given in the next table. The permissible output P_{S2} for the selected motor in duty type S2 is determined as follows:

$$P_{S2} = P_{2B} \cdot \sqrt{\left(1 + \frac{K_1}{K_2}\right) \cdot q - \frac{K_1}{K_2}}$$

$$q = \left(1 - \frac{\Theta_2}{\Theta} \cdot e^{-\frac{t_{S2}}{\tau_2}}\right)^{-1}$$

where q = loss factor
 P_{2B} = motor rated output in S1 according to the technical data
 K_1/K_2 = ratio of no-load to load losses for rated operation of the motor
 Θ_2/Θ = ratio of overtemperature referring to τ_2 to total overtemperature
 t_{2S} = load time in S2

An appropriate motor has been chosen if $P_{S2} \geq P_A$, where P_A represents the actual power consumption. If necessary, repeat the calculation for neighbouring motor sizes.

Output in short-time duty S2 is greater than motor rated output P_{2B} . As a further boundary condition, therefore, consideration must be given to the relative pull-out torque. In accordance with IEC/EN 60034-1, the following applies:

$$\frac{M_K}{M_{BS2}} \geq 1,6$$

where M_K = pull-out torque of the selected motor
 M_{BS2} = rated torque of the motor at P_{S2}

If this requirement is not met, a larger motor must be selected, regardless of the thermal utilisation.

Symbol	Design data	
	Type	Preferred value
S1	Operating time	continuous
S2	Operating time	0.5; 1; 3; 5; 10; 30; 60; 90 min
S3 S6	Period of one cycle	10 min
S4 S5 S7 S8	Switching frequency	60, 90, 120 240, 600 c/h
S3 S4 S5 S6	Relative cyclic duration factor c.d.f.	15 %; 25 %; 40 %, 60 %
S4 S5 S7 S8	Moment of inertia factor FI	1.2; 1.6; 2; 2.5; 4

8.3. Motor output in intermittent pericodic duty (duty types S3, S4, S5, S7)

Knowing that the load diagrams (working cycles) for transient processes may be incomplete, it is advisable to start with a rough motor selection. To this end, the aforementioned effective torque method can be used.

$$M_{geff} = \sqrt{\frac{M_1^2 \cdot t_1 + M_2^2 \cdot t_2 + M_3^2 \cdot t_3 + \dots + M_n^2 \cdot t_n}{t_1 + t_2 + t_3 + \dots + t_n}}$$

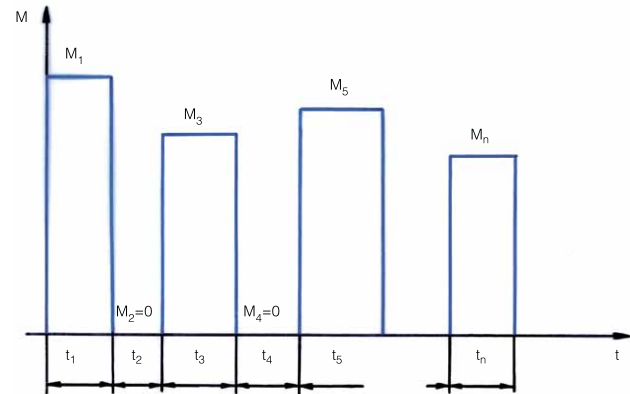

Figure 12: Simplified reaction torque behaviour in intermittent/switching mode

Trapezoidal and triangular sections of the working cycle can be converted to a constant torque during the load phase as follows:

$$M_{Tr} = \sqrt{\frac{M_a^2 + M_a \cdot M_b + M_b^2}{3}}$$

$$M_{Dr} = \frac{M_a}{\sqrt{3}}$$

The approximate output is then determined with

$$P_A = \frac{M_{g\text{eff}} \cdot n_A}{9550} \text{ in kW}$$

Taking into account frequent transient processes, it may already be necessary to select a larger motor. Now, the permissible switching frequency for the selected motor can be calculated under the prevailing conditions:

$$Z_{zul} = \frac{1}{Fl} \cdot f_B \cdot f_S \cdot Z_0 \quad Fl = (J_M + J_F) / J_M$$

where Z_{zul} = permissible switching frequency

Fl = moment of inertia factor

f_B = load factor

f_S = switching factor for the type of connection

Z_0 = no-load switching frequency in c/h

The load factor f_B allows for the cyclic duration factor (c.d.f.) of the drive and the loss factor f_V of the selected motor. It is defined as

$$f_B = (1 - m_g^2) \frac{\text{c.d.f.}}{100\%} + f_V (1 - \frac{\text{c.d.f.}}{100\%})$$

The switching factor f_S makes particular allowance for the type of braking used.

$$f_S = 1 - \frac{m_g}{\bar{m}_A} \quad \text{for switching mode with mechanical braking (e.g. S4)}$$

$$f_S = 1 - \left(\frac{m_g}{\bar{m}_R} \right)^2 \quad \text{for switching mode with counter-current braking or reversing operation (e.g. S5, S7)}$$

$$f_S = 1,08 \frac{(1 + \frac{m_g}{\bar{m}_B})(1 - \frac{m_g}{\bar{m}_A})}{2 + \frac{m_g}{\bar{m}_B} - \frac{m_g}{\bar{m}_A}} \quad \text{for switching mode with DC braking}$$

If the reaction torque during starting and/or ramp-up is less than during operation at rated speed, proceed as follows:

- Calculate the switching factor f_S with the mean relative reaction torque during ramp-up.
- Determine the load factor f_B with the relative reaction torque occurring at rated speed.

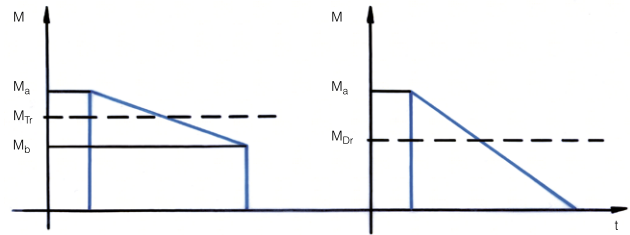

Figure 13: Trapezoidal and triangular reaction torques

In switching modes with mechanical and DC braking, Z_{0A} is used for Z_0 ; in switching modes with counter-current braking and reversal, Z_{0R} is used.

m_g = relative resistance (load) moment referred to the rated torque of the motor

c.d.f. = relative on period in %

f_V = loss factor

\bar{m}_A = mean relative starting torque

\bar{m}_R = mean relative reversing torque

\bar{m}_B = mean relative DC braking torque

To complete the load diagram and for accurate calculation of the relative on period ED, determine the times for transition processes as follows:

$$\text{Starting time } t_D = T_{AN} \frac{Fl}{\bar{m}_A - m_g}$$

$$\text{Reversing time } t_{rev} = 2T_{AN} \frac{Fl}{(\bar{m}_R - m_g)(1 + m_g / \bar{m}_R)}$$

$$\text{Braking time } t_F = T_{AN} \frac{Fl}{\bar{m}_B + m_g}$$

$$\text{where } T_{AN} = \frac{J_M \cdot n_B}{9,55 \cdot M_B} = \text{normal motor starting time in seconds}$$

J_M = moment of inertia of the motor in Nm²

n_B = rated speed in rpm

M_B = rated torque in Nm

The magnitude of \bar{m}_B depends on the braking circuit used and the level of the exciting current, and cannot be specified as a general value (see also section 10).

Finally, it must be checked that sufficient torque overload capacity is available.

$$\text{The following applies } \frac{M_K}{M_{g\text{max}}} \geq 1,6$$

where M_K = pull-out torque of the selected motor

$M_{g\text{max}}$ = max. reaction torque in the working cycle

Particularly in intermittent duty S3, the effective torque procedure is sufficient to determine the required motor output. As per definition, switching operations need not be taken into consideration here.

$$M_{\text{geff}} = \sqrt{\frac{M_g^2 \cdot t_p}{t_p + t_R}}$$

where t_p = load time
 t_R = interval time

The following then applies for motor selection:

$$P_{2B} \geq P_A = \frac{M_{\text{geff}} \cdot n_A}{9550} \text{ in kW}$$

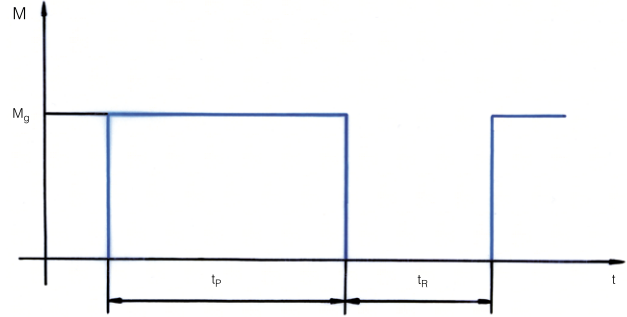

Figure 14: Working cycle in duty type S3

8.4. Motor output in continuous-operation periodic duty (duty type S6)

No general rules can be given regarding selection of a motor for this mode, as the motor size is essentially dependent on the high thermal loads of the given transient processes. It is thus necessary to contact the manufacturer, specifying the following data:

- t_p = load time
- t_v = no-load time
- f_0 = ratio of no-load losses to total losses at rated torque (generally assumed to be 0.4 to 0.5)

$$M_{\text{geff}} = \sqrt{\frac{M_g^2 \cdot t_p + (f_0 \cdot M_B)^2 \cdot t_v}{t_p + t_v}}$$

where M_g = reaction torque (load)
 M_B = motor rated torque

An appropriate selection is determined with

$$P_{2B} \geq P_A = \frac{M_{\text{geff}} \cdot n_A}{9550} \text{ in kW.}$$

Checking of the torque overload capacity is performed as described in section 8.3.

8.5. Motor output in continuous-operation periodic duty with realated load/speed changes (duty type S8)

No general rules can be given regarding selection of a motor for this mode, as the motor size is essentially dependent on the high thermal loads of the given transient processes. It is thus necessary to contact the manufacturer, specifying the following data:

- driven machine
- full working cycle (reaction torques and operating times at the specific motor speeds)
- moment of inertia of the driven machine, including transmission elements, with specification of the reference speed
- on period per working cycle and planned switching frequency
- possible braking processes at the end of the working cycle; type of braking, braking torque

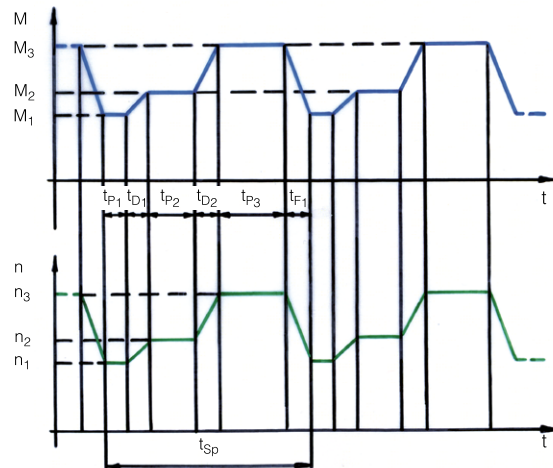

Figure 15: Working cycle in duty type S8

8.6. Operation with non-periodic load/speed changes (duty type S9) and discrete constant loads and speeds (S10)

For this mode of operation, select a constant-load motor to suit mode S1, making allowance for the frequent overloads which arise with this duty type.

9. Squirrel-cage motor starting

Direct starting

In this case, the motor is connected to the mains directly in accordance with its rated voltage. This is the simplest and most reliable type of starting for squirrel-cage motors and should be preferred. The full capacity of the motor is used for ramp-up, and the thermal load is normally kept to a minimum. Direct starting is in fact a must when starting against constant torques or reaction torques which rise steeply with increasing speed, and when accelerating large centrifugal masses (heavy load starting).

With direct starting, the mains must of course handle the full starting current of the motor, which can generally reach 4 to 8 times the motor rated current, depending on the size of the motor and the number of poles. Given today's stable mains, however, it can be assumed that this convenient type of starting can be used almost universally.

The paragraphs below describe a number of procedures for mains and drive conditions which do not allow direct starting.

Star-delta starting

Y/Δ starting is suitable only for motors whose operational winding is connected in Δ, with all 6 winding ends running out to the terminal board (e.g. 230 Δ, 400 Δ, 500 Δ). When starting, the winding is first connected to the mains in star configuration, causing the starting current and starting torque to drop to about 30% of their rated values. After ramp-up to a speed close to the rated speed, the winding is switched over to the operational Δ connection. When using Y/Δ starting, it is imperative to observe the following:

- Since the starting torque has been reduced to about 30 % (applicable to the entire torque behaviour of the motor), it is only permissible to start without load or with a correspondingly low reaction torque, so that sufficient acceleration torque remains available for ramp-up. At each point of the ramp-up curve, the motor torque should be about double the reaction torque applicable at the time, so as to obtain reasonable starting times and to avoid impermissible heating of the motor winding.
- If in doubt, the torque-speed characteristics of a motor can be requested from the manufacturer.

The switchover from Y to Δ must not be triggered before the motor has reached a speed close to rated speed. If switchover is too early, this negates the effect of starting current reduction.

On the other hand, the Y stage should not be prolonged unnecessarily, as this may lead to impermissible heating of the motor windings. The ideal switchover point can be derived after calculation of the starting time (described below), either by testing or by current measurement (for manual switching).

Y/Δ starting can be realised either with manual switches or contactor control. Corresponding circuit diagrams can be found in the technical literature.

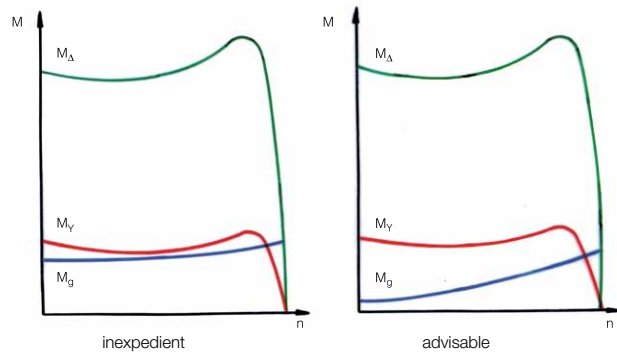

Figure 16: (Un)suitable Y/Δ starting at different reaction torques

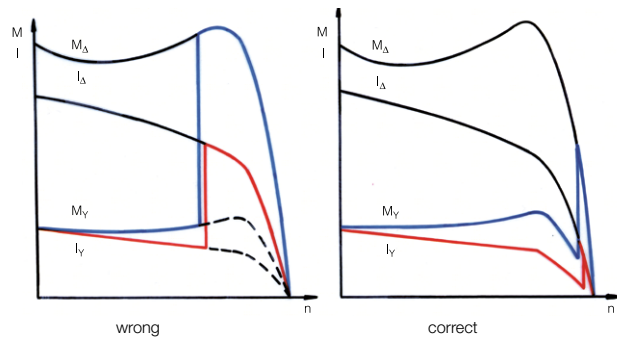

Figure 17: Correct choice of switchover point for Y/Δ connection

Soft starters

The fundamental mode of the motor terminal voltage is controlled via three-phase AC choppers, such that the starting current is reduced. In this way, adjustment to the load characteristic is possible to a certain extent. As the torque is reduced during starting, the notes given for Y-Δ starting also apply for soft starting. Here, too, it is imperative to check the starting behaviour. Torque data for standard motors can be found in the technical data and/or the electronic catalogue VEMeKAT. The related characteristics can also be called up via the electronic catalogue. For special designs, the corresponding data can be requested from the manufacturer.

Starting with frequency converter

During ramp-up in this arrangement, the drive can be accelerated proportionally to the frequency up to rated speed by way of an optimised U/f assignment. During ramp-up with rated current, the rated torque is available over the entire speed range; higher values are possible, depending on the frequency converter used and its individual programming.

Starting time calculation

For many drives, starting time can be determined by way of a mean acceleration torque derived from the torque behaviour of the motor and the reaction torque. The approximate starting time calculated on this basis is

$$t_D \approx \frac{J_{ges} \cdot n_B}{9,55 \times M_{bm}} \text{ in [s]}$$

where J_{ges} = total moment of inertia to be accelerated in kgm^2
 n_B = rated speed in rpm
 M_{bm} = mean acceleration torque in Nm

The starting time is proportional to the total moment of inertia and inversely proportional to the acceleration torque. In this connection, the total moment of inertia J_{ges} for the drive results from the moment of inertia of the motor and the external moment of inertia related to the drive shaft. Mean motor and reaction torques can be derived using suitable procedures for the determination of the arithmetic mean.

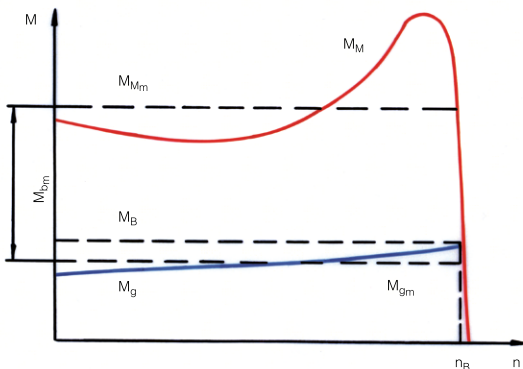

Figure 18: Simplified determination of starting time

For many practical applications, the mean acceleration torque can be determined with sufficient accuracy as follows

$$M_{bm} \approx \frac{M_A + M_K + 4 \times M_S}{6}$$

In certain cases, e.g. special reaction torque behaviours and low acceleration torque, however, this method for starting time calculation is no longer adequate. Starting time should then be determined in steps.

The starting time is calculated with

$$t_D = \sum_{i=1}^{i=n} \Delta t_{D_i} \text{ mit } \Delta t_{D_i} \approx \frac{J_{ges} \cdot \Delta n_i}{9,55 \times M_{bmi}}$$

Δt_{D1} = starting time in section Δn_i in secs
 Δn_i = speed section in rpm
 M_{bmi} = mean acceleration torque in section Δn_i in Nm

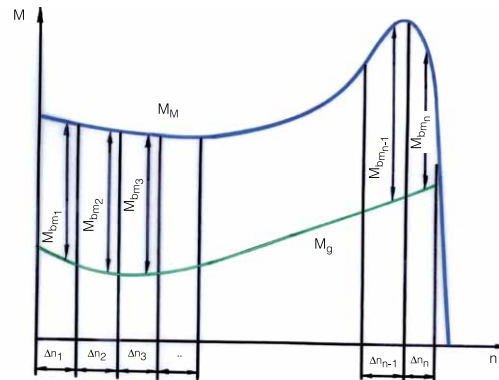

Figure 19: Accurate determination of starting time

The torque behaviour of a squirrel-cage motor can be derived with sufficient accuracy from the values for M_A , M_S and M_K given in the technical data. If necessary, consult the manufacturer for further information.

10. Braking

In certain drive applications, it is not permissible to leave the motor or motor-machine drive unit to handle deceleration and stopping itself. For safety reasons, it is necessary to be able to stop a drive quickly. A drive system can be brought to standstill in a number of ways:

- free coasting to stop
- mechanical braking
- electric braking
- combination of several braking methods (e.g. counter-current braking in connection with a mechanical brake)

Each of these methods has its advantages and disadvantages, and it is thus not possible to give a general recommendation. When designing a drive, the appropriate type of brake should be chosen according to the prevailing operating conditions.

The same technical correlations apply to all braking types, namely that braking time is inversely proportional to the resulting braking torque. The braking time can be calculated with

$$t_F = \frac{J_{ges} \cdot n_B}{9,55 \cdot M_{BrRes}} \text{ in secs}$$

where J_{ges} = total moment of inertia in Nm^2
 n_B = rated speed in rpm
 M_{BrRes} = mean resulting braking torque in Nm

10.1. Free coasting and mechanical braking

The braking torque for these methods stems from the mean reaction torque of the machine, the mechanical losses of the motor, and the mechanical brake. Neither

10.2. Electric braking

With electric braking, the braking torque applied acts in the same direction as the reaction torque of the machine. The resulting braking torque is thus calculated with:

$$M_{BrRes} = M_{BRM} + M_g$$

where M_{BRM} = mean acceleration torque

To be able to design a system for electric braking, the following must be known:

- max. occurring load torque
- moment of inertia to be decelerated
- braking time
- speed, switching frequency, voltage, frequency

Electric braking functions without wear or special maintenance. No specific brake is needed, but the switching is more complex.

When designing the system, it must be noted that the motor is additionally subject to thermal load.

Counter-current braking

This form of braking can be used for both squirrel-cage and slip-ring motors. It is realised relatively simply by swapping two of the three three-phase connections. While the centrifugal masses of the drive continue to act in the original direction, the torque already becomes effective in the opposite direction. When the speed reaches zero, the motor must be switched off electrically to avoid a renewed ramp-up in the opposite direction (e.g. by way of a speed monitor). The braking characteristics are dependent on the rotor design.

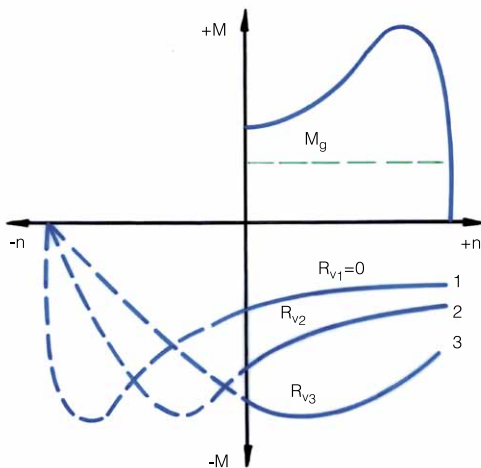

Figure 20: Counter-current braking characteristics

of these two methods affects motor design, as the arising losses place no thermal loads on the motor.

- For squirrel-cage motors

the braking characteristics are dependent above all on the shape of the rotor slot. The assessments found in the technical literature thus range from “modest” to “very powerful” braking action. In practice, testing is advisable.

- For slip-ring motors

the braking characteristics are influenced by the incorporation of additional resistors. Starting and control resistors can be used. The braking effect is greatest where the resistances are changed during braking.

Regarding the thermal loads placed on the motor, it must be noted that the additional warming is around 2 to 3 times that occurring during starting, particularly for squirrel-cage motors, whereas slip-ring motors produce most of the heat externally in the additional resistor. If braking occurs in conjunction with duty type S5, observe the notes given in section 8.3. The duration of occasional counter-current braking should not exceed 10 secs.

DC braking

For this type of braking, the stator of the motor is disconnected from the three-phase mains and subsequently supplied with a direct current after a short interval. The corresponding switching possibilities are shown in Fig. 21. The braking action can be modified by varying the value of the current. The recommended value for the DC braking current is 2 to 2.5 times the motor rated current.

The necessary excitation voltage is calculated with:

$$U_G = I_G \cdot R_{ges} \cdot 1,3$$

where I_G = excitation current (DC)

R_{ges} = total resistance after a short interval

(Fig. 21)

R_{Ph} = phase resistance (Fig. 21)

The braking characteristic can be derived point by point from the motor characteristics $M = f(n)$ and $I_1 = f(n)$.

The braking torque is calculated with:

$$M_{Br} = M \left(\frac{K \cdot I_G}{I_1} \right)^2$$

where M = motor torque

K = braking circuit factor (Fig. 21)

I_1 = motor current

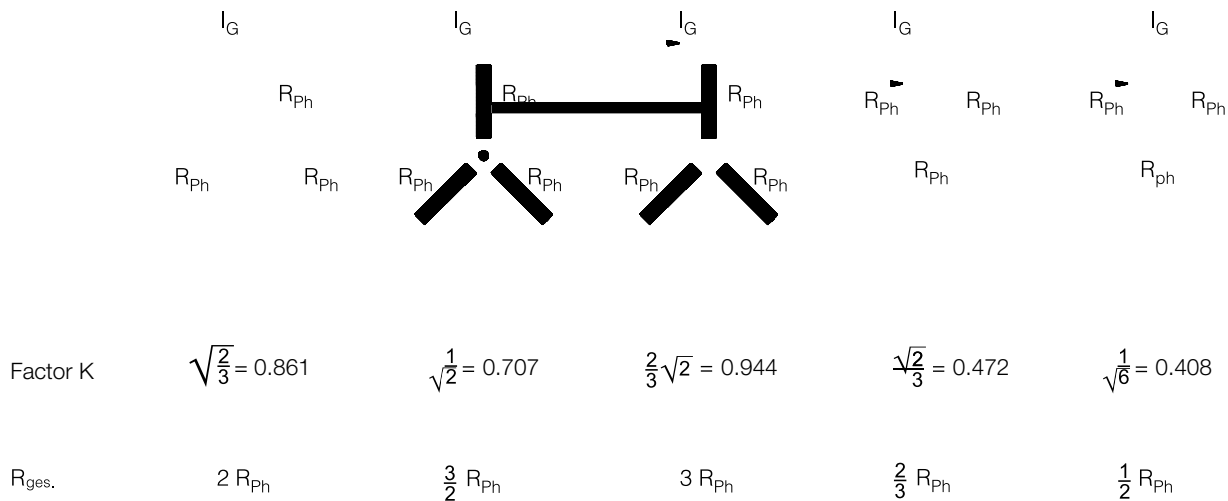

Figure 21: Winding circuits for DC braking

The braking action is gentler than in counter-current braking, there are no shocks acting on the gear unit and/or coupling, and there is no subsequent starting in the opposite direction. Additional mechanical braking may be required towards the end of the braking process. Whether braking is better with DC or counter-current braking can only be decided for an individual case. It is without doubt, however, that DC braking offers a thermal advantage, because the resulting losses are approximately the same as for starting. In case of DC braking in duty type S5, the notes given in section 8.3 must be observed for design.

Supersynchronous braking

Three-phase asynchronous motors operate in the supersynchronous range if

- a passing load accelerates the motor beyond its synchronous speed
- the mains frequency is suddenly reduced, or
- a pole-changing motor is switched from a higher to a lower speed.

Transition to the generator range causes a braking effect above the synchronous speed, though there is no braking to standstill.

Fig. 23 shows the braking characteristics for a two-speed pole-changing motor. If the lower speed is already quite low, absolute standstill can be achieved with subsequent mechanical braking. For supersynchronous braking, it is advantageous that the generator braking torques are greater than the torques in motor operation. Further influence is possible by way of an additional rotor resistance or changes in the stator winding circuit.

When a pole-changing motor is switched back from a higher to a lower speed, the resulting braking torques may far exceed the rated torque for a short period. It may be possible to reduce this braking torque by switching back via the "0" stage, if necessary with a delay.

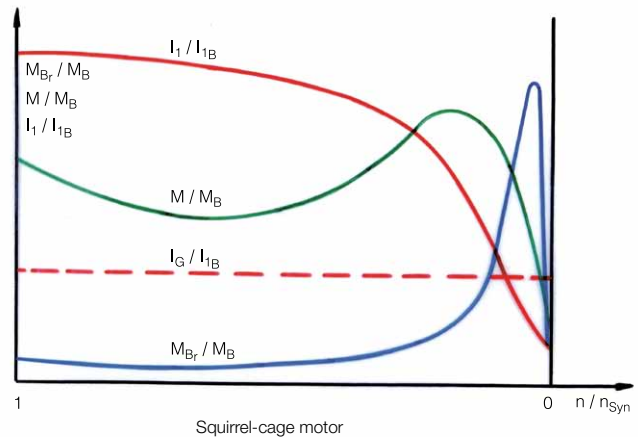

Figure 22: Characteristics for DC braking of a squirrel-cage motor

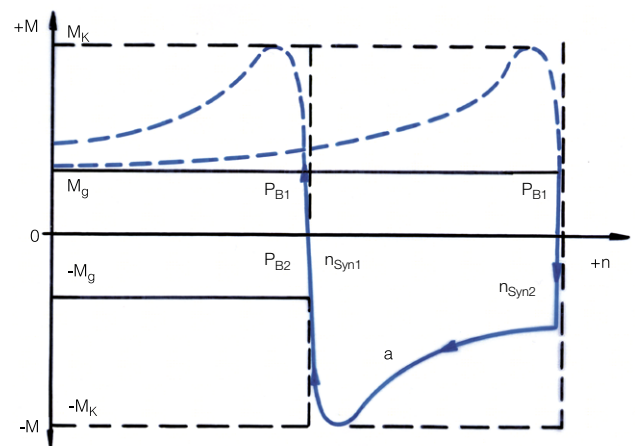

Figure 23: Supersynchronous braking

Subsynchronous braking

Subsynchronous braking arrangements are used exclusively with slip-ring motors. Their primary field of application is in crane operations. For such applications, it is imperative that two phases of the motor are always connected to the mains in order to prevent a free-wheeling situation. The following possibilities are known:

– **Single-phase braking circuit or subsynchronous counter-torque lowering:**

The three phases are interconnected as shown in Fig. 24 and together connected to two line conductors. The rotor is connected to a three-phase resistor.

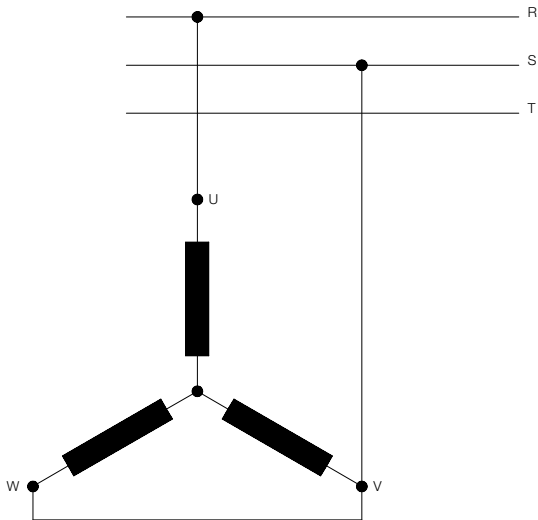

Figure 24: Single-phase braking circuit for the stator winding

– **Double motor circuit:**

Two three-phase machines work together, one as a drive motor, the other as a braking generator.

– **Asymmetrical three-phase braking circuit**

(Fig. 25):

Here, the double motor circuit is incorporated into one machine. The beginning and end connections of one phase of the delta-connected stator winding are swapped.

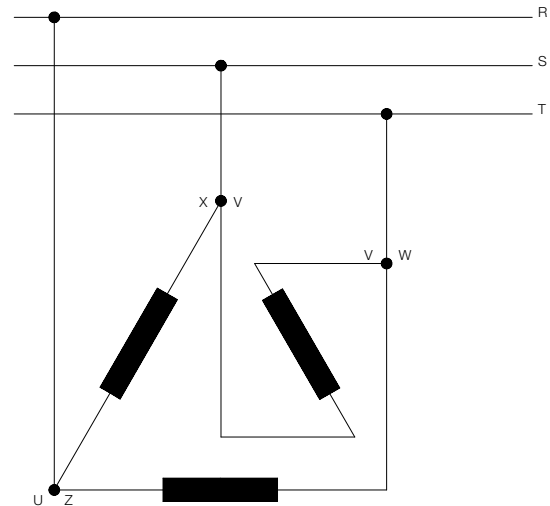

Figure 25: Asymmetrical three-phase braking circuit

11. Generators

When an asynchronous machine exceeds its synchronous speed, it goes into generator operation. The drive torque may be supplied by a hydraulic motor, diesel unit, etc. The amount of the torque depends on the amount of supersynchronous slip and, in the same way as the torque in motor operation, possesses a maximum which is slightly greater than the motor pull-out torque.

The operation of a squirrel-cage motor as an asynchronous generator requires a live mains connection or else excitation via capacitors to supply the reactive current required for magnetisation.

In mains operation, the frequency and voltage of the generator match the parameters of the mains. The active power output depends only on speed, which is automatically adjusted to the available drive power unless the drive torque exceeds the generator pull-out torque. The speed

lies approx. 1 to 3 % above the synchronous speed. When working with connection to the public grid, appropriate feed-in conditions must be discussed with the utility company in advance. Further details can be found in the “Technical Requirements for Connection to the Low-Voltage Grid” (TAB 2000).

In isolated operation, the magnetisation current is drawn from capacitors, whose size depends on the reactive power consumption of the generator and the size and type of consumers to be supplied. In addition, the dielectric strength of the capacitors should be set to the peak value of the voltage produced in the given circuit. Careful design is here imperative, as the system (generator – capacitor – load) reacts to speed and load changes with strong fluctuation of the voltage and frequency.

12. Mechanical transmission elements

To ensure smooth and shock-free running, the place of installation of the motor must be chosen carefully. It should stand on an exactly level surface, and the transmission elements to be mounted on the shaft end should be (dynamically) balanced. If this is neglected, the (antifriction) bearings will suffer additional loads and damage.

Motor output is generally transmitted to the machine via

- couplings
- belts
- chains
- gears.

It is up to the designer to find the optimum solution for a particular drive application, taking into account all structural and economic factors.

Generally speaking, the outer contours of the transmission elements to be mounted on the motor shaft end must never project beyond the shaft end shoulder, and only standard transmission elements should be used. If self designed parts must be used as an exception, they must nevertheless meet all requirements of the applicable stan-

12.1. Coupling drives

Direct couplings are used for most driving and driven machines. Only flexible or special elastic positive couplings should be used. Couplings require very careful aligning of individual machines, i.e. the shaft centres must stand in precise alignment.

Certain inaccuracies in the individual machines may be compensated by the coupling, depending on the type of coupling chosen, but they will nevertheless place considerable loads on the bearings and shafts and result in uneven/unsteady running. The result will be greater or lesser destruction of the bearings, motor shafts and transmission elements of couplings. The better the alignment of machines connected by couplings, the lower the extra loads to be expected and the greater the functional reliability.

Rigid couplings should always be avoided, as they are unable to compensate even the slightest misalignment. As the warming of a cold motor to operating temperature necessarily leads to linear expansion of the shaft, the use of a rigid coupling can already destroy the bearings of the motor or the driven machine after just a short time, and is therefore not authorised by the motor manufacturer.

12.2. Belt drives

Belt drives are used mainly where

- the driving and driven machines must run at different speeds,
- the shafts are not in one plane,
- flexible power transmission is needed,
- shock and vibration damping is to be achieved.

The most commonly used belts are flat and V-belts in a variety of designs and materials. The preference for one or the other of the two types is dependent on their specific properties and is dealt with in the technical literature.

The following points must be observed when designing belt drives:

- Belt pre-tensioning must be adjustable. e.g. by way of tensioning bars, rolls or rockers.
- The shafts of the driving and driven machines must be exactly parallel.
- Where several belts are used on a pulley, endless belts are recommended. Such belts should be kept in stock and similarly replaced, when necessary, in sets.

dards with regard to manufacturing accuracy, balancing, limits of use, etc.

The following sections describe the effects of drive element masses and forces (F_G in N) on the radial (F_r) and axial forces (F_a) for horizontal and vertical shafts. Where the angle of the motor axis is inclined $>15^\circ$ relative to the horizontal/vertical, the force (F_G) generated by the mass of the drive elements must be apportioned geometrically to F_r and F_a .

When using torsionally flexible couplings (plate or bolt couplings), it must be noted that the coupling and the masses it connects form a vibrating system with a certain natural frequency. This natural frequency is reduced by softer couplings and increased by harder ones. Where drives are subject to periodic shocks, it must be ensured that the frequency of the shock moments does not coincide with the natural frequency. Resonance or near-resonance may result in greater vibration amplitudes and loads in the system.

The size of a coupling is selected on the basis of the rated torque on the motor shaft.

$$M_B = \frac{9550 * P_{2B}}{n_B}$$

where M_B = motor rated torque [Nm]
 P_{2B} = motor rated output [kW]
 n_B = rated speed [rpm]

Operational loads must be taken into account by selecting a coupling of an appropriate size.

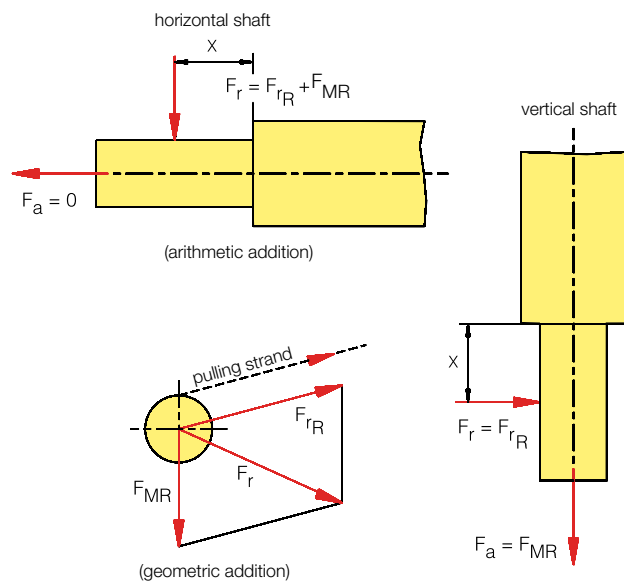

Figure 26: Shaft loading in belt drives

If the aforementioned measures are observed, uncontrolled reduction of the belt service life of belt systems can be avoided, and premature damage to the driving and driven machines due to uncontrolled loads on the shaft ends and bearings can be averted.

Determining the pulley dimensions

Pulleys must be dimensioned such that the permissible values for F_r and F_a on the shaft end are not exceeded. The radial force F_{rR} in belt drives is composed of the pull and the pre-tensioning of the belt. The latter is taken into account with the factor c_v when determining F_{rR} .

Approximate values are

- 2...2.5 for V-belts
- 2.5...3 for standard flat leather belts with tensioning rolls
- 4...5 for standard flat leather belts, rubber belts, etc. without tensioning rolls

The radial force for a given pulley can be determined with

$$F_{rR} = 2 \cdot 10^7 \frac{P_{2B} \cdot c_v}{n_B \cdot D}$$

12.3. Chain drives

Contrary to a belt drive, a chain drive represents a positive transmission element with no slip, even in case of short distances between the axes and high transmission ratios. Compared with gear drives, chain drives are to some extent elastic and are also able to span larger distances between axes without intermediate sprockets.

The radial force acting on the motor shaft end can be determined with

$$F_{rKe} = 2 \cdot 10^7 \frac{P_{2B}}{n_B \cdot D} \cdot c_k \cdot c_d$$

where F_{rKe} = radial force [N]
 P_{2B} = motor rated output [kW]
 c_k = factor taking into account the additional force arising in chain drive itself

where F_{rR} = radial force [N]
 P_{2B} = motor rated output [kW]
 c_v = belt pre-tensioning factor
 n_B = motor rated speed [rpm]
 D = pulley diameter [mm]

The inertia force is calculated as follows:

$$F_{MR} = m_R \times g$$

where F_{MR} = inertia force [N]
 m_R = pulley weight [kg]
 g = gravitational acceleration [9.81 ms⁻²]

Geometric addition is possible for very large pulleys. The effective direction of F_{rR} is invariably towards the driving side. The shaft loads F_r and F_a result as shown in Fig. 28. The dimension x is the distance from the pulley centre to the shaft shoulder. The values F_r , F_a and x can be used to check on the permissibility of loads in accordance with the "Technical explanations".

If the permissible load is exceeded and no significant modification of the load is achieved by choosing a different belt with different pre-tensioning, a pulley with a larger diameter must be selected.

c_d = factor taking into account the additional force emanating from the machine
 n_B = motor rated speed [rpm]
 D = reference circle diameter of the chain wheel used [mm]

The effective direction of F_{rKe} is always towards the driving side.

On motors with horizontal shafts $F_a=0$, on vertically oriented motors $F_a=F_{MKe}$. F_r , F_a and x and determined in the same manner as described in Fig. 28.

$$F_{MKe} = \text{inertia force of the chain wheel [N]}$$

If the permissible shaft load is exceeded, reference circle diameter of the chain wheel must be increased.

No. of engagements	Type of teeth	Factor c_k
1	Precision gear wheels (pitch errors/form defects < 0.02 mm)	1.05 ... 1.1
	Standard planed/milled gear wheels and chain wheels (error 0.02–0.10 mm)	1.1 ... 1.3
	Standard planed/milled gear wheels and chain wheels (error 0.02–0.10 mm)	1.5 ... 2.2
2	Precision gear wheels	0.6 ... 0.7
	Standard planed/milled gear wheels	0.7 ... 0.8
The lower values apply at low tooth speeds of $v \leq 2$ m/s		

Factor c_k for chain and gear drives

Type of machine	c_d
Prime movers	
Electric machines, turbines	1.0 ... 1.1
Electric traction motors in locomotive frames	1.1 ... 1.2
Axle-hung electric traction motors, combustion engines, piston steam engines	1.2 ... 1.5
Transmission systems for driving larger groups of machines	
	1.1 ... 1.3
Conveyors, lifting gear	
Conveyor belts, ropeways, centrifugal pumps, blowers, turbocompressors	1.0 ... 1.2
Mine fans	1.1 ... 1.3
Elevators, cranes	1.2 ... 1.3
Piston compressors	1.2 ... 1.5
Reciprocating pumps, depending on balancing	1.5 ... 1.6
Hoisting equipment	1.5 ... 1.8
Oscillating conveyors	1.5 ... 2.5

Factor c_d for chain wheel/gearwheel drives

12.4. Gear drives

Gear drives transmit outputs and speeds without slip and are used above all where the distance between the axes of the driving and driven machines is small and different speeds are required.

Generally, it is possible to distinguish

- straight spur gears, where only radial forces arise in power transmission
- helical spur gears, bevel gears, etc., where both radial and axial forces occur in power transmission

Straight spur gear drives

The radial force F_{rZg} is determined with

$$F_{rZg} = 2 \cdot 10^7 \cdot \frac{P_{2B}}{n_N \cdot D_T} \cdot c_k \cdot c_d$$

where F_{rZg} = radial force [N]

P_{2B} = motor rated output [kW]

c_k = factor taking into account the additional force arising in gear drive itself

c_d = factor taking into account the additional force emanating from the machine

n_B = motor rated speed [rpm]

D_T = reference circle diameter of the gear wheel used [mm]

The effective direction of the radial force F_{rZg} is shown in Fig. 27.

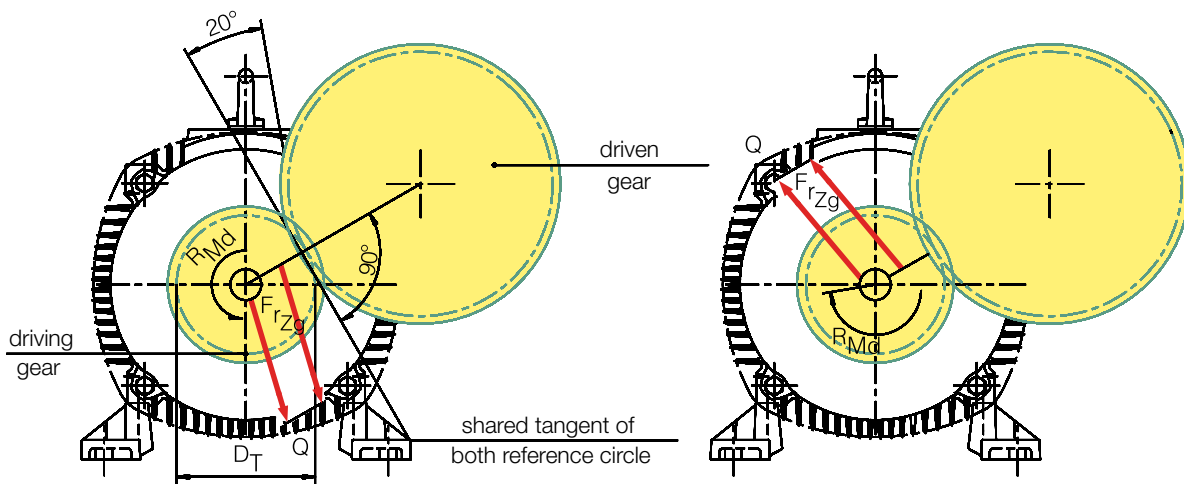

Figure 27: Effective direction of radial force in spur gears

The radial force F_{rZg} for spur gears always acts under 20° to the joint tangent of the reference circles of the driving and the driven gear.

The following load diagrams take into account the inertia force of the gear F_{MZ} :

For gears with high inertia forces, F_{rZg} and F_{MZ} can also be added geometrically.

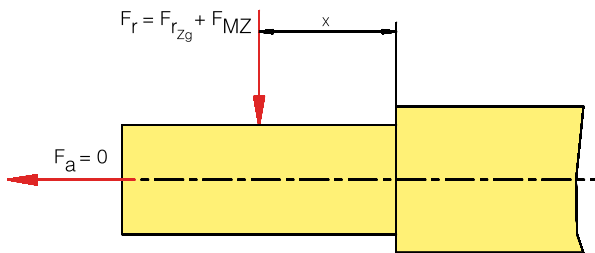

Figure 28: Mechanical drive for a horizontal shaft (straight spur gears)

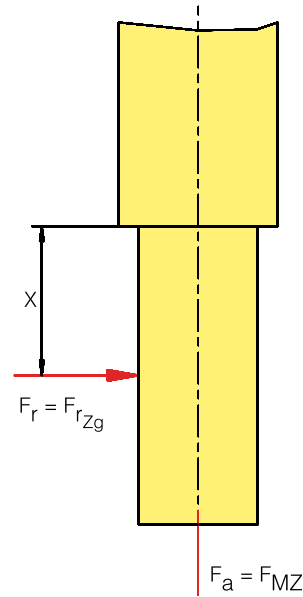

Figure 29: Mechanical drive for a vertical shaft (straight spur gears)

Helical spur gear drives

With helical spur gears, radial and axial forces always occur together, though the latter do not act in the motor shaft axis.

Where bevel gears, etc. are used, it is also necessary to consult the motor manufacturer and to provide similar values as for helical spur gears.

The following points must always be observed for gear drives:

- The shafts of the two machines must be exactly parallel.
- The pinion and mating gear must run absolutely true.
- The pinion teeth must not seize in any position of the mating gear.

If these points are neglected, inadmissible bearing loads, vibration, shocks and disturbing noise must be expected. If a paper strip of the same width as the pinion and mating gear is inserted between the two, turning of the gears will reveal any points of misengagement. It must be ensured that all teeth of both wheels are tested in this way. In accordance with the test results, the machine must be realigned as often as is necessary to achieve uniform smooth engagement for all teeth.

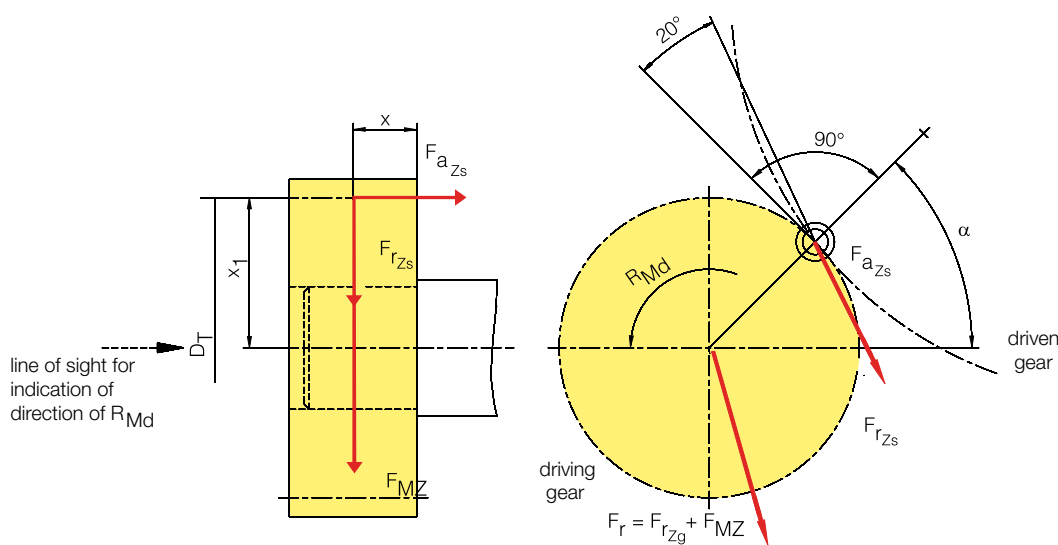

Figure 30: Application of force in helical spur gears with corresponding explanations

13. Slip-ring rotors

13.1 Slip-ring motor starting

Slip-ring motors are started almost exclusively by way of a starter which places additional resistors in the rotor circuit.

The starting torque can be varied freely through corresponding dimensioning of the starting resistor. The highest attainable starting torque lies at the level of the pull-out torque of the motor; the permissible tolerances for the pull out torque in accordance with IEC/EN 60034-1 must be observed.

The rotor voltage at standstill and the rotor rated current, which are required for determination of the appropriate starting resistors, can be taken from the applicable technical data. If the actual power consumption deviates from the list output, the rotor current can be recalculated as follows:

$$I_2 = I_{2B} \frac{P_2}{P_{2B}}$$

where I_2 = rotor current for actual power consumption
 I_{2B} = rotor rated current
 P_2 = actual power consumption
 P_{2B} = rated output

The rotor current which occurs during starting is approximately proportional to the available starting torque and can thus be determined with:

$$I_{2A} = I_{2B} \frac{M_A}{M_B}$$

where I_{2A} = starting current in rotor
 M_A = starting torque
 M_B = motor rated torque

The total value of the additional resistors for the rotor circuit is calculated as follows:

$$R_V = \frac{U_{20}}{\sqrt{3} \cdot I_{2B}} \cdot \frac{M_B}{M_A} - R_2$$

13.2.2. Electric braking

With electric braking, the braking torque applied acts in the same direction as the reaction torque of the machine. The resulting braking torque is thus calculated with:

$$M_{BrRes} = M_{Brm} + M_g$$

where M_{Brm} = mean braking torque

To be able to design a system for electric braking, the following must be known:

- max. occurring load torque
- moment of inertia to be decelerated
- braking time
- speed, switching frequency, voltage, frequency

Electric braking functions without wear or special maintenance. No specific brake is needed, but the switching is more complex.

When designing the system, it must be noted that the motor is additionally subject to thermal load.

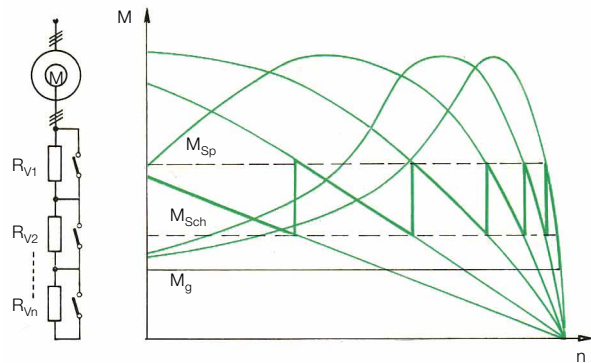

Figure 31: Starting of slip-ring motors with additional resistors in the rotor circuit

where U_{20} = rotor voltage at standstill (from technical data)
 R_2 = equivalent resistance

For crane motors with slip-rotors, R_2 is specified in the technical data. Otherwise, R_2 can generally be neglected. If necessary, it can be requested from the manufacturer or calculated in approximation with:

$$R_2 \approx \frac{U_{20}}{\sqrt{3} \cdot I_{2B}} \cdot \frac{n_s - n_B}{n_s}$$

where n_s = synchronous speed
 n_B = rated speed

The starting or additional rotor resistors are generally disconnected in steps (manually or with contactor control). The number of steps and the individual switching points should be selected such that only low current and torque peaks result. To this end, a multitude of procedures for both symmetrical and asymmetrical starting circuits are described in the technical literature.

Counter-current braking

This form of braking can be used for both squirrel-cage and slip-ring motors. It is realised relatively simply by swapping two of the three three-phase connections. While the centrifugal masses of the drive continue to act in the original direction, the torque already becomes effective in the opposite direction. When the speed reaches zero, the motor must be switched off electrically to avoid a renewed ramp-up in the opposite direction (e.g. by way of a speed monitor). The braking characteristics are dependent on the rotor design.

- For slip-ring motors

the braking characteristics are influenced by the incorporation of additional resistors. Starting and control resistors can be used. The braking effect is greatest where the resistances are changed during braking.

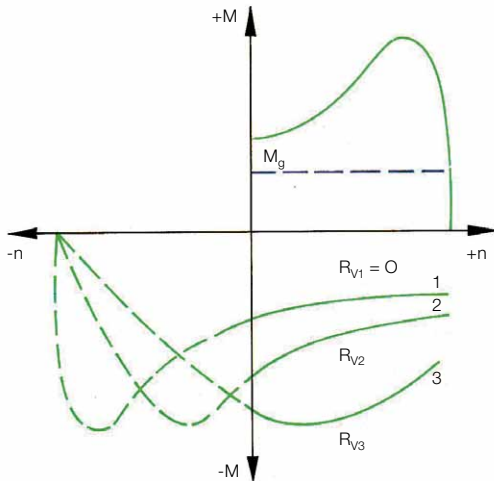

Figure 32: Counter-current braking characteristics

Regarding the thermal loads placed on the motor, it must be noted that the additional warming is around 2 to 3 times that occurring during starting, particularly for squirrel-cage motors, whereas slip-ring motors produce most of the heat externally in the additional resistor. If braking occurs in conjunction with duty type S5, observe the notes given in section 8.3. The duration of occasional counter-current braking should not exceed 10 secs.

DC braking

For this type of braking, the stator of the motor is disconnected from the three-phase mains and subsequently supplied with a direct current after a short interval. The corresponding switching possibilities are shown in Fig. 33. The braking action can be modified by varying the value of the current. The recommended value for the DC braking current is 2 to 2.5 times the motor rated current.

The necessary excitation voltage is calculated with

$$U_G = I_G \cdot R_{ges} \cdot 1.3$$

where I_G = excitation current (DC)
 R_{ges} = total resistance, depending on the braking circuit
 R_{Ph} = phase resistance

The braking characteristic can be derived point by point from the motor characteristics $M = f(n)$ and $I_1 = f(n)$.

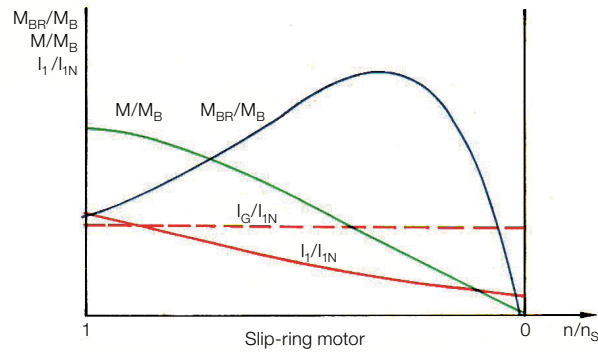

Figure 33: Counter-current braking characteristics for a slip-ring motor

The braking torque is calculated with:

$$M_{Br} = M \left(\frac{K \cdot I_G}{I_1} \right)^2$$

where M = motor torque
 K = braking circuit factor
 I_1 = motor current

Through the incorporation of additional resistors into the rotor circuit of a slip-ring motor, it is possible to achieve greater mean braking torques than with a squirrel-cage motor.

The braking action is gentler than in counter-current braking, there are no shocks acting on the gear unit and/or coupling, and there is no subsequent starting in the opposite direction. Additional mechanical braking may be required towards the end of the braking process. Whether braking is better with DC or counter-current braking can only be decided for an individual case. It is without doubt, however, that DC braking offers a thermal advantage, because the resulting losses are approximately the same as for starting. In case of DC braking in duty type S5, the notes given in section 8.3 must be observed for design.

13.3. Speed control

Control with additional resistors in the rotor circuit

Speed-controlled slip-ring motors can be supplied for the preferred setting ranges 25 %, 50 % and 75 % and for the reaction torque characteristics $M_g = \text{constant}$, $M_g = \text{linear decrease}$ and $M_g = \text{quadratic decrease}$. Due to the poorer efficiency and reduced ventilation, it is not always possible

to achieve the list outputs in operation at speeds below rated speed. The necessary reduction of the standard output, as dependent on the aforementioned parameters, can be taken from the following table.

Speed reduction in %	Output reduction in % of standard output for a given reaction torque characteristic (relative to operation without speed control)		
	constant	linear decrease	quadratic decrease
25	10	0	0
50	20–25	10	0
75	45–50	25–30	0

Speed control with an output reduction of up to 10 % can be realised with slip-ring motors in the basic version. Motors which require an output reduction of more than 10 % are supplied in special design and must be ordered accordingly.

The additional rotor resistors required for the setting range can be determined as follows, taking into account Fig. 34:

$$R_V = \left(\frac{s_r}{s} - 1 \right) \cdot R_2$$

where s_r = slip for the setting range
 s = slip for operation without control

for motors in standard design with standard output

$$s = s_B = \frac{n_s - n_B}{n_s}$$

for motors in standard design with reduced output

$$s = s_B = \frac{M}{M_B}$$

In most cases, it is sufficiently accurate to set $s = s_B$.

for motors in special design with reduced output

$$s = s_{Bh} = \frac{n_s - n_{Bh}}{n_s}$$

where s_B = rated slip
 n_s = synchronous speed
 n_B = rated speed (from technical data)
 M = torque
 M_B = rated torque
 s_{Bh} = rated slip at reduced output with special design
 n_{Bh} = rated speed at reduced output (see rating plate or request from the manufacturer)
 R_2 = equivalent resistance of the rotor winding (for standard version, see technical data; for special designs, consult the manufacturer)
 $R_{2 \text{ warm}} \approx 1.3 \cdot R_2$

As an example, Fig. 35 shows the characteristics of a 6-pole slip-ring motor at 25 % speed setting with linearly decreasing torque.

A modern special version of speed control by way of additional resistors is electronic power control with a pulsed rotor resistor. The circuit for such control is shown in Fig. 36. The change in motor speed is here realised by way of periodic short-circuiting of the additional resistor, which can be equated to continuous modification of the size of this resistor.

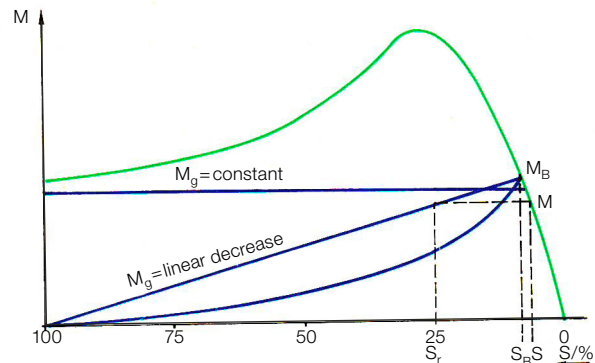

Figure 34: Torque characteristics for a slip-ring motor with speed control

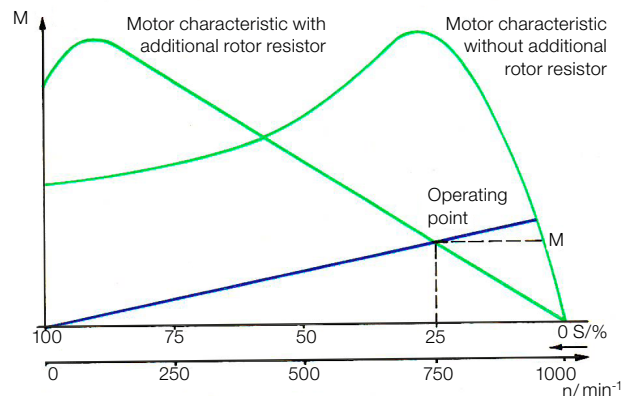

Figure 35: Example of a motor characteristic for speed control by way of an additional resistor

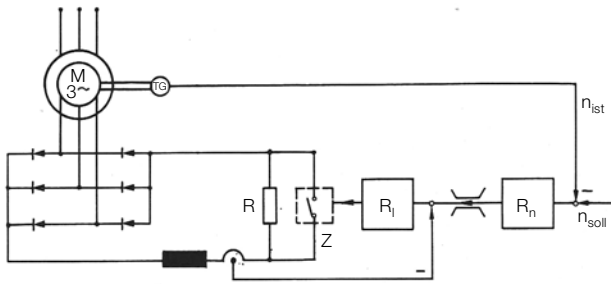

Figure 36: Motor speed control by way of a pulsed rotor resistor

With appropriate control (speed control with secondary two-step current control), it is possible to set any operating point between the limits for permanently short-circuited and permanently active additional resistor. This relatively high outlay, however, is only justified where a demanding technology requires high speed constancy.

Control by way of additional rotor voltages

The speed of a slip-ring motor can be varied freely in either direction to account for varying load by supplying a

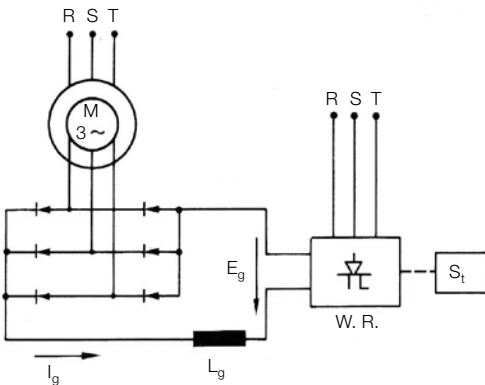

Figure 37: Connection diagram of a subsynchronous converter cascade

13.4. Operation of slip-ring motors with low loads

If a slip-ring motor is operated over a longer period with a load of less than 70 % of the rated output, there is a likelihood of increased brush wear. For this reason, slip-ring motors must be designed such they will not be operated at less than 70 % of the rated output for extended periods.

voltage with slip frequency externally to the slip-ring, either in phase with or in phase opposition to the rotor voltage. This principle is well known for electric machines and is realised in practice, for example, in a three-phase shunt wound motor, where the necessary additional rotor voltage is produced internally by way of a commutator.

If the speed control is limited to the subsynchronous range, significant simplification is possible. It is sufficient to withdraw energy from the rotor. The frequency-dependent rotor voltage can be supplied via a power electronics module with DC link. This module serves to return rotor energy to the grid via a line-commutated inverter. The connection diagram of such an arrangement can be seen in Fig. 37.

The basic load characteristics of the aforementioned subsynchronous converter cascade are shown in Fig. 38. The speed-torque behaviour is characterised by parallel shifting of the curves, where only the straight sections are generally relevant for practical operation.

When designing a drive with speed control, it is almost always necessary to consult the manufacturer, where possible with precise specification of all data which are decisive for the application.

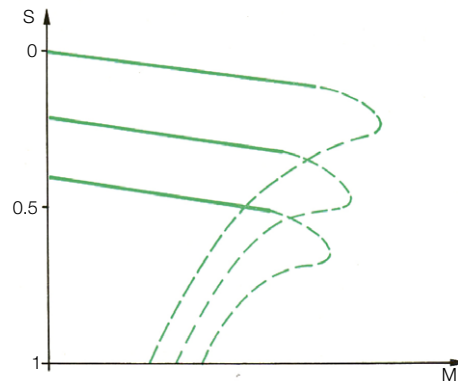

Figure 38: Load characteristic of a subsynchronous converter cascade

In exceptional cases, special agreements must be reached with the manufacturer. The work cycle and operating conditions must be specified, and appropriate testing may be necessary.

13.5. Selsyn arrangements

In certain applications where plant is spread over a wide area, as well as for slide rest drives on lathes or loading gantries, for example, it is necessary to maintain synchronicity between separate section drives. A mechanical shaft connection is often not feasible due to the physical circumstances. The solution is to simulate a shaft by electric means with a so-called selsyn.

A selsyn is set up by connecting like phases on the stator and rotor sides of two or more slip-ring motors. Depending on the requirements with regard to power transmission, angular positioning, etc., there are two commonly used arrangements, namely the power selsyn (Fig. 39) and the differential selsyn (Fig. 40).

Correct planning of an electric synchronisation arrangement requires precise knowledge of the overall system, and in particular of those elements of the drive which interact with the selsyn. This overall view is imperative for proper judgement of the dynamic stability.

The selsyn represents an elastic link between the machine groups, the rotating masses of which are in this way coupled as if by torsion springs and can thus display torsional vibration.

It is imperative to check the dynamic behaviour, as proper functioning of the synchronisation arrangement is no longer guaranteed in case of resonances or inadequate damping of the mutual vibration in the drive groups.

Selsyns can be realised through any of a variety of connection possibilities with different static and dynamic properties; details of the different arrangements can be found in the relevant technical literature.

Dynamic susceptibility is not necessarily attributable to the selsyn; it may also result from resonance phenomena in the overall system. Through suitable design measures, e.g. the targeted placement of balancing masses, it may be possible to rectify such susceptibility. To enable the selection of suitable selsyn machines from the available range of slip-ring motor types, the following information must be provided with the order:

- Description of the overall system in terms of type, design, function principle and operating conditions, where related in any way to the selsyn
- Description of the work cycle, specifying the maximum short-time or continuous torques to be transmitted by the selsyn, together with the corresponding speeds and any existing irregularities in the torque
- Information on the type of the main drive motor, especially with regard to ramp-up properties and the response speed for motor speed control
- Maximum permissible rotation angle between the transmitter and the receiver
- Specification of the type of synchronisation (at standstill or running)
- Rotating masses coupled with the selsyn machines in the different operating states.

The following points should be taken into account for preselection of the most suitable variant:

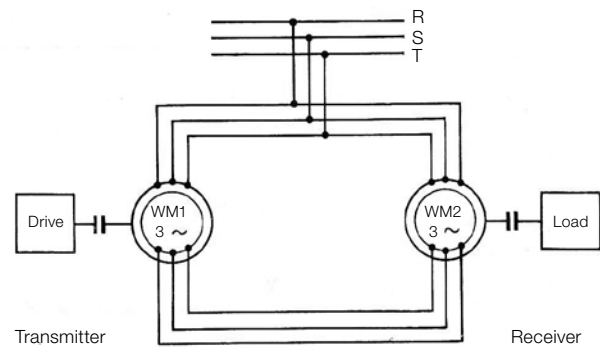

Figure 39: Power selsyn

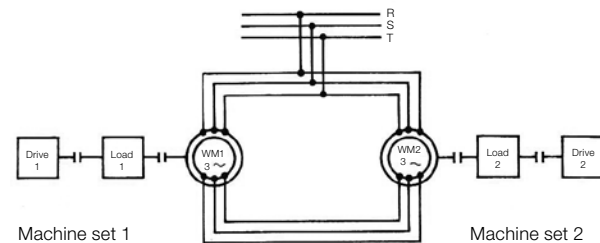

Figure 40: Differential selsyn

For differential selsyns, rotation in opposition to the rotating field is to be preferred, as this enables the best possible type utilisation. The prerequisite, however, is that the dynamic stability of the system remains guaranteed. For this reason, it may be necessary to prefer operation with the rotating field under certain circumstances, if the external damping is only very low and there is no alternative to the use of damping resistors for stabilisation. For power selsyns, rotation in the sense of the rotating field is to be preferred. It is only in special cases, e.g. very high speeds up to and above the synchronous speed or reversing operation where reversal of the rotating field is not possible at standstill, that a power selsyn may also be operated with rotation in opposition to the rotating field.

When the selsyn is operated in opposition to the rotating field, the rotor frequency and rotor voltage reach values which do not otherwise occur in normal operation. The iron losses in the rotor are thus higher than usual. In such cases, particular attention must be paid to the thermal behaviour of the selsyn machines. Normal slip-ring motors possess self-ventilation, the intensity of which is naturally reduced at lower speeds. The losses which can be dissipated at slow speeds are thus significantly lower than in normal operation. For this reason, considerable limitation of the permissible load is often inevitable. When planning a synchronisation arrangement of any kind, therefore, it is always advisable to consult the manufacturer. In many cases, testing will be imperative.

No claims are raised as to the completeness of the information on motor configuration and corresponding applications provided in this chapter. This information is intended merely to help the user to understand drive problems and to confidently preselect a suitable three-phase electric motor for the given drive application. All information has been gathered and checked with the utmost care. Nevertheless, we are unable to accept liability of any kind regarding possible errors, omissions or inconsistencies.

Wherever our customers need electric machines, we are at hand as a partner and offer every necessary support at all phases of a project. It is not important whether you are doing business in Europe, the Middle East, Asia or America. As the VEM market share increases also outside Germany, we are expanding our sales network with a combination of own subsidiary companies and strategic alliances. Already today, our customers can address their questions to competent and experienced local partners all over the world. Alongside VEM subsidiaries in Finland, Great Britain, Norway, Austria and Singapore, we have established a dense network of sales and service contacts with agents and representatives in more than 40 countries.

VEM-Product Range

Low-voltage machines

Three-phase asynchronous motors with squirrel-cage rotor
up to 710 kW as energy saving motors in efficiency classes
IE3, IE2, IE1 according to IEC/EN 60034-30-1/IEC 60034-2-1
Three-phase asynchronous motors with slip ring rotor up to 315 kW
Roller table motors up to 710 kW
Explosion-protected motors up to 630 kW
Crane motors and marine motors
Special motors with brake, forced ventilator, encoder
Compact drives up to 22 kW
Built-in motors
Three-phase asynchronous generators

High-voltage machines

High-voltage asynchronous motors up to 28 MW
High-voltage synchronous motors up to 42 MW
High-voltage synchronous generators to 45 MVA
Traction machines
Wind power generators up to 7 MW

Foundry products

Custom-made castings
Fittings, Valves, Hydrants
Architectural casting

Further information about our delivery program and our product range
you can find in the Internet under www.vem-group.com

You can also request a copy of our electronic catalogue
on a USB stick.

Technical modification

We strive to improve our products whenever and wherever possible. Consequently, technical data
and illustrations remain subject to change. Specifications may only be considered binding following
written confirmation by the supplier

Liability, duty to obtain a permit

All information are without any engagement. For printing errors we don't take over any liability.

Copies, reprints, saving files or publication are only possible with specific acceptance of
VEM motors GmbH.

The products featured in this catalogue are also contained in our interactive VEM catalogue.

Further information on the companies and products of the VEM Group can be found at
www.vem.group.com.

The electronic catalogue VEMeKAT assists you in the selection and configuration of VEM products.
You are able to print out both data sheets and product enquiries, while dimensioned and scale
drawings can be displayed or exported in various 2D and 3D formats. In addition to general
information about the VEM Group, you have direct access via the program to catalogues, spare
parts lists, operating and maintenance instructions, test certificates and circuit diagrams of the
individual products.

VEM Sales

Low voltage department

Tel. +49 3943 68-3127

Fax +49 3943 68-2440

E-mail: low-voltage@vem-group.com

High voltage department

Tel. +49 351 208-3237

Fax +49 351 208-1108

E-mail: high-voltage@vem-group.com

Drive systems department

Tel. +49 351 208-1180

Fax +49 351 208-1185

E-mail: drive-systems@vem-group.com

VEM Holding GmbH

Pirnaer Landstraße 176

01257 Dresden

Germany

VEM Service

Tel. +49 351 208-3237

Fax +49 351 208-1108

E-mail: service@vem-group.com

© VEM motors GmbH

Realisation: Juniks Marketing GmbH, Dresden

www.juniks-marketing.de

Printed by: Druckerei Thieme Meißen GmbH

Printed in Germany 2/2017 on FSC® Mix

Order number: 8850801 Main catalogue 2017 EN

Nominal price: 20 EUR

